

ERDC/CHL TR-03-7

Coastal and Hydraulics Laboratory



**US Army Corps
of Engineers®**
Engineer Research and
Development Center

Model Study of Monongahela Dam #4 Lock Replacements, Monongahela River, Pittsburgh, Pennsylvania

Hydraulic Model Investigation

Jose E. Sanchez

August 2003

Model Study of Monongahela Dam #4 Lock Replacements, Monongahela River, Pittsburgh, Pennsylvania

Hydraulic Model Investigation

Jose E. Sanchez

*Coastal and Hydraulics Laboratory
U.S. Army Engineer Research and Development Center
3909 Halls Ferry Road
Vicksburg, MS 39180-6199*

Final report

Approved for public release; distribution is unlimited

20030915 037

ABSTRACT: Navigation improvements are being investigated for several existing projects on the Monongahela River. A hydraulic model study was conducted to evaluate filling and emptying system design alternatives and flow conditions in the upper and lower approaches for the lock replacements at Locks and Dam #4. A 1:25-scale model was constructed to determine the range of lock performance for both locks. The proposed filling and emptying system for the locks is an In-Chamber Longitudinal Culvert Filling and Emptying System. The filling time for acceptable chamber performance with the 6.035-m (19.8-ft) lift was 8.3 min. This filling time was achieved with a 3.0-min valve. The emptying time for the same lift was 8.75 min, and it was achieved with a valve time between 1.0 and 2.0 min. Experiments were also performed to measure the surge created in the vicinity of the proposed downstream lock approach during emptying operations. Results showed that the water-surface elevation in the lower approach increased by 0.37 ft and occurred approximately 1.5 to 3.0 min into the emptying cycle.

DISCLAIMER: The contents of this report are not to be used for advertising, publication, or promotional purposes. Citation of trade names does not constitute an official endorsement or approval of the use of such commercial products. All product names and trademarks cited are the property of their respective owners. The findings of this report are not to be construed as an official Department of the Army position unless so designated by other authorized documents.

Contents

Conversion Factors, Non-SI to SI Units of Measurement.....	v
Preface.....	vi
1—Introduction.....	1
Background.....	1
Prototype.....	1
Purpose and Scope.....	3
2—Physical Model.....	4
Description.....	4
Appurtenances and Instrumentation.....	8
Similitude Considerations.....	9
Kinematic similitude.....	9
Dynamic similitude.....	10
Similitude for lock models.....	10
Experimental Procedures.....	11
3—Model Experiments and Results.....	12
Intake Vortex Experiments.....	12
Realignment of Locks.....	13
Pressure Measurements.....	13
Hawser Force Measurements.....	15
Filling Operations.....	16
Type 1 chamber design.....	16
Type 2 chamber design.....	17
Type 3 chamber design.....	17
Alternate Filling Operations.....	17
One clvert.....	17
Two culverts, one valve in each.....	18
Smaller tow.....	18
Emptying Operations.....	19
Downstream Conditions During Emptying Operation.....	19
4—Summary and Conclusions.....	20
Summary.....	20
Conclusions.....	21
References.....	22

List of Figures

Figure 1.	Vicinity map.....	2
Figure 2.	Dry bed view looking downstream at upper approach.....	5
Figure 3.	View of model intake and upstream miter gates	5
Figure 4.	Upstream view of lock chamber and the ILCS	6
Figure 5.	Dry bed view of outlet.....	7
Figure 6.	Dry bed view looking upstream at lower approach.....	7
Figure 7.	Hawser-pull (force links) measuring device.....	9
Figure 8.	Vortex experiment with proposed lock realignment, 1.0-min valve, 6.04-m (19.8-ft) lift	14

Conversion Factors, Non-SI to SI Units of Measurement

Non-SI units of measurement used in the plates in this report can be converted to SI (metric) units as follows:

Multiply	By	To Obtain
feet	0.3048	meters
tons (force)	8.896443	kilonewtons

Preface

The model investigation reported herein was authorized by the Headquarters, U.S. Army Corps of Engineers, at the request of U.S. Army Engineer District, Pittsburgh, in January 2001. The model experiments were performed during the period July 2001 to February 2002 by personnel of the Coastal and Hydraulics Laboratory (CHL), of the U.S. Army Engineer Research and Development Center (ERDC), under the general supervision of Mr. Thomas J. Pokrefke, Acting Assistant Director, CHL, and Mr. Thomas W. Richardson, Director, CHL.

The experimental program was led by Mr. Joe E. Myrick under the supervision of Mr. Jose E. Sanchez, Locks Group, and Mr. Don Wilson, Chief, Navigation Branch, CHL. Model construction was performed by Mrs. Phyllis Burchett and Mrs. Linda Walker of the Carpenter Shop, Department of Public Works (DPW), ERDC, under the general supervision of Mr. Thomas Beard, Chief, Carpenter Shop, DPW. Data acquisition and remote-control equipment were installed and maintained by Messrs. S. Wallace Guy and T. Nicely, Information Technology Laboratory (ITL), ERDC. Data acquisition software was developed by Dr. Barry W. McCleave, ITL. The report was written by Mr. Jose E. Sanchez and reviewed by Dr. John E. Hite, Jr., CHL. Ms. Peggy Van Norman of the Navigation Branch, CHL, assisted in the preparation of the report.

During the course of the model study, Messrs. Walt Leput, Ray Povirk, and Mark Zaitsoff, Pittsburgh District, visited ERDC to observe model operation, review experiment results, and discuss model results.

COL James R. Rowan, EN, was Commander and Executive Director of ERDC. Dr. James R. Houston was Director.

1 Introduction

Background

Many U.S. Army Corps of Engineers Districts are facing the challenge of increasing the lockage capacity at their projects to accommodate increases in tow traffic. Without improvements, the potential for significant traffic delays on the system will occur, resulting in significant economic losses to the Nation. The U.S. Army Engineer District, Pittsburgh, is planning navigation improvements at Monongahela Dam #4 on the Monongahela River. These improvements include construction of two 25.6-m- (84-ft-) wide by 219.46-m- (720-ft-) long locks, replacing the existing 17.07-m- (56-ft-) wide by 219.46-m- (720-ft-) long main chamber and the 17.07-m- (56-ft-) wide by 109.73-m- (360-ft-) long auxiliary chamber.

In the mid 1990s, a number of Corps Districts, Louisville, Huntington, Pittsburgh, and St. Louis, formed an innovative lock design team, pooled their resources, and initiated a study with the U.S. Army Engineer Research and Development Center (ERDC) to find innovative methods to reduce construction and operation costs of navigation structures. This team agreed that large savings in lock wall construction costs could be realized if the lock filling and emptying culverts were placed inside the lock chamber rather than in the lock walls. This filling and emptying system was named the In-Chamber Longitudinal Culvert Filling and Emptying System (ILCS). The navigation improvements planned for the Monongahela #4 project include the use of the ILCS.

Prototype

The existing Locks and Dam #4 project is located on the Monongahela River approximately 66.79 km (41.5 miles) upstream from Pittsburgh, PA (Figure 1). The project consists of a nonnavigable, medium lift, gated dam, an uncontrolled spillway comprised of a 13.11-m- (43-ft-) wide fixed weir, three movable crest tainter gates, and two nonoverflow tainter gates, each 25.6 m (84 ft) in length, and two adjacent, parallel lock chambers. The chambers are located on the right bank of the Monongahela River (looking downstream). The main lock chamber, located on the landward side, has clear dimensions of 17.07 m by 219.46 m (56 ft by 720 ft) and the auxiliary lock chamber 17.07 m by 109.73 m (56 ft by 360 ft).

The nominal lift for the locks is 5.06 m (16.6 ft). Description of lock features and nomenclature used in this report can be found in Engineer Manual (EM) 1110-2-1611, "Layout and Design of Shallow-Draft Waterways," EM 1110-2-

2602, "Planning and Design of Navigation Locks," and EM 1110-2-1604, "Hydraulic Design of Navigation Locks" (U.S. Army Corps of Engineers 1995a, 1995b, 1995c). The existing filling and emptying systems for the locks are the sidewall culvert type (also referred to as a side port filling and emptying system) with intakes located in the upper approach walls and outlets located in the lower approach walls. The existing riverward intake and outlet at each project were designed to draw and discharge, respectively, from each side of the approach wall.

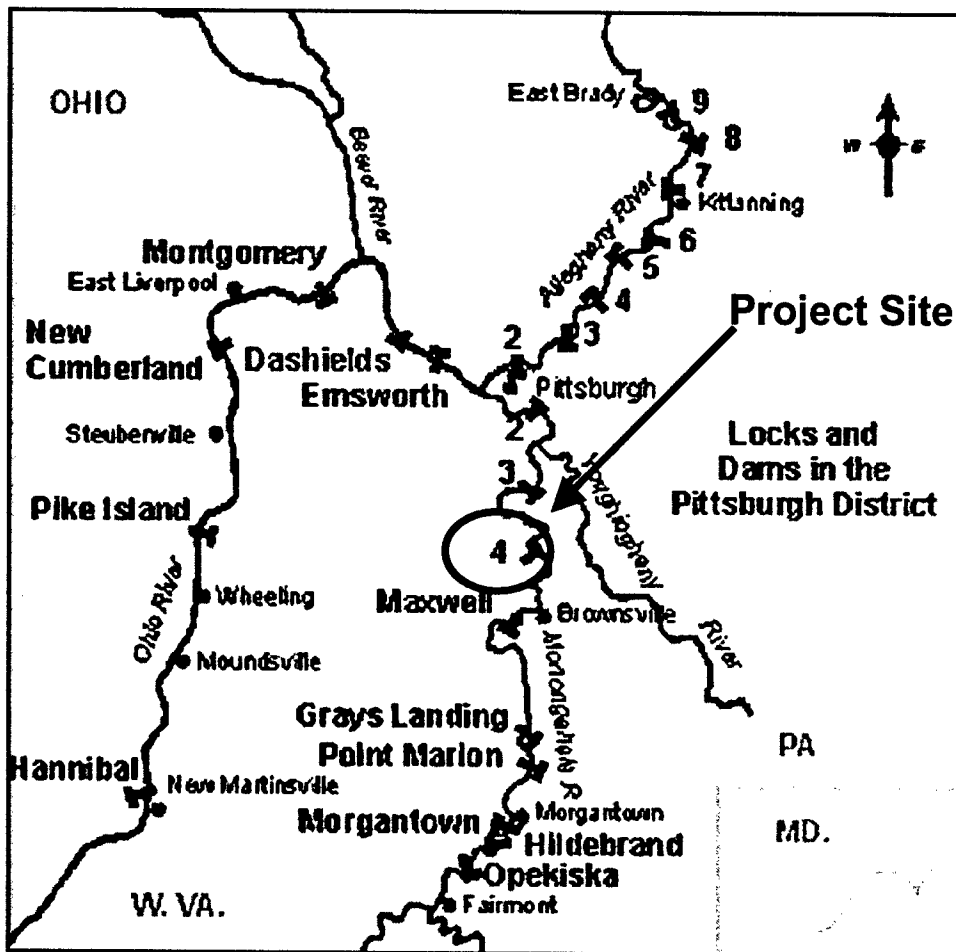

Figure 1. Vicinity map

Improvements to the project to enhance navigation include replacement of the existing locks with longer and wider lock chambers. The new locks will be 240.9 m (790.5 ft) from pintle to pintle and 25.63 m (84.08 ft) wide. The design lift is 6.04 m (19.8 ft), which occurs with a pool elevation of 743.5 and a lower pool elevation of 723.7.¹ The locks will feature a through-the-sill intake, a longitudinal in-chamber filling and emptying system, and an inverted bucket-type discharge outlet.

¹ All elevations (el) cited herein are in feet referred to the National Geodetic Vertical Datum. (To convert feet to meters, multiply by 0.3048.)

Since the proposed filling and emptying systems for both locks are identical, only one lock was reproduced in the laboratory model. Herein, the riverside lock will be the one described, unless otherwise noted.

Purpose and Scope

The purpose of this model study was to evaluate the hydraulic performance and modify the filling and emptying system, if necessary, to provide a design acceptable to the Pittsburgh District and the towing industry for the Monongahela Dam #4 Lock Replacements.

The specific objectives of the study were to determine:

- a. Performance of the through-the-sill intake.
- b. Filling and emptying times for various valve speeds at the design lift of 6.04 m (19.8 ft).
- c. Flow conditions in the lock chamber during filling and emptying operations.
- d. Hawser forces exerted on barges moored in the lock chamber for various valve speeds at the design lift of 6.04 m (19.8 ft).
- e. Pressures in the filling and emptying system.
- f. Overall system performance.

A laboratory model was used to evaluate the performance of the filling and emptying system. Model studies of lock filling and emptying systems designed for barge traffic have targeted maximum hawser forces of 44.48 kN (5 tons) as a design objective. System design and operation for new projects are optimized such that a full tow at design draft produces hawser forces of 44.48 kN (5 tons) or less during lock operations at the design pool conditions. This limiting maximum hawser force guidance is provided in paragraph 8-6 of EM 1110-2-2602, paragraph E-2 of EM 1110-2-1604, and also in the discussion of permissible filling times in paragraph D-15 of EM 1110-2-1604. Davis (1989) summarizes the findings of physical model studies:

In working with models to determine hawser stresses, it must be noted that when a hawser stress of only 44.48 kN (5 tons) is achieved in a model it does not necessarily follow that the hawser stress on the prototype lock will be no greater than the value measured in the model. On a performance basis it has been found that when the model hawser stress is no greater than 44.48 kN (5 tons), the prototype lock will perform very well and no surging or severe turbulence will occur.

2 Physical Model

Description

The 1:25-scale model reproduced approximately 243.84 m (800 ft) of the upstream approach including a portion of the proposed left guide wall and the right guard wall. The intakes, miter gates, and entire filling and emptying system including culverts and valves, outlet, and approximately 243.84 m (800 ft) of the topography in the downstream approach were also reproduced (Figure 2). The intake, miter gate, filling and emptying culverts, and filling and emptying valves were constructed of acrylic plastic. The upper and lower approaches and lock chamber were constructed of plastic-coated plywood.

A model layout is shown in Plate 1, and photographs of the model are provided in Figures 2-6. The filling and emptying system begins with a multiported intake located in the upstream face of the miter gate sill. Each port is 2.28 m (7.5 ft) wide by 3.05 m (10 ft) high at the face of the intake (Plate 2). Figure 3 shows the model intake looking downstream. Each half of the intake transitions to 2.59-m- (8.5-ft-) wide by 2.13-m- (7-ft-) high culverts located under the miter gate sill where the filling valves are located. The culverts continue straight into the lock chamber and into the filling and emptying manifold, which begins at Sta 1+75A (stations increase in the upstream and downstream direction starting at Sta 0+00). The filling and emptying manifold consists of two 3.66-m- (12-ft-) wide by 3.05-m- (10-ft-) high culverts with 12 pairs of ports located in both the upstream and downstream portions of the lock chamber as shown in Plates 3 and 4. The upstream ports contain additional port extensions to direct the filling jets normal to the culverts. The ILCS is shown in Figure 4. Downstream from the filling and emptying manifold, the culverts turn to the left (riverside) into the lock wall where the emptying valves and bulkheads are located (Plate 5). The discharge outlet consists of a flip bucket with a divider wall that partially separates the discharge flow from the locks. Figure 5 shows the inverted bucket-type discharge (only the emptying culverts of the riverside lock are shown).

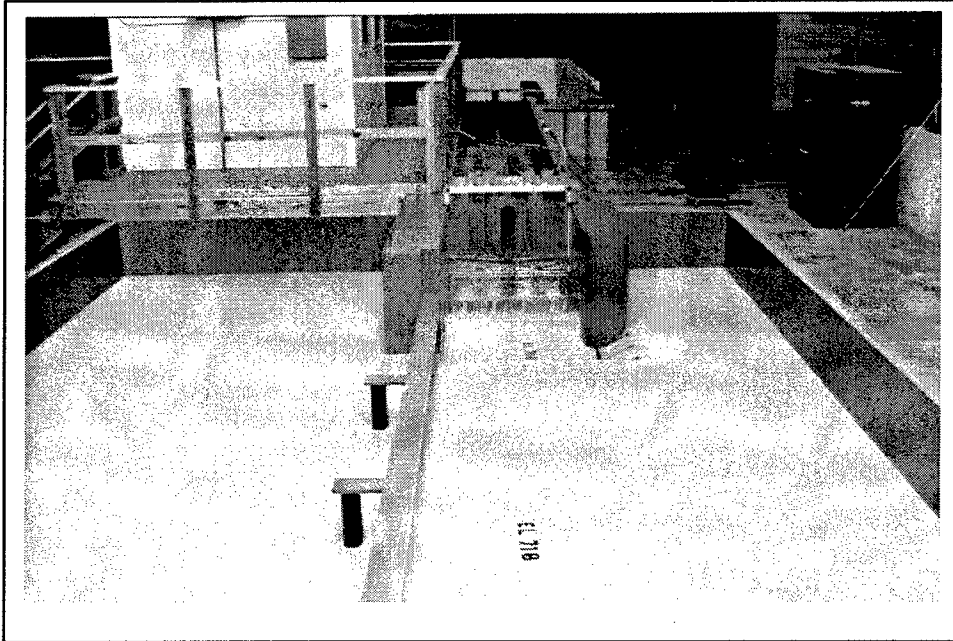

Figure 2. Dry bed view looking downstream at upper approach

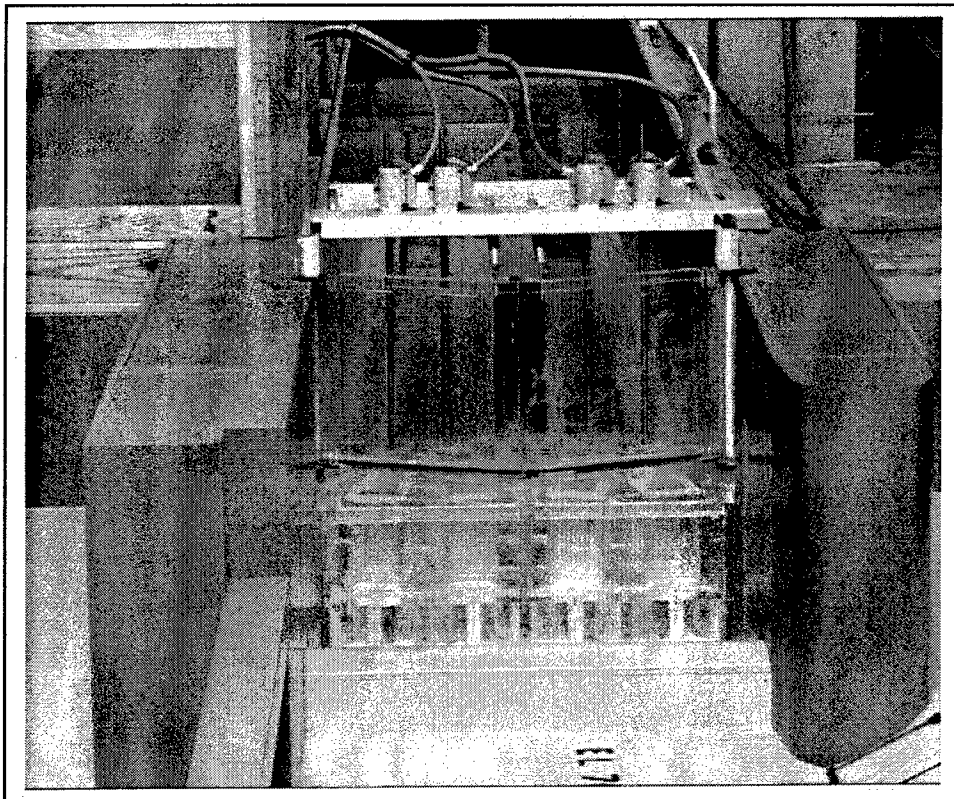

Figure 3. View of model intake and upstream miter gates

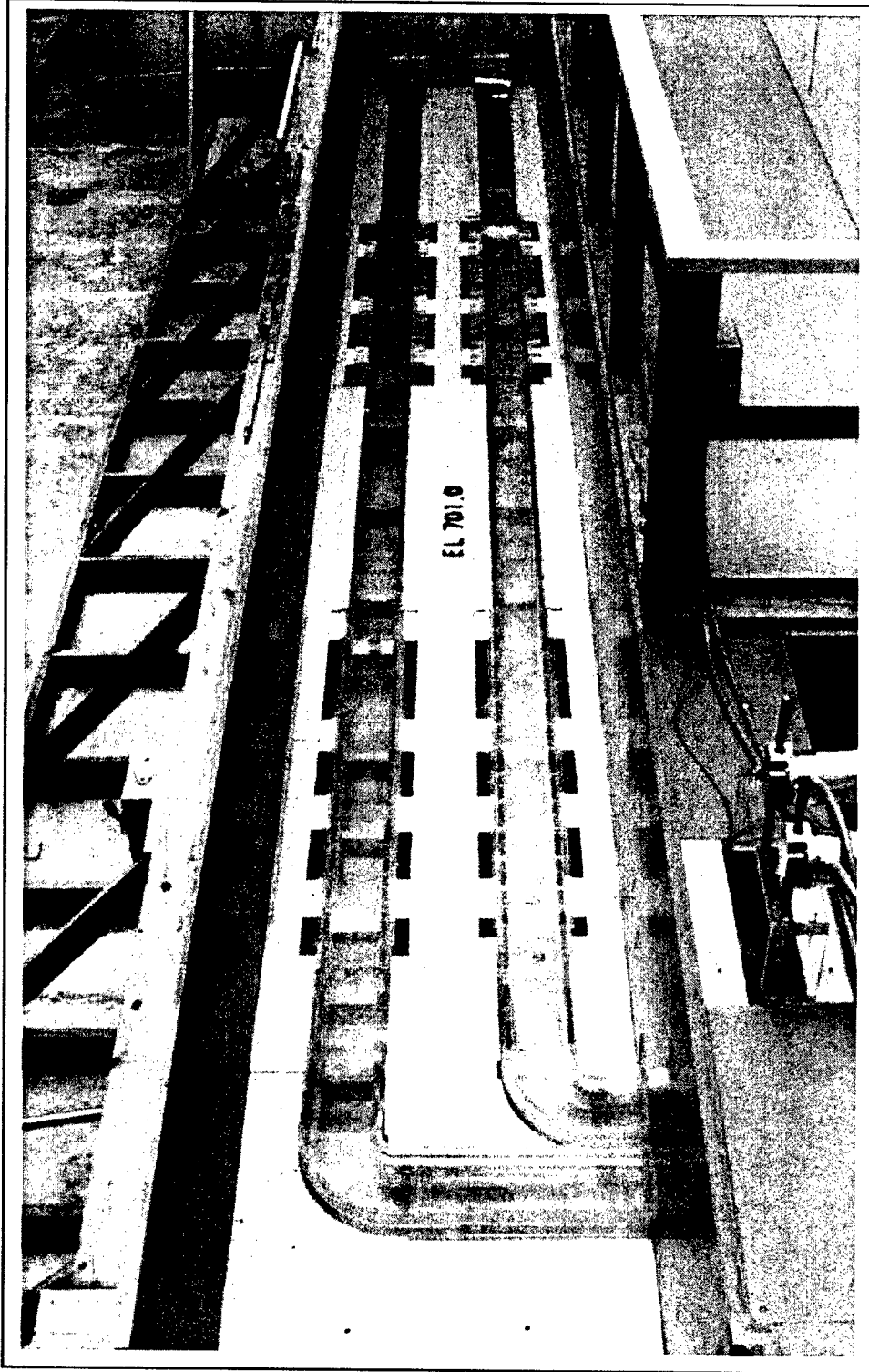

Figure 4. Upstream view of lock chamber and the ILCS

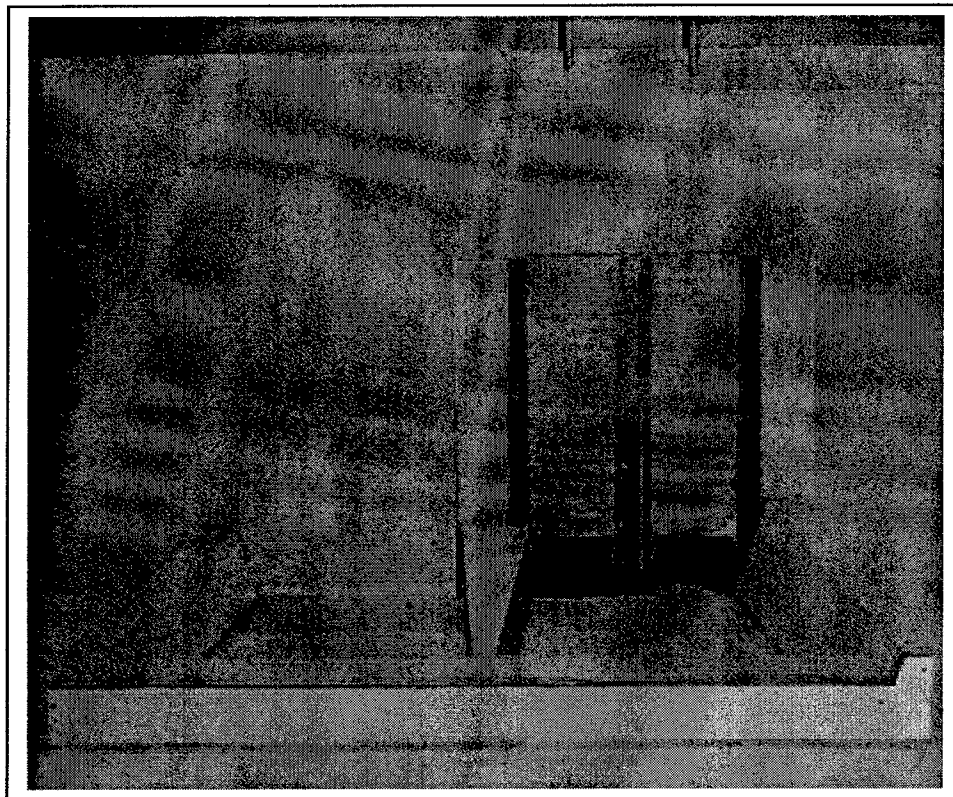

Figure 5. Dry bed view of outlet

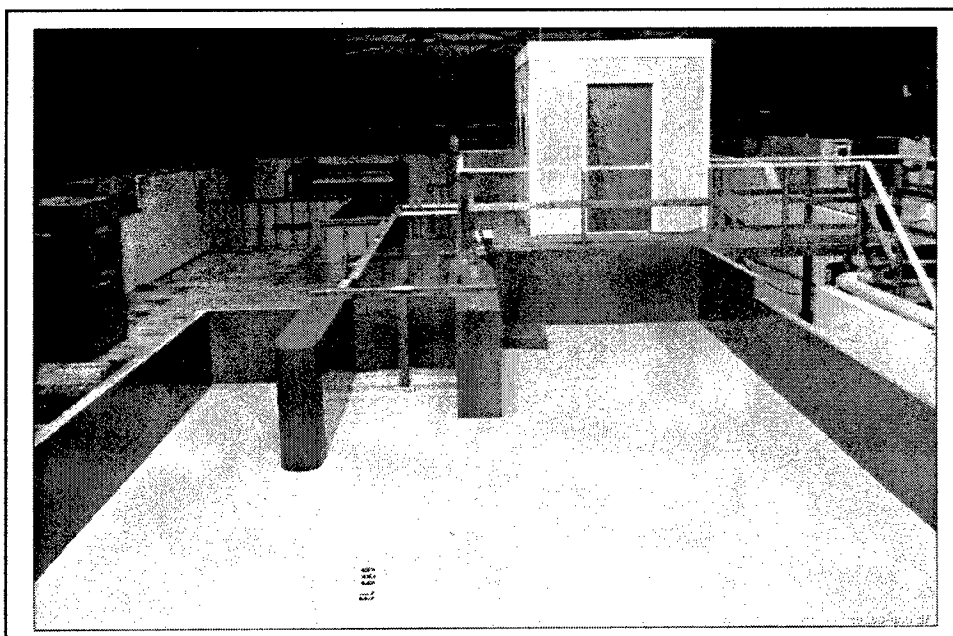

Figure 6. Dry bed view looking upstream at lower approach

Appurtenances and Instrumentation

Water was supplied to the model through a circulating system. The upper and lower pools were maintained at near constant elevations during the filling and emptying operations using constant head skimming weirs in the model headbay and tailbay. During a typical filling operation, excess flow was allowed to drain over the weirs at the beginning of the fill operation, and minimal flow over the weir was maintained at the peak discharge thereby minimizing the drawdown in the upper reservoir. The opposite of this operation was performed during lock emptying. Upper and lower pool elevations were set to the desired level by adjusting the skimming weirs and reading piezometers placed in calm areas of the upper and lower pools. Water-surface elevations inside the chamber were determined from electronic pressure cells located in the middle and on each end of the lock chamber. Dye and confetti were used to study subsurface and surface current directions.

An automated data acquisition and control program, Lock Control, written by Dr. Barry McCleave of the ERDC Information Technology Laboratory was used to control valve operations and collect pressure and strain gauge data. Up to 19 data channels were used, 12 for control of the filling and emptying valves, 4 for pressure data, and 3 for collecting strain gauge information. The data were usually collected at a sampling rate of 50 Hz. Some of the hawser force and lock filling and emptying data were collected at 10 Hz. These data were then processed using a computer program written by Dr. Richard Stockstill of the ERDC Coastal and Hydraulics Laboratory. The processed data were used to determine lock filling and emptying times, longitudinal and transverse hawser forces, and pressures downstream from the filling and emptying valves.

A hawser-pull (force links) device used for measuring the longitudinal and transverse forces acting on a tow in the lock chamber during filling and emptying operations is shown in Figure 7.

Three such devices were used: one measured longitudinal forces and the other two measured transverse forces on the downstream and upstream ends of the tow, respectively. Due to the lock chamber dimensions, a new measuring device was specifically designed for this laboratory model to measure longitudinal forces. These links were machined from aluminum and had SR-4 strain gauges cemented to the inner and outer edges. When the device was mounted on the tow, one end of the link was pin-connected to the tow while the other end was engaged to a fixed vertical rod. While connected to the tow, the link was free to move up and down with changes in the water surface in the lock. Any horizontal motion of the tow caused the links to deform and vary the signal, which was recorded with a personal computer using an analog-to-digital converter. The links were calibrated by inducing deflection with known weights. Instantaneous pressure and strain gauge data were recorded digitally with a personal computer.

Pressures throughout the systems were measured with piezometers (open-air manometers).

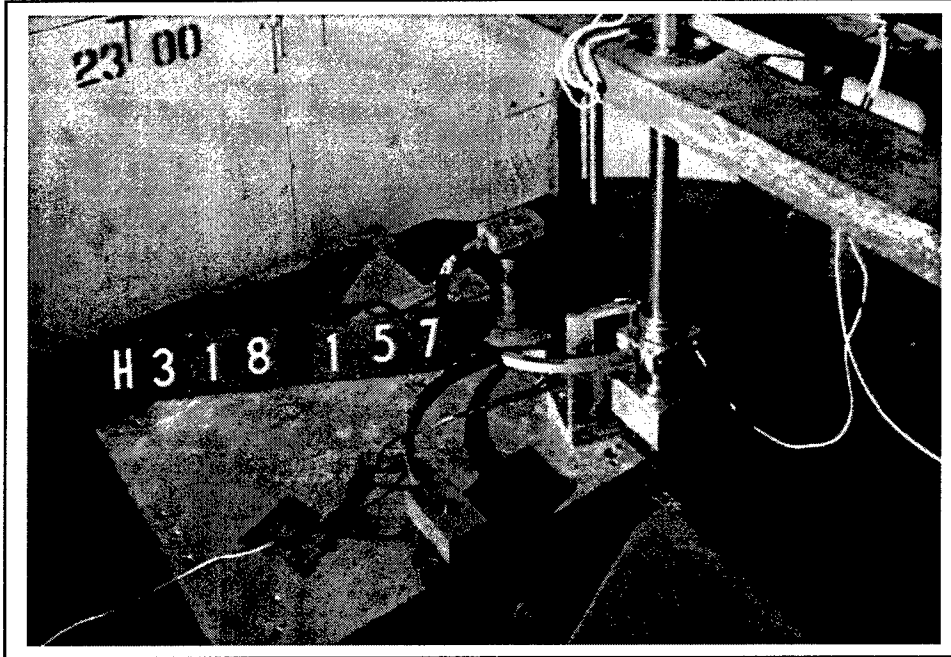

Figure 7. Hawser-pull (force links) measuring device

Similitude Considerations

Kinematic similitude

Kinematic similarity is an appropriate method of modeling free-surface flows in which the viscous stresses are negligible. Kinematic similitude requires that the ratio of inertial forces ($\rho V^2 L^2$) to gravitational forces ($\rho g L^3$) in the model are equal to those of the prototype. Here, ρ is the fluid density, V is the fluid velocity, L is a characteristic length, and g is the acceleration due to gravity.

This ratio is generally expressed as the Froude number, N_F , where L is usually taken as the flow depth in open-channel flow:

$$N_F = \frac{V}{\sqrt{gL}} \quad (1)$$

The Froude number can be viewed in terms of the flow characteristics. Because a surface disturbance travels at celerity of a gravity wave, $(gh)^{1/2}$, where h is the flow depth, it is seen that the Froude number describes the ratio of advection speed to the gravity wave celerity. Evaluation of the lock chamber performance primarily concerns modeling of hawser forces on moored barges during filling and emptying operations. These hawser forces are generated primarily by slopes in the lock chamber water surface. The tow's bow-to-stern water-surface differentials are the result of long period seiches or oscillations in the lock chamber. Seiching is gravity waves traveling in the longitudinal direction from the upper miter gates to the lower miter gates. Equating Froude numbers in the model and prototype is an appropriate means of modeling the lock chamber.

Dynamic similitude

Modeling of forces is a significant purpose of the laboratory investigation. Appropriate scaling of viscous forces requires the model be dynamically similar to the prototype. Dynamic similarity is accomplished when the ratios of the inertia forces to viscous forces (μVL) of the model and prototype are equal. Here, μ is the fluid viscosity. This ratio of inertia to viscous forces is usually expressed as the Reynolds number where ν is the kinematic viscosity of the fluid ($\nu = \mu/\rho$) and the pipe diameter is usually chosen as the characteristic length, L , in pressure flow analysis.

$$N_R = \frac{VL}{\nu} \quad (2)$$

Similitude for lock models

Complete similitude in a laboratory model is attained when geometric, kinematic, and dynamic similitudes are satisfied. Physical models of hydraulic structures with both internal flow (pressure flow) and external flow (free surface) typically are scaled using kinematic (Froudian) similitude at a large enough scale so that the viscous effects in the scaled model can be neglected. More than 50 model and 10 prototype studies of lock filling and emptying systems have been investigated (Pickett and Neilson 1988). The majority of these physical model studies used a scale of 1:25 (model:prototype). Lock model velocities scaled using kinematic similitude (model Froude number equal to prototype Froude number) in a 1:25-scale model have maximum Reynolds numbers at peak discharges on the order of 10^5 , yet the corresponding prototype values are on the order of 10^7 .

Boundary friction losses in lock culverts are empirically described using the smooth-pipe curve of the Darcy-Weisbach friction factor where the headloss is expressed as

$$H_f = f \frac{L}{D} \frac{V^2}{2g} \quad (3)$$

where

H_f = headloss due to boundary friction

f = Darcy-Weisbach friction factor

L = culvert length

D = culvert diameter

The Darcy-Weisbach friction factor for turbulent flow in smooth pipes is given in an implicit form (Vennard and Street 1982):

$$\frac{1}{\sqrt{f}} = 2.0 \log \left(N_R \sqrt{f} \right) - 0.8 \quad (4)$$

Because f decreases with increasing N_R , the model is hydraulically “too rough.” The scaled friction losses in the model will be larger than those experienced by the prototype structure. Consequently, the scaled velocities (and discharges) in the model will be less and the scaled pressures within the culverts will be higher than those of the prototype. Low pressures were not a major concern with this design; however, the lower discharges would in turn result in longer filling and emptying times in the model than the prototype will experience. Prototype filling and emptying times for similar designs will be less than those measured in a 1:25-scale lock model.

Modeling of lock filling and emptying systems is not entirely quantitative. The system is composed of pressure flow conduits and open-channel components. Further complicating matters, the flow is unsteady. Discharges (therefore N_F and N_R) vary from no flow at the beginning of an operation to peak flows within a few minutes and then return to no flow at the end of the cycle. Fortunately though, engineers now have about 50 years of experience in conducting large-scale models and subsequently studying the corresponding prototype performance. This study used a 1:25-scale Froudian model in which the viscous differences were small and could be estimated based on previously reported model-to-prototype comparisons. Setting the model and prototype Froude numbers equal results in the following relations between the dimensions and hydraulic quantities:

Characteristic	Dimension ¹	Scale Relation Model:Prototype
Length	$L_r = L$	1:25
Pressure	$P_r = L_r$	1:25
Area	$A_r = L_r^2$	1:625
Velocity	$V_r = L_r^{1/2}$	1:5
Discharge	$Q_r = L_r^{5/2}$	1:3, 125
Time	$T_r = L_r^{1/2}$	1:5
Force	$F_r = L_r^3$	1:15,625

¹ Dimensions are in terms of length.

These relations were used to transfer model data to prototype equivalents and vice versa.

Experimental Procedures

Evaluation of the various elements of the lock system was based on data obtained during typical filling and emptying operations. Performance was based primarily on hawser forces on tows in lockage, roughness of the water surface, pressures, and time required for filling and emptying.

3 Model Experiments and Results

Intake Vortex Experiments

The initial model experiments were performed to determine the lock approach flow conditions and the performance of the intake. Intakes placed in the miter gate sill are more prone to vortex formation than intakes located upstream and outside the lock approach walls (Hite 1999). The performance of the intakes was based on the observation of approach flows and classification of the maximum strength vortex that formed in the lock approach during the filling cycle. The Alden Research Laboratory Vortex Classification (Padmanabhan and Hecker 1984) shown in Plate 6 was used to document the strength of observed vortices. The strength of a vortex may range from a type 1, which is a noticeable surface swirl, to a type 6, which is a full aircore to the intake. Vortices stronger than a type 3 are not desirable in a Froude model of this scale. The type 3 vortex has a visual dye core from the water surface to the intake, which could be observed if one were able to inject dye into a vortex of this strength. Dye was not injected into the vortex during these model experiments since the injection process may affect the strength of the vortex. Type 2 and type 4 vortices are fairly well defined, and any vortex with a strength in between is classified as a type 3 vortex.

Generally, model experiments were repeated to fully evaluate vortex formation. A 20-min stilling period was allowed before each filling cycle was initiated or repeated to let false or residual currents dissipate in the flume; however, model results were not always repeatable even with this experimental procedure. It is not uncommon in unsteady flow experiments documenting vortex strengths to observe different results since initial conditions will not always be exactly the same. A minimum of five filling cycles was used to determine the performance of each headwater and tailwater combination, and respective valve speeds, but additional experiments were often conducted to further evaluate or verify the performance of a specific condition.

The design upper and lower pool conditions (el 743.5 and el 723.7, respectively) were used to conduct all of the vortex experiments. A 1.0-, 2.0-, and 3.0-min filling valve time operation was utilized to evaluate the performance of the intake. The strongest vortices were seen with a 1.0-min valve time.

These tests were performed for both lock approaches. The landside lock approach differs from the riverside lock in that it has a fixed guide wall on the right side (looking downstream) and the shared guard wall on the left. Plates 7 and 8 show that the vortex changed locations. This is due to the location of the guard wall that separates both locks.

In the landside lock approach, the vortex formed in front of the right side of the intake, approximately 9.14 m (30 ft) upstream of the face of the miter sill. During the filling cycle, flow approaches from two directions, stream wise and around the guard wall nose. The flow that corners around the guard wall's nose interacts with the stream wise flow and creates a shedding of vortices that establishes a circulation pattern in front of the intakes. This pattern changes direction depending on the guard wall's location (right for the landside lock and left for the riverside lock). A type 2 vortex was the maximum observed, and it lasted approximately 10 sec (model time). The area where the vortex formed was consistent in all of the experiments.

Realignment of Locks

Additional experiments were conducted to evaluate the performance of the filling system with proposed modifications to the locks. Changes to the laboratory model were made to include a proposed realignment of the locks (Plate 9). The landside lock was moved 215 ft upstream. This modification aligns both locks and their respective upstream and downstream pintles so that they will be located at the same station (US Sta 3+91A and DS Sta 3+99.5B).

The strongest vortices were observed with a 1.0-min valve time. Experiments showed that a type 3 vortex was the maximum observed, and it lasted approximately 15 sec (model time) (Figure 8). The area where the vortex formed was consistent with the previous experiments, except that it changed to the left side of the intake (looking downstream). It should be noted that after the realignment of the locks, the water-surface roughness was increased. In rare instances (one out of eight experiments), utilizing a 1.0-min valve operation, a vortex stronger than a type 3 was formed.

Pressure Measurements

The pressures occurring in the filling and emptying system during steady flow were measured at various locations using piezometers located as shown in Plate 10. The measurements were used to quantify loss coefficients for various components of the system. Energy loss, $H_{L,i}$, through each component is expressed as

$$H_{L,i} = K_i \frac{V^2}{2g} \quad (5)$$

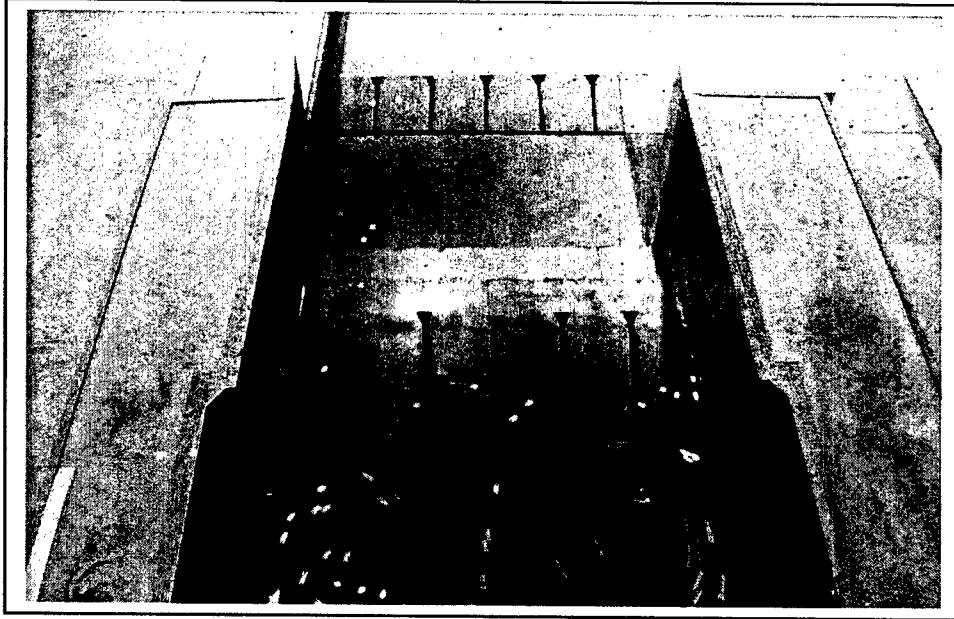

Figure 8. Vortex experiment with proposed lock realignment, 1.0-min valve, 6.04-m (19.8-ft) lift

where

K_i = loss coefficient for component i

V = culvert velocity which is one-half of the total discharge divided by a culvert area at the filling valve of 2.59 m (8.5 ft) by 2.13 m (7 ft)

The total head loss, H_L , through the system is

$$H_L = \sum H_{L_i} = \sum K_i \frac{V^2}{2g} \quad (6)$$

The lock coefficient, C_L , is defined as

$$C_L = \frac{V}{\sqrt{2gH_L}} \quad (7)$$

Equating H_L in each expression shows the relation between the lock coefficient and loss coefficient.

$$K = C_L^{-2} \quad \text{or} \quad C_L = K^{-0.5} \quad (8)$$

where K is the sum of each K_i .

The total energy loss coefficient for the filling system, K , was determined to be 2.2. Distribution of this sum by lock filling components is illustrated in the tabulation below. The corresponding overall lock coefficient, C_L , for the filling system was determined to be 0.67.

Component	Loss Coefficient, K_i
Intake	0.40
Upstream culvert, valve, and transitions	0.31
Upstream culvert	0.28
Manifold	1.25

An equation typically used by the Corps to compute the overall lock coefficient is:

$$C_L = \frac{2A_L \sqrt{H+d} - \sqrt{d}}{A_c (T - kt_v) \sqrt{2g}} \quad (9)$$

where

A_L = area of lock chamber, ft²

H = initial head, ft

d = over travel, ft

A_c = area of culverts, ft²

T = filling time, sec

k = a constant

t_v = valve opening time, sec

g = acceleration due to gravity, ft/sec²

For more information on the development of this equation, refer to Davis (1989). The term $T - kt_v$ is the lock filling and emptying time for the hypothetical case of instantaneous valve operation and is determined directly from the curves presented in Plate 11. Computed coefficient from this equation is $C_L = 0.72$ for filling and $C_L = 0.62$ for emptying with a lift of 6.04 m (19.8 ft). The lock coefficient computed is slightly different than the one determined from the steady-state pressure measurements.

Hawser Force Measurements

Experiments were conducted next to determine the performance of the filling system with an upper pool el 743.5 and a lower pool el 723.7. These upper pool and lower pool conditions represented the 6.04-m (19.8-ft) lift. Experiments were conducted to measure hawser forces for a standard width 7.92-m (26-ft) jumbo length 59.49-m (195-ft) STUMBO barge arrangement secured inside the

lock chamber. The barge configuration measured 219.46 m (720 ft) long and 23.77 m (78 ft) wide with a 7.74-m (9-ft) draft (Plate 12).

As discussed previously, a hawser-pull (force links) device was used for measuring the longitudinal and transverse forces on a tow in the lock chamber during the filling and emptying operations (Figure 7). Hawser force measurements were conducted with 1.0-, 2.0-, and 3.0-min linear valve operations. The valve schedule utilized for the experiments is shown in Plate 13. Consideration was also given to the use of a sagged valve operation (Plate 14), but results showed that there was no apparent reduction in the hawser forces and the filling time was increased. This prompted the continued testing of only the linear valve schedule.

Filling Operations

Type 1 chamber design

The first set of experiments was conducted to evaluate the Type 1 (original) lock chamber design during filling and emptying operations. Hereafter, the Type 1 chamber design will be referred to as the original chamber design. This design did not include base lock wall encroachments (Plate 4).

Experiments were first performed with a 1-min valve operation. The average maximum longitudinal hawser forces were considerably higher than desired. Time-histories of the hawser forces and the filling curve are shown in Plate 15 for the Type 1 design and 1.0-min valve operation. The largest hawser force experienced during the filling operation was in the upstream direction. The through-the-sill intake design located the valves in a service chamber under the upstream miter sill (Plate 2). This design included a ledge at el 728 that extends 9.39 m (30.8 ft) downstream of the miter gates. As the water surface in the chamber rises during filling, the area being filled changes. At the beginning of the filling cycle, the area being filled is smaller and once the water surface rises over the ledge, the chamber area being filled is larger. This change makes the water move upstream and with it the barge. The maximum upstream longitudinal hawser force was 100.53 kN (11.3 tons) and occurred between 0 and 1 min into the filling cycle. The maximum upstream transverse hawser forces measured during filling with the 1.0-min valve were -43.59 kN (-4.9 tons) to the left side of the chamber and 24.91 kN (2.8 tons) to the right side of the chamber. The maximum downstream transverse hawser forces measured with the same valve operation were -43.59 kN (-4.9 tons) to the left side of the chamber and 24.02 kN (2.7 tons) to the right side of the chamber. The transverse hawser forces did not exceed the 44.48-kN (5-ton) limit with the 6.04-m (19.8-ft) lift and 1.0-min filling valve. The lock filled in 7.6 min with the 1.0-min filling valve operation.

To determine the filling time required to maintain 44.48-kN (5-ton) hawser forces or less with a 6.04-m (19.8-ft) lift, experiments were conducted with filling valve operations of 1, 2, and 3 min. The results from these experiments are shown in Plate 16. The filling times and maximum hawser forces shown are an average value computed from several experiments. Experiments were repeated to

ensure consistency. The filling time required to maintain hawser forces of 44.48 kN (5 tons) or less was 8.3 min. This filling time resulted from a valve operation slightly over 2.0 min.

Type 2 chamber design

Structural engineering developed another chamber design that included a base wall encroachment. The Type 2 chamber design included this encroachment of both lock walls (Plate 17). The thickness at the base of the chamber wall was increased to address concerns of middle wall stability. Experiments demonstrated that there was no significant difference in the hawser force measurements between the original design and the Type 2 chamber design, as shown by comparing the time-histories in Plates 18 and 19 with the 3-min normal valve and design lift.

Type 3 chamber design

Another design tested was the Type 3 chamber design (Plate 20). This design included only one base wall encroachment, which would reduce the cost of construction when compared to the Type 2. The encroachment was located in the middle wall (landside wall for riverside lock, and riverside wall for landside lock). Experiments demonstrated that there was no significant difference between the original design and the Type 3 chamber design, as shown by comparing the time-histories in Plates 18 and 21.

Alternate Filling Operations

One culvert

Experiments were conducted next to determine the performance of the filling system using only one culvert to fill the chamber. The landside (right side) culvert was used during these experiments. Plate 22 shows typical time-histories with a 6.04-m (19.8-ft) lift and 2-min filling valves.

The maximum upstream longitudinal hawser force was 21.35 kN (2.4 tons) and occurred between 0 and 1 min into the filling cycle. The maximum upstream transverse hawser forces measured during filling with the 2.0-min valve were -2.67 kN (-0.3 tons) to the left side of the chamber and 50.71 kN (5.7 tons) to the right side of the chamber. The maximum downstream transverse hawser forces measured with the same valve operation were -2.67 kN (-0.3 tons) to the left side of the chamber and 43.59 kN (4.9 tons) to the right side of the chamber. The transverse hawser forces exceeded the 44.48-kN (5-ton) limit with the 6.04-m (19.8-ft) lift and 2.0-min filling valve. During single culvert operations with the ILCS, the highest transverse hawser forces occurred on the same side as the culvert in operation.

To determine the filling time required to maintain 44.48-kN (5-ton) hawser forces or less with a 6.04-m (19.8-ft) lift, experiments were conducted with

filling valve operations of 2.0, 3.0, and 4.0 min. The results from these experiments are shown in Plate 23. The filling time required to maintain hawser forces of 44.48 kN (5 tons) or less was 17.7 min. This filling time resulted from a 2.0-min valve operation.

Two culverts, one valve in each

Experiments were also conducted to determine the performance of the filling system utilizing only one valve in each of the culverts. The outside valves (valves located closest to the lock walls) were operated with a linear valve schedule to evaluate chamber conditions.

Plate 24 shows a typical time-history with a 6.04-m (19.8-ft) lift and a 1.0-min filling valve.

The maximum upstream longitudinal hawser force was 41.81 kN (4.7 tons) and occurred between 1 and 2 min into the filling cycle. The maximum upstream transverse hawser forces measured during filling with the 1.0-min valve were -19.57 kN (-2.2 tons) to the left side of the chamber and 9.79 kN (1.1 tons) to the right side of the chamber. The maximum downstream transverse hawser forces measured with the same valve operation were -20.46 kN (-2.3 tons) to the left side of the chamber and 9.79 kN (1.1 tons) to the right side of the chamber. The transverse hawser forces did not exceed the 44.48-kN (5-ton) limit with the 6.04-m (19.8-ft) lift and 1.0-min filling valve. The average filling time associated with this valve operation was 10.5 min (Plate 25). The average maximum hawser forces are also shown in Plate 25.

Smaller tow

Experiments were also conducted to measure hawser forces for a smaller tow/barge arrangement. The tow and barge configuration measured 106.68 m (350 ft) long and 23.77 m (78 ft) wide with a 2.74-m (9-ft) draft (Plate 26).

Hawser force measurements were conducted with 1.0-, 2.0-, and 3.0-min fill valve operations. Plate 27 shows a typical time-history with a 6.04-m (19.8-ft) lift and a 1.0-min filling valve. The maximum upstream longitudinal hawser force was 70.73 kN (7.9 tons) and occurred between 0 and 1 min into the filling cycle. The maximum upstream transverse hawser forces measured during filling with the 1.0-min valve were -21.35 kN (-2.4 tons) to the left side of the chamber and 19.75 kN (2.2 tons) to the right side of the chamber. The maximum downstream transverse hawser forces measured with the same valve operation were -35.59 kN (-4.0 tons) to the left side of the chamber and 25.80 kN (2.9 tons) to the right side of the chamber. The transverse hawser forces did not exceed the 44.48-kN (5-ton) limit with the 6.04-m (19.8-ft) lift and 1.0-min filling valve.

To determine the filling time required to maintain 44.48-kN (5-ton) hawser forces or less with a 6.04-m (19.8-ft) lift, experiments were conducted with filling valve operations of 1 and 2 min. The results from these experiments are

shown in Plate 28. The filling time required to maintain hawser forces of 44.48 kN (5 tons) or less was 7.9 min.

Emptying Operations

Hawser force measurements and emptying times were also determined for the 6.04-m (19.8-ft) lift. Plate 29 shows a typical time-history with a 6.04-m (19.8-ft) lift and a 1.0-min emptying valve. Plates 30 and 31 show the average maximum hawser forces measured for the large and small tow/barge arrangements during emptying operations. The hawser force magnitudes were considerably lower for similar valve operations than those measured during the filling cycle. The average maximum longitudinal hawser force measured with the 1.0-min valve was 46.26 kN (5.2 tons) in the downstream direction.

To determine the emptying time required to maintain 44.48-kN (5-ton) hawser forces or less with a 6.04-m (19.8-ft) lift, experiments were conducted with emptying valve operations of 1.0 and 2.0 min. An emptying time of 8.7 min was necessary to maintain hawser forces of 44.48 kN (5 tons) or less with the large tow. An 8.7-min emptying time results with an emptying valve operation between 1.0 and 2.0 min.

In the case of the smaller tow, the hawser forces did not exceed 44.48 kN (5 tons) with the 1.0-min valve operation. The emptying time with a 1.0-min valve was 8.7 min.

Downstream Conditions During Emptying Operation

After meeting with personnel from the Pittsburgh District, it was decided that in order to improve the design of the proposed floating guide wall in the downstream approach, it was necessary to have an estimate of the water-surface conditions in the vicinity of the floating structure during a typical emptying operation.

Experiments were conducted to measure the maximum surge height created by the outlet discharge in the vicinity of the guide wall, at the location shown in Plate 32.

Plate 33 shows a typical time-history of the water-surface elevation with a 6.04-m (19.8-ft) lift and a 1.0-min emptying valve operation.

Results show that the water surface increased by 0.11 m (0.37 ft) in the location of the measuring device.

4 Summary and Conclusions

Summary

A 1:25-scale model of the proposed lock replacement project at Monongahela Dam #4 was constructed to evaluate the lock filling and emptying system performance. No modifications to the upstream approach were necessary, for all chamber designs, to reduce the strength of vortices observed during filling operations. The flow conditions in the upper approach were evaluated for the landside and riverside lock. Experiments showed that a type 3 vortex was the maximum strength observed in both lock approaches, and its duration and location were consistent. Small vortices should be expected during the filling operations.

Model experiments with the Type 1 chamber design revealed the performance was acceptable with the 3.0-min valve operation for the filling cycle and between a 1.0- and 2.0-min valve operation for the emptying cycle. The filling and emptying times with these valve operations were 8.3 min and 8.75 min, respectively. Both valve operations resulted in maximum hawser forces less than 44.48 kN (5 tons) for the 6.04-m (19.8-ft) lift. Type 2 and Type 3 chamber designs that included structural modifications at the base of the lock walls were also tested, but no significant changes in performance were observed. No changes were made to the discharge outlet design.

Experiments were also conducted to evaluate the performance of the lock filling system with alternate valve operations. The chamber was filled using only one culvert (landside). The filling time required to maintain hawser forces of 44.48 kN (5 tons) or less was 17.7 min. This filling time resulted from a 3.0-min valve operation. Another set of experiments was conducted using one filling valve in each culvert. The valves that were operated were the ones located closest to the lock walls. Results showed that the average filling time associated with this valve operation was 10.6 min.

The prototype lock chamber will fill faster for similar operating conditions than the model indicates due to the friction differences. The prototype filling time is expected to be up to 10 percent faster than those measured in the model.

The computed lock coefficient determined for the original chamber design during filling operations was 0.72, and emptying, 0.62.

Experiments were performed to measure the surge created in the vicinity of the proposed downstream lock approach during emptying operations. Results

showed that the water-surface elevation in the lower approach increased by 0.11 m (0.37 ft) and occurred approximately 1.5 to 3.0 min into the emptying cycle.

Conclusions

The model investigation revealed that:

- a.* Vortices in the upstream lock approach are acceptable with the original approach design.
- b.* To achieve acceptable hawser forces in the chamber with the design lift, the filling valves should not be opened in less than 3.0 min. The emptying valves could be opened in 2.0 min.
- c.* Original design chamber performance was acceptable if filling times of 8.8 min and emptying times of 9.1 min are feasible.
- d.* To achieve acceptable hawser forces in the chamber with the design lift and only one culvert in operation, the filling valves should not be opened in less than 3.0 min.
- e.* Acceptable chamber performance with one filling valve in each culvert was achieved with a 1.0-min valve operation.

References

- Davis, J. P. (1989). "Hydraulic design of navigation locks," Miscellaneous Paper HL-89-5, U.S. Army Engineer Waterways Experiment Station, Vicksburg, MS.
- Hite, J. E., Jr. (1999). "Model study of Marmet Lock filling and emptying system, Kanawha River, West Virginia," Technical Report CHL-99-8, U.S. Army Engineer Waterways Experiment Station, Vicksburg, MS.
- Padmanabhan, M., and Hecker, G. E. (1984). "Scale effects in pump sump models," *J. Hydr. Div., ASCE*, 110(11), 1540-1556.
- Pickett, E. B., and Neilson, F. M. (1988). "Lock hydraulic system model and prototype study data," Miscellaneous Paper HL-88-1, U.S. Army Engineer Waterways Experiment Station, Vicksburg, MS.
- U.S. Army Corps of Engineers. (1995a). "Hydraulic design of navigation locks," Engineer Manual 1110-2-1604, Washington, DC.
- _____. (1995b). "Layout and design of shallow-draft waterways," Engineer Manual 1110-2-1611, Washington, DC.
- _____. (1995c). "Planning and design of navigation locks," Engineer Manual 1110-2-2602, Washington, DC.
- Vennard, J. K., and Street, R. L. (1982). *Elementary fluid mechanics*. 6th ed., John Wiley and Sons, New York.

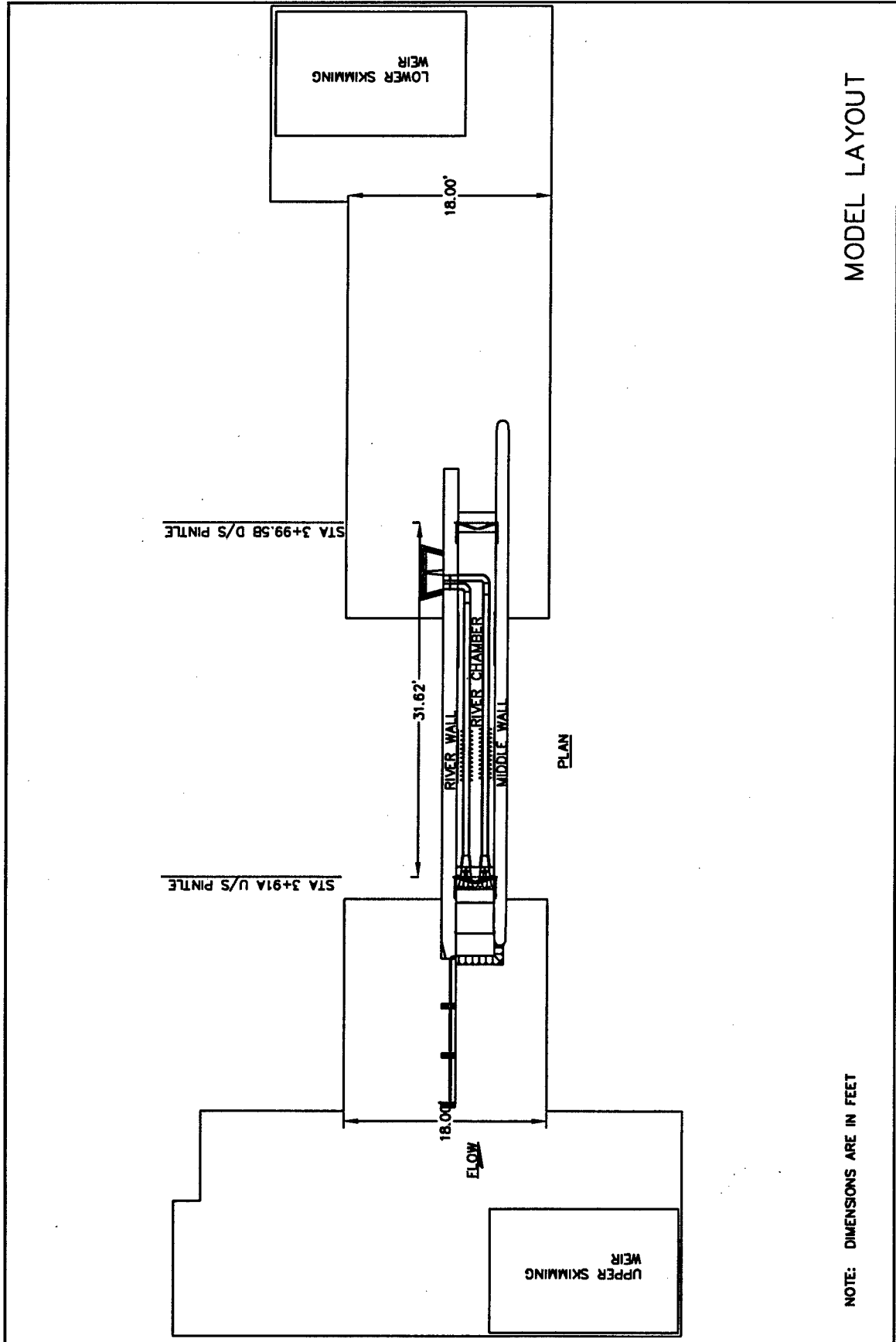

MODEL LAYOUT

NOTE: DIMENSIONS ARE IN FEET

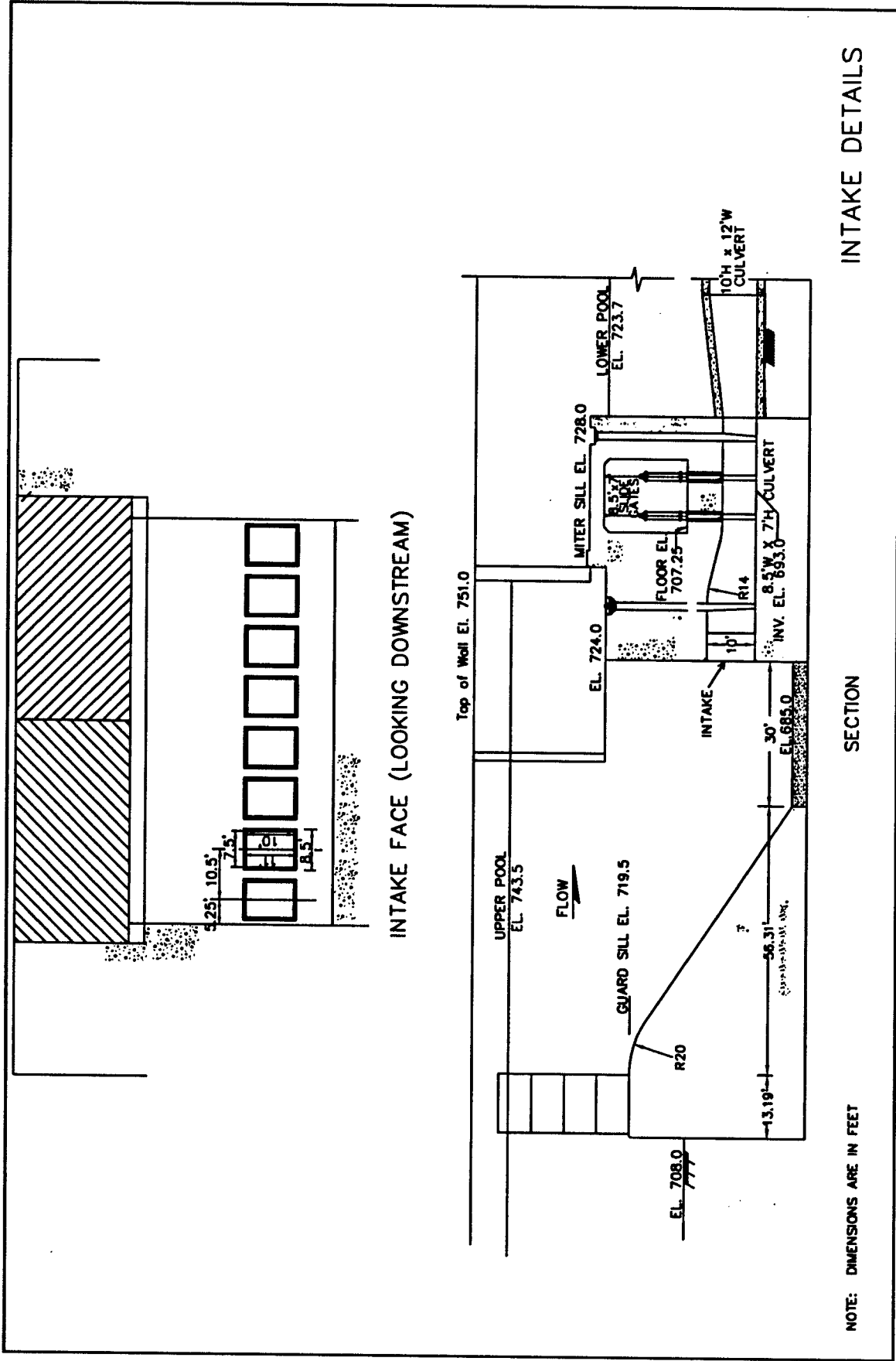

INTAKE DETAILS

SECTION

NOTE: DIMENSIONS ARE IN FEET

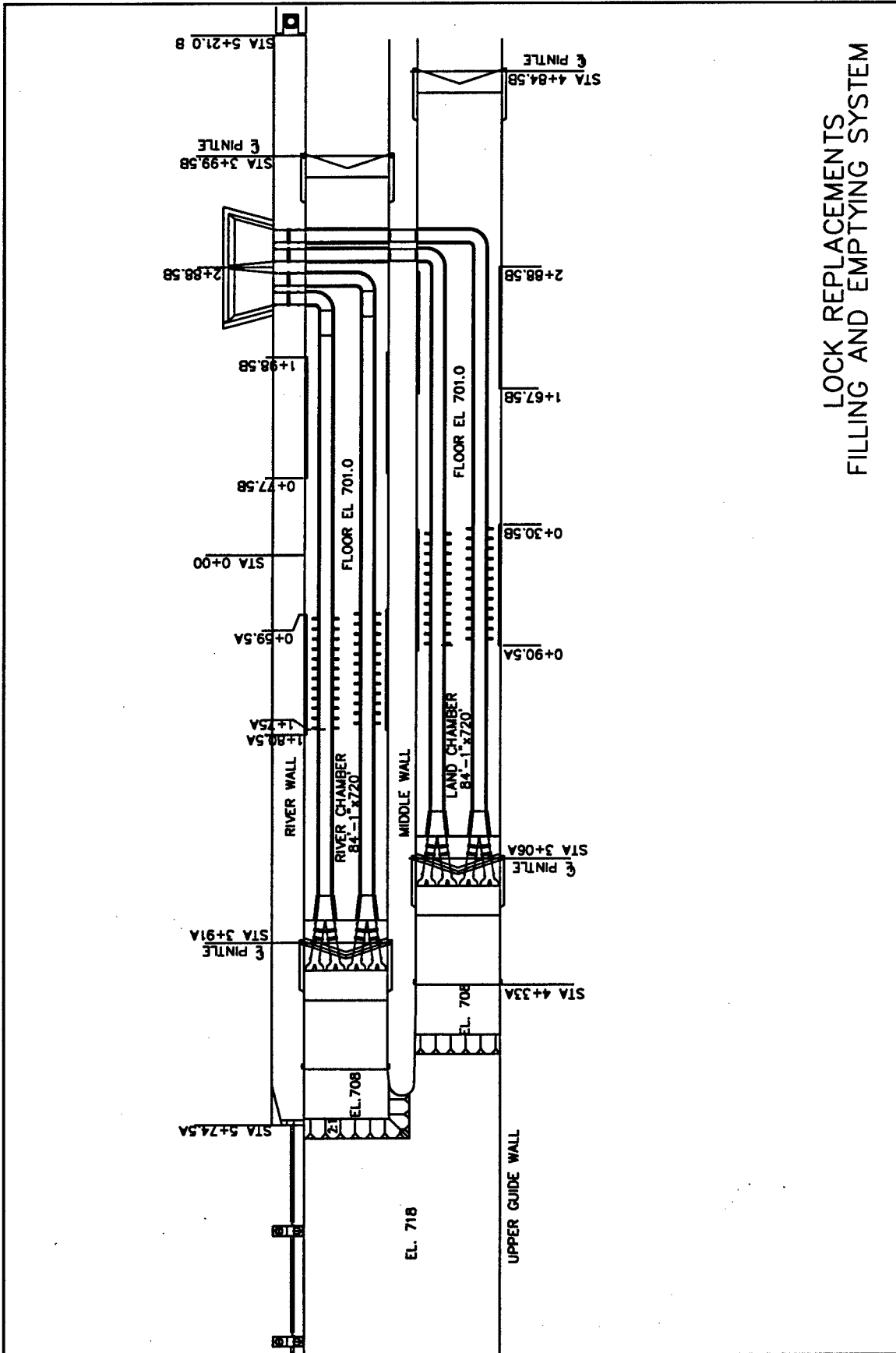

LOCK REPLACEMENTS
FILLING AND EMPTYING SYSTEM

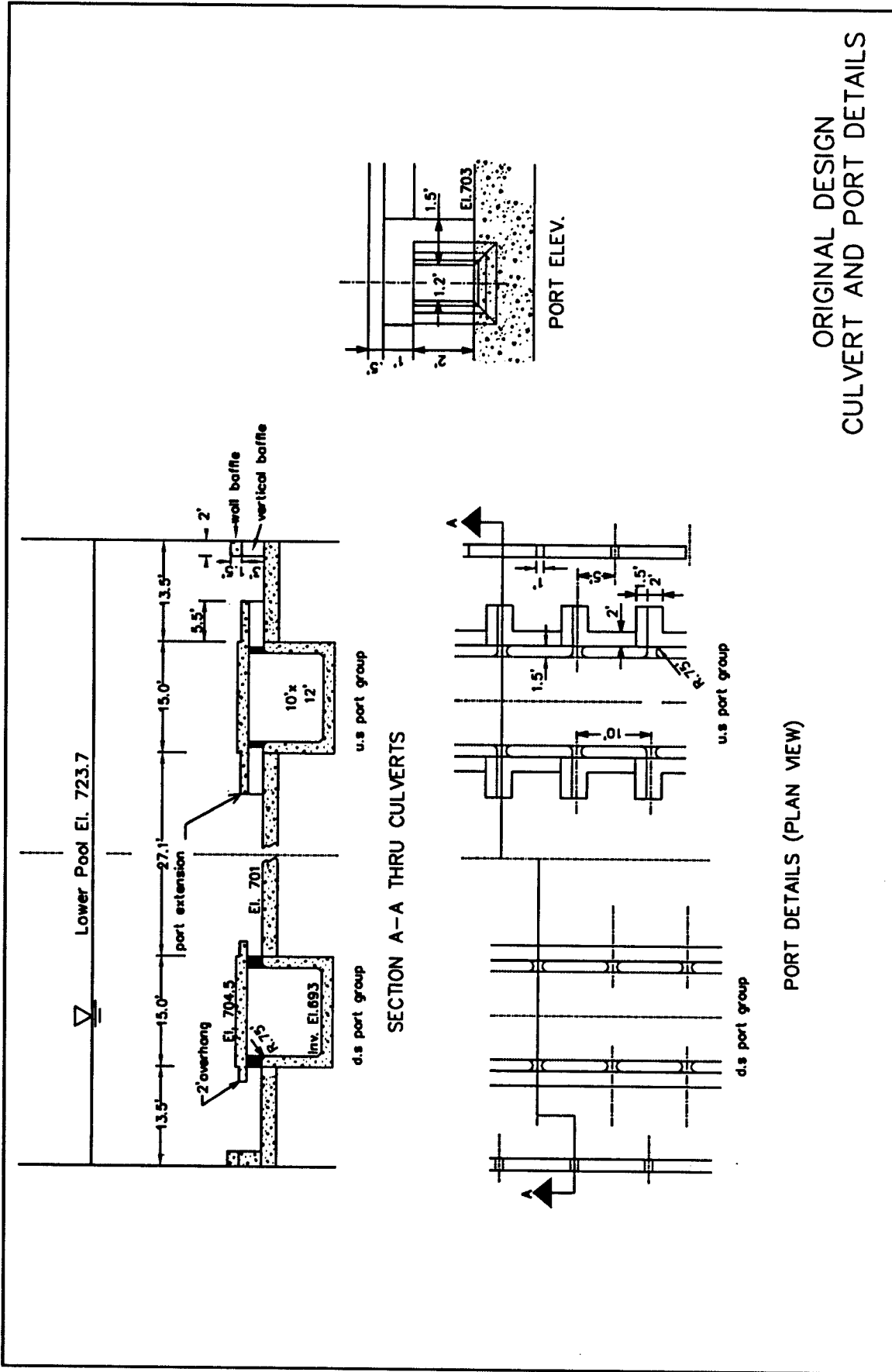

PORT DETAILS (PLAN VIEW)

ORIGINAL DESIGN
CULVERT AND PORT DETAILS

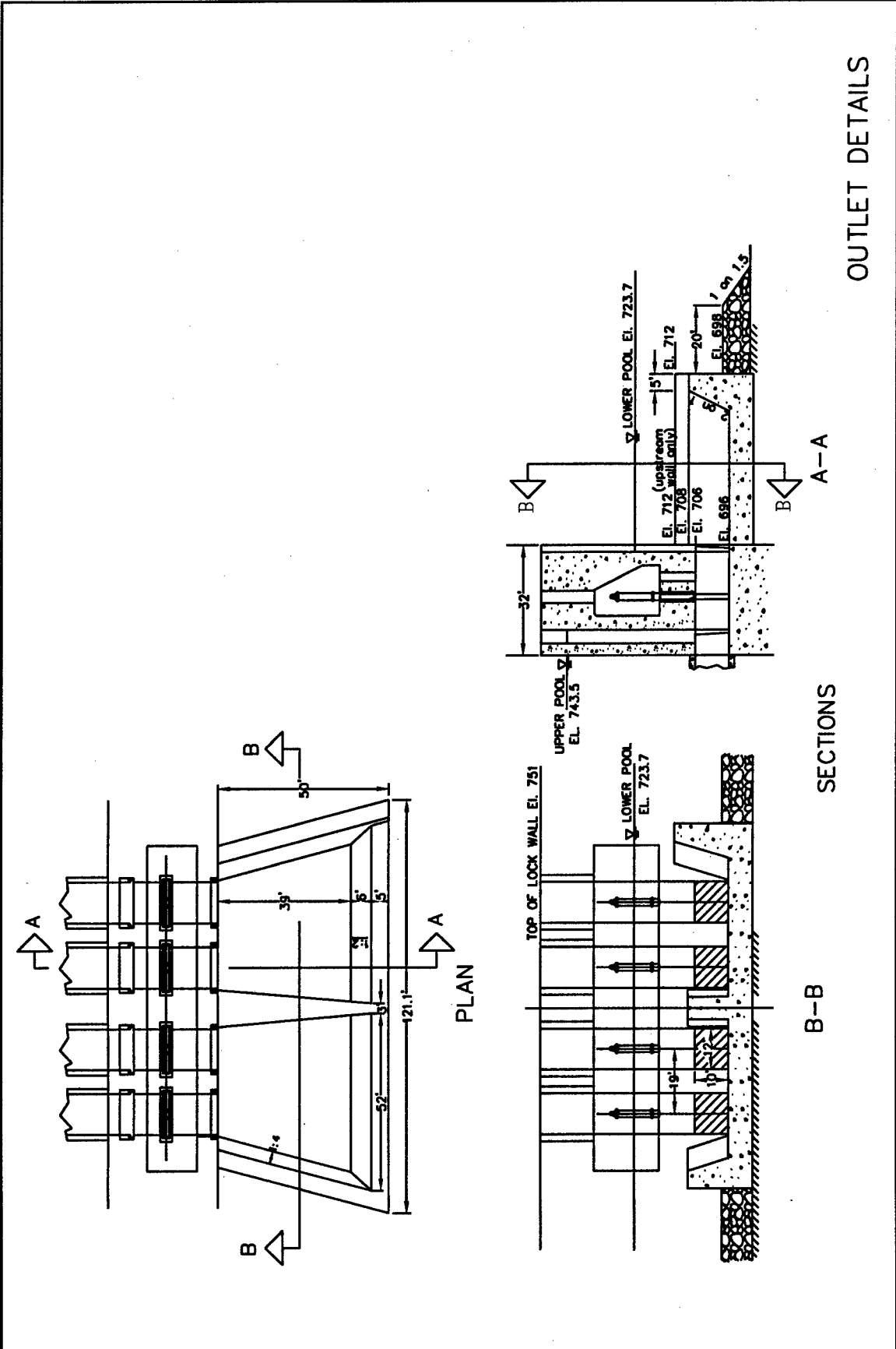

OUTLET DETAILS

SECTIONS

B-B

A-A

VORTEX TYPE

1



COHERENT SURFACE SWIRL

2



SURFACE DIMPLE
COHERENT SWIRL AT SURFACE

3

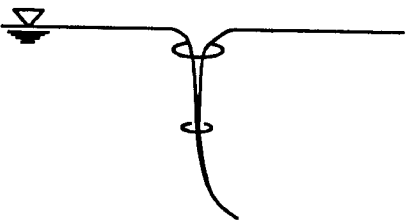

DYE CORE TO INTAKE
COHERENT SWIRL THROUGHOUT
WATER COLUMN

4

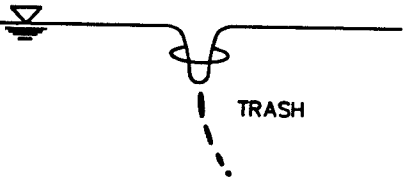

VORTEX PULLING FLOATING
TRASH, BUT NOT AIR

5

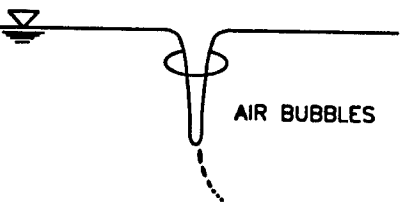

VORTEX PULLING AIR
BUBBLES TO INTAKE

6

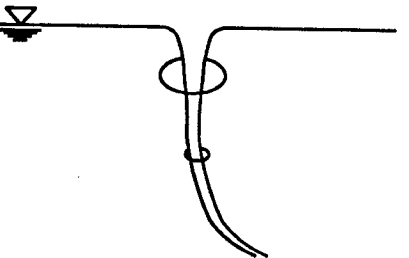

FULL AIR CORE
TO INTAKE

SOURCE: PADMANABHAN AND HECKER (1984)

ALDEN RESEARCH LAB
VORTEX TYPE CLASSIFICATION

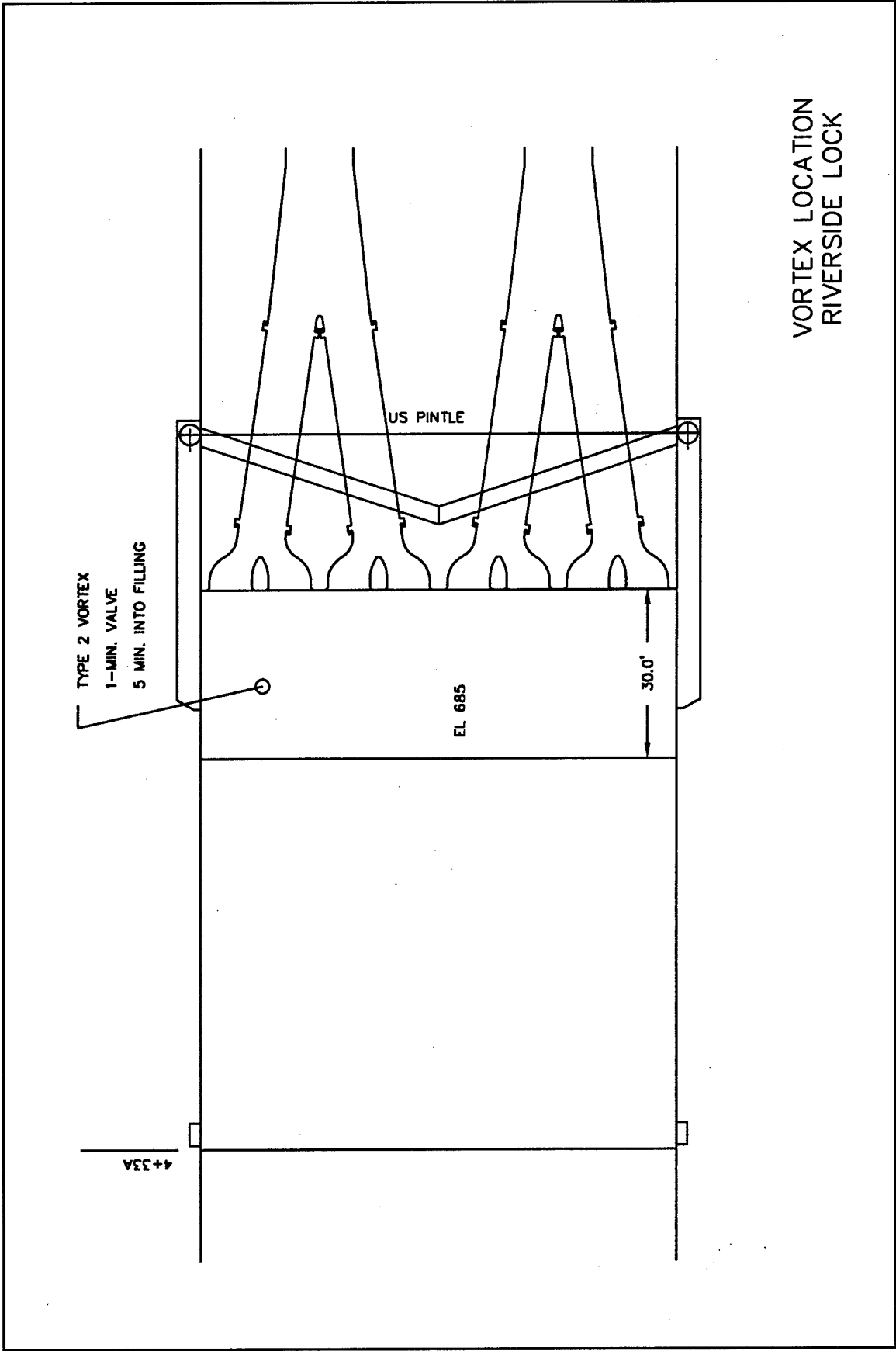

VORTEX LOCATION
 RIVERSIDE LOCK

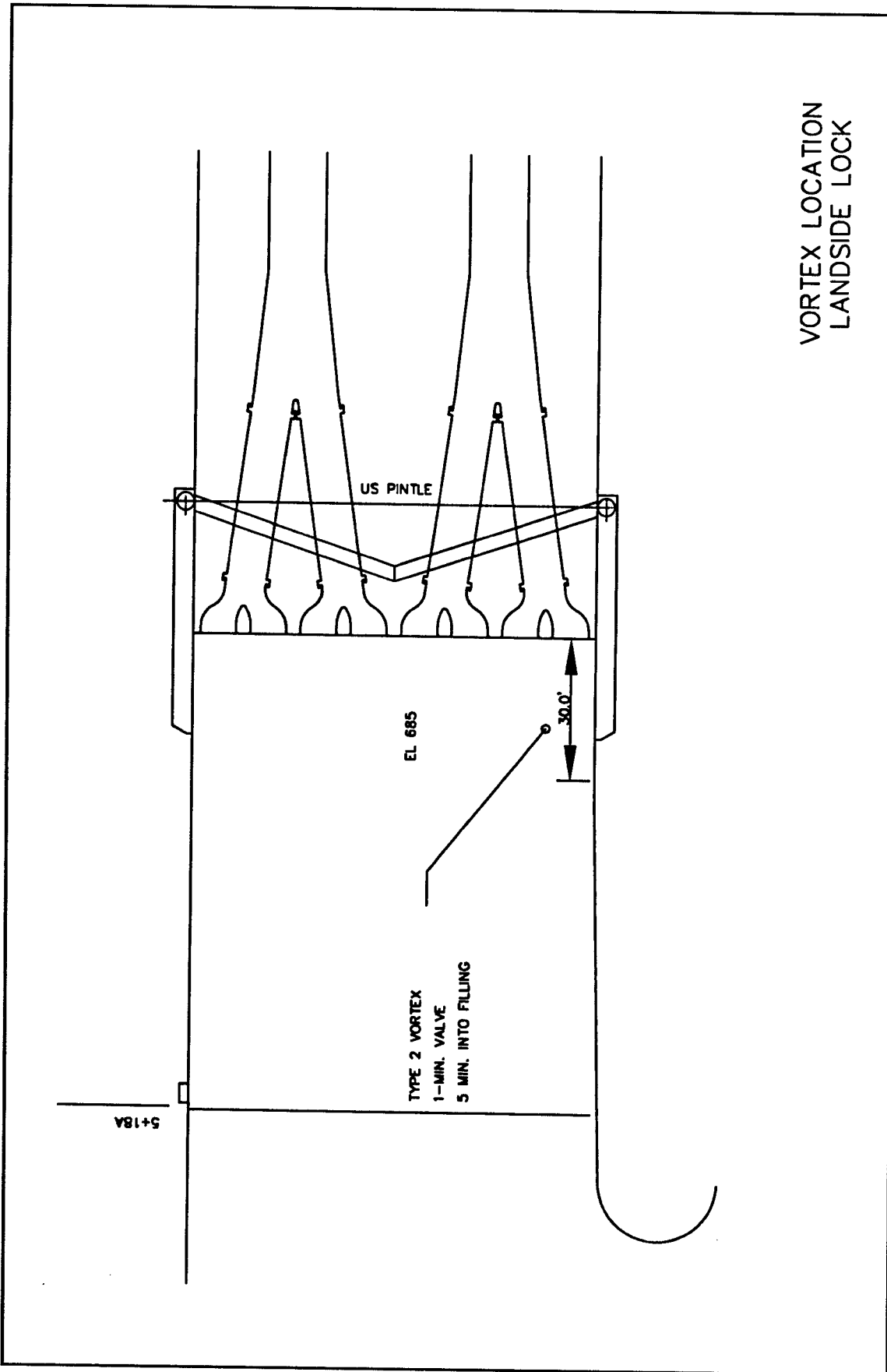

VORTEX LOCATION
LANDSIDE LOCK

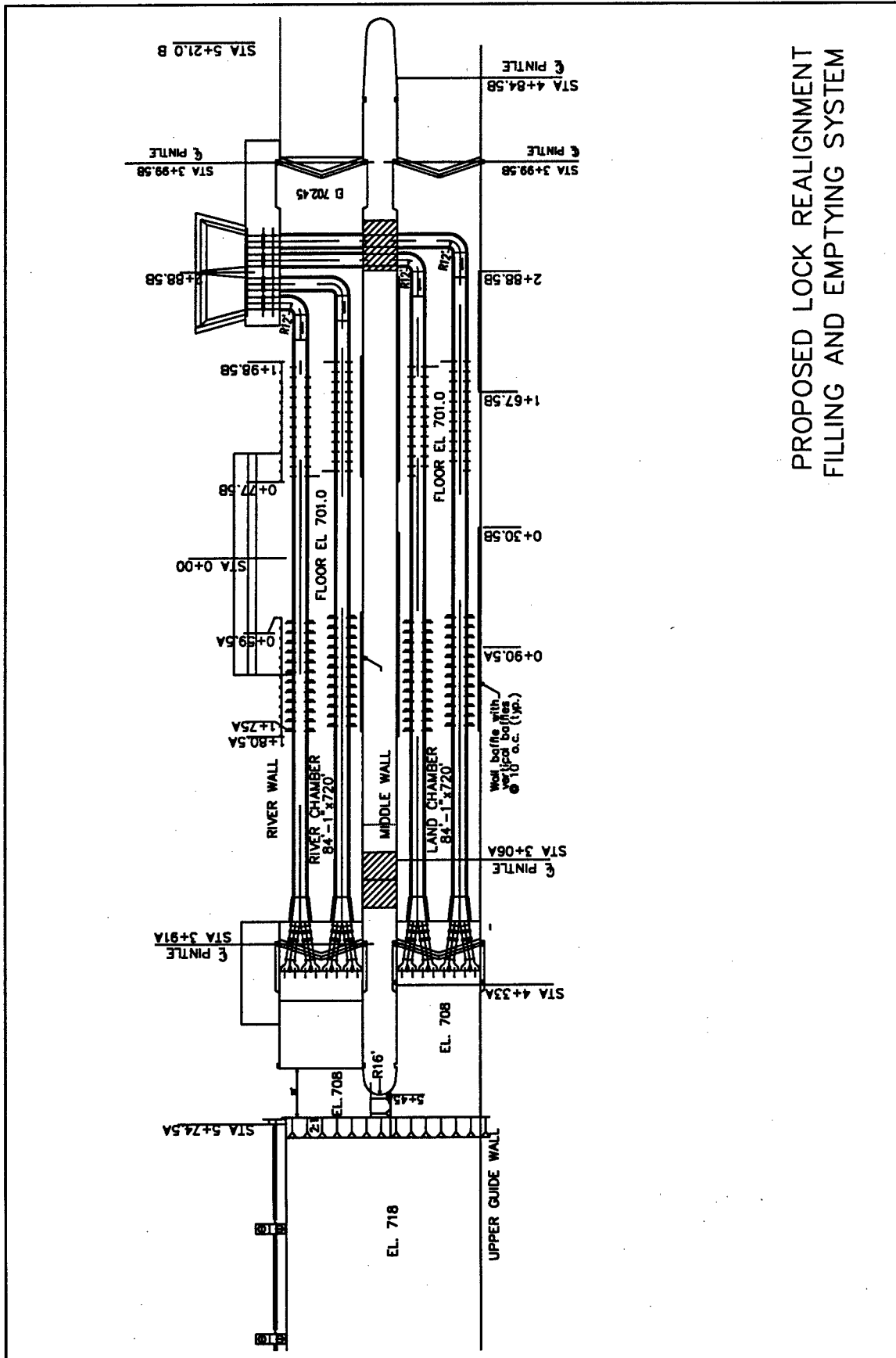

PROPOSED LOCK REALIGNMENT
 FILLING AND EMPTYING SYSTEM

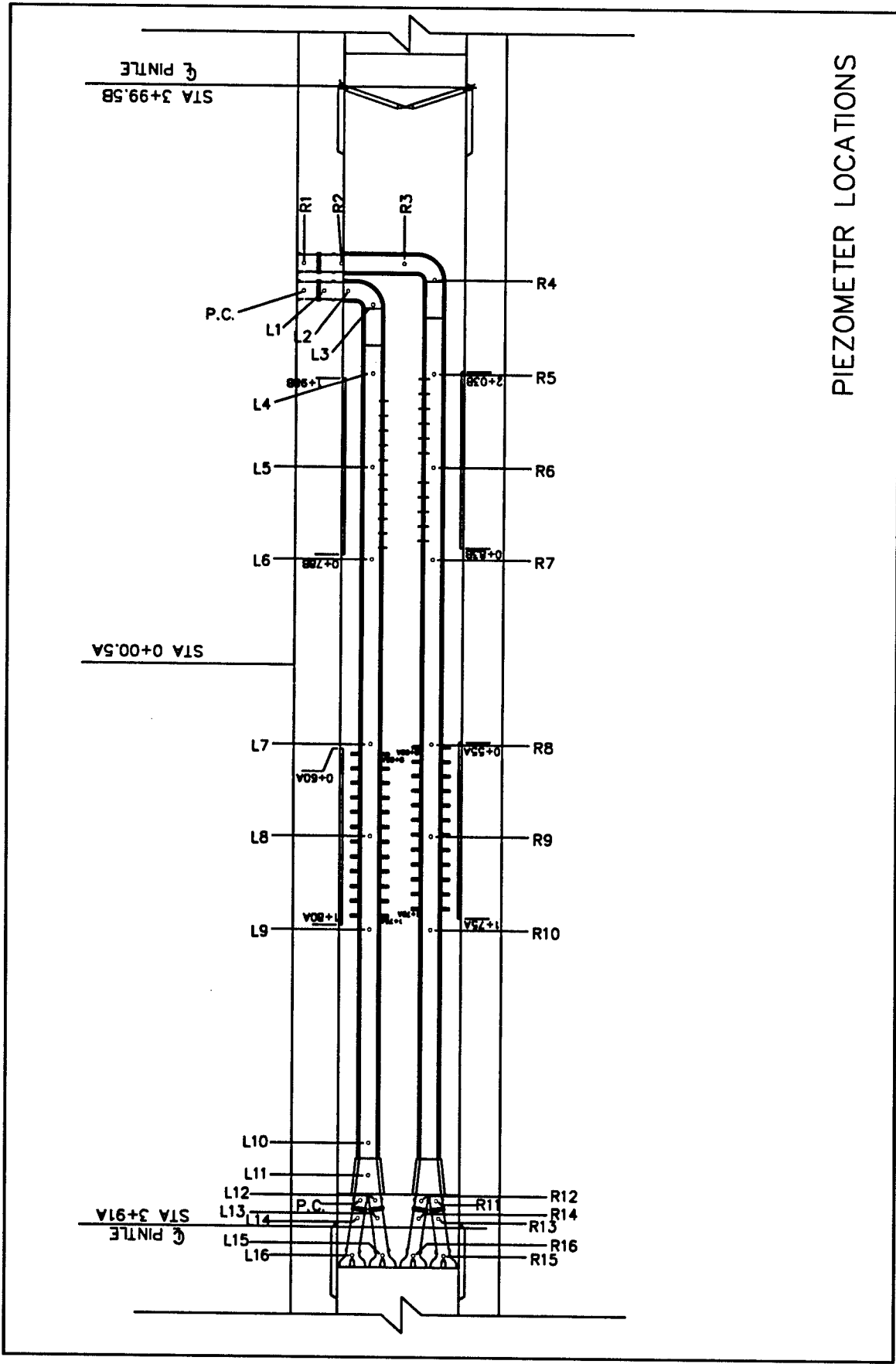

PIEZOMETER LOCATIONS

Plate 10

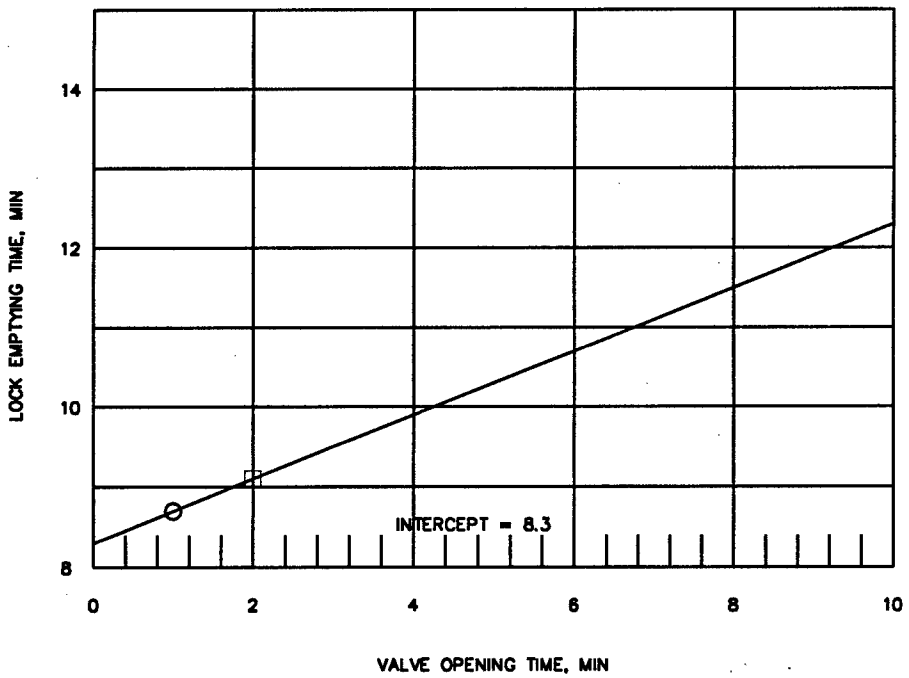
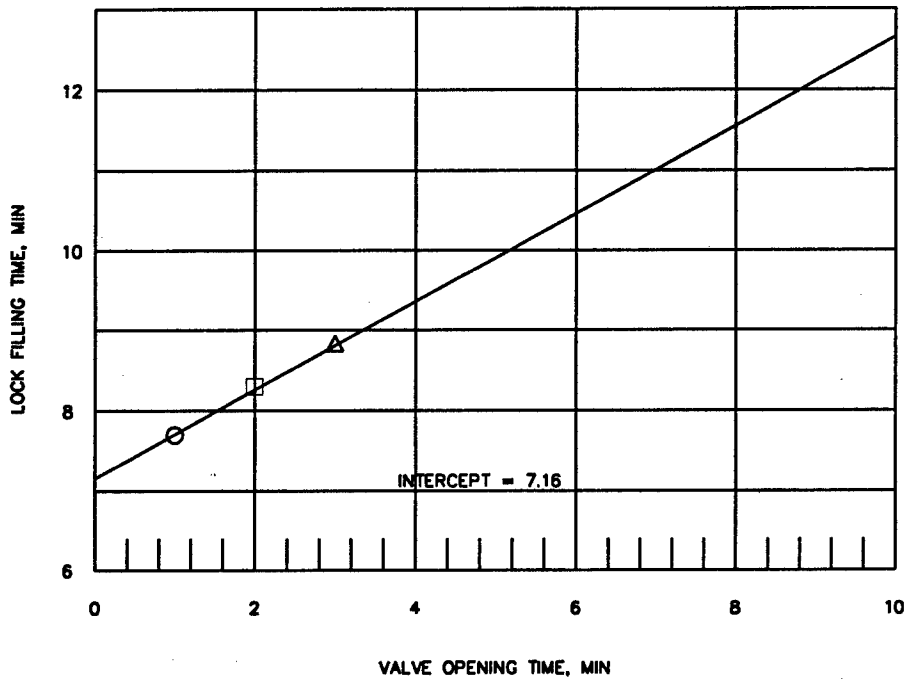

LEGEND	
SYMBOL	VALVE SPEED
○	1
□	2
△	3

OPERATING CONDITIONS
19.8-FT LIFT

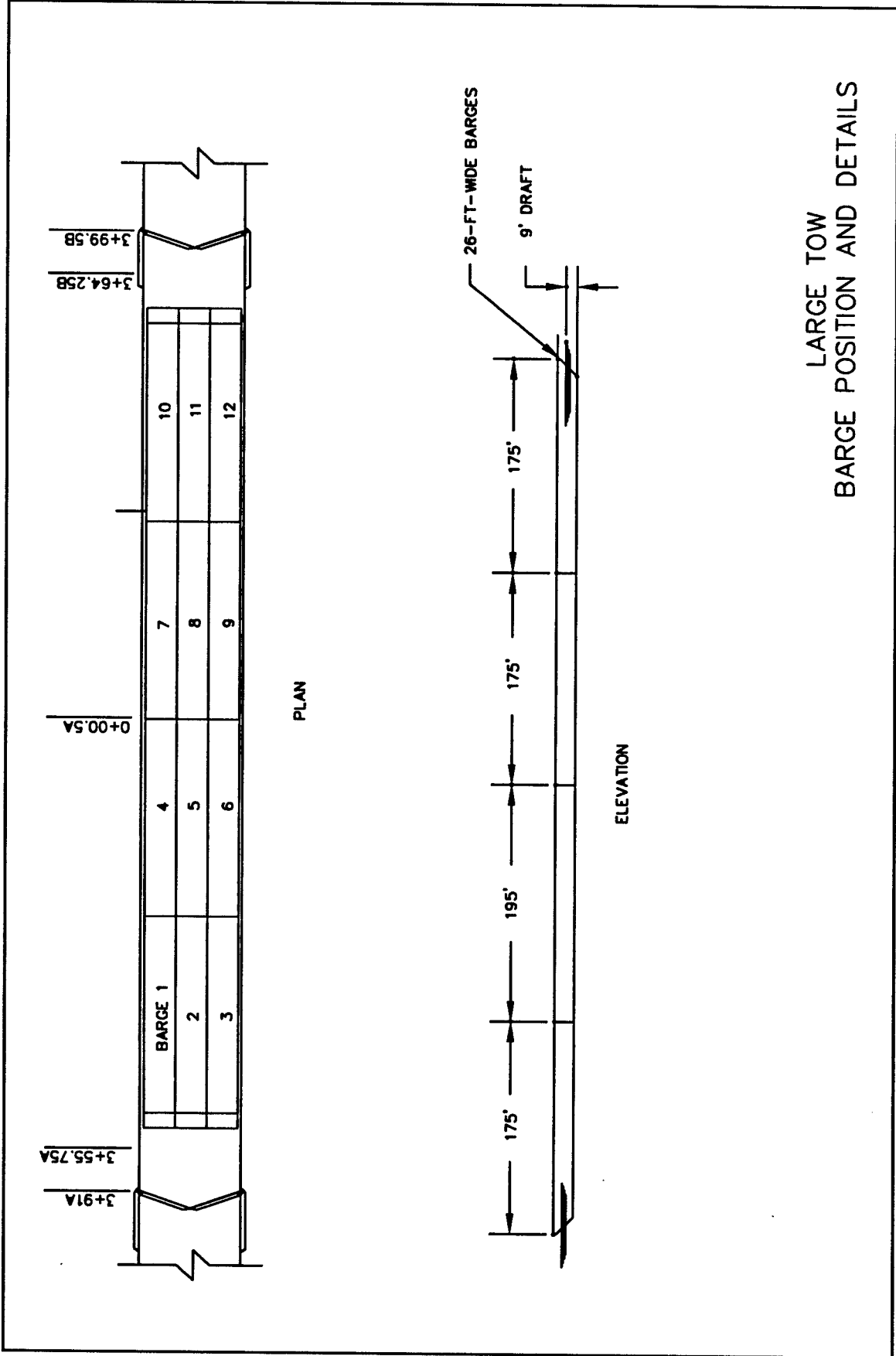

LARGE TOW
BARGE POSITION AND DETAILS

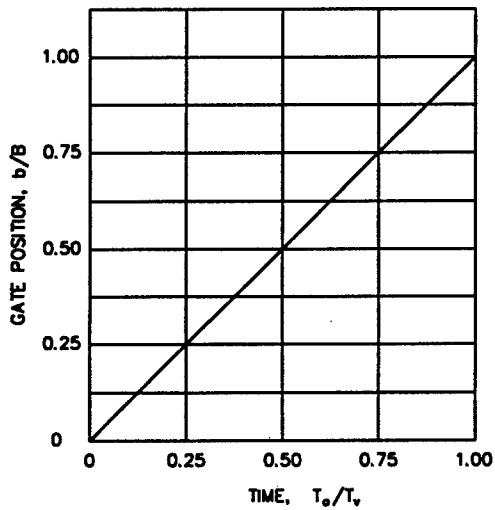
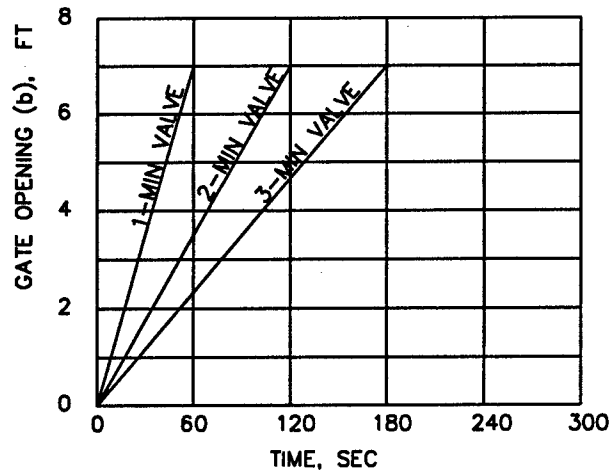

b/B	T_o/T_v
0	0
0.10	0.10
0.20	0.20
0.30	0.30
0.40	0.40
0.50	0.50
0.60	0.60
0.70	0.70
0.80	0.80
0.90	0.90
1.00	1.00

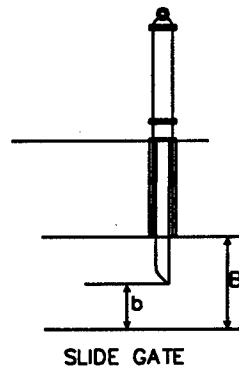

T_o = TIME SINCE OPENING BEGAN

T_v = TIME TO OPEN FULL

B = 7 FT (2.13 m)

b = VERTICAL DIST. FROM LIP TO FLOOR

LINEAR DESIGN VALVE OPENING CURVES

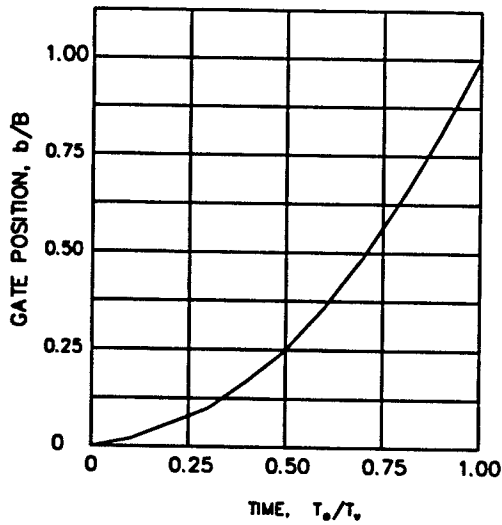
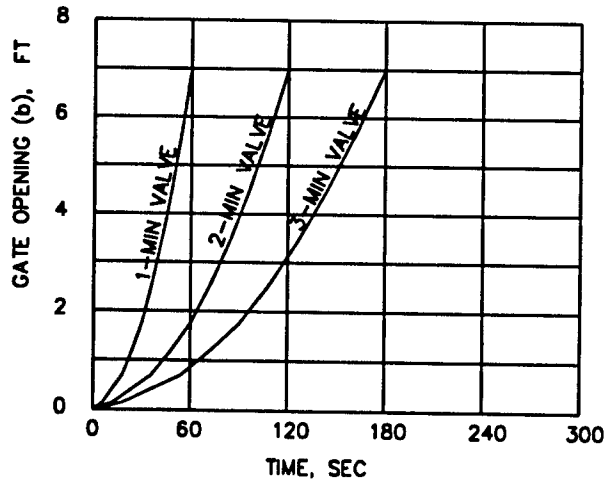

b/B	T_o/T_v
0	0
0.02	0.10
0.06	0.20
0.10	0.30
0.17	0.40
0.25	0.50
0.36	0.60
0.49	0.70
0.64	0.80
0.81	0.90
1.00	1.00

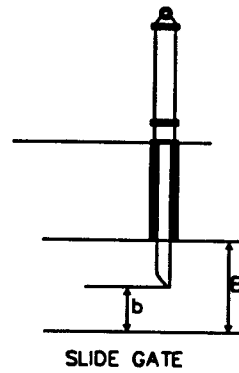

T_o = TIME SINCE OPENING BEGAN
 T_v = TIME TO OPEN FULL
 B = 7 FT (2.13 m)
 b = VERTICAL DIST. FROM LIP TO FLOOR

0.25 SAG DESIGN VALVE OPENING CURVES

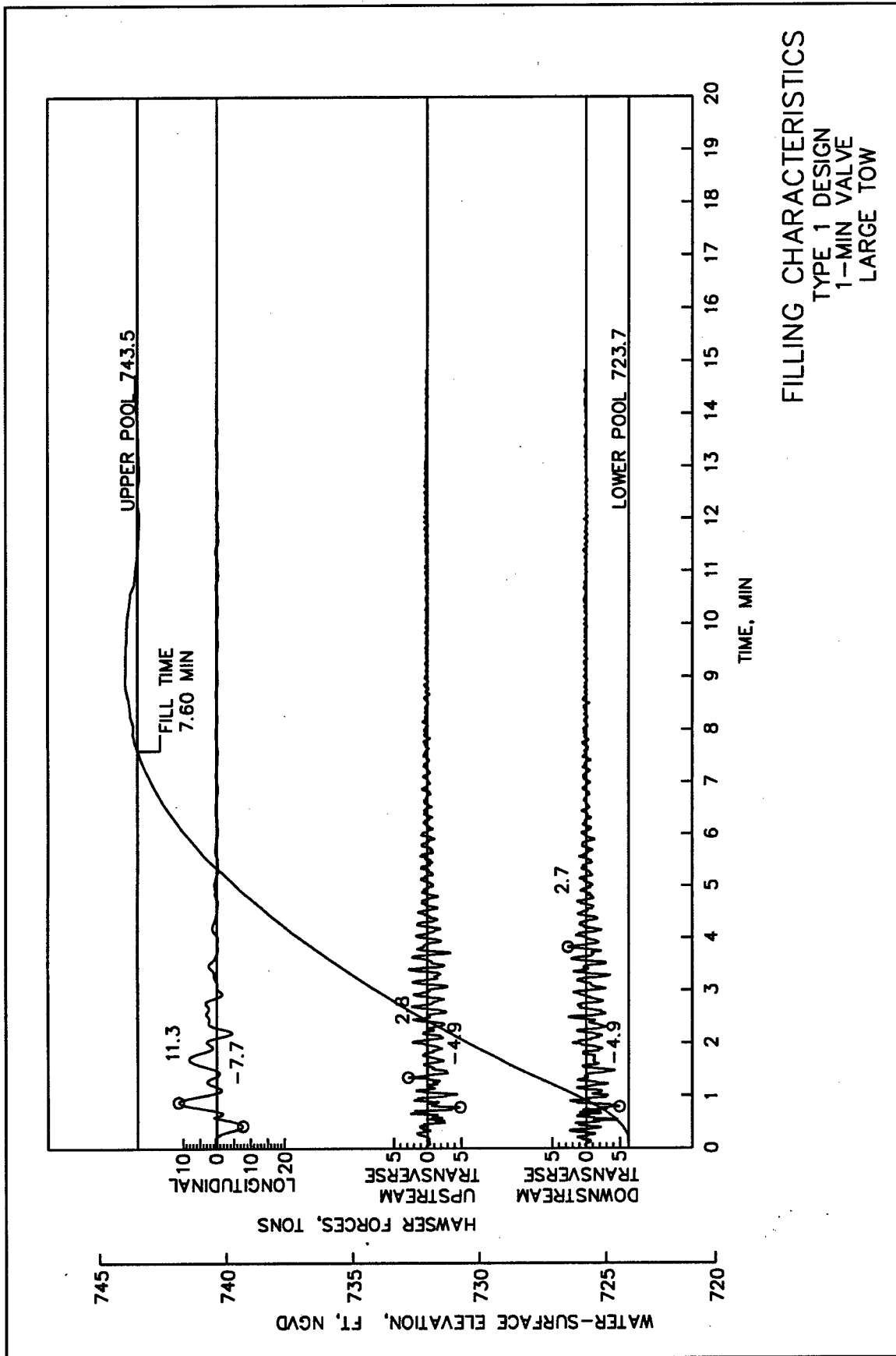

FILLING CHARACTERISTICS
 TYPE 1 DESIGN
 1-MIN VALVE
 LARGE TOW

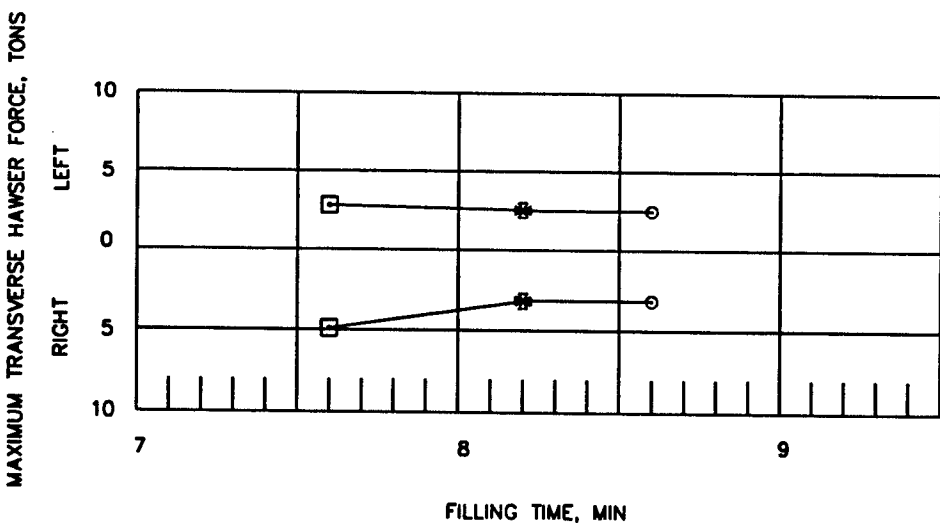
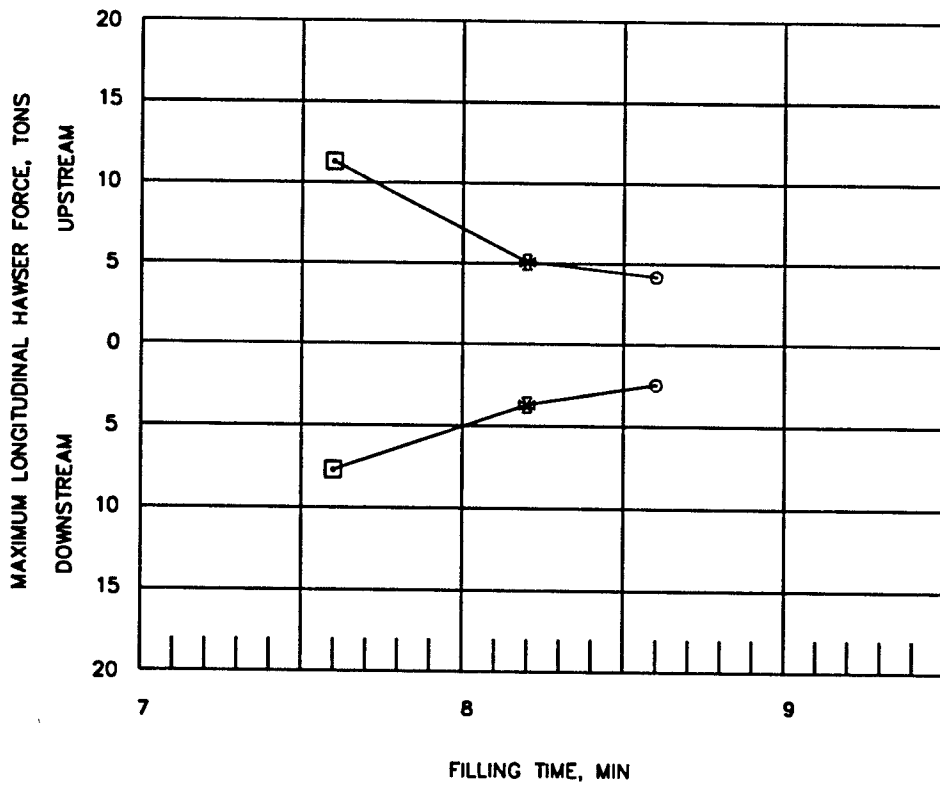

LEGEND	
SYMBOL	VALVE SPEED
□	1
⊗	2
○	3

HAWSER FORCES
 DURING FILLING
 TYPE 1 DESIGN
 LARGE TOW
 19.8-FT LIFT

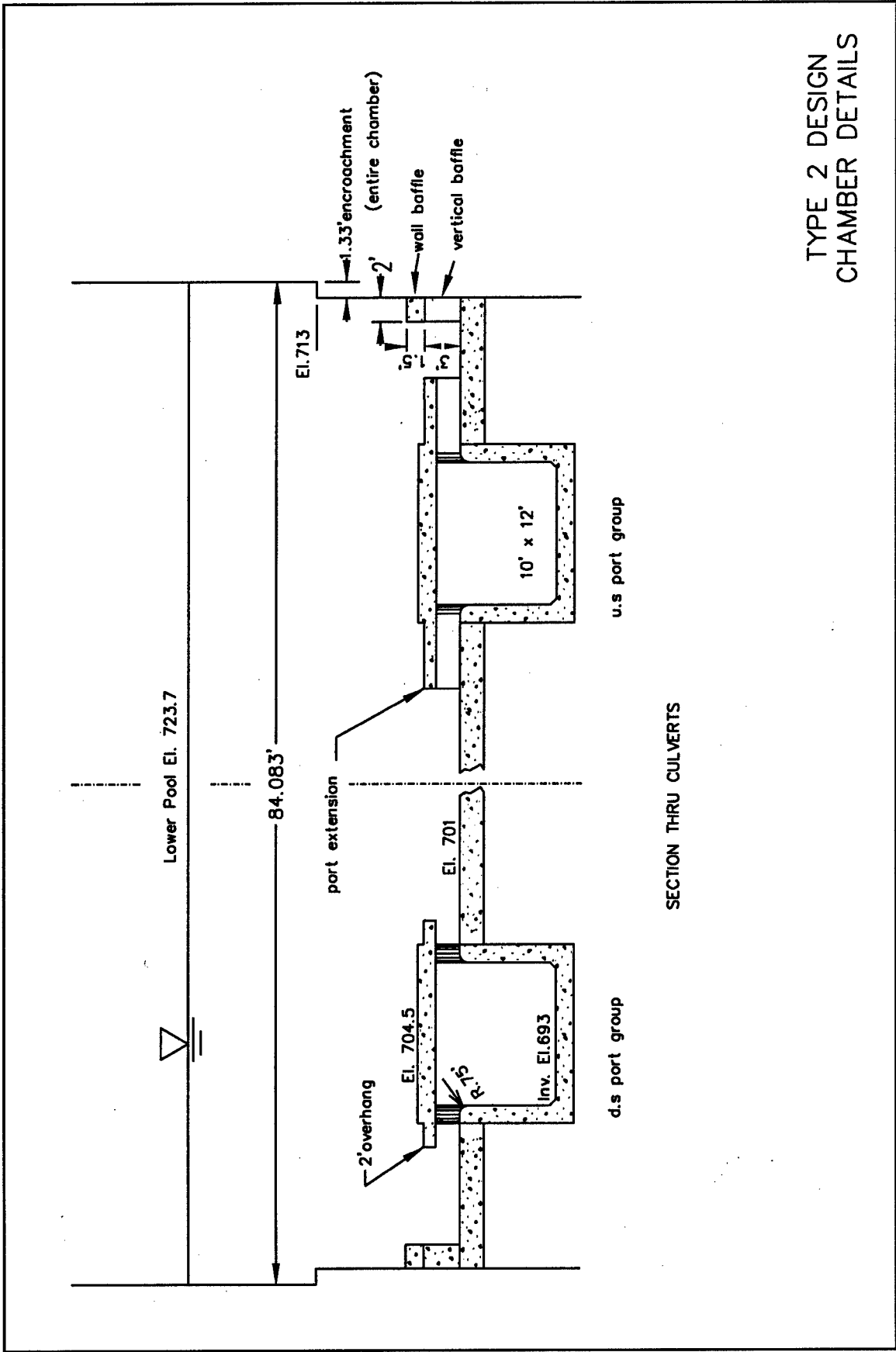

TYPE 2 DESIGN
 CHAMBER DETAILS

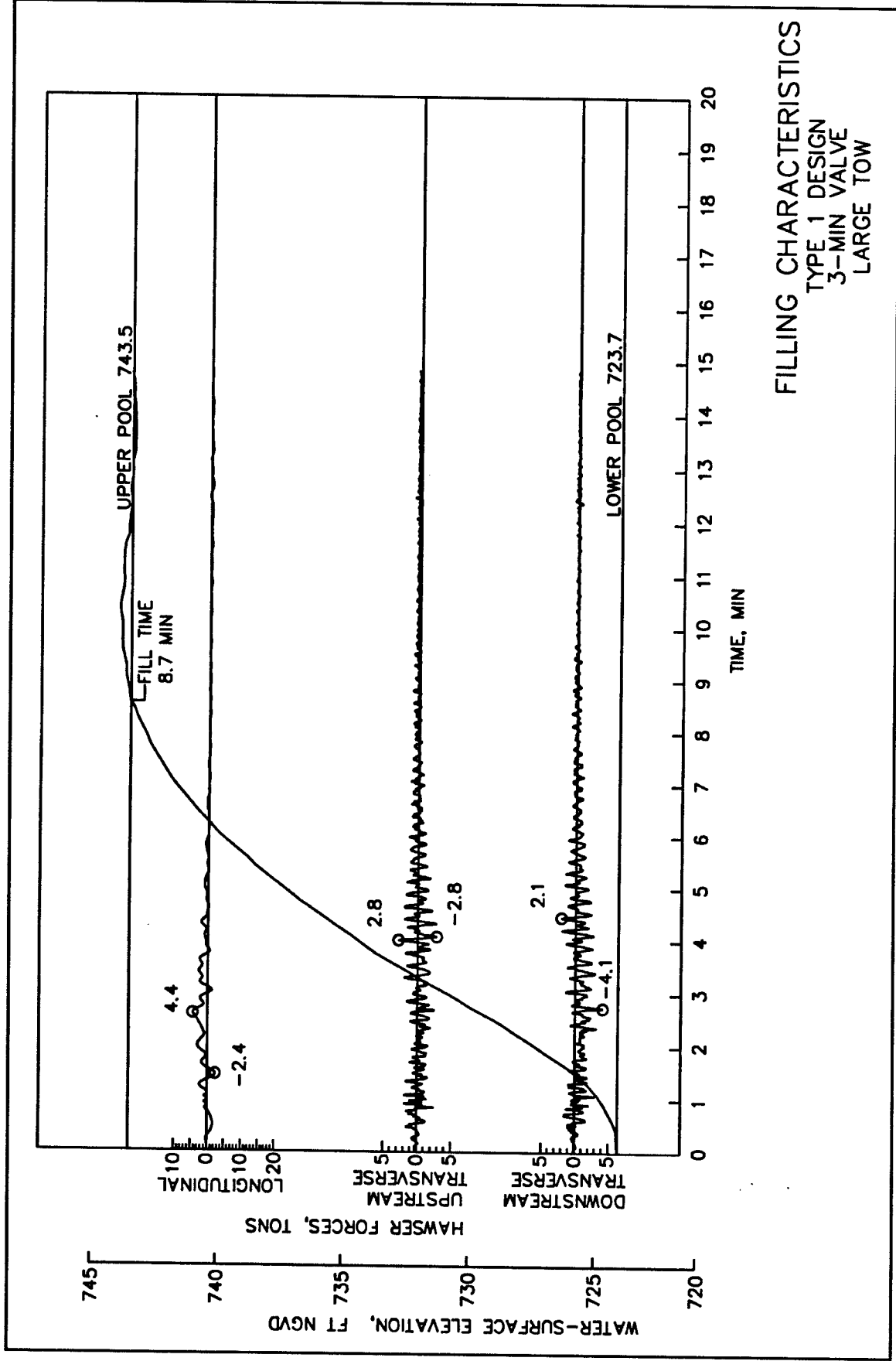

FILLING CHARACTERISTICS
 TYPE 1 DESIGN
 3-MIN VALVE
 LARGE TOW

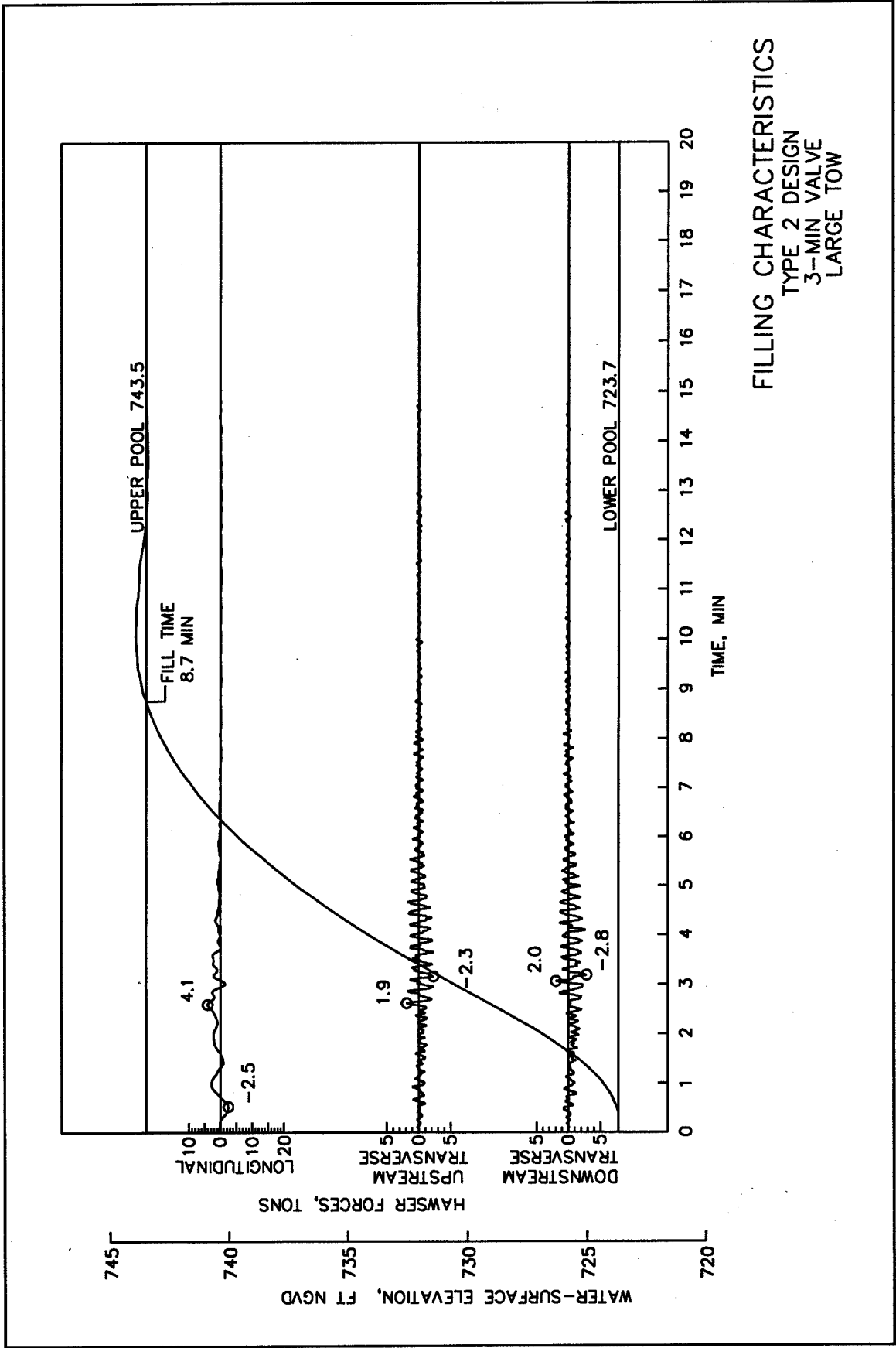

FILLING CHARACTERISTICS
 TYPE 2 DESIGN
 3-MIN VALVE
 LARGE TOW

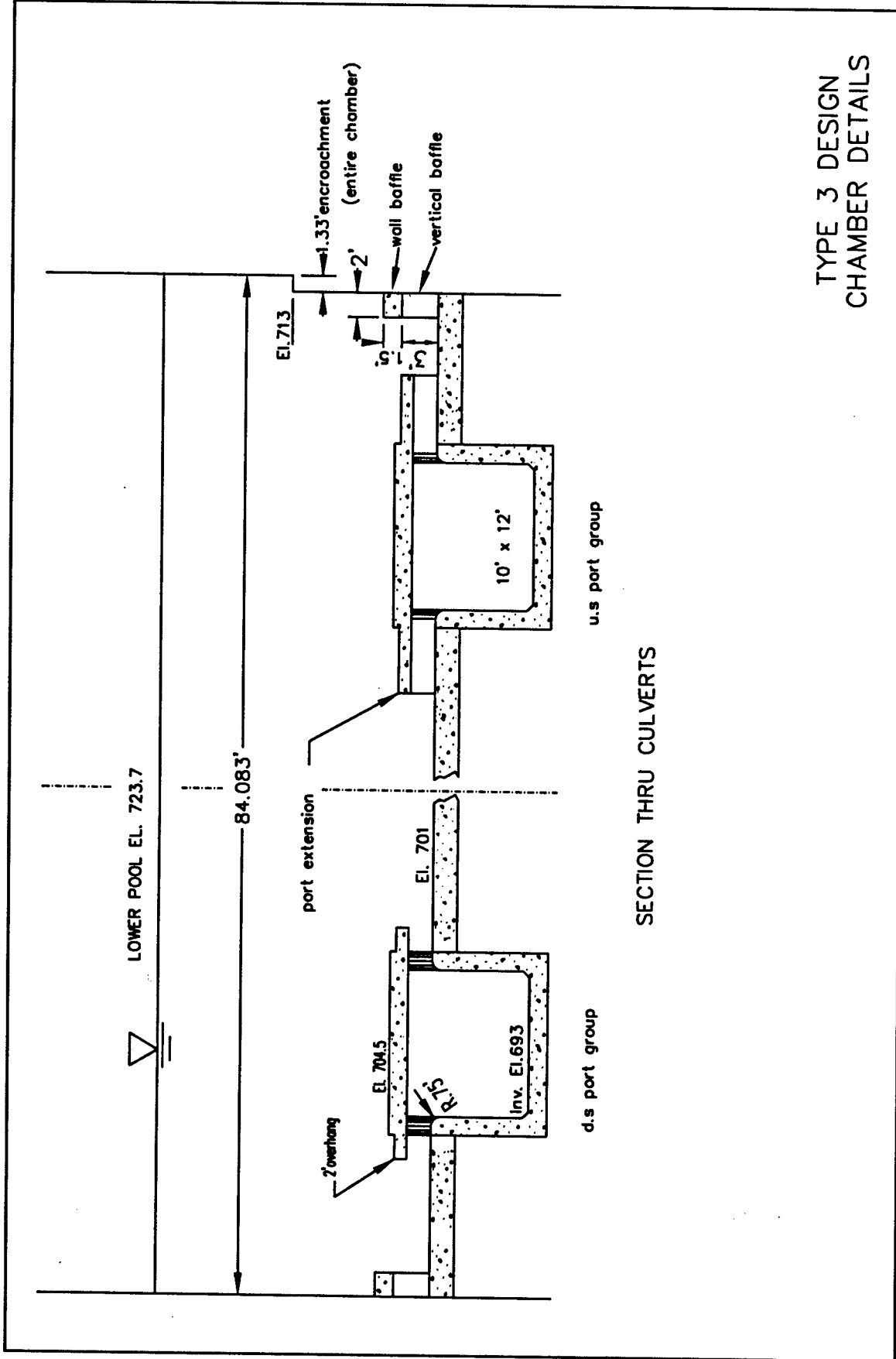

TYPE 3 DESIGN
CHAMBER DETAILS

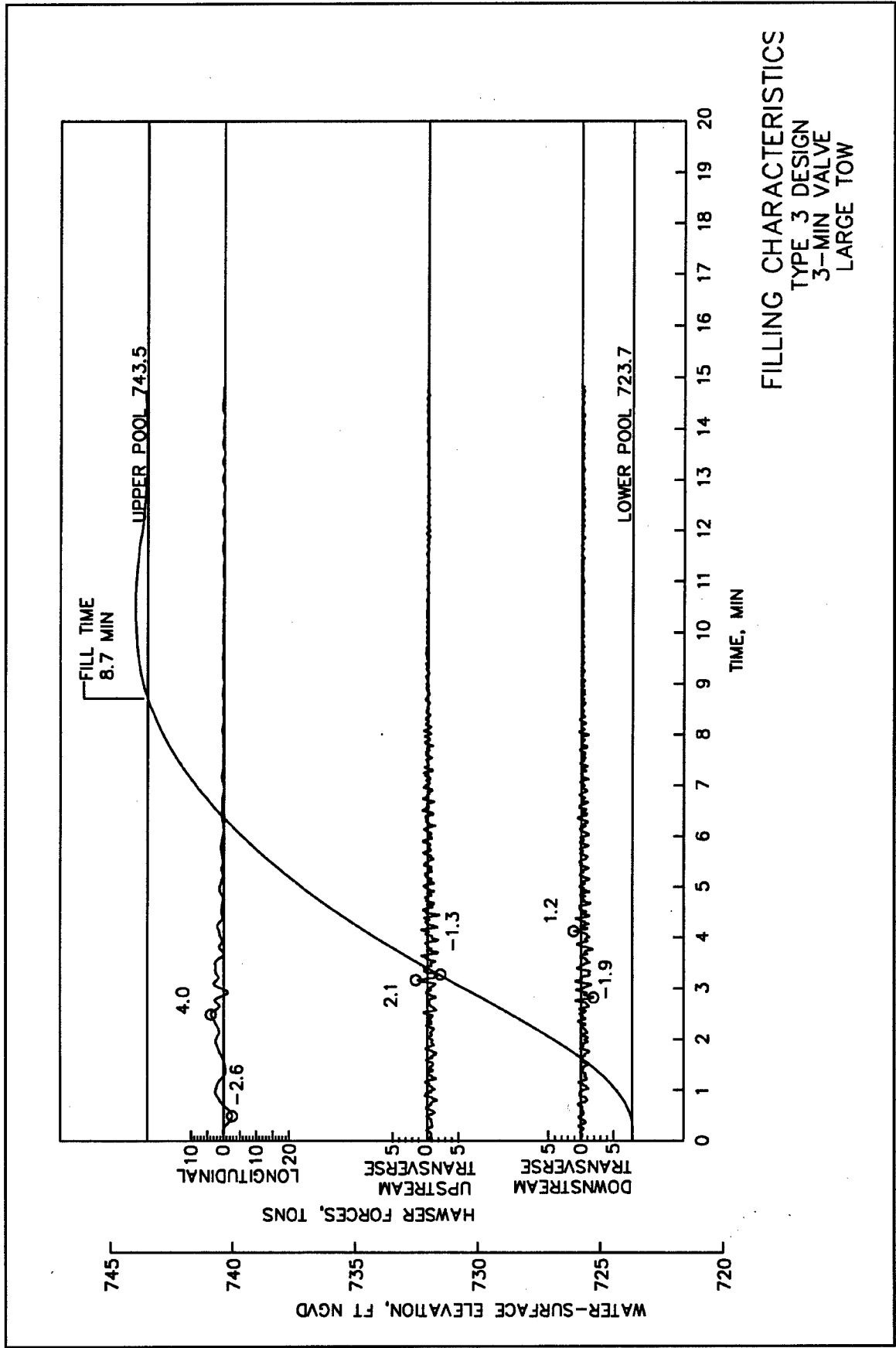

FILLING CHARACTERISTICS
 TYPE 3 DESIGN
 3-MIN VALVE
 LARGE TOW

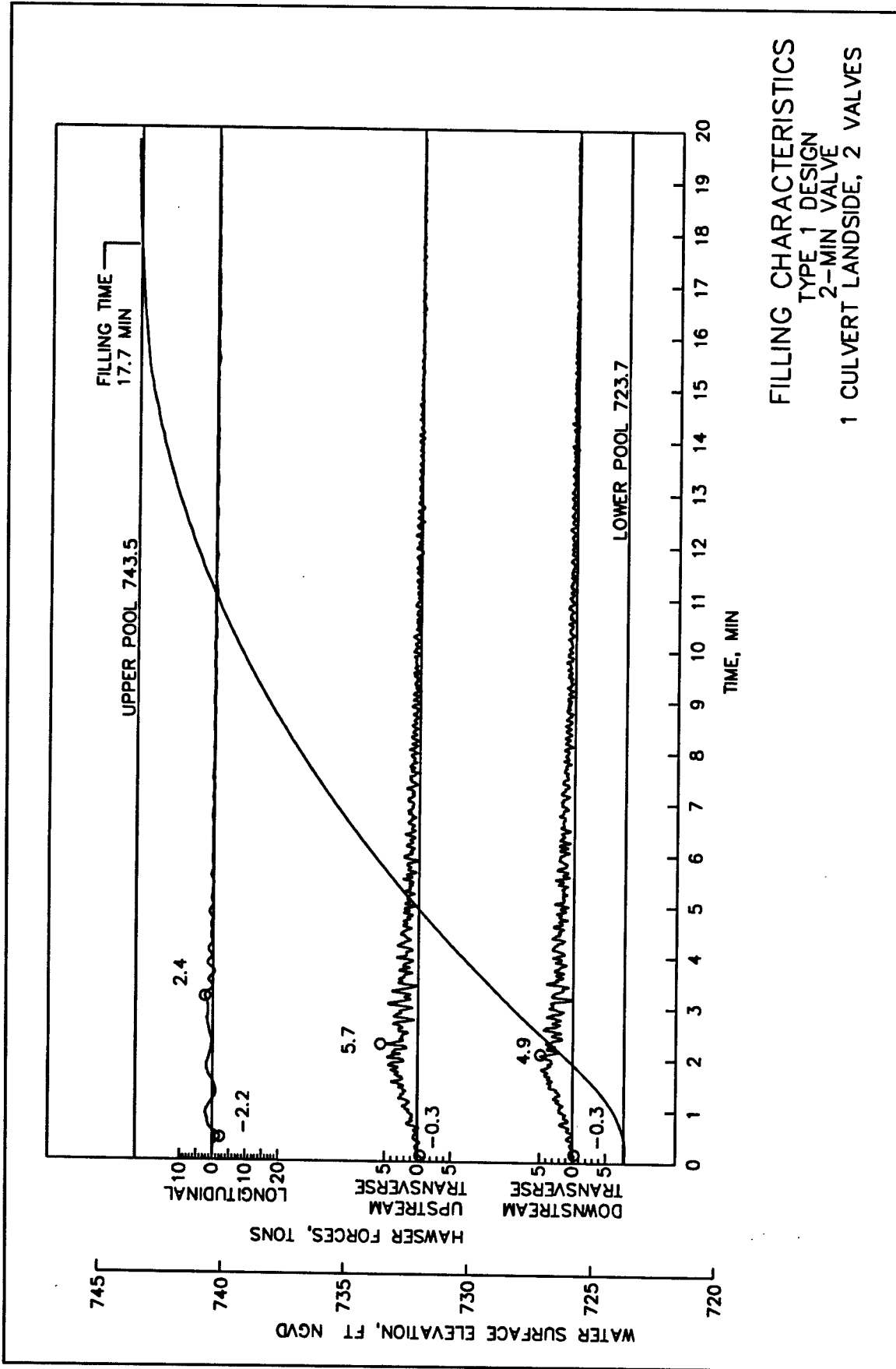

FILLING CHARACTERISTICS
 TYPE 1 DESIGN
 2-MIN VALVE
 1 CULVERT LANDSIDE, 2 VALVES

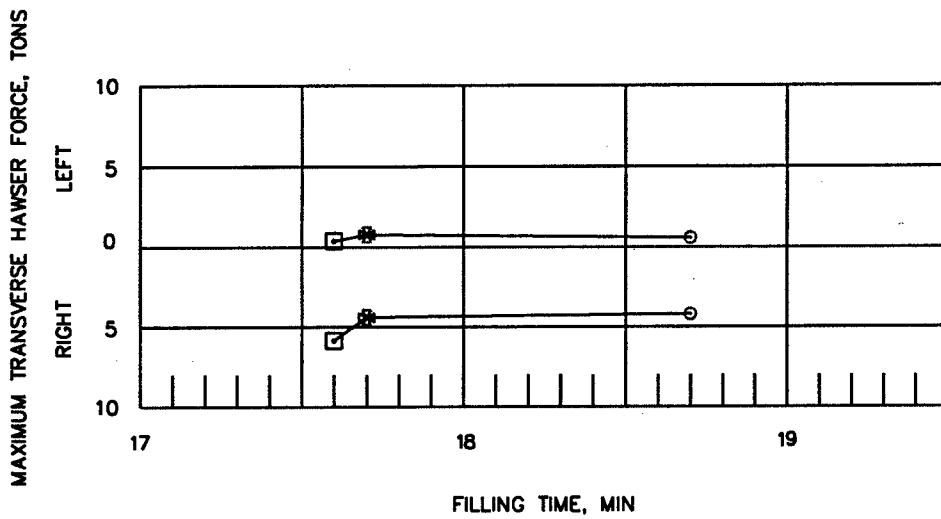
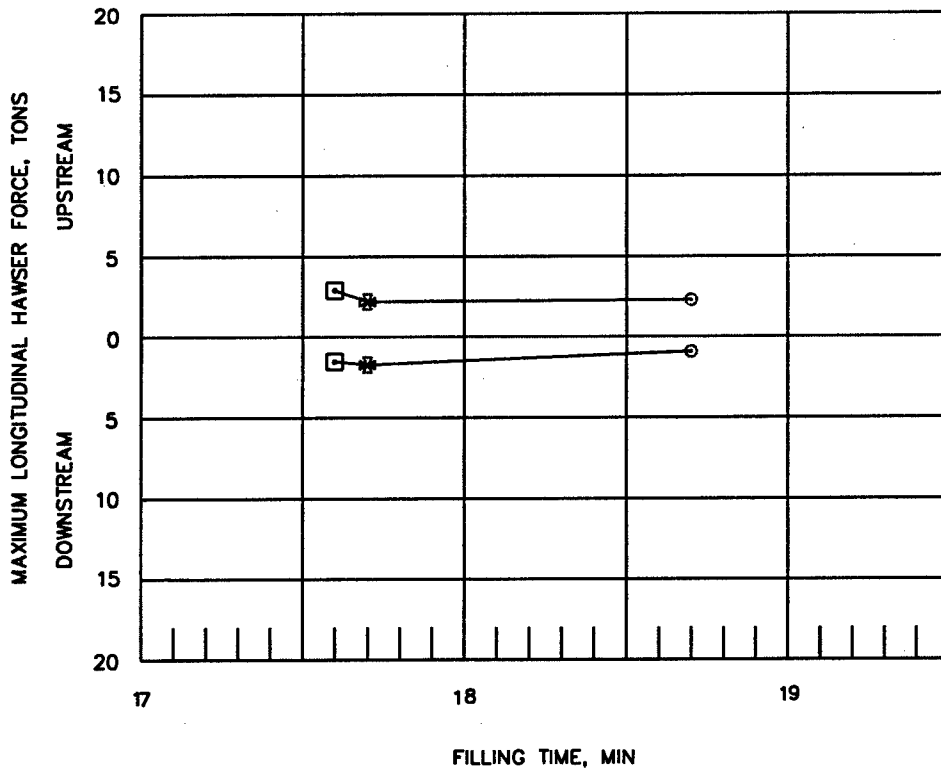

LEGEND	
SYMBOL	VALVE SPEED
□	2
⊠	3
○	4

HAWSER FORCES
 DURING FILLING
 TYPE 1 DESIGN
 LARGE TOW
 19.8-FT LIFT
 1 CULVERT LANDSIDE, 2 VALVES

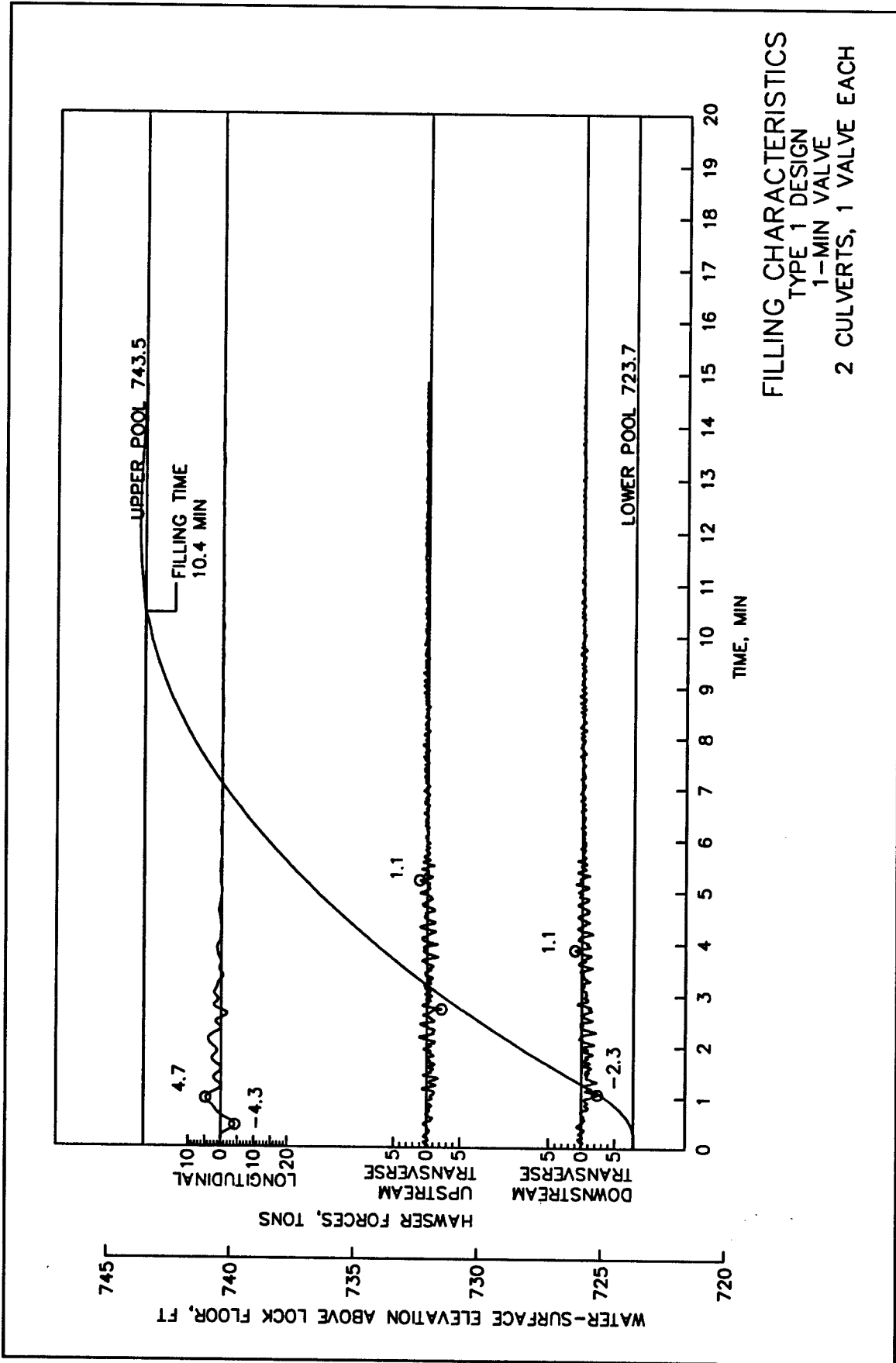

FILLING CHARACTERISTICS
TYPE 1 DESIGN
1-MIN VALVE
2 CULVERTS, 1 VALVE EACH

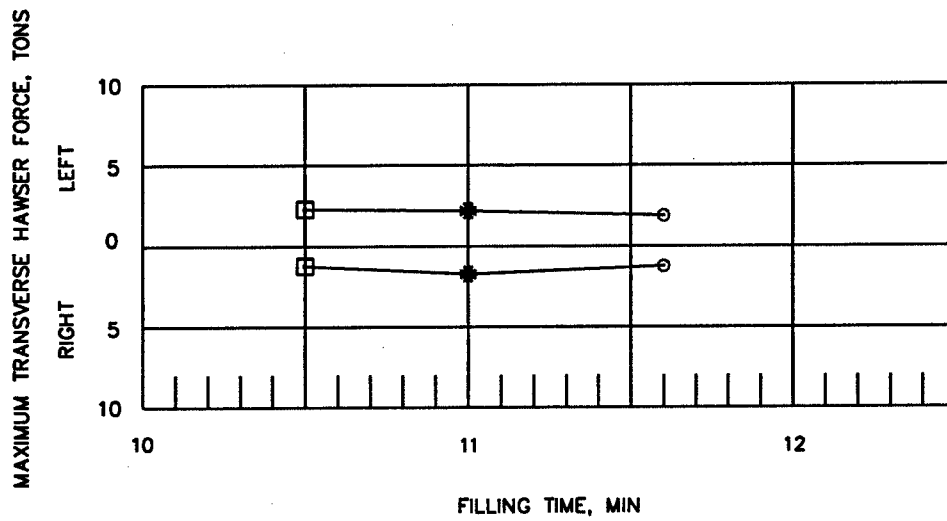
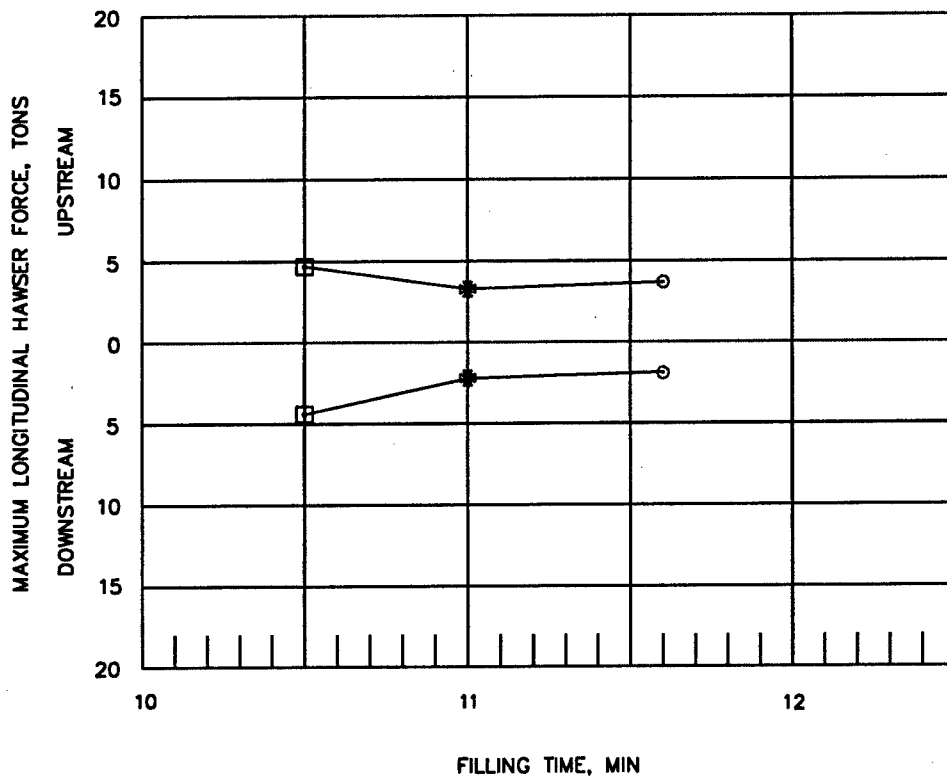

LEGEND	
SYMBOL	VALVE SPEED
□	1
■	2
○	3

HAWSER FORCES
 DURING FILLING
 TYPE 1 DESIGN
 LARGE TOW
 19.8-FT LIFT
 2 CULVERTS, 1 VALVE EACH

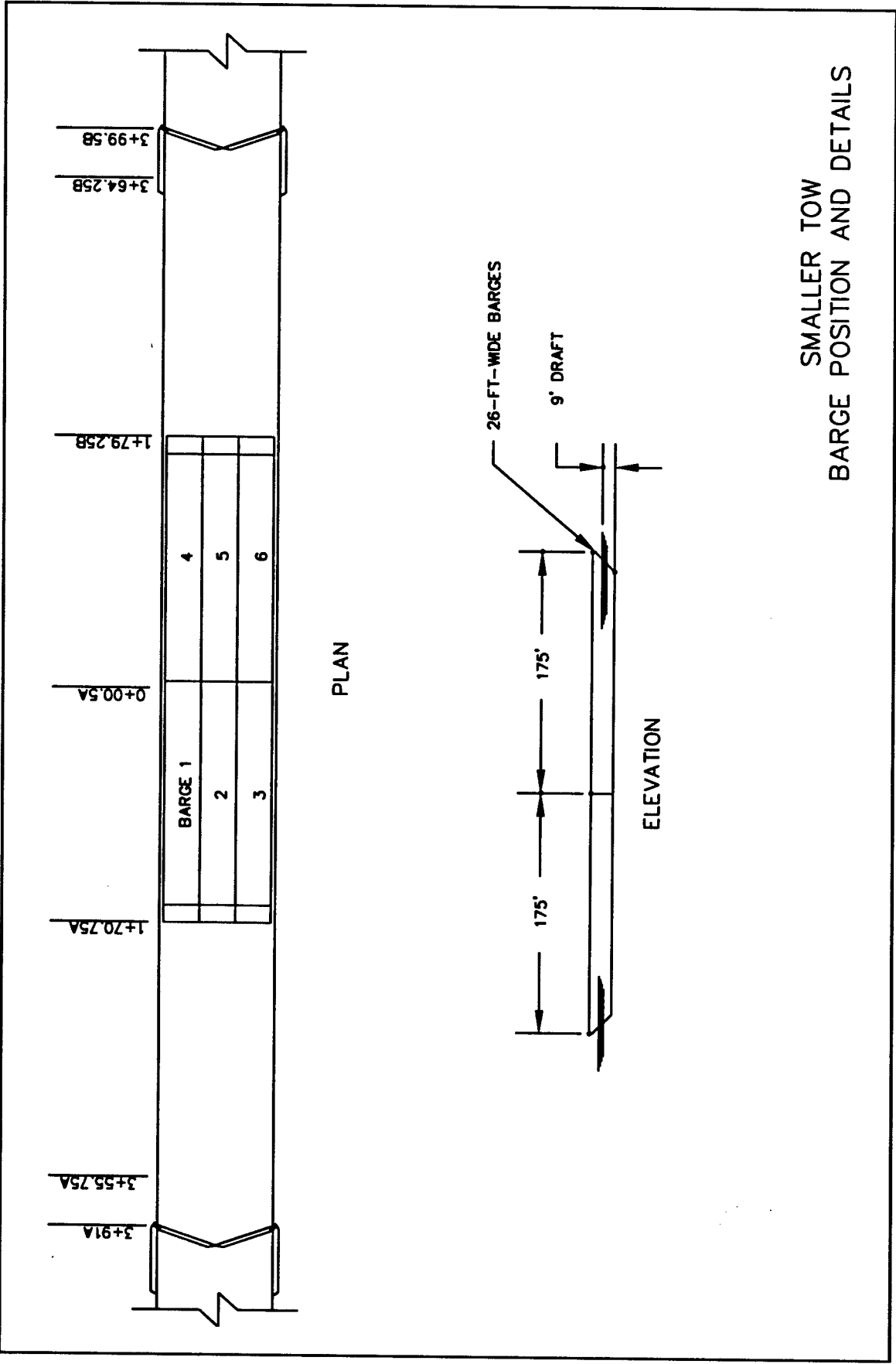

SMALLER TOW
BARGE POSITION AND DETAILS

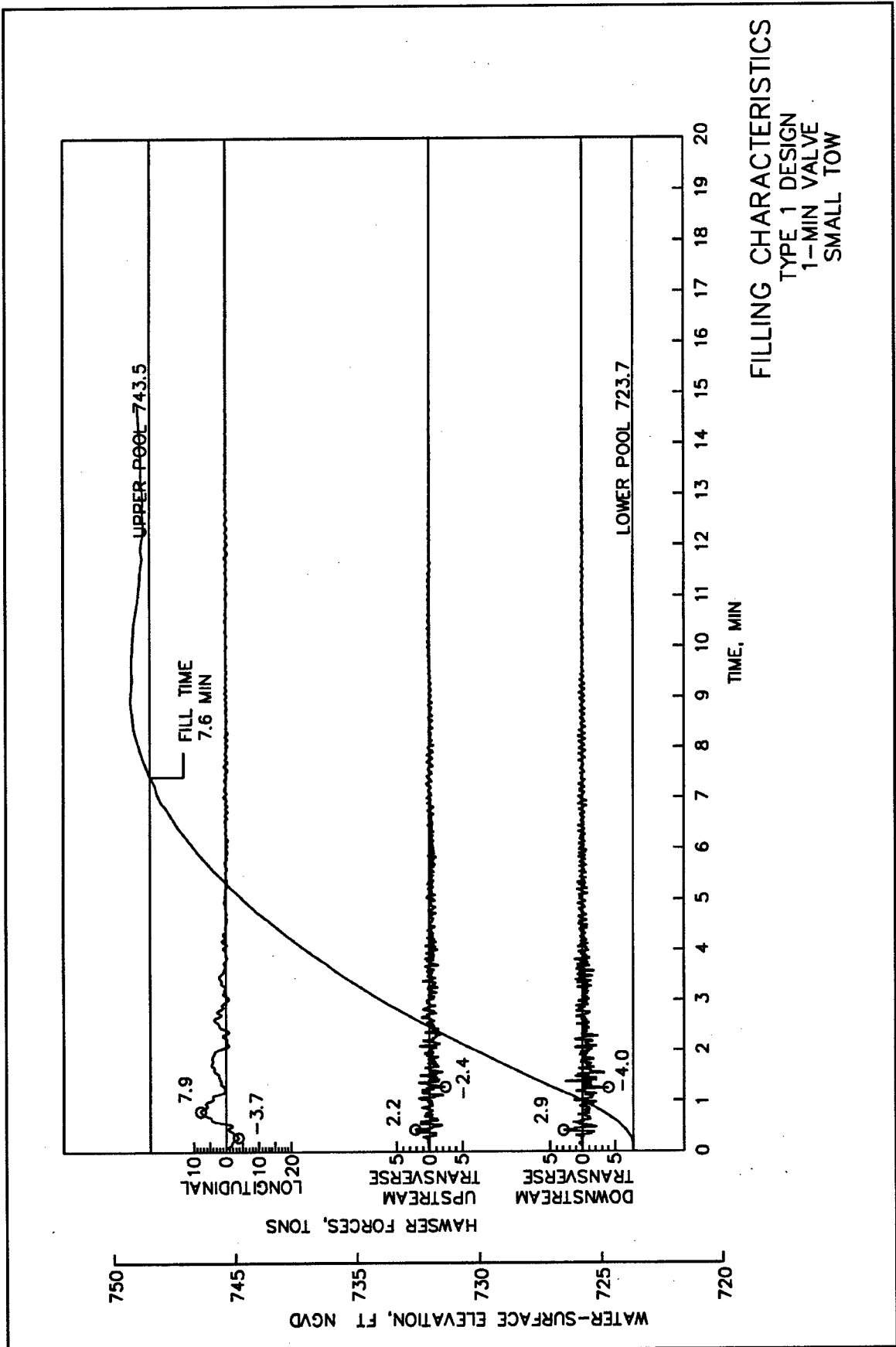

FILLING CHARACTERISTICS
 TYPE 1 DESIGN
 1-MIN VALVE
 SMALL TOW

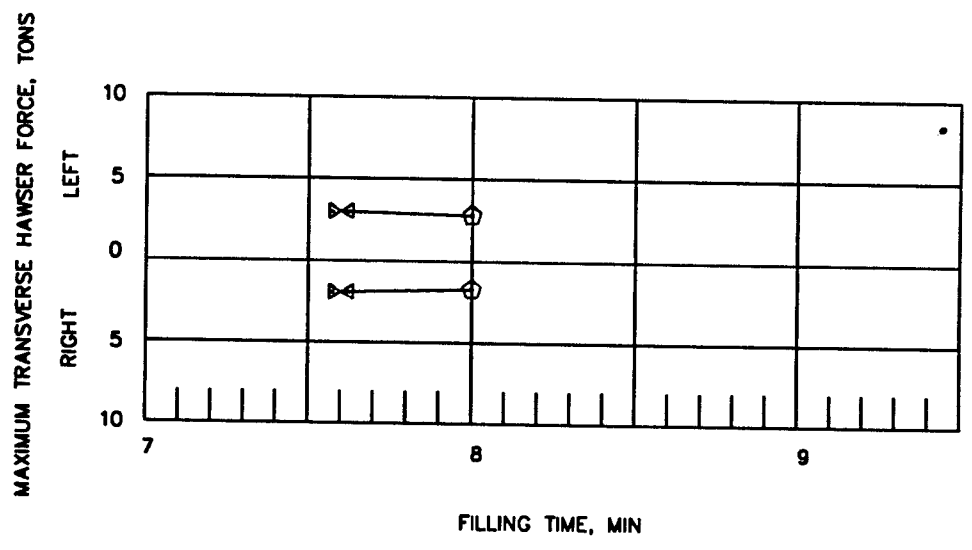
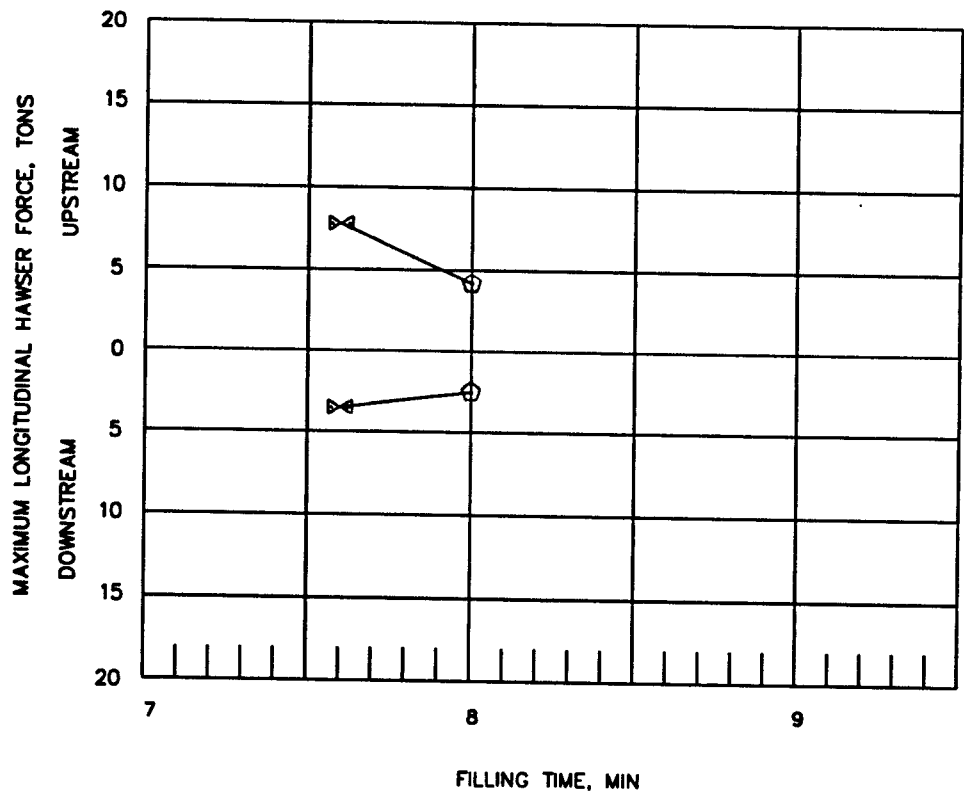

LEGEND	
SYMBOL	VALVE SPEED
△	1
○	2

HAWSER FORCES
 DURING FILLING
 TYPE 1 DESIGN
 SMALL TOW
 19.8-FT LIFT

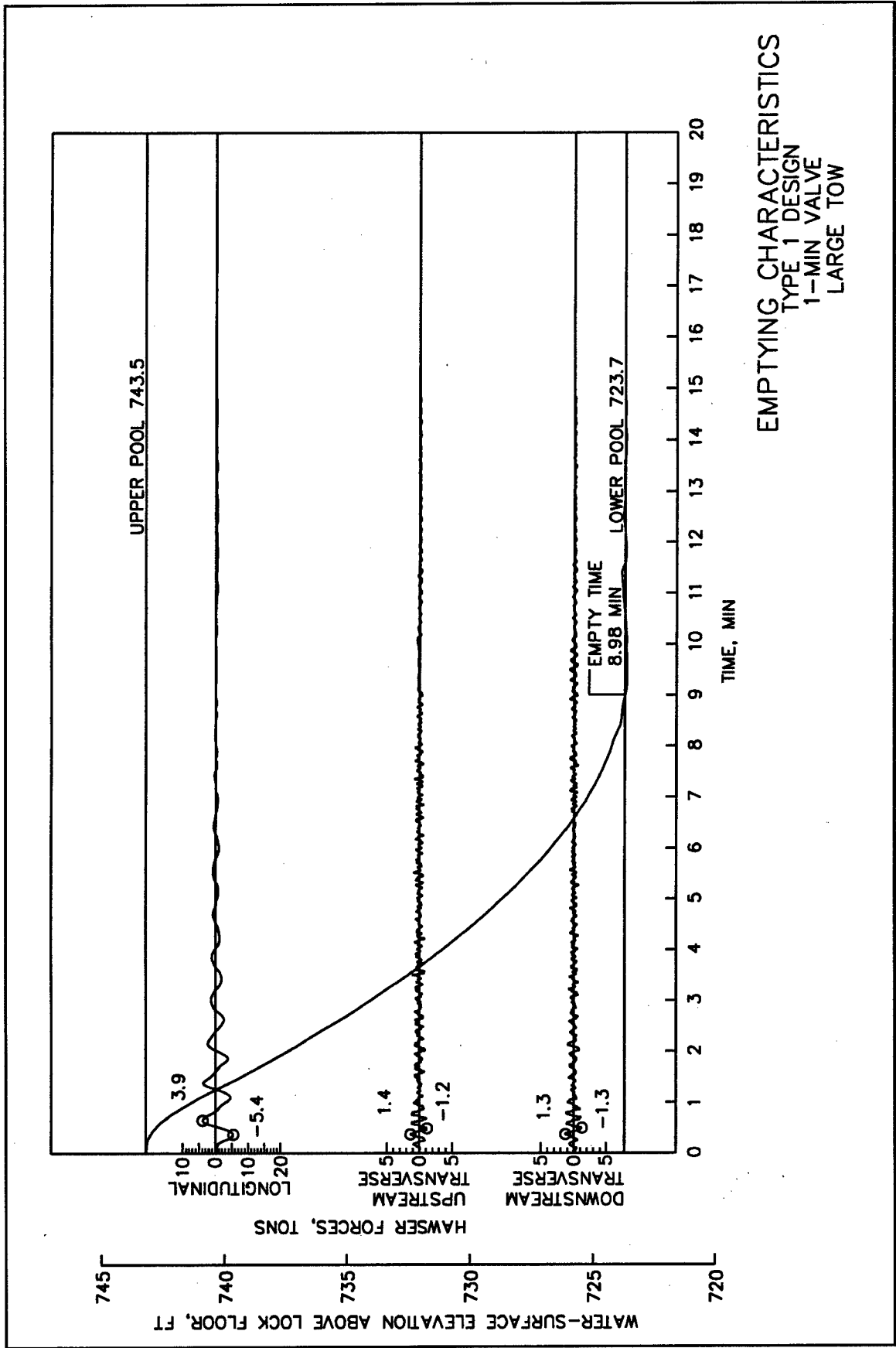

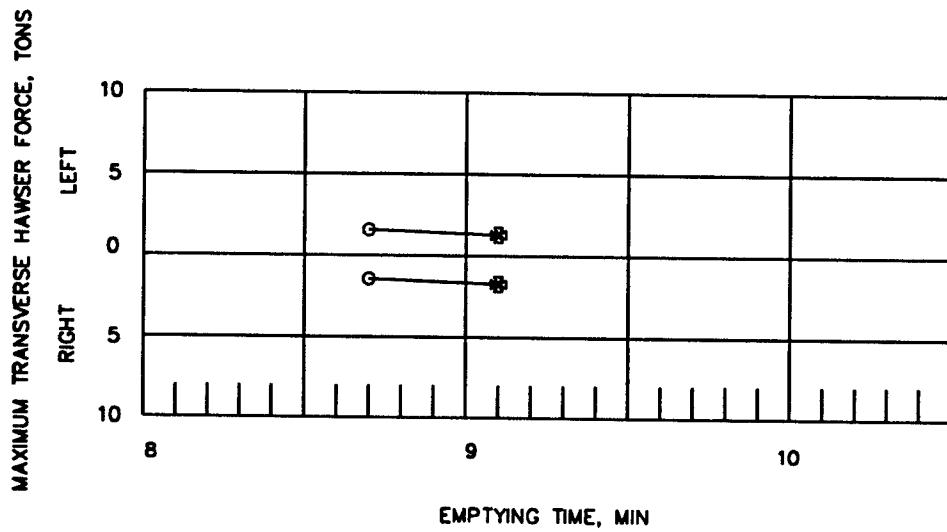
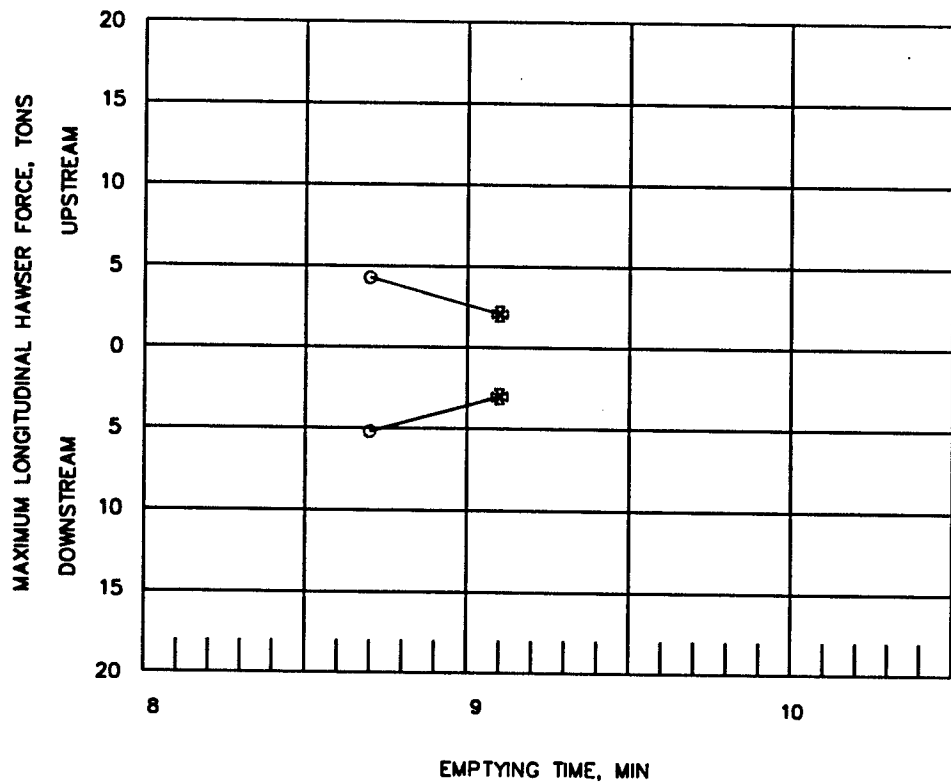

LEGEND	
SYMBOL	VALVE SPEED
○	1
✱	2

HAWSER FORCES
 DURING EMPTYING
 TYPE 1 DESIGN
 LARGE TOW
 19.8-FT LIFT

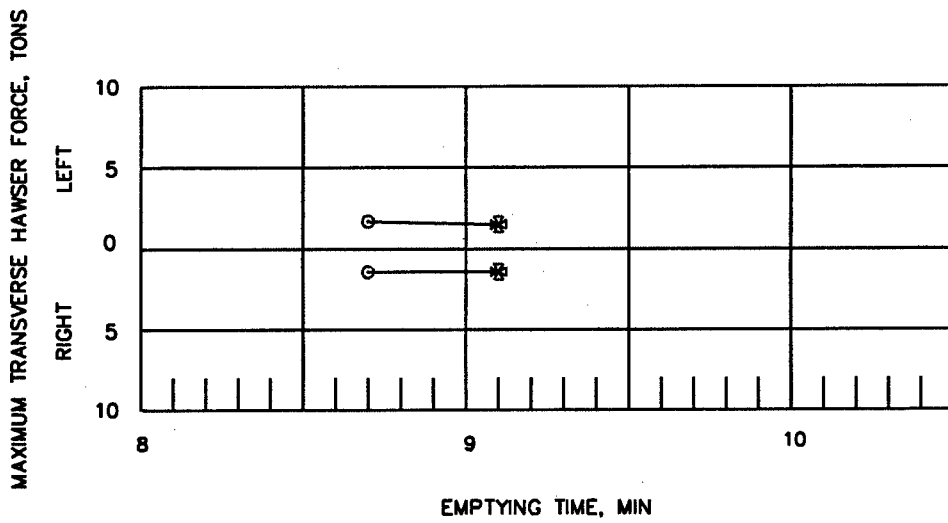
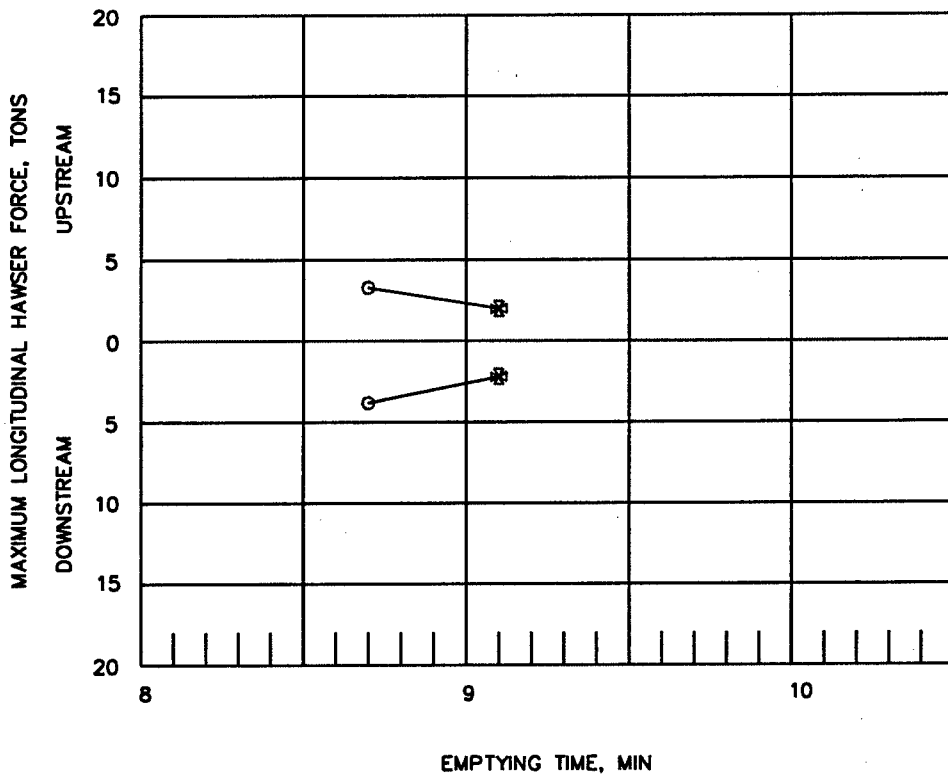

LEGEND		
SYMBOL	VALVE	SPEED
○	1	
*	2	

HAWSER FORCES
 DURING EMPTYING
 TYPE 1 DESIGN
 SMALL TOW
 19.8-FT LIFT

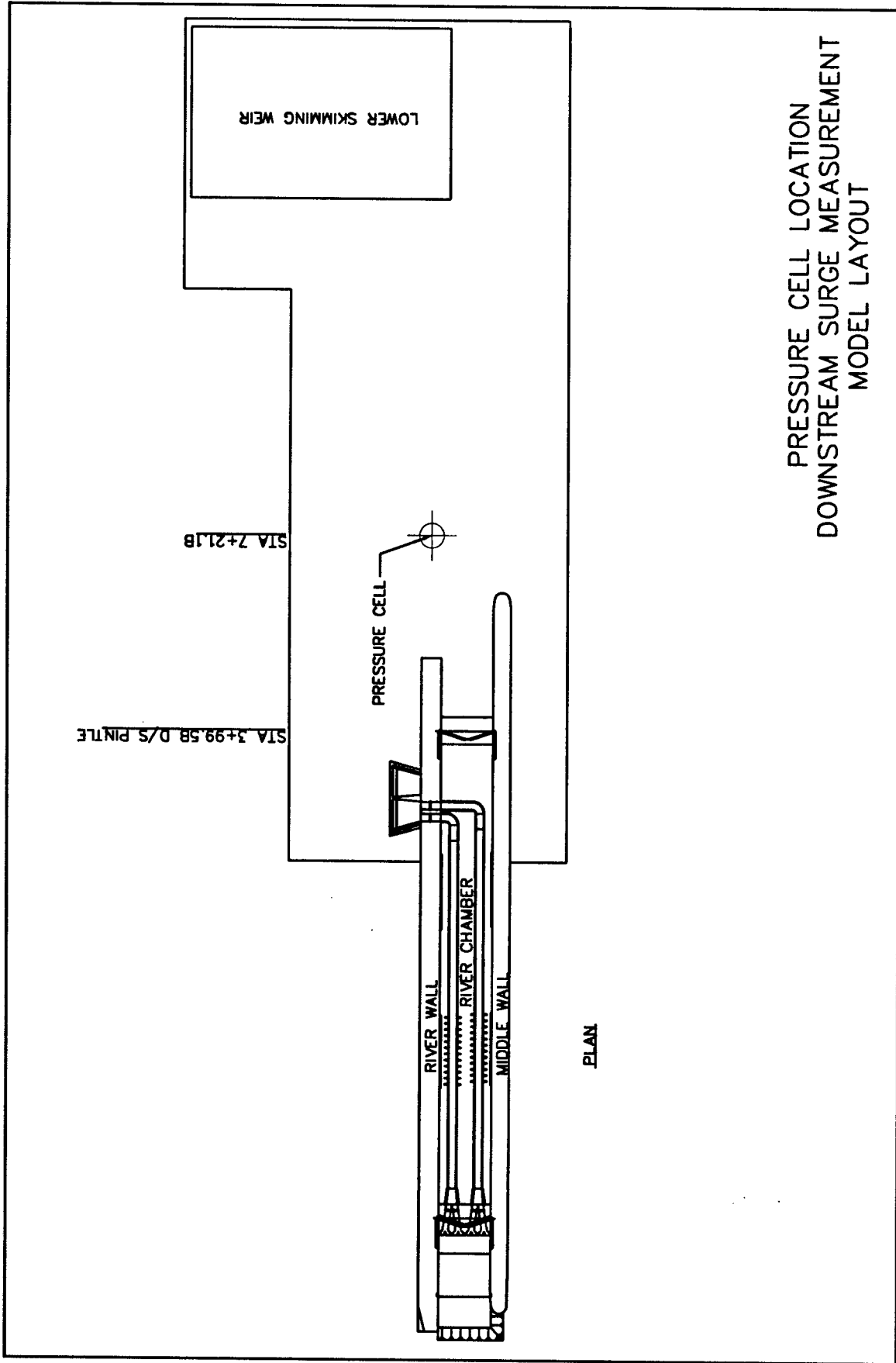

PRESSURE CELL LOCATION
 DOWNSTREAM SURGE MEASUREMENT
 MODEL LAYOUT

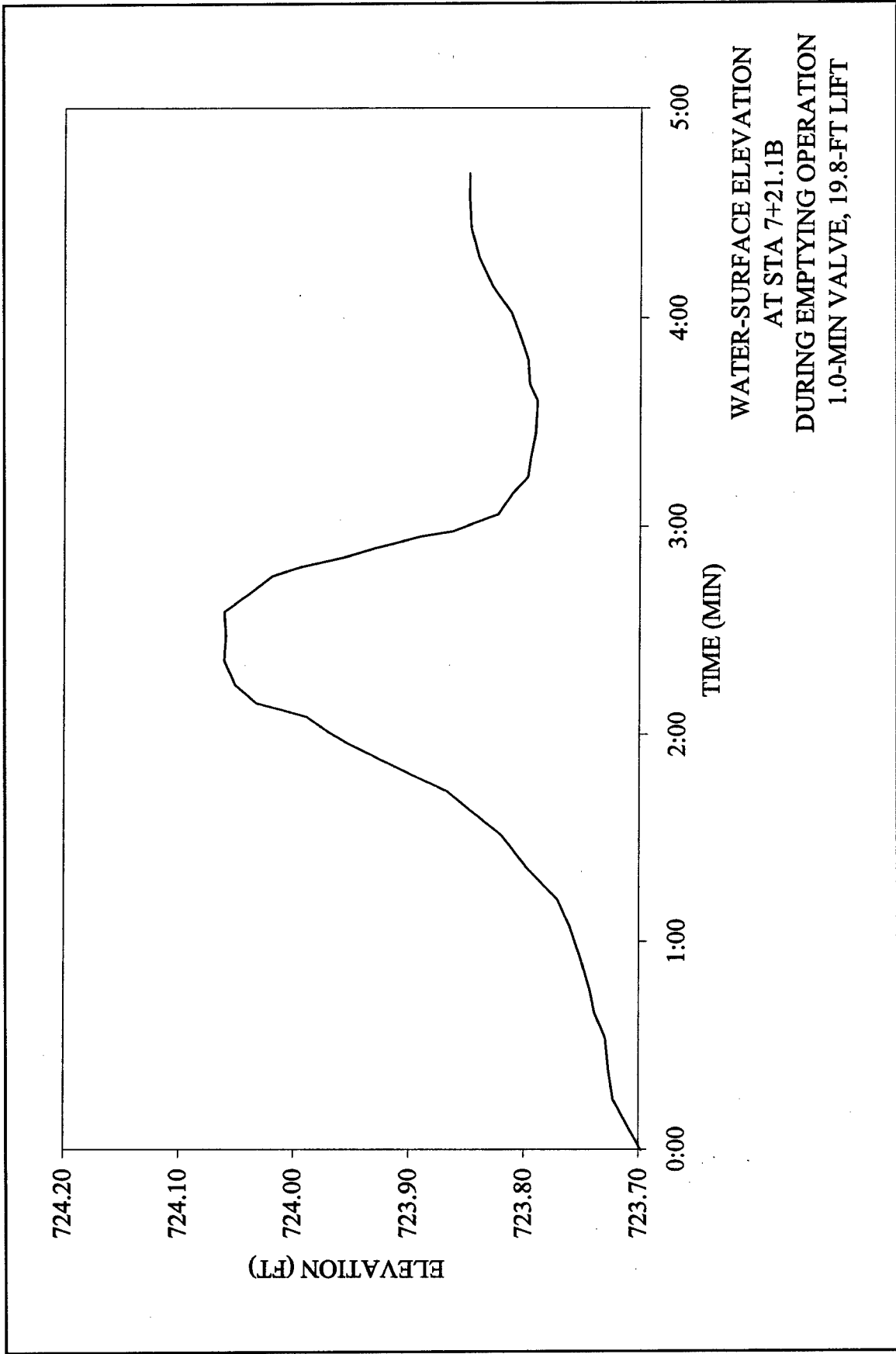

REPORT DOCUMENTATION PAGE

Form Approved
OMB No. 0704-0188

Public reporting burden for this collection of information is estimated to average 1 hour per response, including the time for reviewing instructions, searching existing data sources, gathering and maintaining the data needed, and completing and reviewing this collection of information. Send comments regarding this burden estimate or any other aspect of this collection of information, including suggestions for reducing this burden to Department of Defense, Washington Headquarters Services, Directorate for Information Operations and Reports (0704-0188), 1215 Jefferson Davis Highway, Suite 1204, Arlington, VA 22202-4302. Respondents should be aware that notwithstanding any other provision of law, no person shall be subject to any penalty for failing to comply with a collection of information if it does not display a currently valid OMB control number. **PLEASE DO NOT RETURN YOUR FORM TO THE ABOVE ADDRESS.**

1. REPORT DATE (DD-MM-YYYY) August 2003	2. REPORT TYPE Final report	3. DATES COVERED (From - To)
---	---------------------------------------	-------------------------------------

4. TITLE AND SUBTITLE Model Study of Monongahela Dam #4 Lock Replacements, Monongahela River, Pittsburgh, Pennsylvania Hydraulic Model Investigation	5a. CONTRACT NUMBER
	5b. GRANT NUMBER
	5c. PROGRAM ELEMENT NUMBER

6. AUTHOR(S) Jose E. Sanchez	5d. PROJECT NUMBER
	5e. TASK NUMBER
	5f. WORK UNIT NUMBER

7. PERFORMING ORGANIZATION NAME(S) AND ADDRESS(ES) U.S. Army Engineer Research and Development Center Coastal and Hydraulics Laboratory 3909 Halls Ferry Road Vicksburg, MS 39180-6199	8. PERFORMING ORGANIZATION REPORT NUMBER ERDC/CHL TR-03-7
---	---

9. SPONSORING / MONITORING AGENCY NAME(S) AND ADDRESS(ES) U.S. Army Engineer District, Pittsburgh 1000 Liberty Avenue Pittsburgh, PA 15222-4186	10. SPONSOR/MONITOR'S ACRONYM(S)
	11. SPONSOR/MONITOR'S REPORT NUMBER(S)

12. DISTRIBUTION / AVAILABILITY STATEMENT

Approved for public release; distribution is unlimited.

13. SUPPLEMENTARY NOTES

14. ABSTRACT

Navigation improvements are being investigated for several existing projects on the Monongahela River. A hydraulic model study was conducted to evaluate filling and emptying system design alternatives and flow conditions in the upper and lower approaches for the lock replacements at Locks and Dam #4. A 1:25-scale model was constructed to determine the range of lock performance for both locks. The proposed filling and emptying system for the locks is an In-Chamber Longitudinal Culvert Filling and Emptying System. The filling time for acceptable chamber performance with the 6.035-m (19.8-ft) lift was 8.3 min. This filling time was achieved with a 3.0-min valve. The emptying time for the same lift was 8.75 min, and it was achieved with a valve time between 1.0 and 2.0 min. Experiments were also performed to measure the surge created in the vicinity of the proposed downstream lock approach during emptying operations. Results showed that the water-surface elevation in the lower approach increased by 0.37 ft and occurred approximately 1.5 to 3.0 min into the emptying cycle.

15. SUBJECT TERMS Hawser forces Hydraulic models	In-Chamber Longitudinal Culvert Filling & Emptying System (ILCS) Lock design	Lock replacement Locks and Dam #4 Monongahela River
---	---	---

16. SECURITY CLASSIFICATION OF:			17. LIMITATION OF ABSTRACT	18. NUMBER OF PAGES 62	19a. NAME OF RESPONSIBLE PERSON
a. REPORT UNCLASSIFIED	b. ABSTRACT UNCLASSIFIED	c. THIS PAGE UNCLASSIFIED			19b. TELEPHONE NUMBER (include area code)