

**FINAL REPORT  
SEPTEMBER 2003**

**REPORT NO. 03-16**

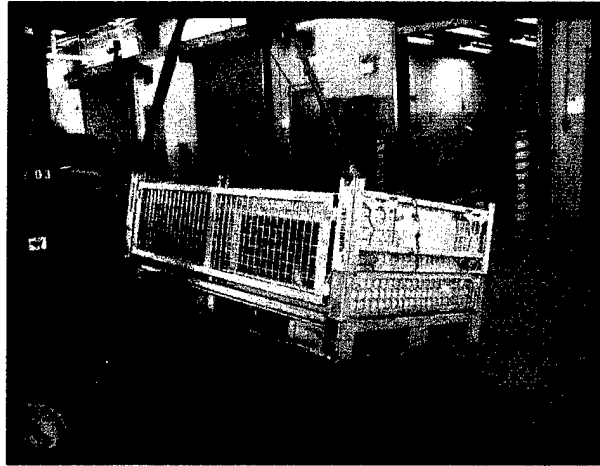

**MODULAR STORAGE AND TRANSPORT FRAME (MSTF) LOW,  
MIL-STD-1660, "DESIGN CRITERIA FOR AMMUNITION UNIT LOADS"  
TESTING**

Prepared for:

Distribution Unlimited

Mobile Shelter Systems  
4039 Ironbound Road  
Williamsburg, VA 23188



**VALIDATION ENGINEERING DIVISION  
MCALESTER, OKLAHOMA 74501-9053**

**20030930 109**

## **AVAILABILTY NOTICE**

A copy of this report will be furnished each attendee on automatic distribution. Additional copies or authority for reprinting may be obtained by written request from:

Director  
U.S. Army Defense Ammunition Center  
ATTN: SJMAC-DEV  
1 C Tree Road, Bldg. 35  
McAlester, OK 74501-9053

Reports may also be downloaded or viewed in PDF format from our web site at:

**<http://www.dac.army.mil/DEV/TestReports>**

## **DISTRIBUTION INSTRUCTIONS**

Destroy this report when no longer needed. Do not return.

\*\*\*

Citation of trade names in this report does not constitute an official endorsement.

\*\*\*

The information contained herein will not be used for advertising purposes.

**MODULAR STORAGE AND TRANSPORT FRAME (MSTF) LOW  
MIL-STD-1660, "DESIGN CRITERIA FOR AMMUNITION UNIT LOADS" TESTING****ABSTRACT**

The U.S. Army Defense Ammunition Center (DAC), Validation Engineering Division (SJMAG-DEV) was tasked by Mobile Shelter Systems, Inc. to conduct testing to determine if the Modular Storage and Transport Frame (MSTF) Low, manufactured by Mobile Shelter Systems, Inc., was adequate for unitization and transportation of boxed ammunition. The MSTF Low was evaluated by the testing procedures set forth in MIL-STD-1660. Stacking, repetitive shock, edgewise rotational drop, incline impact, sling compatibility, forklifting, and disassembly testing were conducted on the MSTF Low units.

Improvements over the previously tested MSTF Low (see DAC Report 03-05-2) include removal of excessive tolerance in the top shelf securement slot and the addition of a top shelf securement mechanism. The MSTF Low does not, however, have any means of identifying whether the top shelf is in a locked or unlocked position. This deficiency needs to be corrected in order to prevent improper shelf placement.

Following the completion of the testing of the MSTF Low units, inspection revealed bent wire mesh, cracked welds along the wire mesh and one cracked weld in the base structure. The MSTF Low remained intact and was capable of safely handling ammunition after completion of testing. The MSTF Low units with wooden dunnage successfully completed the test requirements of MIL-STD-1660.

Prepared by:

Reviewed by:

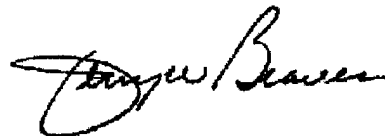
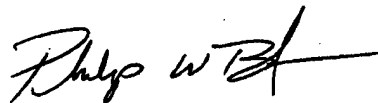

PHILIP W. BARICKMAN  
Validation Engineer

JERRY W. BEAVER  
Chief, Validation Engineering Division

**U.S. ARMY DEFENSE AMMUNITION CENTER  
VALIDATION ENGINEERING DIVISION  
MCALESTER, OK 74501-9053**

**REPORT NO. 03-16**

**MODULAR STORAGE AND TRANSPORT FRAME (MSTF) LOW,  
MIL-STD-1660, "DESIGN CRITERIA FOR AMMUNITION UNIT LOADS"  
TESTS**

**TABLE OF CONTENTS**

<b>PART</b>	<b>PAGE NO.</b>
1. INTRODUCTION .....	1-1
A. BACKGROUND .....	1-1
B. AUTHORITY .....	1-1
C. OBJECTIVE .....	1-1
D. CONCLUSION .....	1-1
2. ATTENDEES .....	2-1
3. TEST PROCEDURES .....	3-1
4. TEST EQUIPMENT .....	4-1
5. TEST RESULTS .....	5-1
6. DRAWINGS.....	6-1

## **PART 1 – INTRODUCTION**

**A. BACKGROUND.** The U.S. Army Defense Ammunition Center (DAC), Validation Engineering Division (SJMAC-DEV) was tasked by Mobile Shelter Systems, Inc. to conduct testing on the Modular Storage and Transport Frame (MSTF) Low, manufactured by Mobile Shelter Systems, Inc. The MSTF Low was evaluated by the testing procedures set forth in MIL-STD-1660. Stacking, repetitive shock, edgewise rotational drop, incline impact, sling compatibility, forklifting and disassembly testing were conducted on the MSTF Low units. The unitization procedures were provided by the DAC, Transportation Engineering Division (SJMAC-DET) (See Part 6).

**B. AUTHORITY.** This test was conducted IAW mission responsibilities delegated by the U.S. Army Joint Munitions Command (JMC), Rock Island, IL. Reference is made to the following:

1. AR 740-1, 15 June 2001, Storage and Supply Activity Operation
2. OSC-R, 10-23, Mission and Major Functions of U.S. Army Defense Ammunition Center (DAC) 21 Nov 2000.

**C. OBJECTIVE.** The objective of the testing was to determine if the MSTF Low was adequate for the unitization and transportation of boxed ammunition and could successfully pass the MIL-STD-1660 test requirements.

**D. CONCLUSION.** Improvements over the previously tested (see DAC Report 03-05-2) include removal of the excessive tolerance in the top shelf securement slot and the addition of a top shelf securement mechanism. The MSTF Low does not, however, have any means of identifying whether the top shelf position is in the locked or unlocked position. This deficiency needs to be corrected in order to prevent improper shelf placement.

Following the completion of testing of the MSTF Low units, inspection revealed bent wire mesh, cracked welds along the wire mesh, and one cracked weld in the base structure. The MSTF Low remained intact and was capable of safely handling ammunition after completion of testing. The MSTF Low units with wooden dunnage successfully completed the test requirements of MIL-STD-1660.

**PART 2 - ATTENDEES**

**ATTENDEE**

Philip W. Barickman  
General Engineer  
DSN 956-8992  
(918) 420-8992

**MAILING ADDRESS**

Director  
U.S. Army Defense Ammunition Center  
ATTN: SJMAC-DEV  
1 C Tree Road, Bldg. 35  
McAlester, OK 74501-9053

Alonza A. McWhite  
(757) 229-0059

Mobile Shelter Systems Inc.  
4039 Ironbound Road  
Williamsburg, VA 23188

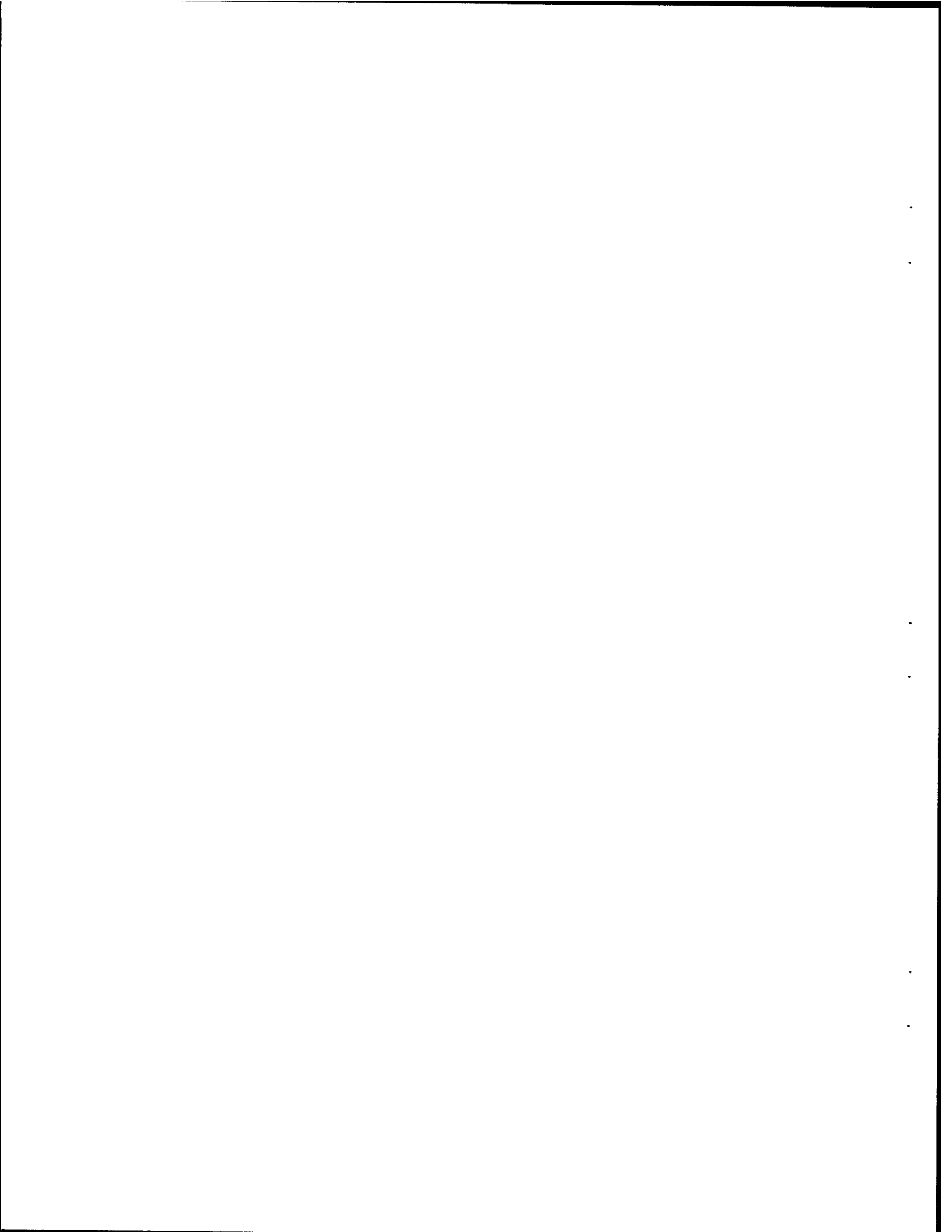

### **PART 3 - TEST PROCEDURES**

The test procedures outlined in this section were extracted from the MIL-STD-1660. The tests are conducted on ammunition pallet units or unit loads and are summarized as follows:

#### **A. MIL-STD-1660:**

**1. STACKING TEST.** The specimen will be tested to simulate a stack of identical items stacked 16 feet high, for a period of one hour. This stacking load will be simulated by subjecting the specimen to a compression weight equal to an equivalent 16-foot stacking height. Photo 1 below shows an example of a unit load in the compression tester.

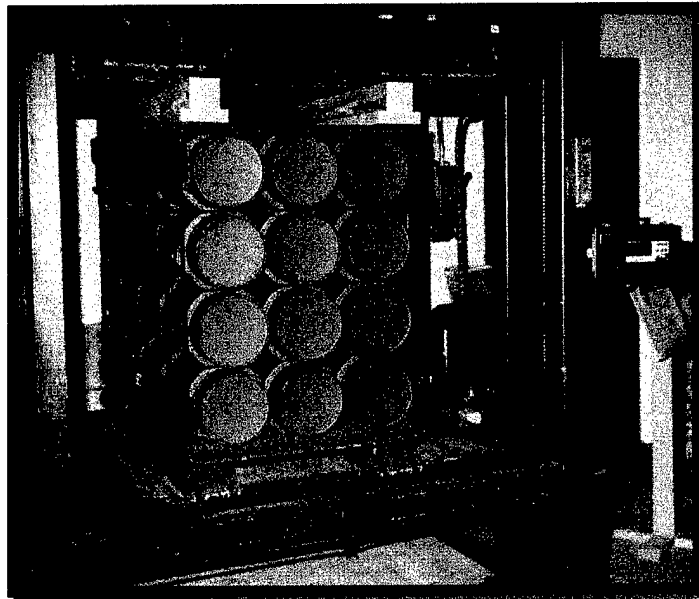

**Photo 1. Example of Stacking Test.  
(2.75-inch Hydra 70, PA151 Rocket Pallet in the Stacking Test.)**

**2. REPETITIVE SHOCK TEST.** The repetitive shock test is conducted IAW Method 5019, Federal Standard 101. The test procedure is as follows: The test specimen will be placed on (not fastened to) the platform. With the specimen in one position, the platform will be vibrated at ½-inch amplitude (1-inch double amplitude) starting at a frequency of approximately 3 cycles-per-second. The frequency will be steadily increased until the specimen leaves the platform. The resonant frequency is achieved when a 1/16-inch-thick feeler gage momentarily slides freely between every point on the specimen in contact with the platform at some instance during the cycle. Midway into the testing period, the specimen will be rotated 90 degrees, and the test continued for the duration. Unless failure occurs, the total time of vibration will be three hours. Photo 2 shows an example of the repetitive shock test.

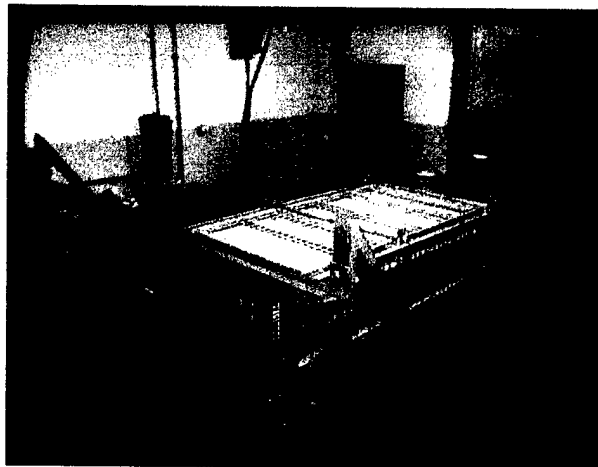

**Photo 2. Example of the Repetitive Shock Test.  
(MSTF Low)**

**3. EDGEWISE ROTATIONAL DROP TEST.** This test is conducted using the procedures of Method 5008, Federal Standard 101. The procedure for the edgewise rotational drop test is as follows: The specimen will be placed on its skids with one end of the pallet supported on a beam 6 inches high. The height of the beam will be increased as necessary to ensure that there is no support for the skids between the ends of the specimen when the dropping takes place, but

should not be high enough to cause the specimen to slide on the supports when the dropped end is raised for the drop. The unsupported end of the specimen is then raised and allowed to fall freely to the concrete, pavement, or similar unyielding surface from a prescribed height. Unless otherwise specified, the height of drop for level A protection will conform to the following tabulation:

GROSS WEIGHT (WITHIN RANGE LIMITS) (Pounds)	DIMENSIONS OF ANY EDGE, HEIGHT OR WIDTH (WITHIN RANGE LIMITS) (Inches)	HEIGHT OF DROPS ON EDGES	
		Level A (Inches)	Level B (Inches)
150-250	60-66	36	27
250-400	66-72	32	24
400-600	72-80	28	21
600-1,000	80-95	24	18
1,000-1,500	95-114	20	16
1,500-2,000	114-144	17	14
2,000-3,000	Above 145- No limited	15	12
Above – 3,000		12	9

Figure 1.



Photo 3. Example of Edgewise Rotational Drop Test (MSTF Low)

**4. INCLINE-IMPACT TEST.** This test is conducted by using the procedure of Method 5023, Incline-Impact Test of Federal Standard 101. The procedure for the incline-impact test is as follows: The specimen will be placed on the carriage with the surface or edge to be impacted projecting at least 2 inches beyond the front end of the carriage. The carriage will be brought to a predetermined position on the incline and released. If it were desired to concentrate the impact on any particular position on the container, a 4- x 4-inch timber may be attached to the bumper in the desired position before the test. The carriage will not strike any part of the timber. The position of the specimen on the carriage and the sequence in which surfaces and edges are subjected to impacts may be at the option of the testing activity and dependent upon the objective of the test. When the test is to determine satisfactory requirements for a container or pack, and, unless otherwise specified, the specimen will be subjected to one impact on each surface that has each dimension less than 9.5 feet. Unless otherwise specified, the velocity at the time of the impact will be 7 feet-per-second. Photo 4 shows an example of this test.

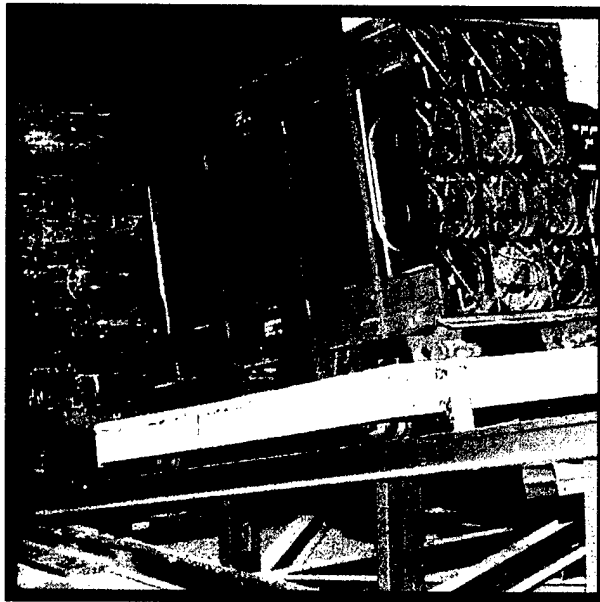

**Photo 4. Example of the Incline-Impact Test.  
(2.75-Inch, Hydra 70, PA151 Rocket Pallet on incline-impact tester.)**

**5. SLING COMPATIBILITY TEST.** The specimen utilizing special design or non-standard pallets will be lifted, swung, lowered and otherwise handled as necessary, using slings of the types normally used for handling the unit loads under consideration. Slings will be easily attached and removed. Danger of slippage or disengagement when load is suspended will be cause for rejection of the specimen.

**6. FORKLIFTING TESTS.** The specimen will be lifted clear of the ground by a forklift from the end of the specimen and transported on the forks in the level or back-tilt position. The forklift will pass over the Optional Rough Handling Course For Forklift Trucks as outlined in MIL-STD-1660. The course will consist of parallel pairs of 1-inch boards spaced 54 inches apart and will be laid flat wise on the pavement across the path of the forklift. One pair will be laid at an angle of approximately 60 degrees to the path so that the left wheel strikes first. Another pair will be laid securely across the path of the forklift so that the wheels strike simultaneously. Another pair will be laid at an angle of approximately 75 degrees to the path so that the right wheel strikes first. The specimen will be transported through the Optional Rough Handling Course. The specimen shall be observed for deflection and damage. The specimen will be rotated 90 degrees and the specimen lifted from the side and the above steps repeated.

**7. DISASSEMBLY TEST.** Following all rough handling tests the specimen may be squared up within 2 inches of its original shape and on a flat level surface. The strapping will then be cut and removed from the palletized load. Assembly of the specimen will be such that it retains its unity upon removal of the strapping.

## **PART 4 - TEST EQUIPMENT**

### **A. COMPRESSION TESTER.**

- |                       |                      |
|-----------------------|----------------------|
| 1. Manufacturer:      | Ormond Manufacturing |
| 2. Platform:          | 60- x 60-inches      |
| 3. Compression Limit: | 50,000 pounds        |
| 4. Tension Limit:     | 50,000 pounds        |

### **B. TRANSPORTATION SIMULATOR.**

- |                  |                     |
|------------------|---------------------|
| 1. Manufacturer: | Gaynes Laboratory   |
| 2. Capacity:     | 6,000-pound payload |
| 3. Displacement: | 1/2-inch amplitude  |
| 4. Speed:        | 50 to 400 RPM       |
| 5. Platform:     | 5- x 8-foot         |

### **C. INCLINED PLANE.**

- |                  |                    |
|------------------|--------------------|
| 1. Manufacturer: | Conbur Incline     |
| 2. Type:         | Impact Tester      |
| 3. Grade:        | 10 percent incline |
| 4. Length:       | 12-foot            |

## **PART 5 - TEST RESULTS**

**5.1. FRAME DATA.** The MSTF Low Test Unit #1 was inertly loaded to the specified design weight using inert simulation in wooden boxes and wooden dunnage. The test specimen was prepared using the unitization procedures specified in Part 6 – Drawings. Special care was taken to ensure that each C445 wooden box had the proper amount of weight in order to achieve a realistic pallet center of gravity (CG). Once properly prepared, the MSTF Low Test Unit #1 was tested using the MIL-STD-1660 requirements.

### **MODULAR STORAGE AND TRANSPORT FRAME (MSTF) LOW.**

#### **TEST UNIT #1 WITH WOODEN DUNNAGE**

Date: 21 July 2003  
Gross Weight: 2420 pounds  
Length: 82 inches  
Width: 45 ½ inches  
Height: 32 1/2 inches  
Mfg: Mobile Shelter Systems, Inc.

#### **A. MODULAR STORAGE AND TRANSPORT FRAME (MSTF) LOW, TEST UNIT #1 WITH WOODEN DUNNAGE- TEST RESULTS:**

**1. STACKING TEST.** The test specimen was compressed with a load force of 12,100 pounds for 60 minutes on 21 July 2003. No damage was noted as a result of this test. See Photo 5 of the test specimen in the compression unit.



**Photo 5. MSTF Low Test Unit #1 With Wooden Dunnage  
in the Compression Tester.**

**2. REPETITIVE SHOCK TEST.** The specimen was vibrated 90 minutes at 239 RPM in the lateral orientation and 90 minutes at 245 RPM in the longitudinal orientation. No damage was noted as a result of this test. Photo 6 shows the specimen on the vibration platform.

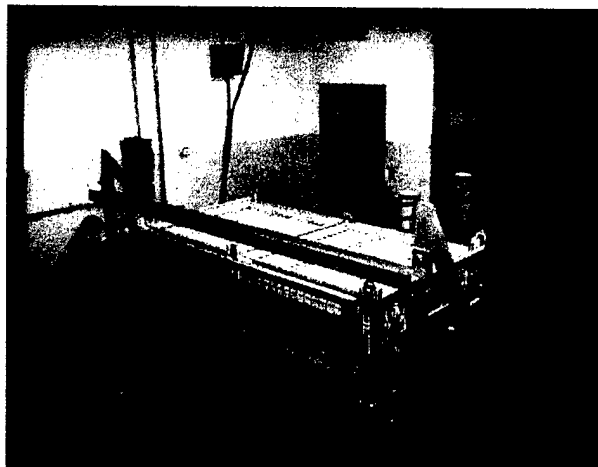

**Photo 6. MSTF Low Test Unit #1 With Wooden Dunnage  
During Repetitive Shock Testing.**

3. **EDGEWISE ROTATIONAL DROP TEST.** The specimen was edgewise rotationally dropped from a height of 15 inches on both longitudinal sides and both lateral sides. Photo 7 shows the specimen during the drop test.

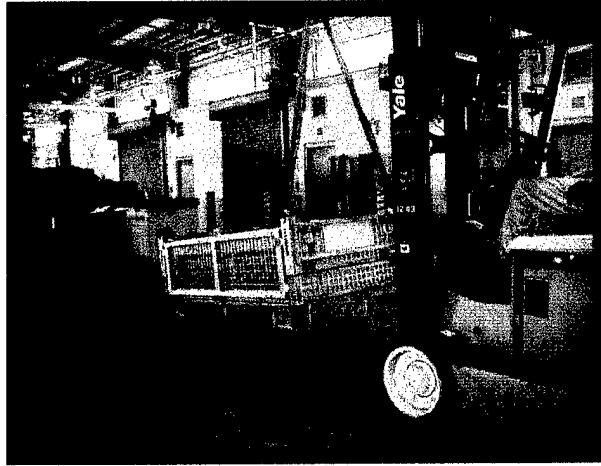

**Photo 7. Edgewise Rotational Drop Test on the MSTF Low Test Unit #1 With Wooden Dunnage.**

4. **INCLINE-IMPACT TEST.** The specimen was impact tested on both longitudinal sides and both lateral sides. No significant damage was noted as a result of this test to the MSTF Low Test Unit #1. Damage occurred to the dunnage during the fourth impact. See Photo 8 for the specimen during the lateral incline-impact test.

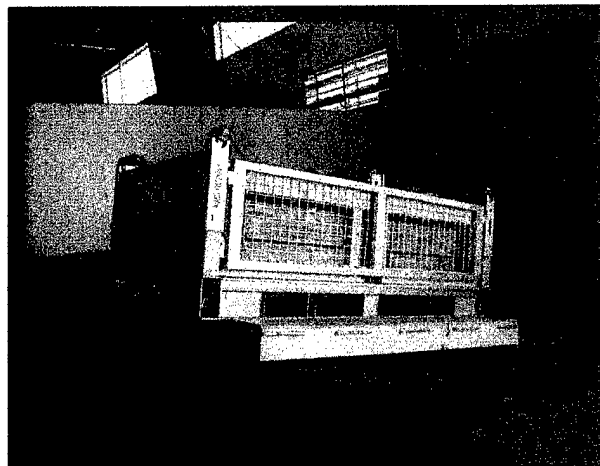

**Photo 8. Incline-Impact Testing of the MSTF Low Test Unit #1 with Wooden Dunnage**

5. **SLING COMPATIBILITY TEST.** During testing the specimen was lifted, swung, lowered and handled as necessary using slings of the types normally used for handling the unit loads. The compatibility testing was conducted using a two-point lift, a three-point lift and a four-point lift. Photo 9 shows the specimen during the sling compatibility test. No damage was noted as a result of this test. The slings were easily attached and removed.

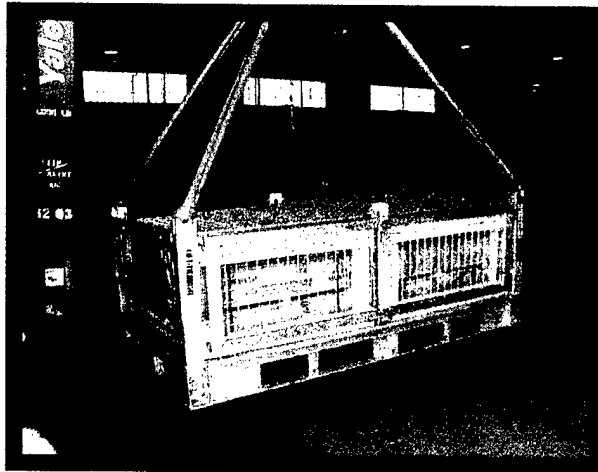

**Photo 9. MSTF Low Test Unit #1 with Wooden Dunnage  
During the Sling Compatibility Test**

6. **FORKLIFTING TEST.** The specimen was lifted clear of the ground by a forklift from both longitudinal sides and both lateral sides and transported. Photo 10 shows the specimen during the Forklifting Test. No damage was noted as a result of this test.



**Photo 10. MSTF Low Test Unit #1 With Wooden Dunnage  
During the Forklifting Test**

**7. DISASSEMBLY TEST.** Inspection revealed bent wire mesh, cracked welds along the wire mesh and one cracked weld in the base structure. The specimen maintained adequate integrity and was still considered safe to handle.

**8. CONCLUSION.** As tested, the Modular Storage and Transport Frame (MSTF) Low Test Unit #1, with wooden dunnage, manufactured by Mobile Shelter Systems, successfully completed the MIL-STD-1660 test requirements.

**5.2. FRAME DATA.** The MSTF Low Test Unit #2 was inertly loaded to the specified design weight using inert simulation in wooden boxes and wooden dunnage. The test specimen was prepared using the unitization procedures specified in Part 6 – Drawings. Special care was taken to ensure that each C445 wooden box had the proper amount of weight in order to achieve a realistic pallet center of gravity (CG). Once properly prepared, the MSTF Low Test Unit #2 was tested using the MIL-STD-1660 requirements.

**MODULAR STORAGE AND TRANSPORT FRAME (MSTF) LOW,  
TEST UNIT #2 WITH WOODEN DUNNAGE**

Date: 22 July 2003  
Gross Weight: 2425 pounds  
Length: 82 inches  
Width: 45 ½ inches  
Height: 32 1/2 inches  
Mfg: Mobile Shelter Systems, Inc.

**A. MODULAR STORAGE AND TRANSPORT FRAME (MSTF) LOW,  
TEST UNIT 2 WITH WOODEN DUNNAGE- TEST RESULTS:**

**1. STACKING TEST.** The test specimen was compressed with a Lload force of 12,125 pounds for 60 minutes on 22 July 2003. No damage was noted as a result of this test. See Photo 11 of the test specimen in the compression unit.

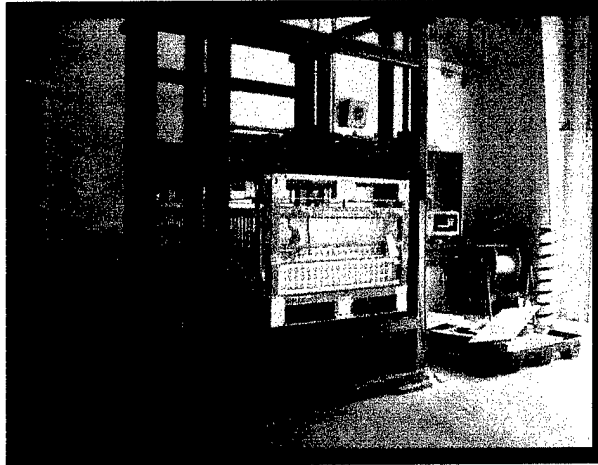

**Photo 11. MSTF Low Test Unit #2 With Wooden Dunnage in the Compression Tester.**

2. **REPETITIVE SHOCK TEST.** The specimen was vibrated 90 minutes at 250 RPM in the longitudinal orientation and 90 minutes at 229 RPM in the lateral orientation. No significant damage was noted to the MSTF Low as a result of this test. One latch on the wooden payload box broke during testing. Photo 12 shows the specimen on the vibration platform.

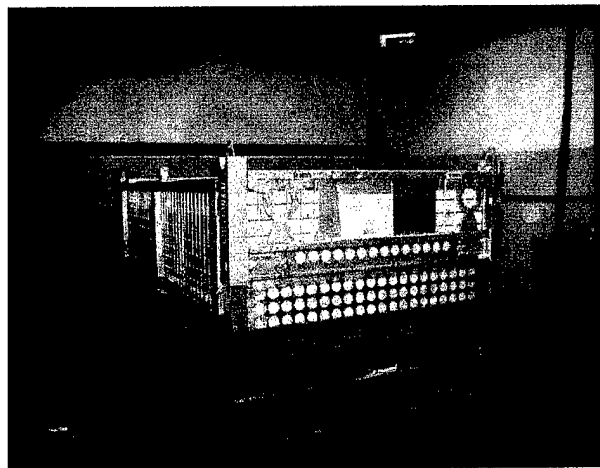

**Photo 12. MSTF Low Test Unit #2 With Wooden Dunnage During Repetitive Shock Testing.**

**3. EDGEWISE ROTATIONAL DROP TEST.** The specimen was edgewise rotationally dropped from a height of 15 inches on both longitudinal sides and both lateral sides. No damage was noted as a result of this test. Photo 13 shows the specimen during the drop test.

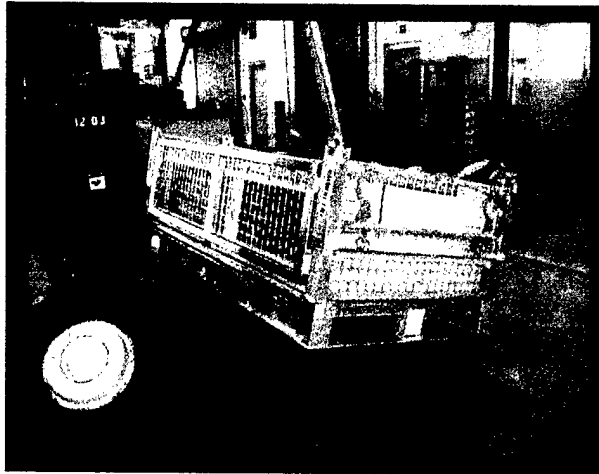

**Photo 13. Edgewise Rotational Drop Test on the MSTF Low Test Unit #2 with Wooden Dunnage.**

**4. INCLINE-IMPACT TEST.** The specimen was impact tested on both longitudinal sides and both lateral sides. No damage was noted as a result of this test. See Photo 14 for the specimen during the lateral incline-impact test.

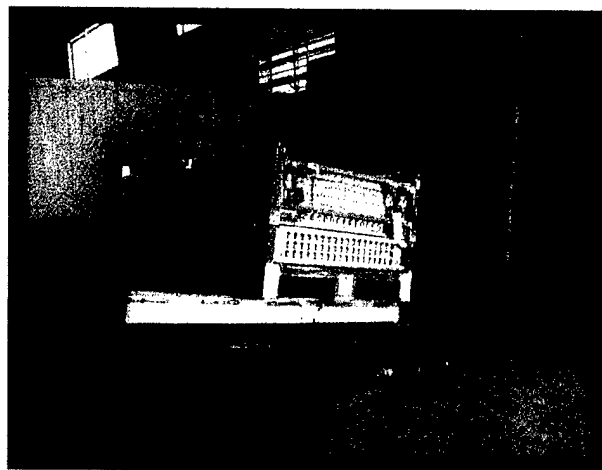

**Photo 14. Incline-Impact Testing of the MSTF Low Test Unit #2 With Wooden Dunnage**

5. **SLING COMPATIBILITY TEST.** During testing the specimen was lifted, swung, lowered and handled as necessary using slings of the types normally used for handling the unit loads. The compatibility testing was conducted using a two-point lift, a three-point lift, and a four-point lift. No damage was noted as a result of this test. The slings were easily attached and removed. Photo 15 shows the specimen during the sling compatibility test.

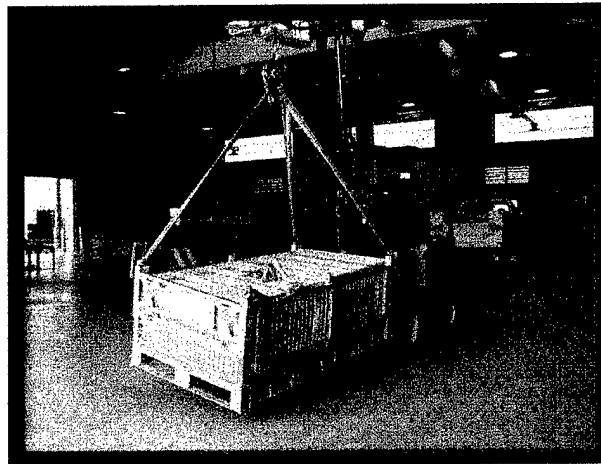

**Photo 15. MSTF Low Test Unit #2 With Wooden Dunnage  
Sling Compatibility Testing.**

6. **FORKLIFTING TEST.** The specimen was lifted clear of the ground by a forklift from both longitudinal sides and both lateral sides and transported. No damage was noted as a result of this test. Photo 16 shows the specimen during the Forklifting Test. .

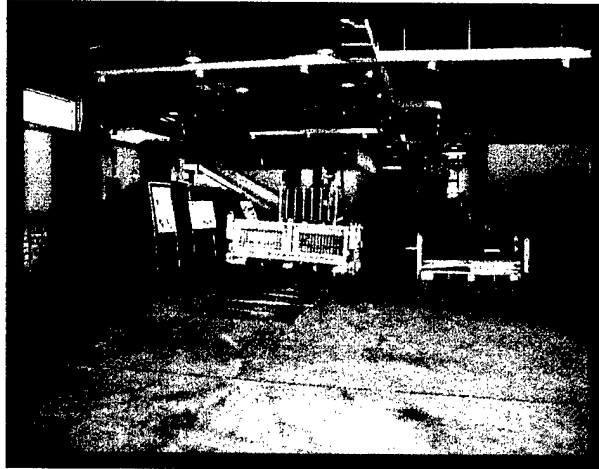

**Photo 16. MSTF Low Test Unit #2 With Wooden Dunnage  
During the Forklifting Test**

7. **DISASSEMBLY TEST.** Inspection revealed bent wire mesh, cracked welds along the wire mesh and one cracked weld in the base structure. The specimen maintained adequate integrity and was still considered safe to handle.

8. **CONCLUSION.** As tested, the Modular Storage and Transport Frame (MSTF) Low Test Unit #2, with wooden dunnage, manufactured by Mobile Shelter Systems, successfully completed the MIL-STD-1660 test requirements.

## **PART 6 – DRAWINGS**

The following drawing represents the load configuration that was subjected to the test criteria.

# **MIL-STD-1660 TESTING OF THE MODULAR - TRANSPORT STORAGE FRAME (M-STF) LOAD SKETCH**

**THIS THREE PAGE DOCUMENT DEPICTS PROCEDURES FOR UNITIZING  
THE TEST LOAD FROM THE M-STF MIL-STD 1660 TESTING.**

**OVERALL DIMENSIONS OF THE M-STF:  
81-3/4"L X 45-1/4"W X 33"H**

**Prepared during June 2003 by:  
U.S. Army Defense Ammunition Center  
ATTN: SJMAC-DET  
McAlester, OK 74501  
POC: Mike Bartosiak  
DSN 956-8083  
Comm (918) 420-8083  
Fax 956-8811  
E-mail: michael.bartosiak@dac.army.mil**

**Laura Fieffer  
Acting Chief, Transportation Engineering Division**

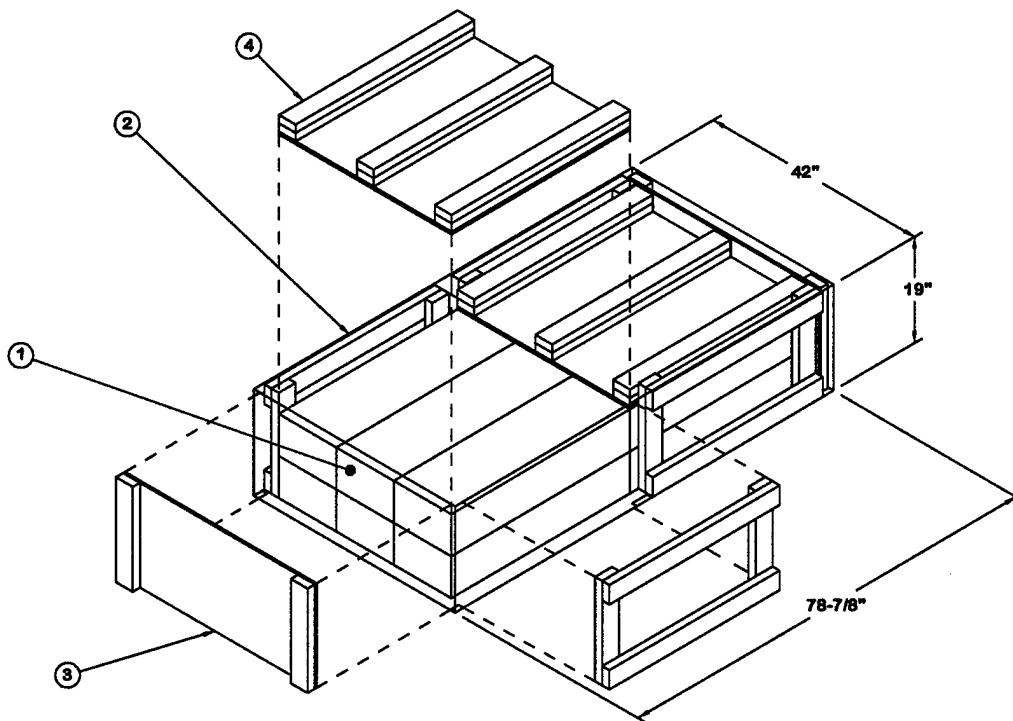

\* M-STF INTERIOR DIMENSIONS SHOWN ONLY.  
M-STF WAS NOT SHOWN FOR CLARITY.

**M-STF UNIT LOAD**

12 BOXES OF 105MM HOWITZER AT (155 LBS) - - - - -	1,860 LBS (APPROX)
DUNNAGE - - - - -	135 LBS (APPROX)
M-STF - - - - -	460 LBS
<hr/>	
TOTAL WEIGHT - - - - -	2,455 LBS (APPROX)
CUBE - - - - -	70.7 CU FT (APPROX)

**NUMBERED ITEMS**

- ① 37-1/4" L X 12" W X 7-1/2" H, 105MM WOOD BOXES, WEIGHTED AT 155 LBS EACH, LOADED AS SHOWN (12 REQD).
- ② FRONT/REAR DUNNAGE ASSEMBLY, SEE DETAIL ON PAGE 3 (4 REQD).
- ③ SIDE DUNNAGE ASSEMBLY, SEE DETAIL ON PAGE 3 (2 REQD).
- ④ TOP DUNNAGE ASSEMBLY, SEE DETAIL ON PAGE 3 (2 REQD).

**BILL OF MATERIAL**

LUMBER	LINEAR FEET	BOARD FEET
1" X 4"	18.5	6.2
2" X 4"	60.8	40.5
NAILS	NO. REQD	POUNDS
6d (2")	48	.28
10d (3")	54	.89
M-STF - - - - -	1 REQD - - - - -	460 LBS
1/2 PLYWOOD - - - - -	28.9 SQ FT - - - - -	39.74 LBS

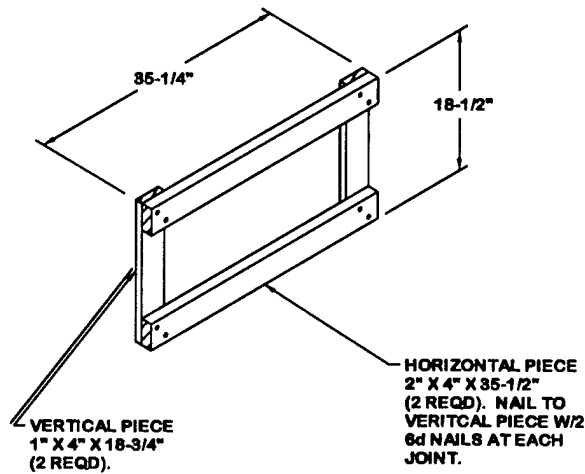

**FRONT/REAR DUNNAGE ASSEMBLY**  
(4 REQD)

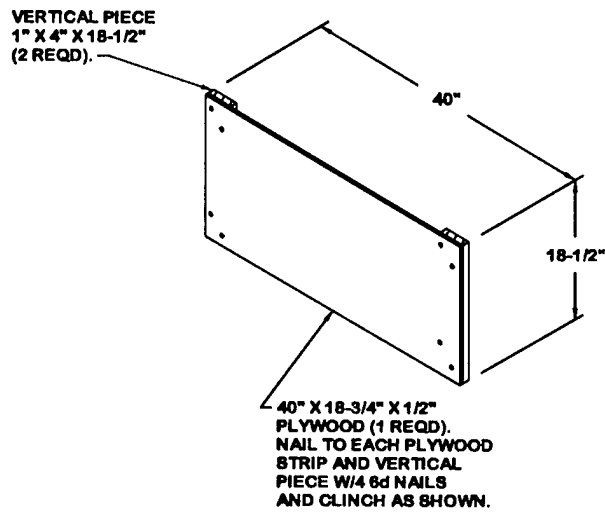

**SIDE DUNNAGE ASSEMBLY**  
(2 REQD)

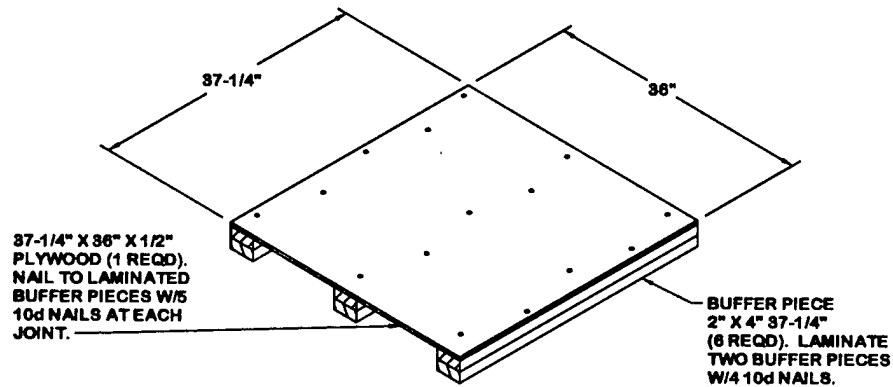

**TOP DUNNAGE ASSEMBLY**  
(2 REQD)