

**PLANNING AND IMPLEMENTATION OF NON-POTABLE  
WATER REUSE PROJECTS AT U.S. NAVAL INSTALLATIONS**

by

**Joshua Benjamin Malkin**  
Lieutenant, Civil Engineer Corps, U.S. Navy

Scholarly Paper submitted in partial fulfillment of the requirements for the degree of  
Master of Science in Civil Engineering  
August 2003

Advisor: Alba Torrents, PhD, Associate Professor  
Department of Civil and Environmental Engineering  
University of Maryland, College Park

**DISTRIBUTION STATEMENT A**  
Approved for Public Release  
Distribution Unlimited

20030929 115

## **ABSTRACT**

Title of Paper: PLANNING AND IMPLEMENTATION OF NON-POTABLE  
WATER REUSE PROJECTS AT U.S. NAVAL  
INSTALLATIONS

Name of Degree Candidate: Joshua Benjamin Malkin

Degree and Year: Master of Science in Civil Engineering, 2003

Advisor: Alba Torrents, PhD, Associate Professor

With the passage of Executive Orders 12902 and 13123, the U.S. Navy has been forced to develop water conservation programs and evaluate how water is used at each of its installations. The central goal of these orders is to reduce potable water consumption at federal facilities. Water reuse and recycling has been listed as a best management practice for achieving this goal. However, only a handful of Navy facilities have implemented water reuse projects to date. One of the reasons for this phenomenon is the lack of comprehensive guidance for planning and executing water reuse projects. Consequently, very few Navy facility and energy managers have experience or knowledge regarding water reuse applications. This paper addresses the key factors that must be considered when attempting to execute water reuse projects on Navy installations. Specifically, the following areas are examined: (1) scope and requirements of the U.S. Navy Water Conservation Program, (2) Federal, state, and local regulations, guidance, and other legal issues relating to water reuse, (3) treatment processes used to remove contaminants in order to meet process or regulatory requirements, (4) potential water reuse applications, (5) water storage, (6) risk management, (7) economic considerations, and (8) the project implementation process. Finally, a case study of the U.S. Naval Construction

Battalion Center, Gulfport, MS that evaluates various options for water reuse is included at the end of the paper.

This paper is intended to establish baseline guidance for planning and implementing water reuse projects at Navy installations. However, site-specific requirements must be considered when planning individual projects. Each base and community will view water reuse differently. The availability of water, public perceptions, intended applications, funding availability, and a host of other issues will determine a water reuse project's success. It is up to facility managers to balance technical requirements, benefits, risks, and local concerns in the planning process.

## TABLE OF CONTENTS

	<i>Page</i>
1. Background and Introduction	1
1.1. Purpose and Scope	1
1.2. The Need for Water Reuse	4
2. U.S. Navy Water Conservation Program	7
2.1. Executive Order 12902	7
2.2. Executive Order 13123	9
3. Legal Issues	11
3.1. Federal Environmental Regulations	11
3.1.1. National Environmental Policy Act	12
3.1.2. Clean Water Act	14
3.1.3. Safe Drinking Water Act	16
3.2. State Level Water Reuse Regulations	17
3.3. EPA Recommended Guidelines for Water Reuse	20
3.4. Water Rights	21
4. Water Treatment Processes	23
4.1. Preliminary Treatment	23
4.1.1. Screening	24
4.1.2. Comminution	24
4.1.3. Grit Removal	25
4.1.4. Flow Equalization	25
4.2. Primary Treatment	26
4.3. Secondary Treatment	28
4.3.1. Aerobic Biological Treatment	28
4.3.1.1. High-Rate Processes	28
4.3.1.1.1. Activated Sludge	29
4.3.1.1.2. Trickling Filters	29
4.3.1.1.3. Rotating Biological Contactors	30
4.3.1.2. Low-Rate Processes	31
4.3.1.2.1. Aerated Lagoons	31
4.3.1.2.2. Stabilization Ponds	32
4.3.2. Secondary Sedimentation	33
4.4. Advanced Treatment	34
4.4.1. Disinfection	34
4.4.2. Nitrification	38
4.4.3. Denitrification	39

4.4.4. Filtration	40
4.4.5. Phosphorous Removal	43
4.4.6. Coagulation/Flocculation/Sedimentation	46
4.4.7. Activated Carbon Adsorption	48
4.4.8. Ion Exchange	50
4.4.9. Ammonia Stripping	51
4.4.10. Membrane Processes	52
4.5. Land Applications	55
4.5.1. Land Treatment	55
4.5.1.1. Slow Rate (SR)	55
4.5.1.2. Rapid Infiltration (RI)	56
4.5.1.3. Overland Flow (OF)	56
4.5.2. Constructed Wetlands	57
5. Industrial Uses	59
5.1. Vehicle and Aircraft Washing Facilities	59
5.1.1. Water Quality Requirements	60
5.1.2. Potential Water Sources	61
5.1.3. Treatment	62
5.1.3.1. Secondary Effluent Reuse	62
5.1.3.2. On-Site Reclamation	63
5.1.3.2.1. Intermittent Sand Filtration	63
5.1.3.2.2. Lagoons	65
5.1.3.2.3. Constructed Wetlands	66
5.1.3.3. Cooling Tower Blowdown Reuse	67
5.2. Plating Operations	67
5.2.1. Water Quality Requirements	68
5.2.2. Reuse Alternatives	68
5.2.2.1. Recycling	68
5.2.2.2. Reclamation	69
5.3. Metal Cleaning Facilities	69
5.3.1. Water Quality Requirements	70
5.3.2. Reuse Alternatives	70
5.4. Industrial Laundry Facilities	71
5.4.1. Water Quality Requirements	71
5.4.2. Reuse Alternatives	72
5.5. Cooling Systems	73
5.5.1. Water Quality Requirements	74
5.5.2. Potential Water Sources	75
5.5.3. Treatment Requirements	75
5.5.3.1. Scaling	75
5.5.3.2. Corrosion	76
5.5.3.3. Biological Growth	76
5.5.3.4. Fouling	77

6. Irrigation	78
6.1. Golf Course Irrigation	79
6.1.1. Water Quality	79
6.1.1.1. EPA Recommended Standards	79
6.1.1.2. Potential Quality Problems	81
6.1.1.2.1. Salinity	81
6.1.1.2.2. Sodium	83
6.1.1.2.3. Toxic Elements	83
6.1.1.2.4. Bicarbonate	84
6.1.1.2.5. pH	84
6.1.1.2.6. Nutrients	84
6.1.2. Water Treatment Requirements	85
6.1.2.1. Salinity	85
6.1.2.2. Sodium	86
6.1.2.3. Toxic Elements	86
6.1.2.4. Bicarbonate	86
6.1.2.5. pH	86
6.1.2.6. Nutrients	87
6.1.3. System Design Requirements	87
6.1.3.1. Water Distribution System	87
6.1.3.2. Pressure and Flow Requirements	88
6.1.3.3. Identification of Piping and Appurtenances	88
6.1.3.4. Separation of Potable and Non-Potable Piping	89
6.1.3.5. Site Characteristics	90
6.1.3.5.1. Topography	90
6.1.3.5.2. Soils	90
6.1.3.5.3. Groundwater	91
6.1.3.5.4. Climate	91
6.1.3.6. Backflow Prevention	91
6.2. Other Non-Agricultural Irrigation	92
6.3. Residential Lawn Irrigation	92
6.3.1. System Design	93
6.3.1.1. Greywater Collection, Storage, and Distribution	93
6.3.1.2. Irrigation Methods	94
6.3.2. Treatment Requirements	95
7. Toilet and Urinal Flushing	96
7.1. System Design	97
7.2. Treatment	97
8. Water Storage Facilities	98
8.1. Open Reservoirs	99
8.2. Enclosed Storage	100

9. Risk Management	101
9.1. Risk Assessment	101
9.1.1. Release Assessment	102
9.1.1.1. Contaminant Identification	103
9.1.1.2. Contaminant Quantities and Probability of Release	104
9.1.1.3. Rate of Release	106
9.1.2. Transport Assessment	106
9.1.3. Exposure Assessment	107
9.1.4. Consequence Assessment	109
9.2. Cost	111
9.3. Public Opinion	112
10. Economic Considerations	115
10.1. Benefits	115
10.2. Reliability	116
10.3. Timing	116
10.4. Optimization	117
11. Implementing Water Reuse Projects	118
11.1. Submittals	118
11.2. Funding	123
11.3. Base-wide Education	124
11.4. Monitoring Results	124
12. Case Study: Naval Construction Battalion Center, Gulfport, MS	125
12.1. Installation Overview	126
12.2. Local Water Treatment Facilities	127
12.3. Proposed Water Reuse Applications	129
12.3.1. Golf Course Irrigation	131
12.3.2. Recreational Field Irrigation	134
12.3.3. Vehicle Washracks	135
13. Conclusions and Recommendations	138

## LIST OF FIGURES

- Figure 1 - Typical Water Uses at a U.S. Naval Installation
- Figure 2 - Residential Usage
- Figure 3 - Office Usage
- Figure 4 - Organizational Roles for Water Conservation
- Figure 5 - Individual State Water Reuse Guidelines and Regulations
- Figure 6 - Equalization Basin
- Figure 7 - Primary Clarifier
- Figure 8 - Standard Trickling Filter Configurations
- Figure 9 - Rotating Biological Contactor
- Figure 10 - Chlorine Contact Basin
- Figure 11 - Ozonation Process Diagram
- Figure 12 - Examples of UV Radiation Systems
- Figure 13 - Contaminant Removal Efficiencies for Filtration of Secondary Biological Effluent
- Figure 14 - Mounded Filter
- Figure 15 - Slow-Sand Filter
- Figure 16 - Removal Efficiencies for Various Coagulants
- Figure 17 - Typical Ion Exchanger
- Figure 18 - Ammonia Stripping Process
- Figure 19 - Reverse Osmosis Unit
- Figure 20 - Electrodialysis Process
- Figure 21 - Average Water Quality from Land Treatment of Municipal Wastewater
- Figure 22 - Typical Characteristics of Vehicle and Aircraft Washing Facilities
- Figure 23 - Recommended Water Quality Standards for Vehicle and Aircraft Washing Facilities
- Figure 24 - Process Diagram for Intermittent Sand Filtration
- Figure 25 - Typical Intermittent Sand Filter System
- Figure 25 - Process Diagram for Lagoon Washwater Treatment System
- Figure 26 - Process Diagram for Constructed Wetland Treatment System
- Figure 27 - Water Quality Requirements for Plating Rinse Water
- Figure 28 - Water Quality Requirements for Metal Cleaning Rinse Water
- Figure 29 - Water Quality Requirements for Industrial Laundry Facilities
- Figure 30 - Typical Cooling Tower
- Figure 31 - Water Quality Requirements for Cooling Towers
- Figure 32 - Recommended Water Quality Requirements for Unrestricted Urban Reuse
- Figure 33 - Recommended Limits for Inorganic Constituents in Reclaimed Irrigation Water
- Figure 34 - Salinity Tolerance Levels of Various Turf Grasses
- Figure 35 - Typical Water Reclamation Advisory Signs
- Figure 36 - Typical Greywater Irrigation System
- Figure 37 - Characteristics of Untreated Greywater and Domestic Wastewater
- Figure 38 - Water Conservation Project Programming Process
- Figure 39 - Organizational Responsibilities in the Water Conservation Project Submittal Process

- Figure 40 - Mississippi Precipitation Statistics: 1993 to Present  
Figure 41 - Aerial Photo of NCBC Gulfport, MS  
Figure 41 - Aerial Photo of NCBC Gulfport, MS  
Figure 42 - Aerial Photo of Gulfport South WWTP  
Figure 43 - Typical Water Quality at Gulfport South WWTP  
Figure 44 - Comparison of Water Quality at Gulfport South WWTP to EPA Recommended Standards for Unrestricted Urban Reuse  
Figure 45 - Comparison of Water Quality at Gulfport South WWTP, EPA Recommended Standards for Unrestricted Urban Reuse, and Washrack Requirements

## **APPENDICES**

- Appendix I - Glossary  
Appendix II - EPA Recommended Guidelines for Water Reuse  
Appendix III - Irrigation System for the Front Nine Holes at Pine Bayou Golf Course, NCBC Gulfport, MS  
Appendix IV - Irrigation System for the Back Nine Holes at Pine Bayou Golf Course, NCBC Gulfport, MS  
Appendix V - References

# **1. BACKGROUND AND INTRODUCTION**

## **1.1. PURPOSE AND SCOPE**

For many years, potable water has been considered a renewable resource. It is cheap and abundant in many areas of the U.S., and most people take for granted that it will flow freely every time they turn on the tap. In the past 30 years, however, the Federal Government has taken a closer look at water use and conservation practices. Passage of environmental legislation such as the National Environmental Policy Act, Clean Water Act, and Safe Drinking Water Act have forced public and private agencies alike to reconsider how they use and dispose of water. More recently, President William J. Clinton signed Executive Order 12902, followed by Executive Order 13123 as a follow-on to the 1992 Energy Policy Act. These orders forced Federal agencies to develop water conservation programs and implement water conservation measures for all Federal facilities. One of the options designated as a best management practice for water conservation under Executive Order 13123 is water reuse and recycling.

This paper addresses the various issues that Navy facility planners must consider when attempting to implement water reuse projects on Naval installations. Only non-potable uses are considered, since the vast majority of potable water consumed on a base is not for potable (consumption) use. Rather, it is used for various industrial, commercial, residential, and sanitary applications. Further, the expense and lack public acceptance regarding water reuse for potable purposes often makes this option impractical. As such, potable reuse is not addressed in this paper. For purposes of discussion, the terms "Naval installations" and "Navy installations" refer to U.S. Navy and Marine Corps-owned facilities operated and managed by the Naval Facilities Engineering Command (NAVFAC) within the continental United States and around the world.

To date, no definitive guidance has been published by NAVFAC or other authority specifically addressing planning and implementation of water reuse projects. Existing water and energy conservation publications refer to water reuse as one of many design alternatives, but only with limited detail. Although water reuse is not new, a number of complex factors exist for planning and executing projects of this nature. This report attempts to categorize these issues and develop baseline guidance for Navy facility and energy managers regarding water reuse applications. Sections 2 through 11 of this paper are organized to illustrate each distinct aspect of the water reuse planning and implementation process. Each section is briefly described below:

- Section 2 - U.S. Navy Water Conservation Program: This section addresses the various aspects of the U.S. Navy Water Conservation Program as they relate to water reuse. Specifically, the scope of Executive Orders 12902 and 13123 are discussed as well as key milestones and best management practices they set forth.
- Section 3 - Legal Issues: Compliance with Federal, state, and local environmental regulations with respect to water reuse are discussed. A brief review of the existence and degree of state laws regulating water reuse is included. Finally, water rights considerations when planning reuse projects are examined.
- Section 4 - Water Treatment Processes: This section describes the various processes that may be used as part of a treatment scheme to improve the quality of reclaimed water to meet Federal or state quality standards. Four distinct categories of treatment, including pretreatment, primary treatment, secondary treatment, and advanced treatment are evaluated.
- Section 5 - Industrial Uses: Major industrial functions on Naval installations are evaluated for potential water reuse applications. They include: vehicle and aircraft washing

facilities, plating operations, metal cleaning facilities, industrial laundry facilities, and cooling systems.

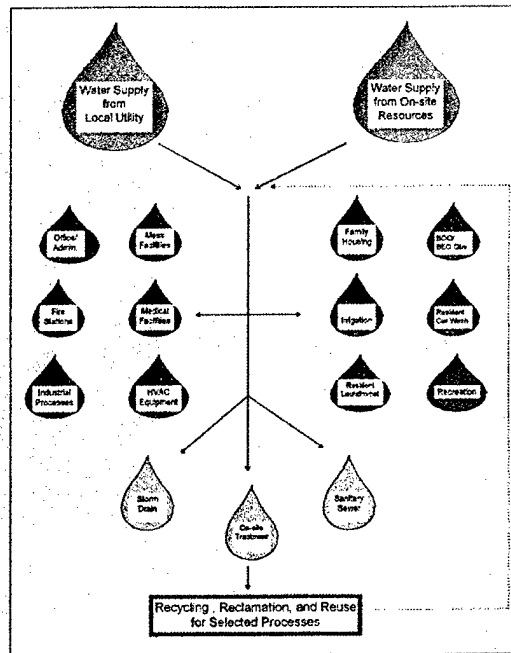
- Section 6 - Irrigation: Irrigation options using secondary municipal wastewater effluent and reclaimed greywater are considered for residential and commercial applications.
- Section 7 - Toilet and Urinal Flushing: Design of greywater collection and treatment systems for toilet and urinal flushing in office and industrial facilities is evaluated in this section.
- Section 8 - Water Storage Facilities: Open and enclosed water storage facilities for reuse applications are described in this section.
- Section 9 - Risk Management: Procedures for analyzing the three major factors in a risk management decision; risk assessment, costs, and public opinion are described.
- Section 10 - Economic Considerations: Major economic considerations of a water reuse project include: benefits, reliability, timing, and optimization. Each is addressed in this section.
- Section 11 - Implementing Water Reuse Projects: The steps that planners must take to implement water reuse projects are described. Sources of funding, submittal requirements, education, and monitoring results are all discussed.

The last two sections of the paper are a synthesis of ideas and issues discussed in Sections 1 through 11. Section 12 is a case study of the U.S. Naval Construction Battalion Center, Gulfport, MS that evaluates various options for water reuse at that installation. Finally, Section 13 includes conclusions drawn about the planning and implementation process, along with recommendations for the future of water reuse at Naval installations.

A number of technical terms are used throughout this report to describe the various processes and applications related to water reuse. They are defined in Appendix I.

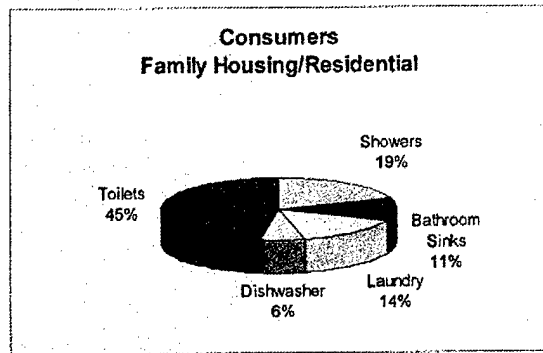
## 1.2. THE NEED FOR WATER REUSE

According to the U.S. Geological Survey (USGS), over 450 billion gallons of ground and surface water is withdrawn on a daily basis in the United States. That is more than 3 times the amount of water used by other parts of the world. The Department of Energy estimates that the Federal government uses more than 23 billion gallons of water per year and spends more than \$60 million annually on water consumption and sewage disposal costs. However, many installations do a poor job of monitoring and regulating water use, especially in areas where water is considered to be abundant. Typical water uses on a Naval installation are shown in Figure 1 below:

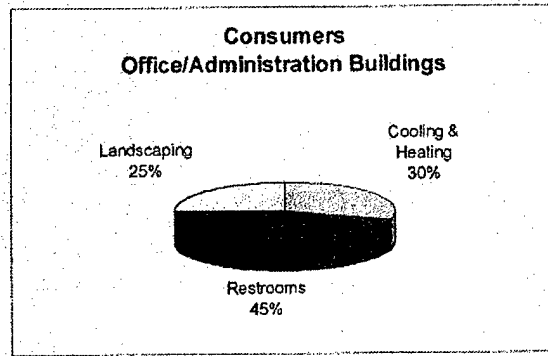


**Figure 1 - Typical Water Uses at a U.S. Naval Installation (NFESC, 1993)**

Typical breakdowns of water uses in residences and office buildings are shown in Figures 2 and 3 below (NFESC, 1993):



**Figure 2 - Residential Usage (NFESC, 1993)**



**Figure 3 - Office Usage (NFESC, 1993)**

Water reuse is one method for reducing potable water consumption. As indicated from the figures above, the largest water use in most buildings comes from toilet and urinal flushing. Irrigation, cooling, laundries, and process water also account for a significant portion of water use on a base. Moreover, the majority of this water is used only once then disposed of. In many cases, potable quality water is not required to maintain process efficiency or even to perform the intended function. For example, water in toilets and urinals is only used to transport wastes to the sewer system. The quality of water has virtually no impact on the rate of transport or ultimate treatment of these wastes. However, the prevailing trend in design of water-using facilities on Navy bases has been to incorporate potable water instead of lesser quality reclaimed sources. In order for water reuse to be a successful and viable alternative, consideration of reuse options must be incorporated into the mindset of planners and designers when developing new facility requirements or upgrades to existing ones.

Many bases exist in arid regions of the U.S., such as California and Nevada. Water availability and rights in these areas have been hotly contested for years. Population surges have

placed even further strains on already limited water supplies. Numerous military bases are located in Florida, where saltwater intrusion has contaminated many underground aquifers, due to overuse. Finally, severe droughts in the eastern and southern U.S., typically considered water-rich areas, have forced many communities to reevaluate their water use practices. Navy installations have not been immune from these problems. Since many installations rely on off-base sources of drinking water and sewage treatment, water restrictions have affected Navy operations as well. Water reuse alternatives provide a means of relief from water restrictions, droughts, and other factors impacting the availability of potable water by reducing consumption on the installation. Further, they allow bases to plan for growth without adversely impacting future potable supplies.

## **2. U.S. NAVY WATER CONSERVATION PROGRAM**

In 1992, the U.S. Congress passed the Energy Policy Act. This was the first of many steps taken to reduce energy and utilities consumption at Federal facilities. It was soon followed by Executive Order 12902 in 1994, which established the Federal Energy Management Program. The Department of Energy (DOE) and General Services Administration (GSA) were placed in charge of this program. NAVFAC has been assigned as the lead agent for energy and water conservation programs and policies for the U.S. Navy. Within NAVFAC, the Naval Facilities Engineering Service Center (NFESC) in Port Hueneme, CA serves as the primary point of authority for all water and energy conservation related issues. The purpose of the Navy Water Conservation Program is to develop methods to reduce water consumption on Naval facilities to meet the goals set forth in Executive Order 12902 and most recently in Executive Order 13123. Goals of the Navy Water Conservation Program are described in terms of the guidelines established in each of these executive orders. While many water-saving measures are available for use on Navy installations, only water reuse options are considered in the context of this paper.

### **2.1. EXECUTIVE ORDER 12902**

Executive Order 12902, "Energy Efficiency and Water Conservation at Federal Facilities," was issued in March 1994. It mandates that all Federal agencies must take specific actions to reduce energy and water consumption at federally owned facilities. Moreover, it requires that energy consumption in Federal buildings be reduced by 30% from 1985 levels by the year 2005. Although the central focus is on energy conservation, water conservation is addressed as well. The primary agencies responsible for implementing Executive Order 12902

are NAVFAC, DOE, and the General Services Administration (GSA). A summary of their roles, along with those for each Federal facility regarding water conservation is shown in the figure below:

DOE Department of Energy	GSA General Services Administration	NAVFAC/COM NAVFAC ENGINEERING COMMITTEE	Facility
<ul style="list-style-type: none"> <li>◆ Implement EO 12902 through FEMP.</li> <li>◆ Develop indicators of water efficiency, consumption, and cost.</li> <li>◆ Prepare report on issues of instituting life cycle analysis.</li> <li>◆ Develop recommendations to assist agencies in eliminating procurement barriers to implementing EO.</li> <li>◆ Develop agency technical assistance services to identify/implement water conservation opportunities.</li> <li>◆ Explore ways to stimulate water conservation in federal facilities (Sec. of Energy with GSA).</li> <li>◆ Develop program to train/support agency water conservation project teams.</li> <li>◆ Through FEMP, develop an agency service program and assign account managers to each agency.</li> <li>◆ Identify advanced technologies not yet on the market.</li> <li>◆ Provide guidance on the retirement of older water using equipment (With GSA).</li> <li>◆ Provide guidance on or make available:               <ul style="list-style-type: none"> <li>◆ Water and energy consumption and savings relationships.</li> <li>◆ Innovative water conservation funding methods.</li> <li>◆ List of national water service companies.</li> <li>◆ Information on capabilities and technology through National Energy labs.</li> <li>◆ List of qualified water efficiency contractors for federal projects.</li> </ul> </li> </ul>	<ul style="list-style-type: none"> <li>◆ Determine GSA contracted utilities which perform no-cost audits.</li> <li>◆ Determine utilities which offer demand-side management services and incentives.</li> <li>◆ Develop efficient procurement techniques, methods, and contracts.</li> <li>◆ Provide information on specific water conservation products.</li> </ul>	<ul style="list-style-type: none"> <li>◆ Comply with DOD (deemed the "agency") in carrying out EO 12902.</li> <li>◆ Manage ECIP and FEMP funding for water and energy conservation projects.</li> <li>◆ Recommend projects to Secretary of Defense for FY funding.</li> <li>◆ Issue Navy policies and guidelines to implement water conservation projects.</li> <li>◆ Develop Navy-wide execution plan for water projects.</li> </ul>	<p>Obtain assistance as needed from DOE, GSA, NAVFAC, NFESC etc, to:</p> <ul style="list-style-type: none"> <li>◆ Develop a facility water conservation plan.</li> <li>◆ Conduct facility water audit.</li> <li>◆ Determine water conserving measures.</li> <li>◆ Implement water conservation measures.</li> </ul>

**Figure 4 - Organizational Roles for Water Conservation (NFESC, 1993)**

## 2.2. EXECUTIVE ORDER 13123

In May 2000, Executive Order 13123, "Guidance to Establish Water Efficiency Improvement Goal for Federal Agencies" was promulgated by President William J. Clinton, which superseded Executive Order 12902. It states that all Federal agencies are required to reduce potable water use on Federal facilities using life cycle cost-effective water efficiency programs that include a water management plan. In addition, they must implement at least four FEMP Water Efficiency Improvement Best Management Practices (BMP) as defined in the order.

Water management plans must be developed for all Federal installations and should indicate how a facility uses its water, all the way from the water source to disposal. The following information must be included in a water management plan:

- Operation and maintenance recommendations
- Utility information, including points of contact, rate schedules, copies of water and sewer bills dating back at least 2 years, sources of financial and technical assistance, and production information.

- Facility information
- Emergency response information
- Comprehensive planning to incorporate all aspects of facility operation.

Executive Order 13123 outlines ten potential best management practices that agencies can implement on Federal installations. They include:

- BMP # 1 - Public Information and Education Programs
- BMP # 2 - Distribution System Audits, Leak Detection & Repair
- BMP # 3 - Water Efficient Landscape

- BMP # 4 - Toilets and Urinals
- BMP # 5 - Faucets and Showerheads
- BMP # 6 - Boiler/Steam Systems
- BMP # 7 - Single-Pass Cooling Systems
- BMP # 8 - Cooling Tower Systems
- BMP # 9 - Miscellaneous High Water Using Processes
- BMP #10 - Water Reuse and Recycling

The primary emphasis of this paper is on planning and implementing projects in accordance with BMP #10, "Water Reuse and Recycling". BMP #10 focuses on substitution of non-potable water for uses that are currently served by potable supplies. Both treated secondary municipal wastewater effluent and greywater sources should be considered for non-potable water reuse. Treated secondary effluent is preferred over greywater, due to high capital costs associated with retrofits and potential health concerns. However, greywater systems are considered in this paper as potential options for residential irrigation and toilet/urinal flush water. BMP #10 also recommends that non-potable reuse alternatives are included in the design of new facilities, which is generally more cost effective than funding retrofits.

### **3. LEGAL ISSUES**

There are a number of regulatory issues that must be addressed when planning a water reuse project on a Navy installation. Federal environmental laws, namely the National Environmental Policy Act, Clean Water Act, and Safe Drinking Water Act, will likely require some level of compliance. While none of these laws specifically address water reuse, they all regulate the impact of contaminant loading on the environment. Many states have implemented water reuse regulations, which will apply depending on the location of the installation. Where no state regulations apply, the U.S. Environmental Protection Agency (EPA) has developed recommended water quality and planning guidelines for reuse applications. Finally, existing water rights doctrine, especially in the Western U.S., may impact on the extent and nature of water reuse projects. This section highlights the key areas of concern for installation planners as they apply to water reuse.

#### **3.1. FEDERAL ENVIRONMENTAL REGULATIONS**

As stated above, no specific Federal laws explicitly regulate water reuse. However, due to the nature of water reuse projects, they may fall under the jurisdiction of one or more Federal environmental laws. The National Environmental Policy Act (NEPA), Clean Water Act (CWA), and Safe Drinking Water Act (SDWA) are of primary concern. Since Navy installations are federally controlled, NEPA compliance will be necessary. Further, many water reuse projects rely on secondary municipal wastewater effluent, which is regulated under the Clean Water Act. Finally, if groundwater or potable water supplies are potentially impacted by a water reuse scheme, Safe Drinking Water Act requirements may apply. Each of these regulations is discussed below:

### *3.1.1. National Environmental Policy Act*

The National Environmental Policy Act was enacted in 1969 to establish a national environmental policy that all Federal agencies must adhere to. Specifically, all Federal agencies must consider the environmental consequences of all proposed legislation and other major Federal actions. Major Federal actions include:

- Programs conducted, regulated or approved by the Federal government
- Projects entirely or partially financed with Federal funds
- New or revised policies, regulations, procedures, and legislative proposals
- Plans created to guide or specify use of Federal resources

Under NEPA, a detailed statement must be prepared to address significant environmental effects resulting from proposed legislation or major Federal actions, alternatives to the proposed actions, and the relationships between environmental damage and benefits from implementing the proposed strategy. This document is known as an Environmental Impact Statement (EIS). Preparation of an EIS is an extremely long, intensive, and costly process. Fortunately, there are many instances where an EIS is not required.

Water reuse projects are defined as major Federal actions, since they are funded and conducted by the government. The first step in determining whether a water reuse project is subject to NEPA (specifically, whether an EIS is required), is to perform an Environmental Assessment (EA). An EA is a 10-15 page document prepared to provide sufficient evidence and analysis as to whether an EIS will be required. The impact of the proposed project and its alternatives are reviewed to determine if there will be a significant impact on the environment as a result of implementation. If no adverse impacts are discovered, the Navy may issue a Finding of No Significant Impact (FONSI). The FONSI will satisfy NEPA requirements, without having

to perform an EIS. However, if potentially significant environmental impacts exist, an EIS will need to be prepared (White, 2003; Kontos and Asano, 1996).

Some projects may be considered “categorical exclusions”, in that they are specifically exempted from NEPA requirements. Categorical exclusions do not require an EIS, but are very limited. The Federal or state Council on Environmental Quality (CEQ) should be contacted regarding categorical exclusions (White, 2003).

The standard format for an Environmental Impact Statement is as follows (Aston, 2003):

- Cover Sheet
- Summary
- Table of Contents
- Purpose of and Need for Action
- Alternatives Including Proposed Action
- Affected Environment
- Environmental Consequences
- List of Preparers
- List of Agencies, Organizations, and Persons to Whom Copies are Sent
- Index
- Appendices

The process of preparing an EIS is briefly described below (Kontos and Asano, 1996):

- Notice of Intent: A notice of intent must be published in the Federal Register. It includes a description of the project, an overview of the scoping process, and key points of contact.
- Scoping: Scoping involves the determination of issues to be included in the EIS. This typically involves public input and coordination with other agencies.

- Draft EIS: A Draft EIS must be prepared and sent for review by Federal and state agencies with jurisdiction, expertise, or interest in the project. It must also be available to the public, upon request. The review and comment period will last 45 days or more. The Draft EIS is also filed with the EPA.

- Final EIS: After comments from the Draft EIS have been received, they are incorporated into the Final EIS. The Final EIS must address all concerns and comments from the Draft EIS. Copies of the Final EIS are sent to all reviewers of the draft EIS. A notice must be filed with EPA, who will then publish it in the Federal Register. A 30-day review period is required to make all necessary changes before the Final EIS can be adopted.

### *3.1.2. Clean Water Act*

The Federal Water Pollution Control Act (also known as the Clean Water Act or CWA) was promulgated by Congress in 1972. Its primary objective is to restore and maintain the quality of U.S. waters to a level that provides for protection of fish and wildlife and allows for recreation in and on the water. The CWA specifically prohibits discharge of any pollutant by any person into any navigable waters, unless an exception has been made. Navigable waters refer to all "waters of the United States", including rivers, lakes, streams, impoundments, tributaries, wetlands, and the like. Groundwater and water/wastewater treatment plants are not considered navigable waters and are therefore not regulated under the CWA. Exceptions to the no-discharge rule are normally handled through the National Pollution Discharge Elimination System (NPDES). In order to discharge any quantity of pollutant into any navigable water, the polluter must obtain an NPDES permit. For water reuse projects, this may be the local wastewater treatment plant or the installation, depending on the nature of the project. NPDES permits are administered by the state environmental authority (i.e. Maryland Department of the

Environment) and overseen by EPA. The permits will typically set numerical limits for the concentration (i.e. mg/L) or total loading (i.e. g/yr) of pollutants that may be discharged into the environment. Requirements are usually state-specific and are designed to maintain the quality of a state's water bodies. However, they will be at least as stringent as EPA standards for individual pollutants. Although CWA standards primarily address point source polluters (i.e. pipes, culverts, etc.), provisions for non-point source pollution (i.e. runoff) also exist (White, 2003).

In many cases, water reuse projects are designed to reduce pollutant loading to navigable waters by diverting some of the effluent from municipal wastewater treatment plants for use on Navy installations. This strategy has two benefits. First, a reduction in pollutant loading allows for future expansion of the treatment plant without obtaining another NPDES permit. Also, it allows for reduction in potable water consumption by the base. However, if the installation does not take appropriate measures to prevent discharge of the reuse water (treated or not) to navigable waters, the Navy becomes liable under the Clean Water Act. In many cases, this cannot be avoided and the installation must apply for an NPDES permit. For example, storage ponds containing reclaimed water for golf course irrigation will require an NPDES permit. The ponds, whether manmade or natural, pre-existing or not, are by definition navigable waters, and therefore subject to the CWA. Input of reclaimed water, even if it is of higher quality relative to existing water in the pond, can only be done with an NPDES permit.

Runoff is another concern when using water reuse applications on a base. Systems must be designed to minimize or collect runoff to prevent contamination of surface waters. As previously indicated, runoff is a non-point pollution source and subject to the CWA.

### *3.1.3. Safe Drinking Water Act*

The Safe Drinking Water Act is designed to protect sources of drinking water and regulate the systems that provide it. A number of provisions in the 1986 amendments to the SDWA have potential implications for water reuse projects. Most importantly, maximum contaminant levels (MCL) were established as health-based standards to control contaminant concentrations in drinking water. If these standards are exceeded, the municipality or installation (depending on who controls the drinking water source) may be liable. Two applicable programs designed to enhance groundwater protection were also included in the 1986 SDWA amendments. They are the Underground Injection Control Program (UICP) and the Sole-Source Aquifer Program (SSAP). The UICP is designed to protect usable aquifers and regulates the use of injection wells. The SSAP prohibits the use of Federal funds on projects that may contaminate critical potable aquifers (White, 2003).

Land use applications, such as irrigation and non-potable aquifer storage, will frequently face SDWA compliance issues. For example, many states strictly regulate nitrogen in groundwater, due to its deleterious effects on water quality. Unless nitrogen can be removed in treatment to extremely low levels, irrigation with reclaimed water may cause MCLs to be exceeded. This is also true for other contaminants that may be present in wastewater and introduced to drinking water sources. Non-potable aquifer storage has been considered as an efficient means for storing reclaimed water for later use. However, the potential to contaminate nearby potable aquifers will often prevent their use. Further, under the SSAP, if there is a potential to contaminate potable aquifers, the project cannot legally be funded. In order to overcome these regulatory hurdles, treatment processes must be designed to reduce contaminants

in municipal wastewater effluent or greywater sources to acceptable levels. Treatment options are described in detail in Section 4.

### 3.2. STATE LEVEL WATER REUSE REGULATIONS

A number of states have developed regulations regarding water reuse in their jurisdictions. As of 1992, 18 of the 50 states had specific regulations, 18 others had guidelines or design standards, while 14 had no standards. State regulations and guidance documents are typically broken down into several categories, including (EPA, 1992):

- Water Quality and Treatment Requirements: The most common reuse regulations involve water quality and treatment requirements. Unrestricted urban reuse typically has the highest standards, due to the high exposure potential. Other uses, where public exposure is less likely, generally have less stringent standards. BOD, TSS, coliforms, and turbidity are the most common water quality parameters included in state water reuse regulations.
- Monitoring Requirements: Monitoring involves routine examination of water quality parameters, such as turbidity and fecal coliforms, to ensure that the reuse system is operating correctly and treatment processes are effectively reducing contaminant levels to within regulatory standards.
- Treatment Facility Reliability: Many states have incorporated reliability provisions into water reuse regulations. The purpose of these provisions is to ensure that treatment systems are operating at all times and to minimize bypass or flow-through potential, due to treatment system inoperability. Reliability regulations include use of alarms for warning of power or essential systems failures, use of automatic standby power, emergency storage, and redundant systems for treatment processes.

- Minimum Storage Requirements: Minimum storage requirements are implemented to limit or prevent surface water discharge of treated reuse water. Most states do not differentiate between operational and seasonal storage.

- Application Rates: Application rate requirements typically pertain to land application uses (i.e. land treatment, irrigation, etc.). They are normally set well above irrigation demands, since the intent of water reuse is to reduce discharges to water bodies. As such, the more treated water that is applied to land, the better. Many states have limits on nitrogen loading, due to potential groundwater contamination.

- Groundwater Monitoring: Many states require groundwater monitoring, especially for land application uses. At least one well is required to be placed up-gradient of the reuse site to observe background conditions. Typically, at least two or more wells must be placed down-gradient from the site to assess water quality and contaminant transport. The primary focus of a groundwater-monitoring program is the quality of aquifers close to the surface, since they have the highest potential for being adversely affected by water reuse.

- Setback Distances: Often, setback distances or buffer zones will be required between irrigation sites and potable wells, property lines, residential areas, and roadways in order to minimize the potential for human contact with reclaimed water.

A summary of guidelines and regulations for each of the 50 states is shown on the following page. Individual state environmental regulatory agencies should be contacted for specific guidance regarding each of these requirements.

STATE	Regulations	Guidelines	No Regulations or Guidelines (2)	Unrestricted Urban Reuse	Restricted Urban Reuse	Agricultural Reuse Food Crops	Agricultural Reuse Non-Food Crops	Unrestricted Recreational Reuse	Restricted Recreational Reuse	Environmental Reuse	Industrial Reuse
Alabama											
Alaska											
Arizona											
Arkansas											
California											
Colorado											
Connecticut											
Delaware											
Florida											
Georgia											
Hawaii		(1)									
Idaho											
Illinois	(1)										
Indiana											
Iowa											
Kansas											
Kentucky											
Louisiana											
Maine											
Maryland											
Massachusetts											
Michigan											
Minnesota											
Mississippi											
Missouri											
Montana											
Nebraska											
Nevada		(1)									
New Hampshire											
New Jersey											
New Mexico											
New York											
North Carolina											
North Dakota											
Ohio											
Oklahoma											
Oregon											
Pennsylvania											
Rhode Island											
South Carolina											
South Dakota											
Tennessee											
Texas											
Utah											
Vermont											
Virginia											
Washington											
West Virginia											
Wisconsin											
Wyoming											

(1) Draft or Proposed

(2) Specific regulations on reuse have not been adopted; however, recclamation may be approved on a case-by-case basis.

Figure 5 - Individual State Water Reuse Guidelines and Regulations (EPA, 1992)

### 3.3. EPA RECOMMENDED GUIDELINES FOR WATER REUSE

EPA has developed a set of guidelines that can be followed when planning water reuse projects where no state regulations exist. Guidelines have been categorized based on the nature of the reuse as follows:

- Urban Reuse: Includes all types of landscape irrigation, vehicle washing, toilet flushing, fire protection, air conditioning systems, and similar applications. Urban reuse can be restricted or unrestricted, depending on the level of public access. Restricted urban reuse typically applies to areas where public access can be controlled, such as private golf courses and highway medians.
- Restricted Access Area Irrigation: Includes sod farms and other areas where public access is prohibited or otherwise restricted.
- Agricultural Reuse on Food Crops: Includes irrigation of food crops that will ultimately be consumed by humans. This use is further classified based on whether the crops are commercially processed or consumed raw.
- Agricultural Reuse on Non-Food Crops: Includes irrigation of fodder, fiber, and seed crops, pastures, and commercial nurseries.
- Recreational Impoundments: Water bodies that are used for recreation. They are further classified as restricted or unrestricted use. For unrestricted use, body contact (i.e. swimming) in the water is allowed. In restricted use, recreation is limited to activities such as boating and/or fishing.
- Landscape Impoundments: Includes aesthetic uses where public contact is not allowed.
- Construction Uses: Reclaimed water used for soil compaction, dust control, aggregate washing, and concrete.

- Industrial Reuse: Includes applications in industrial facilities, primarily cooling systems, process water, rinsing, and washdown.
- Environmental Reuse: If reclaimed water is used to create artificial wetlands, habitats, or enhance existing ones, it is considered environmental reuse.
- Groundwater Recharge: This includes surface application or injection of reclaimed water for purposes of creating a non-potable aquifer.
- Indirect Potable Reuse: This includes surface application or injection of reclaimed water into an existing potable aquifer to augment groundwater or surface water supplies.

Detailed guidelines are included as Appendix II (EPA, 1992).

### 3.4. WATER RIGHTS

A water right is the right to use water. This does not constitute ownership of the water. Individual states typically retain ownership of water sources within their boundaries. Water rights also allow for diversion of water from a particular source to serve a particular purpose. The primary stipulation is that harm cannot be inflicted on other parties that have a claim to the water.

Two systems of water rights currently exist in the United States. They are the riparian and appropriative systems. The riparian system is used mainly in areas of the Eastern U.S. or where water abounds. The water right is based on an individual's proximity to a water source. For example, if a landowner lives next to a river, he/she is entitled to receive the full flow of the river without any loss in quality or quantity. However, the riparian owner also cannot use the water in a manner that will result in a substantial loss of quality or quantity. Essentially, each riparian owner (assuming there is more than one) is guaranteed an equal share and quality of

water. The appropriative system is found mostly in the Western U.S. or where water is scarce. Appropriative rights also typically control groundwater use. They are based on the principle that water rights are assigned to users. Whoever first uses the water has the primary claim. If there is a shortage, the first user will be guaranteed his/her share before subsequent users. Specific amounts of water are guaranteed to appropriative users. If they are not used, the rights are lost (i.e. quantities are not compounded).

In water poor areas, appropriative rights do not need to be obtained for already scarce water if reclaimed water sources are available. This is especially important when the water rights received are lower priority than the existing users (under the appropriative system). On the other hand, water rights can present some obstacles to water reuse projects. If water reuse reduces natural water flow or quality, then water rights may be violated. Further, appropriative states may have regulations limiting the area(s) where the water can be used. For example, if the treatment plant is in a different area than the base, the water may be off-limits. Finally, both riparian and appropriative systems include hierarchies of importance of water users and uses. Depending on the nature of use and availability of other water sources, water rights conflicts may arise.

## **4. WATER TREATMENT PROCESSES**

Numerous water treatment processes can be employed to remove contaminants and bring reclaimed water sources in compliance with Federal and state reuse guidelines. There are four general categories of water treatment, each preceding the next. They are:

- Preliminary Treatment
- Primary Treatment
- Secondary Treatment
- Advanced Treatment

If secondary municipal effluent is used as a water source, it will have undergone some form of treatment in each of the first three categories, and potentially some level of advanced treatment, depending on site-specific conditions. Greywater is untreated and will require varying degrees of treatment, depending on the intended application. Each of the four treatment categories is discussed in detail in the following sub-sections. In addition, land applications are considered as alternatives to conventional treatment technologies.

### **4.1. PRELIMINARY TREATMENT**

Preliminary treatment involves removal of large solid particles and other materials that may damage subsequent treatment units. Screening, comminution, and grit removal are common processes used for this task. Many treatment plants also incorporate flow equalization to maintain a constant operating environment, properly size treatment units, and ensure continued process efficiency.

#### *4.1.1. Screening*

Typically the first process in a wastewater treatment scheme, the purpose of screening is to remove large solid materials that could potentially damage the distribution system and downstream treatment equipment, reduce treatment efficiency, and contaminate water bodies. Influent passes through a metal screen with uniform openings, which retains the solid material. Screen openings may be classified as coarse (6 to 150 mm), fine (< 6 mm), or micro (< 50  $\mu\text{m}$ ), depending on the size particles they are intended to remove. Coarse screens are generally composed of parallel bars or rods, and are often referred to as "bar racks". Fine screens are constructed of perforated plates or wire cloth. Screens may be either manually or mechanically cleaned (Metcalf and Eddy, 2003).

#### *4.1.2. Comminution*

Comminution is an alternative to screening influent wastewater, wherein coarse solid materials are grinded or shredded by mechanical units and subsequent treatment processes remove the resulting particulates. The main advantage of comminution is that there are no screens to be cleaned, which can often be an unpleasant task. There are three types of units commonly used. They include comminutors, macerators, and grinders. Comminutors are used primarily for small treatment systems (less than 5 MGD). They use a stationary horizontal screen to intercept inflow and a rotating arm with cutting teeth to mesh with the screen. Macerators operate at slow speeds with two sets of counter-rotational cutting assemblies. Material is chopped up as it passes through the unit. Grinders are high-speed machines used in conjunction with bar racks. A high speed rotating knife assembly cuts the materials received from the bar racks. Wash water introduced into the unit keeps it clean and sends the shredded material back into the wastewater stream (Metcalf and Eddy, 2003).

#### *4.1.3. Grit Removal*

Grit removal typically occurs after screening or comminution and before primary treatment facilities. The purpose of this process is to remove inorganic solids (i.e. gravel, sand, coffee grounds, etc.) from the wastewater, which may cause problems in subsequent treatment units. Grit chambers are designed to only remove particles with specific gravity greater than 2.5 (most inorganic matter). Lighter organic particles are allowed to pass through for removal in later processes. The types of grit chambers include horizontal flow, aerated, and vortex-type. Horizontal flow chambers may be either rectangular or square. Influent enters one side of the chamber and flows horizontally in the tank until it reaches a discharge weir. In aerated grit chambers, air is pumped to one side of the tank, which creates a spiral flow perpendicular to the wastewater flowing through the chamber. This process helps to increase grit removal efficiency, and close to 100% removal can be achieved with these types of grit chambers. Finally, vortex-type grit chambers employ a rotating turbine to create a vortex flow pattern to promote separation of organic and inorganic material. The grit is then collected at the bottom of the tank in a hopper (Hao, 2003; Metcalf and Eddy, 2003).

#### *4.1.4. Flow Equalization*

Flow equalization facilities are designed to achieve a constant flow rate into treatment facilities. Incoming wastewater flows typically vary with time of day, season, and a number of other factors. In order to maximize treatment efficiency, reduce shock loading, and design correctly sized treatment units, flow equalization is often necessary. There are two types of configurations that can be employed. The first is called on-line (or in-line) equalization. Here, all of the incoming wastewater enters the basin and is discharged at a constant output rate. The other type, called off-line equalization, is not directly in the treatment train. Instead, its use is

based on a predetermined average flow rate for the system. If the flow is higher than average, the excess flow is diverted into the basin. If flow is below average, water is pumped from the equalization basin to maintain constant flow (Hao, 2003; Metcalf and Eddy, 2003). A typical equalization basin is shown in Figure 6 below:

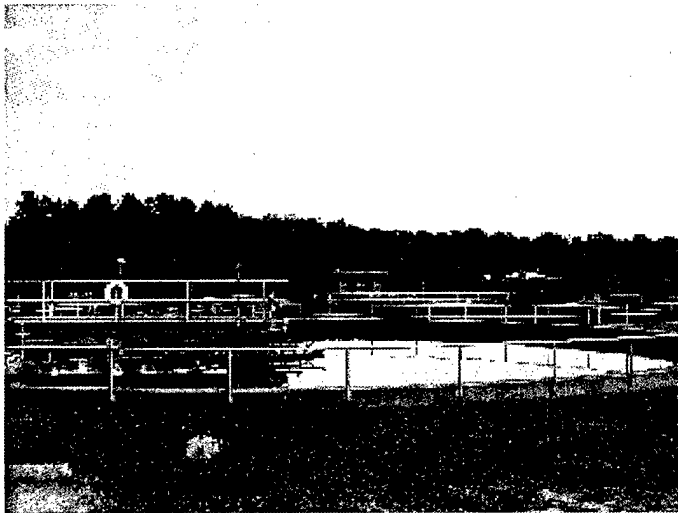


**Figure 6 - Equalization Basin**

#### **4.2. PRIMARY TREATMENT**

Primary sedimentation is typically accomplished with rectangular or circular sedimentation basins (clarifiers), which are designed to remove organic settleable solids and floating material from the waste stream. In rectangular tanks, water flows over an influent weir and along the length of the tank at a slow velocity, while solids settle on the tank bottom. Chain and flight conveyors or traveling bridge type collectors are used to remove the settled material from the tank for further processing and disposal. In circular tanks, influent can either be introduced along the periphery of the tank or through an outlet at the center. Typically, the former configuration (referred to as rim-feed) is used, because it produces higher removal efficiency. A continuous effluent channel, composed of v-notch weirs is located approximately

75% of the radial distance from the tank center. Skimmers collect residue in the influent and effluent channels and settled solids in the bottom of the basin are scraped to a center hopper, where they are pumped to sludge treatment facilities. Some organic nitrogen, organic phosphorous, and heavy metals may be removed during primary sedimentation. However, to achieve contaminant concentrations acceptable by most EPA and state water reuse guidelines, further treatment is almost always required. Addition of chemical coagulants, such as alum, ferric chloride, and lime can increase the removal efficiency of these compounds. More information on coagulants can be found in Section 4.4, Advanced Treatment (Metcalf and Eddy, 2003; EPA, 1992; Envirex, 1989). A typical primary clarifier is shown in Figure 7 below:



**Figure 7 - Primary Clarifier**

### 4.3. SECONDARY TREATMENT

Secondary treatment normally involves aerobic biological treatment followed by secondary sedimentation. The primary purpose of secondary treatment is to reduce BOD and nutrient content in the water. The most popular form of aerobic biological treatment is the activated sludge process. To a lesser extent, trickling filters, rotating biological contactors, aerated lagoons, and stabilization ponds may also be used. Sedimentation facilities are employed to remove suspended material created during biological treatment and improve water quality.

#### *4.3.1. Aerobic Biological Treatment*

Aerobic biological treatment is performed to reduce organic matter (BOD), microorganisms, and in some instances nitrogen and phosphorous in the water. As the name suggests, this type of treatment is performed in an aerobic (oxygen-rich) environment, allowing microorganisms in the treatment system to oxidize organic and other matter present in the water. Aerobic biological treatment processes can be classified as high-rate and low-rate, based on the concentrations of microorganisms used. High-rate processes use high microbial concentrations, where low-rate processes use lower concentrations.

##### **4.3.1.1. High-Rate Processes**

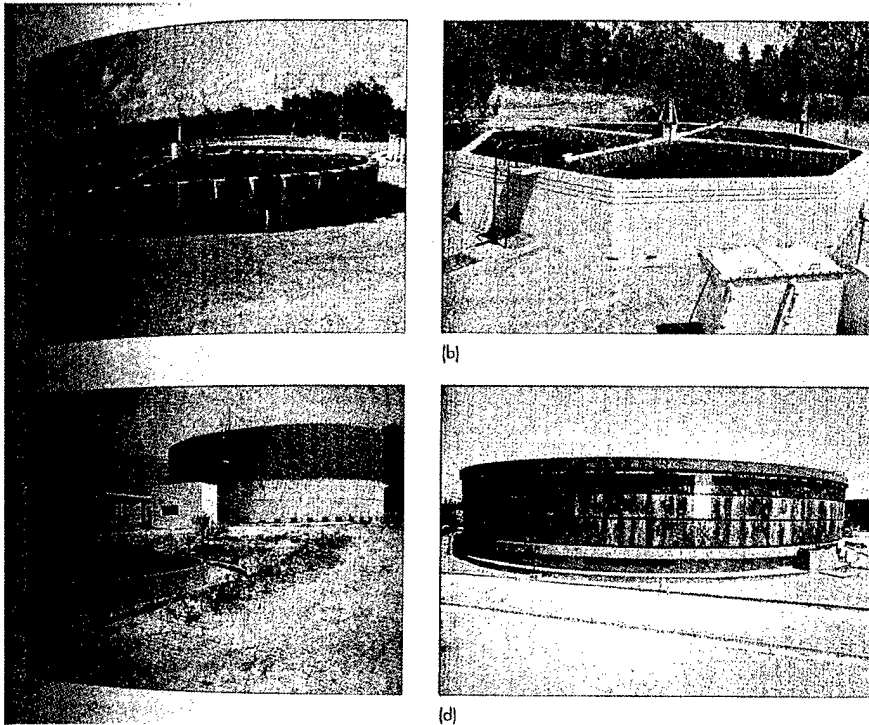
Standard high-rate biological treatment includes activated sludge, trickling filters, and rotating biological contactors. Activated sludge is further classified as a suspended growth process, since the microorganisms used for treatment (commonly referred to as Mixed Liquor Suspended Solids (MLSS)) are suspended in the treatment tank. Trickling filters and rotating biological contactors are attached growth processes, since the microorganisms are attached to the treatment media (Hao, 2003; EPA, 1992).

#### 4.3.1.1.1. Activated Sludge

In the activated sludge process, an aerated tank reactor is used to maintain the MLSS responsible for biological treatment. A portion of the influent organic matter is converted to carbon dioxide, while the remaining matter is synthesized to produce more biomass. The effluent is sent to secondary sedimentation facilities, where the treated wastewater is separated from the MLSS. A portion of the settled solids in the secondary clarifier is recycled back to the head of the activated sludge tank to provide a continuous supply of microorganisms. The remaining solids are sent to sludge processing facilities. Close to 90% BOD removal can be obtained using the activated sludge process. Over the years, multi-stage activated sludge systems have been developed to remove other nutrients, such as nitrogen and phosphorous in the water to meet increasingly stringent treatment requirements. These are briefly addressed in Section 4.4, Advanced Treatment (Hao, 2003).

#### 4.3.1.1.2. Trickling Filters

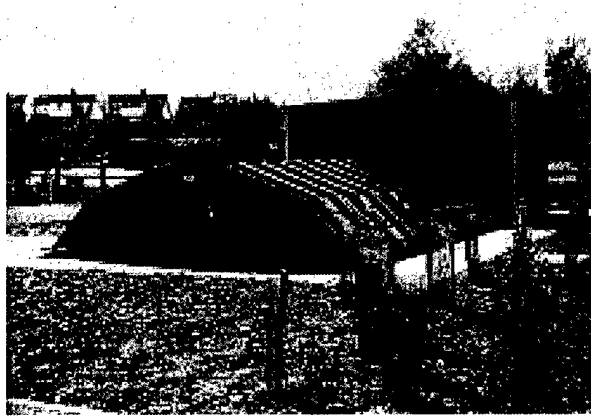
Trickling filters are composed of a rock or plastic media bed on top of an underdrain system. Water is distributed over the top of the media and allowed to percolate through. The effluent is then sent to secondary clarifiers. The biomass that treats the water grows on the media surface and continues to accumulate as more wastewater is applied over time. Eventually, some of the biomass dies due to lack of oxygen and falls off the media. These "sloughed" solids, as they are called are removed during secondary sedimentation. Typically, around 70% BOD removal can be obtained using trickling filters. Unlike activated sludge, trickling filters are less effective in removing other organic compounds, due to less contact between the media (biomass) and wastewater (EPA, 1992; Noyes, 1980). Some trickling filter configurations are shown on the following page:



**Figure 8 - Standard Trickling Filter Configurations (Metcalf and Eddy, 2003)**

#### 4.3.1.1.3. Rotating Biological Contactors

A rotating biological contactor (RBC) is composed of a series of circular polystyrene or PVC disks that are partially submerged in a tank containing wastewater. The disks are connected by a horizontal drive shaft that slowly rotates, allowing different sections of the disks to be submerged at different times. Biomass grows on the disks, and as sections are exposed to the atmosphere, aeration is accomplished and treatment (i.e. microbial oxidation) occurs. As with trickling filters, once the biomass layer gets to a certain thickness, some dies and is sloughed into the treatment tank. The effluent is sent to secondary sedimentation, where the treated wastewater is separated from the sloughed and other settleable solids. Properly operated RBC systems can obtain BOD removal efficiencies close to those from activated sludge (Metcalf and Eddy, 2003). An examples of an RBC is shown on the following page:



**Figure 9 - Rotating Biological Contactor (Environmental Technology Centre, 2003)**

#### **4.3.1.2. Low-Rate Processes**

##### **4.3.1.2.1. Aerated Lagoons**

Aerated lagoons are similar to the activated sludge process, in that they rely on suspended growth to microorganisms in an aerobic environment to oxidize organic matter in the wastewater. They are typically constructed of earthen materials and vary in depth from 1 to 5 m (3 to 16 ft). Mechanical aerators are normally fixed on floats or platforms to provide aeration. Effluent is then sent to earthen sedimentation basins or conventional clarifiers.

There are three primary types of aerated lagoons. They include facultative partially mixed, aerobic flow through with partial mixing, and aerobic with solids recycle and nominal complete mixing. The first type only provides enough aeration to perform wastewater treatment, but not to keep all of the solids suspended. As a result, some settle into deeper, anaerobic regions of the lagoon. These lagoons eventually become stratified with an aerobic layer on top, anaerobic layer at bottom, and an intermediate zone in-between. They are referred to as facultative lagoons, since biological degradation (treatment) occurs in both aerobic and anaerobic environments. Due to the uncontrollable nature of facultative lagoons they have fallen out of

favor in recent years. In aerobic flow-through partially mixed lagoons, oxygen supplied is enough to meet treatment requirements and maintain a completely aerobic environment, but not sufficient to keep all solids in suspension. Finally, the aerobic lagoon with solids recycle is essentially identical to the activated sludge process. The environment is entirely aerobic and solids remain suspended. Further, a portion of the settled solids from the secondary sedimentation process is recycled back to the head of the lagoon (Metcalf and Eddy, 2003; USACE, 1995).

#### 4.3.1.2.2. Stabilization Ponds

Stabilization ponds are constructed in a similar manner to aerated lagoons. The primary difference, however, is that stabilization ponds do not use mechanical aeration to provide oxygen for biological treatment. Instead, they rely on oxygen produced from algae during photosynthesis. They are also characterized by long residence times, typically on the order of 10 to 50 days. There are different types of stabilization ponds, which are typically built in series. They include anaerobic or facultative oxidation ponds, high-rate ponds, algae settling ponds, and maturation ponds. The first step in the treatment process involves removal of organic matter via methanogenesis (methane formation). This is accomplished in an anaerobic environment, typically at the bottom of an anaerobic or facultative oxidation pond. Influent wastewater is discharged at the bottom of the pond to minimize dissolved oxygen intrusion and maintain an anaerobic environment. Organic matter is transformed to methane gas via biological reduction. In many cases, fermentation pits or in-pond digesters are located along the pond bottom to aid this process. Anaerobic ponds maintain a strictly anaerobic environment, while facultative oxidation ponds have three distinct layers (anaerobic, facultative, aerobic) as described in Section 4.3.1.2.1 above. High-rate ponds (HRP) are utilized in the next step. They rely on

oxygen produced by algae to remove BOD from the water. In order to keep algae in suspension and improve floc formation, paddle wheel mixers are normally installed in these ponds. Some of the biomass produced in the HRP is recycled back to the anaerobic or facultative ponds to increase removal efficiency. Once aerobic treatment is complete, some of the algae are removed in algae settling ponds to maintain low effluent nutrient concentrations. Finally, aerobic maturation ponds are used for effluent storage and to remove pathogens after biological treatment. Stabilization pond systems have been shown to reduce BOD to 15-30 mg/L, SS to 15-40 mg/L and 3-6 orders of magnitude for pathogens. They are also effective in removing nitrogen, and to a lesser extent, phosphorous. However, chemical addition in the HRP stage is often required to obtain acceptable removal efficiencies without any further treatment. (Green et al., 1995; Nurdogan et al., 1995; EPA, 1992).

#### *4.3.2. Secondary Sedimentation*

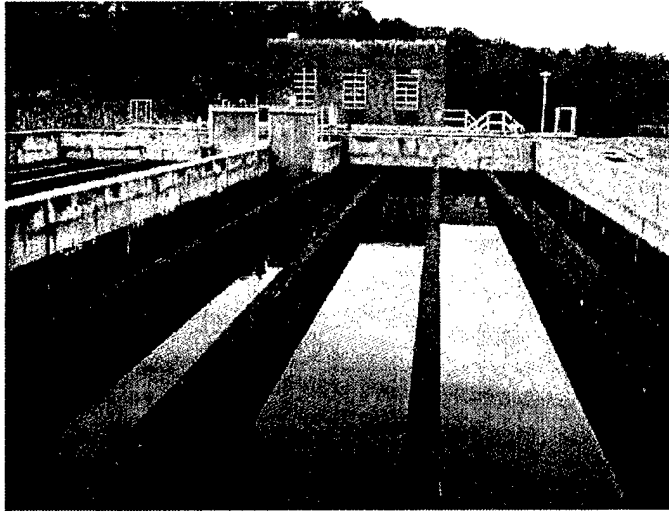
Secondary sedimentation normally follows all aerobic biological treatment processes described previously, and functions in the same manner as primary sedimentation facilities. During biological treatment, additional settleable solids are created and must be removed. BOD, COD, some heavy metals, and organic compounds can be significantly reduced after biological treatment and secondary sedimentation have occurred (EPA, 1992).

#### 4.4. ADVANCED TREATMENT

Advanced treatment is a general treatment category involving high-efficiency and specialized processes designed to reduce specific contaminants to extremely low levels in order to meet permit or process requirements. The most common form of advanced treatment is disinfection, which is employed by most domestic wastewater treatment plants before discharging their effluent into surface water bodies. Advanced treatment processes can often be expensive require considerable maintenance to ensure continued process efficiency. However, they can produce very high quality effluents designed to be used in a myriad of applications. Some of the most common forms of advanced treatment, specifically those employed in water reuse projects, are described below.

##### *4.4.1. Disinfection*

The purpose of disinfection is to reduce pathogen concentrations to an acceptable level (i.e. minimal risk to exposed individuals) in water used for reuse. While disinfection is not technically an advanced treatment process, it is performed after secondary treatment, and therefore can be considered separately. There are three primary types of disinfection processes used today. They include chlorination, ozonation, and ultraviolet (UV) radiation. Chlorination is by far the most popular method, due to its low cost and high effectiveness. Chlorine is added to secondary effluent in the form of chlorine gas ( $\text{Cl}_2$  (g)), sodium hypochlorite ( $\text{NaOCl}$ ), calcium hypochlorite ( $\text{Ca(OCl)}_2$ ), chlorine dioxide ( $\text{ClO}_2$ ), and in some case monochloramine ( $\text{NH}_2\text{Cl}$ ). The efficiency of disinfection and the chlorine dose required are dependent on water temperature, pH, mixing, contact time, and presence of interfering substances (such as organics and ammonia). A typical chlorine contact basin is pictured on the following page:

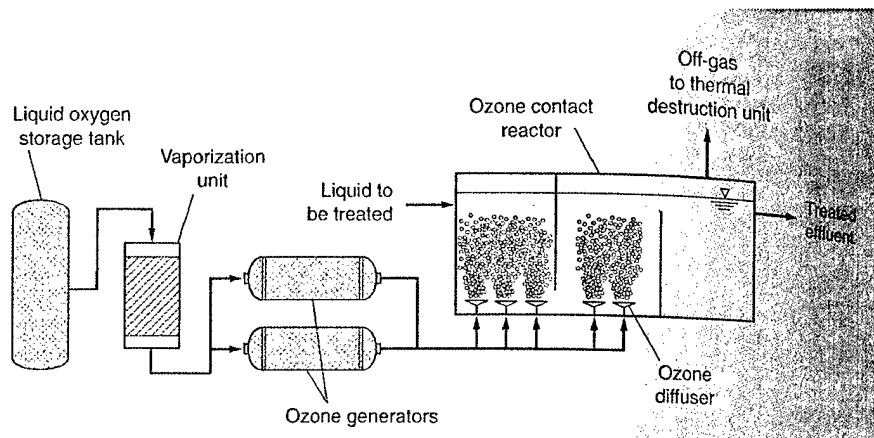


**Figure 10 - Chlorine Contact Basin (CH2M Hill, 2003)**

In many cases, it is desirable to maintain a free chlorine residual in the distribution system (i.e. irrigation piping) to prevent regrowth of microorganisms and/or pathogens that may adversely affect water quality. However, recent concerns from health risks associated with disinfection by-products have required many communities to perform dechlorination once disinfection has been completed. Dechlorination is typically done using sodium dioxide ( $\text{SO}_2$ ) or other similar reducing agents.

Ozonation is an alternative to chlorination that uses ozone ( $\text{O}_3$ ), a powerful oxidant and highly unstable form of oxygen. Ozone destroys pathogens by rapid oxidation. Through this process, ozone is reduced to oxygen ( $\text{O}_2$ ), and the dissolved oxygen concentration in the water is increased. Almost complete removal of pathogens can be achieved using ozonation. Further, it is extremely effective in removing odor and discoloration in the water. However, this process is considerably more expensive than chlorination, since the ozone must be generated on site, it is energy intensive, and requires a high degree of maintenance to keep the system functioning

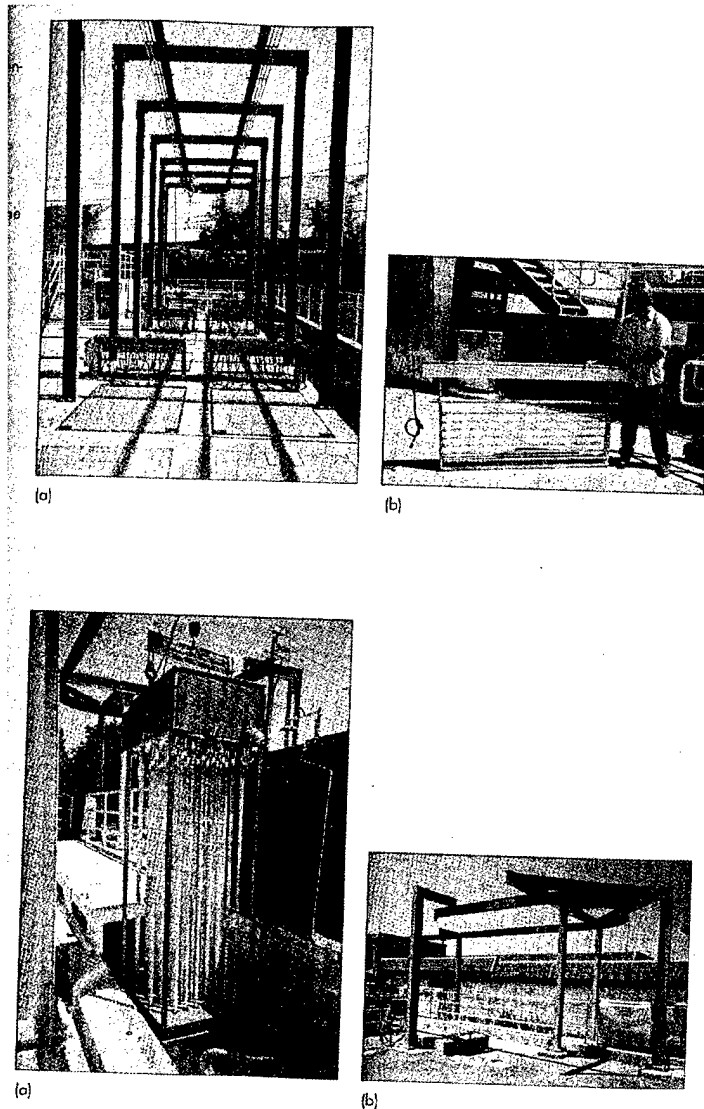
properly. The presence of interfering substances, especially oxidizable organics, can lead to decreased process efficiency. Further, a residual ozone concentration cannot be maintained in the distribution system. (Hao, 2003; Metcalf and Eddy, 2003; EPA, 1992; Noyes, 1980). A schematic of the ozonation process is shown below:



**Figure 11 - Ozonation Process Diagram (Metcalf and Eddy, 2003)**

UV radiation disinfection is accomplished by exposing water to UV radiation between 100 and 400 nm long using radiation lamps. The radiation penetrates the cell wall of microorganisms and inhibits cell reproduction and growth. Mercury-vapor lamps are used as the UV source. There are two types of lamps used; low pressure and high pressure. Low-pressure lamps operate below atmospheric pressure (in a vacuum) and produce relatively high-intensity light with a low energy requirement. High-pressure lamps operate at atmospheric pressure and have a light intensity about 10 to 20 times greater than low-pressure systems. However, they require more than 2.5 times the amount of energy. One major advantage of UV disinfection is that no toxic byproducts are formed, such as with chlorination. Further, it is a relatively simple process and does not require chemicals or associated feed equipment. However, UV disinfection effectiveness for large systems is not certain at this time. Further, as with ozonation, there is no

disinfectant residual in the distribution system. System hydraulics (i.e. changes in flow, turbulence) can also adversely impact disinfection and create variable or erratic results. Finally, as with ozonation, this is a relatively energy-intensive process (CH2M Hill, 2003; Metcalf and Eddy, 2003). Some examples of UV radiation facilities are pictured below:



**Figure 12 - Examples of UV Radiation Systems (Metcalf and Eddy, 2003)**

#### 4.4.2. Nitrification

Nitrification is the process of converting ammonia nitrogen ( $\text{NH}_4^+$ ) to nitrate nitrogen ( $\text{NO}_3^-$ ) through biological oxidation. Due to the deleterious effects of ammonia nitrogen on receiving waters and biota, it is often necessary to provide treatment involving nitrification. It is important to note that the total nitrogen concentration is not reduced during nitrification, but only its form is changed. Nitrification is normally performed using traditional suspended or attached growth processes. The activated sludge system can be modified to incorporate nitrification. This can be done in two ways. The first, and most common, is by increasing the residence time of the water in the aeration tank. Nitrifying bacteria grow much slower than heterotrophic (carbon-oxidizing) bacteria, and therefore require a much longer time to perform their function. If traditional residence times are maintained, only BOD removal will be achieved, since the heterotrophic bacteria will dominate. The second method involves a dual-stage activated sludge process, whereby BOD removal and nitrification are achieved in different reactors. This process essentially consists of two aeration tanks and two secondary clarifiers in series. The first aeration tank has a shorter residence time for BOD removal, and the second has a longer one for nitrification. Nitrification can occur in the second stage, since most of the BOD has already been removed in the first stage.

Attached growth processes, such as rotating biological contactors and trickling filters can also be used to achieve nitrification. In both cases, separate systems for BOD removal and nitrification will have to be designed, since BOD removal dominates (as with single-stage activated sludge) with only one reactor. As before, nitrification will occur in the second system after BOD is removed (Hao, 2003; Metcalf and Eddy, 2003).

#### 4.4.3. Denitrification

Denitrification is the biological reduction of nitrate nitrogen ( $\text{NO}_3^-$ ) to nitrate gas ( $\text{N}_2(\text{g})$ ). Once nitrogen is converted to the gaseous form, it can escape into the atmosphere and reduce the overall nitrogen concentration discharged into the environment. The most common methods of denitrification involve modifications to suspended growth processes (i.e. activated sludge). Denitrification requires an electron donor, which can come in the form of influent organic matter, endogenous respiration, or an externally added carbon source (typically methanol). Denitrification process units will either be constructed before or after biological aerobic treatment facilities. They are further classified by the number of stages of sludge (solids) removal that occur. In a single-stage system, all processes (BOD removal, nitrification, denitrification) are completed before the effluent reaches a secondary clarifier. In multi-stage sludge removal, secondary clarifiers are located after each process step. For denitrification that occurs before aerobic biological treatment, the effluent from the aerobic processes is recycled to the head of the denitrification unit. The effluent (which contains  $\text{NO}_3^-$ ) along with the influent water provides the necessary conditions to promote denitrification. In addition, the tank is not aerated in order to create an anoxic environment (absence of oxygen, presence of  $\text{NO}_3^-$ ). For systems where denitrification occurs after aerobic treatment, effluent from the aerobic processes is sent directly to the denitrification unit. Denitrification occurs in the same manner as previously described. Single stage sludge removal systems can employ either the pre- or post-denitrification processes, since there is enough organic biomass in the unsettled effluent to act as an electron donor. However, multi-stage sludge removal systems typically only employ the post-denitrification system, since most of the biomass has been removed in previous steps. As such,

before the denitrification unit, organic carbon is added to facilitate the process (Hao, 2003; Metcalf and Eddy, 2003).

Another option for denitrification is the use of deep bed denitrifying filters (DBDF). These units utilize a packed bed filter to remove suspended solids and biological nitrogen. Denitrifying bacteria grow on the filter media, which is provided with an external carbon source as described for the multi-stage sludge removal systems. The media is composed of coarse, high-density sand. Filter beds are normally overlain with a gravel underdrain system. Hydraulic loading rates are typically 1 to 2 gpm/ft<sup>2</sup>, with backwash frequencies of 1 to 4 days. Effluent nitrate concentrations have been measured at or near 1 mg/L, which is significantly below most state and Federal standards. Another benefit to the DBDF technology, is that it can be used solely for suspended solids removal by ceasing external carbon source addition. This may be done during times of low reuse water demand to augment the existing treatment facilities (CH2M Hill, 2003).

#### *4.4.4. Filtration*

Filtration is typically performed after secondary biological treatment and before disinfection. In recent years, it has become extremely popular in treatment of secondary effluents and greywater, due to the significant additional contaminant removal that may be achieved. There are two primary classes of filters that can be used for treatment of water for reuse applications. They include manufactured and in-situ technologies. The former are comprised of more conventional technologies used in drinking and wastewater treatment plants, and are considered first. Conventional depth filters involve percolating a secondary effluent or greywater through a granular media bed. The bed is typically contained in a filter column or tank. Standard filtration rates range from 3-6 gpm/ft<sup>2</sup>. Solid material in the water is retained on

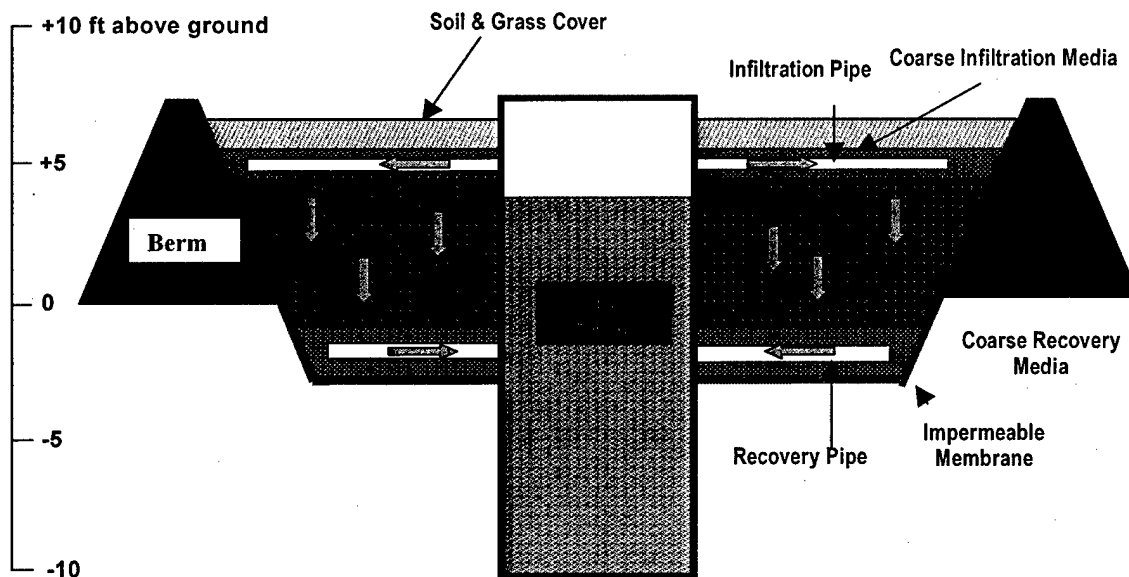
the filter media, which eventually creates significant headloss in the unit. Filters are periodically backwashed to clean the media and ensure continued process efficiency. Multiple combinations of filter media exist. They include anthracite coal and sand; activated carbon and sand; sand; anthracite, sand, and garnet; activated carbon, anthracite, and sand; and activated carbon, sand, and garnet. In multi-media filters, the smallest and heaviest media (highest specific gravity) is placed on the bottom of the filter to prevent mixing after backwash. Multi-media filters are often used, since the differently sized media are able to remove multiple contaminants better than single-media filters. (Hao, 2003; Davis, 2002; Noyes, 1980). Typical additional contaminant removals from filtration of secondary treated biological effluent are shown below:

<u>Constituent</u>	<u>Average Process Removal (%)</u>
BOD	39
COD	34
TSS	73
NH <sub>3</sub> -N	33
NO <sub>3</sub> -N	56
Phosphorous	57
Alkalinity	83
Arsenic	67
Cadmium	32
Chromium	53
Iron	56
Lead	16
Manganese	80
Mercury	33
Selenium	90
Color	31
Turbidity	71
TOC	33

**Figure 13 - Contaminant Removal Efficiencies for Filtration of Secondary Biological Effluent (Noyes, 1980)**

Some in-situ filtration techniques that can be used for reuse applications include mounded and slow-sand filters. Mounded filters are constructed just below ground surface and

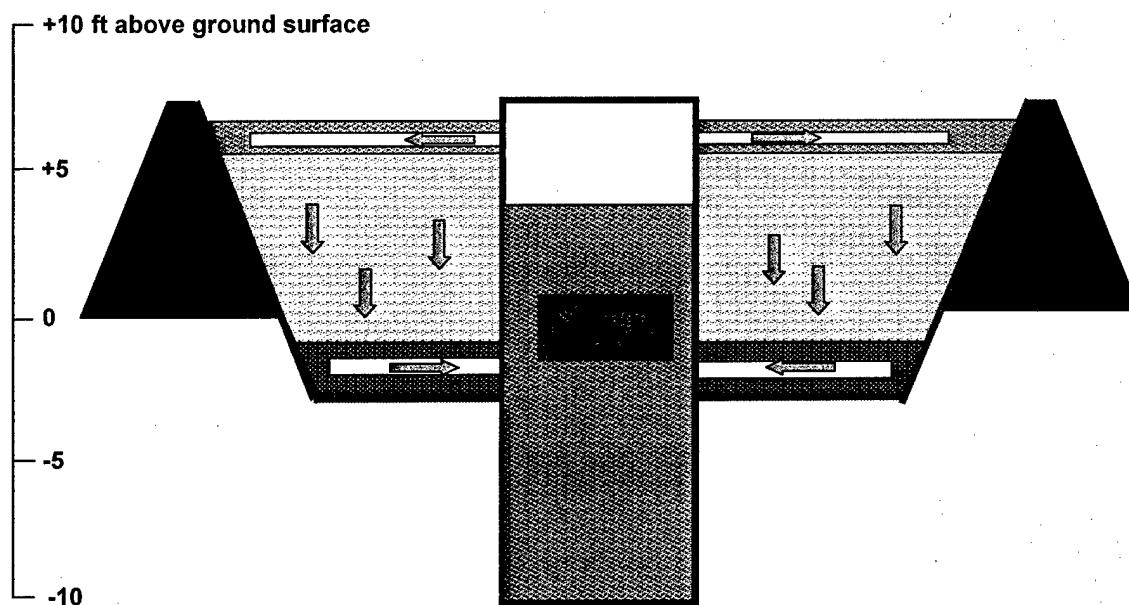
are covered by a soil and grass layer, which is separated from the filter by a geotextile fabric. Water is flooded over coarse media (i.e. gravel) using a perforated pipe. The water then percolates through progressively finer sand and gravel media for removal of suspended solids and coliforms. At the bottom of the filter, another layer of coarse media containing perforated pipes is used to channel the effluent into a concrete storage tank located at the center of the filter. The system is bounded by a berm on all sides and an impermeable membrane separates it from the native soil to prevent filtrate from entering the groundwater. A sump pump inside the filter is used to backwash the media, as required. The soil and grass cover prohibits the growth of algae on the filter surface, which would otherwise increase suspended solids buildup and reduces treatment efficiency. A schematic of the mounded filter is shown below:



**Figure 14 - Mounded Filter (CH2M Hill, 2002)**

Slow-sand filters are constructed much in the same manner as mounded filters except that there is no soil and grass cover. Further, the filter media is uniform sand, as opposed to the multiple media used in a mounded filter. Since water pools on the filter surface, algal growth can result,

leading to increased suspended solids buildup and headloss. Most of the filtration takes place on the sand surface and a filter cake will eventually form. Due to the significant solids buildup on a slow-sand filter, it requires much more cleaning than a mounded filter. Instead of using a backwashing technique, the filter is periodically shut off, drained, and the surface layer of sand scraped off and replaced. Occasionally, the entire filter sand is replaced. A diagram of a slow-sand filter is shown below (CH2M Hill, 2002):



**Figure 15 - Slow-Sand Filter (CH2M Hill, 2002)**

#### 4.4.5. Phosphorous Removal

Phosphorous removal can be accomplished through chemical and biological treatment, or by a combination of the two methods. In general, chemical methods can produce effluent phosphorous concentrations around 0.1 mg/L, where biological methods will produce between 1 to 2 mg/L. Chemical phosphorous removal involves addition of chemical coagulants to precipitate phosphorous compounds (typically poly- or orthophosphates). Common coagulants

include lime ( $\text{Ca}(\text{OH})_2$  or  $\text{CaO}$ ), alum ( $\text{Al}_2(\text{SO}_4)_3 \cdot n\text{H}_2\text{O}$ ), and ferric chloride ( $\text{FeCl}_3$ ). Lime has recently fallen out of favor, because of the large amounts of chemical sludge generated. As a result, metal salts (alum and ferric chloride) tend to be more popular. Phosphorous precipitation can occur at various points in the treatment process. Pre-precipitation involves addition of chemicals to wastewater as it enters primary sedimentation facilities. The precipitated phosphorous is then removed as part of the primary sludge. Co-precipitation occurs when phosphorus compounds are removed along with biomass solids generated during aerobic biological treatment. In this case, chemicals are added after primary sedimentation, directly to the aerobic reactor (i.e. activated sludge), or before secondary sedimentation. Finally, in post-precipitation, chemicals are added after secondary sedimentation. Here, separate facilities are constructed to coagulate and remove phosphorous. The latter option typically produces the best results, since poly-phosphorous and organic phosphorous are much more difficult to remove than ortho-phosphorous. During biological treatment, most of the phosphorous is converted to the ortho-form. As such, when post-precipitation is employed, the maximum phosphorous removal is obtained. Post-precipitation is usually conducted using a coagulation/flocculation/sedimentation treatment scheme, often followed by filtration (Metcalf and Eddy, 2003; EPA, 1992). This process is discussed in detail in Section 4.4.6.

Biological phosphorous removal operates by cultivating *Acinetobacter* (phosphorous accumulating organisms (PAO)), which uptake and store phosphorous under aerobic conditions and release it under anaerobic conditions. It is normally performed using suspended growth processes (i.e. activated sludge) with alternating anaerobic, aerobic, and/or anoxic zones. A number of processes have been developed for biological process removal. They include

anaerobic/aerobic only (A/O), anaerobic/anoxic/aerobic (A<sup>2</sup>/O), Photostrip™, and the Modified Bardenpho 5-Stage process.

The A/O process an anaerobic zone is followed by an aerobic zone, which allows for the uptake of phosphorous by the MLSS. The effluent is sent to a clarifier, where the phosphorous is removed along with the settleable solids. Some of the sludge from the clarifier is recycled back to the head of the process to maintain the biomass concentration in the reactors.

The A<sup>2</sup>/O process uses the same basic concept as A/O, except that an anoxic zone is added after the anaerobic zone for denitrification. Effluent from the aerobic zone is recycled to the head of the anoxic zone to provide nitrate nitrogen (NO<sub>3</sub><sup>-</sup>). The anoxic zone also serves to minimize the amount of nitrate nitrogen in the recycled sludge sent to the anaerobic zone. This improves phosphorous removal, since heterotrophic bacteria use nitrate nitrogen to consume organics in the anaerobic zone, leaving less "food" for the PAO.

The Photostrip™ process uses a combination of chemical and biological means to remove phosphorous. Water enters and aerobic zone, where phosphorus uptake occurs. The effluent is sent to a clarifier, where a portion of the settled sludge is sent to an anaerobic tank. Since the sludge has a high phosphorous content and anaerobic conditions exist, the phosphorous is released into solution. Some settled solids from the anaerobic tank are returned to the aerobic process, while lime is added to the supernatant to chemically precipitate the phosphorous.

Finally, the Modified Bardenpho 5-Stage process incorporates an anaerobic tank, followed by an anoxic tank, aerobic tank, anoxic tank, and finally another aerobic tank. This is a single-stage activated sludge process, similar to that described in Section 4.4.3, where the effluent from the final aerobic tank is sent to a clarifier. A portion of the settled solids is recycled back to the head of the process to maintain the MLSS concentration. This process

provides for staged nitrogen, phosphorous, and carbon (BOD) removal. In the anaerobic stage, phosphorous is released into solution. The first anoxic stage is used to denitrify nitrate nitrogen that is recycled in from the proceeding aerobic stage. As previously stated, the anoxic stage helps to improve phosphorous removal efficiency. Phosphorous uptake occurs in the aerobic stage, along with nitrification and BOD removal. Endogenous respiration (using nitrate nitrogen) for denitrification occurs in the second anoxic stage to provide additional nitrogen removal. Finally, in the second aerobic stage, remaining nitrogen gas is stripped from the water and dissolved oxygen concentration is increased in the effluent. The solids removed from the clarifier have a high phosphorous concentration (Hao, 2003; Metcalf and Eddy, 2003; EPA, 1992).

#### *4.4.6. Coagulation/Flocculation/Sedimentation*

The coagulation-flocculation-sedimentation process is performed to remove colloidal particles in the effluent from secondary or other advanced treatment processes. Coagulants such as lime ( $\text{Ca}(\text{OH})_2$  or  $\text{CaO}$ ), alum ( $\text{Al}_2(\text{SO}_4)_3 \cdot n\text{H}_2\text{O}$ ), and ferric chloride ( $\text{FeCl}_3$ ) are used to destabilize particles in solution by reducing the thickness of the electrical double layer that surrounds them. This allows attractive forces between the particles to dominate causing them to “stick” together and form larger particles (called flocs). Eventually the flocs get large enough that they settle out of solution, allowing them to be removed by sedimentation (Davis, 2002). Coagulants are available in both wet and dry form and must be blended to the appropriate strength using a chemical feed system. The first step in the process is termed rapid mixing. Here, chemicals from the feed system are blended with the water in a small tank with about a 30-second retention time. Baffles are often installed in the tank to improve mixing efficiency. The rapid mix tank is normally located directly adjacent to a flocculation basin, which is a slow mix

tank (or series of tanks) used to promote floc formation. The flocculation tank contains a series of mixers, which gently agitate the water. Three basic types of flocculation mixers exist including static, turbines/propellers, and paddles. Static mixers are impediments placed in the tank (i.e. baffles) causing flow direction to be changed or reversed. Turbine or propeller mixers use a rotating vertical or horizontal shaft with three or four blades attached. Paddle mixers are constructed of a series of vertically or horizontally mounted paddles attached to a central drive shaft. Many wastewater treatment plants employ a combination of paddle mixers with baffles to prevent short-circuiting of the flocculation process by the wastewater. The type of mixer used often depends on the contaminants being removed and type of coagulants. Further, flocculation basins can be either single- or multi-stage. For example, phosphorous removal is best accomplished through staged flocculation. In multi-stage flocculation, baffles normally separate the units and the velocity gradient is reduced in each successive basin. This allows for progressively larger particles to be formed as the wastewater travels through each basin. Variable drive speed shafts or changing the size and/or number of paddles will cause the velocity gradients to change. Once flocculation is complete, the water is sent to a sedimentation basin to remove the settled particles (Hao, 2003; Metcalf and Eddy, 2003; Envirex, 1989). Typical removal efficiencies using various types of coagulants are shown on the following page:

<u>Constituent</u>	<u>Average Process Removal (%)</u>		
	<u>Lime</u>	<u>Alum</u>	<u>Ferric Chloride</u>
BOD	65	65	62
COD	52	69	61
TSS	70	70	67
NH <sub>3</sub> -N	22	-	14
Phosphorous	91	78	71
Alkalinity	-	16	36
Oil and Grease	40	89	91
Arsenic	6	83	49
Barium	61	-	-
Cadmium	30	72	68
Chromium	56	86	87
Copper	55	86	91
Fluoride	50	44	-
Iron	87	83	43
Lead	44	90	93
Manganese	93	40	-
Mercury	0	24	18
Selenium	0	0	0
Silver	49	89	89
Zinc	78	80	72
Color	46	72	73
Foaming Agents	39	55	42
Turbidity	70	86	88
TOC	73	51	66

NOTE: "-" indicates limited or no data available.

**Figure 16 - Removal Efficiencies for Various Coagulants (EPA, 1992; Noyes, 1980)**

#### 4.4.7. Activated Carbon Adsorption

Activated carbon adsorption is one of the most efficient advanced treatment processes available. It is widely used in potable water applications as one of the final treatment steps. Its use in wastewater and reuse applications, however, is somewhat limited. The primary purpose of activated carbon adsorption is to remove biodegradable and odor-causing compounds. Up to 75 to 85 percent removal efficiency can be obtained, along with BOD effluents as low as 0.1 to 5.0 mg/L. The process of adsorption involves transfer of contaminants in the liquid phase to the

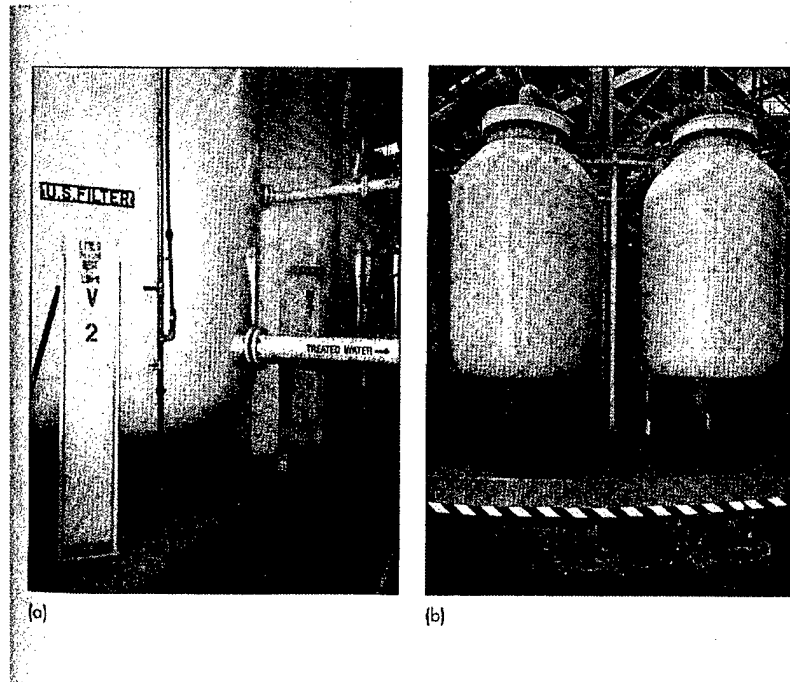
solid phase. A media (called the adsorbent) is employed to remove liquid phase contaminants (called adsorbates) and retain them on the media surface. Eventually, the media becomes saturated and must be regenerated. This can be done through a variety of chemical, physical, and even biological processes. The carbon media is termed "activated" because of its porous structure created during manufacturing. This structure provides a large surface area for contaminants to become trapped. In addition to regeneration, the carbon must occasionally be "reactivated" to remove sorbed materials from the pores.

Two types of activated carbon are normally used. They include powdered activated carbon (PAC) and granular activated carbon (GAC). The PAC has a diameter less than 0.074 mm, where the GAC has a diameter greater than 0.1 mm. Treatment with GAC requires that water be passed through a bed of activated carbon inside a reactor (often a column). The most common types of GAC units include fixed-bed columns and expanded-bed contactors. In fixed-bed columns, water is applied at the top, percolated through the carbon, and exits at the bottom. These units can be operated in series or parallel, or stand-alone. Backwashing is frequently required to reduce headloss buildup from suspended solids accumulation. In expanded-bed contactors the influent enters the system from the bottom flows upwards through the carbon bed, where it exits near the top of the contactor. This allows the bed to expand during treatment, reducing headloss buildup. When the adsorptive capacity of the carbon at the bottom of the contactor is used up, it is removed and new carbon is placed at the top of the contactor. Unlike GAC, PAC is normally added directly to a stage in the secondary treatment process or immediately after secondary treatment in a contact basin. The PAC is allowed a certain amount of time to adsorb contaminants; then it is removed by settling. In some cases, it can even be

added to the activated sludge aeration tank to help reduce odors (Metcalf and Eddy, 2003; EPA, 1992).

#### *4.4.8. Ion Exchange*

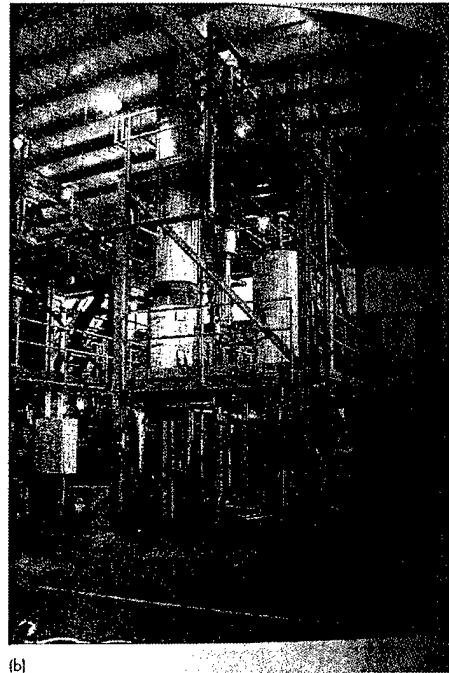
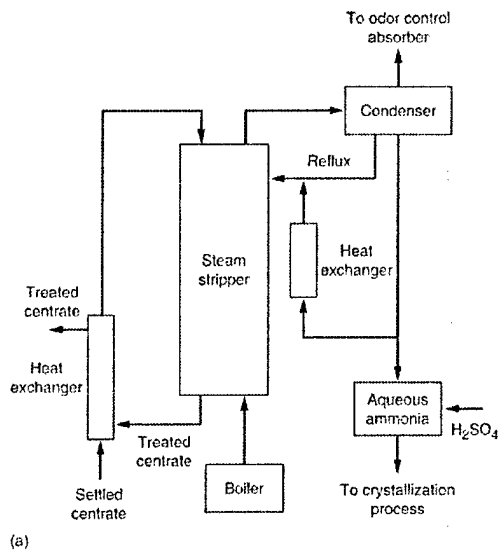
Ion exchange operates on the principle of displacement of contaminants in solution as water comes into contact with a resin containing oppositely charged ions. The contaminants (which are charged) adsorb onto the resin. To maintain electroneutrality in the water, ions in the resin that have similar charges to the contaminants will enter the solution. Ion exchangers are classified as either cation or anion exchangers. Cation exchangers use negatively charged resins, while anion exchangers use positively charged resins. Cation exchangers are the most widely used application. They use resins containing strong or weak acids, which displace hydrogen ions when positively charged contaminants become adsorbed. Anion exchangers use resins with hydroxide (strong base) or non-protonated nitrogen (weak-base) to attract negatively charged contaminants. Another technology, which is used primarily for heavy metals removal is called chelating cation exchange. They rely on Lewis acid and base affinity between heavy metal ions (positively charged) and O<sup>-</sup>, N<sup>-</sup>, and S<sup>-</sup> containing ligands, which are contained in the resin. Lewis acids are ions that have incomplete outer electron shells and act as good electron acceptors. Most heavy metals are good Lewis acids. Lewis bases have an extra electron pair in their outer shell, which can be easily donated to a Lewis acid. Ion exchangers are normally operated in packed-bed columns, where the influent enters at the top and exits at the bottom. When the exchange capacity has been exhausted, the system is backwashed to remove suspended solids and regenerated (Metcalf and Eddy, 2003; Malkin, 2002). A typical ion exchange unit is shown on the following page:



**Figure 17 - Typical Ion Exchanger (Metcalf and Eddy, 2003)**

#### *4.4.9. Ammonia Stripping*

Ammonia stripping is used to remove ammonia nitrogen ( $\text{NH}_4^+$ ) from water. When the pH of water is raised to around 11, all of the ammonia is converted to the gaseous form ( $\text{NH}_3$  (g)). The water is then passed through a “stripping” tower, where it is contacted with air flowing countercurrent to the water. The ammonia gas volatilizes and is removed in the air as it exits the tower. This process is highly dependent on temperature of the outside air, since at low temperatures solubility of the ammonia significantly increases and removal is poor. At optimum pH and temperature conditions, up to 98% removal of ammonia gas can be obtained (Noyes, 1980). A schematic of the ammonia stripping process is shown on the following page:



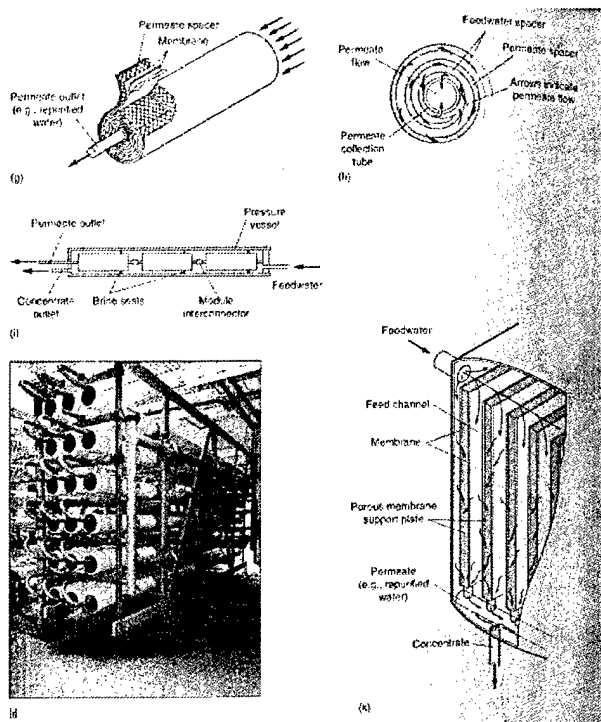
**Figure 18 - Ammonia Stripping Process (Metcalf and Eddy, 2003)**

#### 4.4.10. Membrane Processes

Membrane filtration has been around for many years, but applications are limited due to the high costs and operational problems associated with these systems. However, membrane processes have been shown to exhibit extremely high removal efficiencies when optimal conditions exist. The types of membrane processes include microfiltration (MF), ultrafiltration (UF), nanofiltration (NF), reverse osmosis (RO), and electrodialysis (ED). Membranes are composed of a thin skin layer about 0.2 to 0.25  $\mu\text{m}$  thick and surrounded by a porous structure about 100  $\mu\text{m}$  thick. Organic-based materials, such as cellulose, polypropylene, and acetate are commonly used for wastewater and greywater treatment. Microfiltration and ultrafiltration are accomplished primarily by retaining solids on one side of the membrane as the cleaner water passes through the pores. Nanofiltration uses a similar concept, but also relies on a layer of water molecules formed on the membrane surface that prohibits small particles from passing

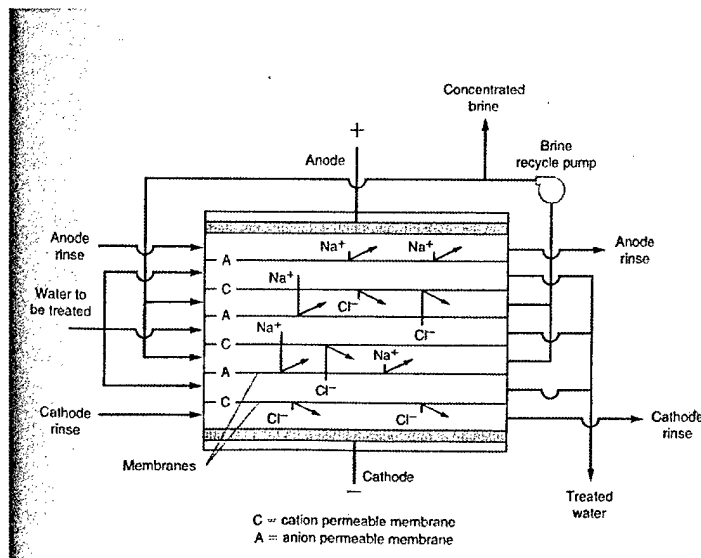
through. The main difference between MF, UF, and NF technologies is the membrane pore size. MF has the largest pores ( $> 50 \text{ nm}$ ), while NF has the smallest ones ( $< 2 \text{ nm}$ ).

Reverse osmosis utilizes a semi-permeable membrane that separates two solutions (i.e. treated and untreated water) with different compositions. Naturally, water with a higher chemical potential (lower concentration) will want to diffuse to the side of the membrane with lower chemical potential (higher concentration). The equilibrium that is reached between the two sides is called osmotic pressure (more technically, it the pressure on the more concentrated side that is required to prevent diffusion from the less concentrated side). Reverse osmosis operates on the principle that if a pressure is applied to the more concentrated side which is greater than the osmotic pressure, flow will actually occur in the opposite direction (towards the less concentrated side). A typical reverse osmosis unit is shown below:



**Figure 19 - Reverse Osmosis Unit (Metcalf and Eddy, 2003)**

Finally, electrodialysis uses a semi-permeable membrane to separate ions from solution. Electrical current is passed through the water, which causes cations to migrate towards the negative electrode and anions to the positive electrode. Alternating cation and anion permeable membranes are set up to create regions of concentrated and dilute salt solutions. As previously stated, membrane processes can encounter major operational problems due to the buildup of suspended solids on the membrane skin. The effective size of the pores can be reduced or even closed and caking can occur between the pores due to differences in concentration. Backwashing membrane filters, chemical cleaning, and pretreatment are options to reduce or eliminate some of these problems (Metcalf and Eddy, 2003). A diagram of the electrodialysis process is shown in Figure 20 below:



**Figure 20 - Electrodialysis Process (Metcalf and Eddy, 2003)**

## 4.5. LAND APPLICATIONS

### *4.5.1. Land Treatment*

The U.S. Army Corps of Engineers defines land treatment to be “controlled application of wastewater onto the land surface to achieve a designed degree of treatment through natural physical, chemical, and biological processes within the plant-soil-water matrix” (USACE, 1982).

Land treatment is an alternative to conventional municipal water treatment processes.

Depending on the characteristics of the water intended for reuse, land treatment may be a viable alternative. Land treatment is typically grouped into three categories; slow rate (SR), rapid infiltration (RI), and overland flow (OF). Average water quality using each application is summarized below (USACE, 1982):

<u>Constituent</u>	<u>Slow Rate</u>	<u>Average Water Quality</u>	
		<u>Rapid Infiltration</u>	<u>Overland Flow</u>
BOD	2 – 5 mg/L	5 – 10 mg/L	10 – 15 mg/L
TSS	1 – 5 mg/L	2 – 5 mg/L	10 – 20 mg/L
NH <sub>3</sub> -N	0.5 – 2 mg/L	0.5 – 2 mg/L	4 – 8 mg/L
TN	3 – 8 mg/L	10 – 20 mg/L	5 – 10 mg/L
Phosphorous (as P)	0.1 – 0.3 mg/L	1 – 5 mg/L	4 – 6 mg/L
Fecal Coliforms	0 – 10 per 100 mL	10 – 200 per 100 mL	200 – 2000 per 100 mL

**Figure 21 - Average Water Quality from Land Treatment of Municipal Wastewater (USACE, 1982)**

#### **4.5.1.1. Slow Rate (SR)**

Slow rate (SR) land treatment is when water is discharged to vegetated land surfaces either through sprinklers or surface application. Some of the water is used by vegetation, while the rest infiltrates the groundwater table. As the water flows through the vegetation and underlying soil, contaminants are removed. Application rates are adjusted to prevent surface

runoff. A major advantage of SR systems is that they replace the need to use potable water for irrigation. As such, substantial water use reductions can be implemented for agricultural land, grassy areas, golf courses, parks, and other areas requiring large amounts of water. The major disadvantage of SR systems is that they often do not produce BOD and nutrient removals high enough to meet EPA or state drinking water regulations for ground water quality. Nitrogen removal is often the primary concern, since many states have strict limits for nitrogen discharge to groundwater. Sufficient nitrogen removal cannot normally be obtained through SR treatment, and consequently either the hydraulic loading of reclaimed water must be curtailed or this option is disregarded entirely for fear of non-compliance (USACE, 1982).

#### **4.5.1.2. Rapid Infiltration (RI)**

Rapid infiltration (RI) involves the use of surface basins to collect and distribute water through moderately or highly permeable soils. As in SR treatment, contaminants are removed as the water percolates through the ground. RI differs from SR treatment in that most of the water percolates to the groundwater table and there is little use by plants. In fact, most areas where RI systems are employed have little or no vegetative cover. Further, water in the basins will often drain naturally to nearby surface water bodies. This method is often used for groundwater recharge applications or if storage of water in temporary aquifers, wells, or underdrains is desired for later use.

A potential application for non-potable water reuse involves creation of a man-made aquifer to treat and store water for later use. One method developed by CH2M Hill involves percolating secondary effluent through a soil matrix into a shallow aquifer. A buried perforated pipe is used for extracting water from the aquifer, which is then stored in a tank for use as irrigation water. The type of native soil, location (relative depth) of other aquifers, and treatment

efficiency are major factors to be considered when implementing RI systems. Nitrogen removal is often a limiting factor, similar to SR systems. Successful implementation strongly relies on the quality of the influent, regulatory limits, and site stratigraphy (CH2M Hill, 2002; USACE, 1982).

#### **4.5.1.3. Overland Flow (OF)**

In overland flow (OF) water is introduced at the top of a vegetated sloped surface via pipes or surface trenches and allowed to flow into runoff collection ditches in lower-lying areas. Once water is collected, it may be recycled through the system again, discharged to surface water bodies, or used for land application. Unlike SR and RI systems, impermeable soils are best for this type of treatment, since contaminant removal occurs as the water passes over land, instead of through the soil matrix. This process is also effective in moderately permeable soils with impermeable underlying strata (MDE, 2002; USACE, 1982).

#### *4.5.2. Constructed Wetlands*

Constructed wetlands are a natural treatment process using man-made wetlands at locations where naturally occurring wetlands did not previously exist. Since they are considered a treatment process and not a "receiving water" under the Clean Water Act, they are exempt from related discharge regulations. Water flows into the wetland and is naturally treated by biota (mainly indigenous wetland plants) to remove contaminants. Plants filter contaminants and provide a growth surface for bacteria, while the root zone facilitates oxidation of organic material, since it is an aerobic environment. Two primary types of constructed wetlands exist. They are termed surface flow (SF) and subsurface flow (SSF). In SF systems, aquatic vegetation grows above the water surface in a shallow bed or channel. As water flows through the wetland it is exposed to the atmosphere. In a SSF system, vegetation grows in a permeable stratum such

as rock, gravel, sand, or soil. Water flows underground, just below the surface. Constructed wetlands can often provide up to 80% removal of BOD, suspended solids, phosphorous, trace heavy metals, and other trace organic compounds (USACE, 1995).

## **5. INDUSTRIAL USES**

Industrial water use accounts for a significant fraction of potable water consumption on U.S. Navy Bases. While not all applications lend themselves to water reuse, many of them do. This section considers the most likely processes where water reuse initiatives can be implemented with little or no impact on operational effectiveness. Industrial applications considered include: (1) Vehicle and Aircraft Washing Facilities, (2) Plating Operations, (3) Metal Cleaning Facilities, (4) Industrial Laundry Facilities, and (5) Cooling Systems

### **5.1. VEHICLE AND AIRCRAFT WASHING FACILITIES**

The Navy maintains over 1,200 washrack facilities for cleaning of tactical/tracked vehicles, automobiles, and aircraft. They are generally categorized as follows:

- Aircraft Washrack Pavement
- Aircraft Rinsing Facility
- Aircraft Fire and Rescue Station
- Combined Structural/Aircraft Fire and Rescue Station
- Landing Craft Washrack
- Amphibian Vehicle Maintenance Shop
- Combat Vehicle Maintenance Shop
- Automotive Vehicle Maintenance Shop
- Vehicle Washing Platform

These facilities are further classified by the quality and composition of washwater effluent.

Characteristics of each type of facility are shown on the following page:

<u>Facility Type</u>	<u>Water Required (gal)</u>	<u>Washwater Effluent (gal)</u>
Aircraft Rinsing	1000 – 3000	1750 (average)
Aircraft Washrack Platform	200 (helicopter) 2500 – 3000 (aircraft)	2000 (average)
Automotive Washrack	100 – 1000	200 – 1000 (average)
Tracked Vehicle Washrack	1000 – 3000	2000
Automotive Vehicle Maintenance	100 – 1000	200 – 1000 (average)

**Figure 22 - Typical Characteristics of Vehicle and Aircraft Washing Facilities (NFESC, 1993)**

As evidenced from the table above, aircraft washing typically consumes the most water. Further, aircraft are normally washed more frequently (i.e. once per week) than automobiles or track vehicles, so their overall water use is usually the highest. Contaminants in the washwater effluent include oils, grease, dirt, salt, paint, detergents, solvents, strippers, and numerous other cleaning chemicals.

#### *5.1.1. Water Quality Requirements*

In order to prevent damage to the washrack equipment or vehicles/aircraft being washed, reclaimed water should meet the following quality standards:

<u>Constituent</u>	<u>Concentration (mg/L)</u>
NH <sub>4</sub> <sup>+</sup>	15
BOD	20
Chlorine	300
COD	100
Cyanide	0.5
Iron	40
Oil and Grease	5
Phenol	3
Sodium	300
TSS	60
Alkalinity (as CaCO <sub>3</sub> )	300
TDS	100

**Figure 23 - Recommended Water Quality Standards for Vehicle and Aircraft Washing Facilities (NFESC, 1993)**

In many cases, this will require treatment of the washwater effluent before it can be reused.

Treatment options are discussed in Section 5.1.3.

#### *5.1.2. Potential Water Sources*

Multiple options exist for washrack water sources. Secondary municipal effluent may normally be used with proper treatment. Another option is to use water collected from cooling tower blowdown (this is described in Section 5.5.). Finally, a recycling scheme can be constructed to collect washwater effluent, treat it, and return it to the washrack for reuse. If secondary effluent is used, it is preferable to incorporate advanced treatment requirements into existing wastewater treatment facilities, instead of constructing an on-site system. Due to the regular availability of secondary effluent, this may often be the best source for washrack facilities. Normally, it is not practical to incorporate secondary effluent into an on-site recycling system due to associated specialized treatment and monitoring requirements. It is more reasonable to treat it at the plant where proper facilities and expertise are available. In many cases, water treated for other reuse applications (i.e. irrigation) can also be used for washracks.

If on-site recycling is desired, land requirements, construction costs, and operating costs will need to be considered.

### *5.1.3. Treatment*

The type(s) of treatment required for washrack water reuse applications depends on system configuration and the water source. For purposes of discussion, washrack reuse systems are classified as follows:

- Secondary Effluent Reuse – Additional treatment occurs at the wastewater treatment plant. Water is piped and/or pumped to the washrack site. Washwater effluent is disposed to the domestic sewer system.
- Cooling Tower Blowdown Reuse – Blowdown water is collected from the cooling towers. It is piped and/or pumped to the washrack site for treatment. On-site reclamation facilities can be modified to incorporate cooling tower blowdown.
- On-Site Reclamation – Washwater effluent is collected and treated on-site, then recycled back for reuse.

Each of these options is considered below:

#### **5.1.3.1. Secondary Effluent Reuse**

Secondary municipal effluent will typically meet most of the water quality requirements listed above. However, the major concern when using secondary effluent is pathogen and microorganism removal. It is imperative that washrack users are not subject to unhealthy levels of disease-causing organisms. In order to improve the quality of the effluent, filtration using sand, activated carbon, or a combination of the two can be employed to further reduce suspended solids and remove microorganisms. Additional disinfection will likely be required to minimize

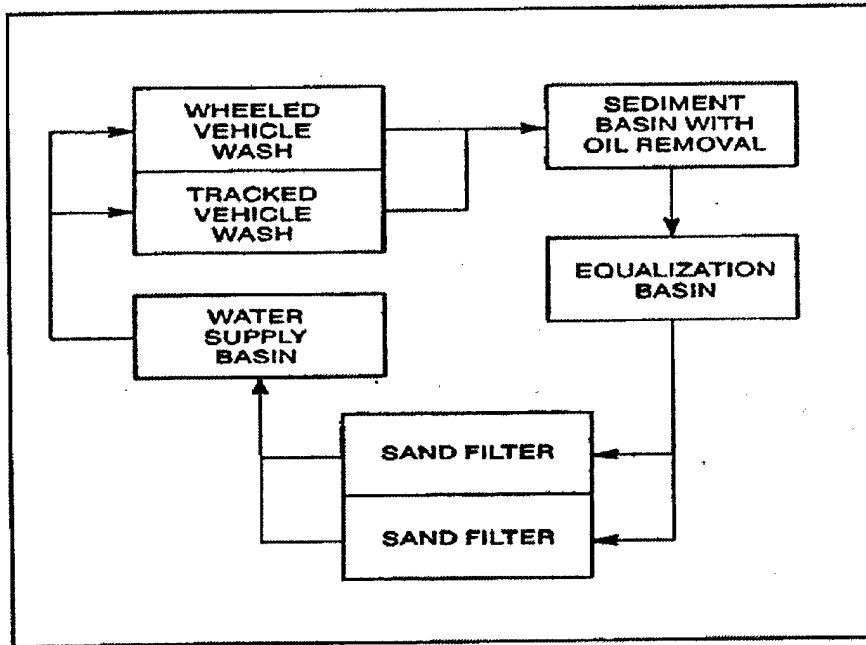
health risks. Since chlorine can damage aircraft and vehicle surfaces due to its strong oxidizing properties, UV radiation is the best method of disinfection for washrack applications.

#### **5.1.3.2. On-Site Reclamation**

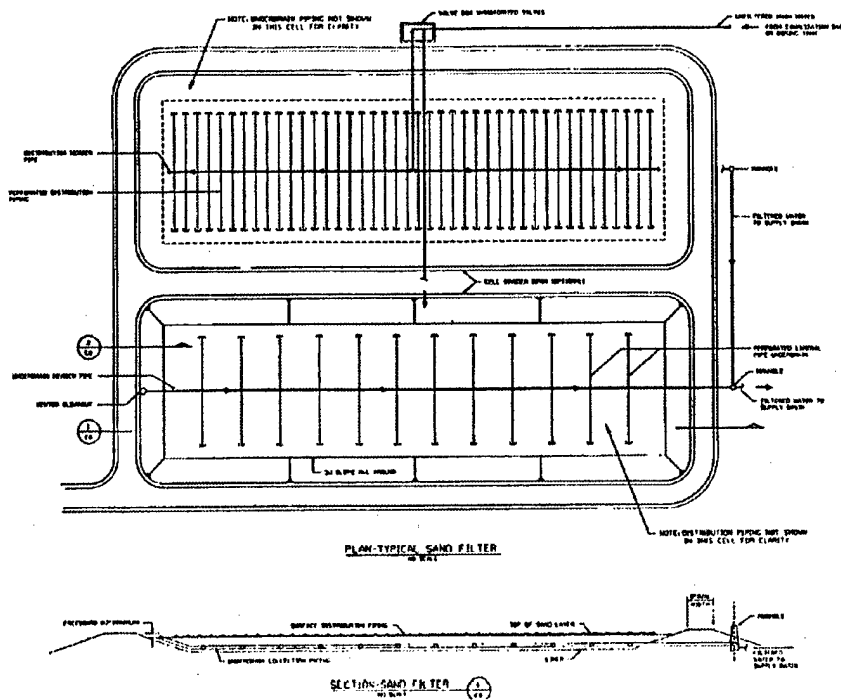
The U.S. Army Corps of Engineers has developed three types of on-site reclamation facilities for their central vehicle wash facilities. They include: (1) intermittent sand filtration, (2) lagoons, and (3) constructed wetlands. Each system has been shown to provide high quality effluent with minimal operator maintenance. These systems are described below in general terms. More specific guidance concerning construction and design can be found in ETL 1110-3-469, published by the U.S. Army Corps of Engineers.

##### **5.1.3.2.1. Intermittent Sand Filtration**

The intermittent sand filtration system initially uses sedimentation to remove settleable solids and floating oil and grease. The effluent is then sent to an equalization basin. Next, the water is flooded over a series of sand filters at pre-defined intervals. The intermittent flooding allows the filter surfaces completely drain before the next application. Filtrate is collected in a water supply basin, which is used for subsequent vehicle washing. Suspended solids, nitrogen, and algae removal can be achieved using this system. The intermittent sand filtration system requires a considerable land area and specific types of sand to be effective. Depending on the location and layout of the base, these factors may pose problems. A typical flow diagram using the intermittent sand filtration system along with a detailed plan view of a typical sand filter are shown on the following page:



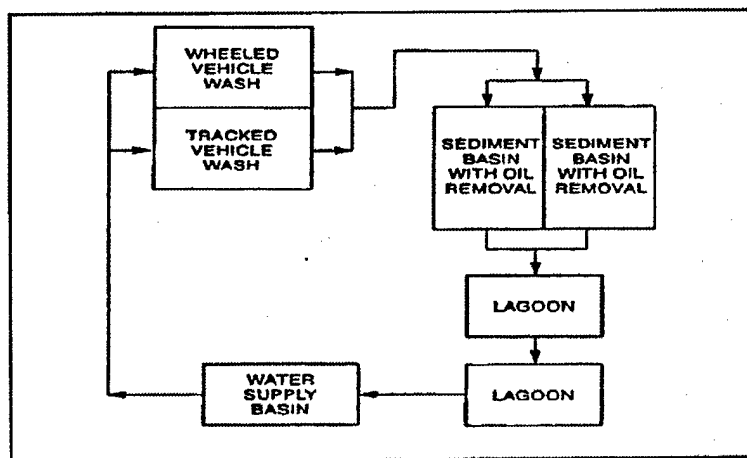
**Figure 24 - Process Diagram for Intermittent Sand Filtration (USACE, 1995)**



**Figure 25 - Typical Intermittent Sand Filter System (USACE, 1995)**

### 5.1.3.2.2. Lagoons

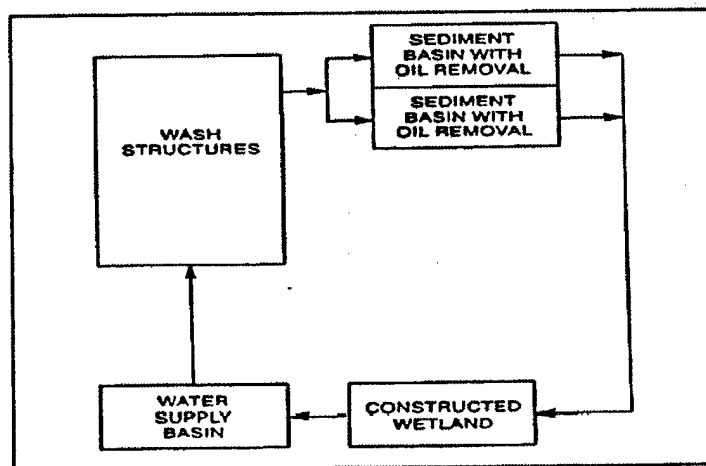
The lagoon system incorporates a series of two or three aerated lagoons like those described in Section 4.3.1. They are normally operated in series to provide optimum performance. The first lagoon is often used as an equalization basin located directly after sedimentation. After lagoon treatment, the water is sent to a supply basin for reuse, similar to the intermittent sand filtration system. High levels of BOD, COD, and suspended solids removal can be achieved using these systems. Generally, the system is designed for a 14-day retention time at peak flow conditions. Floating baffles can be used to control retention time and flow through the lagoons. Lagoons should be lined to prevent seepage into the groundwater table. A major advantage of lagoon-based systems is that they require little or no operator training. Other than periodic checking for blocked inlets and outlets, they more or less operate independently. However, as with intermittent sand filters, a large land area is required to support a lagoon system. Further, algae blooms and habitation by birds and aquatic animals may degrade water quality. The serviceable life of a lagoon-based treatment system is estimated at 15 to 20 years. A typical flow diagram is shown below (USACE, 1995):



**Figure 25 - Process Diagram for Lagoon Washwater Treatment System (USACE, 1995)**

### 5.1.3.2.3. Constructed Wetlands

Use of constructed wetlands for washwater effluent treatment is yet another viable option. After sedimentation, the water enters the constructed wetland, where BOD, suspended solids, phosphorous, trace metals, and trace organics are removed. Constructed wetland use was described previously in Section 4.5.2. In order to achieve high suspended solids removal, a system retention time of between 2 to 7 days is required. A single wetland cell can be used or multiple cells in parallel or series can be employed. After treatment, the water is collected in a supply basin for reuse, as with the other two systems. As with lagoon systems, constructed wetlands must be lined to prevent groundwater infiltration. Minimal operator maintenance is required for constructed wetlands, but they too take up a considerable amount of space. Further, surface flow wetlands can be a breeding ground for mosquitoes, other insects and disease vectors. Further, insect infestation can lead to destruction of wetland vegetation and decrease treatment efficiency. Provisions for pest control must be included if a constructed wetland configuration is used. Further, in cold climates the vegetation may not be as viable during winter months as in warmer periods. A typical flow diagram is shown below (USACE, 1995):



**Figure 26 - Process Diagram for Constructed Wetland Treatment System (USACE, 1995)**

### **5.1.3.3. Cooling Tower Blowdown Reuse**

Blowdown water from cooling towers typically requires minimal treatment before it can be used in washracks. Suspended solids and salt content are the only significant contaminants that must be removed. If an on-site reclamation system is planned or already in place, the blowdown water can be piped to the sedimentation basin and mixed with the washwater effluent. Another option is to use sand filtration to remove suspended solids and pump the effluent to a storage tank for washrack use. Depending on the size and number of cooling towers used on a base, blowdown water quantities may not be sufficient to meet washrack water demand. As such, it may need to be augmented by the potable water supply. However, even with this configuration, potable water consumption will be reduced.

## **5.2. PLATING OPERATIONS**

Plating involves application of a surface coating to an item in order to provide corrosion resistance, wear resistance, or for decoration. The U.S. Navy operates plating shops on a number of bases, which perform hard chrome plating, nickel, zinc, or cadmium plating, etching, and phosphating, to name a few. There are three basic steps in the plating process; surface preparation, plating, and post-treatment. After each step, rinsing is conducted to remove any residue from the prior step. Virtually all of the water used in plating operations is during the rinsing step (NFESC, 1993).

### 5.2.1. Water Quality Requirements

Rinse water used in the plating process must meet the following water quality standards:

<u>Constituent</u>	<u>Concentration (mg/L)</u>
NH <sub>4</sub> <sup>+</sup>	0.5
Arsenic	0.05
BOD	1
Boron	1
Cadmium	0.01
Chromium	0.05
COD	3
Copper	1
Cyanide	0.2
Hardness (as CaCO <sub>3</sub> )	10
HCO <sub>3</sub> <sup>-</sup>	5
Iron	0.3
Lead	0.05
Manganese	0.05
NO <sub>3</sub> <sup>-</sup>	10
Phenol	0.001
Sulfate (SO <sub>4</sub> <sup>-2</sup> )	5
TSS	1
TDS	250
Zinc	5

**Figure 27 - Water Quality Requirements for Plating Rinse Water (NFESC, 1993)**

### 5.2.2. Reuse Alternatives

Two primary alternatives exist for reuse of water for rinsing processes. They include recycling the rinse water without any further treatment, or reclamation that involves treating the used rinse water then reusing it in the plating process.

#### 5.2.2.1. Recycling

The technique used to recycle rinse water is termed "reactive rinsing". There are two ways to implement reactive rinsing, namely intraprocess or interprocess. Intraprocess reactive rinsing involves using the rinsewater from a previous step again in the next step. Instead of using fresh water in each rinse tank, multiple tanks are used that contain the discharge from the

prior step. After all steps are completed, the water is discharged. As long as there are no harmful chemical interactions (i.e. between chemicals used for each step or harmful to the process), this method can significantly reduce the amount of fresh water required for rinsing. The interprocess method can be used when multiple plating operations are occurring. Here, instead of having separate freshwater inputs to each rinse tank, rinse water from one process is reused in the rinse tanks of another process (NFESC, 1993).

#### **5.2.2.2. Reclamation**

In order to produce rinse water that is high enough in quality to be used at the start or throughout the plating process, chemical contaminants must be removed to the levels indicated in Section 5.2.1. To do this, multiple advanced treatment processes may be required. As a first step, the spent rinse water should be filtered using sand or activated carbon to remove suspended solids. Next, either membrane processes, such as reverse osmosis and electrodialysis, or ion exchange should be used to remove low-level contaminants. Another option is to separate the clean rinsewater by evaporation. However, unless the solution is highly contaminated, this option may be costly (due to energy requirements) and ineffective (NFESC, 1993).

### **5.3. METAL CLEANING FACILITIES**

Metal cleaning facilities clean and prepare metal parts to ensure they perform correctly in their respective applications. Chemicals are used to remove dirt, grease, rust, or other impurities from metallic surfaces. The cleaning chemicals can be solvents, acids, detergents, or alkaline-based. After metal cleaning has been performed, the parts are rinsed either by spraying or submerging the parts in a rinse tank. Aircraft repair facilities, electroplating facilities, machine

shops, paint shops, and shipbuilding facilities all incorporate some form of metal cleaning (NFESC, 1993).

### 5.3.1. Water Quality Requirements

Water used for rinsing processes in metal cleaning facilities should meet the following quality standards:

<u>Constituent</u>	<u>Concentration (mg/L)</u>
NH <sub>4</sub> <sup>+</sup>	0.5
Arsenic	0.05
BOD	1
Boron	1
Cadmium	0.01
Chromium	0.05
COD	3
Copper	1
Cyanide	0.2
Hardness (as CaCO <sub>3</sub> )	10
HCO <sub>3</sub> <sup>-</sup>	5
Iron	0.3
Lead	0.05
Manganese	0.05
NO <sub>3</sub> <sup>-</sup>	10
Oil and Grease	5
Phenol	0.001
Sulfate (SO <sub>4</sub> <sup>-2</sup> )	5
TSS	1
TDS	250
Zinc	5

**Figure 28 - Water Quality Requirements for Metal Cleaning Rinse Water (NFESC, 1993)**

### 5.3.2. Reuse Alternatives

Metal cleaning rinse water can be reused in the same manner as for metal plating facilities. In addition, cooling tower blowdown water will typically meet the quality standards set forth above without requiring any additional treatment. Consequently, it provides an extremely attractive alternative to using potable water if sufficient quantities exist. If a

reclamation system is used, remediation of metal cleaning solutions contaminated with organic solvents may be a complicating factor. In these cases, pretreatment with sand filtration followed by activated carbon adsorption and/or ion exchange may need to be used (NFESC, 1993).

#### 5.4. INDUSTRIAL LAUNDRY FACILITIES

Industrial laundry facilities are present on every Navy installation in some form. Bachelor housing facilities use them to wash linens for transient personnel and to provide personal laundry facilities for residents. Commercially operated laundromats are available for use by base personnel for self-service and/or paid clothes washing. Other facilities use them to wash dirty uniforms, rags, and other linens used during the workday. Most of the machines used are large front-loading, horizontal-axis washers, which are not typically found in residential homes (NFESC, 1993).

##### *5.4.1. Water Quality Requirements*

Before washwater effluent can be reused, it must be treated meet the following requirements for the chemical composition of laundry water. Used rinse water will normally meet most of these criteria with minimal or no treatment.

<u>Constituent</u>	<u>Concentration (mg/L)</u>
Benzene	0.1
BOD	30
Chloroform	0.1
Chromium	0.1
COD	100
Copper	0.1
Lead	0.1
Nickel	0.1
Oil and Grease	10
Perchloroethylene	0.1
TSS	Below Detection Limits
Toluene	0.1
Zinc	0.1
Color	Below Detection Limits
Hardness (as CaCO <sub>3</sub> )	50
Odor	Below Detection Limits
PH	7 – 8
TDS	2,000

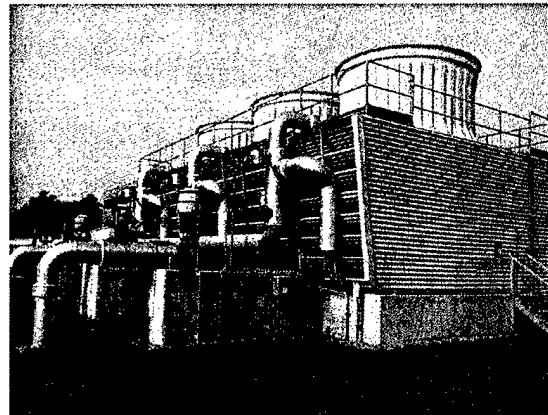
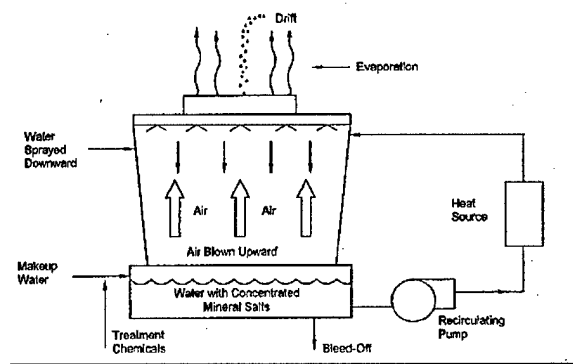
**Figure 29 - Water Quality Requirements for Industrial Laundry Facilities (NFESC, 1993)**

#### *5.4.2. Reuse Alternatives*

Rinse water can often be reused in subsequent wash cycles. Normally, some fresh water is added to ensure adequate water quality. In some cases filtration is required to remove lint or suspended solids before reuse. Washwater effluent must typically undergo some form of chemical addition or adsorption treatment before it can be reused. Often, filtration is incorporated as a pre-or post-treatment step to remove suspended solids. Common chemical treatments include the use of coagulants, such as alum or ferric chloride, to precipitate contaminants. However, the sludge formed must then be removed and treated or disposed of. A common adsorption method involves filtration with activated carbon (NFESC, 1993).

## 5.5. COOLING SYSTEMS

Cooling systems typically have the highest water demand of industrial uses on a base. As such, they are most common application targeted for water reuse. Two primary types of cooling systems exist recirculating and once through cooling systems. Recirculating systems use water to absorb heat, release the heat by evaporation, and use the water again for additional cooling cycles. The most common type of recirculating system is the cooling tower. Cooling tower operation involves introducing dry air through the sides or bottom of the tower, while water is pumped to the top of the tower. When the water and air come into contact, some of the water will evaporate. The remaining water collects at the bottom of the tower for future use. Evaporation and wind action (called drift) cause the total amount of water in the tower to be reduced to an extent that some must be replaced on a continuing basis. Further, a portion of the recirculated water is wasted to prevent salt buildup in the tower. Relatively high-quality water is required in cooling towers, since contaminant concentrations are increased after each cooling cycle, due to pure water loss. Figure 30 depicts the typical operation of a cooling tower:



**Figure 30 - Typical Cooling Tower (NFESC, 1993)**

Once-through cooling systems use water to cool equipment, and then discharge it after only one use. They are used for evaporative coolers, icemakers, hydraulic equipment, and air compressors. Since they are extremely inefficient (i.e. they only use the water once) and can use up to 100 times as much water as recirculating systems, they are not normally good candidates for water reuse (NFESC, 1993; EPA, 1992).

### 5.5.1. Water Quality Requirements

The U.S. Environmental Protection Agency (EPA) recommends that water used in recirculating cooling systems meets the following criteria (EPA, 1992):

<u>Constituent</u>	<u>Concentration (mg/L)</u>
Chlorine	500
TDS	500
Hardness (as CaCO <sub>3</sub> )	650
Alkalinity (as CaCO <sub>3</sub> )	350
PH	6.9 – 9.0
COD	75
TSS	100
Turbidity	50
BOD	25
Organics	1.0
NH <sub>4</sub> <sup>+</sup> -N	1.0
Phosphate (PO <sub>4</sub> <sup>-3</sup> )	4
SiO <sub>2</sub>	50
Aluminum	0.1
Iron	0.5
Manganese	0.5
Calcium	50
Magnesium	0.5
HCO <sub>3</sub> <sup>-</sup>	24
Sulfate (SO <sub>4</sub> <sup>-2</sup> )	200

**Figure 31 - Water Quality Requirements for Cooling Towers (EPA, 1992)**

### *5.5.2. Potential Water Sources*

The principal sources of water for cooling towers are secondary municipal effluent and used make-up water from once-through cooling systems. In most cases, secondary effluent is a more viable source, due to the large quantities available and minimal treatment requirements. Further, blowdown water from the cooling towers can often be used in other applications such as metal cleaning, washracks, and metal plating, as previously indicated.

### *5.5.3. Treatment Requirements*

While secondary effluent is often nearly "clean" enough to be used in cooling towers, some degree of treatment must usually be done to prevent operating problems. Generally speaking, there are four types of problems that can be encountered when using secondary effluent. Cooling tower operators will not normally experience these problems when water that is treated to meet standards listed in Section 5.5.1.

#### **5.5.3.1. Scaling**

Scaling is the buildup of hard deposits on pipe (or other metallic) surfaces, which reduce the efficiency of the cooling towers. Scales are typically caused by calcium and magnesium deposits from constituents in the process water. There are a number of ways to control scale formation. Reducing pH by adding acids such as sulfuric acid, hydrochloric acid, CO<sub>2</sub> gas, and SO<sub>2</sub> gas limits the solubility of scale-forming compounds. Lime addition can be performed to remove hardness and alum addition can be done to remove phosphates. These processes must be followed by sedimentation to remove settled solids. Finally, ion exchange can be used to remove metal cations (i.e. Ca<sup>+2</sup>, Mn<sup>+2</sup>, Mg<sup>+2</sup>, etc.) in the water (Metcalf and Eddy, 2003; EPA, 1992).

### **5.5.3.2. Corrosion**

Corrosive conditions on metallic surfaces are more likely when using secondary effluent as compared to potable water, due to the significantly higher TDS concentrations present. TDS increases electrical conductivity in the water, which in turn promotes corrosion. Manganese, iron, aluminum, and dissolved oxygen all contribute to the corrosive potential, since they are strong oxidants. Further, low pH waters ( $\text{pH} < 6.5$ ) will also foster corrosion. Lime or soda ash addition can be performed to raise pH. Corrosion inhibitors, such as polyphosphates and polysilicates can also be used. Ion exchange and reverse osmosis are also viable options, but are often cost prohibitive for this type of application (Metcalf and Eddy, 2003; EPA, 1992).

### **5.5.3.3. Biological Growth**

The moist environment of the cooling tower promotes microbial growth. This is a problem on two fronts. First, process efficiency and water flow may be reduced in the tower, along with possible generation of corrosive by-products. Second, microorganisms and pathogens emitted in evaporated water and drift can be a health hazard for personnel working near the cooling towers, or others who may be exposed. The primary constituents of concern include organic matter (BOD), nitrogen, and phosphorous. Two approaches may be used to inhibit biological growth. Chlorine or other disinfectants can be added to the secondary effluent to control biological growth and remove pathogens. Additionally, advanced treatment of the secondary effluent, such as nitrification, denitrification, biological phosphorous removal, coagulation and flocculation, and filtration may be employed to further reduce nutrient availability in the water. Most of these processes (except filtration) will require sedimentation to remove settled solids (Metcalf and Eddy, 2003; EPA, 1992).

#### **5.5.3.4. Fouling**

Fouling is defined as the attachment and growth of deposited materials in cooling towers.

Deposits may contain biological matter, suspended solids, scale, or corrosion by-products. As with other operational problems, performance efficiency is reduced as a result of fouling.

Fouling is normally controlled by the use of chemical dispersants to prevent particulate formation or with pretreatment using coagulants and/or filtration. Pretreatment can include a separate coagulation/flocculation process followed by sedimentation or filtration. Phosphorous removal using alum or ferric chloride has been shown to be very effective in reducing fouling (Metcalf and Eddy, 2003; EPA, 1992).

## 6. IRRIGATION

Irrigation can create substantial water demands on Navy facilities. The majority of bases have large grass-covered areas, including residential and office lawns, recreational fields, airfields, grassy medians, shoulders along roads, and parade fields, to name a few. Further, many bases have golf courses, which require constant watering to provide high-quality playing surfaces. In fact, the bulk of irrigation on Navy bases is done on golf courses. Often, golf courses will use manmade lakes that collect rainwater and natural runoff, but these sources are often not sufficient to provide for peak demand, especially during summer months or dry periods. Instead, they often have to rely on underground wells or potable sources to meet irrigation requirements.

This section considers the potential water reuse applications for irrigation on Navy installations. The primary focus is on golf course irrigation using secondary municipal effluent, since it requires the most water and is the most widely implemented practice to date. Irrigation in non-residential and recreational areas is also considered. Finally, residential lawn irrigation using greywater systems is addressed. Agricultural irrigation is not considered in this report for two of reasons. Although the Navy leases some of its unused land for agricultural use, this is neither a mission-essential function nor a morale/ recreation issue. Second, unless an agricultural lease is already in place, implementing a water reuse strategy is not a likely catalyst to get one started. However, bases with existing agricultural leases may consider using treated municipal effluent as an irrigation source. Design considerations are similar to those for golf courses, with additional provisions for the type(s) of crops grown.

## 6.1. GOLF COURSE IRRIGATION

Golf course irrigation using secondary municipal effluent has been practiced for many years in arid regions of the United States, such as California, Nevada, and Arizona with great success. In fact, it has become standard practice in many of these areas. However, more water-rich areas have begun to add these systems in the interest of water conservation, to stem rising water costs, and reduce potable water demand. This is especially true in coastal areas like Florida, where salt-water intrusion has become a major concern for coastal aquifers. Secondary effluent is plentiful, cheap, and provides an excellent alternative to using groundwater or treated potable supplies.

### *6.1.1. Water Quality*

This section addresses EPA recommended water quality standards and common quality problems associated with irrigation water reuse.

#### **6.1.1.1. EPA Recommended Standards**

The EPA has established standards for unrestricted urban reuse, which includes irrigation. Unrestricted urban reuse is defined as "irrigation of areas where public access is not restricted, such as parks, playgrounds, school yards, and residences; toilet flushing, air conditioning, fire protection, construction, ornamental fountains, and aesthetic impoundments" (EPA, 1992). Technically, golf courses fall under a slightly more lenient classification of restricted urban reuse, but since the water may be used for other purposes (i.e. lawn irrigation, recreational fields), where there is widespread public access, it is prudent to treat to the stricter standard. The recommended treatment standards for unrestricted urban reuse are shown on the following page (EPA, 1992):

<u>Constituent</u>	<u>Limit</u>
Chlorine Residual	1 mg/L
PH	6 - 9
BOD	10 mg/L
Coliforms	14/100 mL
Turbidity	2 NTU
TSS	5 mg/L
TDS	500 - 2,000 mg/L
Pathogens	Below Detectable Limits

**Figure 32 - Recommended Water Quality Requirements for Unrestricted Urban Reuse (EPA, 1992)**

Further, the EPA has established recommended limits for inorganic constituents (primarily trace heavy metals) in reclaimed irrigation water (EPA, 1992):

<u>Constituent</u>	<u>Long Term Use (mg/L)</u>	<u>Short Term Use (mg/L)</u>
Aluminum	5.0	20
Arsenic	0.10	2.0
Beryllium	0.10	0.5
Boron	0.75	2.0
Cadmium	0.01	0.05
Chromium	0.1	1.0
Cobalt	0.05	5.0
Copper	0.2	5.0
Fluoride	1.0	15.0
Iron	5.0	20.0
Lead	5.0	10.0
Lithium	2.5	2.5
Manganese	0.2	10.0
Molybdenum	0.01	0.05
Nickel	0.2	2.0
Selenium	0.02	0.02
Vanadium	0.1	1.0
Zinc	2.0	10.0

**Figure 33 - Recommended Limits for Inorganic Constituents in Reclaimed Irrigation Water (EPA, 1992)**

### 6.1.1.2. Potential Quality Problems

Secondary municipal effluent will normally have more impurities than groundwater or surface water supplies, including metal ions and other trace elements, chlorine residuals, and nutrients. Some of these constituents may cause problems in the turf grass and/or underlying soils. The key indicators for judging irrigation water quality are salinity, sodium levels, toxic element concentrations, bicarbonate, pH, and nutrient content. Each factor is addressed below.

#### 6.1.1.2.1. Salinity

When soluble salts build up in the root zone, due to high concentrations in applied irrigation water, salinity problems may result. Salinity reduces water uptake by lowering osmotic potential in the soil. As a result, plants use most of their energy to adjust salt concentration to get enough water instead of on plant growth. This problem is most severe in hot and dry climates. Further, concentrations of ions, such as sodium, chloride, and boron can build up in the soil over time and cause human health hazards or become toxic to plant life. Salinity problems generally occur in irrigation waters with electrical conductivities ( $EC_w$ ) greater than 0.75 dS/m. Severe problems occur when water with  $EC_w$  of 3.0 dS/m or higher is used. Golf course grasses must be evaluated to determine if they can tolerate salinity in reclaimed wastewater, or the water must be treated to remove salts. Below 3.0 dS/m most turf grasses are not significantly affected. Between 3 to 10 dS/m, most turf grass growth is restricted, and above 10 dS/m, only the most tolerant grasses will grow. The following table indicates the relative salinity tolerances of common turf grasses. Tolerance ratings are based on soil salt levels and defined as follows (USGA, 1994; EPA, 1992):

- Sensitive (S): < 3 dS/m
- Moderately Sensitive (MS): 3 – 6 dS/m
- Moderately Tolerant (MT): 6 – 10 dS/m
- Tolerant (T): 10 dS/m

**Name****Rating****COOL SEASON TURFGRASS**

Alkalagrass ( <i>Puccinellia</i> spp.)	T
Annual bluegrass ( <i>Poa annua</i> L.)	S
Annual ryegrass ( <i>Lolium multiflorum</i> Lam.)	MS
Chewings fescue ( <i>Festuca rura</i> L. spp. <i>Commutata</i> Gaud.)	MS
Colonial bentgrass ( <i>Agrostis tenuis</i> Sibth.)	S
Creeping bentgrass ( <i>Agrostis palustris</i> Huds.)	MS
Creeping bentgrass cv. Seaside	MT
Creeping red fescue ( <i>Festuca rubra</i> L. spp. <i>rubra</i> )	MS
Fairway wheatgrass ( <i>Agropyron cristatum</i> (L.) Gaertn.)	MT
Hard Fescue ( <i>Festuca longifolia</i> Thuill.)	MS
Kentucky bluegrass ( <i>Poa pratensis</i> L.)	S
Perennial ryegrass ( <i>Lolium perenne</i> L.)	MT
Rough bluegrass ( <i>Poa trivialis</i> L.)	S
Slender creeping red fescue cv. Dawson ( <i>Festuca rubra</i> L. spp. <i>trichophylla</i> )	MT
Tall Fescue ( <i>Festuca arundinacea</i> Schreb.)	MT
Western wheatgrass ( <i>Agropyron smithii</i> Rydb.)	MT

**WARM SEASON TURFGRASS**

Bahiagrass ( <i>Paspalum notatum</i> Fluegge)	MS
Bermuda grass ( <i>Cynodon</i> spp.)	T
Blue grama ( <i>Bouteloua gracilis</i> (H.B.K.) Lag. ex. steud.)	MT
Buffalograss ( <i>Buchloe dactyloides</i> (Nutt.) Engelm.)	MT
Centipedegrass ( <i>Eremochloa ophiuroides</i> (Munro) Hackel)	S
Seashore paspalum ( <i>Paspalum vaginatum</i> Swartz.)	T
St. Augustine grass ( <i>Stenotaphrum secundatum</i> (Walter) Kuntze)	T
Zoysiagrass ( <i>Zoysia</i> spp.)	MT

**Figure 34 - Salinity Tolerance Levels of Various Turf Grasses (USGA, 1994)**

#### 6.1.1.2.2. Sodium

High levels of sodium in reclaimed irrigation water can lead to reduced permeability and aeration in underlying soil. This is because sodium salts affect the cation composition in the first few inches of soil. Typically, this phenomenon occurs when there is high sodium content and/or low calcium or magnesium content in the irrigation water. Calcium and magnesium ions tend to stabilize the soil structure, where sodium has a destabilizing effect. The effect of irrigation water on permeability of a soil is expressed using the Sodium Adsorption Ratio (SAR), which is defined below:

$$\text{SAR} = \frac{\text{Na}}{[(\text{Ca} + \text{Mg})/2]^{1/2}}$$

Na = sodium ion concentration (meq/L)

Ca = calcium ion concentration (meq/L)

Mg = magnesium ion concentration (meq/L)

Waters with SAR greater than 9 can cause significant permeability problems in clay soils over time. Sandy soils can tolerate a SAR of this magnitude with less impact. Golf courses that have been designed with sandy soils that drain well are less susceptible to problems from high SAR irrigation waters (USGA, 1994; EPA, 1992).

#### 6.1.1.2.3. Toxic Elements

Trace toxic elements in reclaimed wastewater may pose potential problems if allowed to accumulate to toxic levels in the soil or turf grasses. Boron, chloride, and sodium cause the most problems with plant toxicity. Chloride concentrations greater than 355 mg/L or sodium levels of 70 mg/L or more can cause damage to ornamental plants. Boron is most likely to cause toxicity problems in turf grass. It usually comes from soap and detergent residues still in the secondary effluent. It can cause problems at concentrations higher than 2.0 mg/L. Some heavy metals like zinc and copper are actually good for turf grass, but others such as nickel, molybdenum, and cadmium can cause adverse effects in plants, animals, and humans. To minimize problems from

trace toxic elements, water should be treated to meet the standards listed in Section 6.1.1.1 (USGA, 1994; EPA, 1992).

#### 6.1.1.2.4. Bicarbonate

Bicarbonate ( $\text{HCO}_3^-$ ) may also affect soil permeability, similar to sodium. It will combine with calcium or magnesium ions to form calcium or magnesium carbonate precipitates ( $\text{CaCO}_3$  (s) or  $\text{MgCO}_3$  (s)). As a result, the SAR will increase leading to permeability problems. Further, high bicarbonate concentrations will tend to increase soil pH. Typically, bicarbonate concentrations less than 1.5 meq/L are desired (USGA, 1994).

#### 6.1.1.2.5. pH

The desired pH range for most soils is 5.5 – 7.0. Irrigation water pH should be around 6.5 – 8.4. Waters out of this range need to be evaluated for other constituents, such as bicarbonate, which will cause permeability problems as previously described. In addition, soils in the western U.S. often have naturally high pH and may cause iron or other elemental deficiencies in plants grown in them (USGA, 1994).

#### 6.1.1.2.6. Nutrients

Nitrogen, phosphorous, and potassium are often present in secondary effluents. These nutrients have a beneficial impact on turf grass growth. However, much of the nitrogen and phosphorous may be removed during secondary and advanced treatment at the wastewater treatment plant. As such, fertilizers and supplements may still be required to ensure proper grass growth. Further, while nitrogen is beneficial to plant growth, surplus amounts can seep into groundwater, potentially causing NPDES permit limits to be exceeded (USGA, 1994; EPA, 1992).

### *6.1.2. Water Treatment Requirements*

In order to meet EPA recommended standards for unrestricted urban reuse (see Section 6.1.1.1.), secondary treatment, disinfection, and filtration are normally required. Virtually all municipal effluents have undergone secondary treatment and disinfection to meet Federal and state discharge requirements. However, the level of advanced treatment varies by locality. The primary concern in using municipal wastewater effluents for irrigation purposes is the minimization of health risks due to disease vectors in the water. Adequate disinfection is required to ensure pathogens and viruses have been killed. It is also recommended that a chlorine residual of 0.5 to 1 mg/L is maintained to prevent odors and inhibit bacterial regrowth. Advanced treatment may include coagulation/flocculation followed by sedimentation or coagulant addition before filtration to remove many of the toxic elements listed in Section 6.1.1.1 (EPA, 1992). Ion exchange may also be a viable option, but can be considerably more expensive. Strategies for dealing with the common water quality problems described in the previous section are described below:

#### **6.1.2.1. Salinity**

There are a number of methods, both physical and chemical, to deal with irrigation waters that have high SAR ratios. Poor quality water can be blended with less salty water using a reservoir or storage pond. This can involve mixing with potable supplies and/or natural runoff from precipitation and other sources. Another option is to apply extra water than required to leach excess salt below the root zone. When designing a new golf course, it is advisable to plant grasses with a high salinity tolerance. If hard soils or clayey soils are present, replace them with more permeable sandy soils. If poor drainage conditions exist or if the water table is shallow, artificial drainage can be installed (USGA, 1994). The water may also be treated to remove

some or most of the sodium ions using filtration, coagulant addition (and subsequent flocculation/sedimentation), and ion exchange.

#### **6.1.2.2. Sodium**

Sodium-related permeability problems can be mitigated using many of the same techniques for salinity. In addition, gypsum, sulfur, or sulfur dioxide may be applied to increase soluble calcium ion concentrations in the soil (USGA, 1994).

#### **6.1.2.3. Toxic Elements**

In order to minimize accumulation of toxic elements in the soil, a number of techniques may be used. Similar to dealing with salinity and sodium problems, water can be blended with potable supplies and/or natural runoff from precipitation in a reservoir or storage pond. Also, excess or more frequent irrigation can be employed to prevent constituent buildup and encourage leaching out of the root zone (USGA, 1994).

#### **6.1.2.4. Bicarbonate**

Bicarbonate permeability problems can be mitigated in the same manner as salinity. If coagulant addition is performed, alum or ferric chloride should be used, since they will remove bicarbonate alkalinity through precipitation. Lime addition will generate significantly more sludge than alum or ferric chloride, and is therefore not recommended for this purpose (Hao, 2003). Limiting pH increases resulting from high bicarbonate concentrations can be done by adding acids to the irrigation water (i.e. sulfuric acid, phosphoric acid) or by using acidifying fertilizers like ammonium sulfate (USGA, 1994).

#### **6.1.2.5. pH**

Soil pH outside the recommended range should be adjusted up or down to promote optimal growth conditions. If a soil is too acidic, lime can be added to increase pH. Conversely,

acidifying fertilizers can be added to decrease pH in alkaline soils. It is important to consider soil pH, texture, percent saturation, characteristics of the additive material, and turf grass species before implementing a pH adjustment scheme (USGA, 1994).

#### **6.1.2.6. Nutrients**

Nitrogen is often the constituent of concern, since permitted discharges are typically very strict. Nitrification and/or denitrification processes may need to be incorporated into biological treatment at the wastewater treatment plant or separate units, such as denitrifying filters may need to be installed. Similarly, phosphorous removal during biological treatment or by coagulation, flocculation, and sedimentation can be performed. Another option is land treatment of the secondary effluent (i.e. slow-rate filtration). In some cases, the grass and natural soils may remove nutrients to acceptable levels. The depth to groundwater and/or potable aquifers will partially determine the effectiveness and acceptability of land treatment. Consequently, the nutrient requirements of turf grass as well as removal potential by the soils must be studied before a treatment scheme is implemented.

#### *6.1.3. System Design Requirements*

This section considers the various design requirements for new systems and/or modifications that must be made to existing irrigation systems to allow for non-potable water reuse.

##### **6.1.3.1. Water Distribution System**

Design requirements are similar to those for a standard potable distribution system. Materials of equal quality and construction are recommended. Distribution mains should be sized to accommodate peak hourly demands. Typically, watering will occur at night when there is a minimum chance of contact with golfers. The system must be sized to meet demand during

this window. If storage lakes are used, filtration should be provided for water pumped from the lake. This will prevent clogging of the pump. The inlet from the lake should have a primary screen (10-30 mesh) to prevent large objects from entering the pump. Self-cleaning screens prevent the need for manual cleaning. Sprinklers that have a precipitation rate less than or equal to the soil infiltration rate should be chosen to prevent runoff. Impact heads are desirable since they are less apt to clog. Flush valves should be installed in low spots and dead-ends (USGA, 1994; EPA, 1992).

#### **6.1.3.2. Pressure and Flow Requirements**

System pressure for irrigation systems can be as low as 10 psi (70 kPa) if booster pumps are provided at the point of delivery. If not, maximum system pressure can be as high as 100 to 150 psi (700 to 1000 kPa). Flow controllers should be installed, since they will shutdown the water line if a pipe breaks. Also, irrigation schedules should be developed to avoid ponding and runoff. Drains should be installed on greens, tees, fairways, and roughs. Preventing compaction is also important for good drainage. One method is to install cart paths when feasible. Drainage should normally be retained on site, either by channeling back to the storage facilities or into a large gravel sump. Discharge into sewer systems normally requires an NPDES permit (USGA, 1994; EPA, 1992).

#### **6.1.3.3. Identification of Piping and Appurtenances**

All piping and appurtenances in a non-potable distribution system should be clearly and consistently identified. Color coding and marking are two common identification techniques. An example of a marking is "CAUTION: NON-POTABLE WATER – DO NOT DRINK". Markings may be stenciled or taped to the pipes. If pipes are colored, they should clearly stand

out from potable lines (i.e. by painting them brown or orange). Some examples of advisory signs are shown below:



**Figure 35 - Typical Water Reclamation Advisory Signs (FDEP, 2003)**

Fittings used for non-potable and potable lines should be incompatible to prevent cross-connections between the two systems. Hose bibs that discharge reclaimed water should be secured to prevent public access and have signs posted that read similar to markings on distribution pipes. Valve boxes and electrical components should be color coded with warnings stamped on them. Stainless steel cabinets mounted with stainless steel lag bolts should be used to prevent corrosion. Their covers should not be interchangeable with those used for potable sources. If a pumping facility is used, it must be clearly labeled as a non-potable source. Specific identification requirements can be found in the American Water Works Association's *Guidelines for Distribution of Nonpotable Water* (USGA, 1994; EPA, 1992).

#### **6.1.3.4. Separation of Potable and Non-Potable Piping**

If potable and non-potable water lines are parallel to each other, a 10 ft horizontal separation and 1 ft vertical separation must be maintained. Non-potable lines should be buried

deeper than potable lines to prevent infiltration. In most cases, non-potable lines should be buried at least 3 ft below grade (EPA, 1992).

#### **6.1.3.5. Site Characteristics**

In order to properly evaluate a site for irrigation using reclaimed water, a number of factors must be considered. They include topography, soil characteristics, groundwater, and climate.

##### **6.1.3.5.1. Topography**

Topographical considerations include slope, relief, and susceptibility to flooding. A site's potential to add stormwater runoff, create drainage problems, promote groundwater seepage, and relief drainage must all be evaluated. Steep slopes are not desirable since they increase the amount of runoff and erosion. They also lead to unstable soil conditions, and can be expensive to irrigate due excessive to runoff. Typically, no more than 15 to 20% slope is recommended at the site. Relief is defined as elevation changes at a site, such as hills and valleys. Too much relief increases pumping costs, since additional power must be supplied to overcome elevation increases. Finally, the potential for flooding must also be considered. Flood maps created by the National Flood Insurance Program and Federal Emergency Management Association should be consulted to determine if the area is in a floodplain. Floodplains have highly variable drainage conditions and are more susceptible to equipment damage and contamination in heavy precipitation events (Pettygrove and Asano, 1985).

##### **6.1.3.5.2. Soils**

The types of soils present (or planned) at a site need to be identified as well as their physical, chemical, and drainage characteristics. Soil surveys are normally available from Soil Conservation Service (SCS) or the U.S. Geological Service (USGS). Infiltration rate and

hydraulic conductivity are key hydraulic factors that need to be determined for a soil. Minimum infiltration rate must be known to design sprinkler systems. For multiple or mixed strata, the lowest hydraulic conductivity is the usually determining factor. Soil chemistry, such as pH and electrical conductivity, must also be considered to determine how reuse water application will impact soil vegetation, permeability, and durability of the soil matrix (Pettygrove and Asano, 1985).

#### 6.1.3.5.3. Groundwater

It is extremely important to evaluate the sources of groundwater present at the site. Depth to groundwater and groundwater quality are the most significant parameters that must be evaluated. Groundwater depths greater than 3 or 4 ft are usually preferred, especially when land treatment is employed. Some states require greater depths to prevent groundwater contamination, depending on the quality of the aquifer. Groundwater aquifers are classified according to their quality. High-quality (i.e. potable) aquifers will have more stringent regulations than lower quality aquifers (Pettygrove and Asano, 1985).

#### 6.1.3.5.4. Climate

In order to determine the required irrigation water quantities and application cycles, climatic factors must be studied. Historical monthly and annual precipitation and temperature, length of the growing season, and prevailing winds are some of the criteria that should be evaluated when designing a system and determining its feasibility.

#### 6.1.3.6. Backflow Prevention

Some form of backflow prevention is required to protect potable water supplies. If a potable source exists near the pumping facility, an air gap should be created to prevent backflow into the potable system. If the possibility of cross-connection exists, such as in areas where both

potable and non-potable sources are present, backflow prevention devices must be placed on the potable water line to prevent potential intermixing with backflow from the non-potable source. Backflow prevention is not normally required on the non-potable system, except when on-site chemical addition is performed for irrigation purposes (EPA, 1992).

## 6.2. OTHER NON-AGRICULTURAL IRRIGATION

Other non-agricultural irrigation applications include watering lawns around office and industrial facilities, recreational fields, airfields, grassy medians, shoulders along roads, and parade fields, as previously indicated. EPA guidelines for unrestricted urban reuse hold for these applications. Similar design considerations and water quality issues to those faced when planning golf course irrigation reuse can be assumed. In most cases, these areas are not irrigated with either the frequency or quantity of water used for golf courses. Many bases, especially those in wetter climates (i.e. U.S. east coast) do not irrigate these areas at all. However, they provide additional options for using reclaimed water when a water reuse scheme is being planned. Ultimately, increasing water reuse consumption on a base will reduce the amount of secondary effluent (and contaminants) discharged to receiving waters.

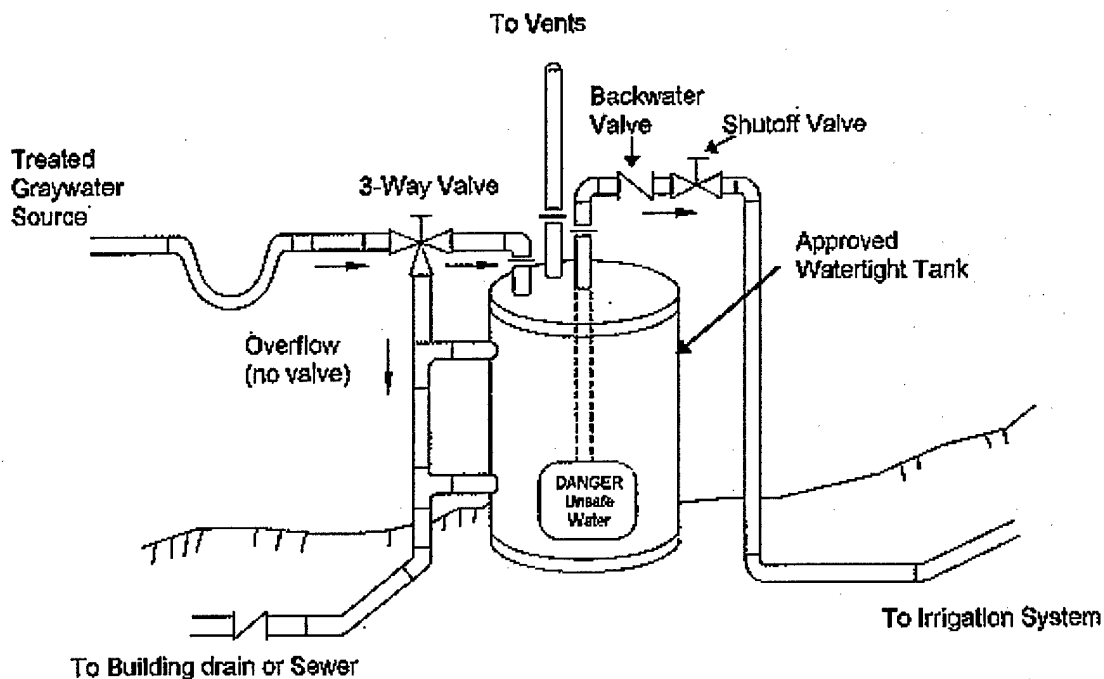
## 6.3. RESIDENTIAL LAWN IRRIGATION

The most feasible water reuse application for residential lawn irrigation involves the use of greywater collected from bathroom sinks, washing machines, and/or showers in the home. The water can be stored, treated, and used in place of potable supplies. There are a number of design and health issues that must be considered before a greywater irrigation system is installed.

### 6.3.1. System Design

#### 6.3.1.1. Greywater Collection, Storage, and Distribution

A greywater collection system requires separate piping to collect effluent from greywater sources and store it for later use. Depending on the configuration of the home, existing sewer and water lines will need to be modified to incorporate a dual wastewater piping system (i.e. separate greywater and blackwater piping). Piping will typically be composed of PVC, while the storage tank will be made of fiberglass or industrial-strength plastic. Local building codes may require labeling of piping or use of different materials to indicate non-potable use. Hose-bibs (if any exist) must be labeled to indicate that they dispense non-potable water. Check valves will also be required in the distribution system (NAPHCC, 1992). A typical greywater irrigation system is shown below:



**Figure 36 - Typical Greywater Irrigation System (NFESC, 1993)**

### 6.3.1.2. Irrigation Methods

Many states have approved greywater irrigation systems for domestic use, but have limited the applications to sub-surface irrigation only. This is because aboveground irrigation with greywater, especially if it is untreated (as is often the case) can create unnecessary health risks. Also, greywater systems typically operate at very low pressure (usually by gravity flow) and may not be adequate to service hose bibs, sprinkler heads, or arcing sprinklers. The most common types of irrigation systems are mini-leach fields and drip irrigation (NAPHCC, 1992; Milne, 1979).

A mini-leach field is constructed by digging a trench along the outer perimeter of the lawn (or vegetated area) and filling it with gravel about 4 inches from surface. An open tube or perforated pipe opening is located at the top of the gravel surface, which provides greywater input from the storage tank. The gravel is lined with building paper or weed-stop to prevent vegetation in the gravel. The trench is then filled to the ground surface with soil. Mini-leach fields are relatively cheap and easy to install and can be very effective. However, they are best suited for irrigation of trees and other deep-rooted plants.

A drip irrigation system uses a pipe or hose to carry water from the storage tank to the irrigation area. The pipe is sloped downhill to provide gravity flow. Smaller perforated tubes (called drip lines) are connected to the main tube at right angles, which distribute the water evenly in the lawn. Drip lines are normally buried 4 to 12 inches below ground surface. One advantage of a drip irrigation system is high efficiency and little evaporation loss. Also, these systems work well in areas where salinity is high. Since flow is constantly downward, salts are leached past the root zone so they don't build up in the grass. Also, they can be used on uneven terrain. Two major disadvantages exist. First, drip irrigation systems can be expensive to install.

Second, they can get clogged if suspended solids are not first removed by filtration (NAPHCC, 1992; Milne, 1979).

### *6.3.2. Treatment Requirements*

Generally speaking, many of the same problems for golf course irrigation water quality apply to residential greywater systems. Odor control, nutrient limitation, and pathogen removal top the list of concerns. The most common treatment techniques are filtration and disinfection. Filtration is performed to remove suspended solids and foam from soap and detergent use. Filters can be as simple as nylon or cloth bag attached to the storage tank inlet. More commonly, sand or mixed media filters will be used. Disinfection can be accomplished through chlorination, ozonation, or UV radiation. Due to the relatively low cost and scale of most potential greywater systems, chlorine is the most popular disinfectant. Chlorine tablets are typically used for disinfection in residential greywater systems (NAPHCC, 1992). More advanced treatment options can be used, such as biological treatment, coagulation/ flocculation/sedimentation, and membrane processes, but they are often cost prohibitive or impractical given the quantities of water used and land use constraints.

## 7. TOILET AND URINAL FLUSHING

Restrooms account for 45% percent of overall water use in both residential and office facilities and are the single largest water consumers. Toilet and urinal flushing consumes far more water than other restroom activities. The average person flushes a toilet (or urinal) 7 times per day. Toilets use between 1.6 to 6 gallons per flush, while urinals use between 0.5 and 2 gallons per flush. Consequently, the average person uses between 3.5 and 42 gallons of water per day on toilet and/or urinal flushing alone (Magro, 1995). Furthermore, since toilet and urinal water does nothing more than transport the contents to a sewer or septic system, it stands to reason that a lesser quality of water can be used for this purpose with few or no ill effects.

The most viable water reuse application for toilet and urinal flushing involves the use of greywater collected from other appliances in the office or residence, such as bathroom sinks, showers, and washing machines. Between 53 and 81% of residential water use is considered greywater. Greywater quality is significantly better than blackwater, especially with respect to nitrogen and BOD loading, which come primarily from bodily wastes and kitchen sink effluent. When washing machines are used, phosphorous loading can be significant, but with low phosphate detergents recently available and stricter phosphorous discharge permits, this may not necessarily be an issue. Pathogens, such as coliforms, staphylococcus, and streptococci may be present in greywater, but in concentrations that are many orders of magnitude less than would be observed in blackwater (NAPHCC, 1992).

## 7.1. SYSTEM DESIGN

A dual piping system will be required in facilities where greywater is used. Effluent from bathroom sinks, washing machines, and/or showers will have to be collected and sent to a storage tank for future use. This may pose a significant challenge for existing buildings, since many utilities are buried and will have to be uncovered and/or replaced in order to install a dual piping system. Piping will typically be composed of PVC, while the storage tank will be made of fiberglass or industrial-strength plastic. Backflow prevention devices (check valves) will be required to ensure collected greywater does not return to its source or other parts of the distribution system and create contamination problems. Depending on the relative elevation of greywater storage facilities to the toilets and urinals (i.e. in a multi-storage building), pumps will likely be required to transport greywater to or from the storage tank and/or provide system pressure. Controls may be either automatic or manual, depending on the complexity desired and amount of money available (NAPHCC, 1992).

## 7.2. TREATMENT

Treatment options are similar to those used for residential greywater irrigation systems. More advanced treatment options can be used, such as biological treatment, coagulation/flocculation/sedimentation, and membrane processes, but they are often cost prohibitive or impractical given the quantities of water used and land use constraints.

## 8. WATER STORAGE FACILITIES

Water storage is often required for reuse applications, due to seasonal and hourly variations in demand. For example, most golf course watering is done at night or in the early morning hours when flow into the wastewater treatment plant is at a minimum. During the summer, significantly higher irrigation and industrial use requirements (i.e. water for cooling towers) exist. One of the primary purposes of water reuse is to steer towards the goal of “zero discharge” as outlined in the Clean Water Act. In order to do this, storage facilities are often constructed to collect reuse water during times of low demand and ensure there is adequate supply during high demand.

Water storage facilities can be either open or closed. A number of operating methods can be used for both open and closed systems. They include: (1) off-line and on-line storage, similar to equalization methods discussed in Section 4.1.4, (2) long term storage of winter flows for summer discharges, and (3) long-term storage of summer flows for winter discharge. The most common method is off-line storage. This method minimizes pumping costs and ensures that off-hour (i.e. nighttime) peak demands will be met. Another popular application is long-term storage of winter flows for summer discharge, due to the typically lower requirements during winter months (Metcalf and Eddy, 2003). Open and closed systems are individually addressed below.

## 8.1. OPEN RESERVOIRS

Open reservoirs are the most common form of water storage on military bases. They usually take the form of lakes, ponds, and stormwater detention facilities. Open reservoirs can be used for recreation, sources of irrigation water, and aesthetic beauty. For example, many golf course water hazards are actually storage facilities for irrigation water.

Common problems associated with open reservoirs include odors, loss of chlorine residual, low dissolved oxygen resulting in fish kills, excessive algae growth, color, and bird or rodent infestation. Each of these issues can lead to significant deterioration of water quality and make water reuse a "hard sell" for a base. Fortunately, there are many ways to improve the water quality and prevent future problems. The most common method involves aerating the reservoir. Aeration devices include fountains, air injectors, waterfalls, and cascading rock formations. Another option is to add chemicals such as alum and copper sulfate. Alum prevents phosphorous release from lake sediments and will precipitate suspended solids. Copper sulfate can be used to control algae growth. Physical methods such as filtration at the distribution system inlet and dilution with higher quality water can also be used. Cultivation of constructed wetlands is another option, but these may require more land area than a base has to spare. Finally, reservoirs can be dredged periodically to remove sediments and other undesirable matter (Metcalf and Eddy, 2003; USGA, 1994).

## 8.2. ENCLOSED STORAGE

Enclosed storage can be performed either through the use of storage tanks or in-situ containment. Storage tanks can be either gravity flow or pressurized, and can even be used to augment other non-potable supplies, such as fire protection. In-situ techniques include mounded filters, slow-sand filters, and aquifer storage and recovery. Each of these options was described in Section 4. A benefit of in-situ storage is that water is treated through natural processes, which may significantly improve its quality.

Enclosed storage systems also encounter problems that must be addressed. They include stagnation, odors, loss of chlorine residual, and bacterial regrowth. Common strategies to deal with enclosed storage problems include recirculation and aeration of the water and chlorine addition to maintain adequate residuals (Metcalf and Eddy, 2003).

## 9. RISK MANAGEMENT

Water reuse projects involve some level of risk to human health, the environment, or both.

Before a project can go forward, risks must be quantified and weighed against the benefits executing the project. This process is known as risk management. The National Research Council defines risk management as “the process of weighing policy alternatives and selecting the most appropriate regulatory action, integrating the results of risk assessment with engineering data and social, economic, and political concerns to reach a decision” (Eisenberg, 2003). The process of risk management centers on three key factors that must be considered when making a risk-based decision. They include:

- Risk Assessment
- Cost
- Public Opinion

This section describes each of these factors as they relate to water reuse risk management.

### 9.1. RISK ASSESSMENT

A risk assessment must be performed to determine the effects of biological and chemical contaminants in reclaimed water on human health and the environment. Risk assessment often provides the primary decision factor(s) in a risk management decision. Namely, if a proposed project poses an unacceptable risk to the population or the environment, its cost or how the public feels about it won't matter.

Before a discussion of risk assessment can begin, an understanding of the uncertainties associated with this process must be understood. Nature and its processes are infinitely complex. Even in today's day and age, our knowledge of transport mechanisms, biological, physical, and

chemical interactions, contaminant inventories, and human response to contaminant exposure is limited. Selection of treatment techniques is often based on trial and error, past experience, or empirical methods, rather than “hard” science. As such, much of the data obtained from a risk assessment study are closer to a best guess than proven scientific fact.

Two primary types of uncertainty exist in risk assessments. They include aleatory (Type A) and epistemic (Type B) uncertainty. Aleatory uncertainty is variability of parameters used in a study. Variability may be either spatial, temporal, or both. It is random and hard to quantify. In order to reduce aleatory uncertainty, the scale of a problem can be reduced or a more complex model can be used. Simplifications (i.e. assuming constant temperature or groundwater velocity) are often a primary cause of aleatory uncertainty. Epistemic uncertainty involves the lack of knowledge of the true value or range of values for a parameter, or even the validity of the model used. The only way to reduce epistemic uncertainty is to obtain more data (Eisenberg, 2003).

A number of procedures have been developed for performing a risk assessment. This paper uses the model developed by Field and Compton involving four steps: (1) Release Assessment, (2) Transport Assessment, (3) Exposure Assessment, and (4) Consequence Assessment (Field and Compton, 1998). Each step and the associated water reuse considerations are described below:

#### *9.1.1. Release Assessment*

Release assessment involves the identification of contaminants, estimation of quantities present, probability and rate of release into the environment (Eisenberg, 2003).

#### 9.1.1.1. Contaminant Identification

Two primary types of contaminants exist in reclaimed water. They can be classified as biological and chemical contaminants. The EPA has identified three groups of biological organisms that can be present in the water. They include: bacteria, parasites, and viruses.

Bacteria most likely to cause diseases in humans include *salmonella* species, *shigella* species, *vibrio cholerae*, *leptospira* species, *yersinia enterocolitica*, *francisella tularensis*, *escherichia coli*, and *pseudomonas aeruginosa*. Bacteria are often very difficult to identify because there are so many strains and one single test has not been developed to classify all of them. Further, bacteria are often present in extremely small quantities and are hard to detect. Consequently, indicator tests such as fecal coliform counts have been developed to obtain an order of magnitude estimate of the presence of other bacterial species.

The second group, parasites can be further classified as protozoa and helminths. Protozoa that have been shown to be pathogens in humans include *entamoeba histolytica*, *giardia lamblia*, and *cryptosporidium*. Protozoans are often the culprits of waterborne disease around the world. Helminths are intestinal parasitic worms. Common species include *ascaris lumbricoides*, *trichuris trichiura*, *ancylostoma duodenale*, *necator americanus*, and *strongyloides stercoralis*.

Finally, there are over 100 different viruses that can appear in reclaimed water. Since viruses cannot replicate outside a living host, they often lose their toxicity in the water. Enteric viruses are of primary concern, since they grow in the human intestinal tract and are released in feces. The main viruses that have been shown to produce waterborne diseases are Norwalk virus, rotavirus, and Hepatitis A.

The EPA typically classifies chemical contaminants as inorganic or organic. Inorganic contaminants include trace metals and materials that enter the water from weathering or erosion. Organic contaminants include vegetation, kitchen wastes, fuels, pesticides, oils, detergents, and other similar constituents that are initially present in domestic wastewater and greywater. The primary concern associated with chemical constituents are their accumulation in vegetation, soils, surface water, and groundwater. This is especially relevant when irrigation reuse options are being considered (EPA, 1992; CH2M Hill, 1990).

#### **9.1.1.2. Contaminant Quantities and Probability of Release**

The presence and concentration of contaminants in an untreated wastewater or greywater source is often difficult to quantify. The health of the population served, chemical characteristics of the water, types of discharges to the wastewater treatment plant, and a number of other factors can greatly influence water quality. General biological and chemical characteristics of untreated wastewater and greywater are shown on the following page:

<u>Constituent</u>	<u>Range for Untreated Wastewater</u>	<u>Mean for Untreated Greywater</u>
<u>BIOLOGICAL</u>	(number/100 mL)	(number/100 mL)
Fecal Coliforms	10 <sup>4</sup> – 10 <sup>9</sup>	1210
Fecal streptococci	10 <sup>4</sup> – 10 <sup>6</sup>	326
<i>Shigella</i>	1 – 1000	-
<i>Salmonella</i>	400 – 8,000	-
Helminth	1 – 800	-
Enteric virus	100 – 50,000	-
<i>Giardia lamblia</i> cysts	50 – 10 <sup>4</sup>	-
<i>Entamoeba histolytica</i> cysts	0 – 10	-
<u>CHEMICAL</u>	(mg/L)	(mg/L)
Total Solids	350 – 1,200	700
TDS	250 – 850	-
TSS	100 – 350	155
Settleable Solids	5 – 20	-
BOD	110 – 400	255
TOC	80 – 290	200
COD	250 – 1,000	-
Total Nitrogen (as N)	20 – 85	17
Total Phosphorous (as P)	4 – 15	25
Chlorides	30 – 100	-
Alkalinity (as CaCO <sub>3</sub> )	50 – 200	-
Grease	50 – 150	50 – 150

NOTE: “-“ indicates limited or no data available.

**Figure 37 - Characteristics of Untreated Greywater and Domestic Wastewater (EPA, 1992; NAPHCC, 1992)**

The values in the preceding table are not necessarily representative quantities and there is a great deal of uncertainty associated with them. Instead, they are intended to provide order of magnitude estimates of the composition of waters used in reuse applications. Detailed laboratory analysis of site-specific water sources is required for individual projects.

### **9.1.1.3. Rate of Release**

Rate of release for a contaminant is typically measured in units of mass per time (i.e. lb/day). Flow rate into a wastewater treatment plant (or greywater storage unit) is the primary variable in determining contaminant release rate. Depending on the contaminant of concern, Federal and state regulations require treatment based on peak or average flows. For example, certain processes are based on peak hourly flows, while others are computed using annual average flows. Further, some NPDES permits (such as for Nitrogen) are based on total yearly or monthly release into the environment, rather than concentrations. Determination of the release rate is the first step in quantifying the amount of contaminants in the environment and selecting the appropriate treatment processes needed to reduce them to within regulatory standards.

### *9.1.2. Transport Assessment*

Transport assessment involves identifying all possible media through which contaminants travel and their biological, chemical, and physical interactions with those media and the environment. The purpose of a transport assessment is to determine contaminant concentrations in the air, food, water, or other media of concern at specific locations and times. Typically, this is done using mathematical or computer models that have been developed to simulate natural or manmade systems (Eisenberg, 2003; Fjeld and Compton, 1998).

When planning a water reuse project using secondary effluent, water quality data can be obtained from the local municipality. Greywater must be evaluated on a case-by case basis to obtain quality data. Using the recommended water quality guidelines described in sections 5 through 7 for the various reuse applications, the quality of the proposed water source must be evaluated to determine if it meets these standards. For constituents that do not meet standards, additional treatment will be required, as previously discussed. Historical data for treatment

efficiency, pilot tests, manual calculations, and computer simulations can all be used to estimate the destruction of contaminants in a particular treatment scheme. For land treatment, interactions with vegetation, soil, and groundwater must all be considered.

### *9.1.3. Exposure Assessment*

Exposure assessment considers the various routes, rates, and timeframes within which humans come in contact with contaminants. The purpose of an exposure assessment is to determine the dose rate or total dose of a particular contaminant or set of contaminants. Dose rate is typically expressed as milligrams of contaminant per kilogram of body mass per day (mg/kg-day). Total (or integrated) dose is expressed as milligrams of contaminant per kilogram of body mass (mg/kg).

There are three primary routes in which contaminants may enter the body. They include: (1) inhalation, (2) ingestion, and (3) skin absorption. Inhalation involves breathing contaminants through the nose or mouth. For example, breathing mists from cooling towers or golf course sprinklers when standing in close proximity to one of these sources is an inhalation route. Inhalation rate (i.e. breathing rate) varies by individual and is a function of age, weight, sex, activity level, and physical fitness, among others. EPA recommends average breathing rates of  $0.8 \text{ m}^3/\text{hr}$  for adults and  $0.4 \text{ m}^3/\text{hr}$  for children at rest. Ingestion entails consumption of contaminated materials in water, food, or soil. Adults typically consume between 0.3 to 3.8 L/day of water, whereas children drink about 0.5 to 0.8 L/day. Typically, water consumption as a source for contaminant ingestion can be neglected when performing a water reuse risk assessment, since reclaimed sources are required to be separated from potable supplies and secured against public use. The next ingestion pathway is food consumption. Contaminant ingestion from foods can be through indirect or direct contact with the contaminants. Indirect

contact involves eating animals or fish that previously consumed contaminated water or food. This process is termed "biomagnification". An example of biomagnification is eating meat from cows that grazed on contaminated grasses. Direct ingestion is consumption of contaminated foodstuffs, such as fish from a contaminated pond or vegetables grown in contaminated soil. Finally, soil ingestion must also be considered. This can result from unintended ingestion of soil from homegrown vegetables, dust from handling food or other contaminated objects (i.e. golf balls) without washing one's hands, and particulates trapped in the respiratory tract. Further, children have been known to consume between 100 to 200 mg/day of soil. The final route of exposure is skin absorption. This can involve being sprayed by a sprinkler emitting reclaimed water, or mist from a vehicle or aircraft wash station, and many other possibilities. Depending on the system used, frequency of contact with base residents, and types of contaminants present, different routes of exposure will be more significant than others (Eisenberg, 2003; Fjeld and Compton, 1998).

EPA typically uses two approaches for calculating dose rate for an individual or population exposed to a contaminant. The approach depends on the type of effect the contaminant is expected to induce. Certain contaminants produce deterministic effects, where the severity of the effect is a function of dose. This means that below a particular dose, few or no effects will be observed. As the dose increases, adverse effects such as irritation, inflammation, burning, or others will be observed. For contaminants that produce stochastic effects, the probability of the effect is a function of the dose. This means that above a given dose, there is a certain probability that an effect will occur. The most common stochastic contaminants are carcinogens. The general formula for calculating the dose rate (also called the average daily dose) is as follows:

$$\frac{dD(t)}{dt} = \frac{C \cdot IR \cdot ED}{BW \cdot AT}$$

$dD(t)/dt$  = dose rate  
 C = contaminant concentration in the medium  
 IR = intake rate  
 ED = exposure duration  
 BW = body weight (taken as 70 kg for the average human)  
 AT = averaging time

The primary difference between deterministic and stochastic contaminants lies in the treatment of the averaging time. For deterministic contaminants (non-carcinogens), the averaging time is the same as the exposure duration. For stochastic contaminants (carcinogens), the averaging time is the human lifespan (normally taken as 70 years). The latter calculation determines the so-called "lifetime average daily dose".

Total dose is defined as the integral of dose rate over the averaging time:

$$D = \int_0^{AT} [dD(t)/dt] dt = dD(t)/dt \cdot AT \quad (\text{Eisenberg, 2003; Fjeld and Compton, 1998})$$

#### 9.1.4. Consequence Assessment

The final step in a risk assessment is consequence assessment. This process involves identifying the various health effects that can result from exposure to a contaminant or contaminants and an estimate of the probability or severity of those effects. The first step in a consequence assessment is a dose-response study. For many contaminants, these have already been performed using laboratory animals. While data collected from humans are more desirable, they cannot normally be obtained in a controlled environment and lifestyle factors can significantly bias the results. Consequently, only a small number of substances have data available for humans. Numerous methods of extrapolation between animal and human response to particular contaminants are available. The most commonly accepted method is using surface area scaling as follows:

$$D_{\text{human}} = D_{\text{animal}} [BW_{\text{animal}} / BW_{\text{human}}]^{1/3}$$

$D_{\text{human}}$  = human daily dose rate (mg/kg-day)  
 $D_{\text{animal}}$  = animal daily dose rate (mg/kg-day)  
 BW = body weight (kg)

The underlying assumption is that an animal's (or human's) surface is proportional to its body weight to the two-thirds power (surface area  $\propto$  BW<sup>2/3</sup>).

Once a dose is determined that produces a particular response (i.e. 50% mortality in the test population); a more generalized relationship between dose and response is required. Since everyone will not be exposed to the same dose, the response at different dose levels needs to be projected. There are two methods for determining a generalized dose-response relationship. For stochastic contaminants, a fractional response method is used. This indicates the fraction of the exposed population that can be expected to exhibit a particular effect from a contaminant. The margin of safety approach is used for deterministic contaminants. The margin of safety is defined as the ratio of threshold dose to the actual dose received. Any dose below the threshold dose is not expected to produce a response (i.e. skin irritation, stomach cramps, etc.) in the exposed population. The EPA uses these approaches when evaluating risks associated with exposure to various carcinogenic (stochastic) and non-carcinogenic (deterministic) contaminants. For carcinogens, the most common model used is a one-hit model. This is expressed as:

$$R(D) = 1 - \exp(-\rho D)$$

$R(D)$  = fraction of the population that will develop cancer  
 $\rho$  = Cancer slope factor or potency factor (mg/kg-day)<sup>-1</sup>  
 $D$  = dose rate (mg/kg-day)

The one-hit model assumes that a single exposure to a carcinogen, however small the dose, can cause cancer. Cancer slope factors have been tabulated by the EPA for numerous known and suspected carcinogens. For non-carcinogens, a modification of the margin of safety is used called the hazard quotient. The hazard quotient is defined on the following page:

$$HQ = D/RfD$$

HQ = hazard quotient  
D = dose rate (mg/kg-day)  
RfD = reference dose (mg/kg-day)

EPA defines the reference dose as the dose that does not produce any significant effects in the most sensitive member of a population over a lifetime of exposure. EPA has recorded reference doses for many non-carcinogens.

If multiple contaminants are involved, the one-hit model is modified for carcinogens as follows:

$$R(D) = 1 - \exp(-\Sigma\rho D)$$

For non-carcinogens, the hazard index is used. The hazard index is defined as the sum of the hazard quotients for each contaminant. If the hazard index is less than 1, then the risk associated with a particular project is normally deemed acceptable. Otherwise, further analysis is required (Eisenberg, 2003; Fjeld and Compton, 1998).

## 9.2. COST

A significant factor in the decision of whether to implement a water reuse project is the net cost incurred by the Government. The standard approach used to evaluate the economic feasibility of a water conservation initiative is a Life Cycle Cost Analysis. In order to obtain Federal funding for a water conservation project, it must have an acceptable savings-to-investment ratio (i.e. benefit-to-cost ratio) and no more than a 10-year payback. Consequently, not only must a project's long-term economic yield (i.e. cost savings) exceed the start up and operating costs, but a net return must be realized within 10 years. A Life Cycle Cost Analysis and is required for all projects submitted to the Naval Facilities Engineering Command (NAVFAC) for approval and is used to calculate the payback period. The NAVFAC handbook,

P-442 contains detailed procedures for performing a Life Cycle Cost Analysis (NFESC, 1993).

The issue of cost is addressed more thoroughly in Sections 10 and 11.

### 9.3. PUBLIC OPINION

In the context of this paper, the "public" includes station and tenant personnel, base residents, and other individuals that may be affected by potential water reuse projects (i.e. golfers using a military course that is open to the public). It is extremely important to consider public opinion when planning a reuse project for two reasons. First, personnel must be made aware of the potential risks and precautions associated with water reuse. Second, if a project receives public backing, it will be more easily implemented and stands a higher chance of long-term success.

EPA has promulgated a variety of surveys regarding water reuse alternatives over the past 30 years. Results have generally indicated a positive response (80% or higher not opposed) to most non-potable water reuse applications. Surveys taken in populations where water reuse projects were being imminently considered indicated that the primary concerns, in order of importance, are as follows:

- Ability of a project to conserve water
- Environmental enhancements achieved
- Protection of public health
- Cost of treatment
- Cost of distribution

As a result of years of public opinion studies, EPA recommends that planners consider the following items when establishing a water reuse program:

- Expected degree of human contact with reclaimed water sources
- Public health protection
- Conservation and environmental benefits
- Treatment and distribution costs

It is equally important to make the public aware of the need for and reliability of water reuse applications. This includes:

- Increasing awareness of supply problems and how reclaimed water can be effectively used to meet demand
- Public understanding of the quality, treatment, and uses of reclaimed water
- Confidence in water managers and available technology to provide safe and effective treatment
- Minimal risk of accidental exposure to toxins or pathogens in the water above accepted standards

A number of tools can be used to encourage participation and foster public cooperation during the planning and execution of water reuse projects. Educational and informational materials such as newsletters, presentations, infomercials, brochures, and conferences can be used to raise the knowledge and confidence levels of affected personnel. Surveys, briefings, e-mail or phone hotlines, and public hearings can all be used to solicit comments and reactions from the base population, address concerns, and allay fears or misconceptions that individuals may have. Finally, workshops, task forces, interviews, study groups can be convened to maintain a constant dialogue between the public and planners every step of the way. The

methods and extent of public participation will vary with every reuse project and every installation. However, any or all of these tools can be used to ensure the public is informed and on-board with water reuse initiatives (EPA, 1992).

## 10. ECONOMIC CONSIDERATIONS

Planners must consider a number of economic factors when attempting to fund and execute a water reuse project. Economics will often dictate the size, extent, and overall viability of a proposed project. Primary considerations include: (1) benefits, (2) reliability, (3) timing, and (4) optimization. Each is described below.

### 10.1. BENEFITS

The expected benefits of implementing a water reuse project are likely the most important consideration in an economic analysis. If a project is not cost effective, its chances for gaining approval and funding are limited, at best. While the fundamental goal of the Navy Water Conservation Program is to reduce water consumption on U.S. Naval facilities, the underlying impetus is cost reduction. If a project does not save the Government money, it will not succeed. That said, planners must clearly define and forecast the expected cost savings due to reduction in potable water demand, wastewater disposal costs, or both.

A number of scenarios exist where considerable economic gains can be made through water reuse. In water deficient areas (i.e. Western U.S.), decreased requirements for potable water will likely lead to significant cost savings. In many of these areas, the cost and associated restrictions for obtaining potable supplies often stifles growth and expansion. For example, it is nearly impossible to build golf courses in states like Arizona and California without a water reuse irrigation system. Another benefit holds in both water deficient and water rich areas. Due to population growth or stricter regulatory standards, upgrades or enlargement of wastewater treatment plants may be delayed if a portion of water is sent for reuse, instead of being discharged. Similarly, if present water sources are not adequate to meet growth rates and

demand, water reuse can be economically attractive. Water reuse options that result in low or no cost to the end user are also easier to implement. For example, providing tenant commands, such as MWR, with free irrigation water is often a selling point for a reuse project. Not only will their expenses be reduced, but also the base can ensure future availability of potable supplies for higher-priority or mission-oriented uses (Leeds, Hill, and Jewitt, 1971).

### 10.2. RELIABILITY

Reliability of the proposed project is another important consideration. The project must have sufficient storage, treatment redundancies, emergency power, and other features to ensure uninterrupted delivery of water. In water deficient areas, this is often less of an issue, due to the relative abundance of treated wastewater as compared to potable water. In water rich areas with excess capacity, however, reuse may be justified if costs can be shown to be less than the operating costs of potable treatment plants or existing wastewater treatment plants over the long term (Leeds, Hill, and Jewitt, 1971).

### 10.3. TIMING

Proper timing of a water reuse project is critical. To gain support, imminent or foreseeable problems with current operations or water supplies must be apparent. Examples include when water demands approach the limits of the existing system, increased municipal effluent quality requirements, or wastewater flows approaching system capacity. Another option is when new potential reclaimed water users decide to locate in the area, such as a new tenant command on the base with high projected water requirements. It is important that projects come

on line before or at the time when demand exceeds supply to realize the highest economic gain (Leeds, Hill, and Jewitt, 1971).

#### 10.4. OPTIMIZATION

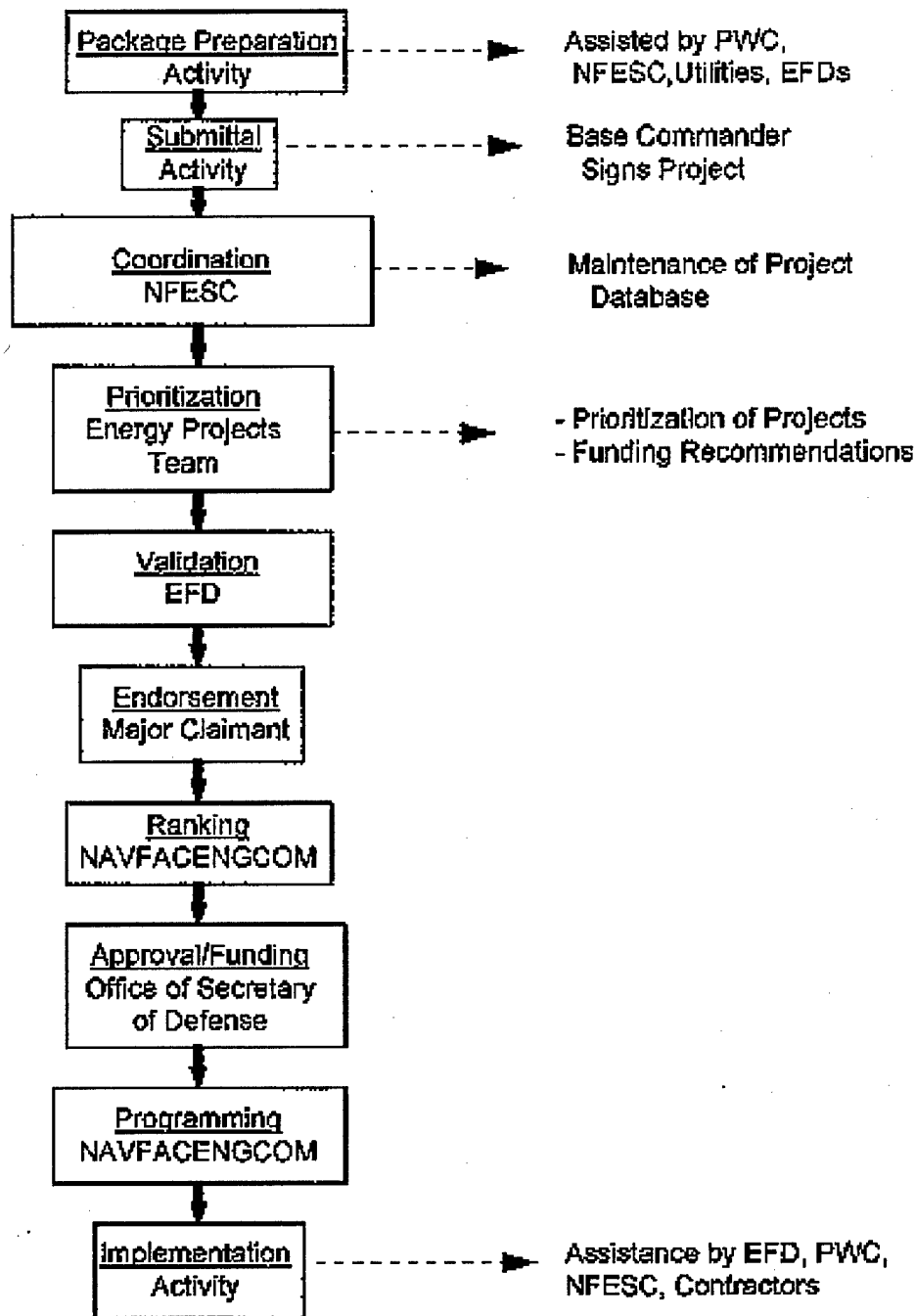
Optimization is the process of determining the appropriate size, extent, and configuration of a water reuse project based on associated costs for each option considered. In order to do this, a comparison must be made for marginal costs of serving potential users with reclaimed water versus potable supply. Marginal costs are defined as the average incremental costs required to meet water demand. This must include additional costs incurred due to using poorer quality water. For example, operating problems, additional treatment requirements, and increased maintenance may all result from water reuse. The costs associated with each of these items must be considered when comparing to operating and maintenance costs for potable use. If it is more economical to use potable supplies, a particular option becomes less attractive, and in many cases is ruled out (Leeds, Hill, and Jewitt, 1971).

## **11. IMPLEMENTING WATER REUSE PROJECTS**

There are four key steps for successful implementation of a proposed water reuse project. After the scope and cost estimates have been developed, the appropriate documentation must be prepared for submission to NAVFAC and funding must be obtained. As previously discussed, public education is a critical factor in a water reuse project's success. Education initiatives should begin in the planning process and continue well after the project has been executed. Finally, impacts of the water reuse project (cost savings, problems, etc.) should be monitored to determine if the system is operating as planned. If not, adjustments may need to be made to realize its full benefits. Each of the steps for project implementation is described below:

### **11.1. SUBMITTALS**

Once a project has been planned, it is important to begin the submittal process as soon as possible. Commands should allow at least six to eight weeks for approval by NAVFAC and another two to three months to receive funding. The project programming process is summarized in Figure 38 on the following page.



Note:

EFD = Engineering Field Division

NFESC = Naval Facilities Engineering Service Center

PWC = Public Works Center

NAVFACENGCOM = Naval Facilities Engineering Command

**Figure 38 - Water Conservation Project Programming Process (NFESC, 1993)**

In order for a project to be approved and funded, a Water Project Package must be developed by the originating activity. There are multiple parts of the package that must be prepared in accordance with NAVFAC guidelines. Each part is briefly described below. The *Navy Energy Manager's Handbook* and the *Navy Water Conservation Guide for Shore Activities* should be consulted for more detailed procedures when preparing a Water Project Package.

- Part 1 - Cover Letter, Summary Sheet and List of Attachments: The cover letter should be addressed from the activity commanding officer to Naval Facilities Engineering Service Center (Code 22) with a copy to the Engineering Field Division (EFD) and Major Claimant. The summary sheet includes a brief summary of the contents of the package and financial information from the Life Cycle Cost Analysis. Finally, a list of attachments is included after the summary sheet.

- Part 2 - DD Form 1391: The DD Form 1391 is the principal programming document used to initiate and track all Department of Defense projects. Detailed guidance for completing the DD Form 1391 can be found in NAVFACINST 11010.44E, the *Shore Facilities Planning Guide* and the *Navy Water Conservation Guide for Shore Activities*.

- Part 3 - Facility Study: A DD Form 1391c is used to complete the Facility Study. It includes 32 parts and should make reference to the Life Cycle Cost Analysis and categorical exclusions statement (Part 4). NAVFACINST 11010.44E provides specific guidance on completing the DD Form 1391c.

- Part 4 - Life Cycle Cost (LCC): The LCC Analysis performed for the project is included as Part 4 of the Water Project Package. The NAVFAC handbook, *P-442 Economic Analysis Handbook* is the standard reference for this process. NFESC has created a spreadsheet in

Microsoft Excel to make the Life Cycle Cost Analysis easier and standardize submissions.

Requests for an electronic copy of the spreadsheet should be made to NFESC (Code 221).

- Part 5 - Assumptions/ Categorical Exclusion Attachments: Any assumptions used when making technical calculations need to be listed in Part 5. Categorical exclusion statements are prepared for projects where an EIS is not required.
- Part 6 - Supporting Savings Calculations/Cost Estimates/ Audit Information Attachments: Part 6 should include relevant calculations, especially those used in the Life Cycle Cost Analysis. Other pertinent information from studies or audits that were conducted should also be included.
- Part 7 - Other Data and Information: Other relevant information not incorporated in Parts 1 through 6 should be included in Part 7. This includes salvage quotes, utility rate information, rebates, meteorological data, and other related information.
- Part 8 - Site Plan/ Building List: Maps and drawings, location lists, and other helpful site information should be included in Part 8.
- Part 9 - Points of Contact: Key points of contact for all aspects of the project should be included, along with the project developer and project recipient.
- Part 10 - References: Reference materials used to prepare the project package should be listed in Part 10.

The deadline for submitting project packages is March 30th. If current fiscal year funding is desired, the Water Project Package should be submitted no later than mid February. Key responsibilities of each of the organizations in the submittal chain are indicated on the following page:

**Organization**

**Responsibilities**

Originating Activity

- Prepare and submit water reuse project to Major Claimant or NFESC via the EFD.
- Develop a maintenance program for the proposed project.

EFD

- Perform technical evaluation on project package based on assumptions used, water and cost savings, and construction cost estimates.
- Assist in identifying, developing, and auditing centrally funded water reuse projects.
- Develop and execute contract package as requested by the originating activity.

Major Claimant

- Endorse validated projects based on future facility use and alignment with current policy guidelines.

NFESC

- Review project package for technical validity, adequate payback period, and SIR.
- Enter and maintain project data in computer database for tracking and reporting of project(s).
- Provide technical information and guidance to activities preparing water reuse project packages.

Energy Projects Team

- Composed of personnel from EFD, Public Works Center(s), NFESC, and NAVFAC.
- Prioritize proposed projects by SIR and payback period.
- Recommend projects to NAVFAC for funding.

NAVFAC

- Recommend projects to the Office of the Secretary of Defense (OSD) for programming/funding.
- Manage centralized funds to execute projects.
- Develop Navy-wide execution plan for water conservation (reuse) projects.

**Figure 39 - Organizational Responsibilities in the Water Conservation Project Submittal Process (NFESC, 1993)**

## 11.2. FUNDING

Large water reuse projects can be centrally funded using two funding programs managed by NAVFAC. They are the Energy Conservation Investment Program (ECIP) and the Federal Energy Management Program (FEMP). Large projects are defined as those costing more than \$50,000. Projects costing less than this amount must be funded by the individual activity and are considered "low cost/no cost" projects. All Navy activities are eligible to use ECIP funds for construction-type projects estimated at \$300,000 or more. ECIP projects must also require more than one year to execute and a substantial amount of design. FEMP funding is available for eligible projects that have not been funded by either ECIP or Major Claimant funds. Many water reuse projects will be covered under FEMP, since they are typically not construction in scope. Rather, they are often repair, maintenance, or equipment installation type projects.

Projects for Family Housing (FH) and Bureau of Medicine (BUMED) cannot be funded using ECIP or FEMP money. These projects can still be implemented, but are funded from separate accounts. For FH, water conservation retrofits can be programmed into the Whole House Repair Program and performed as part of other major renovations to reduce downtime of housing units.

In addition to being greater than \$50,000 in scope, projects must also have an acceptable SIR, a payback period of 10 years or less, meet Department of Defense funding obligation schedules, and reduce potable water consumption to be eligible for ECIP or FEMP funds. If FEMP funds are selected, they must be obligated in the same fiscal year in which approved. It is possible to combine multiple smaller projects into a larger project in order to meet central funding requirements. However, the projects must all have a common thread. Individual projects can all be within the same facility or at multiple facilities (NFESC, 1993).

### 11.3. BASE-WIDE EDUCATION

As described in Section 9.3, public opinion and involvement is a critical factor in a water reuse project's success. In order to ensure newly installed technologies are properly operated and maintained, and to prevent undue health risks to the affected population, base-wide education measures must be taken before, during, and after the project has been implemented. Many of the same approaches described in Section 9.3 can be used for base-wide education. Visual aids, such as posters, signs, flyers, videos, and demonstrations are helpful in conveying pertinent information about a water reuse system to large audiences. Facility occupants and maintenance staffs must be trained on the correct operating procedures and safeguards associated with water reuse measures. If there is a perception that the new system won't work as well, it is important to emphasize that with proper operation and maintenance, the same level and quality of service can be expected as with potable water (NFESC, 1993).

### 11.4. MONITORING RESULTS

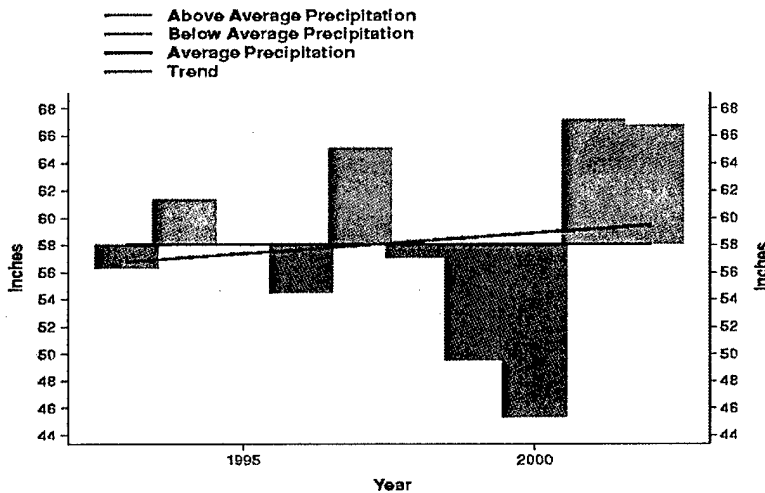
Periodic monitoring of the reuse measures implemented on a base is required to determine if they are working and to identify problems. The following actions should be included in a monitoring program (NFESC, 1993):

- Periodically check water usage for each device or system using reclaimed water. Results should be compared to pre-installation consumption.
- Evaluate trends in water and sewer bills. If water reuse measures are working properly, bills should reflect decreases in overall consumption and costs.
- Ensure that maintenance personnel are assigned to monitor and repair installed equipment, as needed.

## 12. CASE STUDY: NAVAL CONSTRUCTION BATTALION CENTER, GULFPORT, MS

The Naval Construction Battalion Center, Gulfport, MS (CBC Gulfport) is located on the Mississippi Gulf Coast within Gulfport city limits. Established in 1942, its mission is to provide logistical support, technical and military skills training, mobilization, and operational support to active and reserve units of the Naval Construction Force (NCF). CBC Gulfport is the fifth largest employer on the Mississippi Gulf Coast, with 4,392 employees as of April 2003 (HCDC, 2003).

As shown in the figure below (insert climate data chart), Mississippi received below average rainfall 5 years during the 10-year period between 1993 and 2003. The most severe shortages occurred during the years 1999 and 2000 (NCDC, 2003).



**Figure 40 - Mississippi Precipitation Statistics: 1993 to Present (NCDC, 2003)**

In addition, the Mississippi Gulf Coast experienced a 74% increase in population between 1990 and 2000 due to an influx of businesses and people related to the buildup of the gaming industry

along the coast (HCDC, 2003). These two factors combined put a significant strain on the area's potable water supply, which primarily comes from underground aquifers. Implementing water reuse measures at CBC Gulfport will help to ease the burden on the area's drinking water reserves, especially during dry periods and as a result of continued growth. This section explores potential water reuse options that can be put into practice at the base.

### 12.1. INSTALLATION OVERVIEW

CBC Gulfport occupies over 1,000 acres of land in southeastern Gulfport, MS. The base includes industrial, office, and storage facilities, family and bachelor housing, an 18-hole golf course, commissary, exchange, gymnasium, medical and dental clinics, chapel, museum, library, child development center, and numerous outdoor recreational facilities. No aircraft runways or port facilities exist on the base. An aerial photo of CBC Gulfport is shown below:



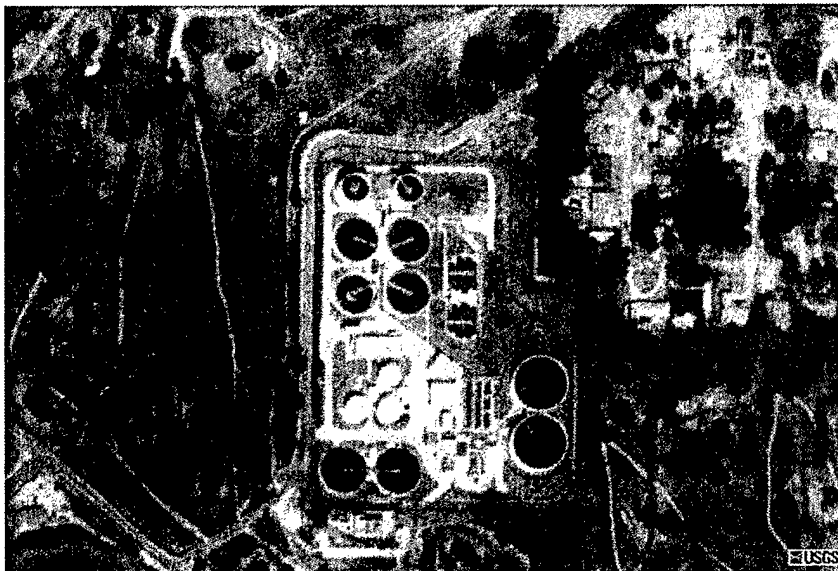
**Figure 41** - Aerial Photo of NCBC Gulfport, MS (USGS, 1992)

Potable water on the installation is drawn from underground wells and stored in an elevated gravity tank. There are also four connections to the City of Gulfport water supply to be used in case of emergency. Metered potable water use on the base averages around 260,000 gal/day (Norton, 2003). Sewage is piped off base via either of two outfalls and treated by the City of Gulfport. To date, no water reuse projects have been implemented at CBC Gulfport or in the local area. All users receive potable water, with exception of the golf course, which uses irrigation ponds to serve its water needs.

## 12.2. LOCAL WATER TREATMENT FACILITIES

The City of Gulfport operates two municipal wastewater treatment plants (WWTP), Gulfport South and Gulfport North. The Gulfport South plant treats domestic sewage from CBC Gulfport and the surrounding area. In the early 1990's the Gulfport South plant considered a water reuse project for irrigation at a local golf course, but the irrigation system was never installed, so the project never materialized.

The Gulfport South WWTP has a 10 MGD capacity and is located near the Gulfport/Biloxi International Airport on Washington Avenue. It discharges effluent near the southeastern shore of Bernard Bayou (Gulfport Lake). Influent is subject to pretreatment via screening and grit removal before primary sedimentation. Trickling filters are used for nitrogen removal and activated sludge is employed for BOD removal. After secondary sedimentation, the effluent is disinfected using chlorine gas before being discharged (Gatian, 2003). An aerial photograph of the Gulfport South WWTP is shown on the next page:



**Figure 42 - Aerial Photo of Gulfport South WWTP (USGS, 1992)**

Typical water quality parameters associated with the Gulfport South WWTP are listed below:

Parameter	CBC Gulfport Effluent (mg/L)	Influent Average (mg/L)	Influent Maximum (mg/L)	Effluent Average (mg/L)	Effluent Limit <sup>3</sup> (mg/L)
NH <sub>4</sub> <sup>+</sup> -N	24	11	13	0.4	0.8
Residual Cl <sub>2</sub>	0	0	0		0.0037
Fecal Coliforms <sup>1</sup>	TNTC <sup>4</sup>	TNTC <sup>4</sup>	TNTC <sup>4</sup>	12	19
BOD	107	126	169	6	8
TSS	100	142	236	9	10
Dissolved Oxygen					6.6
pH <sup>2</sup>	6.98			7.1	6.8
Oil and Grease	10				

**NOTES:**

1. Fecal coliforms are expressed as #/100 mL.
2. pH is a dimensionless quantity.
3. For all parameters except pH and dissolved oxygen, the effluent limit refers to the maximum concentration in the effluent. For dissolved oxygen and pH, it is the minimum value in the effluent.
4. TNTC means "too numerous to count."

**Figure 43 - Typical Water Quality at Gulfport South WWTP (Della-Volle, 2003)**

The Gulfport North WWTP has a 5 MGD capacity and serves the northern sections of Gulfport. It discharges at the upper end of Bernard Bayou near State Highway 49. Pretreatment consists of screening and grit removal. The water is then sent to an aerated lagoon (oxidation ditch). The lagoon operates under facultative (aerobic and anoxic) conditions to produce BOD and nitrogen removal. Suspended solids are removed via secondary clarification followed by sand filtration. Finally, the effluent is disinfected with UV radiation before being discharged (Gatian, 2003).

### 12.3. PROPOSED WATER REUSE APPLICATIONS

The most viable alternatives for water reuse at CBC Gulfport are golf course irrigation, recreational irrigation, and vehicle washracks. Options requiring treatment facilities to be constructed on the base have not been considered, due to the current trend in the U.S. Navy to privatize utility systems. As such, adding additional facilities on the base will require maintenance and upkeep by the government. Instead, it is more desirable to invest in private or public infrastructure (i.e. wastewater treatment plants) to make the necessary upgrades for water reuse.

Mississippi currently has no regulations governing water reuse. As such, all reuse options considered are judged against EPA recommended standards for unrestricted urban reuse. These are the most stringent criteria that EPA has set forth. Due to the high activity levels on CBC Gulfport and the desire for public approval, these strict standards are recommended. Further, this approach allows the most possible water reuse applications since high quality water can be used for projects requiring a lower quality, but not vice-versa. A comparison of CBC

Gulfport's effluent quality with that from the Gulfport South WWTP and EPA recommended standards is shown in the table below:

Parameter	CBC Gulfport Effluent (mg/L)	Effluent Limit <sup>3</sup> (mg/L)	EPA Recommended Standard <sup>5</sup> (mg/L)
NH <sub>4</sub> <sup>+</sup> -N	24	0.8	
Residual Cl <sub>2</sub>	0	0.0037	1
Fecal Coliforms <sup>1</sup>	TNTC <sup>4</sup>	19	14
BOD	107	8	10
TSS	100	10	5
Dissolved Oxygen		6.6	
PH <sup>2</sup>	6.98	6.8	6 – 9
Oil and Grease	10	No Data	
Turbidity <sup>6</sup>	No Data	No Data	2
TDS	No Data	No Data	500 – 2,000
Pathogens	No Data	No Data	Below Detectable Limits

**NOTES:**

1. Fecal coliforms are expressed as #/100 mL.
2. pH is a dimensionless quantity.
3. For all parameters except pH and dissolved oxygen, the effluent limit refers to the maximum concentration in the effluent. For dissolved oxygen and pH, it is the minimum value in the effluent.
4. TNTC means "too numerous to count."
5. EPA recommended water quality standards for unrestricted urban reuse (EPA, 1992).
6. Turbidity is expressed as NTU.

**Figure 44 - Comparison of Water Quality at Gulfport South WWTP to EPA Recommended Standards for Unrestricted Urban Reuse (Della-Volle, 2003; EPA, 1992)**

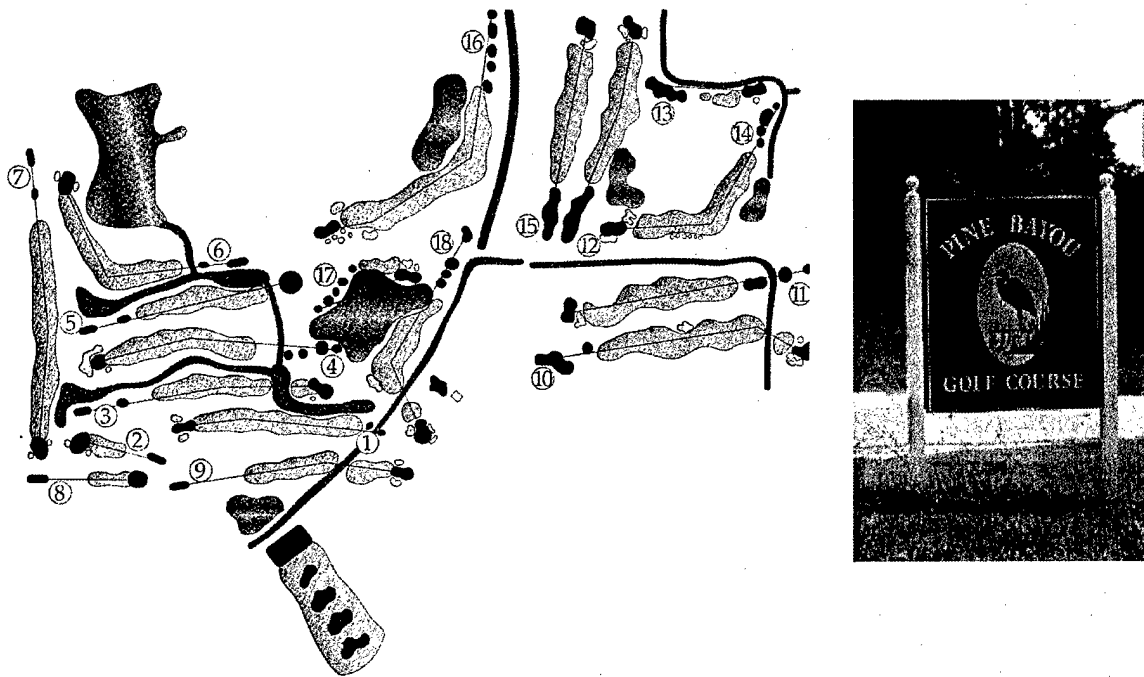
Each potential water reuse option is discussed in the following sub-sections. It is important to note that this is only a preliminary assessment, based on the data currently available.

A more detailed analysis of the Gulfport South WWTP effluent to determine the presence of inorganic contaminants listed in Section 6.1.1.1 is required to assess the effects of land

application of reclaimed water. Other issues to be considered are indicated in the ensuing discussions.

### 12.3.1. Golf Course Irrigation

The Pine Bayou Golf Course currently operates two manmade irrigation ponds, one for the front nine holes, and the other for the back nine holes. The front nine holes and their irrigation system were constructed in 1975. In 1998, the base added the back nine holes and the second irrigation pond. Appendices III and IV at the end of this report are the as-built irrigation systems for the front and back nine holes, respectively. All greens and fairways are planted with Bermuda grass. The overall golf course layout is pictured below:



**Figure 45 - Pine Bayou Golf Course (PBGC, 2003)**

During the drought years of 1999 and 2000, the golf course experienced substantial difficulties maintaining adequate storage in their irrigation ponds. This was due both to above-

average irrigation requirements and seepage losses from the ponds, which are not lined. In wetter years, the existing irrigation system had provided adequate water capacity. The golf course management approached the Public Works Department to install small potable water backup lines to feed the wet wells from which irrigation water was drawn. However, as the drought wore on, it became evident that the current system might not meet demand. It was at this point that the need for additional contingency water sources and/or improvements to the existing irrigation system became apparent.

Over the past 3 years, Mississippi has experienced higher than average precipitation, which has eased the burden on the golf course irrigation system. However, if and when another drought occurs, the base will be faced with the same dilemma over irrigation water shortages. Instead of augmenting the irrigation system with potable water as before, a strategy using treated secondary effluent from the Gulfport South WWTP should be considered. Secondary effluent from the Gulfport South WWTP meets EPA recommended criteria for unrestricted urban reuse, except for fecal coliforms, TSS, and chlorine residual. Fecal coliforms and TSS are slightly above recommended limits, while chlorine residual is much too low. Since Bermuda grass is considered tolerant to salinity in reclaimed wastewater, no additional treatment should be required to prevent salinity-related growth problems.

The recommended treatment strategy is to install slow sand filters following secondary clarification at the plant. Further, addition of coagulants (alum or ferric chloride) to the secondary clarifiers is recommended to increase suspended solids removal. This plan will also remove many of the inorganic contaminants described in Section 6.1.1.1. Lime addition is not recommended, due to high sludge generation and potential bicarbonate permeability problems. Slow sand filtration will serve as a polishing step to remove smaller particulates that pass

through the sedimentation process. Additional chlorination will be required to maintain the recommended 1 mg/L residual. However, chlorine can be toxic to fish living in the irrigation ponds. Dechlorination using sulfur dioxide may be performed after sufficient contact time has elapsed in order to meet disinfection requirements without maintaining a chlorine residual. However, the Mississippi Department of Environmental Quality (MDEQ) should be consulted before a dechlorination strategy is selected. Finally, if the above treatment strategy is implemented, no setbacks should be required to prevent public contact. MDEQ should also be consulted about this requirement.

The Gulfport South WWTP is approximately 7 miles northeast of CBC Gulfport. Water can be piped from the treatment plant to the base and discharged to either or both of the irrigation ponds on an as-needed basis. Flow controls and a booster station will be required at the treatment plant. An NPDES permit will be required, since "contaminated" water is being discharged into surface water body (the irrigation ponds), even if the pond water is of poorer quality than the treated effluent. However, this strategy will reduce the quantity of effluent discharged into Bernard Bayou by the treatment plant. Another benefit to using reclaimed secondary effluent to augment the golf course irrigation ponds is that they can be used as storage for other water reuse applications.

There are a host of other issues that must be considered if a water reuse project of this nature is to be realized. First, it is crucial that the irrigation ponds be drained and coated with impermeable liners to prevent continued water losses and potential groundwater contamination. This should be included as part of the scope for any water reuse project at the golf course. Further, laboratory studies using turf and soil samples should be done to measure the effects of secondary effluent application. An environmental risk analysis should also be performed to

determine any potential adverse effects on human health or the environment and their potential impacts. It is, however, anticipated that human health and environmental degradation risks associated with water reuse for golf course irrigation will be negligible. Finally, due to the scope of the project, it will likely exceed \$50,000, and therefore be eligible to receive Federal funding. As such, CBC Gulfport should strongly consider pursuing this or similar projects.

### *12.3.2. Recreational Field Irrigation*

Another water reuse option at CBC Gulfport is to use reclaimed water for recreational field irrigation. Numerous recreational fields exist on the base, which are regularly watered during the summer season. Water demand from irrigating these fields alone is probably not sufficient to justify a full-scale reuse project, but this application could easily be incorporated into a system for providing reclaimed water to the golf course. Integrating these two projects will have two benefits. First, the overall scope and cost of the combined project will almost certainly exceed the \$50,000 Federal funding cutoff. Second, increasing the scope provides additional justification to implement the project. Stated another way, increasing the demand for reclaimed water will further reduce the amount of secondary effluent discharged into Bernard Bayou and the quantity of potable water used on the base.

The easiest option would be to draw from one or both of the golf course irrigation ponds to irrigate the recreational fields. This will require additional irrigation piping to be installed from the storage ponds to the recreational fields to supply the sprinkler heads. Alternately, a separate branch from the incoming water main could be constructed solely for recreational irrigation uses instead of drawing from the ponds. The primary benefit of using the irrigation storage ponds as a source of water, both for the recreational fields and the golf course, is that demand varies by season and by the amount of rainfall received. Irrigation requirements are

largely dependent on the weather. In a wet year, little or no irrigation may be required, whereas during a drought, fields may be watered daily.

Similar considerations to those for the golf course will have to be made when planning to use reclaimed water for recreational field irrigation. Water quality guidelines and problems are essentially the same. As before, a laboratory analysis of the effects of reclaimed water on the grass and soil should be performed. Further, since recreational fields receive more traffic and access is less controlled as compared to a golf course, the risks associated with human exposure to contaminants will have to be closely studied. Golf courses typically irrigate at night or in the early morning hours, so as not to interrupt play. However, the recreational fields are often watered during the day. To minimize risk of exposure to reclaimed water, it may be prudent to adopt a similar watering schedule to that which the golf course uses.

### *12.3.3. Vehicle Washracks*

A number of vehicle washracks exist on the base, most of which are located in equipment maintenance areas. The most practical option for implementing a water reuse scheme is to use treated secondary municipal effluent from the Gulfport South WWTP. While an on-site treatment and reclamation system could be constructed, the cost and space requirements may be prohibitive, especially given the number of vehicles washed and frequency of washing. For a larger base, especially one that services aircraft, an on-site system might be justified.

As indicated in Section 5.1, the primary concern when using secondary effluent is pathogen and microorganism removal. A comparison of the recommended quality for vehicle washracks, effluent from the Gulfport South WWTP and EPA recommended standards for unrestricted urban reuse is shown on the following page:

Parameter	CBC Gulfport Effluent (mg/L)	Effluent Limit <sup>3</sup> (mg/L)	Recommended Quality for Vehicle Washracks <sup>7</sup> (mg/L)	EPA Recommended Standard <sup>5</sup> (mg/L)
NH <sub>4</sub> <sup>+</sup> -N	24	0.8	15	
Residual Cl <sub>2</sub>	0	0.0037	0	1
Fecal Coliforms <sup>1</sup>	TNTC <sup>4</sup>	19		14
BOD	107	8	20	10
TSS	100	10	60	5
Dissolved Oxygen		6.6		
pH <sup>2</sup>	6.98	6.8		6 – 9
Oil and Grease	10	No Data	5	
Turbidity <sup>6</sup>	No Data	No Data		2
TDS	No Data	No Data	100	500 – 2,000
Pathogens	No Data	No Data	Below Detectable Limits	Below Detectable Limits

**NOTES:**

1. Fecal coliforms are expressed as #/100 mL.
2. pH is a dimensionless quantity.
3. For all parameters except pH and dissolved oxygen, the effluent limit refers to the maximum concentration in the effluent. For dissolved oxygen and pH, it is the minimum value in the effluent.
4. TNTC means "too numerous to count."
5. EPA recommended water quality standards for unrestricted urban reuse (EPA, 1992).
6. Turbidity is expressed as NTU.
7. NFESC recommended water quality standards for vehicle and aircraft washing (NFESC, 1993).

**Figure 45 - Comparison of Water Quality at Gulfport South WWTP, EPA Recommended Standards for Unrestricted Urban Reuse, and Washrack Requirements (Della-Volle, 2003; NFESC, 1993; EPA, 1992)**

The treatment plant effluent meets all recommended quality standards for vehicle washing, based on the data available. Treating the water to meet EPA recommended guidelines should minimize the health risks associated with exposure to washrack water (i.e. misting, runoff, etc.). If a golf course and recreational field irrigation reuse system is implemented, treated water can also be used to supply vehicle washracks. In this case, it will be necessary to

create a separate storage tank for the washracks, instead of drawing directly from the irrigation ponds to prevent quality problems. A portion of the incoming water from the treatment plant can be diverted to storage for washrack use.

There are a number of issues surrounding water reuse for vehicle washracks, which must be addressed. Unlike irrigation, where water is applied when the chance for human contact is minimal (i.e. at night), vehicle washing takes place during the day when everyone is at work. As such, the probability of exposure to reclaimed water is significantly higher. With proper treatment, the risks to human health or the environment should be negligible. However, there may be concerns voiced by those operating or working around the facilities since they are likely to come into contact with the water at some point. Public education will be required to address water quality issues, health concerns, and to assure workers that the system is in fact safe. These issues will need to be considered in the risk analysis. Further, if enclosed storage is used, the potential for regrowth exists. Constant circulation and flushing of the storage tank to prevent stagnation is the most practical way to limit regrowth. Additional chlorination is not recommended, since chlorine can damage vehicle surfaces.

### 13. CONCLUSIONS AND RECOMMENDATIONS

Planning for water reuse on Navy installations requires a good deal of research, design, coordination, and foresight on the part of Navy facility and energy managers. The planning and implementation process is normally measured in years, rather than months. Preparing the required documentation, obtaining command, public, and local utility approval, and selecting the optimum design can often be cumbersome. Major planning factors include legal and regulatory considerations, treatment requirements, potential applications, risks to human health and the environment, public opinion, and cost. Each of these issues must be considered in the decision to implement a water reuse project. More exactly, they are used to balance the costs and benefits of particular water reuse applications on a given installation. This paper attempts to guide Navy facility and energy managers through the planning and implementation process by addressing many of the key issues that need to be considered. However, it is by no means all-inclusive. Each base has its own set of rules, operating conditions, and challenges. Further, each community will view water reuse differently. Factors such as climate, local economy, size of the Federal budget, and willingness to "think outside the box" will all impact the success of a proposed reuse project. Planners must not only consider the issues discussed in this paper, but rather put them into context as they apply to a particular installation.

Water reuse technologies have been in existence for almost 50 years. However, very few Navy installations have implemented projects of this nature. Many large communities around the U.S., along with the U.S. Army have been much more active in preparing guidance for and executing water reuse projects. In order for the Navy to become more involved in water reuse initiatives, a number of things need to happen. First, Navy facility and energy managers need to be educated on water reuse. Much of the guidance prepared by the Navy Energy Management

and Water Conservation Programs only briefly addresses this option. As stated at the beginning of this report, there is no comprehensive water reuse planning guidance for Navy facilities. As such, managers have to rely on a select few individuals within NAVFAC who have experience with these projects. This paper attempts to establish baseline guidance, but must first be endorsed by NAVFAC before widespread distribution can occur. In the interim, training sessions and seminars for facility and energy managers should be held to "get the word out" about the benefits of water reuse. Second, public perceptions about water reuse need to be evaluated. Many people are reluctant to accept reclaimed water as a viable alternative to potable water. Concerns from command staff, base workforce, residents, and others who utilize affected facilities should be addressed in public forums through literature and/or briefings to solicit input and allay fears. Fostering positive opinions or even enthusiasm about water reuse can be critical to any project's success. All Navy facilities should consider water reuse as a possible water conservation measure. They should evaluate existing water conservation plans and facility audits to determine where water reuse applications can be employed. This is especially true for bases in the Western U.S. and other arid areas, where potable supplies are limited, expensive, and highly contested.

***APPENDIX I - GLOSSARY***

## GLOSSARY

- Alkalinity: Alkalinity is defined as the total concentration of hydroxide and carbonate species in a wastewater sample as follows:

$$\text{Alkalinity} = [\text{OH}^-] + [\text{H}_2\text{CO}_3] + [\text{HCO}_3^-] + 2[\text{CO}_3^{2-}]$$

Alkalinity helps to buffer changes in the pH of a water due to acid addition. It is typically reported as milligrams of calcium carbonate per liter (mg CaCO<sub>3</sub>/L).

- Biochemical Oxygen Demand (BOD): BOD refers to a test used to determine the dissolved oxygen utilized by microorganisms in a water sample to oxidize organic matter. Results from the BOD test are normally reported after a 5-day incubation period, since approximately 60 to 70 percent of the dissolved oxygen in the sample has been used. A first order decay relationship is used to estimate the BOD at equilibrium (called ultimate BOD) or at other times (Metcalf and Eddy, 2003). In this report, BOD refers to the 5-day BOD or BOD<sub>5</sub>, which is the standard parameter reported for most EPA and state regulatory requirements.

- Blackwater: Water that is discharged from toilets, urinals, dishwashers, kitchen sinks, and similar appliances. It contains food, human wastes, and other organic matter (NFESC, 1993).

- Chemical Oxygen Demand (COD): The COD test is used to determine the organic content of a wastewater sample. A strong oxidizing agent (normally potassium dichromate (K<sub>2</sub>Cr<sub>2</sub>O<sub>7</sub>) is used to oxidize the organic matter and the equivalent amount of oxygen required is calculated (Metcalf and Eddy, 2003).

- Greywater: Greywater includes water discharged from bathroom sinks, washing machines, and showers in a residential or commercial building. Primary contaminants include dirt, soap, and detergents (NFESC, 1993).

- Reclaimed Water: Water that is treated before reuse. Most water reuse applications use reclaimed water (NFESC, 1993).
- Recycled Water: Water that is reused with little or no treatment (NFESC, 1993).
- Secondary Municipal Effluent: Secondary municipal effluent is domestic wastewater that has been treated to remove solids, organic matter, nutrients, and pathogens to meet state or federal permit requirements for discharge to surface water bodies. Treatment typically includes pre-treatment, primary sedimentation, aerobic biological treatment, secondary sedimentation, and disinfection. Secondary municipal effluent is also referred to as secondary effluent.
- Total Dissolved Solids (TDS): Total dissolved solids calculated as the difference between total solids (measured in a laboratory as the residue in a dish after evaporation at 105°C) and total suspended solids (see definition for TSS). Technically this calculation includes both dissolved and colloidal solids, but the latter cannot easily be removed without additional treatment (Metcalf and Eddy, 2003).
- Total Organic Carbon (TOC): Total Organic Carbon is a measure of the quantity of organic matter present in a wastewater sample. It is analyzed by burning a sample in a furnace and measuring the carbon dioxide produced from combustion (Metcalf and Eddy, 2003).
- Total Suspended Solids (TSS): Total suspended solids are measured in a laboratory using an Imhoff Cone followed by a Whatman GF/C filter with a pore size of 1.2 µm. A wastewater sample is placed in the Imhoff Cone for 60 minutes. The solids collected at the bottom of the cone are termed "settleable solids" and are an estimate of the sludge removed by primary sedimentation. The sample is then filtered using the Whatman GF/C apparatus. After evaporation at 105°C, the residue on the filter is measured and classified as TSS (Metcalf and Eddy, 2003).

- Turbidity: Turbidity is a measure of a water's ability to transmit light. The presence of suspended matter will reduce light transmission and make the water look more opaque.

Turbidity is typically used as an indicator of suspended solids content in secondary municipal effluent (Metcalf and Eddy, 2003).

- Water Reuse: Water reuse refers to use of secondary municipal effluent, greywater, or other non-potable sources that have been used one or more times for a particular process or application. Water reuse is typically done in place of using fresh potable water to meet process needs.

***APPENDIX II - EPA RECOMMENDED  
GUIDELINES FOR WATER REUSE***

Table 2B. Suggested Guidelines for Water Reuse<sup>1</sup> (Page 1 of 6)

Types of Reuse	Treatment	Reclaimed Water Quality <sup>2</sup>	Reclaimed Water Monitoring	Setback Distances <sup>3</sup>	Comments
<p><b>Urban Reuse</b></p> <p>All types of landscape irrigation, (e.g., golf courses, parks, cemeteries) —also vehicle washing, retail washing, use in fire protection systems and commercial air conditioning, and other uses with similar access or exposure to the water.</p>	<ul style="list-style-type: none"> <li>Secondary<sup>4</sup></li> <li>Filtration<sup>5</sup></li> <li>Disinfection<sup>6</sup></li> </ul>	<ul style="list-style-type: none"> <li>pH = 6 - 9</li> <li>≤ 10 mg/l BOD<sup>7</sup></li> <li>≤ 2 NTU<sup>8</sup></li> <li>No detectable<sup>9,10</sup> fecal coliforms</li> <li>1 mg/l Cl<sub>2</sub> residual (min.)<sup>11</sup></li> </ul>	<ul style="list-style-type: none"> <li>pH - weekly</li> <li>BOD - weekly</li> <li>Turbidity - continuous</li> <li>Coliform - daily</li> <li>Cl<sub>2</sub> residual - continuous</li> </ul>	<ul style="list-style-type: none"> <li>50 ft (15 m) to potable water supply wells</li> </ul>	<ul style="list-style-type: none"> <li>See Table 19 for other recommended limits.</li> <li>At controlled-access irrigation sites where design and operational measures significantly reduce the potential of public contact with reclaimed water, a lower level of treatment, e.g., secondary treatment and disinfection to achieve a 14 day contact time, may be appropriate.</li> <li>Chemical (coagulant and/or polymer) addition prior to filtration may be necessary to meet water quality recommendations.</li> <li>The reclaimed water should not contain measurable levels of pathogens.<sup>12</sup></li> <li>Reclaimed water should be clear, odorless, and contain no substances that are toxic upon ingestion.</li> <li>A higher chlorine residual and/or a longer contact time may be necessary to assure that viruses and parasites are inactivated or destroyed.</li> <li>A chlorine residual of 0.5 mg/l or greater in the distribution system is recommended to reduce odors, films, and bacterial regrowth.</li> <li>See Section 2.4.3. for recommended treatment reliability.</li> </ul>
<p><b>Restricted Access Area Irrigation</b></p> <p>Sod farms, athletic fields, and other areas where public access is prohibited, restricted, or infrequent.</p>	<ul style="list-style-type: none"> <li>Secondary<sup>4</sup></li> <li>Disinfection<sup>6</sup></li> </ul>	<ul style="list-style-type: none"> <li>pH = 6 - 9</li> <li>≤ 30 mg/l BOD<sup>7</sup></li> <li>≤ 30 mg/l SS</li> <li>≤ 200 fecal coliforms / 100 ml<sup>9,10,14</sup></li> <li>1 mg/l Cl<sub>2</sub> residual (min.)<sup>11</sup></li> </ul>	<ul style="list-style-type: none"> <li>pH - weekly</li> <li>BOD - weekly</li> <li>SS - daily</li> <li>Coliform - daily</li> <li>Cl<sub>2</sub> residual - continuous</li> </ul>	<ul style="list-style-type: none"> <li>300 ft (90 m) to potable water supply wells</li> <li>100 ft (30 m) to areas accessible to the public (if spray irrigation)</li> </ul>	<ul style="list-style-type: none"> <li>See Table 19 for other recommended limits.</li> <li>If spray irrigation, SS less than 30 mg/l may be necessary to avoid clogging of sprinkler heads.</li> <li>See Section 2.4.3 for recommended treatment reliability.</li> </ul>
<p><b>Agricultural Reuse - Food Crops Not Commercially Processed<sup>15</sup></b></p> <p>Surface or spray irrigation of any food crops, including crops eaten raw.</p>	<ul style="list-style-type: none"> <li>Secondary<sup>4</sup></li> <li>Filtration<sup>5</sup></li> <li>Disinfection<sup>6</sup></li> </ul>	<ul style="list-style-type: none"> <li>pH = 6 - 9</li> <li>≤ 10 mg/l BOD<sup>7</sup></li> <li>≤ 2 NTU<sup>8</sup></li> <li>No detectable<sup>9,10</sup> fecal coliforms</li> <li>1 mg/l Cl<sub>2</sub> residual (min.)<sup>11</sup></li> </ul>	<ul style="list-style-type: none"> <li>pH - weekly</li> <li>BOD - weekly</li> <li>Turbidity - continuous</li> <li>Coliform - daily</li> <li>Cl<sub>2</sub> residual - continuous</li> </ul>	<ul style="list-style-type: none"> <li>50 ft (15 m) to potable water supply wells</li> </ul>	<ul style="list-style-type: none"> <li>See Table 19 for other recommended limits.</li> <li>Chemical (coagulant and/or polymer) addition prior to filtration may be necessary to meet water quality recommendations.</li> <li>This reclaimed water should not contain measurable levels of pathogens.<sup>12</sup></li> <li>A higher chlorine residual and/or a longer contact time may be necessary to assure that viruses and parasites are inactivated or destroyed.</li> <li>High nutrient levels may adversely affect some crops during certain growth stages.</li> <li>See Section 2.4.3 for recommended treatment reliability.</li> </ul>

Table 28. Suggested Guidelines for Water Reuse<sup>1</sup> (Page 2 of 6)

Types of Reuse	Treatment	Reclaimed Water Quality <sup>2</sup>	Reclaimed Water Monitoring	Setback Distances <sup>3</sup>	Comments
<b>Agricultural Reuse</b> - Food Crops - Commercial Processing, <sup>10</sup> - Surface Irrigation of Orchards and Vineyards	<ul style="list-style-type: none"> <li>Secondary<sup>4</sup></li> <li>Disinfection<sup>5</sup></li> </ul>	<ul style="list-style-type: none"> <li>pH = 6 - 9</li> <li>≤ 30 mg/l BOD<sup>7</sup></li> <li>≤ 30 mg/l SS</li> <li>≤ 200 fecal coliform/100 ml</li> <li>1 mg/l Cl<sub>2</sub> residual (min.)<sup>11</sup></li> </ul>	<ul style="list-style-type: none"> <li>pH - weekly</li> <li>BOD - weekly</li> <li>SS - daily</li> <li>Coliform - daily</li> <li>Cl<sub>2</sub> residual - continuous</li> </ul>	<ul style="list-style-type: none"> <li>300 ft (90 m) to potable water supply wells</li> <li>100 ft (30 m) to areas accessible to the public</li> </ul>	<ul style="list-style-type: none"> <li>See Table 19 for other recommended limits.</li> <li>If spray irrigation, SS less than 30 mg/l may be necessary to avoid clogging of sprinkler heads.</li> <li>High nutrient levels may adversely affect some crops during certain growth stages.</li> <li>See Section 2.4.3 for recommended treatment reliability.</li> </ul>
<b>Agricultural Reuse</b> - Non-Food Crops - Pasture for milking animals, fodder, fiber and seed crops	<ul style="list-style-type: none"> <li>Secondary<sup>4</sup></li> <li>Disinfection<sup>5</sup></li> </ul>	<ul style="list-style-type: none"> <li>pH = 6 - 9</li> <li>≤ 30 mg/l BOD<sup>7</sup></li> <li>≤ 30 mg/l SS</li> <li>≤ 200 fecal coliform/100 ml</li> <li>1 mg/l Cl<sub>2</sub> residual (min.)<sup>11</sup></li> </ul>	<ul style="list-style-type: none"> <li>pH - weekly</li> <li>BOD - weekly</li> <li>SS - daily</li> <li>Coliform - daily</li> <li>Cl<sub>2</sub> residual - continuous</li> </ul>	<ul style="list-style-type: none"> <li>300 ft (90 m) to potable water supply wells</li> <li>100 ft (30 m) to areas accessible to the public (if spray irrigation)</li> </ul>	<ul style="list-style-type: none"> <li>See Table 19 for other recommended limits.</li> <li>If spray irrigation, SS less than 30 mg/l may be necessary to avoid clogging of sprinkler heads.</li> <li>High nutrient levels may adversely affect some crops during certain growth periods.</li> <li>Milking animals should be prohibited from grazing for 15 days after irrigation ceases. A higher level of disinfection, e.g., to achieve at least 100/100 ml, should be provided if this waiting period is not achieved.</li> <li>See Section 2.4.3 for recommended treatment reliability.</li> </ul>
<b>Recreational Impoundments</b> - Incidental contact (e.g., fishing and boating) and full body contact with reclaimed water allowed	<ul style="list-style-type: none"> <li>Secondary<sup>4</sup></li> <li>Filtration<sup>5</sup></li> <li>Disinfection<sup>6</sup></li> </ul>	<ul style="list-style-type: none"> <li>pH = 6 - 9</li> <li>≤ 10 mg/l BOD<sup>7</sup></li> <li>≤ 2 NTU<sup>8</sup></li> <li>No detectable fecal coliform/ml<sup>10</sup></li> <li>1 mg/l Cl<sub>2</sub> residual (min.)<sup>11</sup></li> </ul>	<ul style="list-style-type: none"> <li>pH - weekly</li> <li>BOD - weekly</li> <li>Turbidity - continuous</li> <li>Coliform - daily</li> <li>Cl<sub>2</sub> residual - continuous</li> </ul>	<ul style="list-style-type: none"> <li>500 ft (150 m) to potable water supply wells (minimum) if bottom not sealed</li> </ul>	<ul style="list-style-type: none"> <li>Disinfection may be necessary to protect aquatic species of fish and fauna.</li> <li>Reclaimed water should be non-irritating to skin and eyes.</li> <li>Reclaimed water should be clear, colorless, and contain no substances that are toxic upon ingestion.</li> <li>Nutrient removal may be necessary to avoid algae growth in impoundments.</li> <li>Chemical (residual and/or polymer) addition prior to filtration may be necessary to meet water quality recommendations.</li> <li>The reclaimed water should not contain measurable levels of pathogens.<sup>9</sup></li> <li>A higher chlorine residual and/or a longer contact time may be necessary to assure that viruses and parasites are inactivated or destroyed.</li> <li>Fish caught in impoundments can be consumed.</li> <li>See Section 2.4.3 for recommended treatment reliability.</li> </ul>

Table 2B. Suggested Guidelines for Water Reuse<sup>1</sup> (Page 3 of 8)

Type of Reuse	Treatment	Reclaimed Water Quality <sup>2</sup>	Reclaimed Water Monitoring	Setback Distance <sup>3</sup>	Comments
Landscape Irrigations Aesthetic Impoundment where public contact with reclaimed water is not allowed	Secondary <sup>4</sup> Disinfection <sup>5</sup>	• 5.00 mg/l BOD <sup>7</sup> • 5.00 mg/l SS • 5.200 fecal col/100 ml <sup>8,13,14</sup> • 1 mg/l Cl <sub>2</sub> residual (min.) <sup>11</sup>	• pH - weekly • SS - daily • Coliform - daily • Cl <sub>2</sub> residual - continuous	• 500 ft (150 m) to public water supply wells (minimum if bottom not sealed)	• Nutrient removal processes may be necessary to avoid algae growth in impoundments. • Disinfection may be necessary to protect aquatic species of fish and birds. • See Section 2.4.3 for recommended treatment reliability.
Construction Uses Soil compaction, dust control, washing aggregate, making concrete	Secondary <sup>4</sup> Disinfection <sup>5</sup>	• 5.00 mg/l BOD <sup>7</sup> • 5.00 mg/l SS • 5.200 fecal col/100 ml <sup>8,13,14</sup> • 1 mg/l Cl <sub>2</sub> residual (min.) <sup>11</sup>	• BOD - weekly • SS - daily • Coliform - daily • Cl <sub>2</sub> residual - continuous		• Worker contact with reclaimed water should be minimized. • A higher level of disinfection, e.g., to achieve 5.14 fecal col/100 ml, should be provided where frequent worker contact with reclaimed water is likely. • See Section 2.4.3 for recommended treatment reliability.
Industrial Reuse Once-through cooling	Secondary <sup>4</sup>	• pH = 6 - 9 • 5.00 mg/l BOD <sup>7</sup> • 5.00 mg/l SS • 5.200 fecal col/100 ml <sup>8,13,14</sup> • 1 mg/l Cl <sub>2</sub> residual (min.) <sup>11</sup>	• pH - daily • BOD - weekly • SS - weekly • Coliform - daily • Cl <sub>2</sub> residual - continuous	• 300 ft (90 m) to areas accessible to the public	• Windblown spray should not reach areas accessible to users of the public.
Refrigerating cooling towers	Secondary <sup>4</sup> Disinfection <sup>5</sup> (chemical coagulation and filtration may be needed)	• Variable, depends on recirculation ratio (see Section 3.3.1)		• 300 ft (90 m) to areas accessible to the public. May be reduced if high level of disinfection is provided.	• Windblown spray should not reach areas accessible to the public. • See Table 13 for additional recommended limits. • Additional treatment by user is usually provided to prevent scaling, corrosion, biological growth, fouling and foaming. • See Section 2.4.3 for recommended treatment reliability.
Other Industrial Uses			Depends on site specific use (See Sections 3.3.2 and 3.3.3)		
Environmental Reuse Wetlands, marshes, wildlife habitat, stream augmentation	Variable Secondary <sup>4</sup> and disinfection <sup>5</sup> (min.)	• Variable, but not to exceed: • 5.00 mg/l BOD <sup>7</sup> • 5.00 mg/l SS • 5.200 fecal col/100 ml <sup>8,13,14</sup>	• BOD - weekly • SS - daily • Coliform - daily • Cl <sub>2</sub> residual - continuous		• Disinfection may be necessary to protect aquatic species of fish and birds. • Possible effects on groundwater should be evaluated. • Receiving water quality requirements may necessitate additional treatment. • The temperature of the reclaimed water should not adversely affect ecosystem. • See Section 2.4.3 for recommended treatment reliability.

Table 24. Suggested Guidelines for Water Reuse<sup>1</sup> (Page 4 of 6)

Type of Reuse	Treatment	Reclaimed Water Quality <sup>2</sup>	Reclaimed Water Monitoring	Distance to Point of Withdrawal	Comments
<p>Groundwater Recharge</p> <p>By spreading or injection into nonpotable aquifers</p>	<ul style="list-style-type: none"> <li>Site specific and use dependent</li> <li>Primary (min.) for spreading</li> <li>Secondary (min.) for injection</li> </ul>	<ul style="list-style-type: none"> <li>Site specific and use dependent</li> </ul>	<ul style="list-style-type: none"> <li>Depends on treatment and use</li> </ul>	<ul style="list-style-type: none"> <li>Site specific</li> </ul>	<ul style="list-style-type: none"> <li>Facility should be designed to ensure that no reclaimed water reaches potable water supply aquifers.</li> <li>See Section 3.5 for more information.</li> <li>For injection project, filtration and disinfection may be needed to prevent clogging.</li> <li>See Section 2.4.3 for recommended treatment reliability.</li> </ul>
<p>Indirect Potable Reuse</p> <p>Groundwater recharge by spreading into potable aquifers</p>	<ul style="list-style-type: none"> <li>Site specific</li> <li>Secondary<sup>4</sup> and tertiary<sup>5</sup> (min.) May also need filtration<sup>3</sup> and/or advanced wastewater treatment<sup>6</sup></li> </ul>	<ul style="list-style-type: none"> <li>Site specific</li> <li>Meet drinking water standards after percolation through vadose zone</li> </ul>	<ul style="list-style-type: none"> <li>Includes, but not limited to, the following:                             <ul style="list-style-type: none"> <li>pH - daily</li> <li>Coliform - daily</li> <li>Cl<sub>2</sub> residual - continuous</li> <li>Drinking water standards - quarterly</li> <li>Other<sup>7</sup> depends on constituent</li> </ul> </li> </ul>	<ul style="list-style-type: none"> <li>2000 ft (600 m) to extraction wells, may vary depending on treatment provided and site-specific conditions.</li> </ul>	<ul style="list-style-type: none"> <li>The depth to groundwater (i.e., thickness of the vadose zone) should be at least 5 feet (2m) at the maximum groundwater recharging point.</li> <li>The reclaimed water should be retained underground for at least 1 year prior to withdrawal.</li> <li>Recommended treatment is site-specific and depends on factors such as type of soil, percolation rate, thickness of vadose zone, native groundwater quality, and dilution.</li> <li>Monitoring wells are necessary to detect the influence of the recharge operation on the groundwater.</li> <li>See Sections 3.5 and 3.7 for more information.</li> <li>The reclaimed water should not contain measurable levels of pathogens after percolation through the vadose zone. It</li> <li>See Section 2.4.3. for recommended treatment reliability.</li> </ul>
<p>Groundwater recharge by injection into potable aquifers</p>	<ul style="list-style-type: none"> <li>Secondary<sup>4</sup></li> <li>Filtration<sup>3</sup></li> <li>Disinfection<sup>5</sup></li> <li>Advanced wastewater treatment<sup>6</sup></li> </ul>	<ul style="list-style-type: none"> <li>Includes, but not limited to, the following:                             <ul style="list-style-type: none"> <li>pH = 6.5 - 8.5</li> <li>5.2 NTU<sup>8</sup></li> <li>No detectable fecal coliform<sup>9,10</sup></li> <li>1 mg/L Cl<sub>2</sub> residual (min.)<sup>11</sup></li> <li>Meet drinking water standards</li> </ul> </li> </ul>	<ul style="list-style-type: none"> <li>Includes, but not limited to, the following:                             <ul style="list-style-type: none"> <li>pH - daily</li> <li>Turbidity - continuous</li> <li>Coliform - daily</li> <li>Cl<sub>2</sub> residual - continuous</li> <li>Drinking water standards - quarterly</li> <li>Other<sup>12</sup> depends on constituent</li> </ul> </li> </ul>	<ul style="list-style-type: none"> <li>2000 ft (600m) to extraction wells. May vary depending on site-specific conditions.</li> </ul>	<ul style="list-style-type: none"> <li>The reclaimed water should be retained underground for at least 1 year prior to withdrawal.</li> <li>Monitoring wells are necessary to detect the influence of the recharge operation on the groundwater.</li> <li>Recommended quality limits should be met at the point of injection.</li> <li>The reclaimed water should not contain measurable levels of pathogens at the point of injection.<sup>13</sup></li> <li>See Sections 3.5 and 3.7 for more information.</li> <li>A higher chlorine residual and/or a longer contact time may be necessary to assure virus inactivation.</li> <li>See Section 2.4.3. for recommended treatment reliability.</li> </ul>

Table 28. Suggested Guidelines for Water Reuse<sup>1</sup> (Page 5 of 6)

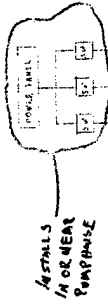
Types of Reuse	Treatment	Reclaimed Water Quality <sup>2</sup>	Reclaimed Water Monitoring	Distance to Point of Withdrawal	Comments
<ul style="list-style-type: none"> <li>• Indirect Potable Reuse</li> <li>• Augmentation of surface supplies</li> </ul>	<ul style="list-style-type: none"> <li>• Secondary<sup>4</sup></li> <li>• Filtration<sup>5</sup></li> <li>• Disinfection<sup>6</sup></li> <li>• Advanced wastewater treatment<sup>18</sup></li> </ul>	<ul style="list-style-type: none"> <li>• Includes, but not limited to, the following:               <ul style="list-style-type: none"> <li>• pH = 6.5 - 8.5</li> <li>• ≤ 2 NTU<sup>9</sup></li> <li>• No detectable fecal coliform (MCF)<sup>10</sup></li> <li>• 1 mg/l Cl<sub>2</sub> residual (min.)<sup>11</sup></li> <li>• Meet drinking water standards.</li> </ul> </li> </ul>	<ul style="list-style-type: none"> <li>• Includes, but not limited to, the following:               <ul style="list-style-type: none"> <li>• pH - daily</li> <li>• Turbidity - continuous</li> <li>• Coliform - daily</li> <li>• Cl<sub>2</sub> residual - continuous</li> <li>• Drinking water standards - quarterly</li> <li>• Other<sup>17</sup> depends on consultant</li> </ul> </li> </ul>	<ul style="list-style-type: none"> <li>• Site specific</li> </ul>	<ul style="list-style-type: none"> <li>• Recommended level of treatment is site-specific and depends on factors such as receiving water quality, time and distance to point of withdrawal, effluent and subsequent treatment prior to distribution for potable uses.</li> <li>• The reclaimed water should not contain measurable levels of pathogens.<sup>12</sup></li> <li>• See Section 3.7 for more information.</li> <li>• A higher chlorine residual and/or a longer contact time may be necessary to assure virus inactivation.</li> <li>• See Section 2.4.3 for recommended treatment reliability.</li> </ul>

Table 2b. Suggested Guidelines for Water Reuse<sup>1</sup> (Page 6 of 6)

Footnotes:

1. These guidelines are based on water reclamation and reuse practices in the U.S., and they are especially directed at states that have not developed their own regulations or guidelines. While the guidelines should be useful in many areas outside the U.S., local conditions may limit the applicability of the guidelines in some countries (see Chapter 8). It is explicitly stated that the direct application of these suggested guidelines will not be used by AED as strict criteria for funding.
2. Unless otherwise noted, recommended quality limits apply to the reclaimed water at the point of discharge from the treatment facility.
3. Setback distances are recommended to protect potable water supply sources from contamination and to protect humans from unacceptable health risks due to exposure to reclaimed water.
4. Secondary treatment processes include activated sludge processes, trickling filters, rotating biological contactors, and many stabilization pond systems. Secondary treatment should produce effluent in which both the BOD and SS do not exceed 30 mg/l.
5. Filtration means the passing of wastewater through natural and/or synthetic beds of filter media such as sand and/or anthracite.
6. Disinfection means the disinfection, inactivation, or removal of pathogenic microorganisms by chemical, physical, or biological means. Disinfection may be accomplished by chlorination, ozonation, other chemical disinfectants, UV radiation, membrane processes, or other processes.
7. As determined from the 5-day BOD test.
8. The recommended turbidity limit should be met prior to disinfection. The average turbidity should be based on a 24-hour time period. The turbidity should not exceed 5 NTU at any time. If SS is used in lieu of turbidity, the average SS should not exceed 5 mg/l.
9. Unless otherwise noted, recommended coliform limits are median values determined from the bacteriological results of the last 7 days for which analyses have been completed. Either the membrane filter or fermentation tube technique may be used.
10. The number of fecal coliform organisms should not exceed 140/100 ml in any sample.
11. Total chlorine residual after a minimum contact time of 30 minutes.
12. It is preferable to fully characterize the microbiological quality of the reclaimed water prior to implementation of a reuse program.
13. The number of fecal coliform organisms should not exceed 800/100 ml in any sample.
14. Some stabilization pond systems may be able to meet this coliform limit without disinfection.
15. Commercially processed food crops are those that, prior to sale to the public or others, have undergone chemical or physical processing sufficient to destroy pathogens.
16. Advanced wastewater treatment processes include chemical disinfection, carbon adsorption, reverse osmosis and other membrane processes, air stripping, ultrafiltration, and ion exchange.
17. Monitoring should include inorganic and organic compounds, or classes of compounds, that are known or suspected to be toxic, carcinogenic, teratogenic, or mutagenic and are not included in the drinking water standards.

***APPENDIX III - IRRIGATION SYSTEM***  
***FOR THE FRONT NINE HOLES AT PINE***  
***BAYOU GOLF COURSE, NCBC***  
***GULFPORT, MS***



ZONE	CONTRACT NO.	DATE
1	11-487	11-487
2	31-97	31-97
3	31-97	31-97
4	52-70	52-70
5	52-70	52-70
6	52-70	52-70
7	52-70	52-70
8	52-70	52-70
9	52-70	52-70
10	52-70	52-70
11	52-70	52-70
12	52-70	52-70
13	52-70	52-70
14	52-70	52-70
15	52-70	52-70
16	52-70	52-70
17	52-70	52-70
18	52-70	52-70
19	52-70	52-70
20	52-70	52-70

ZONE	CONTRACT NO.	DATE
1	11-487	11-487
2	31-97	31-97
3	31-97	31-97
4	52-70	52-70
5	52-70	52-70
6	52-70	52-70
7	52-70	52-70
8	52-70	52-70
9	52-70	52-70
10	52-70	52-70
11	52-70	52-70
12	52-70	52-70
13	52-70	52-70
14	52-70	52-70
15	52-70	52-70
16	52-70	52-70
17	52-70	52-70
18	52-70	52-70
19	52-70	52-70
20	52-70	52-70

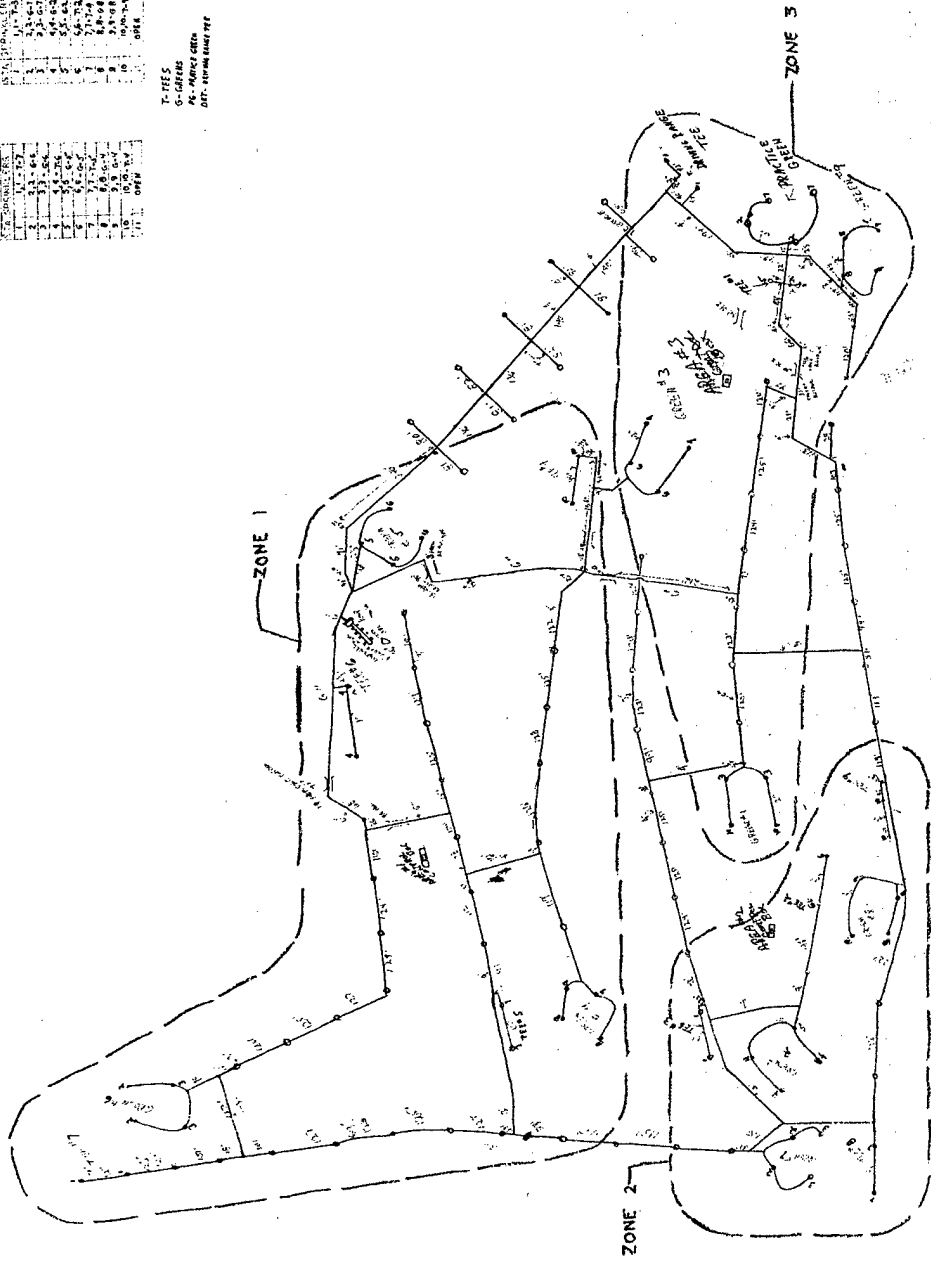
ZONE	CONTRACT NO.	DATE
1	11-487	11-487
2	31-97	31-97
3	31-97	31-97
4	52-70	52-70
5	52-70	52-70
6	52-70	52-70
7	52-70	52-70
8	52-70	52-70
9	52-70	52-70
10	52-70	52-70
11	52-70	52-70
12	52-70	52-70
13	52-70	52-70
14	52-70	52-70
15	52-70	52-70
16	52-70	52-70
17	52-70	52-70
18	52-70	52-70
19	52-70	52-70
20	52-70	52-70

T-TIES  
 O-CURBS  
 P-POSTS  
 DTI-TURNING TEE

TYPICAL VALVE INSTALLATION

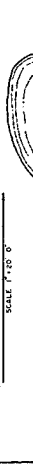


650-06-57 VALVE-IN-Road Electric NPIPE SPRINKLERS



DEPARTMENT OF THE NAVY - NAVAL FAC. CONSTRUCTION CENTER	
NAVAL CONSTRUCTION BATTALION CENTER	
GULFPORT, MISS. 39505	
CSC GOLF COURSE	
SPRINKLER SYSTEM	
ASBUILT - OCT. 1974	
DATE	10001
DESIGNED BY	P.V. DAVIS
CHECKED BY	
APPROVED	
SCALE	AS SHOWN
SHEET	1 OF 1

**WET WELL SYSTEM**  
SCALE 1/8" = 1'-0"

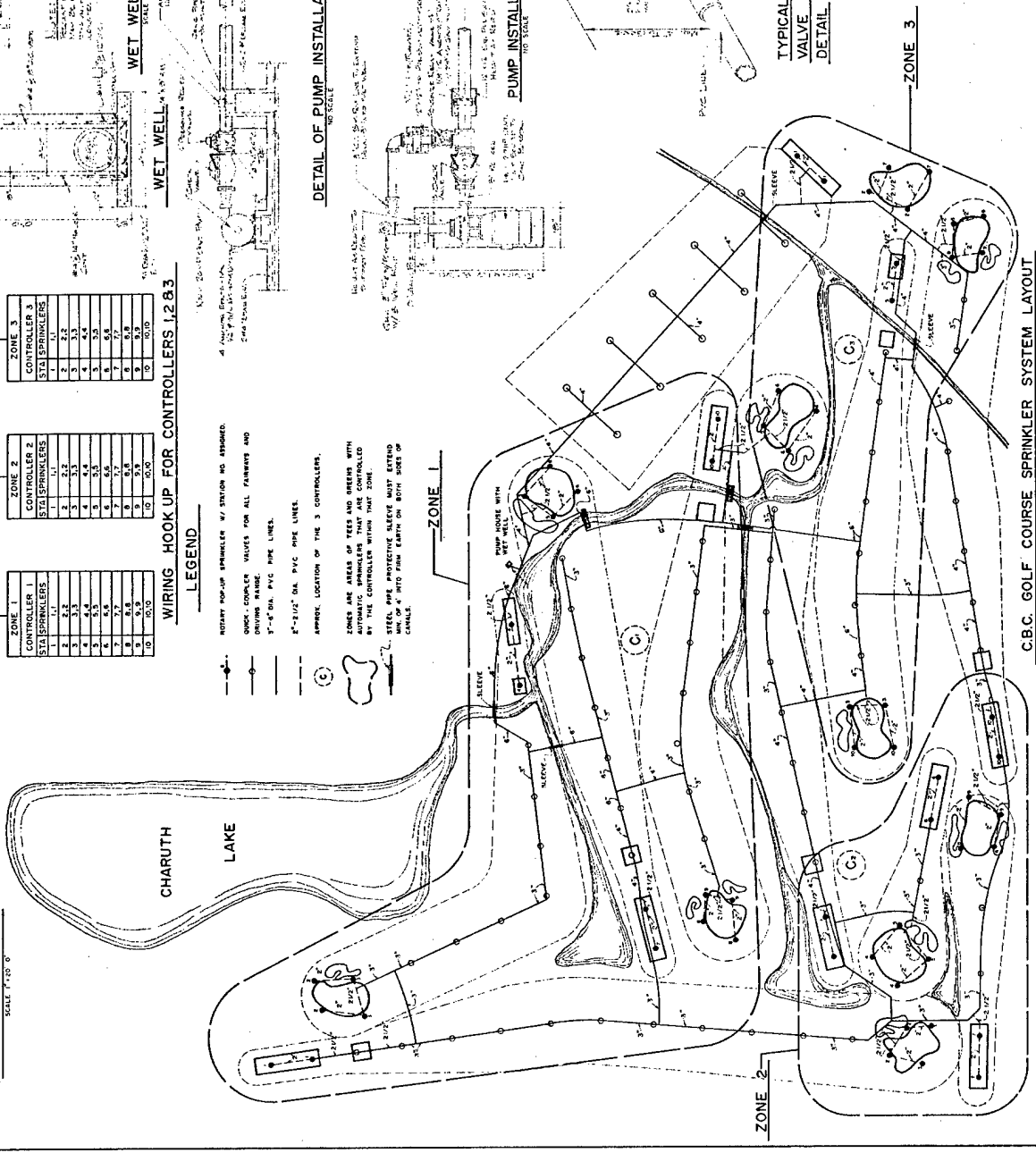


**WIRING HOOK UP FOR CONTROLLERS 1, 2 & 3**

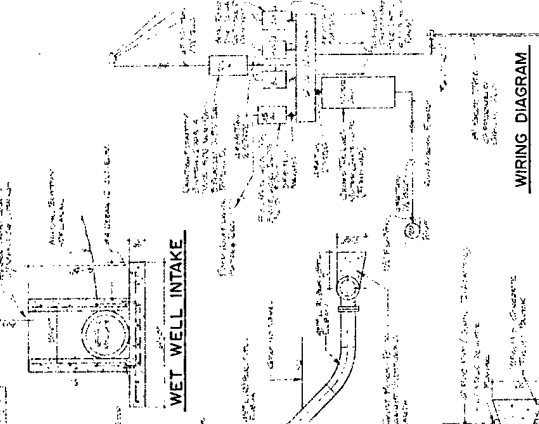
POWER PANEL	ZONE 1	ZONE 2	ZONE 3
SW	1-1	1-1	1-1
SW	2-1	2-1	2-1
SW	3-1	3-1	3-1
SW	4-1	4-1	4-1
SW	5-1	5-1	5-1
SW	6-1	6-1	6-1
SW	7-1	7-1	7-1
SW	8-1	8-1	8-1
SW	9-1	9-1	9-1
SW	10-1	10-1	10-1

**LEGEND**

- ROTARY POP-UP SPRINKLER W/ STATION NO ASSIGNED
- QUICK-COUPLER VALVES FOR ALL FAIRWAYS AND DRIVING RANGE
- 1/2" DIA. PVC PIPE LINES
- 2" DIA. PVC PIPE LINES
- APPROX. LOCATION OF THE 3 CONTROLLERS.
- ZONE ARE AREAS OF THE GOLF COURSE WHICH ARE CONTROLLED BY THE CONTROLLER WITHIN THAT ZONE.
- STEEL PIPE PROTECTIVE BLEEDER MUST EXTEND MIN. OF 4" INTO FAIRWAY ON BOTH SIDES OF CHANNEL.



**C.B.C. GOLF COURSE SPRINKLER SYSTEM LAYOUT**  
SCALE 1/8" = 1'-0"



**WIRING DIAGRAM**

**WET WELL INTAKE**

**WET WELL DETAILS**

**WET WELL**

**DETAIL OF PUMP INSTALLATION**

**PUMP INSTALLATION PLAN**

**TYPICAL QUICK-COUPLER VALVE INSTALLATION DETAIL**

**TYPICAL ROTARY POP-UP SPRINKLER INSTALLATION DETAIL**

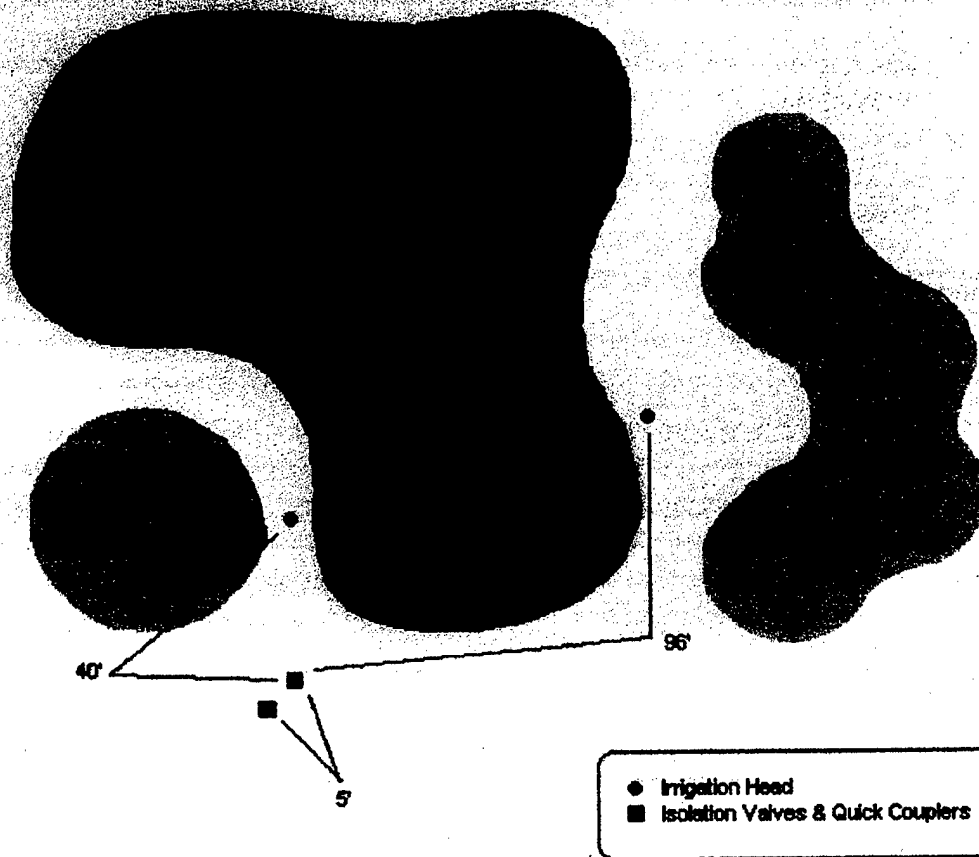
DEPARTMENT OF THE NAVY - NAVAL FAC ENGINEERING CENTER  
NAVAL CONSTRUCTION BATTALION CENTER  
GULFWATER, MISSISSIPPI

**C.B.C. GOLF COURSE SPRINKLER SYSTEM**

DATE: 11/11/54  
BY: [Signature]  
CHECKED: [Signature]  
SCALE: AS SHOWN  
SHEET: 1 OF 2

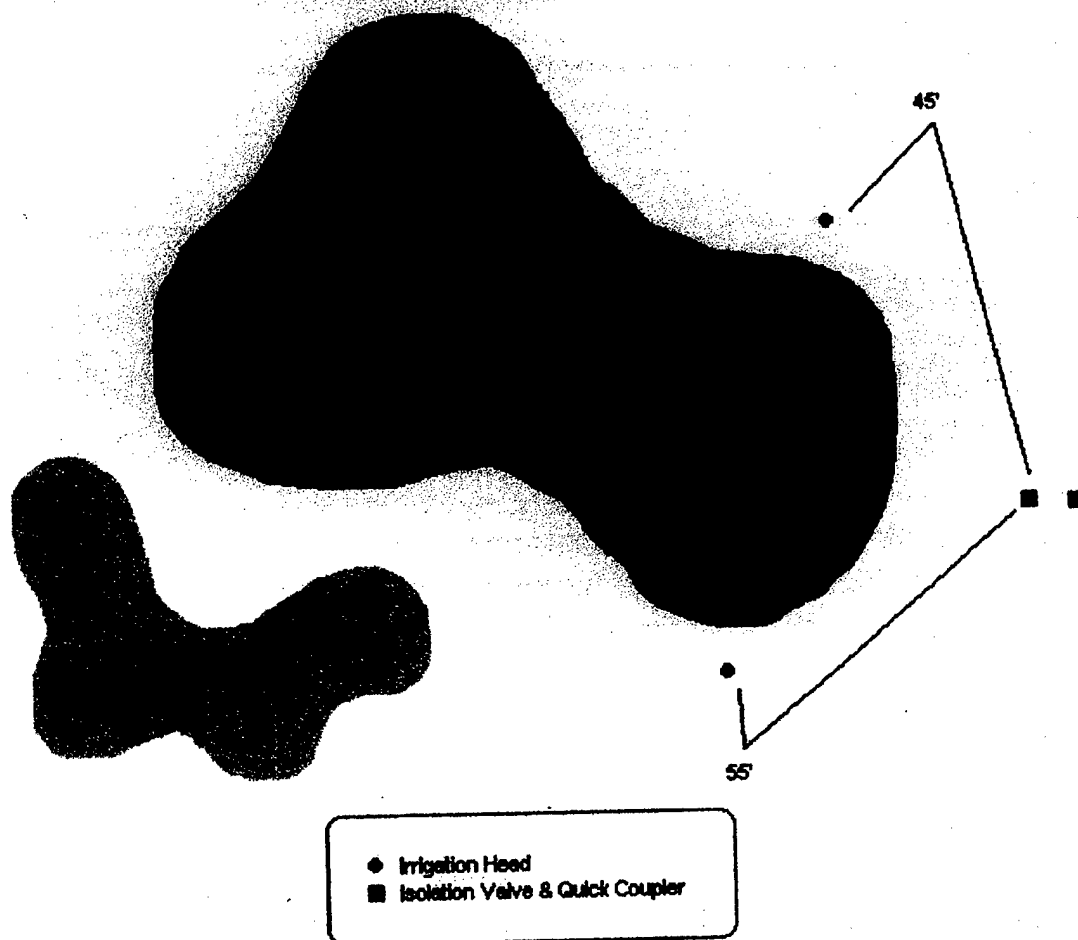
***APPENDIX IV - IRRIGATION SYSTEM***  
***FOR THE BACK NINE HOLES AT PINE***  
***BAYOU GOLF COURSE, NCBC***  
***GULFPORT, MS***

NCBC Gulfport, MS  
Pine Bayou GC 1998  
#1 Green-Irrigation Valves



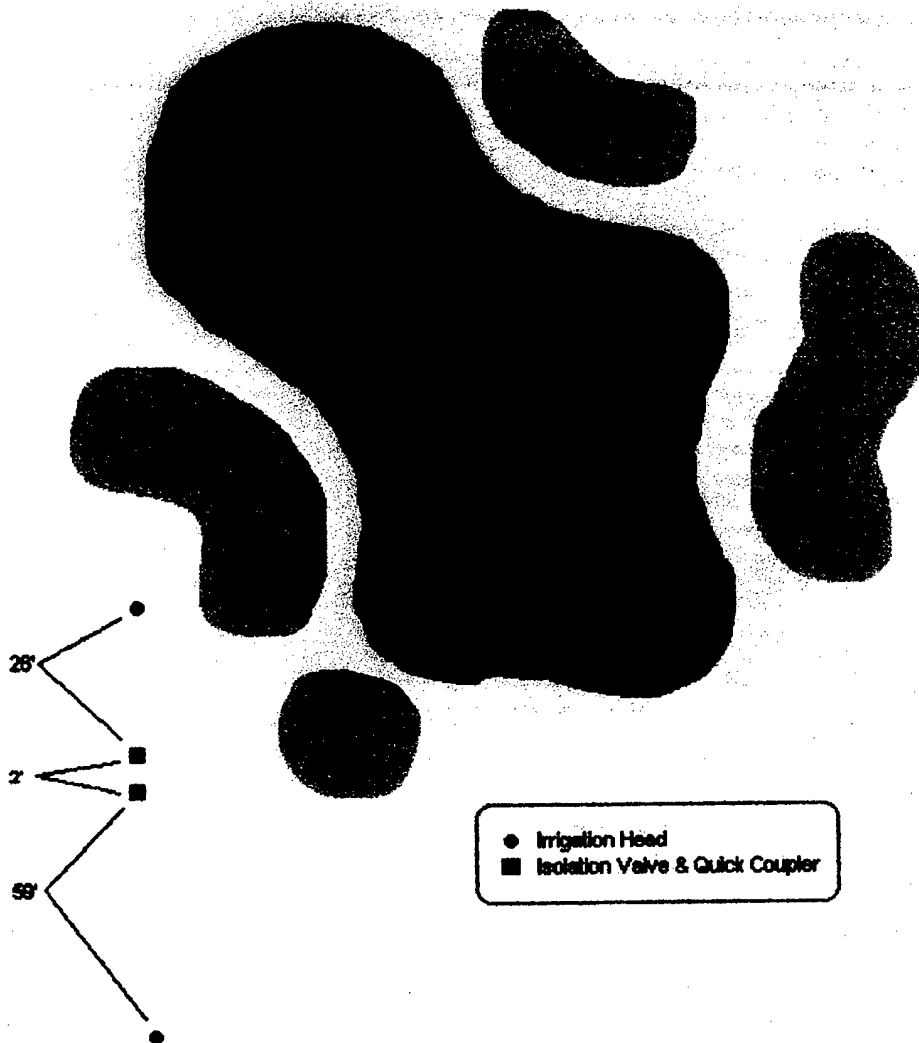
Tifton Golf Services - Tifton, GA \*\*As-Builts Not To Scale\*

NCBC Gulfport, MS  
Pine Bayou GC 1998  
#2 Green-Irrigation Valves



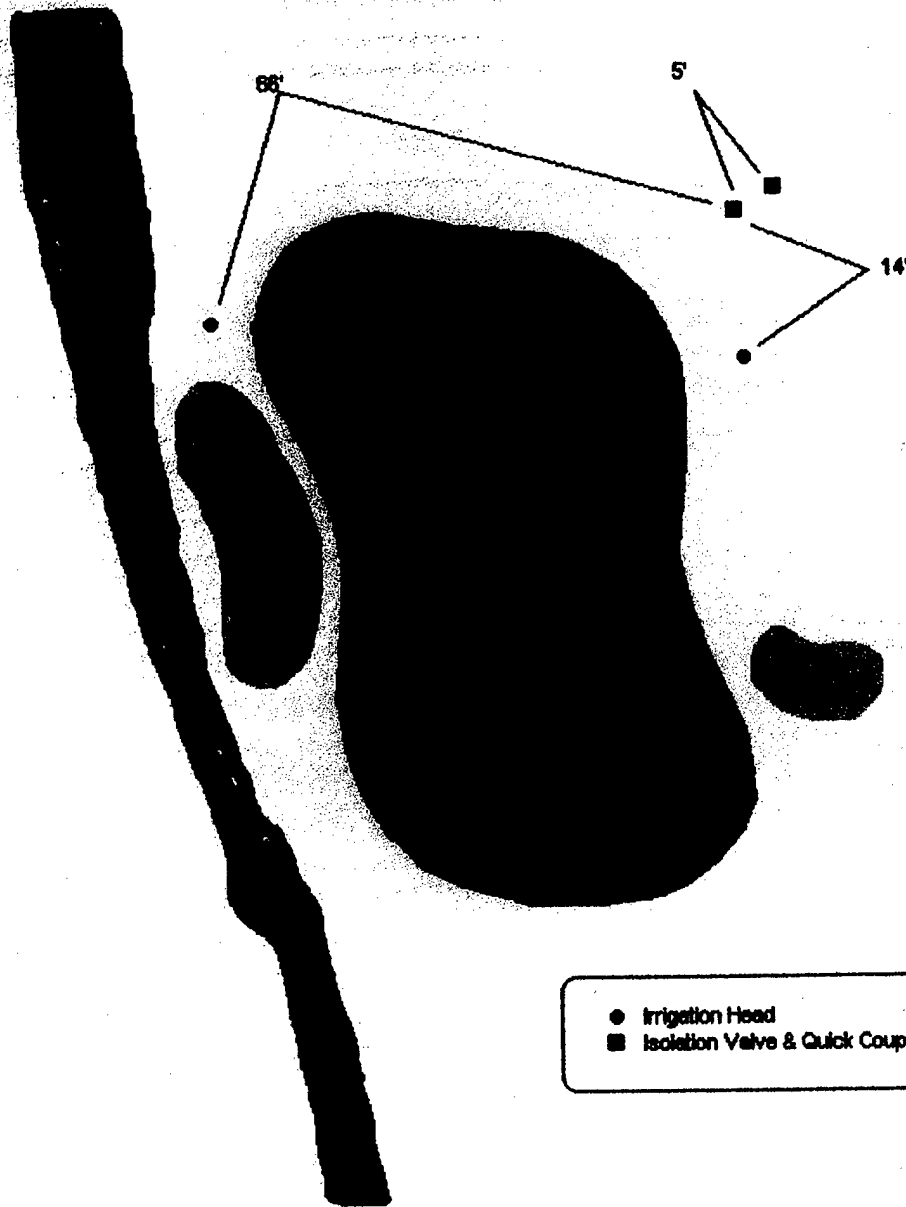
Tifton Golf Services - Tifton, Ga. \*\*As-Builts Not To Scale\*\*

NCBC Gulfport, MS  
Pine Bayou GC 1998  
#3 Green-Irrigation Valves



Tifton Golf Services - Tifton, Ga. \*\*As-Builts Not To Scale\*\*

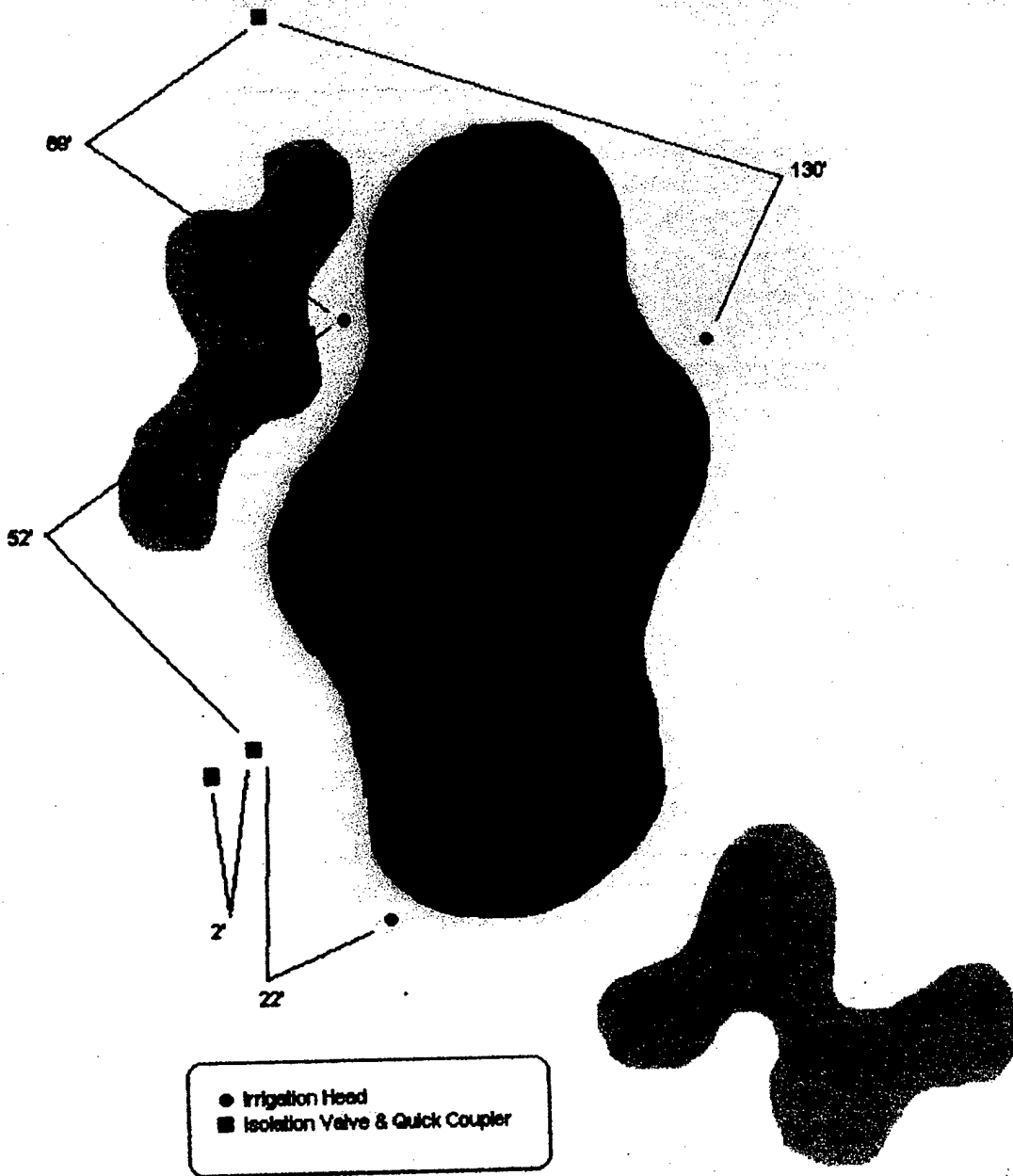
NCBC Gulfport, MS  
Pine Bayou GC 1998  
#4 Green-Irrigation Valves



● Irrigation Head  
■ Isolation Valve & Quick Coupler

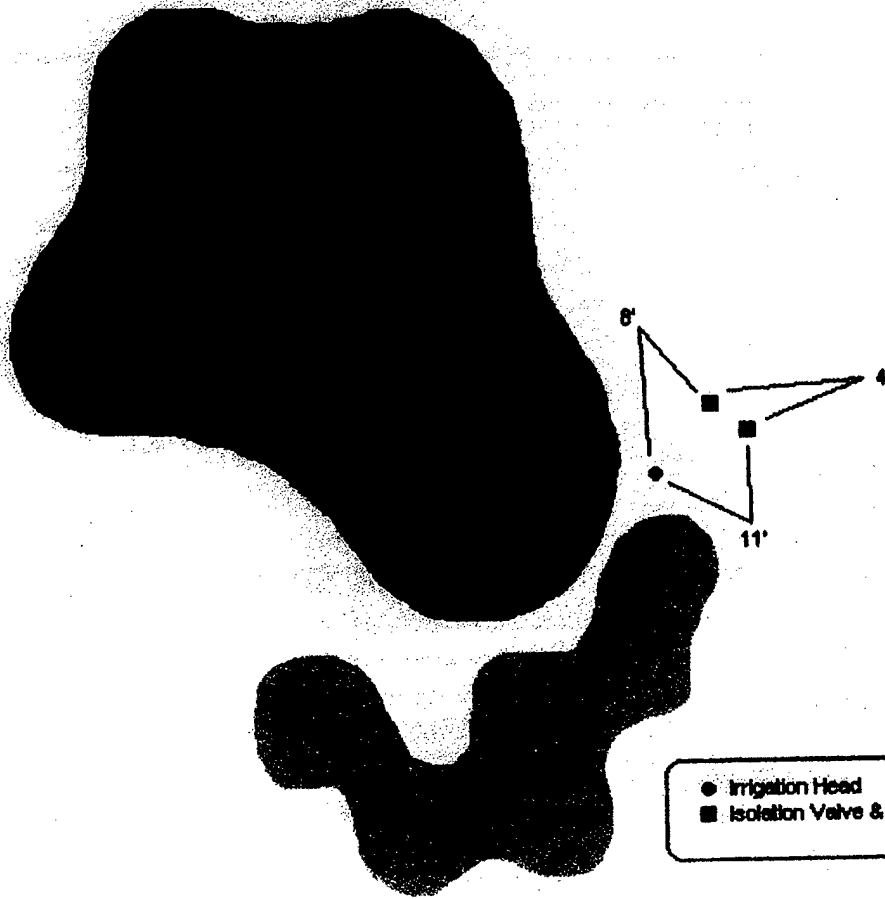
Tifton Golf Services - Tifton, Ga. \*\*As-Builts Not To Scale\*\*

NCBC Gulfport, MS  
Pine Bayou GC 1998  
#5 Green-Irrigation Valves



Tifton Golf Services - Tifton, Ga. \*\*As-Builts Not To Scale\*\*

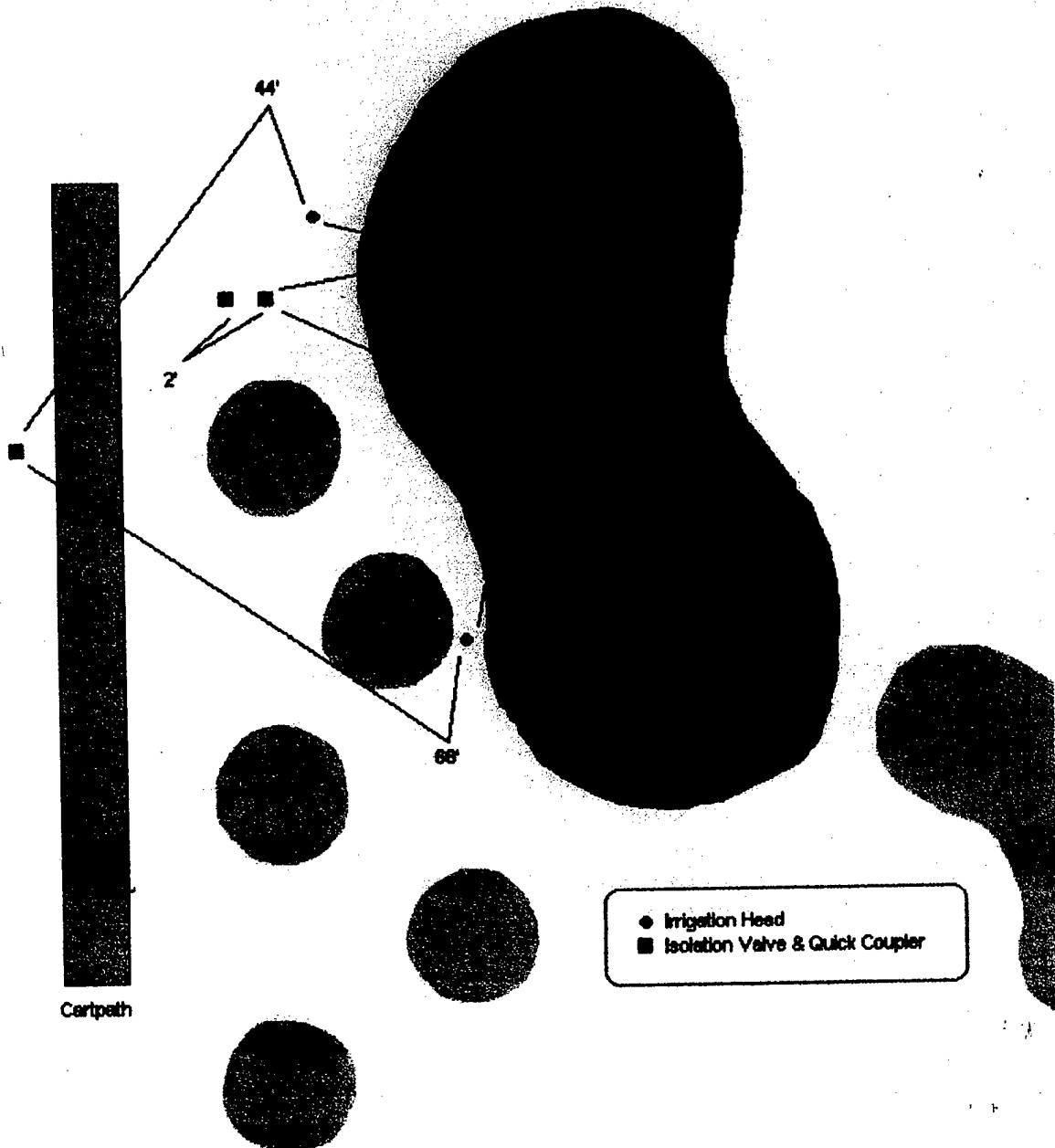
NCBC Gulfport, MS  
Pine Bayou GC 1998  
#6 Green-Irrigation Valves



● Irrigation Head  
■ Isolation Valve & Quick Coupler

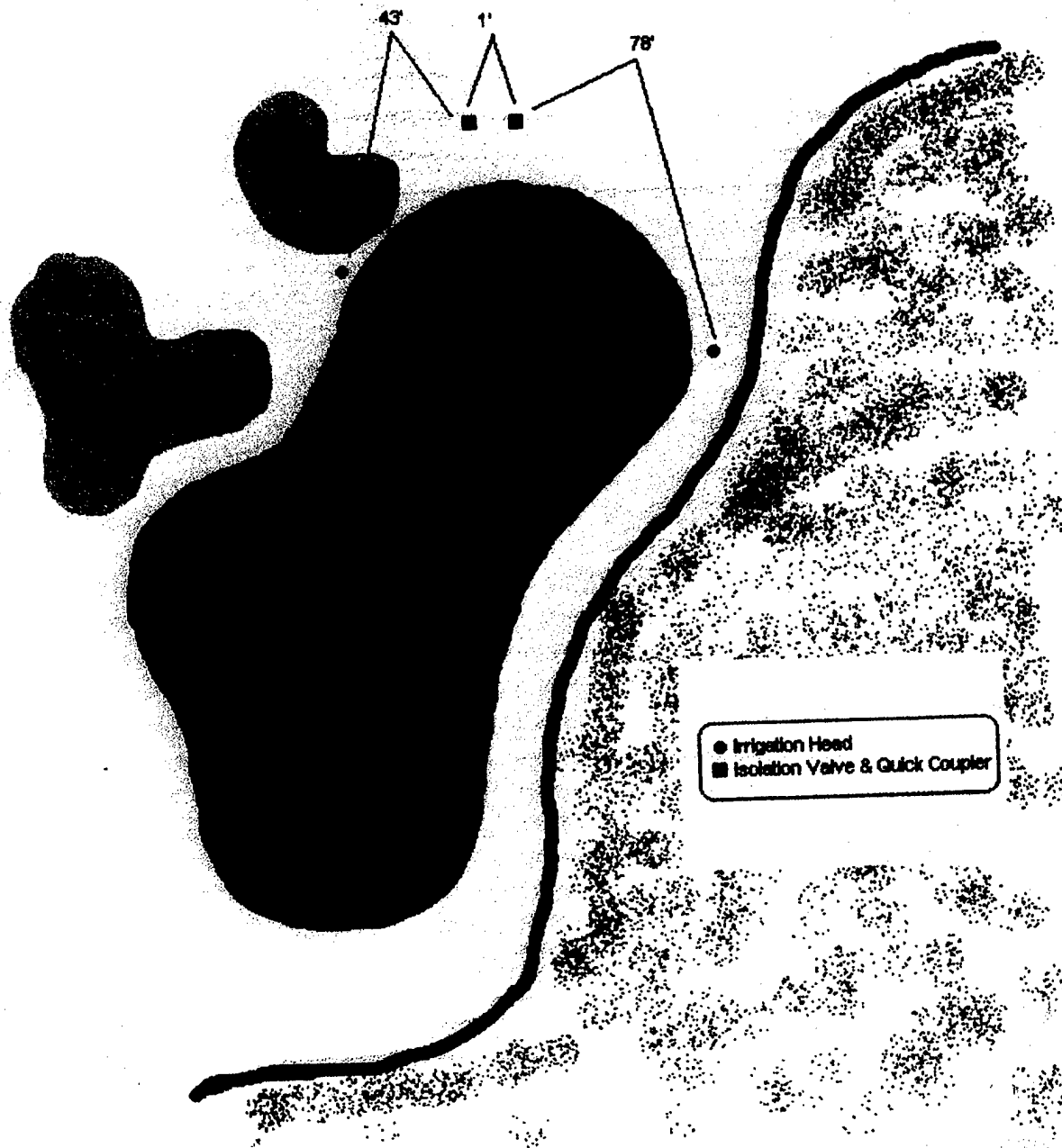
Tifton Golf Services - Tifton, Ga. \*\*As-Builts Not To Scale\*\*

NCBC Gulfport, MS  
Pine Bayou GC 1998  
#7 Green-Irrigation Valves



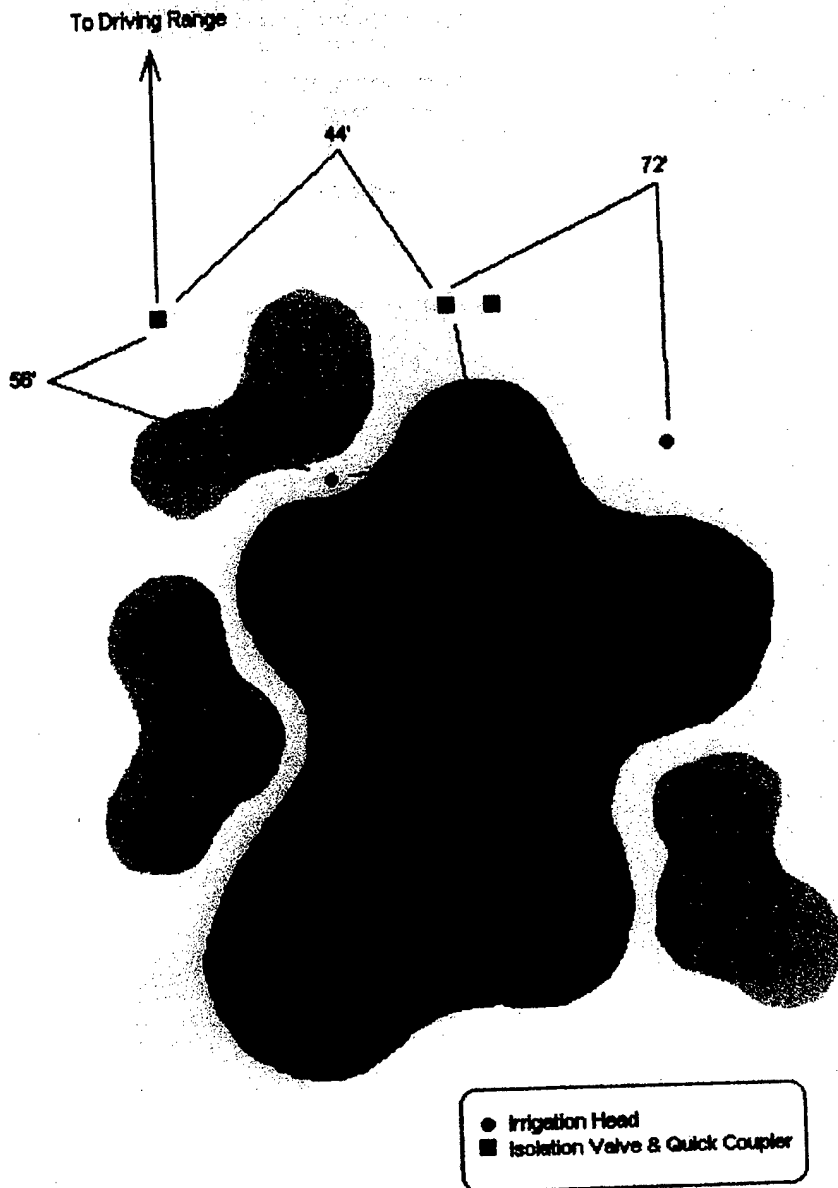
Tifton Golf Services - Tifton, Ga \*\*As-Builts Not To Scale\*\*

NCBC Gulfport, MS  
Pine Bayou GC 1998  
#8 Green-Irrigation Valves



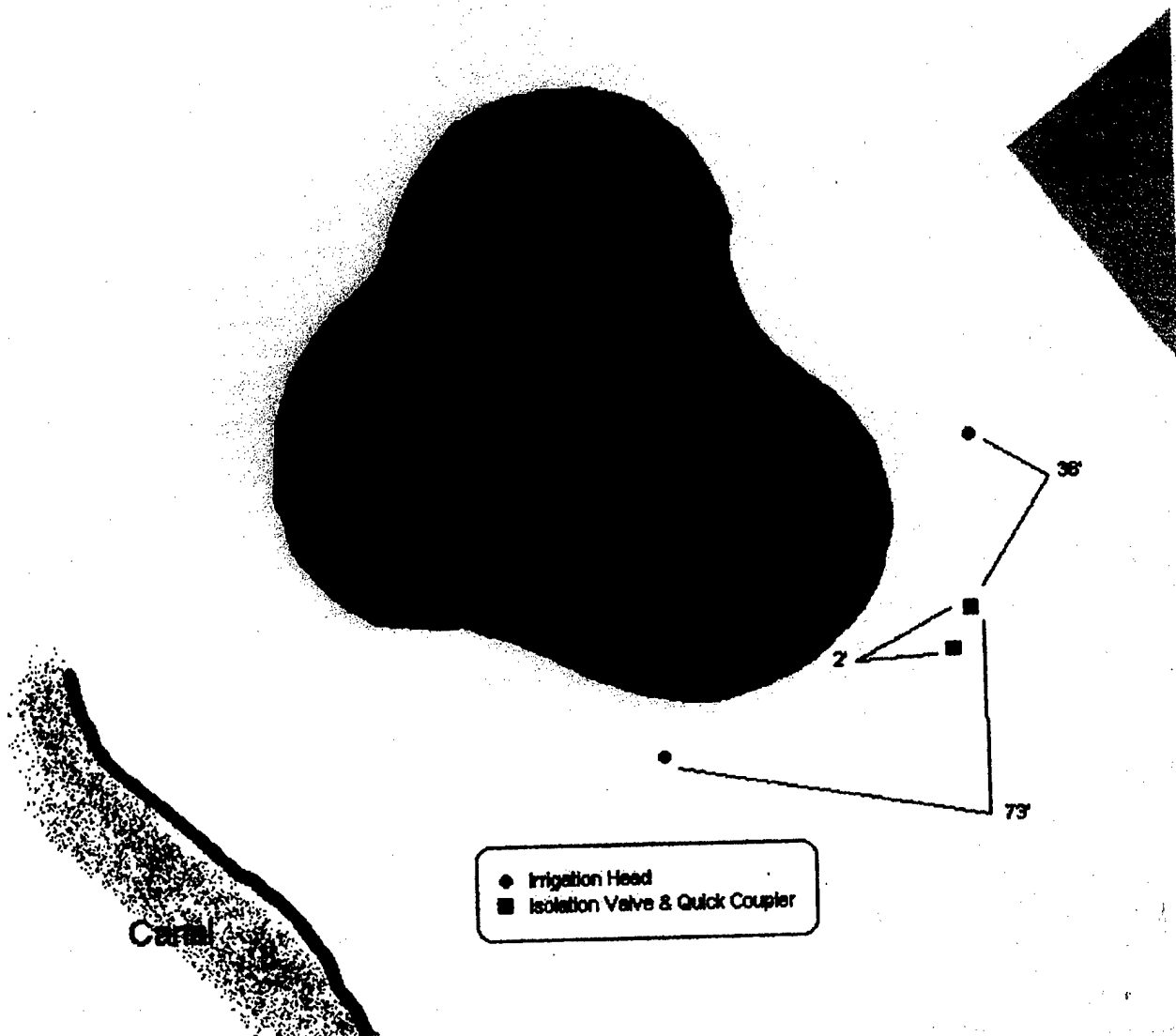
Tifton Golf Services - Tifton, Ga \*\*As-Builts Not To Scale\*\*

NCBC Gulfport, MS  
Pine Bayou GC 1998  
#9 Green-Irrigation Valves



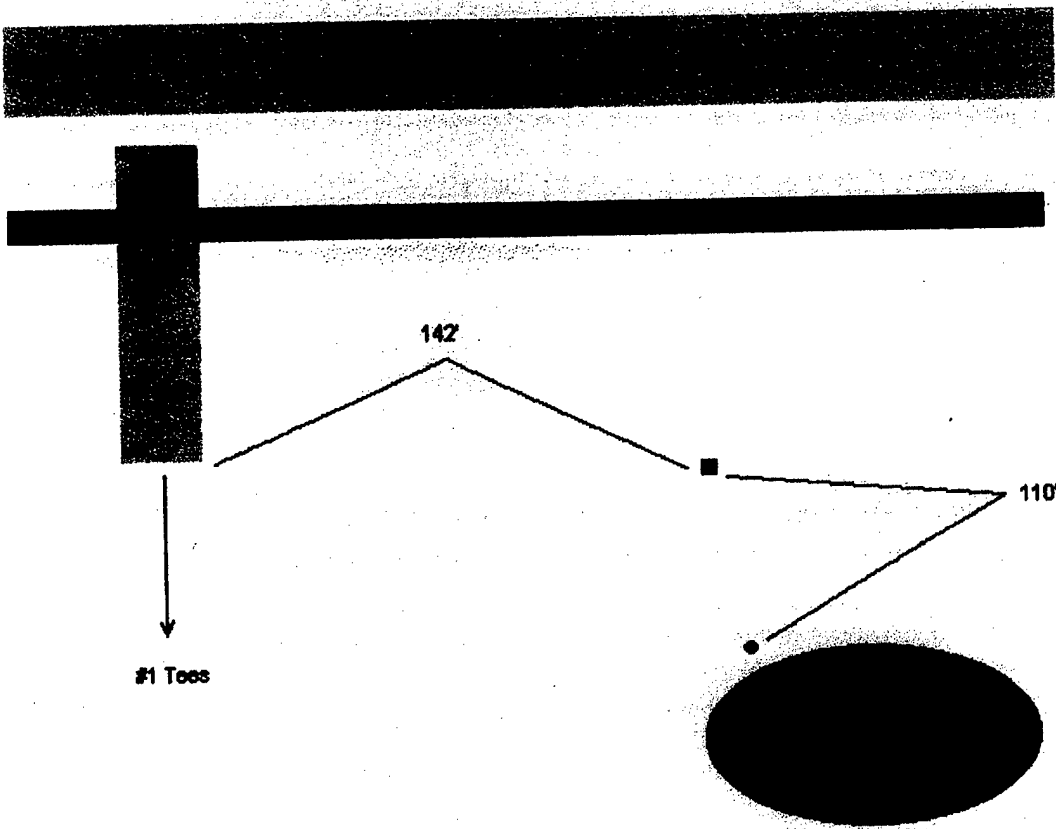
Tifton Golf Services - Tifton, Ga \*\*As-Builts Not To Scale\*\*

NCBC Gulfport, MS  
Pine Bayou GC 1998  
PPG-Irrigation Valves



Tifton Golf Services - Tifton Ga \*\*As-Builts Not To Scale\*\*

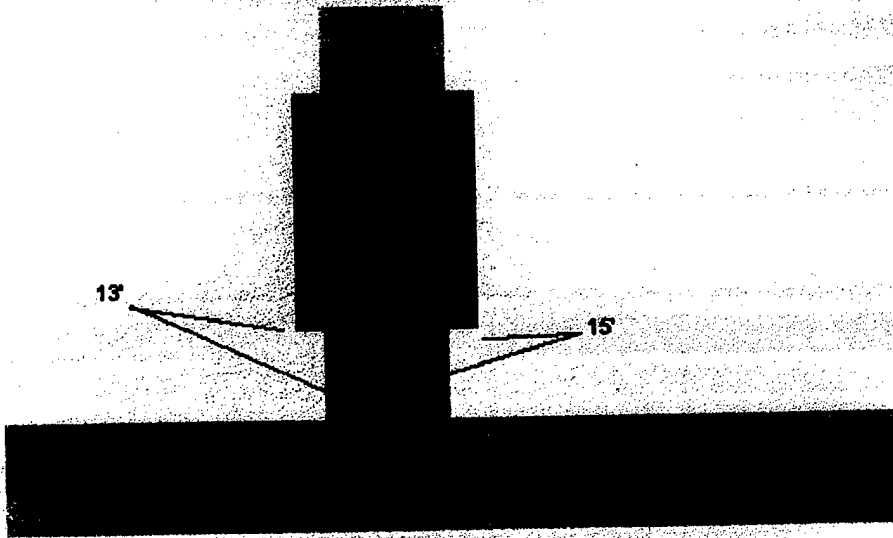
NCBC Gulfport, MS  
Pine Bayou GC 1998  
Irrigation - Main Line Valve



Tifton Golf Services - Tifton, Ga \*As-Builts Not To Scale\*

NCBC Gulfport, MS  
Pine Bayou GC. 1998  
Irrigation - Main Line Valve

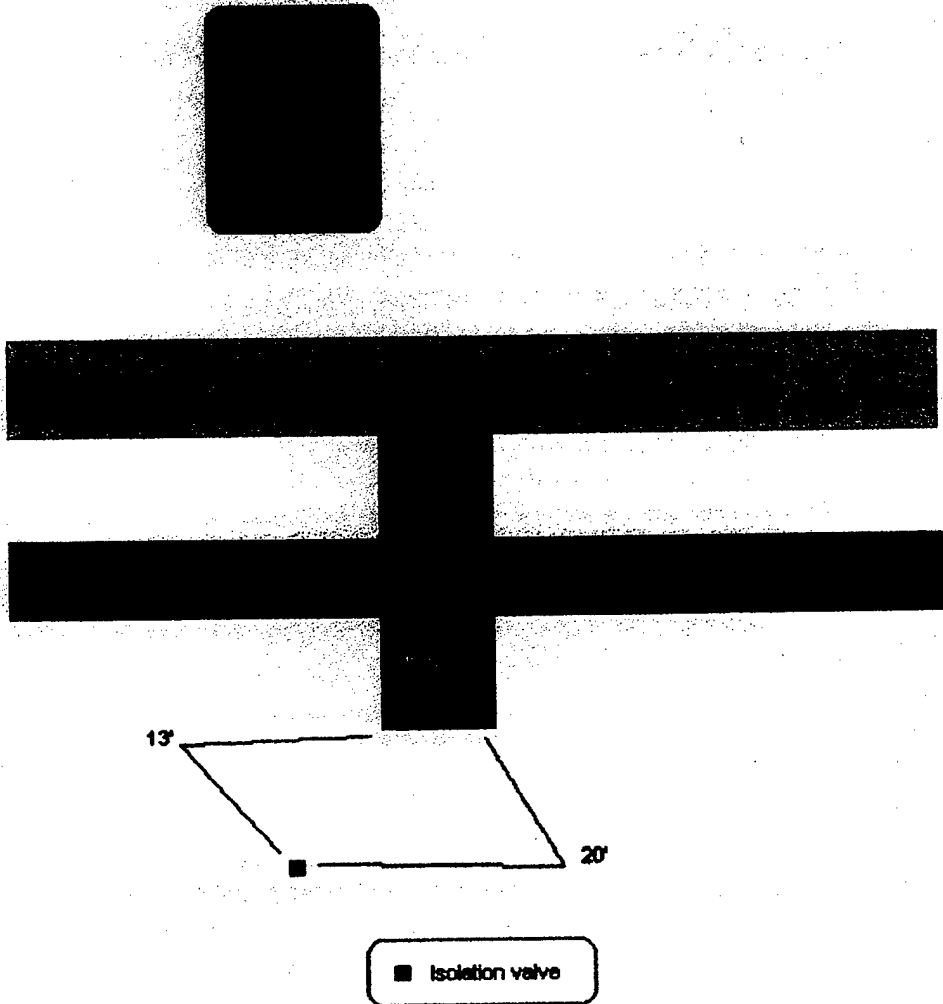
To #1 Green & #2 Tees



■ Isolation valve for everything on east side of bridge

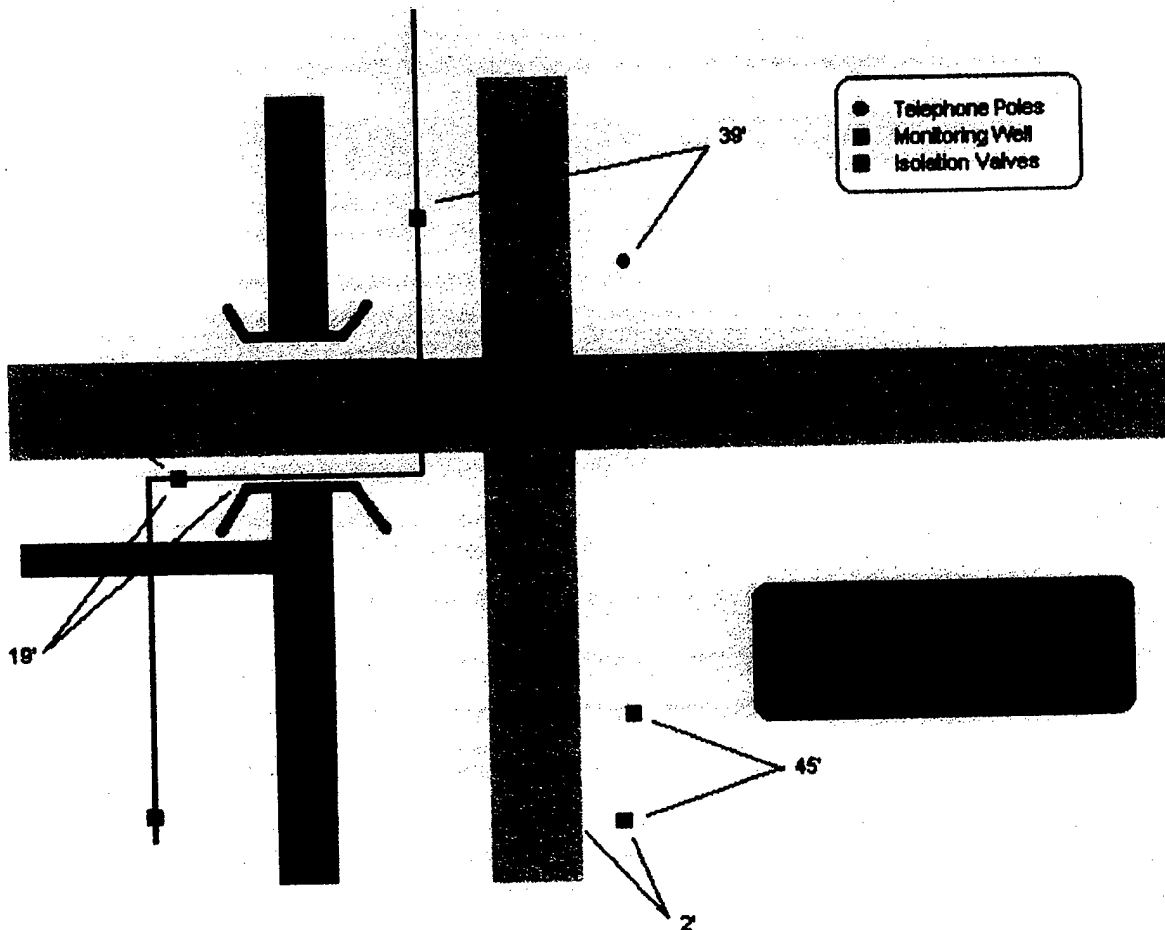
Tifton Golf Services - Tifton, Ga \*As-Builts Not To Scale\*

NCBC Gulfport, MS  
Pine Bayou GC 1998  
#2 Bridge-Irrigation Valve



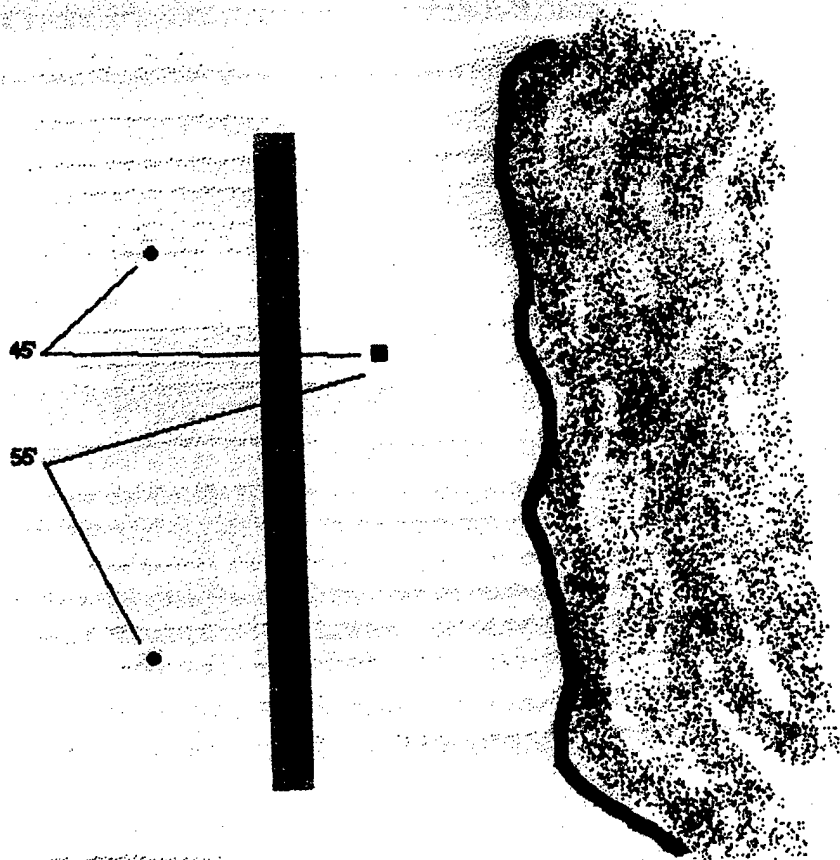
Tifton Golf Services - Tifton, Ga \*\*As-Builts Not To Scale\*\*

NCBC Gulfport, MS  
Pine Bayou GC 1998  
Roadway-Irrigation Valves



Tifton Golf Services - Tifton, Ga \*\*As-Builts Not To Scale\*\*

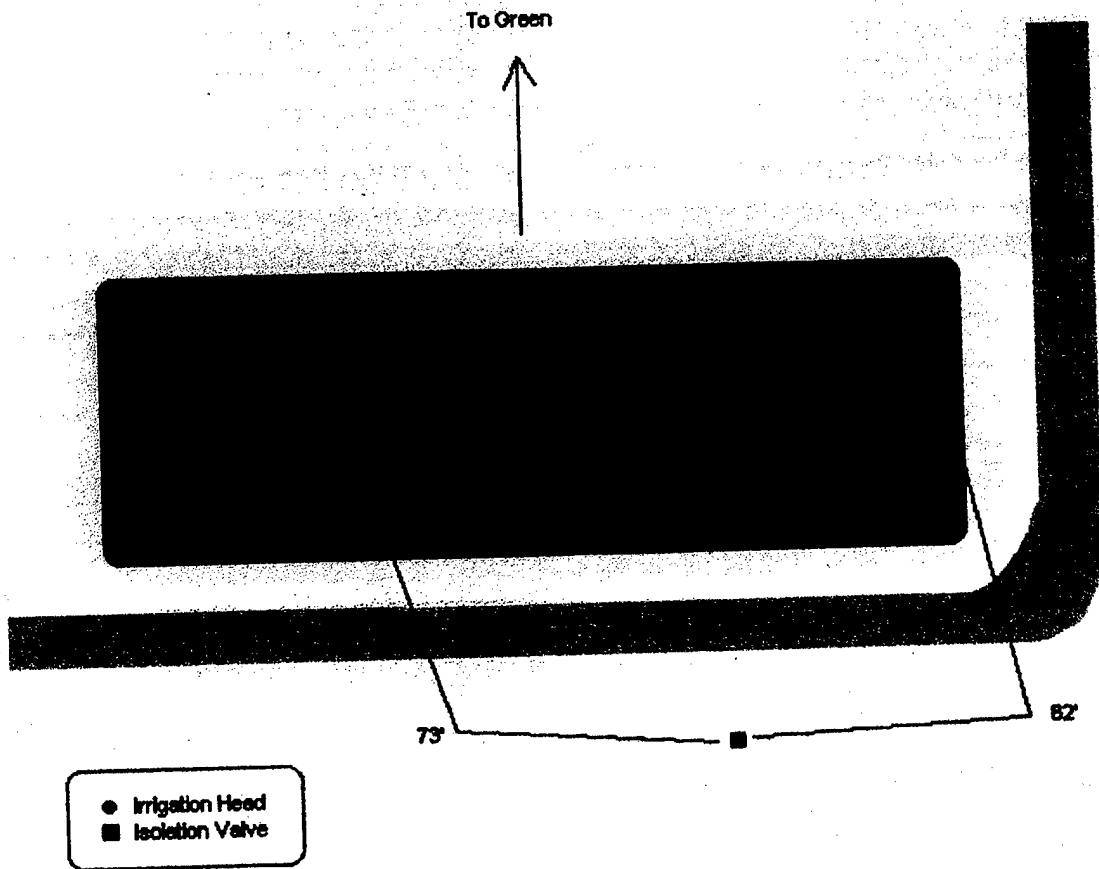
NCBC Gulfport, MS  
Pine Bayou GC 1998  
#3 Lake Fill-Irrigation Valve



- Irrigation Head
- Irrigation Controller
- Lake Fill Valve

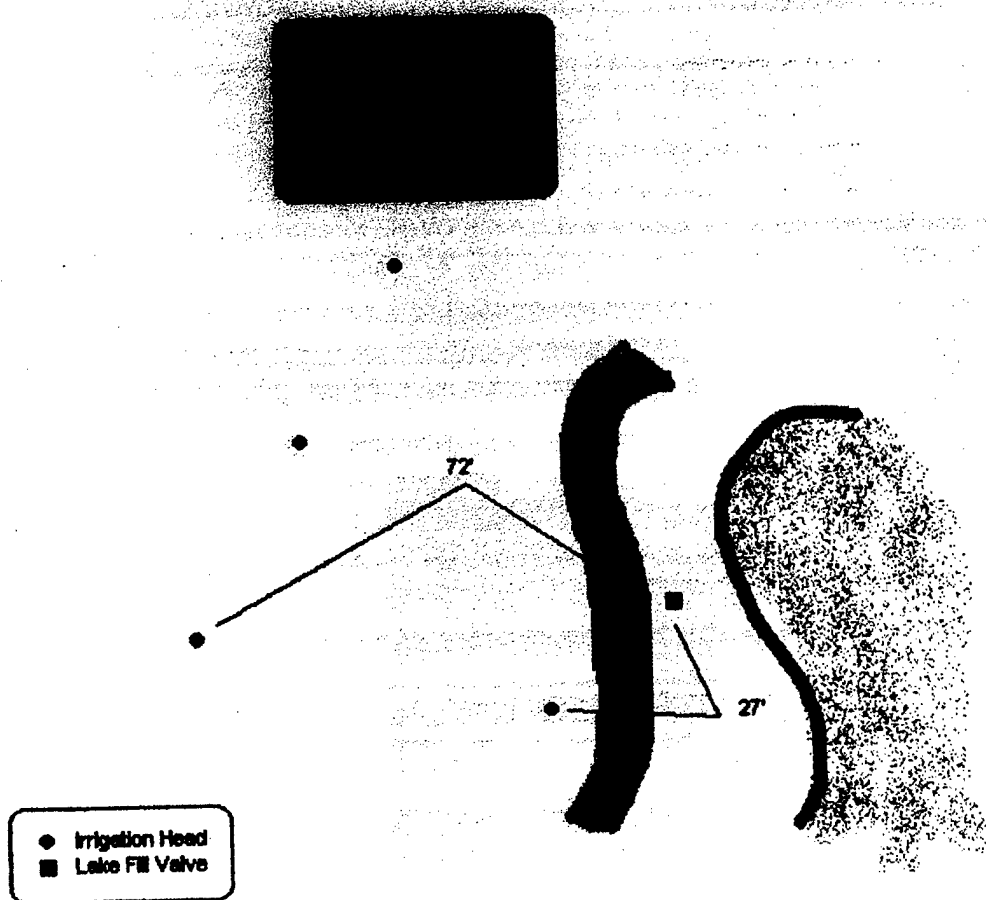
Tifton Golf Services - Tifton, Ga \*\*As-Builts Not To Scale\*\*

NCBC Gulfport, MS  
Pine Bayou GC 1998  
#4 Tee-Irrigation Valves



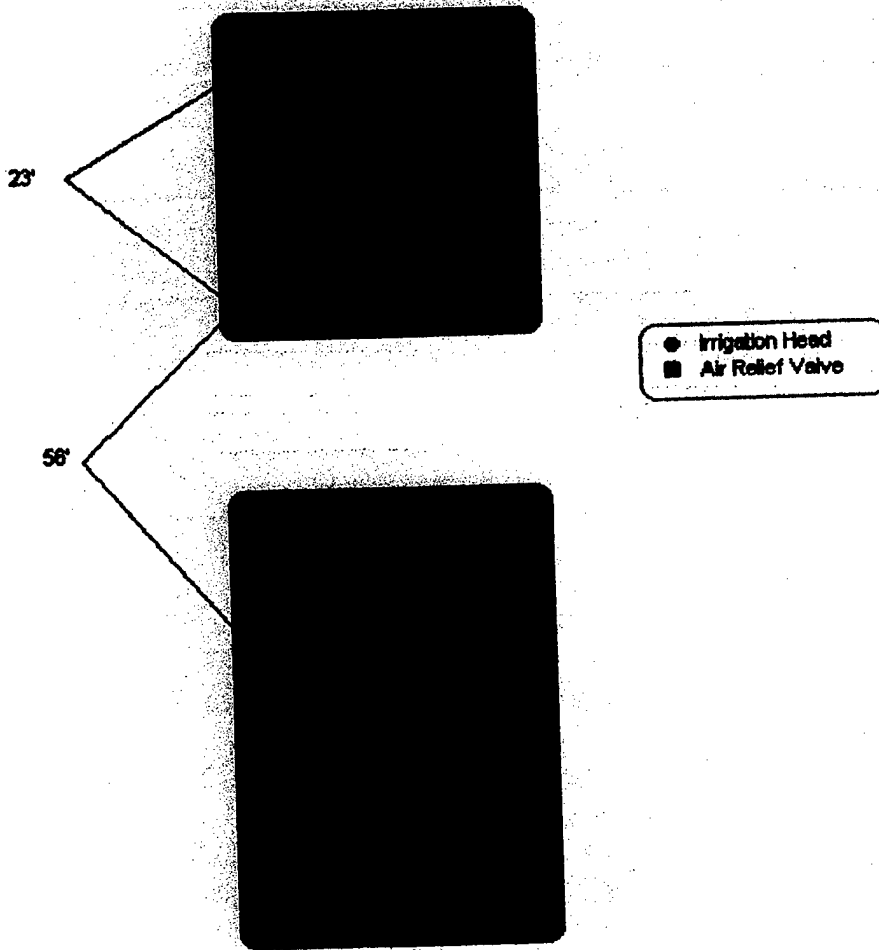
Tifton Golf Services - Tifton, Ga \*\*As-Builts Not To Scale\*\*

NCBC Gulfport, MS  
Pine Bayou GC 1998  
#5 Lake Fill-Irrigation Valve



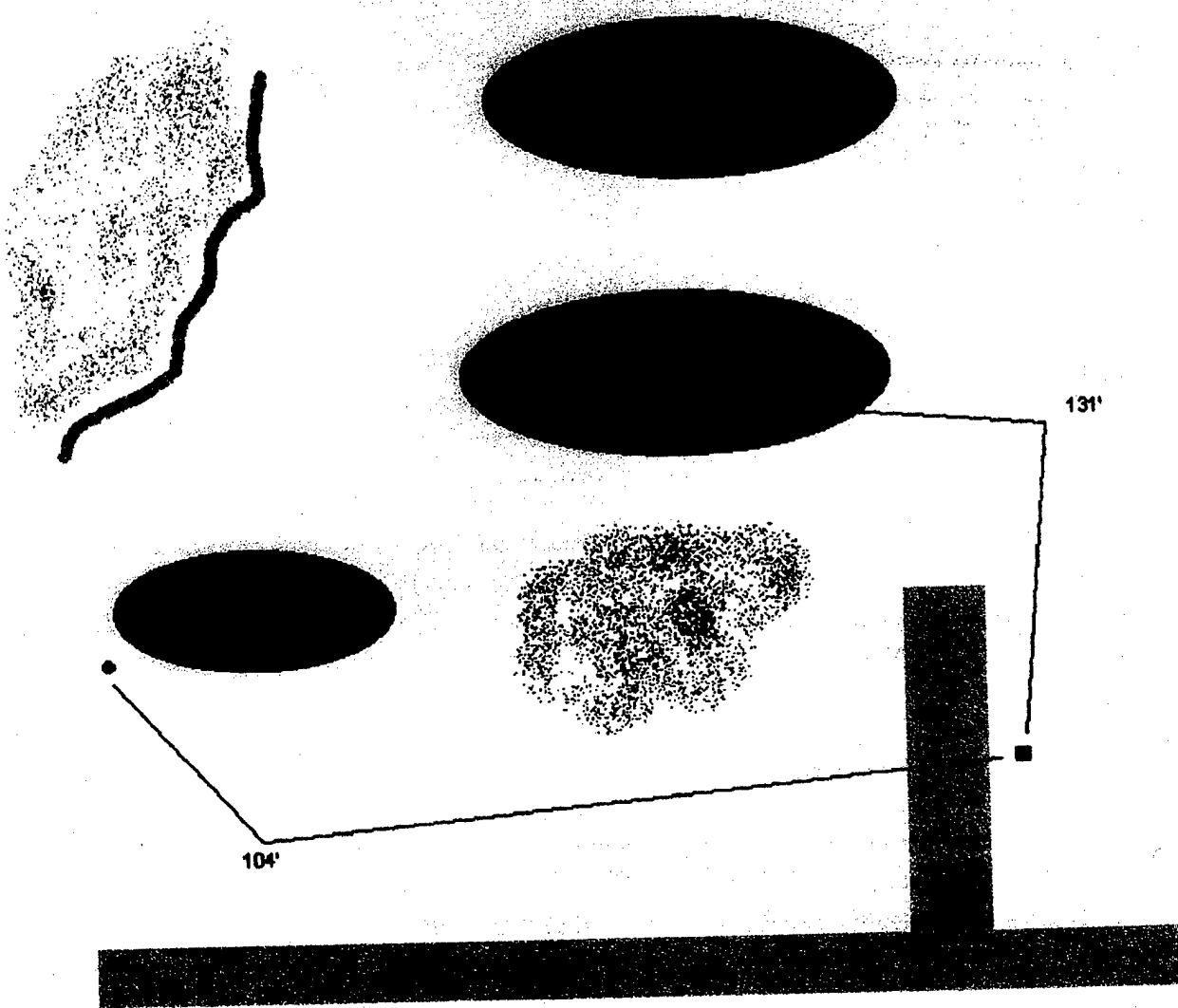
Tifton Golf Services - Tifton, Ga \*\*As-Builts Not To Scale\*\*

NCBC Gulfport, MS  
Pine Bayou GC 1998  
#7 Tee-Air Relief Valve



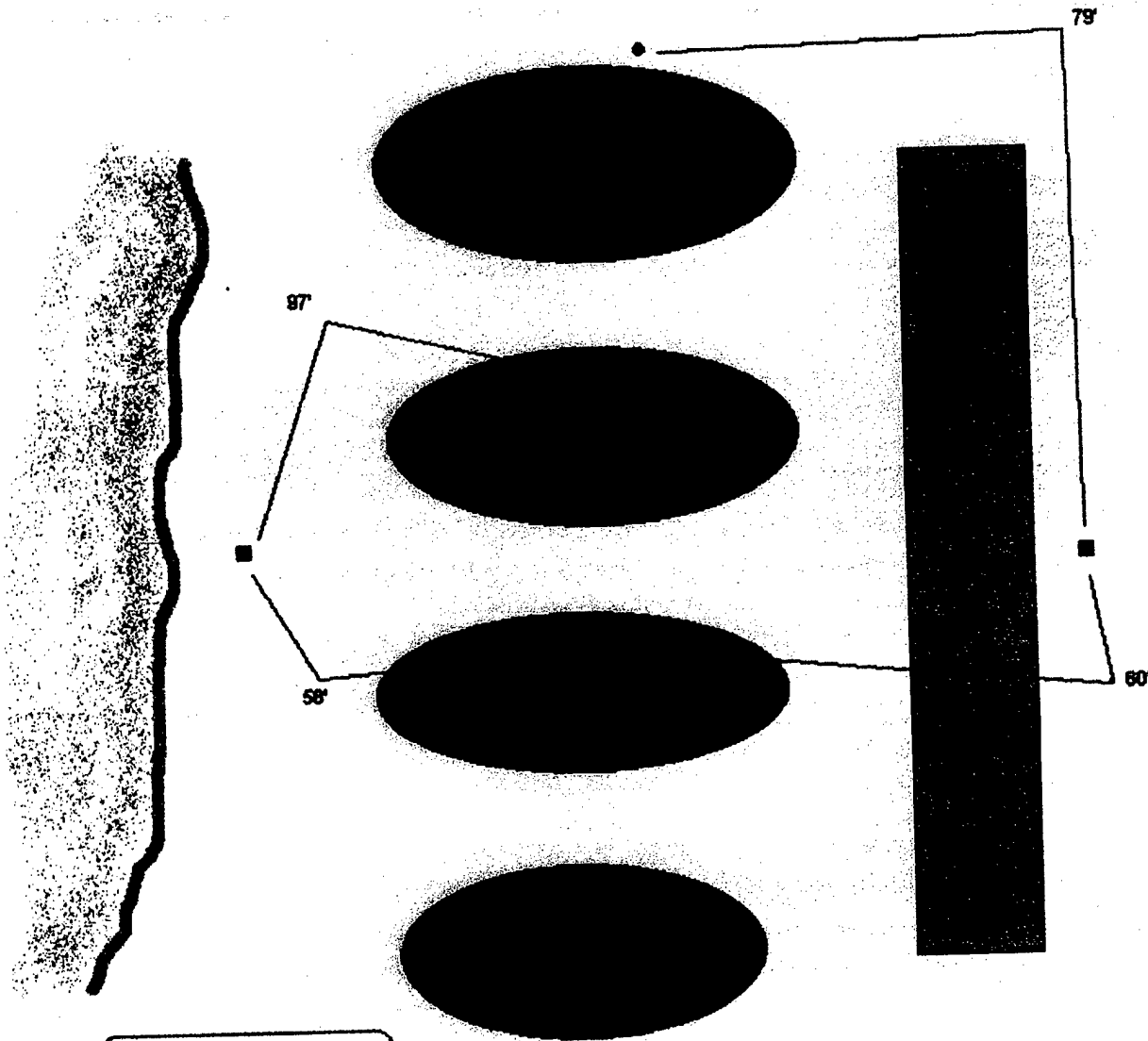
Tifton Golf Services - Tifton, Ga \*\*As-Builts Not To Scale\*\*

NCBC Gulfport, MS  
Pine Bayou GC 1998  
#8 Tee-Main Line Irrigation Valve



Tifton Golf Services - Tifton, Ga \*\*As-Builts Not To Scale\*\*

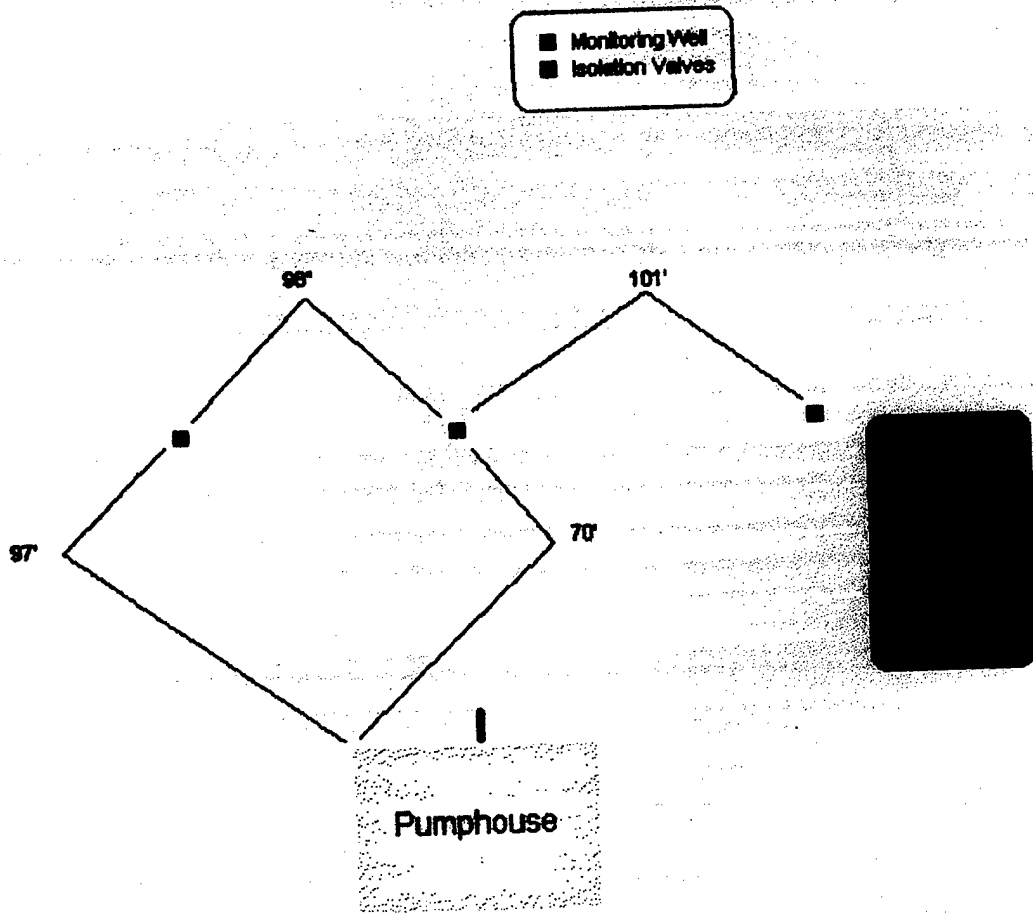
NCBC Gulfport, MS  
Pine Bayou GC 1998  
#8 Tee-Lake Fill Valve



- Irrigation Head
- Isolation Valves & Lake Fill

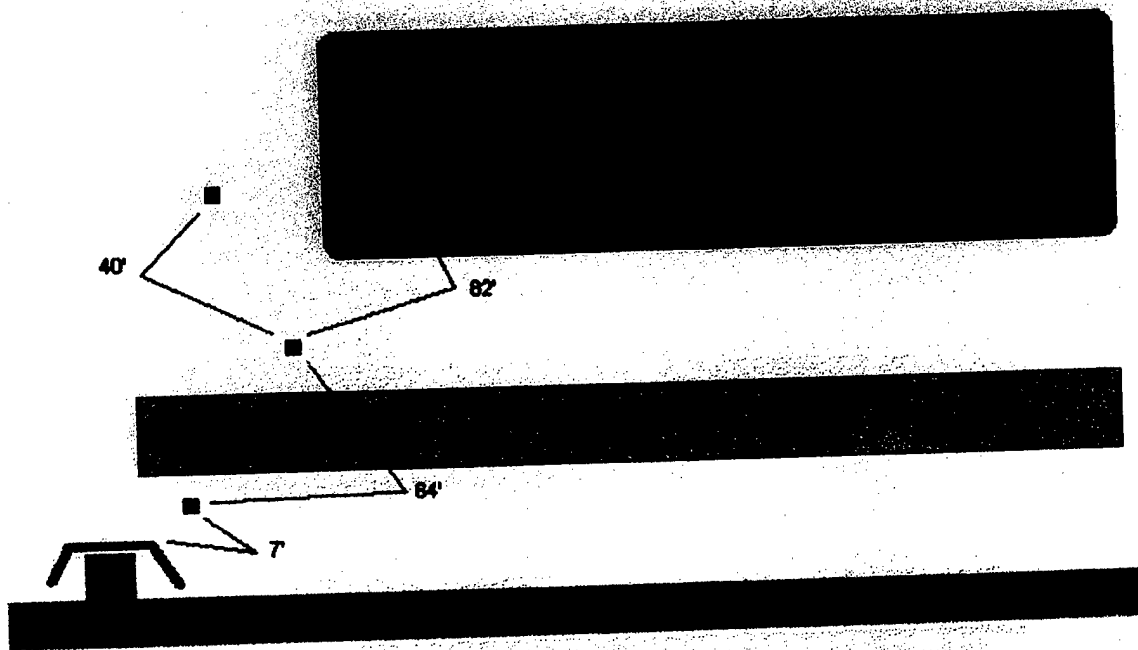
Tifton Golf Services - Tifton, Ga \*\*As-Builts Not To Scale\*\*

NCBC Gulfport, MS  
Pine Bayou GC 1998  
Pumphouse-Irrigation Main Line Valves



Tifton Golf Services - Tifton, Ga \*\*As-Builts Not To Scale\*\*

NCBC Gulfport, MS  
Pine Bayou GC 1998  
Driving Range-Irrigation Valves



- Irrigation Head
- Irrigation Controller
- Isolation valve

Tifton Golf Services - Tifton, Ga \*\*As-Builts Not To Scale\*\*

## ***APPENDIX V - REFERENCES***

## REFERENCES

1. Aston, R. L., 2003. Environmental Law for Engineers and Geoscientists. Lewis Publishers, Inc., Boca Raton, FL.
2. CH2M Hill, 2003. MT-WRF Upgrade and NAS PAX Water Reuse System Conceptual Design Summary. Herndon, VA.
3. CH2M Hill, 2003. NAS PAX Reuse Project Definition Workshop. Herndon, VA.
4. Della-Volle, J., 2003. NCBC Gulfport Wastewater Numbers. Naval Construction Battalion Center, Gulfport, MS.
5. Eisenberg, N. A., 2003. Environmental Risk Analysis: Lecture Notes. University of Maryland, College Park, MD.
6. Environmental Technology Centre, 2003. The Environmental Guide to Pollution Control Technology: Rotating Biological Contactor. <http://www.nottingham.ac.uk/~enzetc/guide/engsol/P76.HTM>.
7. Florida Department of Environmental Protection, 2003. Sample Advisory Signs. <http://www.dep.state.fl.us/water/reuse/notifica.htm>.
8. Gatian, N., 2003. Phone Interview. Mississippi Department of Environmental Quality. Biloxi, MS.
9. Harrison County Development Commission, 2003. Gulf Coast Major Employers. <http://www.mscoast.org>. Gulfport, MS.
10. Hao, O. J., 2003. Theory of Aqueous and Solid Waste Treatment and Disposal: Lecture Notes. University of Maryland, College Park, MD.
11. Metcalf and Eddy, Inc., 2003. Wastewater Engineering: Treatment and Reuse, Fourth Edition. McGraw Hill, Inc., New York, NY.
12. National Climatic Data Center, 2003. Mississippi Climate Summary, July 2003. <http://lwf.ncdc.noaa.gov/oa/climate/research/cag3/MS.html>. Asheville, NC.
13. Naval Facilities Engineering Service Center, 2003. Navy Water Conservation Ashore Website. <http://navyenergy.nfesc.navy.mil/management/WaterWeb.html>.
14. Norton, B. M., 2003. NCBC Gulfport DUERS Database. Gulfport, MS.
15. Pine Bayou Golf Course, 2003. Official Scorecard. Gulfport, MS.

16. White, M. C., 2003. Environmental Law for Scientists and Engineers: Lecture Notes. University of Maryland, College Park, MD.
17. CH2M Hill, 2002. Naval Air Station Pautuxent River Water Reuse Feasibility Study: Draft Report. Herndon, VA.
18. Davis, A. P., 2002. Unit Operations of Environmental Engineering: Lecture Notes. University of Maryland, College Park, MD.
19. Malkin, J. B., 2002. Control and Treatment of Heavy Metals in Drinking Water Sources. University of Maryland, College Park, MD.
20. Maryland Department of the Environment, 2002. Guidelines for Land Treatment of Municipal Wastewaters. MDE-WMA-001-07/02.
21. Fjeld, R. A. and Compton, K. L., 1998. Instructional Modules for Risk Assessment and Technology Evaluation. Clemson University, Clemson, SC.
22. Kontos, N. and Asano, T., 1996. Environmental Assessment for Wastewater Reclamation and Reuse Projects. *Water Sci. Tech.* Vol. 33, No. 10-11, pp. 473-486.
23. Green, F. B., Bernstone, L., Lundquist, T. J., Muir, J., Tresan, R. B., and Oswald, W. J., 1995. Methane Fermentation, Submerged Gas Collection, and the Fate of Carbon in Advanced Integrated Wastewater Pond Systems. *Water Sci. Tech.* Vol. 31, No. 12, pp. 9-20.
24. Green, F. B., Lundquist, T. J., and Oswald, W. J., 1995. Energetics of Advanced Integrated Wastewater Pond Systems. *Water Sci. Tech.* Vol. 31, No. 12, pp. 9-20.
25. Magro, D. T., 1995. Water Conservation. Naval Facilities Engineering Service Center, Port Hueneme, CA.
26. Nurodogan, Y. and Oswald, W. J., 1995. Enhanced Nutrient Removal in High-Rate Ponds. *Water Sci. Tech.* Vol. 31, No. 12, pp. 33-43.
27. U.S. Army Corps of Engineers, 1995. Alternatives for Secondary Treatment at Central Vehicle Wash Facilities. ETL 1110-3-469.
28. United States Golf Association, 1994. Wastewater Reuse for Golf Course Irrigation. Lewis Publishers, Inc., Chelsea, MI.
29. Naval Facilities Engineering Service Center, 1993. Navy Water Conservation Guide for Shore Activities. UG-2017-E&U. Port Hueneme, CA.
30. National Association of Plumbing-Heating-Cooling Contractors, 1992. Assessment of On-Site Graywater and Combined Wastewater Treatment and Recycling Systems. NAPHCC, Inc., Falls Church, VA.

31. U.S. Environmental Protection Agency, 1992. Guidelines for Water Reuse. EPA/625/R-92/004.
32. U.S. Geological Service, 1992. Gulfport, Mississippi, United States: Aerial Photo. <http://www.terraserver-usa.com>.
33. CH2M Hill, 1990. Water Reuse Health Effects. Herndon, VA.
34. Envirex, Inc., 1989. Water and Wastewater Treatment Equipment. Waukesha, WI.
35. Pettygrove, G. S. and Asano, T., 1985. Irrigation with Reclaimed Municipal Wastewater – A Guidance Manual. Lewis Publishers, Inc., Chelsea, MI.
36. U.S. Army Corps of Engineers, 1982. Process Design Manual for Land Treatment of Municipal Wastewater. EM 1110-1-501.
37. Culp, G., Wesner, G, Williams, G., and Hughes, M. V., 1980. Water Reuse and Recycling Technology. Noyes Data Corporation, Park Ridge, NJ.
38. Milne, M., 1979. Residential Water Re-use. California Water Resources Center, Davis, CA.
39. Leeds, Hill, and Jewitt, Inc., 1971. Economic and Institutional Analysis of Wastewater Reclamation and Reuse Projects. Leeds, Hill, and Jewitt, Inc., San Fransisco, CA.