

May 2003

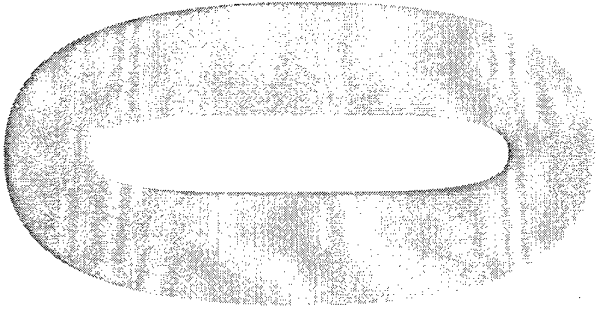

**Low Airspeed Measuring  
Devices for Helicopter  
Usage Monitoring**

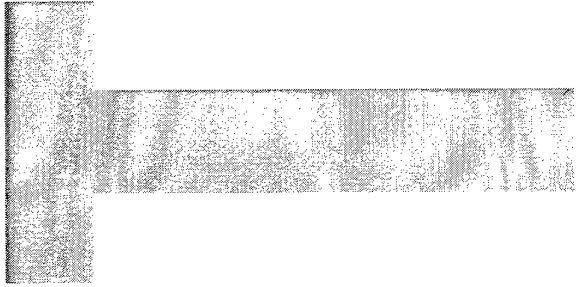

C. G. Knight

DSTO-TN-0495

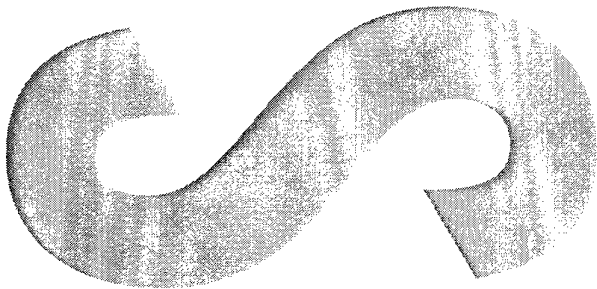

**DISTRIBUTION STATEMENT A**  
Approved for Public Release  
Distribution Unlimited

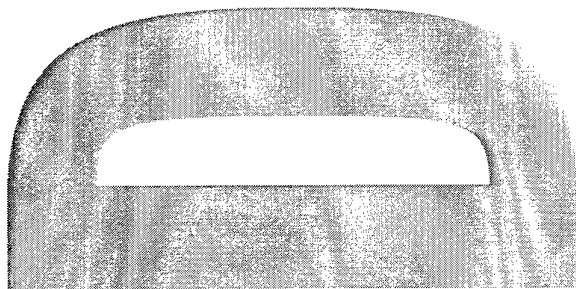

20031001 118



# Low Airspeed Measuring Devices for Helicopter Usage Monitoring Systems

*C. G. Knight*

**Air Vehicles Division  
Platforms Sciences Laboratory**

DSTO-TN-0495

## **ABSTRACT**

Low airspeed measurement is problematic on helicopters due to adverse flow fields from the rotors impinging on the standard pitot static system. A variety of alternative methods exist to measure airspeed.

This note presents a brief review of some of the low airspeed measuring devices available for aircraft and, more particularly, helicopters. This note also introduces a novel technique that was studied within Air Vehicles Division as a concept demonstrator.

## **RELEASE LIMITATION**

*Approved for public release*

AQ F03-12-2543

*Published by*

*DSTO Platforms Sciences Laboratory  
506 Lorimer St  
Fishermans Bend, Victoria 3207 Australia*

*Telephone: (03) 9626 7000*

*Fax: (03) 9626 7999*

*© Commonwealth of Australia 2003*

*AR-012-765*

*May 2003*

**APPROVED FOR PUBLIC RELEASE**

# Low Airspeed Measuring Devices for Helicopter Usage Monitoring Systems

## Executive Summary

A helicopter manufacturer usually specifies the retirement lives of fatigue life-limited structural components based on assumed usage spectra. This is dependent on the aircraft's mission profile and measured flight loads. A more accurate method measures the actual, in-service, usage. This method, Usage Monitoring, aims to identify how the helicopter is being used and then estimates how much fatigue life remains for specific components before they need to be replaced.

One of the key parameters for Usage Monitoring is the helicopter's airspeed. Unfortunately traditional methods of measuring airspeed, such as the pitot-static system, often do not work below 30-45 kt. As some low speed manoeuvres, such as hover, sideward and rearward flight, do significant damage to components in terms of fatigue life accrual, it is important that low airspeed be measured accurately.

No current Australian Defence Force (ADF) helicopters have low airspeed indicators. However, low airspeed measurement is critical on attack helicopters, due to the low speed targeting requirements. The ADF is about to start operating an attack helicopter, the Eurocopter *Tiger*. Thus knowledge of low airspeed methodologies will also aid in the introduction to service of this new platform.

This report outlines some potential methods for measuring low helicopter airspeeds, where the normal airspeed sensing system does not work adequately.

In addition to a review of available methods, some additional work in this area was completed as part of a proof-of-concept demonstrator. A simple variable incidence anemometer was designed and tested in the low airspeed wind tunnel at the Platform Sciences Laboratory.

# Contents

1. INTRODUCTION.....	1
2. HELICOPTER AIRSPEED MEASUREMENT.....	2
3. MECHANICAL METHODS OF ANEMOMETRY.....	3
3.1 Gimballed Methods.....	3
3.2 Other Mechanical Systems.....	4
4. NON-MECHANICAL METHODS.....	5
4.1 GPS as a Low Airspeed sensor. ....	5
4.2 Other Non-Mechanical Methods.....	6
4.2.1 Algorithm Method.....	7
4.2.2 The Neural Network Approach.....	7
5. AN EXAMPLE OF MECHANICAL ANEMOMETRY .....	9
6. THE OPTICAL AIR DATA SYSTEMS LANCE.....	10
7. CONCLUSION.....	12
8. ACKNOWLEDGEMENTS .....	13
9. REFERENCES .....	13
APPENDIX A: EXAMPLES OF PATENTED MECHANICAL STYLE ANEMOMETERS.....	15
APPENDIX B: EXAMPLES OF PATENTED ALGORITHM BASED ANEMOMETERS.....	21

## 1. Introduction

An aircraft manufacturer usually specifies the retirement lives of fatigue life-limited structural components based on assumed usage spectra that are dependent on the aircraft's mission profile and measured flight loads. Over their service life, Australian Defence Force (ADF) helicopters are often not used in the same mission profile as assumed when they were designed. In addition, the size of the ADF fleet for any given platform often does not warrant recalculation by the original equipment manufacturer (OEM).

These differences in usage spectra have implications for the retirement lives assigned to components. The calculated lives could be too high, leading to safety concerns, or too low, leading to higher than necessary operating costs. A means of determining the actual damage incurred by components is therefore desirable. One possible solution is to monitor the mission profile of the helicopters and recalculate the retirement times based on the actual type of flying undertaken. This monitoring could be continuous or done at intervals. A monitoring device could be installed that establishes the type and duration of manoeuvres flown allowing for an adjustment of the retirement lives of the components. This process is known as Usage Monitoring.

Usage Monitoring aims to identify how the helicopter is being used and then estimate how much fatigue life remains for specific components before they need to be replaced. There are two main ways of conducting usage monitoring; loads monitoring and flight condition monitoring. Flight condition monitoring is the more common method, and involves the recording of various aircraft parameters from which flight conditions can be deduced. To convert information about flight conditions into fatigue damage for a particular component, a relationship is required between each flight condition and the resulting flight loads on that component. This relationship is generally obtained by conducting a comprehensive flight test program on a fully instrumented aircraft. The aircraft is flown through each flight condition and the required component loads are recorded.

A key parameter for flight condition monitoring is the helicopter's airspeed. Knowledge of the airspeed is therefore important. Unfortunately traditional methods of measuring airspeed, such as the pitot-static system, often do not work below 30-45 kt. As some manoeuvres such as hover, sideward and rearward flight do significant fatigue damage to components it is important that low airspeed be able to be measured accurately.

Low airspeed measurement is also important on attack helicopters, such as the Eurocopter *Tiger*, Bell *Cobra* and Boeing *Apache*, as low speed targeting requires accurate knowledge of helicopter speed.

This report outlines some potential methods for measuring low helicopter airspeeds, where the normal airspeed sensing system does not work adequately.

## 2. Helicopter Airspeed Measurement

Airspeed is normally obtained via pitot-static tubes mounted near the front of the helicopter. If the helicopter is travelling faster than approximately 30 knots (56 km/h), then the speed indication works accurately as the pitot-static tubes are not in the downwash of the rotor system (Figure 1). However, if the helicopter is travelling at less than 30 knots then the pitot-static tubes are within the downwash from the rotor blades giving an error for the airspeed readings (Figure 2). For some helicopters, low-speed regimes are significant in terms of the fatigue damage experienced by components.

Low-speed regimes consist of hover, low-speed forward, sideways, and rearwards flight.

Since the readings from the pitot-static tubes are not reliable at speeds below 30 knots, other methods of determining the helicopter's speed are required.

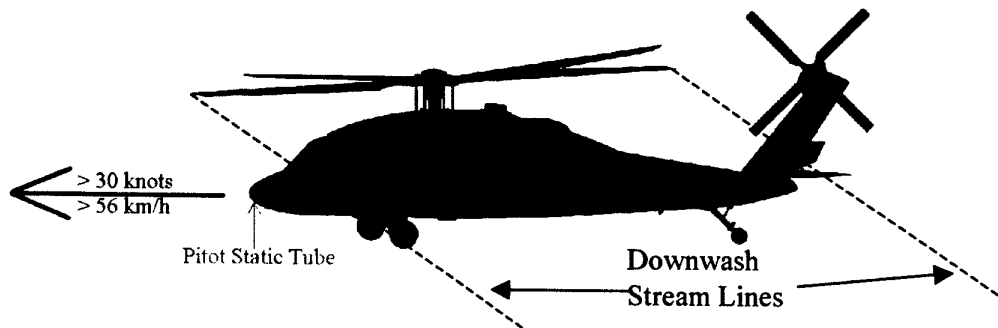

Figure 1: Speed greater than 30 knots - downwash has no effect on pitot-static tube readings (Ref. 1)

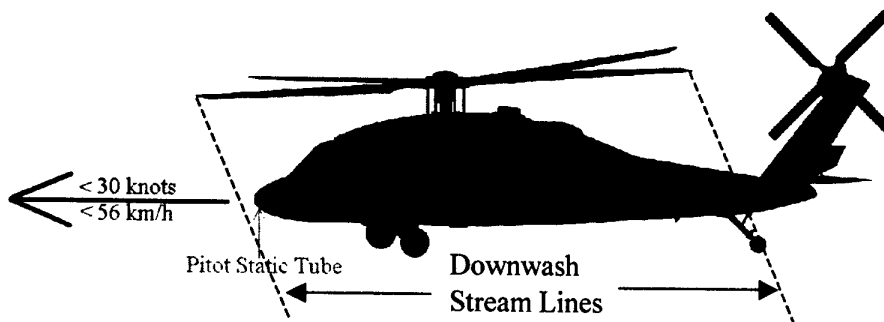

Figure 2: Speed less than 30 knots - downwash affects pitot-static tube readings (Ref. 1)

Some methods that have been researched include using the Global Positioning System (GPS) to measure ground speed (Ref. 1). The methodology behind this is discussed briefly in Section 4.

Some other possible solution to the problems of low airspeed sensing lies in methods such as mechanical anemometry or laser based anemometry methods. Both these methods will be discussed in this report.

### 3. Mechanical Methods of Anemometry

Development of mechanical methods of accurately estimating low airspeed began in the 1950s when preliminary concepts were developed and flight-tested. These systems involved mounting sensors above the rotor hub as well as in the wake beneath the rotor. The sensor has generally been a rotating anemometer, pitot tube, accelerometer or pressure transducer.

In general these methods rely on gimbaling the sensor to measure local wind speeds and directions or taking averaged airspeed measurements from less turbulent areas of airflow around the helicopter and calibrating this to true airspeed.

#### 3.1 Gimballed Methods

The main source of error in a pitot-static system of airspeed measurement is that the pitot tube is no longer aligned with the direction of airflow. A general solution to this problem is to allow the pitot tube to align itself with the local airflow and then calibrate the system to read corrected helicopter airspeed. Figures 3 and 4 show one such system as mounted on the Boeing AH-64D *Apache*. The system is mounted in dual on arms that extend outward from the top of each engine cowling, as indicated by the arrows.



Figure 3. An example of mechanical anemometry onboard the Boeing Apache AH-64D. (Picture from [www.boeing.com](http://www.boeing.com))

The basis of the LORAS (Low Range Airspeed Sensor) system is shown in Figure 4. It is a standard pitot-static system mounted on a gimbal that allows the system to rotate in line with the local airflow. A circular vane that acts like a weathercock aids the

alignment. The angle of the sensor can then be measured and a calibrated airspeed signal is produced.

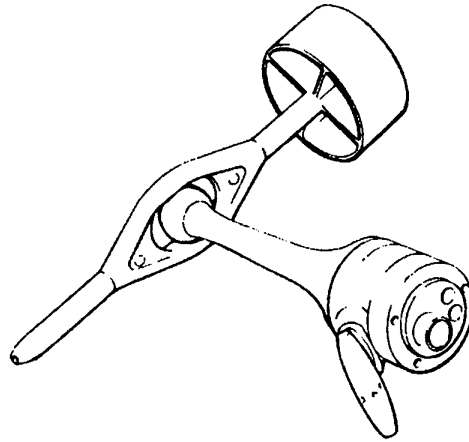

Figure 4. The LORAS low airspeed measuring system (Ref. 2).

This style of low airspeed measurement is used on some attack helicopters such as the Apache and the Bell AH-1Z Cobra. However, the Cobra appears to only use one system mounted on an arm above the cockpit. Here the flow field is perhaps more uniform, and thus a backup is not required. The system costs approximately US\$110000.

### 3.2 Other Mechanical Systems.

Other mechanical systems exist which measure airspeed using a variety of methods. For example the Omni Directional Air Data System (OADS) uses two venturi tubes on opposite ends of a rotating arm. This system is installed above the rotor hub to measure the magnitude and direction of the local airspeed. The differential pressure between the two sensors is used to calculate the airspeed and sideslip angle.

A similar Russian system, mounted on the Mi-28 *Havoc* attack helicopter, has pitot tubes on the end of the rotor blades rather than as a separate system (Ref. 2).

A brief search of the US Patent Office reveals numerous examples of mechanical systems for measuring low airspeed. There are many similar systems, with varying degrees of accuracy and capability. Appendix A contains the cover page from similar patented systems. Patent 5874673 (February 1999) uses an accelerometer mounted on a swinging arm in phase with the main rotor. The amplitude of the sensor peaks corresponds to airspeed and the phase of the peaks is an indication of the direction of the aircraft.

Patent 4893261 (November 1987) is a system that uses the sinusoidal variations of pressure on the rotor along with a Fourier Transform analysis to determine aircraft velocity. Of note here is that the assignee is United Technologies Corporation. This company is the owner of Sikorsky and manufactures the various Hawk helicopters, of which the *Black Hawk* and *Seahawk* are in Australian military service.

Often these mechanical systems require slip ring assemblies or some other means of transferring data from the rotating reference frame of the rotor to the fixed reference frame of the fuselage.

Patent 5299455 (March 1992) attempts to account for this by measuring the air velocity from the three major axis directions with standard hot-wire anemometry. If this system was calibrated accurately then it should be as accurate as the gimballed pitot tubes discussed above. However hot-wire anemometers are prone to fouling due to insects and dust in the air. Thus it is not clear how effective this system would be in a real helicopter.

## 4. Non-Mechanical Methods

### 4.1 GPS as a Low Airspeed sensor.

The Global Positioning System (GPS) can be used to obtain a helicopter's ground speed. However, as the required parameter for flight regime recognition is airspeed, not ground speed, the use of the GPS as a system for measuring low airspeed will require knowledge of the wind speed. The relationship between airspeed and ground speed is a simple vector sum as shown in Figure 5.

A possible solution for determining wind speed, whilst the helicopter is flying at speeds greater than 30 knots, is to obtain the airspeed from the pitot system and the ground speed from the GPS, and then determine the wind speed vector. Assuming that the wind speed stays relatively constant during short periods whilst the helicopter is travelling below 30 knots, an estimation of the airspeed can be obtained via the GPS by removing the last wind speed vector from the GPS ground velocity.

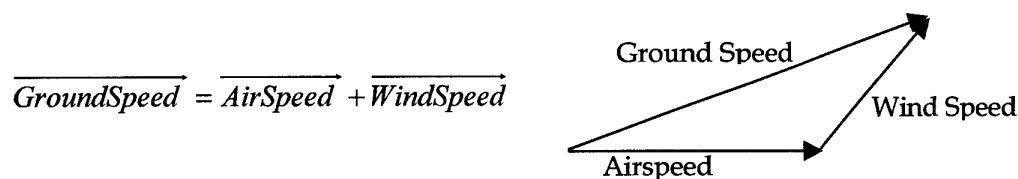

Figure 5: Relationship between Airspeed and Ground Speed

The accuracy of this system is dependent on the ability of the GPS to accurately measure ground velocity and the validity of the assumption that the wind speed vector is relatively constant during the times that the airspeed decreases below 30 knots.

A field trial with a GPS unit, mounted in an automobile, at the Army Test and Evaluation Agency (ATEA) testing grounds, at Monegeetta, Victoria (Ref. 1), proved that the GPS could be used. As noted below, this system did have some limitations. The velocity results obtained via the GPS matched well with the measured velocity of the vehicle even in a dynamic environment. Some observations from the trial were:

- The velocity solution can momentarily become inaccurate whilst switching between satellites. The problems of inaccuracy that arise whilst changing satellites may be reduced in updated GPS receivers which now routinely track up to 12 satellites or by receivers designed for use in a dynamic environment.
- The loss of a satellite, from four to three, provides fewer problems than the switching of satellites as described above.
- The algorithms used must be able to handle the transient and sometimes erratic results that a GPS outputs when it switches satellites. One possible solution is to ignore the GPS output for a certain period of time when the sensor detects that the GPS has switched satellites.
- The time lag measured between the vehicle speed and the GPS speed is several times greater than that claimed by the manufacturer of the GPS. The lag is large, but still acceptable. Newer GPS receivers will certainly be better in this regard.
- The possible loss of GPS signal in a dynamic and obscured environment, such as nap-of-the-earth flying and hovering amongst tree cover.
- The use of the GPS for a low-air-speed sensor requires an assumption that wind speed is constant during slow speed flight regimes for short periods of time. This assumption has not been tested and would need to be validated before a GPS system could be used.

A fuller review of the investigation into the use of GPS for low airspeed sensing is contained in Ref. 1.

## **4.2 Other Non-Mechanical Methods**

The previous search of the US Patent Office revealed a number of non-mechanical methods of low airspeed anemometry. Each of these methods can be classified as using either an algorithm approach or a neural network. There is one other type of non-mechanical method, which uses a laser beam. That method is covered in more detail in the next section.

The cover page from a selection of these patents is contained in Appendix B. A search of other patent offices, such as the British or European Patent Offices is expected to reveal similar airspeed anemometry methodologies.

#### 4.2.1 Algorithm Method

The algorithm method consists mainly of measuring various aircraft state parameters such as altitude, pitch and roll angle, accelerations, and various control positions. These values are inputs to previously calculated equations, which reduce to indications of airspeed and, often, sideslip angle.

Appendix B contains a number of patents for algorithm based anemometers found at the US Patent Office website. These represent only a small portion revealed by the search.

A number of very interesting approaches have been tried and patented. The measure of seriousness of this problem is indicated as much as anything by the company names that the patents are assigned to.

Patent 5750891, which was assigned to GKN Westland Helicopters in 1996, is a method of deducing airspeed from a measurement of radial air flow on the blade and the rotational velocity of the blade. This gives an indication of sideslip angle. This angle is then compared with a database of values that correlates the sideslip angle with airspeed.

Patent 4300200 was assigned to the precursor of GKN Westland Helicopters, Westland Aircraft Limited in 1979. The basic methodology here is to measure the instantaneous weight and power of the helicopter and compare these values with a database of known airspeed, weight and power characteristics.

Many other patents consist of a similar system to that identified in Patent 4794793 from 1989. The basic methodology is to measure the various control (cyclic, collective and pedal) positions and use these as inputs to an algorithm that outputs airspeed. Patent 5214596 from 1993 is a variation on this theme.

#### 4.2.2 The Neural Network Approach

The neural network approach of airspeed estimation is very similar to the algorithm approach. That is, various state parameters are measured and an indication of airspeed is calculated. The main difference is in the method of calculation. Neural nets need to be "taught" the methodology for calculation. As an initial input, a series of known parameters and known correct airspeeds are used to train the neural net.

Once this is achieved a series of tests are run which allow the trainer to estimate if the neural network has sufficiently learnt the methodology or needs additional training in order to be more accurate.

Once the neural network has been successfully trained, the values gathered in service can also be used to give additional knowledge to the neural net.

The first of the neural network approaches to airspeed estimation in Appendix B is Patent 5901272. This patent was assigned to The US Navy and is based on work presented in Ref. 4. The remaining neural network based system for airspeed estimation is Patent 5063777, assigned to Sextant Avionique. The patents shown in Appendix B are very similar in methodology. The main differences are in the different parameters used to calculate the airspeed and in how the information is presented to the pilot. Some detail of the methodology is provided in References 4 and 5.

The testing outlined in Ref. 4 was performed using a tandem rotor CH-46 *Sea Knight*. The accuracy noted for the 1996 tests shows some promise. The in-ground-effect (IGE) was within 10 kt and the out-of-ground-effect (OGE) was within 6 kt. Of note is that the reference airspeed was only accurate to 5 kt. So both these results are well within the accuracy for Helicopter Usage Monitoring System (HUMS) requirements.

The training data for the airspeed sensor components of the neural network used in the 2002 report (Ref. 5) was obtained during test flights performed at very low prevailing wind speeds. This allowed the use of groundspeed measuring devices to effectively measure airspeed. A number of different flights were completed with 4.5 hours of total flight time captured. This involved flight in all directions (forward, sideways and rearward) and during both in-ground and out-of-ground flight.

The results from Ref. 5 are an improvement on those from Ref. 4. The main differences seem to be the application of various filters. The final root mean squared error of the data was 3.4 knots. The error increases markedly when the airspeed is below 5 knots or above 35 kt. No differences between OGE and IGE are noted in Ref. 5.

Ref. 6 is based on work with a Westland *Mk9 Lynx*, which is a single rotor helicopter. The University of Warwick, CSE International and GKN Westland Helicopters performed the work. The results from this study were more accurate with an error of 3 kt and the paper also notes a degradation of the accuracy whilst at IGE altitudes.

The inputs for the Ref. 6 study consisted of the four major controls, all angular positions and rates (pitch, roll and yaw) and pitch and roll angular accelerations, rate-of-climb, rotor torque, aircraft mass and CG position. While most of these can be obtained from aircraft instrumentation, it is not clear how accurately aircraft mass and CG position are known throughout the test flight period.

## 5. An Example of Mechanical Anemometry

The search of available techniques revealed a number of issues. Firstly the available methods often got no further into production than a patent or a journal / conference paper. Secondly, those that actually went into manufacture were very expensive. For example, the LORAS system presented earlier in this document costs approximately US\$110000. The actual cost of the unit is difficult to determine as it is usually sold as part of the helicopter. Unfortunately, this cost was well outside that allowing AVD to purchase and test the system.

A decision was made to design and test a simple mechanical anemometer. The design is very basic. Figure 6 shows a picture of the final design. When mounted in a moving airstream, the turbine rotates. After calibration the RPM of the turbine represents a known wind speed. Due to the weathercocking effect, the axis of the anemometer points directly into the wind. Thus the anemometer provides an indication of local airspeed.

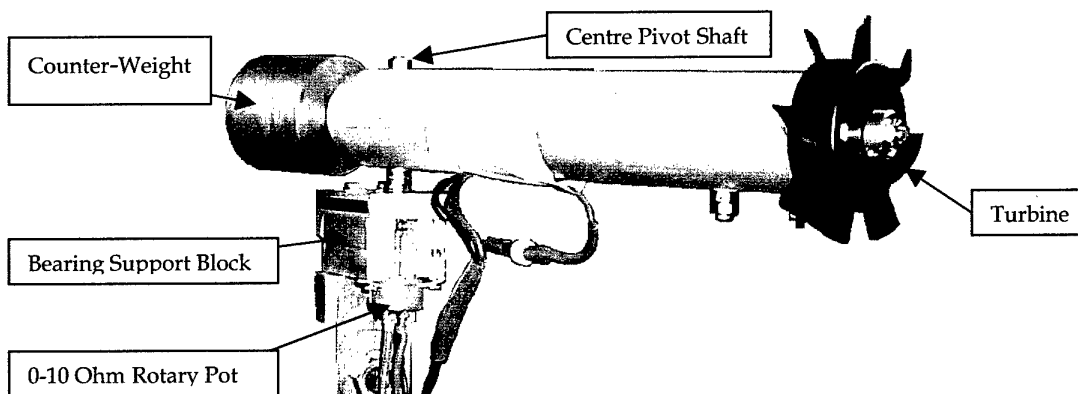

Figure 6. Major components of the AVD designed mechanical anemometer.

The counter-weight is mounted on a screw that allows the Centre of Gravity (CG) of the anemometer to be adjusted. For the purpose of the reported experiments, the CG was adjusted to coincide with the centre pivot shaft. This eliminated any turning moment that can be caused by the vehicle's acceleration.

The bearing support block carries the centre pivot shaft down to a coupling connecting the shaft with the 0-10 Ohm rotary potentiometer. The potentiometer allows the direction of the anemometer to be determined relative to some initial axis.

The turbine is a computer power supply fan. The turbine is mounted on a shaft (inside the anemometer), which is connected to a slotted disk. The disk has 2 diametrically opposed slots providing a twice per revolution tacho signal.

For wind tunnel testing, and for the testing while mounted on a car, it was only necessary to have the anemometer capable of full rotation about the vertical axis, as both of these environments were essentially two-dimensional, since no vertical wind was anticipated. This device was not designed to be tested while mounted on an aircraft; to do so would require an additional mount to allow rotation about the pitching axis of the device.

One early concern was that the device would be unstable about the vertical axis and oscillate in yaw. Both wind tunnel testing and preliminary car testing did not indicate this problem. In fact, the device proved to be very stable at all speeds up to 25 m/s (50 knots).

After completion of the wind tunnel tests, informal car trials were completed to indicate the oscillatory stability of the system in gusty and turbulent conditions. The AVD Anemometer was visually tracked during these trials and its performance was considered satisfactory to continue further testing. As in the wind tunnel testing, no unstable oscillations were observed up to the maximum test speed of 100 km/h.

At that stage, a complete set of fully instrumented car mounted tests were being planned. However, at about this time, the Optical Air Data Systems LANCE details were found in Ref. 7. This system is detailed in Section 6 below. Its reported performance, low weight and low projected cost would make this system ideal for a low airspeed sensor for helicopter applications. Because of this, we have decided not to invest further effort in pursuing the car trials of the AVD Anemometer, but to report existing results to date.

## **6. The Optical Air Data Systems LANCE**

The Optical Air Data Systems (OADS) Laser Night/day Combat and Training Engagement (LANCE) system is a system originally developed to estimate range, target wind velocity and muzzle velocity for the 30mm cannon carried by amphibious assault vehicles (AAV).

The same basic principles evolved into a system to aid snipers in estimating wind speed at the target. Extensive use of fibre optics and laser diodes has led to a device that weighs 500 grams and costs around US\$2500. The system it replaces weighs 2.6 kg and costs US\$11000 (Ref. 7).

The next stage of development is as a down-range wind sensor for US Navy Landing Craft Air Cushion (LCAC). This is a similar application to the initial fit out on the Bushmaster amphibious assault vehicles (AAV). One of the major advantages of the LANCE application to both the AAV and LCAC is that the system is mainly solid state with very few mechanical components. This is particularly relevant to the salt laden

atmosphere that the system operates in (Ref. 7). It also lends itself to the shipborne helicopter operations.

The system has found applications with tilt rotor aircraft. The V-22 Osprey is to trial the system in an effort to avoid the low speed phenomena of vortex ring state (VRS), or "settling with power".

VRS occurs when a helicopter is at low forward speed with a high rate of descent. In this condition some portion of the airflow is upwards through the disk. To escape from this state the pilot is required to reduce collective (and thus power) and gain forward airspeed. Critical to recovery is the need for altitude. Unfortunately VRS occurs often on approach to landing (Ref. 2).

The situation is even more critical on the V-22 as the two rotors may not enter VRS at the same time. This will cause a rolling moment to develop. Although the conditions at which VRS occurs are easily identified there is presently no way to provide information on airspeed to the pilots because of the limitations of the pneumatic system used. The LANCE system hopes to be able to provide the information on airspeed and thus avoid VRS. This will allow the V-22 to remove its current limitation of 800 feet per minute descent rate (Ref. 7).

Unfortunately, repeated requests for further information from Optical Air Data Systems have not been answered. The referenced article (Ref. 7) and the company's website ([www.oads.com](http://www.oads.com)) contain little in the way of technical information. What little is available indicates that the system is based on an Erbium laser.

## 7. Conclusion

This note has presented a review of some of the available technologies applied to low airspeed indication on helicopters. For the purpose of this document low airspeed has been defined as below 45 knots. However, in general it is that speed at which the standard pneumatic system (pitot static tube) will cease to function reliably on a helicopter.

A number of different approaches have been studied. These approaches fall broadly into two categories. The first comprises the mechanical methods. These include systems mounted dynamically, which are thus able to swivel into the local wind direction and give a more accurate reading of local airspeed. Other mechanical methods include systems based on accelerometers, or pressure transducers, which are used to deduce local conditions. These local conditions are then calibrated back to a global speed for the helicopter.

The second broad category is the non-mechanical system. These include GPS and laser based systems, algorithm systems and neural networks. Both algorithm and neural network systems are similar in that various state parameters are measured and airspeed is calculated. The main difference between the two is in the method of calculation. The algorithm method uses a set equation to convert the inputs into airspeed, whilst the neural network needs to be taught the appropriate parameters but is able to be more flexible in the application.

In the final part of this note two case studies were presented. The first was an example of a mechanical system that was designed and tested within AVD. It was found to be of reasonable accuracy, but was not tested in a real application on board a helicopter.

The second case study was on a laser based system, designed by Optical Air Data Systems. Although this system has not yet been fully applied to the problem of low airspeed indication on board helicopters, the manufacturer's claim shows great promise in providing a low cost, low weight and accurate alternative to current pneumatic based systems, at all speeds.

## 8. Acknowledgements

The author would like to thank Mr Scott Dutton for his electronic design skills and Mr Soon-Aik Gan for his extensive programming expertise.

## 9. References

- 1) **Application of GPS to Low Airspeed Measurement for Helicopter Usage Monitoring Systems**, SA Gan, SA Dutton, CG Knight, DSTO TN-0428, 2002.
- 2) **The Art and Science of Flying Helicopters**, S. Coyle, Iowa State University Press, 1996.
- 3) **A Method Of Helicopter Low Airspeed Estimation Based On Measurement Of Control Parameters**, AJ Faulkner and S Attlefellner, Paper Presented at the 5<sup>th</sup> European Rotorcraft and Powered Lift Aircraft Forum, Amsterdam, September 1979.
- 4) **A Neural Network Based Approach To Helicopter Low Airspeed And Sideslip Angle Estimation**, KM McCool, DJ Haas and CG Schaefer Jr. Paper number 96-3481 in Proceedings of the American Institute of Aeronautics and Astronautics Flight Simulation Technologies Conference, July 1996.
- 5) **A Virtual Sensor System For Helicopter Usage Monitoring**, OH Ben-Zeev, DJ Haas and MA Morales, Paper Presented At The American Helicopter Society 58<sup>th</sup> Annual Forum, Canada 2002.
- 6) **Predicting Airspeed And Sideslip Angle Using An Artificial Neural Network**, DA Goff, SM Thomas, RP Jones and CP Massey, Paper Presented At The American Helicopter Society 55<sup>th</sup> Annual Forum, Canada 1999.
- 7) **Catch The Wind**, JG Roos, Armed Forces Journal, February 2002.
- 8) **The Measurement of Airflow**, 5<sup>th</sup> Edition, E. Ower and RC Pankhurst, Pergamon Press, 1977



## **Appendix A: Examples of Patented Mechanical Style Anemometers.**



US005874673A

**United States Patent** [19]  
**Greene**

[11] **Patent Number:** 5,874,673  
[45] **Date of Patent:** Feb. 23, 1999

[54] **AIR SPEED AND DIRECTION INDICATING SYSTEM FOR ROTARY WINGED AIRCRAFT**

[75] **Inventor:** Leonard M. Greene, Scarsdale, N.Y.

[73] **Assignee:** Safe Flight Instrument Corporation, White Plains, N.Y.

[21] **Appl. No.:** 839,394

[22] **Filed:** Apr. 11, 1997

[51] **Int. Cl.<sup>5</sup>** ..... G01C 21/12

[52] **U.S. Cl.** ..... 73/178 H; 73/170.02; 73/170.11

[58] **Field of Search** ..... 73/178 H, 170.02, 73/170.11

[56] **References Cited**

**U.S. PATENT DOCUMENTS**

2,524,747	10/1950	Ayres et al.	
2,531,521	11/1950	Link	
2,952,154	9/1960	Traksel	
3,332,282	7/1967	Daw	
3,589,831	6/1971	Lemnios	416:24
3,638,885	2/1972	Reed	244/17.27

3,726,139	4/1973	Beilman	73:181
4,334,823	6/1982	Sharp	416:119
4,360,888	11/1982	Onksen et al.	364:565
4,648,269	3/1987	Durand	73:178
4,697,986	10/1987	David	416:114
4,766,767	8/1988	Hassenpflug et al.	73:181
4,893,261	1/1990	Flint, III et al.	364:565
5,063,777	11/1991	Arctzens et al.	73:178
5,229,956	7/1993	Daniell et al.	364:567
5,239,468	8/1993	Sewersky et al.	364:424.03
5,440,193	8/1995	Barrett	340:328

*Primary Examiner*—Joseph L. Felber  
*Attorney, Agent, or Firm*—Dougherty & Troxell

[57] **ABSTRACT**

An airspeed and direction indicating system for an aircraft of the rotary wing type includes a vertical accelerometer for monitoring the up and down movement of an outer portion or tip of the rotary wing. The vertical accelerometer produces a generally sinusoidal signal in response to the up and down movement of the wing tip as it rotates about an axis. The amplitude of the signal corresponds to the airspeed and the phase angle indicates direction. Suitable readouts display the information for consideration by a pilot.

**10 Claims, 4 Drawing Sheets**

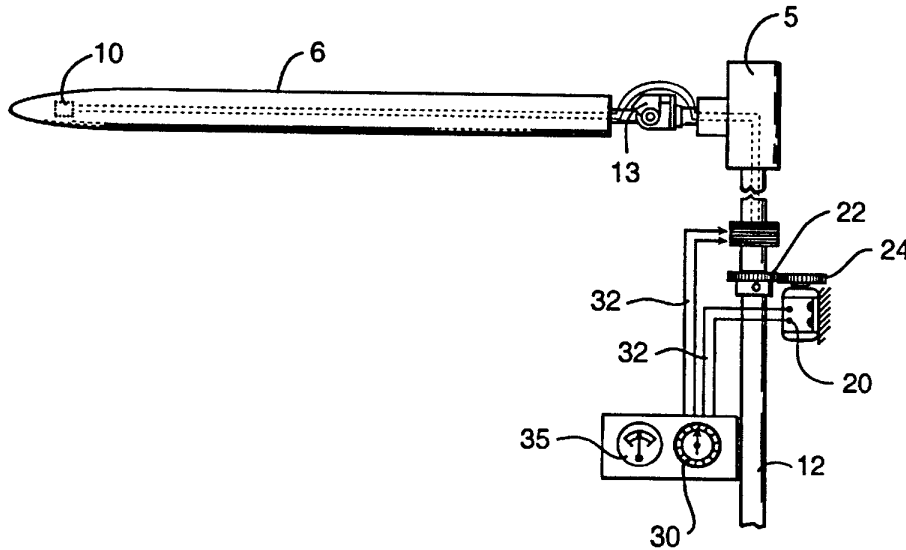



US005299455A

**United States Patent** [19]  
**Mangalam**

[11] **Patent Number:** 5,299,455  
[45] **Date of Patent:** Apr. 5, 1994

[54] **METHOD AND INSTRUMENTATION SYSTEM FOR MEASURING AIRSPEED AND FLOW ANGLE**

[76] **Inventor:** Siva M. Mangalam, 17 Mile Course, Kingsmill on the James, Williamsburg, Va. 23185

[21] **Appl. No.:** 860,780

[22] **Filed:** Mar. 27, 1992

[51] **Int. Cl.:** G01C 21/00; G01F 1/68

[52] **U.S. Cl.:** 73/180; 73/181; 73/204.11

[58] **Field of Search:** 73/180, 181, 204.11, 73/147; 340/966, 968, 969

[56] **References Cited**

**U.S. PATENT DOCUMENTS**

2,923,152	2/1960	Mabry et al.	73/179
3,069,906	12/1962	Eiland, Jr.	73/180
3,082,622	3/1963	Andrew	73/180
3,443,431	5/1969	Hagen	73/178
3,475,958	11/1969	Sabadishin et al.	73/180
3,482,445	12/1969	Leo et al.	73/182
3,500,685	3/1970	Gwathmey	73/180
3,646,811	3/1972	DeLeo et al.	73/182
4,230,290	10/1980	Townsend et al.	244/1 R
4,428,549	1/1984	Halliday et al.	244/1 R

4,563,684	1/1986	Maris	73/147
4,672,846	6/1987	LeBlond et al.	73/180

*Primary Examiner*—Donald O. Woodiel  
*Attorney, Agent, or Firm*—Raymond L. Greene

[57] **ABSTRACT**

An instrumentation system for measuring airspeed and angle-of-attack (AOA) is provided. The system includes a sensor assembly, a constant voltage anemometer, a microprocessor assembly with software, and an output device suitable for powering conventional cockpit display or for powering other speed AOA devices such as engine inlets and stability augmenters. The sensor assembly is a pair of orthogonal miniature cylinders with embedded micro-thin multielement hot film sensors. Operation of the sensor assembly by the constant voltage anemometer provides detection of cylinder leading edge flow stagnation point and oscillatory frequency. The stagnation point determination provides angle-of-attack data; the oscillatory flow frequency provides data to calculate cylinder shed-vortex frequency which is converted to airspeed data. The sensor assembly is solid-state, having no ports, diaphragms or moving parts and is heated in normal operation.

15 Claims, 11 Drawing Sheets

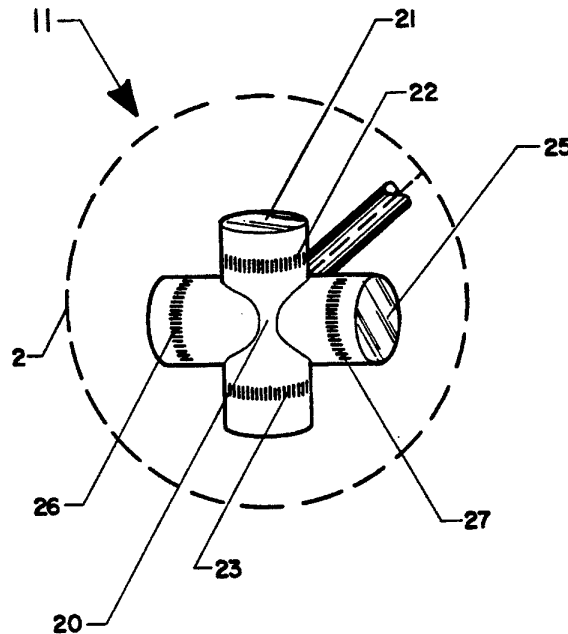

**United States Patent** [19]  
**Flint, III et al.**

[11] **Patent Number:** 4,893,261  
 [45] **Date of Patent:** Jan. 9, 1990

- [54] **APPARATUS AND METHOD FOR DETERMINING AIRSPEED AND DIRECTION**
- [75] **Inventors:** William W. Flint, III, West Hartford; Richard C. Filipkowiak, Glastonbury, both of Conn.
- [73] **Assignee:** United Technologies Corporation, Hartford, Conn.
- [21] **Appl. No.:** 123,421
- [22] **Filed:** Nov. 20, 1987
- [51] **Int. Cl.:** G01C 21/00
- [52] **U.S. Cl.:** 364/565; 73/182; 73/178 H; 416/31; 244/17.13
- [58] **Field of Search:** 73/182, 178 H, 178 R; 364/440, 565; 416/31; 244/17.13

- [56] **References Cited**  
**U.S. PATENT DOCUMENTS**  
 3,332,282 7/1967 Daw ..... 73/182  
 4,360,888 11/1982 Onksen et al. .... 73/182  
 4,519,743 5/1985 Ham ..... 416/31

*Primary Examiner*—Thomas H. Tarcza  
*Assistant Examiner*—David Cain  
*Attorney, Agent, or Firm*—Francis J. Maguire, Jr.

[57] **ABSTRACT**  
 Aircraft speed and direction are determined by sampling the sinusoid-like pressure variations at the end of a rotor and performing a Fourier analysis on the pressure samples. Fourier quadrature component signals are used to determine aircraft direction and are also used to determine, along with a steady state component, the aircraft's total velocity. A discrete Fourier analysis may be performed on the pressure samples using a plurality of subrevolution pressure samples averaged over each subrevolution interval.

16 Claims, 6 Drawing Sheets

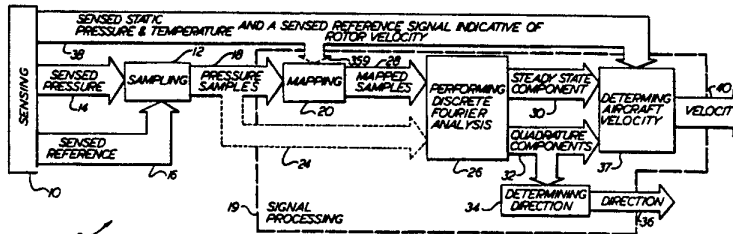

**United States Patent** [19]  
**Nakamura**

[11] **Patent Number:** 4,483,191  
 [45] **Date of Patent:** Nov. 20, 1984

[54] **AIRSPPEED INDICATOR FOR LOW-SPEED CONVEYANCES**

3,406,570 10/1968 White ..... 73/861.85  
 4,136,562 1/1979 Crooker ..... 73/187

[75] **Inventor:** Shuji Nakamura, Komae, Japan

*Primary Examiner*—Donald O. Woodiel  
*Attorney, Agent, or Firm*—Spencer & Frank

[73] **Assignee:** Tokyo Aircraft Instrument Co., Ltd., Komae, Japan

[57] **ABSTRACT**

[21] **Appl. No.:** 434,414

An airspeed indicator for low-speed conveyances which comprises a thin cylindrical hood, a generator supported at the center within the hood and a propeller mounted on the driving shaft of the generator. An indicating means for indicating the magnitude of the airspeed on a scale plate with a pointer is also provided, the pointer being rotated in proportion to the current through an ammeter coupled to the output of the generator. Means for supporting the hood is further provided, the means holding the hood so that when the indicating means is mounted on the low-speed conveyance, the hood may be fixed to face the flight direction.

[22] **Filed:** Oct. 14, 1982

[30] **Foreign Application Priority Data**

Aug. 6, 1982 [JP] Japan ..... 57-119484[U]

[51] **Int. Cl.:** G01C 21/10

[52] **U.S. Cl.:** 73/187

[58] **Field of Search:** 73/187, 189, 861.85

[56] **References Cited**

**U.S. PATENT DOCUMENTS**

439,442 10/1890 Thorne et al. .... 73/187  
 2,549,754 4/1951 Bosch ..... 73/498  
 2,742,783 4/1956 Jasse ..... 73/861.85

**11 Claims, 16 Drawing Figures**

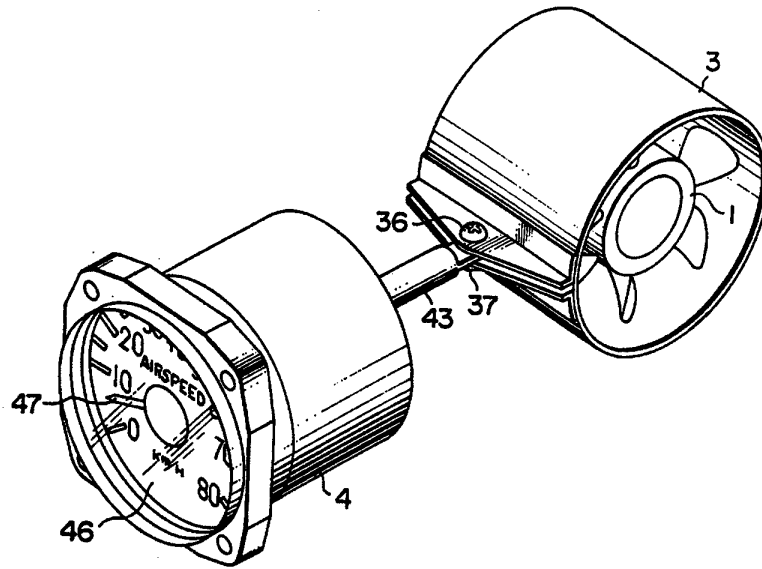



## **Appendix B: Examples of Patented Algorithm Based Anemometers.**



US005901272A

**United States Patent** [19]

Schaefer, Jr. et al.

[11] **Patent Number:** 5,901,272

[45] **Date of Patent:** May 4, 1999

[54] **NEURAL NETWORK BASED HELICOPTER LOW AIRSPEED INDICATOR**

[75] **Inventors:** Carl G. Schaefer, Jr., Woodbridge, Va.; Kelly M. McCool, University Park; David J. Haas, North Potomac, both of Md.

[73] **Assignee:** The United States of America as represented by the Secretary of the Navy, Washington, D.C.

[21] **Appl. No.:** 08/736,176

[22] **Filed:** Oct. 24, 1996

[51] **Int. Cl.<sup>9</sup>** ..... G06F 15/18

[52] **U.S. Cl.** ..... 395/22; 706/17; 706/21; 701/7

[58] **Field of Search** ..... 395/22, 27; 701/7, 701/120, 121; 244/17.11; 73/178 H, 178 T

[56] **References Cited**

**U.S. PATENT DOCUMENTS**

4,023,409	5/1977	Durand	73/178 II
4,300,200	11/1981	Doe	364/565
4,702,106	10/1987	Hassenpflug et al.	73/181
4,794,793	1/1989	Faure et al.	73/178 II
4,829,441	5/1989	Mandle et al.	364/434
4,893,261	1/1990	Flint, III et al.	364/565
5,063,777	11/1991	Arethens et al.	73/178 II
5,214,596	5/1993	Muller	364/565
5,606,505	2/1997	Smith et al.	701/99
5,654,890	8/1997	Nicosia et al.	701/16
5,710,559	1/1998	Krogmann	340/963

**OTHER PUBLICATIONS**

McCool, Kelly M., David J. Haas and Carl G. Schaefer Jr., "A Neural Network Based Approach to Helicopter Low Airspeed and Sideslip Angle Estimation," Proceedings of American Institute of Aeronautics and Astronautics Flight Simulation Technologies Conference, Paper No. 96-3481 (Jul. 29-31, 1996) pp. 91-101.

*Primary Examiner*—Allen R. MacDonald  
*Assistant Examiner*—Sanjiv Shah  
*Attorney, Agent, or Firm*—John Forrest; Gary Borda; Jacob Shuster

[57] **ABSTRACT**

The invention is directed to means, utilizing a neural network, for estimating helicopter airspeed at speeds below about 50 knots using only fixed system parameters as inputs to the neural network. The system includes: means for entering at least one initial parameter; means for measuring, in a nonrotating reference frame associated with the helicopter, a plurality of variable state parameters generated during flight of the helicopter; means for determining a plurality of input parameters based on the at least one initial parameter and the plurality of variable state parameters and for generating successive signals representing the input parameters; at least one equation representing a nonlinear input-output relationship between the input parameters and airspeed; memory means for storing the at least one equation and for successively receiving and storing signals from the determining means; and processing means responsive to signals received from the memory means for generating airspeed information based on the input parameters and the at least one equation.

20 Claims, 6 Drawing Sheets

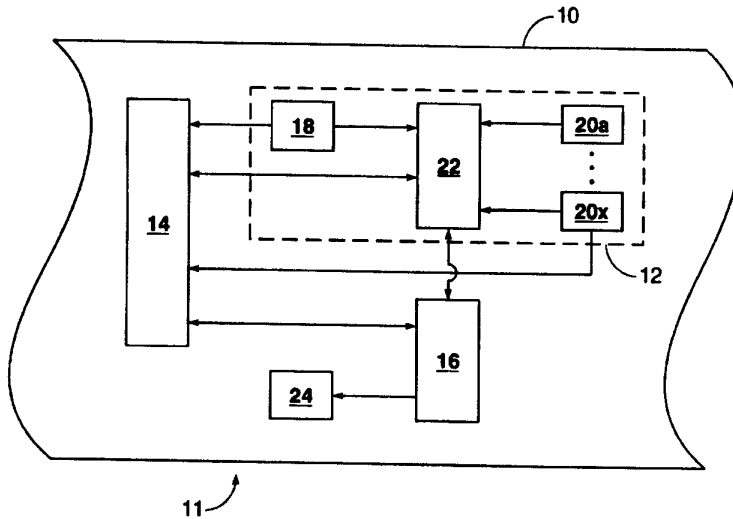



**United States Patent** [19]  
**Brocklehurst**

[11] **Patent Number:** **5,750,891**  
 [45] **Date of Patent:** **May 12, 1998**

[54] **METHOD AND APPARATUS FOR DETERMINING THE AIRSPEED OF ROTARY WING AIRCRAFT**  
 [75] **Inventor:** Alan Brocklehurst, Bradford Abbas, United Kingdom  
 [73] **Assignee:** GKN Westland Helicopters Limited, Yeovil, United Kingdom

4,648,271	3/1987	Woolf	73/204.27
4,747,305	5/1988	Evans et al.	73/182
4,856,329	8/1989	Buck et al.	73/204.26
5,050,086	9/1991	Lambrechts	244/179
5,063,777	11/1991	Arethens et al.	73/178 H

**FOREIGN PATENT DOCUMENTS**

325427 9/1920 Germany

**OTHER PUBLICATIONS**

Patent Abstracts of Japan. JP4218778. Oct. 8, 1992, vol. 16, No. 568.

*Primary Examiner*—William L. Oen  
*Attorney, Agent, or Firm*—Larson & Taylor

[57]

**ABSTRACT**

A method and apparatus for determining the airspeed of a rotary wing aircraft having a sustaining rotor with a plurality of radially extending rotor blades for rotation about a substantially vertical axis comprises the steps of measuring an airflow sideslip angle established during rotation of each rotor blade by the vector of a radial flow component due to the relative wind vector and the rotational velocity perpendicular to a blade feathering axis, producing a signal representative of the sideslip angle, comparing the signal in a processor containing information on a known relationship between the sideslip angle and airspeed, providing an output signal representative of the airspeed and wind direction to a display which may display both the airspeed and wind direction.

[21] **Appl. No.:** 711,927  
 [22] **Filed:** Sep. 11, 1996  
 [30] **Foreign Application Priority Data**  
 Sep. 14, 1995 [GB] United Kingdom ..... 9518800  
 [51] **Int. Cl.<sup>6</sup>** ..... **G01C 21/00**  
 [52] **U.S. Cl.** ..... **73/178 H**  
 [58] **Field of Search** ..... 73/170.02, 170.11, 73/178 H, 180, 181, 182, 183, 204.26, 204.27, 147; 244/17.13, 766, 76 C, 76 R, 90, 179, 184, 186, 194, 195, 75 R; 364/424.06, 922.8

[56] **References Cited**

**U.S. PATENT DOCUMENTS**

2,531,521	11/1950	Link	73/178 H
2,952,154	9/1960	Traksel	73/178 H
2,986,933	6/1961	Summedin et al.	73/178 H
3,070,999	1/1963	Garbell	
3,332,282	7/1967	Daw	73/182

19 Claims, 7 Drawing Sheets

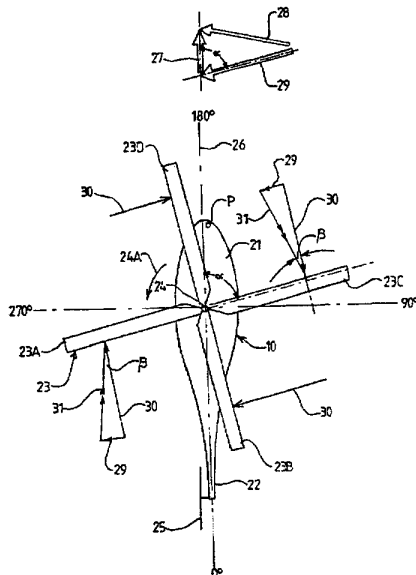

**United States Patent** [19] **4,300,200**  
 Doe Best Available Copy [45] **Nov. 10, 1981**

[54] **HELICOPTER AIRSPEED INDICATING SYSTEM**

[75] Inventor: **Reginald A. Doe**, Yeovil, England

[73] Assignee: **Westland Aircraft Limited**, Yeovil, England

[21] Appl. No.: **96,829**

[22] Filed: **Nov. 23, 1979**

[30] **Foreign Application Priority Data**  
 Dec. 1, 1978 [GB] United Kingdom ..... 46895/78

[51] Int. Cl.<sup>3</sup> ..... **G06F 15/20**

[52] U.S. Cl. .... **364/565; 364/431; 244/17.13; 73/509**

[58] **Field of Search** ..... **364/565, 567, 431, 432, 364/433, 426; 244/17.13; 73/509, 510, 530**

[56] **References Cited**  
**U.S. PATENT DOCUMENTS**

3,761,693	9/1973	Fleury	364/424 X
3,927,306	12/1975	Miller	244/17.13 X
3,963,372	6/1976	McLain et al.	364/431 X
3,969,890	7/1976	Nelson	364/431 X
4,156,912	5/1979	Shigeta et al.	364/715 X
4,236,212	11/1980	Arents	364/431 X

*Primary Examiner*—Edward J. Wise  
*Attorney, Agent, or Firm*—Larson and Taylor

[57] **ABSTRACT**

This invention provides a helicopter airspeed indicating system for providing an indication of a theoretical airspeed of a helicopter in which it is fitted. The airspeed is calculated using measured weight and power values and a known relationship between power, weight and airspeed characteristics of the helicopter, and is particularly useful for providing an indication of helicopter airspeed at the low end of an overall speed range.

**11 Claims, 2 Drawing Figures**

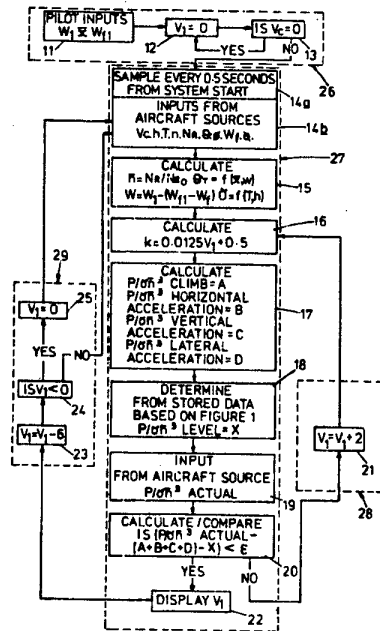



US005214596A

**United States Patent** [19]  
Müller

[11] **Patent Number:** 5,214,596  
[45] **Date of Patent:** May 25, 1993

- [54] **SYSTEM FOR DETERMINING THE AIRSPEED OF HELICOPTERS**
- [75] **Inventor:** H. Burkhard Müller, Frankfurt am Main, Fed. Rep. of Germany
- [73] **Assignee:** Deutsche Forschungs- und Versuchsanstalt für Luft- und Raumfahrt e.V., Fed. Rep. of Germany
- [21] **Appl. No.:** 840,611
- [22] **Filed:** Feb. 20, 1992

**Related U.S. Application Data**

- [63] Continuation of Ser. No. 696,300, Apr. 29, 1991, abandoned, which is a continuation of Ser. No. 523,171, May 14, 1990, abandoned, which is a continuation of Ser. No. 406,856, Sep. 13, 1989, abandoned, which is a continuation of Ser. No. 286,370, Dec. 19, 1988, abandoned, which is a continuation of Ser. No. 62,770, Jun. 15, 1987, abandoned.

**Foreign Application Priority Data**

- [30] Jun. 14, 1986 [DE] Fed. Rep. of Germany ..... 3620177
- [51] **Int. Cl.<sup>5</sup>** ..... **G06F 15/50**
- [52] **U.S. Cl.** ..... 364/565; 364/150; 364/434; 244/17.13
- [58] **Field of Search** ..... 364/150, 151, 149, 433, 364/434; 244/17.13, 17.17

**References Cited**

**U.S. PATENT DOCUMENTS**

4,023,409	5/1977	Durand	73/178
4,092,716	5/1978	Berg et al.	364/150
4,300,200	11/1981	Doc	364/565
4,355,358	10/1982	Cleford et al.	364/150
4,382,283	5/1983	Cleford et al.	354/434
4,567,564	1/1986	Bittner et al.	364/434

**OTHER PUBLICATIONS**

Rainer Schwäble, "Versuche in der BO 105 zur Messung der Fahrt und des Windes" Litton Technische Werks, no date.  
Evaluation of the Helicopter Low Airspeed System Lassie, by J. Kaletka, Deutsche Forschungs- und Ver-

suchsanstalt für Luft- und Raumfahrt e.V., Germany, no date.  
Flight Evaluation Pacer Systems Low-Range Airspeed System LORAS 1000. U.S. Army Aviation Engineering Flight Activity, California. May 1977.  
A New Internal Low Airspeed System for Helicopters, by J. Mandie. Aerospace Division Crouzet, France. May 20, 1985.  
A Method of Helicopter Low Airspeed Estimation based on Measurement of Control Parameters, by A. J. Faulkner et al. Messerschmitt-Bölkow-Blohm GmbH, Germany. Sep. 1979.  
Flight Investigations of a Helicopter Low Airspeed Estimation System Based on Measurement of Control Parameters, by A. J. Faulkner et al. Messerschmitt-Bölkow-Blohm GmbH, Germany. Sep. 1980.

*Primary Examiner*—Thomas G. Black  
*Attorney, Agent, or Firm*—Salter, Michaelson & Benson

[57] **ABSTRACT**

System for determining the airspeed of helicopters, having a coupled measuring device to which is supplied by the cyclic and collective control signals, the attitude angles and the rotational velocities about the axes of the helicopter. The measuring device contains two models, namely a first model of the input behaviour of the helicopter motion, on which the cyclic and collective control signals act as input, and a second model of the system behaviour of the helicopter, on which the condition parameters act as input parameters. The estimated state parameters are obtained in an integration stage by integration of the algebraic sum of the outputs of the two models and the output signal of the correction arrangement, from which the values of the the velocity components are supplied to an indication. The integration stage is connected in front of a correction arrangement for the measured parameters of the rotational velocity and the attitude angle. There is further provided an arrangement for the compensation of steady state model errors.

8 Claims, 5 Drawing Sheets

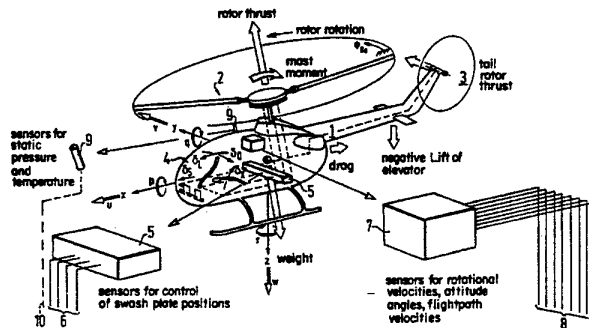

**United States Patent** [19]

Arethens et al.

[11] **Patent Number:** 5,063,777

[45] **Date of Patent:** Nov. 12, 1991

[54] **METHOD AND DEVICE FOR DETERMINING THE SPEED OF A HELICOPTER WITH RESPECT TO THE AIR**

[75] **Inventors:** J. P. Arethens; P. Goumier-Beraud, both of Valence, France

[73] **Assignee:** Sextant Avionique, France

[21] **Appl. No.:** 532,331

[22] **Filed:** Jun. 5, 1990

[30] **Foreign Application Priority Data**

Jun. 7, 1989 [FR] France ..... 89 07514

[51] **Int. Cl.:** ..... G01C 21/10

[52] **U.S. Cl.:** ..... 73/178 H; 73/181; 364/424.06; 364/922.8

[58] **Field of Search:** ..... 73/178 H, 181; 364/922.8, 566, 424.06, 434, 435; 244/17.13

[56] **References Cited**

**U.S. PATENT DOCUMENTS**

4,702,106 10/1987 Hassenpflug et al. .... 73/181  
 4,766,767 8/1988 Hassenpflug et al. .... 73/178 H  
 4,794,793 1/1989 Favre et al. .... 73/181

**FOREIGN PATENT DOCUMENTS**

0283626 5/1987 European Pat. Off. .

0249848 6/1987 European Pat. Off. .  
 0280599 2/1988 European Pat. Off. .  
 2613078 3/1987 France .

*Primary Examiner*—Donald O. Woodie!  
*Attorney, Agent, or Firm*—Lowe, Price, LeBlanc and Becker

[57] **ABSTRACT**

A method and device are disclosed for determining the airspeed of a helicopter, in which, for a plurality of flight configurations of a calibration flight, magnitudes for estimating the airspeed and the collective  $P_0$  and cyclic pitches  $P_x$  and  $P_y$  of the lift rotor, the pitch  $P_z$  of the antitorque rotor, the angles of bank  $\theta_x$  and  $\theta_y$  and the acceleration  $\gamma_z$  are measured. Correlation matrices between the speed estimated with respect to the air and variables related to the pitches, angles and acceleration measured during the calibration flight are then formed. Formulae are derived, for calculating the estimated speed, by a stepwise regression algorithm, which are used in normal flight for calculating, in response to the pitches, angles and acceleration measured during normal flight, the speed with respect to the air, if required after correction of the values of the multiplicative coefficients of these calculation formulae.

13 Claims, 2 Drawing Sheets

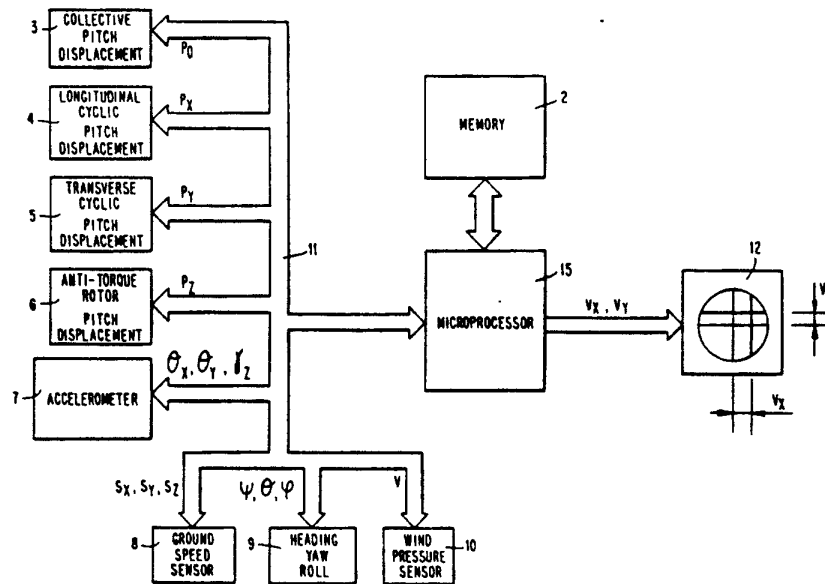

**United States Patent** [19]

Favre et al.

[11] **Patent Number:** 4,794,793

[45] **Date of Patent:** Jan. 3, 1989

[54] **METHOD AND APPARATUS FOR MEASURING THE AIRSPEED OF A HELICOPTER AT LOW SPEED**

[75] **Inventors:** Hélène Favre, Massy; Jean T. Audren, Orsay, both of France

[73] **Assignee:** Societe De Fabrication D'Instruments De Mesure, France

[21] **Appl. No.:** 150,544

[22] **Filed:** Feb. 1, 1988

[30] **Foreign Application Priority Data**

Feb. 4, 1987 [FR] France ..... 87 01367

[51] **Int. Cl.<sup>4</sup>** ..... G01C 21/10

[52] **U.S. Cl.** ..... 73/178 H; 73/181; 364/443

[58] **Field of Search** ..... 73/181, 178 H; 364/443; 244/17.13

[56] **References Cited**

**U.S. PATENT DOCUMENTS**

4,023,409 5/1977 Durand ..... 73/178 H

4,648,269 3/1987 Durand ..... 73/178 H  
4,702,106 10/1987 Hassenpflug et al. .... 73/178 H

*Primary Examiner*—Donald O. Woodiel  
*Attorney, Agent, or Firm*—McCormick, Paulding & Huber

[57] **ABSTRACT**

A helicopter is provided with a lift rotor (Ros), a tail rotor (Rac), first control means for the longitudinal (Pcx) and lateral (Pcy) cyclic pitch of the lift rotor and second control means for the pitch (Pac) of the tail rotor. The parameters such as the longitudinal cyclic pitch (Pax), the lateral cyclic pitch (Pcy), the longitudinal acceleration (Vx) and the acceleration of the helicopter (Vy) as well as the collective pitch (Pcol) of the lift rotor (Ros) and the pitch of the tail rotor (Rac) are measured. The longitudinal (Vax) and lateral (Vay) speed of the helicopter with respect to the air are determined from a biunivocal function of the measured values, particularly in linear combination.

**14 Claims, 4 Drawing Sheets**

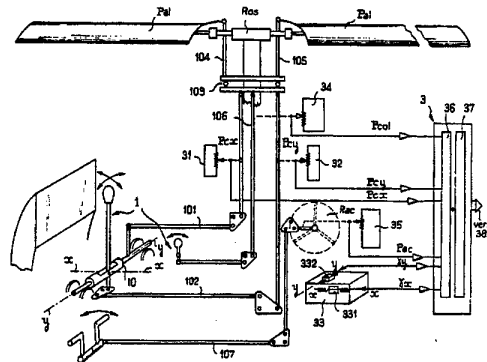



DISTRIBUTION LIST

Low Airspeed Measuring Devices for Helicopter Usage Monitoring Systems

C. G. Knight

AUSTRALIA

DEFENCE ORGANISATION

Task Sponsor

Directorate General Technical Airworthiness - Rotary Wing Section 1

S&T Program

Chief Defence Scientist	}	shared copy
FAS Science Policy		
AS Science Corporate Management		
Director General Science Policy Development		
Counsellor Defence Science, London		Doc Data Sheet
Counsellor Defence Science, Washington		Doc Data Sheet
Scientific Adviser to MRDC Thailand		Doc Data Sheet
Navy Scientific Adviser		Doc Data Sheet & Dist List
Scientific Adviser - Army		1

Platforms Sciences Laboratory

Chief of Air Vehicles Division	Doc Data Sheet & Dist List
Research Leader Propulsion (S. Fisher)	Doc Data Sheet & Dist List
Head Helicopter Life Assessment (A Wong)	1
Task Manager (R Boykett)	1
Author: C Knight	1
G. F. Forsyth	1
D Lombardo	1
S. Gan	1
S Dutton	1

DSTO Library and Archives

Library Fishermans Bend	1
Library Edinburgh	1
Australian Archives	1

Office of the Chief Information Officer

Director General Command, Control, Communications and Computers (DGC4)	Doc Data Sheet
Chief Information Officer	Doc Data Sheet
Deputy CIO	Doc Data Sheet
Director General Information Policy and Plans	Doc Data Sheet
AS Information Structures and Futures	Doc Data Sheet
AS Information Architecture and Management	Doc Data Sheet
Director General Australian Defence Information Office	Doc Data Sheet
Director General Australian Defence Simulation Office	Doc Data Sheet

**Defence Libraries**

Library Manager, DLS-Canberra 1  
Library Manager, DLS - Sydney West Doc Data Sheet

**UNIVERSITIES AND COLLEGES**

Australian Defence Force Academy  
Library 1  
Head of Aerospace and Mechanical Engineering 1  
Hargrave Library, Monash University Doc Data Sheet  
Librarian, Flinders University 1

**OTHER ORGANISATIONS**

National Library of Australia 1  
NASA (Canberra) 1  
AusInfo 1

**OUTSIDE AUSTRALIA**

**INTERNATIONAL DEFENCE INFORMATION CENTRES**

US Defense Technical Information Center 2  
UK Defence Research Information Centre 2  
Canada Defence Scientific Information Service 1  
NZ Defence Information Centre 1

**ABSTRACTING AND INFORMATION ORGANISATIONS**

Engineering Societies Library, US 1  
Documents Librarian, The Center for Research Libraries, US 1

SPARES 5

**Total number of copies: 33**

