

**FINAL REPORT
SEPTEMBER 2003**

REPORT NO. 03-12

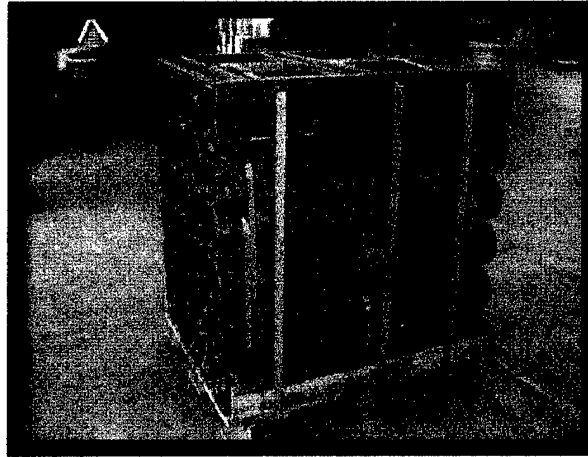

**PA116/171 CONTAINERS ON A WOOD PALLET
WITH METAL TOP ADAPTER, MIL-STD-1660,
FIRST ARTICLE TESTS**

Prepared for:
U.S. Army Defense Ammunition Center
ATTN: SJMAC-DET
1 C Tree Road, Bldg 35
McAlester, OK 74501-9053

Distribution Unlimited



**VALIDATION ENGINEERING DIVISION
MCALESTER, OKLAHOMA 74501-9053**

20031003 142

AVAILABILITY NOTICE

A copy of this report will be furnished each attendee on automatic distribution. Additional copies or authority for reprinting may be obtained by written request from:

Director
U.S. Army Defense Ammunition Center
ATTN: SJMAC-DEV
1 C Tree Road, Bldg. 35
McAlester, OK 74501-9053

Reports may also be downloaded or viewed in PDF format from our web site at:

<http://www.dac.army.mil/DEV/TestReports>

DISTRIBUTION INSTRUCTIONS

Destroy this report when no longer needed. Do not return.

Citation of trade names in this report does not constitute an official endorsement.

The information contained herein will not be used for advertising purposes.

**REPORT NO. 03-12
PA116/171 CONTAINERS ON A WOOD PALLET
WITH METAL TOP ADAPTER, MIL-STD-1660,
FIRST ARTICLE TESTS**

September 2003

ABSTRACT

The U.S. Army Defense Ammunition Center (DAC), Validation Engineering Division (SJMAC-DEV) conducted First Article Tests per MIL-STD-1660, "Design Criteria for Ammunition Unit Loads" on the PA116/171 containers on a wood pallet with metal top adapter provided by Alliant Tech Ordnance and Ground Systems LLC of Plymouth, MN. Two separate containers were tested with total weights of 2,470 lbs each. The tests accomplished on the test units were the stacking, repetitive shock, edgewise-rotational drop, incline impact, forklift handling, sling compatibility, and disassembly tests. The test units passed all required tests. There were four different configurations for this pallet that are different than the typical pallets used for the PA116 container pallets used in the past. 1) The addition of the truss plates decreased the damage to the pallet posts during testing. 2) The smaller plywood board that normally is on the PA116 Container pallet was removed with no ill effects. 3) Roofing nails were used in lieu of staples to secure the banding to the sideboards and performed satisfactory. 4) PA171 containers were loaded on a wooden pallet with minimal problems encountered. It should be noted that the panel screws for the PA171 container did dig into the top deck of the pallet, and though it is a minor note for the pallet, it may be an area of concern for the container holding a seal.

As a result of the performance of the test units, the PA116/171 containers on a wood pallet with metal top adapter provided by Alliant Tech Ordnance and Ground Systems LLC of Plymouth, MN, is recommended for use by the United States Army.

Prepared by:

Reviewed by:



JEFFERY L. DUGAN
Validation Engineer

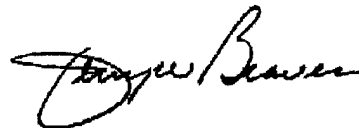

JERRY W. BEAVER
Chief, Validation Engineering Division

U.S. ARMY DEFENSE AMMUNITION CENTER

**VALIDATION ENGINEERING DIVISION
MCALESTER, OK 74501-9053**

REPORT NO. 03-12

**PA116/171 CONTAINERS ON A WOOD PALLET
WITH METAL TOP ADAPTER, MIL-STD-1660,
FIRST ARTICLE TESTS**

TABLE OF CONTENTS

PART	PAGE NO.
1. INTRODUCTION	1-1
A. BACKGROUND	1-1
B. AUTHORITY	1-1
C. OBJECTIVE	1-1
D. CONCLUSION	1-1
2. ATTENDEES	2-1
3. TEST PROCEDURES	3-1
4. TEST EQUIPMENT	4-1
5. TEST RESULTS	5-1
6. DRAWINGS.....	6-1

PART 1 – INTRODUCTION

A. BACKGROUND. The U.S. Army Defense Ammunition Center (DAC), Validation Engineering Division (SJMAG-DEV) conducted First Article Tests per MIL-STD-1660, "Design Criteria for Ammunition Unit Loads" on the PA116/171 containers on a wood pallet with metal top adapter provided by Alliant Tech Ordnance and Ground Systems LLC of Plymouth, MN. Two separate containers were tested with total weights of 2,470 lbs each. The tests accomplished on the test units were the stacking, repetitive shock, edgewise-rotational drop, incline impact, forklift handling, sling compatibility, and disassembly tests. The unitization procedures (See Part 6) were provided by DAC, Transportation Engineering Division (SJMAG-DET).

B. AUTHORITY. This test was conducted IAW mission responsibilities delegated by the U.S. Army Joint Munitions Command (JMC), Rock Island, IL. Reference is made to the following:

1. AR 740-1, 15 June 2001, Storage and Supply Activity Operation
2. OSC-R, 10-23, Mission and Major Functions of U.S. Army Defense Ammunition Center (DAC) 21 Nov 2000.

C. OBJECTIVE. The objective of the tests was to determine if the PA116/171 containers on a wood pallet with metal top adapter met MIL-STD-1660 test requirements prior to the acceptance of the unitization procedures by the U.S. Army.

D. CONCLUSION. The test units passed all required tests. There were four different configurations for this pallet that are different than the typical pallets used for the PA116 container pallets used in the past. 1) The addition of the truss plates decreased the damage to the pallet posts during testing. 2) The smaller plywood board that normally is on the PA116 container pallet was removed with no ill effects. 3) Roofing nails were used in lieu of staples to

secure the banding to the sideboards and performed satisfactorily. 4) PA171 containers were loaded on a wooden pallet with minimal problems encountered. It should be noted that the panel screws for the PA171 container did dig into the top deck of the pallet, and though it is a minor note for the pallet, it may be an area of concern for the container holding a seal.

As a result of the performance of the test units, the PA116/171 containers on a wood pallet with metal top adapter provided by Alliant Tech Ordnance and Ground Systems LLC of Plymouth, MN, is recommended for use by the United States Army.

PART 2 - ATTENDEES

DATE PERFORMED:

Test Unit #1- 13 August 2003

Test Unit #2- 14 August 2003

ATTENDEES

MAILING ADDRESS

Jeffery L. Dugan
General Engineer
DSN 956-8090
(918) 420-8090

Director
U.S. Army Defense Ammunition Center
ATTN: SJMAC-DEV
1 C Tree Road, Bldg. 35
McAlester, OK 74501-9053

Michael Bartosiak
Engineer
DSN 956-8083
(918) 420-8083

Director
U.S. Army Defense Ammunition Center
ATTN: SJMAC-DET
1 C Tree Road, Bldg. 35
McAlester, OK 74501-9053

Jack Reider
Sr. Principal Product Engineer
120mm Tank Ammunition
(763)744-5678

ATK Ordnance and Ground Systems LLC
MN07-LW54
4700 Nathan Lane
Plymouth, MN 55442-2512

PART 3 - TEST PROCEDURES

The test procedures outlined in this section were extracted from the MIL-STD-1660, "Design Criteria for Ammunition Unit Loads," 8 April 1977. This standard identifies steps that a unitized load must undergo if it is to be considered acceptable. The seven tests normally conducted on the test specimen are summarized below.

A. STACKING TEST. The specimen will be tested to simulate a stack of identical items stacked 16 feet high, for a period of one hour. This stacking load will be simulated by subjecting the unit load to a compression weight equal to an equivalent 16-foot stacking height. Photo 1 below shows an example of a unit load in the compression tester.

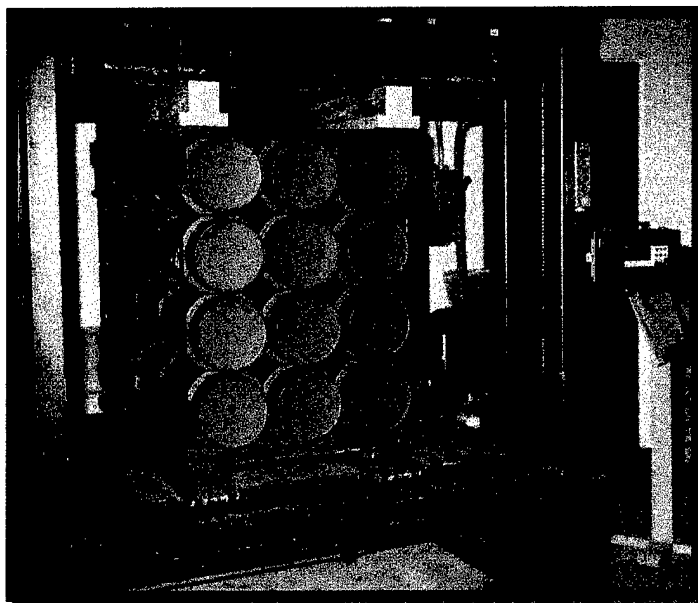

**Photo 1. Example of Compression Tester.
(2.75-inch Hydra 70, PA151 Rocket Pallet in the compression tester.)**

B. REPETITIVE SHOCK TEST. The repetitive shock test is conducted IAW Method 5019, Federal Standard 101. The test procedure is as follows: The test specimen will be placed on (not fastened to) the platform. With the load in one position, the platform will be vibrated at 1/2-inch amplitude (1-inch double amplitude) starting at a frequency of approximately 3 cycles-per-second. The frequency will be steadily increased until the package leaves the platform. The resonant frequency is achieved when a 1/16-inch-thick feeler gage momentarily slid freely between every point on the specimen in contact with the platform at some instance during the cycle. Midway into the testing period, the specimen will be rotated 90 degrees, and the test continued for the duration. Unless failure occurred, the total time of vibration will be three hours. Photo 2 shows an example of the repetitive shock test.

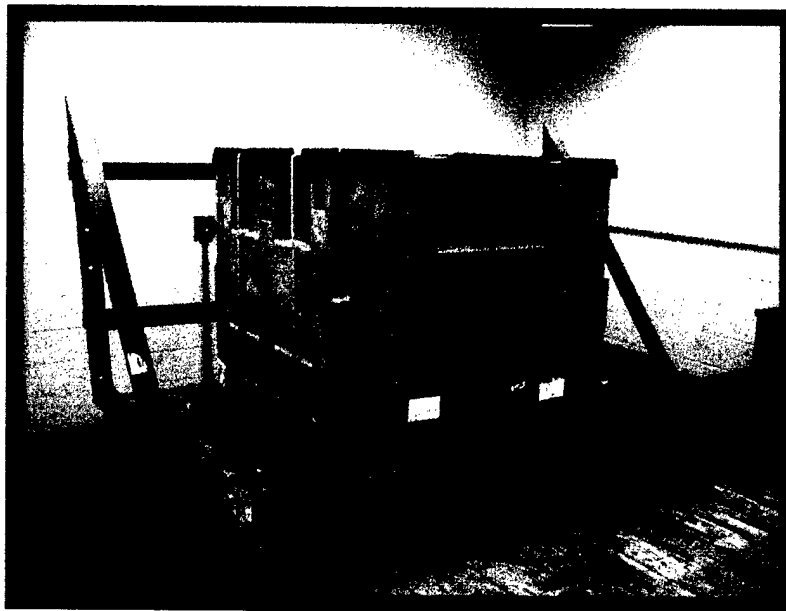
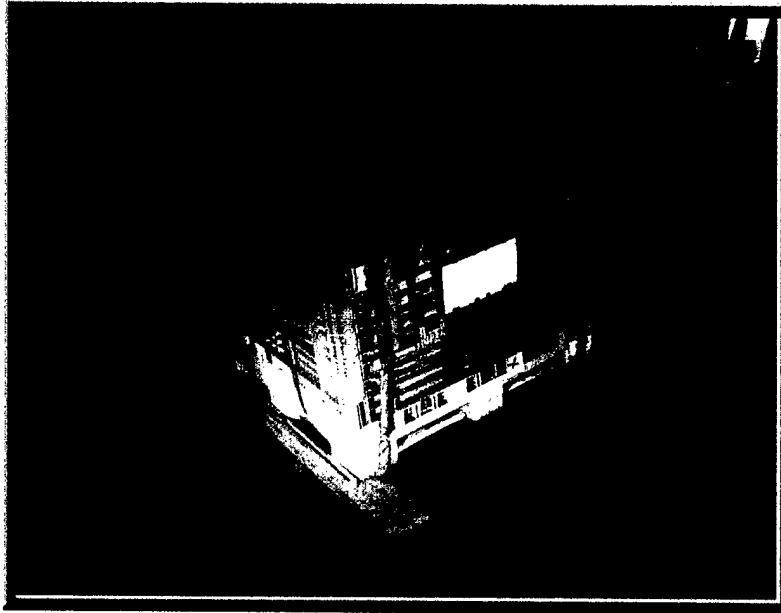

**Photo 2. Example of the Repetitive Shock Test.
(Plastic Gemini Pallet Box)**

C. EDGEWISE ROTATIONAL DROP TEST. This test is conducted using the procedures of Method 5008, Federal Standard 101. The procedure for the

edgewise rotational drop test is as follows: The specimen will be placed on its skids with one end of the pallet supported on a beam 6 inches high. The height of the beam will be increased as necessary to ensure that there is no support for the skids between the ends of the specimen when dropping takes place, but was not high enough to cause the specimen to slide on the supports when the dropped end is raised for the drop. The unsupported end of the specimen is then raised and allowed to fall freely to the concrete, pavement, or similar unyielding surface from a prescribed height. Unless otherwise specified, the height of drop for level A protection conforms to the following tabulation:

GROSS WEIGHT (WITHIN RANGE LIMITS) (Pounds)	DIMENSIONS OF ANY EDGE, HEIGHT OR WIDTH (WITHIN RANGE LIMITS) (Inches)	HEIGHT OF DROPS ON EDGES	
		Level A (Inches)	Level B (Inches)
150-250	60-66	36	27
250-400	66-72	32	24
400-600	72-80	28	21
600-1,000	80-95	24	18
1,000-1,500	95-114	20	16
1,500-2,000	114-144	17	14
2,000-3,000	Above 145- No limited	15	12
Above – 3,000		12	9



**Photo 3. Example of Edgewise Rotational Drop Test
(Plastic XYTEC 4845 Pallet Box)**

D. INCLINE-IMPACT TEST. This test is conducted by using the procedure of Method 5023, Incline-Impact Test of Federal Standard 101. The procedure for the incline-impact test is as follows: The specimen is placed on the carriage with the surface or edge to be impacted projecting at least 2 inches beyond the front end of the carriage. The carriage will be brought to a predetermined position on the incline and released. If it were desired to concentrate the impact on any particular position on the container, a 4- x 4-inch timber may be attached to the bumper in the desired position before the test. The carriage struck no part of the timber. The position of the container on the carriage and the sequence in which surfaces and edges were subjected to impacts may be at the option of the testing activity and dependent upon the objective of the test. When the test is to determine satisfactory requirements for a container or pack, and, unless otherwise specified, the specimen will be subjected to one impact on each surface that has each dimension less than 9.5 feet. Unless otherwise specified, the velocity at the time of the impact was 7 feet-per-second. Photo 4 shows an example of this test.

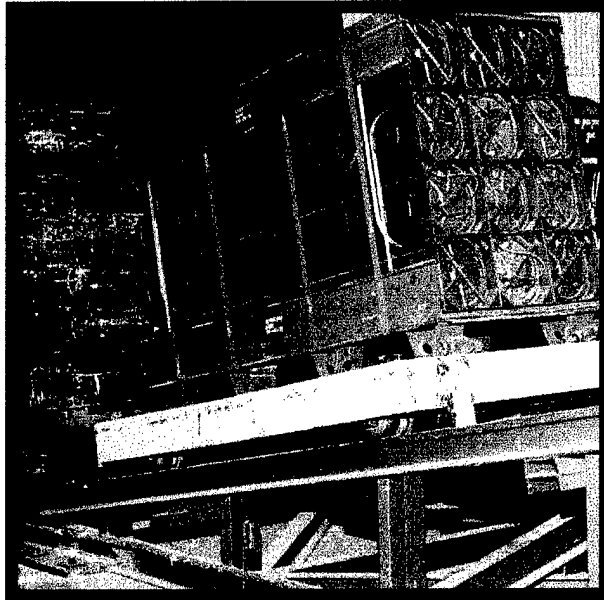

**Photo 4. Example of the Incline-Impact Test.
(2.75-Inch, Hydra 70, PA151 Rocket Pallet on incline-impact tester.)**

E. FORKLIFTING TESTS. The specimen will be lifted clear of the ground by a forklift from the end of the specimen and transported on the forks in the level or back-tilt position. The forklift will pass over the Optional Rough Handling Course For Forklift Trucks as outlined in MIL-STD-1660. The course will consist of parallel pairs of 1-inch boards spaced 54 inches apart and will be laid flat wise on the pavement across the path of the forklift. One pair will be laid at an angle of approximately 60 degrees to the path so that the left wheel strikes first. Another pair will be laid securely across the path of the forklift so that the wheels strike simultaneously. Another pair will be laid at an angle of approximately 75 degrees to the path so that the right wheel strikes first. The specimen will be transported over the Optional Rough Handling Course. The specimen shall be observed for deflection and damage. The specimen will be rotated 90 degrees and the specimen lifted from the side and the above steps repeated.

F. SLING COMPATIBILITY TEST. The specimen utilizing special design or non-standard pallets will be lifted, swung, lowered and otherwise handled as necessary, using slings of the types normally used for handling the unit loads under consideration. Slings will be easily attached and removed. Danger of slippage or disengagement when load is suspended will be cause for rejection of the specimen.

G. DISASSEMBLY TEST. Following all rough handling tests the specimen may be squared up within 2 inches of its original shape and on a flat level surface. The strapping will then be cut and removed from the palletized load. Assembly of the load will be such that it retains its unity upon removal of the strapping.

PART 4 - TEST EQUIPMENT

A. COMPRESSION TESTER.

1. Nomenclature	Compression Table
2. Manufacturer:	Ormond Manufacturing
3. Platform:	60- by 60-inches
4. Compression Limit:	50,000 pounds
5. Tension Limit:	50,000 pounds

B. TRANSPORTATION (REPETITIVE SHOCK) SIMULATOR.

1. Nomenclature	Repetitive Shock Simulator
2. Manufacturer:	Gaynes Laboratory
3. Capacity:	6,000-pound payload
4. Displacement:	1/2-inch amplitude
5. Speed:	50 to 400 RPM
5. Platform:	5- by 8-foot

C. INCLINED PLANE.

1. Nomenclature	Incline Plane Impact Tester
2. Manufacturer:	Conbur Incline
3. Type:	Impact Tester
4. Grade:	10 percent incline
5. Length:	12-foot

PART 5 - TEST RESULTS

A. CONTAINER DATA. The test units were inertly loaded to the specified design weight. The test specimen was prepared using the unitization procedures specified in Part 6 – Drawings. Special care was taken to ensure that each individual interior ammunition container had the proper amount of weight in order to achieve a realistic pallet center of gravity (CG). Once properly prepared, the test unit was tested using MIL-STD-1660, "Design Criteria for Ammunition Unit Loads," requirements.

TEST UNIT #1:

Test Date: 13 August 2003

Weight: 2,470 pounds

Length: 44-1/2 inches

Width: 40-1/8 inches

Height: 52-5/8 inches

Container Inertly loaded with:

25 PA116 containers each at 76 lbs and 5 PA171 containers at 76 lbs loaded with sand. The PA171 containers were located on the bottom layer.

TEST UNIT #2:

Test Date: 14 August 2003

Weight: 2,470 pounds

Length: 44-1/2 inches

Width: 40-1/8 inches

Height: 52-5/8 inches

Container Inertly loaded with:

25 PA116 Containers each at 76 lbs and 5 PA171 Containers at 76 lbs loaded with sand. The PA171 containers were located on the bottom layer.

B. TEST RESULTS - TEST UNIT #1:

1. STACKING TEST. Test Unit #1 was compressed with a load force of 7,410 pounds for 60 minutes on 13 August 2003. There was no damage noted to the test unit as a result of this test. See Photo 5 below for a typical picture of the test unit in the compression tester.

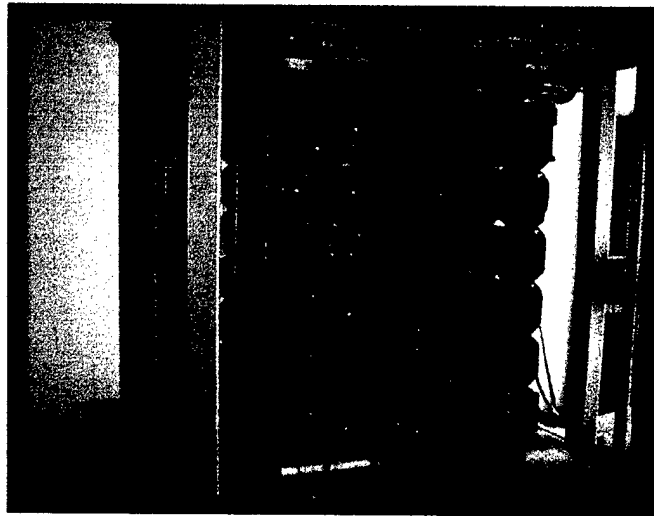

Photo 5. Test Setup for Compression Testing.

2. REPETITIVE SHOCK TEST. Test Unit #1 was vibrated 90 minutes at 165 RPM in the longitudinal orientation and 90 minutes at 160 RPM in the lateral orientation on 13 August 2003. There was minor damage to the truss-plate due to sliding the test unit across the vibration table. See Photo 6 for the test setup for the vibration test and see Photo 7 for the minor damage to the truss-plate. The truss-plate should be attached a minimum of 1/8" from the bottom of the pallet to correct this minor problem in the future.

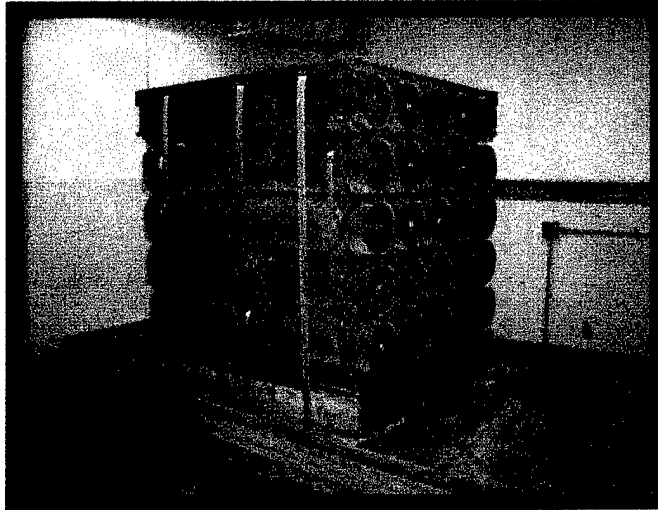

Photo 6. Test Setup for Repetitive Shock Tests.

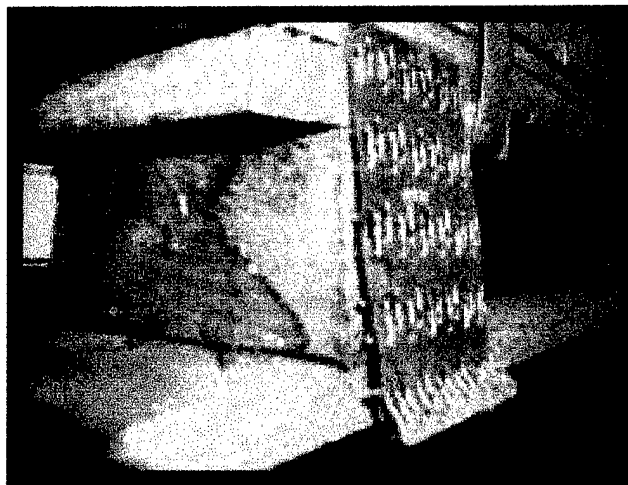

Photo 7. Minor Damage Sustained During Repetitive Shock Tests.

3. EDGEWISE ROTATIONAL DROP TEST. Test Unit #1 was edgewise rotationally dropped from a height of 15 inches on both longitudinal sides and both lateral sides. No damage was noted from this test. See Photo 8 for the test setup for the edgewise rotational drop tests.



Photo 8. Test Setup for Edgewise Rotational Drop Testing.

4. INCLINE-IMPACT TEST. Test Unit #1 was incline-impacted on all four sides with the pallet impacting the stationary wall from a distance of 8 feet. No additional problems were encountered. See Photo 9 for test setup for incline-impact testing.

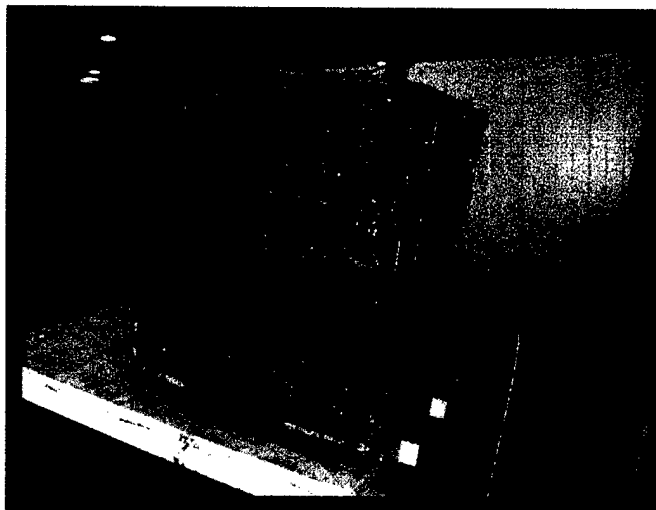

Photo 9. Test Setup for Incline-Impact Testing.

5. FORKLIFTING TEST. Test Unit #1 was lifted from the end of the pallet on the forks of the forklift truck and carried over the hazard course three times with no damage nor instability noted. The test unit was lifted from the opposite

end of the pallet and the above steps accomplished with no problems encountered. See Photo 10 for the test setup during the forklifting test.

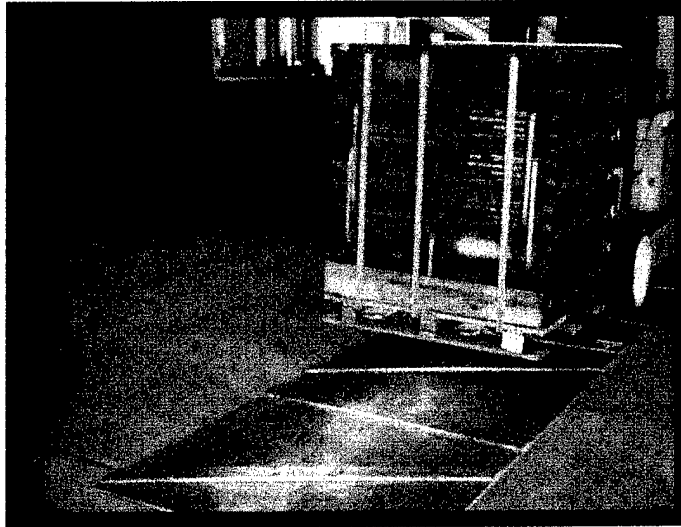

Photo 10. Test Setup for Forklifting Testing.

6. SLING COMPATIBILITY TEST. The test unit was sling tested using 4 lifting rings, 3 lifting rings, and 2 lifting rings with no additional problems were noted. See photo 11 for the test setup during sling compatibility testing.

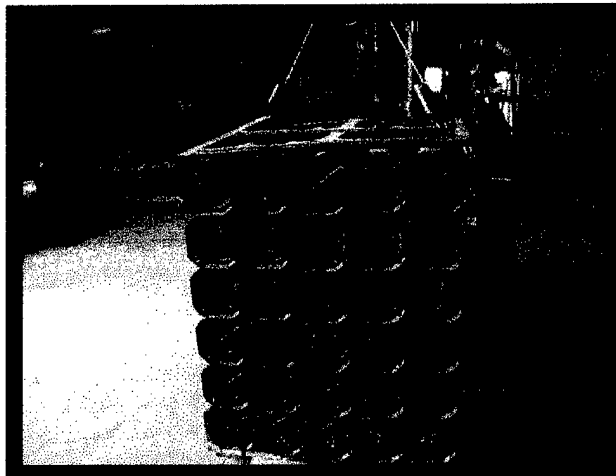

Photo 11. Test Setup for Sling Compatibility Testing.

7. DISASSEMBLY TEST. During the disassembly of Test Unit #1 minor damage was noted where the panel screws for the PA171 container dug into the top deck of the pallet, and though it is a minor note for the pallet, it may be an area of concern for the container holding a seal. See Photo 12 for an example of the damage was causing to the pallet deck. Also, the nails holding the banding in place appeared to work satisfactory. See Photo 13 for an example on how the nails secured the banding to the buffer board.



Photo 12. Damage to Top Deck from Panel Screws on the PA171.

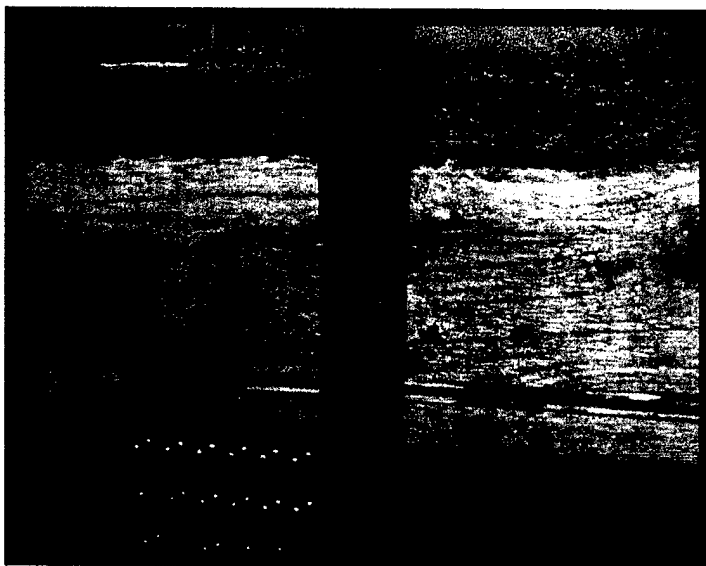

Photo 13. Nails Securing Banding to Side Buffer Board.

8. **CONCLUSION**. Test Unit #1 passed all required tests.

C. **TEST RESULTS - TEST UNIT #2:**

1. **STACKING TEST**. Test Unit #2 was compressed with a load force of 7,410 pounds for 60 minutes on 14 August 2003. No damage was noted as a result of this test.

2. **REPETITIVE SHOCK TEST**. Test Unit #2 was vibrated 90 minutes at 165 RPM in the longitudinal orientation and 160 RPM in the lateral orientation. No damage was noted as a result of this test. It should be noted that the truss-plate was placed 1/8" from the bottom of the pallet.

3. **EDGEWISE ROTATIONAL DROP TEST**. Test Unit #2 was edgewise rotationally dropped from a height of 15 inches on both longitudinal sides and both lateral sides. No damage was noted from this test.

4. **INCLINE-IMPACT TEST**. Test Unit #2 was incline-impacted on all four sides with the pallet impacting the stationary wall from a distance of 8 feet. No additional problems were encountered.

5. **FORKLIFTING TEST**. Test Unit #2 was lifted from the end of the pallet on the forks of the forklift truck and carried over the hazard course three times with no damage or instability noted. The test unit was lifted from the opposite end of the pallet and the above steps accomplished with no problems encountered.

6. **SLING COMPATIBILITY TEST**. The test unit was sling tested using 4 lifting rings, 3 lifting rings, and 2 lifting rings with no additional problems were noted.

7. **DISASSEMBLY TEST.** During the disassembly of Test Unit #2 no additional problems were noted, other than the same minor damage noted during testing of Test Unit #1.

8. **CONCLUSION.** Test Unit #2 passed all required tests.

PART 6- DRAWINGS

:
The following test sketches represent the load configurations that were
:
subjected to the test criteria.

MIL-STD-1660 TESTING OF THE UNITIZATION OF PA116/PA171 CONTAINERS ON A WOOD PALLET WITH METAL TOP ADAPTER SKETCH

**THIS THREE PAGE DOCUMENT DEPICTS PROCEDURES FOR UNITIZING
PA116/PA171 CONTAINERS FOR MIL-STD 1660 TESTING.**

**Prepared during June 2003 by:
U.S. Army Defense Ammunition Center
ATTN: SJMAC-DET
McAlester, OK 74501
POC: Mike Bartosiak
DSN 956-8083
Comm (918) 420-8083
Fax 956-8811
E-mail: michael.bartosiak@dac.army.mil**

**Laura Fieffer
Acting Chief, Transportation Engineering Division**

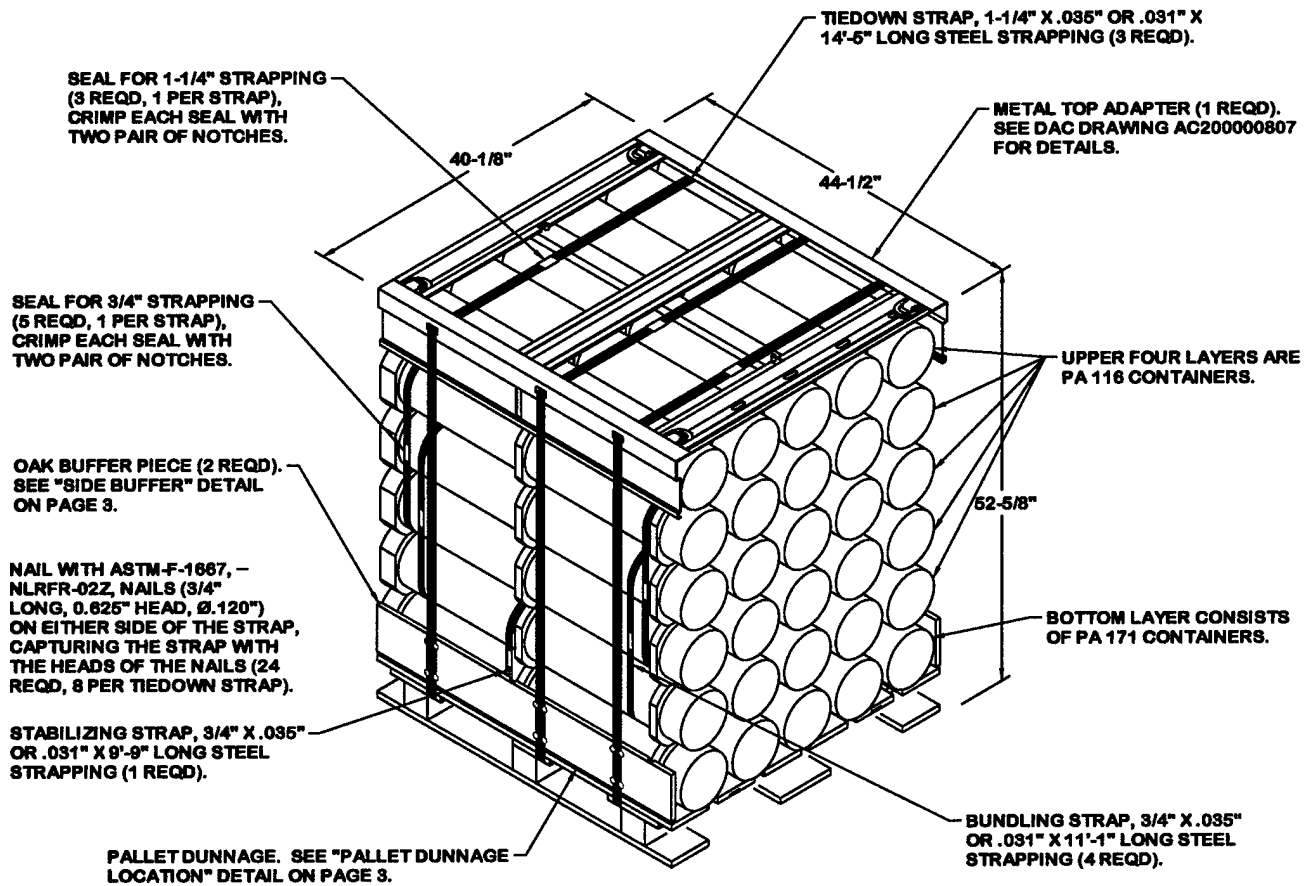

PA116/PA171 TEST LOAD

BILL OF MATERIAL		
NAILS	NO. REQD	POUNDS
NLRF-02Z 6d (2")	24 6	0.14 0.04
SPECIAL PALLET, 40" X 44"	1 REQD	77 LBS
STEEL STRAPPING, 3/4"	54.08' REQD	4.83 LBS
SEAL FOR 3/4" STRAPPING	5 REQD	NIL
STEEL STRAPPING, 1-1/4"	43.25' REQD	6.55 LBS
SEAL FOR 1-1/4" STRAPPING	3 REQD	NIL
PLYWOOD, 3/8"	5.21 SQ FT REQD	5.37 LBS
OAK, 3/4"	3.67 SQ FT REQD	7.37 LBS
METAL TOP ADAPTER	1 REQD	57 LBS

LOAD AS SHOWN

ITEM	WEIGHT (APPROX)
25 PA 116 CONTAINERS AT 76 LBS	1,900 LBS
5 PA 171 CONTAINERS AT 76 LBS	380 LBS
DUNNAGE	82 LBS
PALLET	77 LBS
TOTAL WEIGHT	2,439 LBS (APPROX)
CUBE	54.4 CU FT (APPROX)

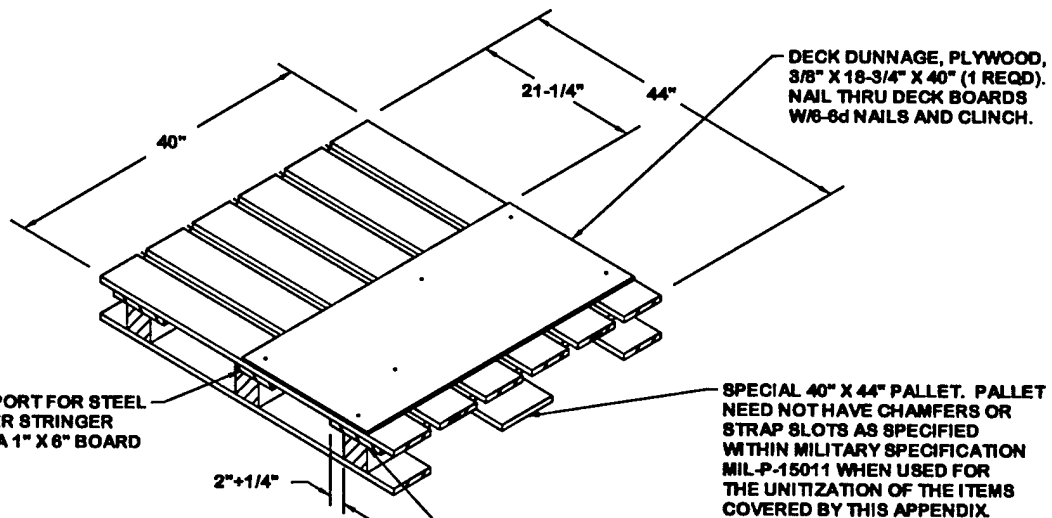

PALLET DUNNAGE LOCATION

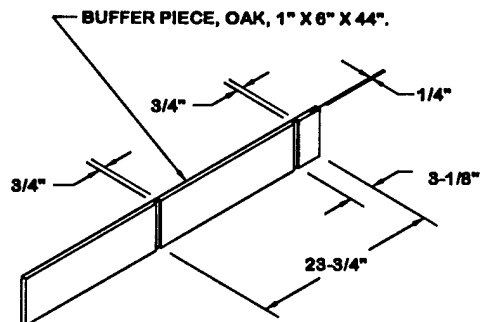

SIDE BUFFER

2 REQD.