

ERDC/GSL TR-03-11

Geotechnical and Structures
Laboratory

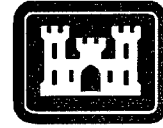

US Army Corps
of Engineers®
Engineer Research and
Development Center

Field Study of Live Load Distribution Factors and Dynamic Load Allowance on Reinforced Concrete T-Beam Bridges

Matthew D. Trimble, Thomas E. Cousins,
and Yazmin Seda-Sanabria

August 2003

20031007 026

Field Study of Live Load Distribution Factors and Dynamic Load Allowance on Reinforced Concrete T-Beam Bridges

Matthew D. Trimble, Thomas E. Cousins

*Virginia Polytechnic Institute and State University
Blacksburg, VA 24061*

Yazmin Seda-Sanabria

*Geotechnical and Structures Laboratory
U.S. Army Engineer Research and Development Center
3909 Halls Ferry Road
Vicksburg, MS 39180-6199*

Final report

Approved for public release; distribution is unlimited

ABSTRACT: This study focuses on the evaluation of live load distribution and dynamic load allowance factors for reinforced concrete T-beam bridges subject to heavy military-vehicle loading. Field displacement measurements on actual bridges were incorporated as part of the evaluation procedure. The vehicle under consideration in this study was a U.S. Army Palletized Loading System (PLS) military vehicle. Results from this evaluation were compared to those obtained from a civilian dump truck owned by the Virginia Department of Transportation (VDOT). The comparative evaluation also considered the design guidelines presented in the American Association of State Highway and Transportation Officials (AASHTO) Standard Specifications for Highways Bridges and the AASHTO Load Resistance Factor Design (LRFD) Bridge Design Specifications.

Two typical cast-in-place reinforced concrete T-beam bridges were selected for field testing with the vehicle under various transverse position scenarios. It was concluded that there was not an appreciable difference in the load distribution factors obtained from the PLS truck and the civilian dump truck. In all instances, the load distribution factor obtained for the PLS truck was smaller than the value specified by the AASHTO Standard Specifications. Results concerning the dynamic load allowance factor for the PLS truck were inconclusive due to the difficulty in controlling the position of the truck over the bridge deck at high speeds. The information derived from this study will contribute in the development of accurate methodologies for the determination of load-carrying capacity of bridges.

DISCLAIMER: The contents of this report are not to be used for advertising, publication, or promotional purposes. Citation of trade names does not constitute an official endorsement or approval of the use of such commercial products. All product names and trademarks cited are the property of their respective owners. The findings of this report are not to be construed as an official Department of the Army position unless so designated by other authorized documents.
DESTROY THIS REPORT WHEN IT IS NO LONGER NEEDED. DO NOT RETURN TO THE ORIGINATOR.

Contents

Conversion Factors, Non-SI to SI Units of Measurement.....	vii
Preface.....	viii
1—Introduction and Literature Review.....	1
Introduction.....	1
Literature Review	2
Lateral Live Load Distribution Factor.....	2
Dynamic Load Allowance.....	3
Objectives	4
Franklin County Bridge	4
Patrick County Bridge	6
2—Test Procedure and Data.....	9
Test Procedure, Franklin County Bridge	9
Test Procedure, Patrick County Bridge	12
Sample Data, Franklin County Bridge.....	14
Sample Data, Patrick County Bridge	18
3—Data Analysis and Results	23
Lateral Live Load Distribution Factors.....	23
Distribution Factors, Franklin County Bridge.....	24
Distribution Factors, Patrick County Bridge.....	26
Dynamic Load Allowance	29
Dynamic Load Allowance, Franklin County Bridge	29
Dynamic Load Allowance, Patrick County Bridge	31
4—Discussion, Conclusions, and Recommendations	32
Discussion of Measured Deflections	32
Conclusions.....	33
Lateral Live Load Distribution Factors	33
Dynamic Load Allowance.....	33
Recommendations	34
Lateral Live Load Distribution Factor.....	34
Dynamic Load Allowance.....	34
References	35

Appendix A: Calculation of AASHTO Distribution Factors and Dynamic Load Allowance	A1
Appendix B: Pretest Analysis for Estimation of Deflections	B1
SF 298	

List of Figures

Figure 1. Franklin County Bridge elevation.....	5
Figure 2. Franklin County Bridge Section 1-1	5
Figure 3. Franklin County Bridge	6
Figure 4. Patrick County Bridge elevation.....	7
Figure 5. Patrick County Bridge Section 1-1	7
Figure 6. Patrick County Bridge	8
Figure 7. VDOT dump truck axle spacing and weights (Franklin County Bridge).....	10
Figure 8. PLS Military-Vehicle specifications.....	10
Figure 9. PLS Military-Vehicle axle spacings	11
Figure 10. PLS Military-Vehicle axle weights.....	11
Figure 11. Truck orientations, Franklin County Bridge.....	12
Figure 12. VDOT dump truck axle spacing and weights (Patrick County Bridge).....	13
Figure 13. Truck orientations, Patrick County Bridge	13
Figure 14. Variation of Deflection vs. Time under static loading - dump truck over right exterior girder (Franklin County Bridge).....	16
Figure 15. Maximum Beam Deflection under static loading - dump truck over right exterior girder (Franklin County Bridge)	16
Figure 16. Variation of Deflection vs. Time under static loading – PLS Military-Vehicle over right exterior girder (Franklin County Bridge).....	17
Figure 17. Maximum Beam Deflection under static loading - PLS Military-Vehicle over right exterior girder (Franklin County Bridge).....	17
Figure 18. Comparison of Static and Dynamic Deflections, dump truck over right exterior girder (Franklin County Bridge)	18
Figure 19. Variation of Deflection vs. time under static loading - dump truck centered between interior girders (Patrick County Bridge)	20
Figure 20. Maximum Beam Deflection under static loading - dump truck centered between interior girders (Patrick County Bridge)	21

Figure 21.	Variation of Deflection vs. Time under static loading – PLS Military-Vehicle centered between interior girders (Patrick County Bridge).....	21
Figure 22.	Maximum Beam Deflection under static loading - PLS Military-Vehicle centered between interior girders (Patrick County Bridge).....	22
Figure 23.	Comparison of Static and Dynamic Deflections, dump truck centered between interior girders (Patrick County Bridge).....	22
Figure 24.	Distribution Factors for VDOT dump truck (Franklin County Bridge).....	24
Figure 25.	Distribution Factors for PLS Military-Vehicle (Franklin County Bridge).....	25
Figure 26.	Comparison of Distribution Factors for VDOT Dump Truck and PLS Military-Vehicle (Franklin County Bridge).....	26
Figure 27.	Distribution Factors for VDOT dump truck (Patrick County Bridge).....	27
Figure 28.	Distribution Factors for PLS Military-Vehicle (Patrick County Bridge).....	28
Figure 29.	Comparison of Distribution Factors for VDOT Dump Truck and PLS Military-Vehicle (Patrick County Bridge).....	29
Figure 30.	Dynamic Load Allowance for Franklin County Bridge.....	30
Figure 31.	Dynamic Load Allowance for Franklin County Bridge.....	31

List of Tables

Table 1.	AASHTO Live Load Distribution Factors.....	3
Table 2.	AASHTO Dynamic Load Allowance.....	4
Table 3.	Maximum Beam Deflections, (Franklin County Bridge).....	14
Table 4.	Beam Deflections Under Static Loading (Franklin County Bridge).....	15
Table 5.	Beam Deflections Under Dynamic Loading (Franklin County Bridge).....	15
Table 6.	Maximum Beam Deflections (Patrick County Bridge).....	19
Table 7.	Beam Deflections Under Static Loading (Patrick County Bridge).....	19
Table 8.	Beam Deflections Under Dynamic Loading (Patrick County Bridge).....	20
Table 9.	Comparison of AASHTO and Measured Distribution Factors for VDOT Dump Truck (Franklin County Bridge).....	25

Table 10.	Comparison of AASHTO and Measured Distribution Factors for PLS Military-Vehicle (Franklin County Bridge).....	25
Table 11.	Comparison of AASHTO and Measured Distribution Factors for VDOT Dump Truck (Patrick County Bridge)	27
Table 12.	Comparison of AASHTO and Measured Distribution Factors for PLS Military-Vehicle (Patrick County Bridge)	28
Table 13.	Summary of Dynamic Load Allowances (Franklin County Bridge)	30
Table 14.	Summary of Dynamic Load Allowances (Patrick County Bridge)	31

Conversion Factors, Non-SI to SI Units of Measurement

Non-SI units of measurements used in this report can be converted to SI unit as follows:

Multiply	By	To Obtain
cubic feet	0.028317	cubic meters
fahrenheit degrees	$(f-32) \times (5/9)$	celsius degrees
feet	0.304800	meters
grams	0.001	kilograms
gallons	0.00378	cubic meters
inches	0.025400	meters
inches	25.4	millimeters
miles	1.609	kilometers
ounces	0.00002957	cubic meters
pint	0.00004731	cubic meters
pounds (force) per square inch	0.006894757	megapascals
pounds per cubic foot	16.0	kilograms per cubic meter
square inches	0.000645	square meters

Preface

This report describes a research study developed by the Virginia Polytechnic Institute and State University (Virginia Tech) in collaboration with the U.S. Army Engineer Research and Development Center (ERDC) for the evaluation of live load distribution and dynamic load allowance factors for reinforced concrete T-beam bridges subjected to heavy military-vehicle loadings. The results obtained from this study will be used as part of a load capacity evaluation procedure for reinforced concrete T-beam bridges currently under development. The study was part of the AT40 Direct-Alloted 159T TeleEngineering Development RDT&E Work Package, Work-Unit TE004 "Rapid Load Capacity Assessment of Reinforced Concrete Bridges," which is sponsored by Headquarters, U.S. Army Corps of Engineers.

This publication was prepared by personnel from Virginia Tech and the ERDC, Geotechnical and Structures Laboratory (GSL), Vicksburg, MS. The research described herein was conducted by Mr. Matthew D. Trimble and Prof. Thomas E. Cousins, Virginia Tech, and by Ms. Yazmin Seda-Sanabria, Structural Engineering Branch (StEB), GSL. Ms. Seda-Sanabria prepared this publication under the general supervision of Dr. David W. Pittman, Acting Director, GSL; Dr. Robert L. Hall, Chief, Geosciences & Structures Division, GSL; and Mr. James S. Shore, Chief, StEB, GSL.

At the time of publication of this report, COL James R. Rowan, EN, was Commander and Executive Director of ERDC, and Dr. James R. Houston was Director.

1 Introduction and Literature Review

Introduction

Constructed since the 1930's, cast-in-place concrete T-beam bridges account for a significant portion of the existing bridge super-structures in the United States and other countries. These bridges offer an efficient, lighter self-weight alternative to reinforced concrete slab bridges without sacrificing stiffness. Concrete T-beam bridges were typically selected for spans of approximately 30 to 50 ft¹. Advances in prestressed concrete technology and composite construction have allowed these types of super structures to replace their more massive, labor intensive concrete T-beam counterparts.

In theaters of operation, the United States(U.S.) Army frequently has to determine the load carrying capacity of concrete T-beam bridges. Like any structure, load-rating analysis of a concrete T-beam bridge is contingent on two factors: the capacity of the structure's individual members and the resulting load effects these members are expected to resist. The failure load of a statically determinate structure is reached when the load effect in any member becomes greater than that member's capacity.

The capacity of a T-beam bridge is a function of the geometry and dimensions of the bridge, the amount, placement, and yield strength of tensile and shear reinforcement, and the compressive strength of the concrete. Since the reinforcing steel is usually encased in concrete and in-field methods for determining the compressive strength of concrete are unavailable, obtaining these parameters can be difficult.

The amount of dead load that each T-beam member carries is mainly determined by the geometry and dimensions of the bridge structure (tributary area concept). Dead loads placed on the structure after the deck concrete has cured (such as parapets) are assumed to be equally distributed to each T-beam as prescribed in the American Association of State Highway and Transportation Officials (AASHTO) Standard Specifications. The capacity of an individual T-beam member to carry traffic live load is a function of the lateral live load

¹ A table for converting non-SI units of measurements to SI units is presented on page vii.

distribution factor and the dynamic load allowance, otherwise known as impact factor.

Literature Review

Lateral Live Load Distribution Factor

The lateral live load distribution factor is the fraction of a vehicle axle load that an individual T-beam is expected to carry (Barker and Puckett 1997). Parameters that influence the distribution factor are the spacing of the T-beams and the stiffness of the deck relative to the stiffness of the T-beams. Characteristics of the vehicle such as the axle loads, tire size (contact area), and axle lengths also have a direct impact on the live load distribution factor. In reality, a reinforced concrete T-beam bridge is an orthotropic (different capacities along the two plan dimensions) plate simply supported along two edges and free along the other two edges. The bridge is much stronger in the longitudinal direction due to the presence of the tee stems and the large quantity of longitudinal tension steel. However, there is still appreciable stiffness in the transverse direction from the deck slab and transverse deck reinforcement. If the deck slab was a rigid plate, perfect distribution would occur, assuming the T-beams have relatively equal vertical stiffness. Each T-beam would carry a fraction of the total load on the bridge equal to the total load divided by the number of T-beams in the bridge cross section. If the deck was a membrane (no flexural stiffness) the portion of the total load carried by an individual T-beam could be determined using the principles of statics, assuming the deck to be simply supported between T-beams. This concept is known as the lever rule. An actual bridge deck provides a scenario somewhere between “perfect” distribution and “no” distribution.

There are several methods that can be used to determine the distribution factors for concrete T-beam bridges with varying degrees of accuracy and effort. The distribution factor for a particular beam (interior or exterior) can be calculated assuming the deck slab to act as a simply supported beam between T-beams. Using the lever rule, the truck or trucks are positioned on the deck to generate the largest possible reaction on the T-beam under investigation. Although this procedure is fast and simple, it is very conservative since it assumes the deck is incapable of distributing the load to beams that are not directly adjacent to the loads. Another possibility is to assume that each beam equally shares all of the loads on the bridge. This is an unconservative assumption since the deck is unable to provide “perfect” distribution. Another possibility is to model the bridge using a grillage or grid of beams with representative flexural and torsional properties. Equations of compatibility of slopes and displacements at the beam intersections can be solved to calculate the load distribution (Barker and Puckett 1997). This method provides accurate results, but requires a large amount of computational effort. Investigation of distribution factors using classical plate theory or the finite element method to analyze an orthotropic plate model of the bridge can provide excellent results, but also requires tremendous effort. The accepted procedure for determining transverse live load distribution factors for concrete T-beam bridge design and load rating is outlined in the AASHTO Standard Specification and in the

AASHTO Load Resistance Factor Design (LRFD) Standard Specifications (AASHTO 1996 and AASHTO 1998). AASHTO provides simple and conservative formulas for live load distribution factors for interior and exterior beams. These formulas can be found in Table 1.

Table 1 AASHTO Live Load Distribution Factors	
Interior Beams	
AASHTO Standard Specifications	AASHTO LRFD
One Lane Loaded → S/6.5'	$0.06+(S/14)^{0.4}(S/L)^{0.3}(K_g/12.0Lt_s^3)^{0.1}$
Two Lanes Loaded → S/6.0''	$0.075+(S/9.5)^{0.6}(S/L)^{0.2}(K_g/12.0Lt_s)^{0.1}$
Exterior Beams	
AASHTO Standard Specifications	AASHTO LRFD
One Lane Loaded → Lever Rule	Lever Rule
Two Lanes Loaded → Lever Rule	$g = e_{g^{interior}} ; e = 0.77+d_e/0.91$
* If S>6' use the Lever Rule. ** If S>10' use the Lever Rule. S=beam spacing (feet) L=span length (feet) $K_g=n(I+Ae_g^2)$ n=modular ratio of beam concrete to deck concrete (E_b/E_d) I=gross moment of inertia ($in.^4$) e_g =distance between c.g.'s of deck and concrete T-beam stem (inch) t_s =slab thickness (inch) d_e =distance from outside web of exterior girder to interior face of curb or barrier (feet) A=cross sectional area of T-beam stem ($in.^2$)	

Dynamic Load Allowance

The dynamic load allowance is the percent increase in the load that an individual T-beam is expected to carry due to the fact that vehicle loads are not static. Variables that influence this increase in load are the speed of the vehicle, the stiffness of the vehicle's suspension, the mass and stiffness of the bridge (fundamental frequency), and the condition of the deck surface, deck joints, and approach slabs. As the vehicle suspension oscillates to compensate for roughness in the deck surface, axle forces greater than the vehicle static weight are generated (Barker and Puckett 1997). Because of the number, complexity, and variability of the parameters that influence the dynamic load allowance, it is very difficult to evaluate this quantity analytically. The most reliable method for determining the dynamic load allowance for a particular bridge and vehicle is to perform field testing. AASHTO provides simplified formulas to account for the increase in live load due to dynamic effects (AASHTO 1996 and AASHTO 1998). These formulas can be found in Table 2.

Table 2 AASHTO Dynamic Load Allowance	
AASHTO Standard Specification	AASHTO LRFD
$I=L/(L+125)$	$I=33\%$

L=span length (ft)

Objectives

The purpose of this study is to evaluate (via field testing) two of the most important parameters needed to determine the load carrying capacity of a reinforced concrete T-beam bridge: the lateral live load distribution factor and the dynamic load allowance. Computed values of the live load distribution factor and dynamic load allowance for an U.S. Army Palletized Loading System (PLS) truck will be compared to the values obtained for a civilian dump truck. These quantities will also be compared to those given by the AASHTO Standard Specification and AASHTO LRFD (see Appendix A for AASHTO values). The ultimate goal of the project is to provide the U.S. Army with a highly reliable and fast method to determine if a reinforced concrete T-beam bridge has the capacity to handle a one-time loading of a PLS truck. Determining reasonable values for the live load distribution factor and the dynamic load allowance are vital parts of this effort. Two typical reinforced concrete T-beam bridges in Southwest Virginia were selected for testing.

Franklin County Bridge

The first bridge chosen for testing carries Virginia Route 697 over Mill Creek in Franklin County near the town of Rocky Mount. This three, simple-span bridge was built in 1979, rests on steel bearing pads, and has no skew with the roadway. The plan drawings indicate that the T-beams were constructed of concrete having a 28-day compressive strength of 4,000 psi and Grade 60 (yield strength equal to 60,000 psi) steel reinforcing bars (VDOT 1979). An elevation view of the three-span super structure as well as a section view of the four T-beam cross section can be seen in Figure 1 and Figure 2, respectively. Figure 3 shows an actual view of the Franklin County Bridge.

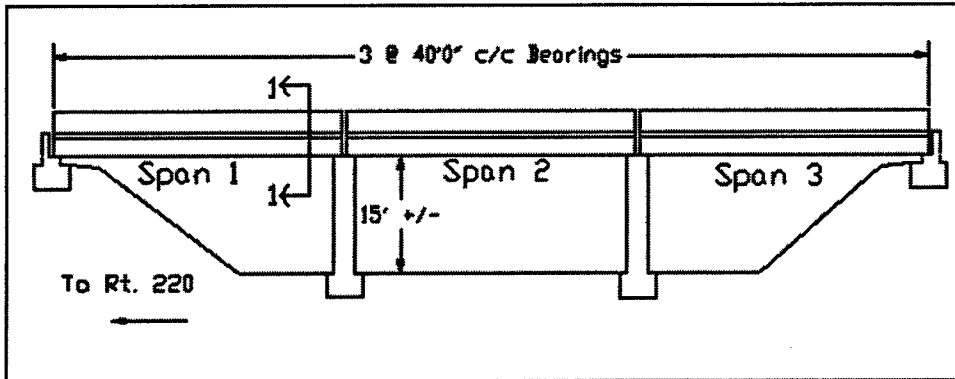

Figure 1 Franklin County Bridge elevation

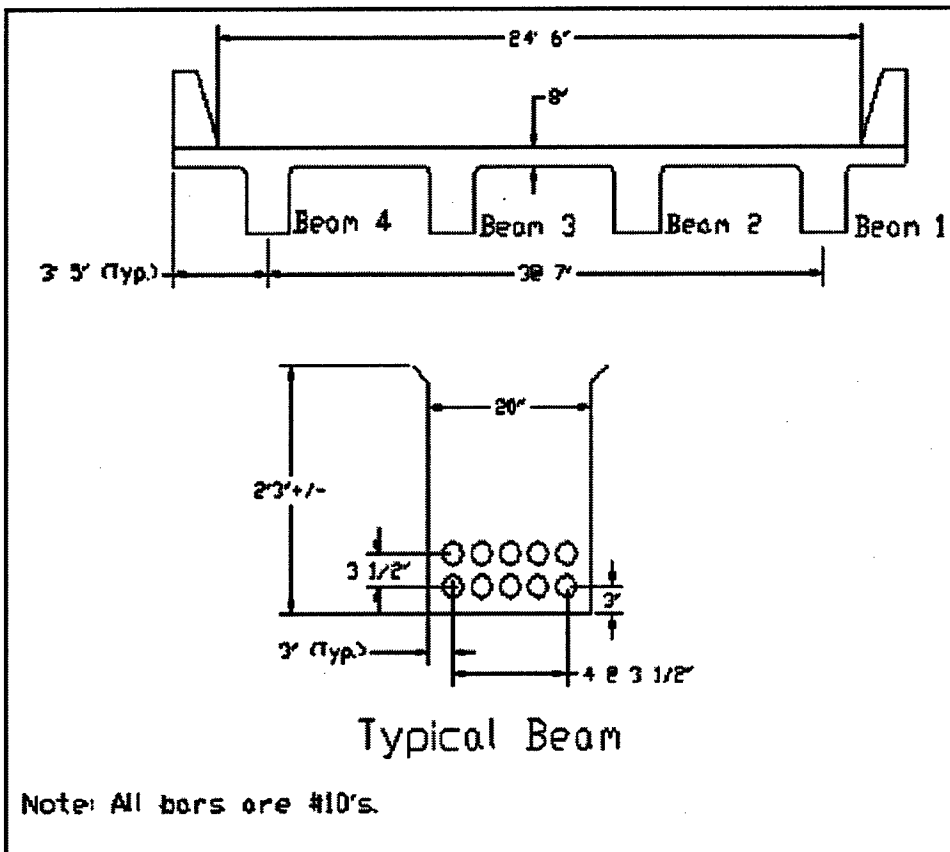

Figure 2. Franklin County Bridge Section 1-1

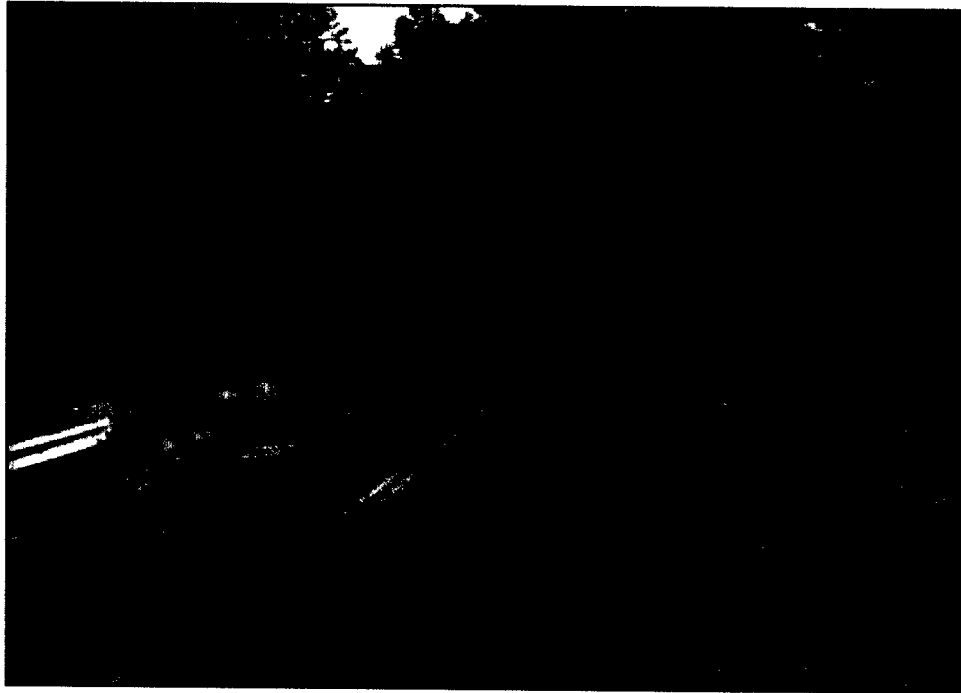

Figure 3. Franklin County Bridge

Patrick County Bridge

The second bridge carries VA Route 40 over Little Widgeon Creek near the town of Woolwine, Virginia in Patrick County. This one-span structure was constructed in 1947 and also has no skew with the roadway. However, unlike the Franklin County bridge, which is on a relatively straight stretch of road, the Patrick County bridge is on a rather sharp curve. Another difference between the two bridges lies in the bearing details. The Patrick County bridge super-structure bears directly on the abutment shelf instead of steel bearing pads. The compressive strength of the concrete and yield strength of the reinforcing steel used to construct this bridge were unavailable from original design drawings. Elevation and section views corresponding to this bridge are presented in Figure 4 and Figure 5, respectively (VDOT 1947). Figure 6 shows a picture of the Patrick County Bridge.

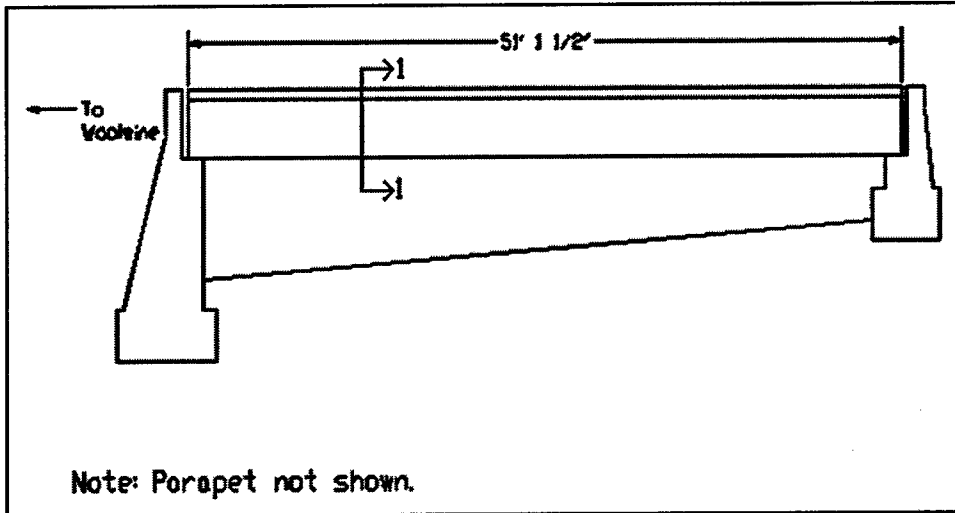

Figure 4. Patrick County Bridge elevation

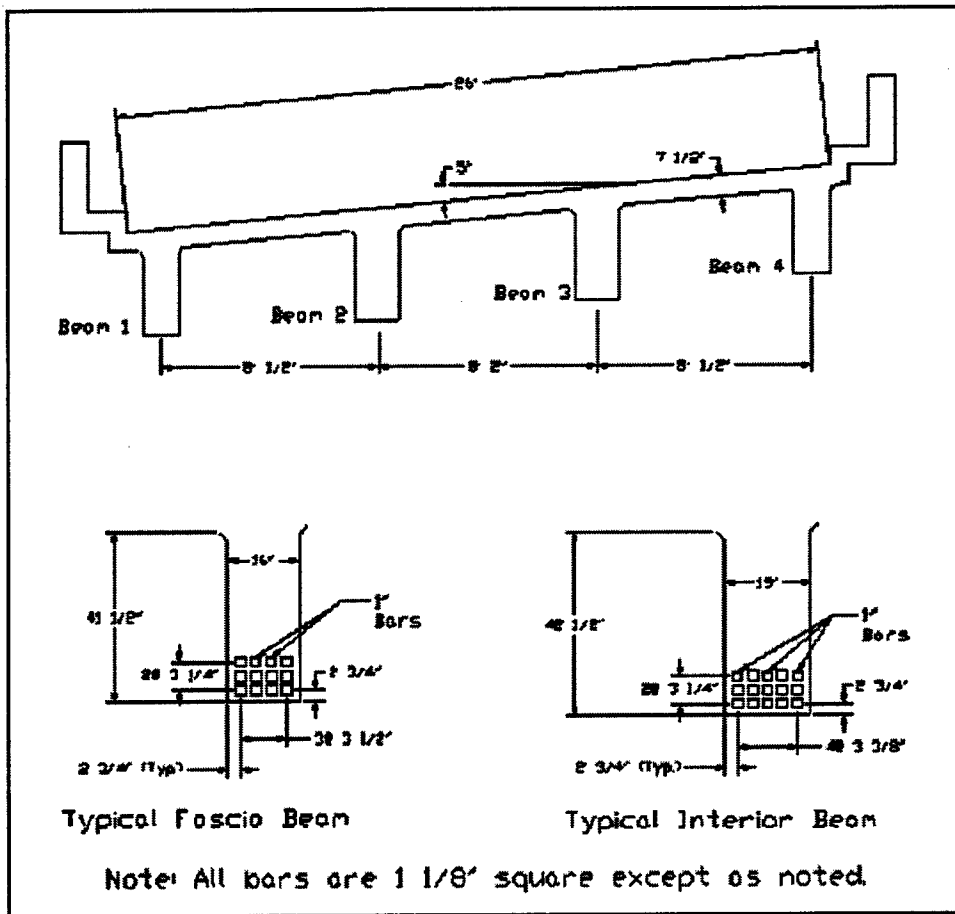

Figure 5. Patrick County Bridge Section 1-1

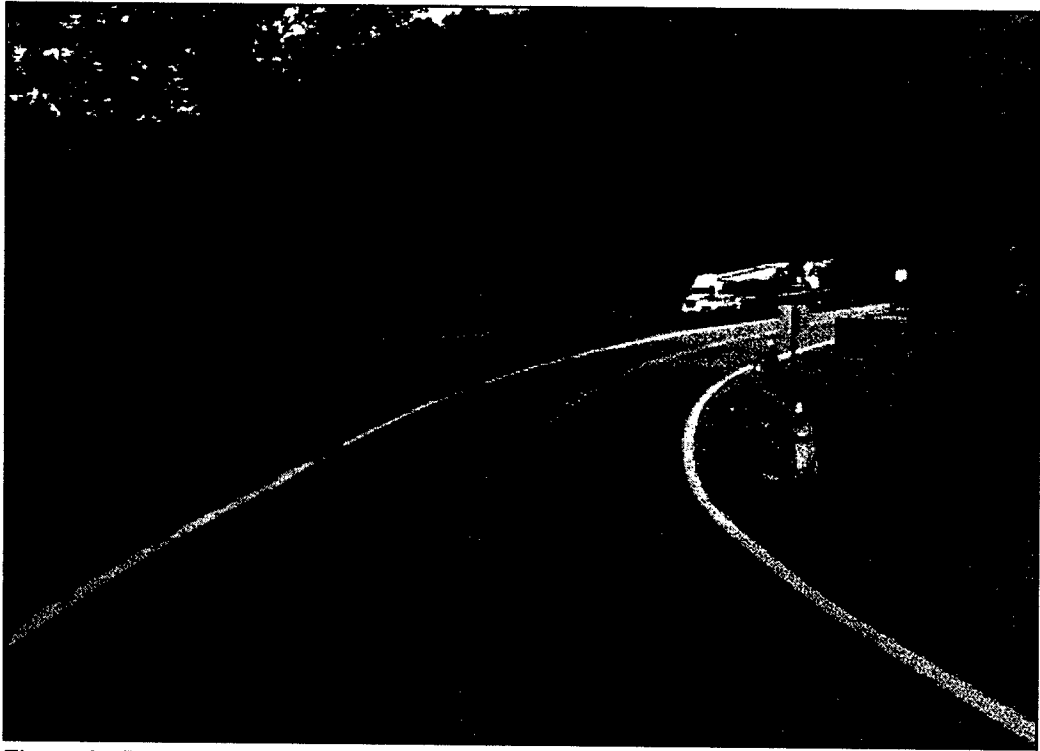

Figure 6. Patrick County Bridge

2 Test Procedure and Data

Test Procedure, Franklin County Bridge

The bridge was instrumented with deflectometers at the midspan of all four beams in span one. Then the deflectometers were connected to a MEGADAC model 3108 data acquisition system, with a sampling data rate of 200 deflections per second. The deflectometers measured T-beam deflections within +/- 0.002-in. throughout the testing. The test vehicles included a Virginia Department of Transportation (VDOT) dump truck and a U.S. Army Palletized Loading System (PLS) military vehicle. Testing sequences consisted of driving each vehicle separately across the bridge at creep speed (approximately 2 miles per hour) with three different transverse orientations on the bridge deck. Axle configurations and weights for these two vehicles can be seen in Figure 7 through Figure 10. Figures 11 a, b, and c show the transverse positions of the trucks on the bridge deck. Each truck crossed the bridge five times with their right wheel line directly over the right exterior girder and five more times with their right wheel line directly over the left exterior girder. Superposition of the effects due to these two truck orientations was used to replicate the presence of two trucks on the bridge simultaneously. For the purpose of this testing, the right lane of the bridge was designated as the lane headed towards U.S. Route 220. Each truck then crossed the bridge three times with their wheel lines centered between the two interior girders. Finally, the two trucks crossed the bridge with these same three orientations, this time at speeds between 38 and 45 miles per hour (as fast as they could safely cross the bridge). Estimations of the deflections due to the VDOT dump truck were calculated prior to the testing and can be found in Appendix B.

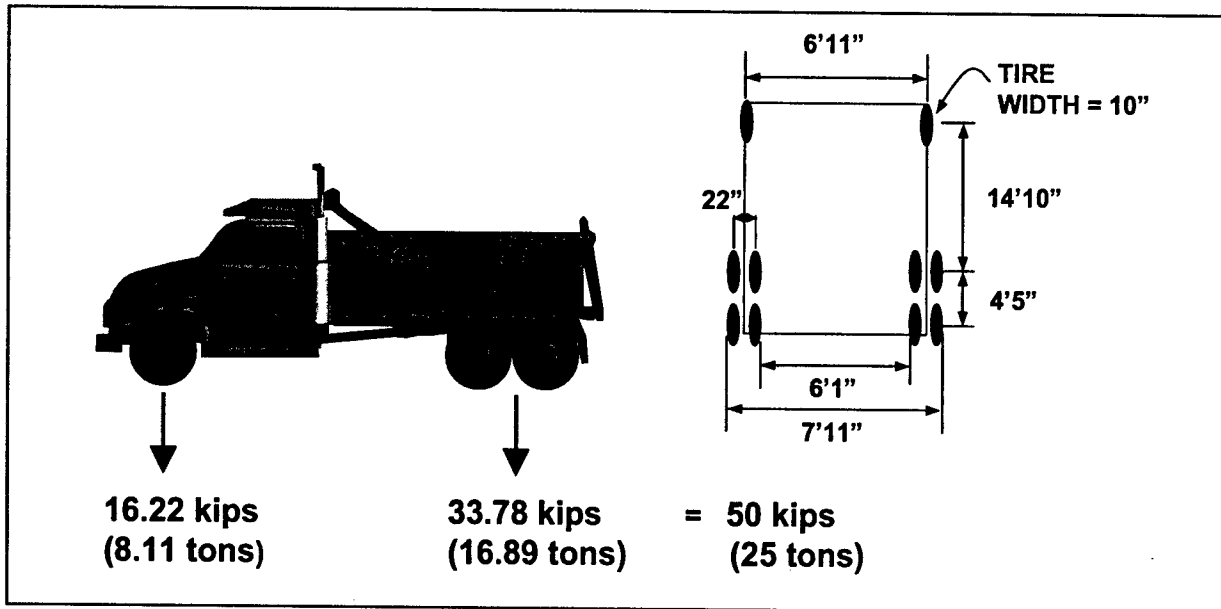
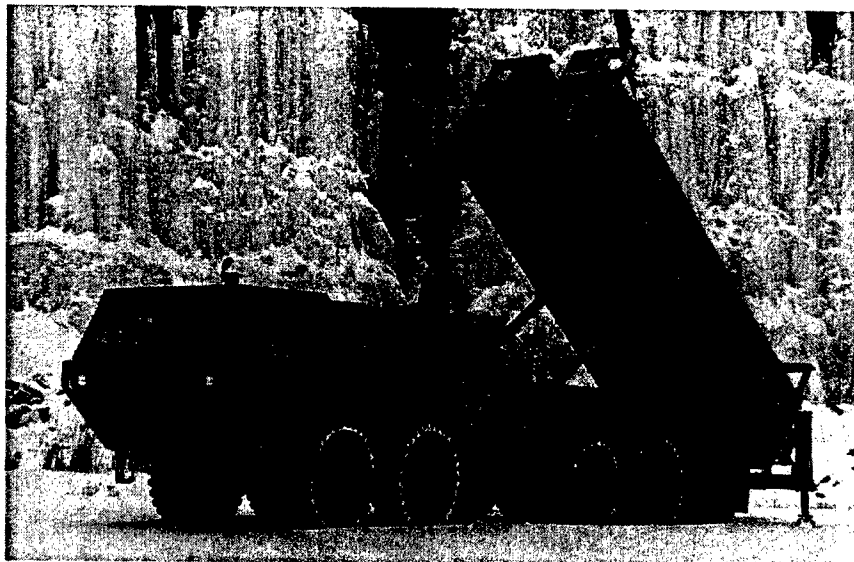

Figure 7. VDOT dump truck axle spacing and weights (Franklin County Bridge)



Vehicle Type: PLS M1075
Configuration: Empty, No Trailer, No Crane
Total Weight: 47140 lbs

Figure 8. PLS Military-Vehicle specifications

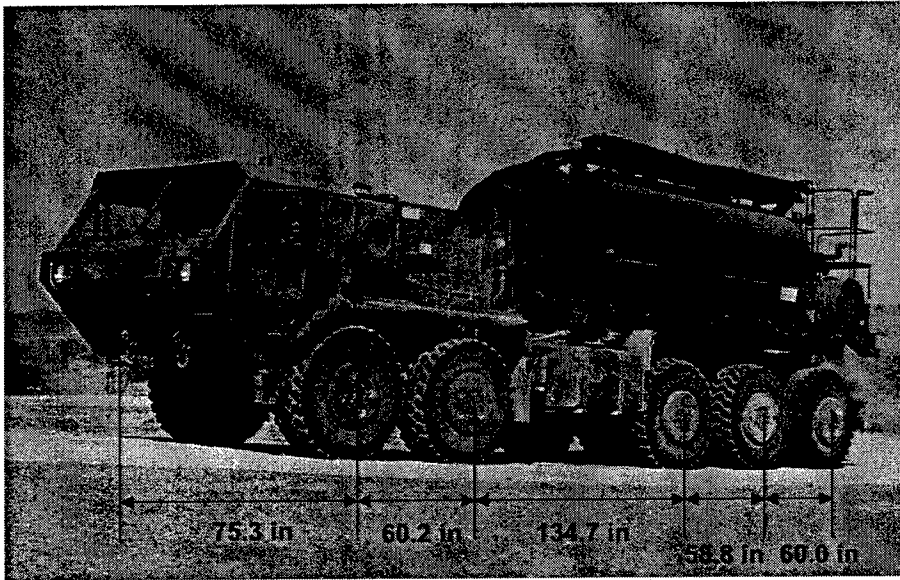

Figure 9. PLS Military-Vehicle axle spacing

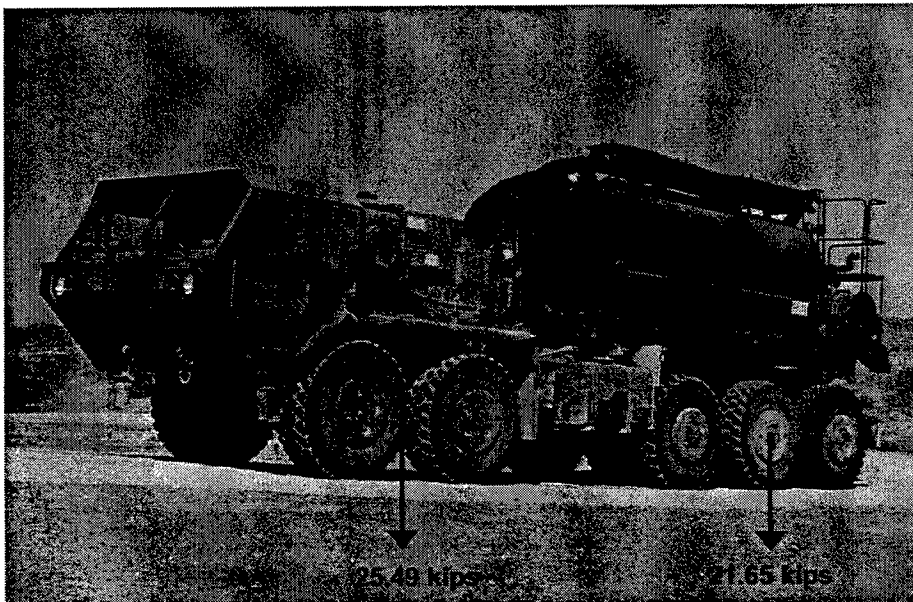

Figure 10. PLS Military-Vehicle axle weights

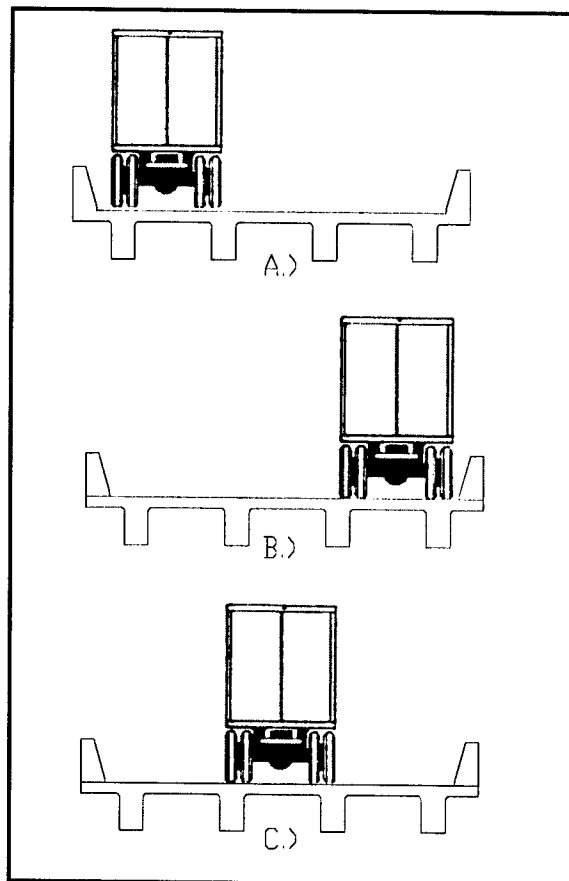

Figure 11. Truck orientations, Franklin County Bridge

Test Procedure, Patrick County Bridge

The Patrick County Bridge was tested using a procedure similar to that used on the Franklin County Bridge with one exception. For both the static and dynamic crossings, the wheel lines of the two trucks were placed 1 ft from the curb. Because of the bridge geometry, it was physically impossible to center the wheel line over the exterior girders. For this bridge, the right lane was designated as the lane heading in the direction towards the town of Woolwine. Figure 12 illustrates the axle configuration and weights for the VDOT dump truck used to test this bridge. The PLS truck used to test the Franklin County Bridge was also used to test the Patrick County Bridge (Figure 8 through Figure 10). Lateral truck orientations on the bridge deck are illustrated in Figure 13.

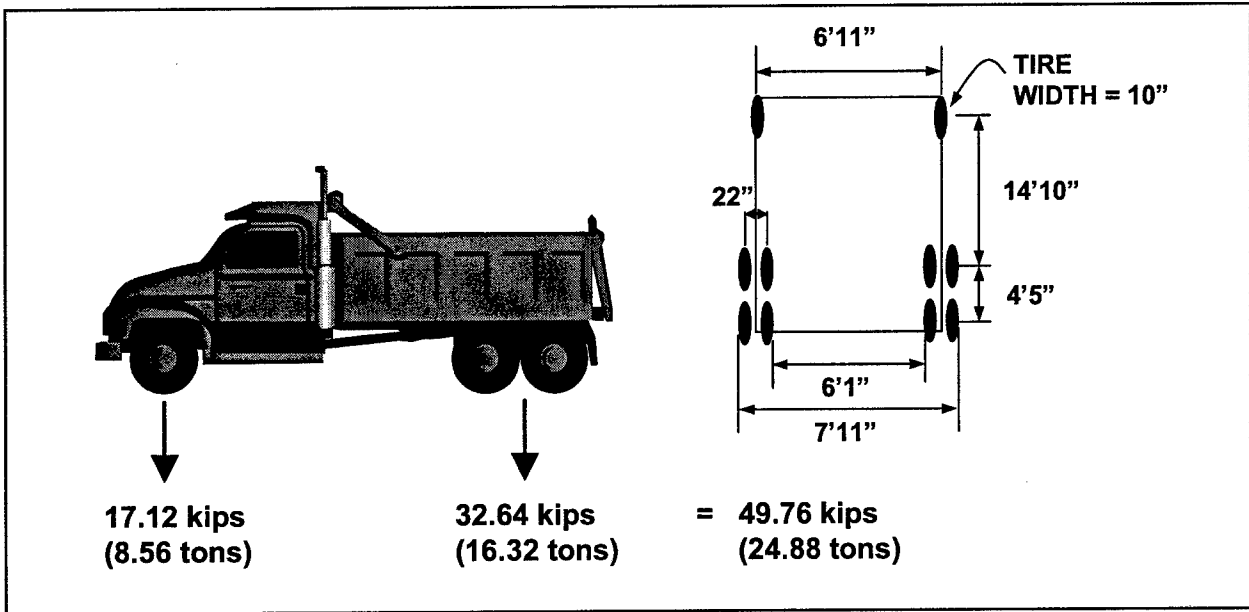

Figure 12. VDOT dump truck axle spacing and weights (Patrick County Bridge)

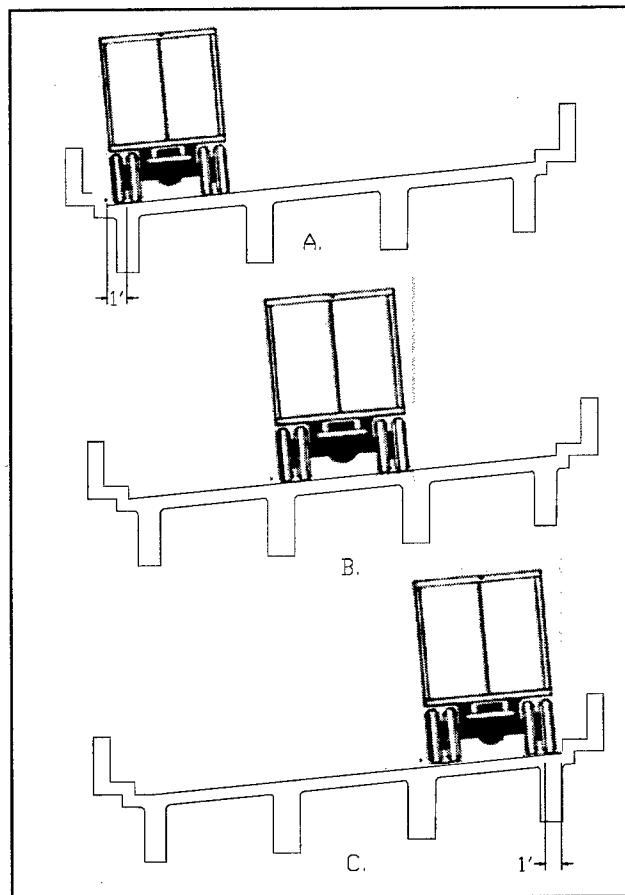

Figure 13. Truck orientations, Patrick County Bridge

Sample Data, Franklin County Bridge

Table 3 shows the absolute maximum deflection of all four beams for each lateral position of both vehicles. A sample vehicle crossing (static and dynamic) for each lateral truck position is presented. For example, the first deflection in the table (0.035") is the maximum deflection of beam one due to a sample static crossing of the VDOT dump truck over the right exterior girder. It was assumed that the maximum deflection of the four individual girders occurred simultaneously. Inspection of the recorded data proves this to be a very reasonable assumption. Table 4 (static crossings) and Table 5 (dynamic crossings) show the maximum, minimum, and average of the largest deflections recorded for each beam under truck crossings with the same transverse orientation. Figures 14 and 16 plot the recorded deflection versus time for sample static crossings with the dump truck and PLS truck. Figures 15 and 17 show the maximum deflection of the four individual girders for the truck crossings plotted in Figures 14 and 16, respectively. Figure 18 compares the static and dynamic deflections of the most heavily loaded girder due to sample dump truck crossings of similar orientation.

Test Sequence	Deflection (in.)			
	Beam 1	Beam 2	Beam 3	Beam 4
Static Test:				
DR	0.035	0.030	0.015	0.005
DC	0.015	0.035	0.030	0.015
PR	0.025	0.025	0.015	0.005
PC	0.010	0.025	0.025	0.015
DL	0.005	0.015	0.030	0.035
PL	0.005	0.015	0.025	0.030
2D	0.035	0.045	0.045	0.045
2P	0.030	0.040	0.040	0.040
Dynamic Test:				
DR	0.035	0.035	0.015	0.010
DC	0.020	0.040	0.035	0.020
PR	0.025	0.030	0.015	0.010
PC	0.010	0.030	0.030	0.020
DL	0.010	0.025	0.035	0.040
PL	0.010	0.025	0.030	0.025
DR =	Dump Truck Over Right Exterior Girder			
DC =	Dump Truck Centered Between Interior Girders			
PR =	PLS Truck Over Right Exterior Girder			
PC =	PLS Truck Centered Between Interior Girders			
DL =	Dump Truck Over Left Exterior Girder			
PL =	PLS Truck Over Left Exterior Girder			
2D =	2 Dump Trucks, One Over Each Exterior Girder			
2P =	2 PLS Trucks, One Over Each Exterior Girder			

Table 4 Beam Deflections Under Static Loading (Franklin County Bridge)					
Truck Orientation		Deflection (in.)			
		Beam 1	Beam 2	Beam 3	Beam 4
DR	Minimum	0.030	0.030	0.015	0.005
	Average	0.035	0.030	0.015	0.005
	Maximum	0.035	0.030	0.015	0.005
DC	Minimum	0.015	0.035	0.030	0.015
	Average	0.015	0.035	0.030	0.015
	Maximum	0.015	0.035	0.030	0.015
PR	Minimum	0.025	0.025	0.015	0.005
	Average	0.025	0.025	0.015	0.005
	Maximum	0.025	0.030	0.015	0.005
PC	Minimum	0.010	0.025	0.025	0.015
	Average	0.010	0.025	0.025	0.015
	Maximum	0.010	0.025	0.025	0.015
DL	Minimum	0.005	0.015	0.030	0.035
	Average	0.005	0.015	0.030	0.035
	Maximum	0.005	0.015	0.030	0.040
PL	Minimum	0.005	0.015	0.025	0.030
	Average	0.005	0.015	0.025	0.030
	Maximum	0.005	0.015	0.025	0.030
2D	Minimum	0.035	0.045	0.045	0.040
	Average	0.040	0.045	0.045	0.040
	Maximum	0.040	0.045	0.045	0.045
2P	Minimum	0.030	0.040	0.040	0.035
	Average	0.030	0.040	0.040	0.035
	Maximum	0.030	0.045	0.040	0.035

Table 5 Beam Deflections Under Dynamic Loading (Franklin County Bridge)					
Truck Orientation		Deflection (in.)			
		Beam 1	Beam 2	Beam 3	Beam 4
DR	Minimum	0.035	0.035	0.015	0.010
	Average	0.035	0.035	0.015	0.010
	Maximum	0.035	0.040	0.020	0.010
DC	Minimum	0.015	0.040	0.030	0.015
	Average	0.020	0.040	0.035	0.020
	Maximum	0.020	0.040	0.035	0.020
PR	Minimum	0.020	0.030	0.015	0.010
	Average	0.025	0.030	0.015	0.010
	Maximum	0.025	0.030	0.020	0.010
PC	Minimum	0.010	0.030	0.025	0.015
	Average	0.010	0.030	0.025	0.015
	Maximum	0.015	0.030	0.030	0.020
DL	Minimum	0.010	0.025	0.035	0.040
	Average	0.010	0.025	0.040	0.045
	Maximum	0.010	0.030	0.040	0.045
PL	Minimum	0.005	0.02	0.030	0.025
	Average	0.010	0.025	0.030	0.025
	Maximum	0.010	0.025	0.030	0.025

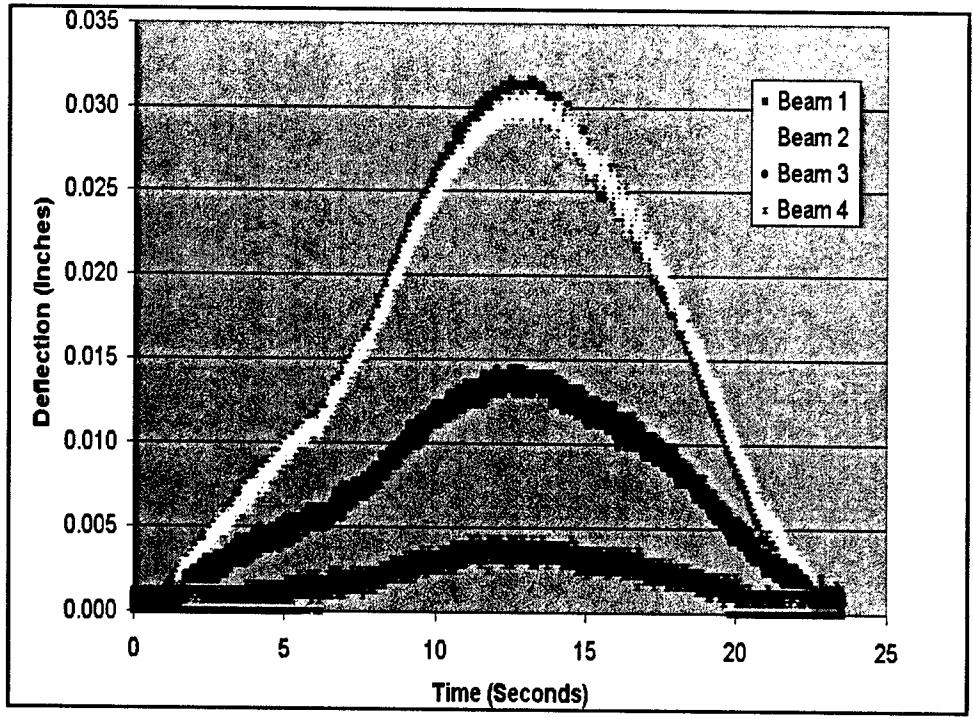

Figure 14. Variation of Deflection vs. Time under static loading - dump truck over right exterior girder (Franklin County Bridge)

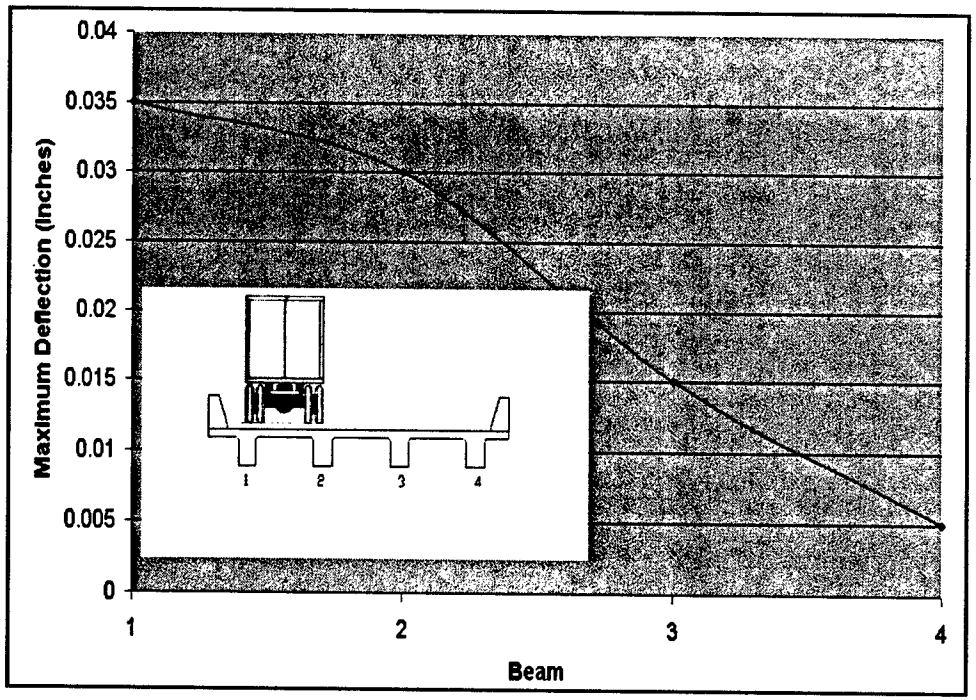

Figure 15. Maximum Beam Deflection under static loading - dump truck over right exterior girder (Franklin County Bridge)

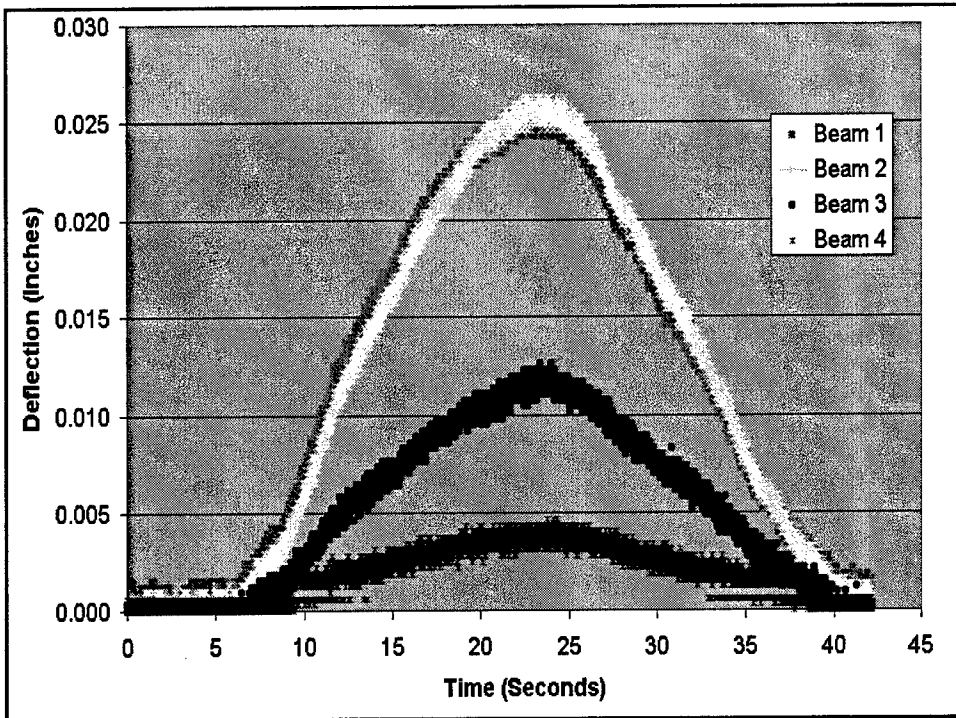

Figure 16. Variation of Deflection vs. Time under static loading – PLS Military-Vehicle over right exterior girder (Franklin County Bridge)

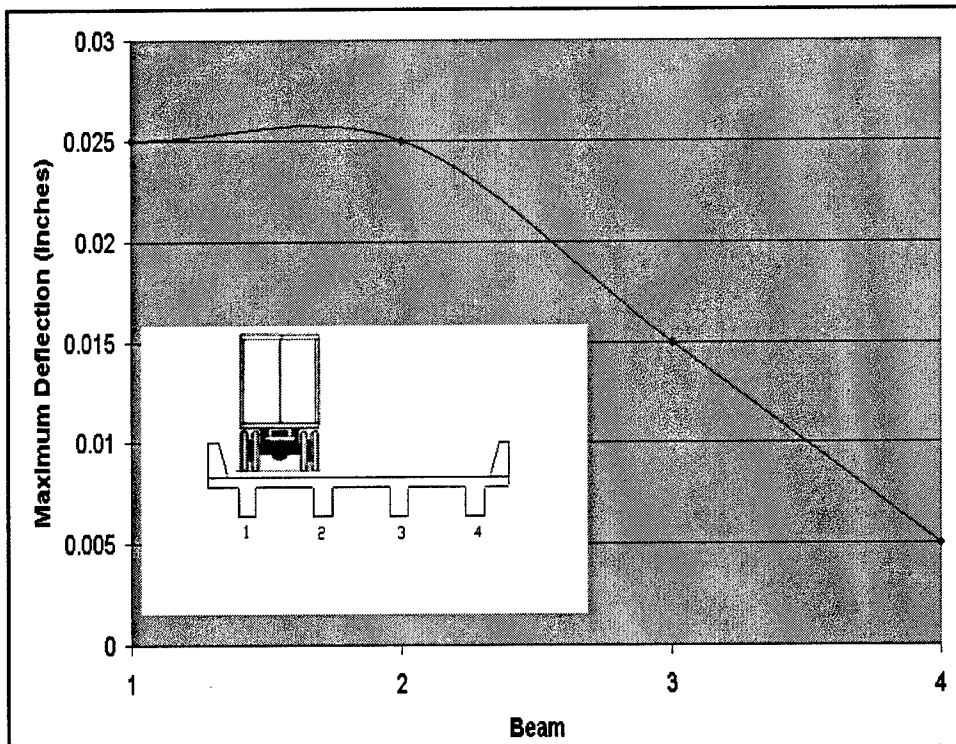

Figure 17. Maximum Beam Deflection under static loading - PLS Military-Vehicle over right exterior girder (Franklin County Bridge)

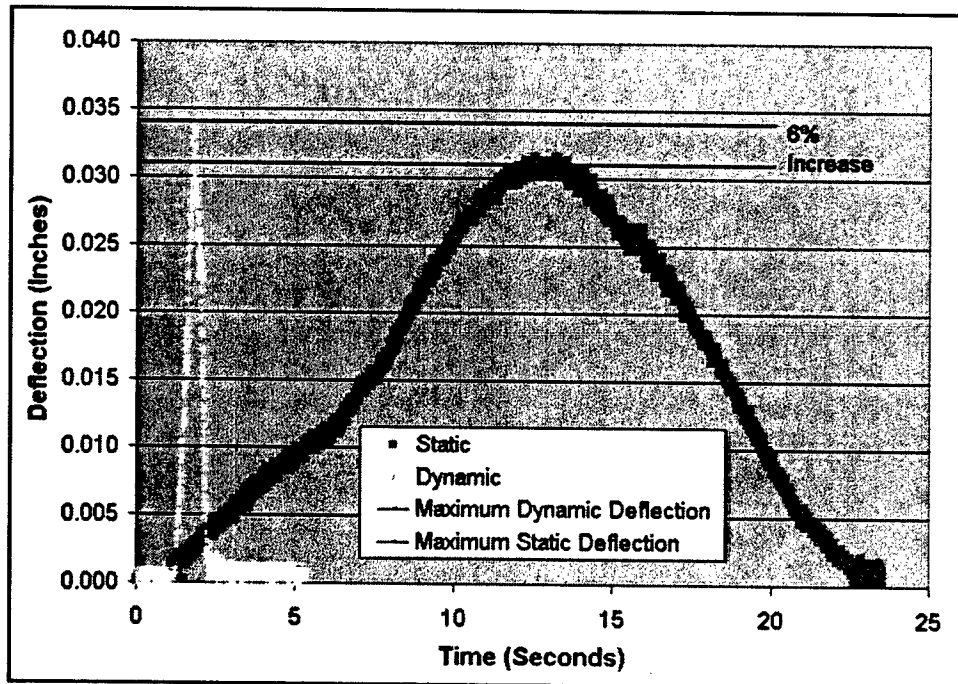

Figure 18. Comparison of Static and Dynamic Deflections, dump truck over right exterior girder (Franklin County Bridge)

Sample Data, Patrick County Bridge

Table 6 shows the absolute maximum deflection of the four beams for each lateral position of the two trucks. A sample truck crossing (static and dynamic) for each lateral truck position was chosen for the purpose of this table. For example, the first deflection in the table (0.040") is the maximum deflection of beam one due to a sample static crossing of the VDOT dump truck 1 ft from the right curb. It was assumed that the maximum deflection of the four individual girders occurred simultaneously. Inspection of the recorded data proves this to be a very reasonable assumption. Table 7 (static crossings) and Table 8 (dynamic crossings) show the maximum, minimum, and average of the largest deflections recorded for each beam under truck crossings with the same transverse orientation. Figures 19 and 21 plot the recorded deflection versus time for sample static crossings with the dump truck and PLS truck. Figures 20 and 22 show the maximum deflection of the four individual girders for the truck crossings plotted in Figures 19 and 21, respectively. Figure 23 compares the static and dynamic deflections of the most heavily loaded girder due to sample dump truck crossings of similar orientation.

Table 6 Maximum Beam Deflections (Patrick County Bridge)				
Test Sequence	Deflection (in.)			
	Beam 1	Beam 2	Beam 3	Beam 4
Static Test:				
DR	0.040	0.030	0.020	0.010
DC	0.020	0.030	0.030	0.015
PR	0.035	0.025	0.010	0.005
PC	0.015	0.025	0.025	0.015
DL	0.005	0.015	0.030	0.040
PL	0.005	0.015	0.025	0.035
2D	0.045	0.045	0.055	0.050
2P	0.040	0.040	0.040	0.035
Dynamic Test:				
DR	0.040	0.035	0.020	0.010
DC	0.025	0.035	0.035	0.020
PR	0.035	0.035	0.020	0.010
PC	0.020	0.025	0.035	0.025
DL	0.010	0.020	0.040	0.050
PL	0.015	0.020	0.035	0.035
DR = Dump Truck One Foot From Right Curb DC = Dump Truck Centered Between Interior Girders PR = PLS Truck One Foot From Right Curb PC = PLS Truck Centered Between Interior Girders DL = Dump Truck One Foot From Left Curb PL = PLS Truck One Foot From Left Curb 2D = 2 Dump Trucks, One Truck One Foot From Each Curb 2P = 2 PLS Trucks, One Truck One Foot From Each Curb				

Table 7 Beam Deflections Under Static Loading (Patrick County Bridge)					
Truck Orientation		Deflection (in)			
		Beam 1	Beam 2	Beam 3	Beam 4
DR	Minimum	0.040	0.030	0.020	0.010
	Average	0.040	0.030	0.020	0.010
	Maximum	0.045	0.030	0.020	0.010
DC	Minimum	0.020	0.030	0.025	0.015
	Average	0.020	0.030	0.030	0.015
	Maximum	0.020	0.030	0.030	0.015
PR	Minimum	0.035	0.025	0.010	0.005
	Average	0.035	0.025	0.010	0.005
	Maximum	0.035	0.025	0.010	0.005
PC	Minimum	0.015	0.025	0.025	0.015
	Average	0.015	0.025	0.025	0.015
	Maximum	0.015	0.025	0.025	0.015
DL	Minimum	0.005	0.015	0.030	0.040
	Average	0.005	0.015	0.030	0.040
	Maximum	0.005	0.015	0.030	0.040
PL	Minimum	0.005	0.015	0.025	0.035
	Average	0.005	0.015	0.030	0.035
	Maximum	0.005	0.015	0.030	0.035
2D	Minimum	0.045	0.045	0.050	0.050
	Average	0.045	0.045	0.050	0.050
	Maximum	0.050	0.045	0.050	0.050
2P	Minimum	0.040	0.040	0.035	0.040
	Average	0.040	0.040	0.040	0.040
	Maximum	0.040	0.040	0.040	0.040

Table 8 Beam Deflections Under Dynamic Loading (Patrick County Bridge)					
Truck Orientation		Deflection (in)			
		Beam 1	Beam 2	Beam 3	Beam 4
DR	Minimum	0.040	0.035	0.015	0.005
	Average	0.045	0.035	0.020	0.010
	Maximum	0.050	0.040	0.025	0.010
DC	Minimum	0.020	0.030	0.035	0.020
	Average	0.020	0.030	0.035	0.020
	Maximum	0.025	0.035	0.035	0.020
PR	Minimum	0.035	0.035	0.020	0.010
	Average	0.035	0.035	0.020	0.010
	Maximum	0.035	0.035	0.020	0.010
PC	Minimum	0.015	0.025	0.030	0.020
	Average	0.020	0.025	0.035	0.025
	Maximum	0.020	0.030	0.035	0.030
DL	Minimum	0.010	0.015	0.035	0.045
	Average	0.015	0.020	0.035	0.050
	Maximum	0.015	0.025	0.040	0.050
PL	Minimum	0.015	0.020	0.035	0.035
	Average	0.015	0.020	0.035	0.035
	Maximum	0.015	0.020	0.035	0.035

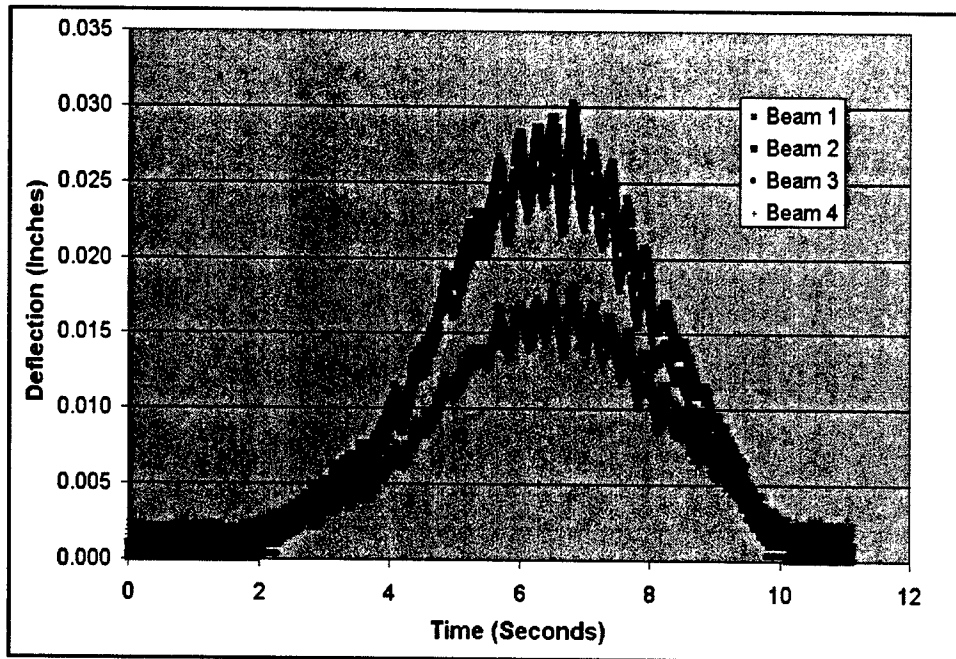

Figure 19. Variation of Deflection vs. time under static loading - dump truck centered between interior girders (Patrick County Bridge)

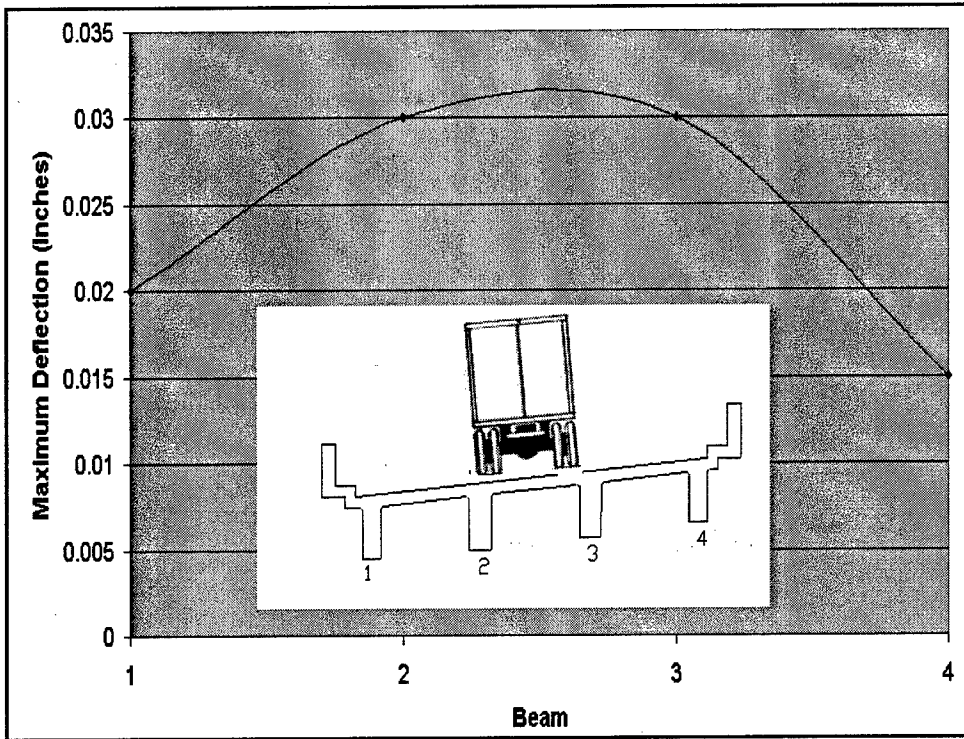

Figure 20. Maximum Beam Deflection under static loading - dump truck centered between interior girders (Patrick County Bridge)

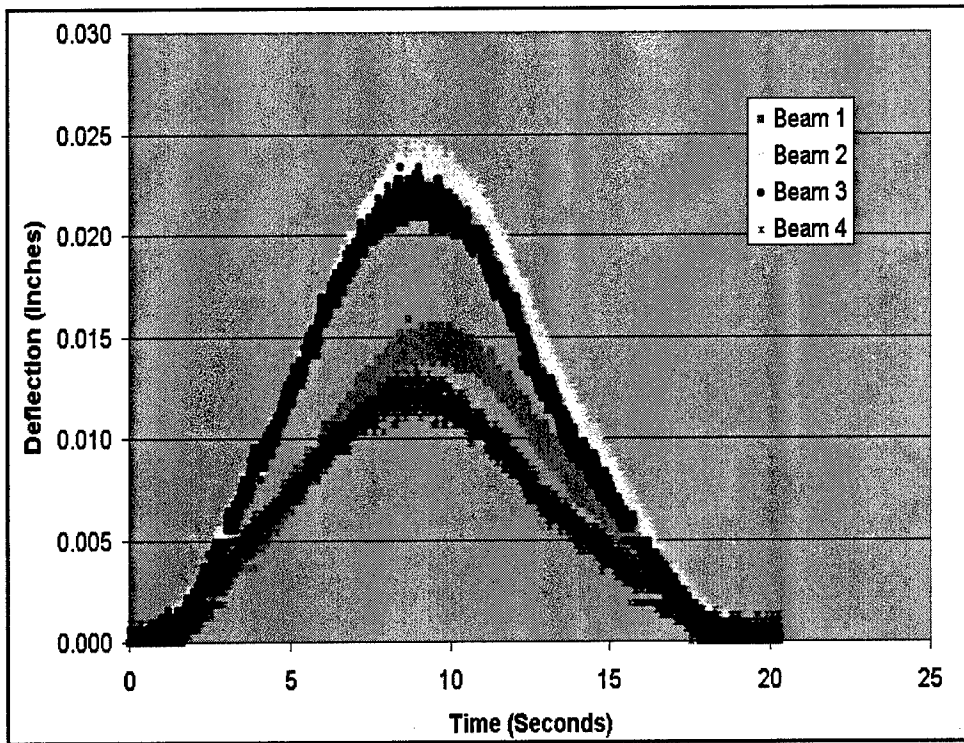

Figure 21. Variation of Deflection vs. Time under static loading - PLS Military-Vehicle centered between interior girders (Patrick County Bridge)

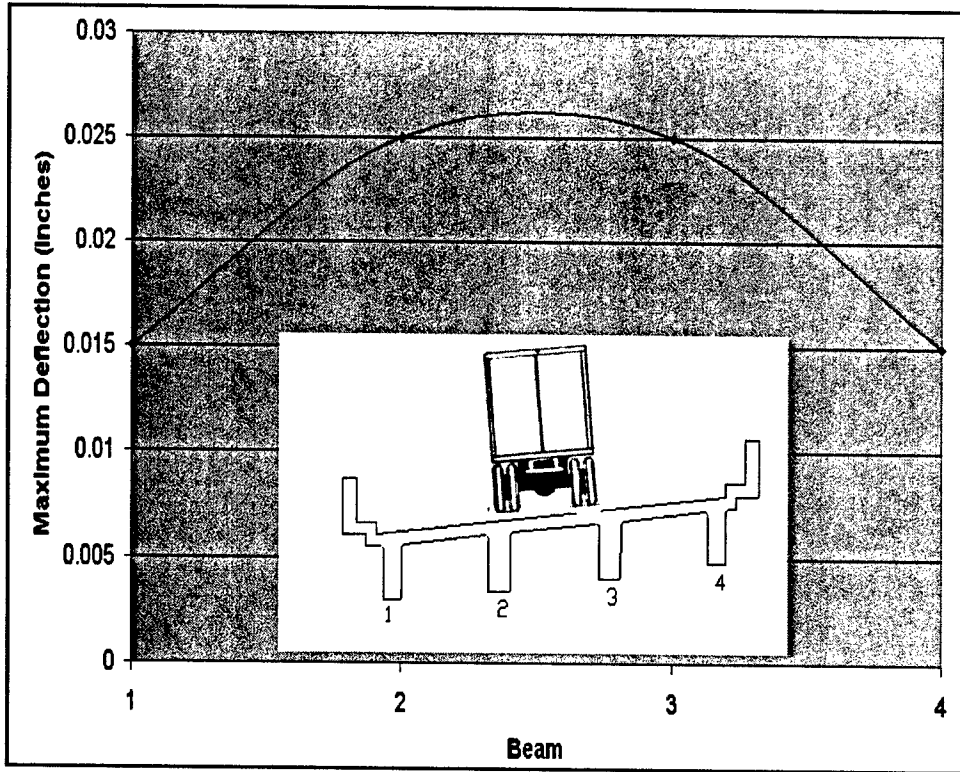

Figure 22. Maximum Beam Deflection under static loading - PLS Military-Vehicle centered between interior girders (Patrick County Bridge)

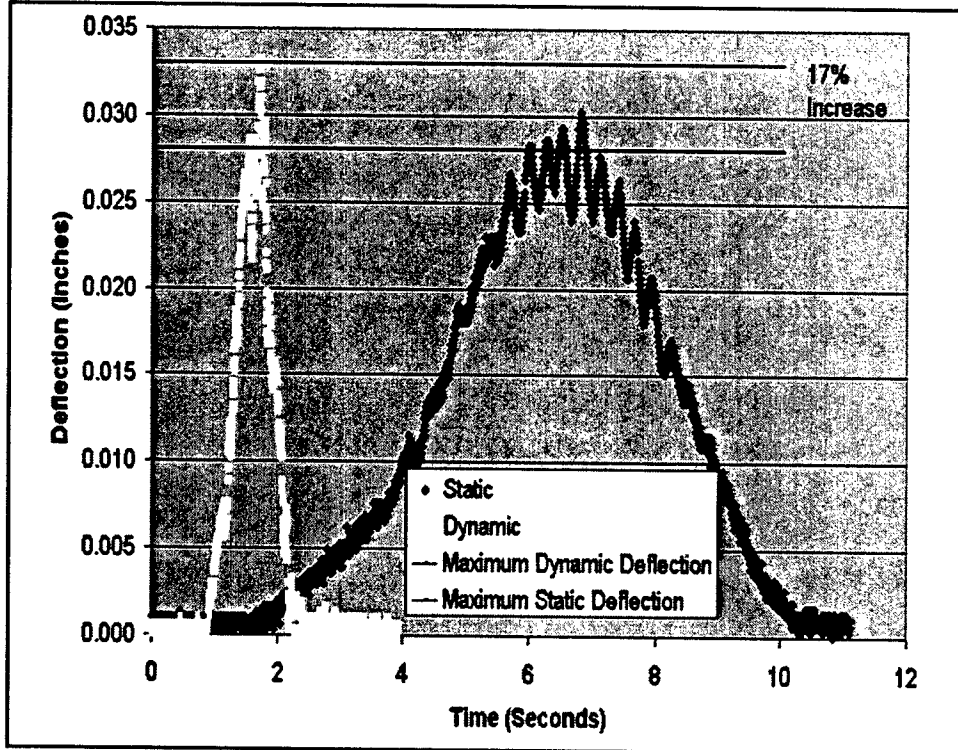

Figure 23. Comparison of Static and Dynamic Deflections, dump truck centered between interior girders (Patrick County Bridge)

3 Data Analysis and Results

Lateral Live Load Distribution Factors

By measuring the deflection of each T-beam in a bridge (at the same distance from the support) under static loading, the fraction of the total load in each T-beam can be calculated. The lateral live load distribution factor, by definition, is the largest fraction of the total load that any one T-beam receives. Two important assumptions must be made in order to justify this quick and straightforward analysis. The first assumption is linear elastic behavior of the reinforced concrete. This implies a linear relationship between material stress and strain and ultimately a linear relationship between the force applied to the T-beam and the deflection the T-beam undergoes. It should be noted that cracks did open in the bottom of the T-beams of the bridge under load and closed when the load was removed. Therefore, the assumption of linear elasticity was deemed reasonable. Secondly, it is assumed that the four T-beams in each bridge have approximately equal stiffness. Since all of the T-beams have nearly the same dimensions, quantities of reinforcement, and material properties, this is also a reasonable assumption. Geometric and material non-linearity was neglected since the bridge experienced very small deflections and preliminary calculations show that yielding of the reinforcing steel did not occur. The equation used to calculate the live load distribution factor is as follows:

$$DF = \delta_{\max} / (\delta_1 + \delta_2 + \delta_3 + \delta_4) \quad \text{(Equation 1)}$$

where,

DF	=	lateral live load distribution factor
$\delta_1, \delta_2, \delta_3, \delta_4$	=	maximum deflection in girders 1-4, respectively
δ_{\max}	=	maximum deflection value between δ_1 and δ_4 (to determine distribution factor for exterior girder), or maximum deflection value between δ_2 and δ_3 (to determine distribution factor for interior girder)

Equation 1 can be used to compute the distribution factor for interior and exterior girders for each crossing, whether static or dynamic, after the largest deflection in each girder for that particular crossing is determined. To obtain a more representative measure of the "true" distribution factor, the computed

distribution factors for similar truck crossings were averaged. Repetitions of similar truck crossings varied between three and five. Distribution factors due to the presence of two trucks on the bridge were simulated using superposition. The maximum deflection in each girder resulting from the truck crossing the bridge over the left exterior girder was added to the maximum deflection in each girder resulting from the truck crossing the bridge over the right exterior girder. Then Equation 1 was applied as before. This distribution factor was then multiplied by two to account for the fact that two axles were loading the bridge simultaneously.

Distribution Factors, Franklin County Bridge

Figures 24 and 25 show the live load distribution factors for interior and exterior girders for the VDOT dump truck and the PLS truck, respectively. The computed distribution factors for similar truck orientations were averaged for the purpose of these figures. Tables 9 and 10 compare the largest distribution factor (for all truck orientations) for interior and exterior girders (one and two lanes loaded) to the values specified in the AASHTO Standard Specification and AASHTO LRFD. Figure 26 compares the largest distribution factors for interior and exterior girders (for all truck orientations) for the VDOT dump truck with the U.S. Army PLS truck.

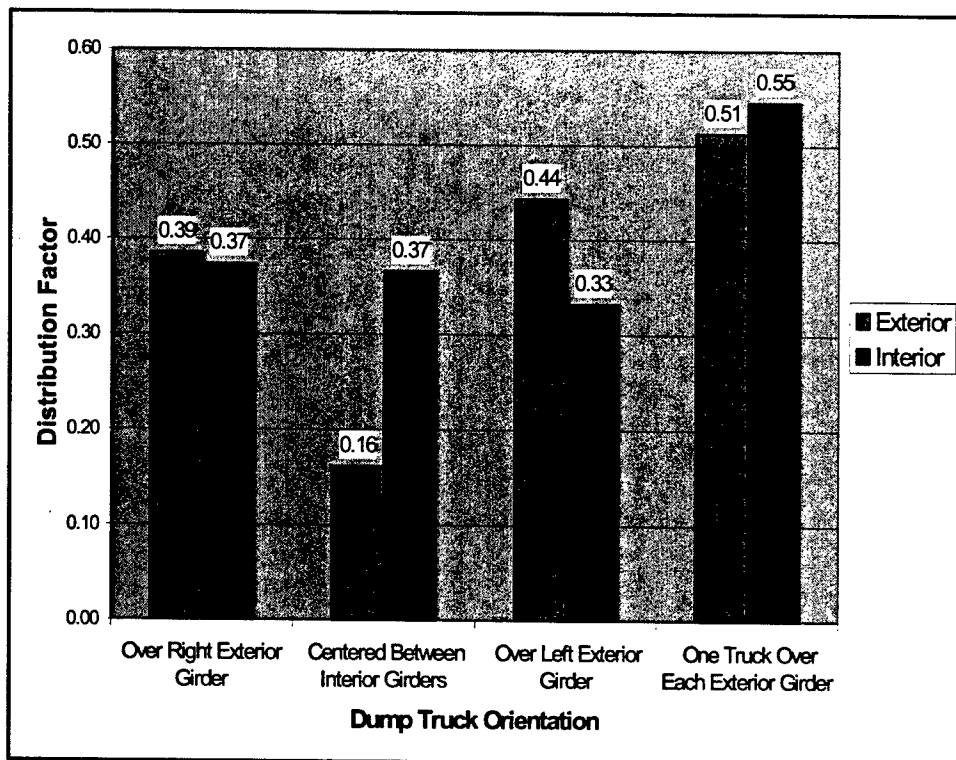

Figure 24. Distribution Factors for VDOT dump truck (Franklin County Bridge)

Table 9 Comparison of AASHTO and Measured Distribution Factors for VDOT Dump Truck (Franklin County Bridge)						
	Interior Girder			Exterior Girder		
	SS	LRFD	Measured	SS	LRFD	Measured
Single Lane	0.57	0.50	0.37	0.59	0.59	0.44
Two Lanes	0.59	0.65	0.55	0.59	0.52	0.51

SS=AASHTO Standard Specifications
LRFD=AASHTO LRFD Specifications

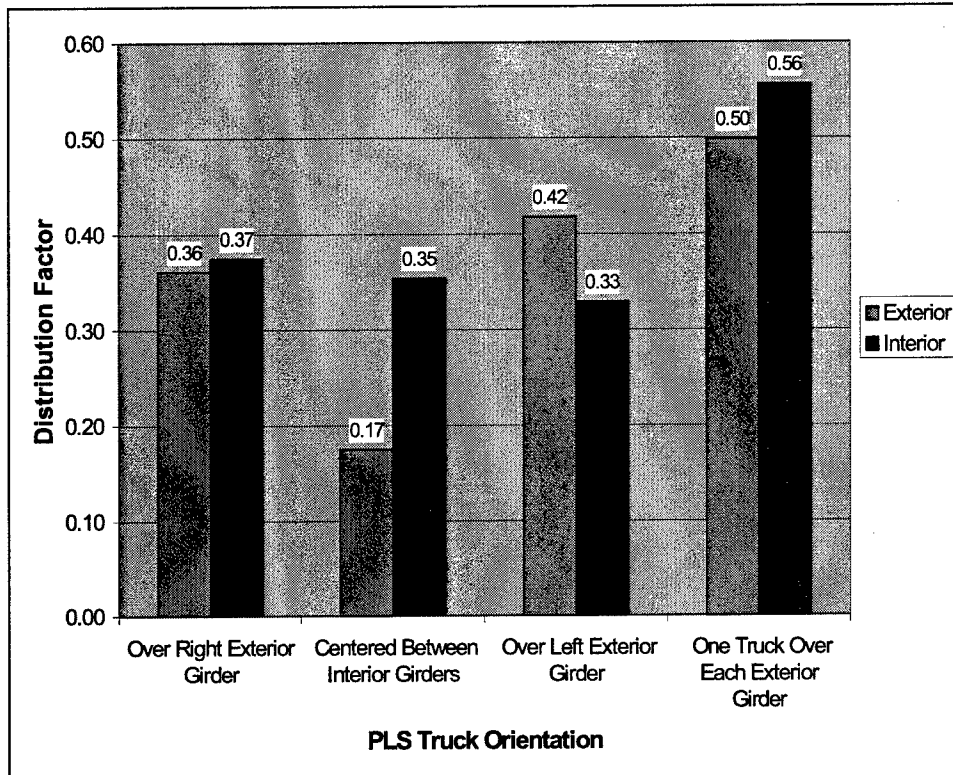

Figure 25. Distribution Factors for PLS Military-Vehicle (Franklin County Bridge)

Table 10 Comparison of AASHTO and Measured Distribution Factors for PLS Military-Vehicle (Franklin County Bridge)						
	Interior Girder			Exterior Girder		
	SS	LRFD	Measured	SS	LRFD	Measured
Single Lane	0.57	0.50	0.37	0.59	0.59	0.42
Two Lanes	0.59	0.65	0.56	0.59	0.52	0.50

SS=AASHTO Standard Specifications
LRFD=AASHTO LRFD Specifications

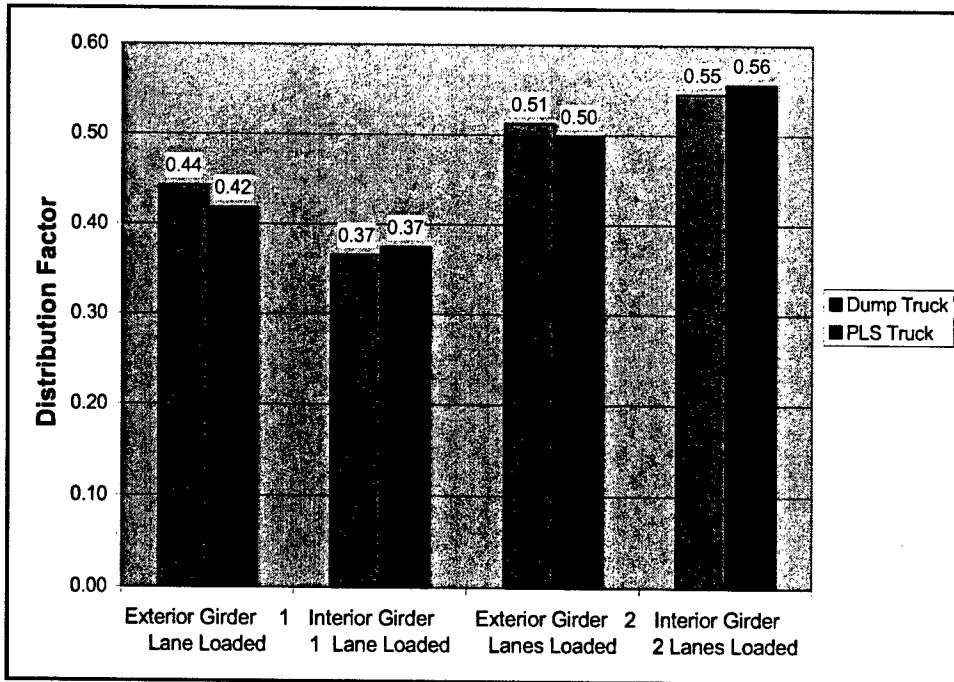

Figure 26. Comparison of Distribution Factors for VDOT Dump Truck and PLS Military-Vehicle (Franklin County Bridge)

Distribution Factors, Patrick County Bridge

Figures 27 and 28 show the live load distribution factors for interior and exterior girders for the VDOT dump truck and the PLS truck, respectively. The computed distribution factors for similar truck orientations were averaged for the purpose of this figure. Tables 11 and 12 compare the largest distribution factor (for all truck orientations) for interior and exterior girders (one and two lanes loaded) to the values specified in the AASHTO Standard Specification and AASHTO LRFD. Figure 29 compares the largest distribution factors for interior and exterior girders (for all truck orientations) for the VDOT dump truck with the U.S. Army PLS truck.

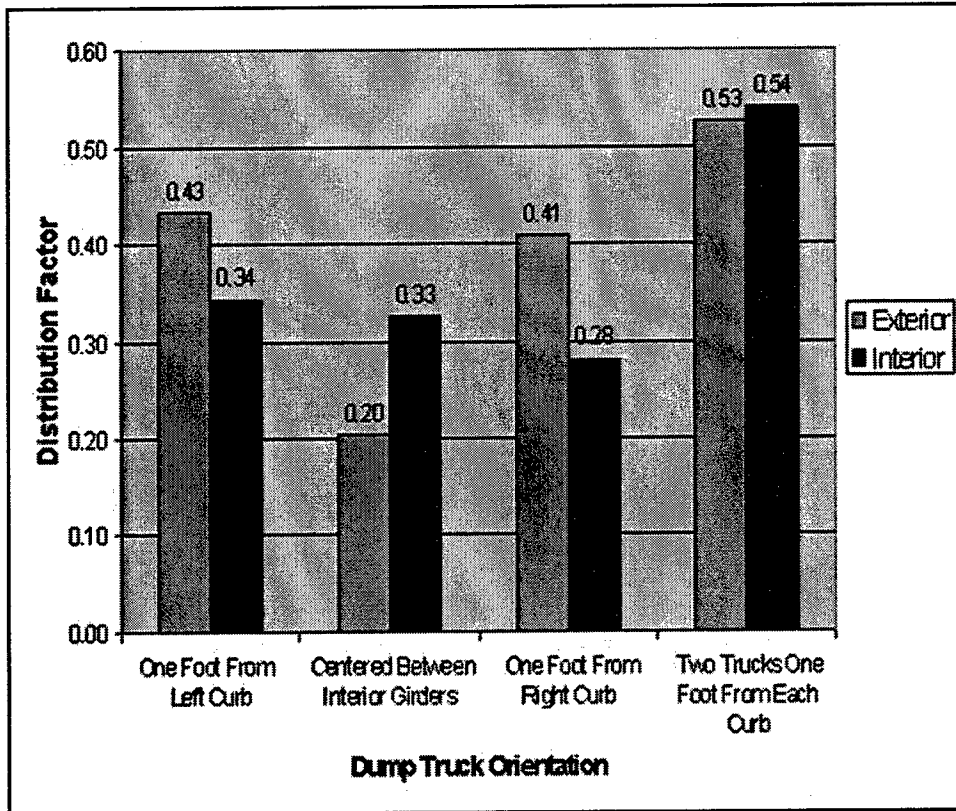

Figure 27. Distribution Factors for VDOT dump truck (Patrick County Bridge)

Table 11
Comparison of AASHTO and Measured Distribution Factors for VDOT Dump Truck (Patrick County Bridge)

	Interior Girder			Exterior Girder		
	SS	LRFD	Measured	SS	LRFD	Measured
Single Lane	0.63	0.63	0.63	0.63	0.63	0.63
Two Lanes	0.68	0.68	0.68	0.68	0.68	0.68

SS=AASHTO Standard Specifications
 LRFD=AASHTO LRFD Specifications

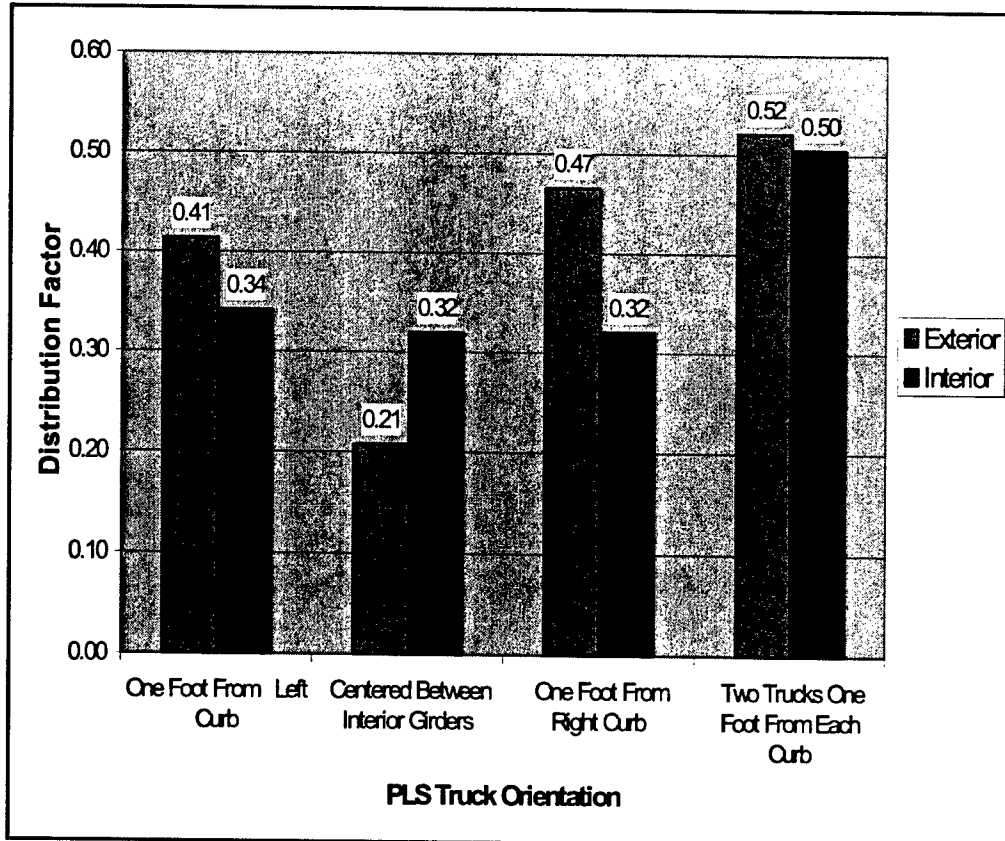

Figure 28. Distribution Factors for PLS Military-Vehicle (Patrick County Bridge)

	Interior Girder			Exterior Girder		
	SS	LRFD	Measured	SS	LRFD	Measured
Single Lane	0.63	0.57	0.34	0.59	0.59	0.47
Two Lanes	0.68	0.77	0.50	0.59	0.59	0.52

SS=AASHTO Standard Specifications
LRFD=AASHTO LRFD Specifications

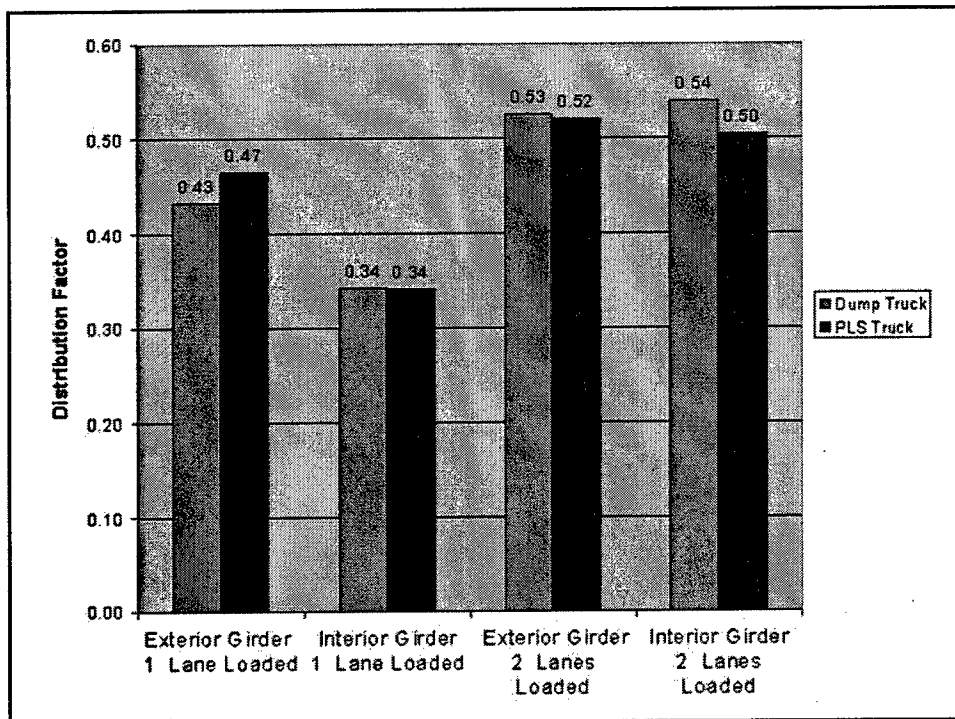

Figure 29. Comparison of Distribution Factors for VDOT Dump Truck and PLS Military-Vehicle (Patrick County Bridge)

Dynamic Load Allowance

The dynamic load allowance can be calculated by dividing the largest deflection for a dynamic truck crossing by the average of the maximum deflections for all of the static truck crossings for the same girder. These static and dynamic deflections must be obtained with the truck crossing the bridge in the same transverse location in order to give an accurate measure of the dynamic load allowance. The dynamic load allowance was computed under the same assumptions used to compute live load distribution factors.

Dynamic Load Allowance, Franklin County Bridge

Table 13 presents a summary of the calculated dynamic load allowances for the VDOT dump truck and the U.S. Army PLS truck. Figure 30 illustrates the dynamic load allowance for the two trucks and the values for dynamic load allowance specified by the AASHTO Standard Specification and AASHTO LRFD. The maximum dynamic load allowance (for truck crossings of similar transverse orientation) for the most heavily loaded girder was plotted in this figure.

Table 13
Summary of Dynamic Load Allowances (Franklin County Bridge)

Truck Orientation	Dynamic Load Allowance (%)					Maximum
	1 st Crossing	2 nd Crossing	3 rd Crossing	4 th Crossing	5 th Crossing	
DR	1	1	1.0	7	7	7
PR	-5	-5	-12	-20	-	-5
DC	21	21	12	-	-	21
PC	11	15	7	7	-	15
DL	9	17	6	12	20	20
PL	-23	-19	-16	-	-	-16

DR = Dump Truck Over Right Exterior Girder
 DC = Dump Truck Centered Between Interior Girders
 PR = PLS Truck Over Right Exterior Girder
 PC = PLS Truck Centered Between Interior Girders
 DL = Dump Truck Over Left Exterior Girder
 PL = PLS Truck Over Left Exterior Girder

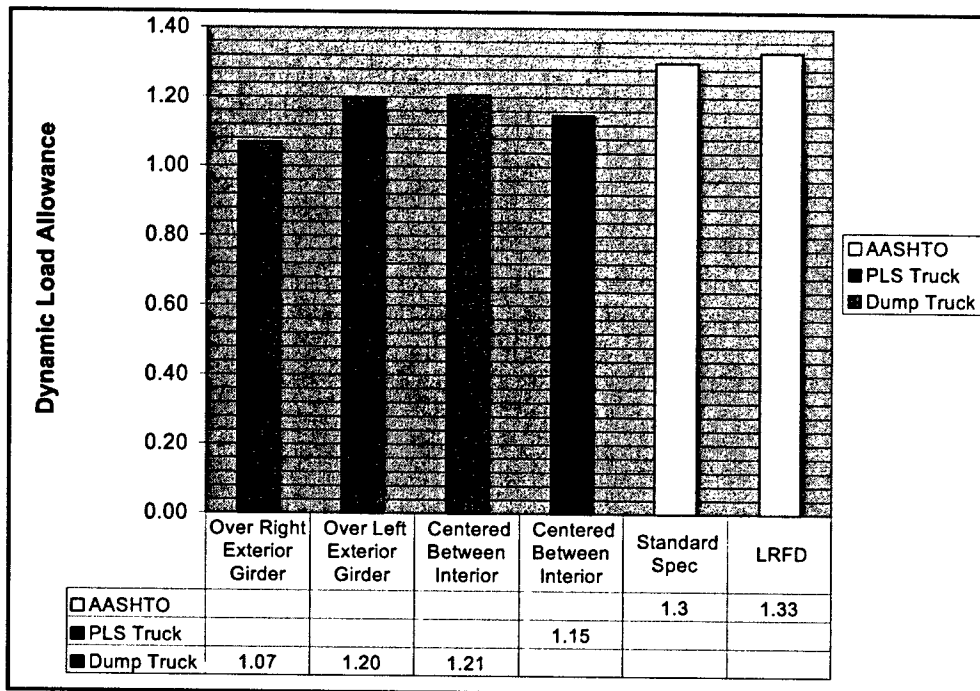

Figure 30. Dynamic Load Allowance for Franklin County Bridge

Dynamic Load Allowance, Patrick County Bridge

Table 14 presents a summary of the calculated dynamic load allowances for the VDOT dump truck and the U.S. Army PLS truck. Figure 31 illustrates the dynamic load allowance for the two trucks and the values for dynamic load allowance specified by the AASHTO Standard Specification and AASHTO LRFD. The maximum dynamic load allowance (for truck crossings of similar transverse orientation) for the most heavily loaded girder was plotted in this figure.

Truck Orientation	Dynamic Load Allowance (%)					Maximum
	1 st Crossing	2 nd Crossing	3 rd Crossing	4 th Crossing	5 th Crossing	
DR	0	-2	-2	14	5	14
PR	-4	-	-	-	-	-4
DC	21	21	21	-	-	21
PC	42	33	46	33	-	46
DL	29	21	19	11	14	29
PL	5	-	-	--	-	5

DR	=	Dump Truck One Foot From Right Curb
DC	=	Dump Truck Centered Between Interior Girders
PR	=	PLS Truck One Foot From Right Curb
PC	=	PLS Truck Centered Between Interior Girders
DL	=	Dump Truck One Foot From Left Curb
PL	=	PLS Truck One Foot From Left Curb

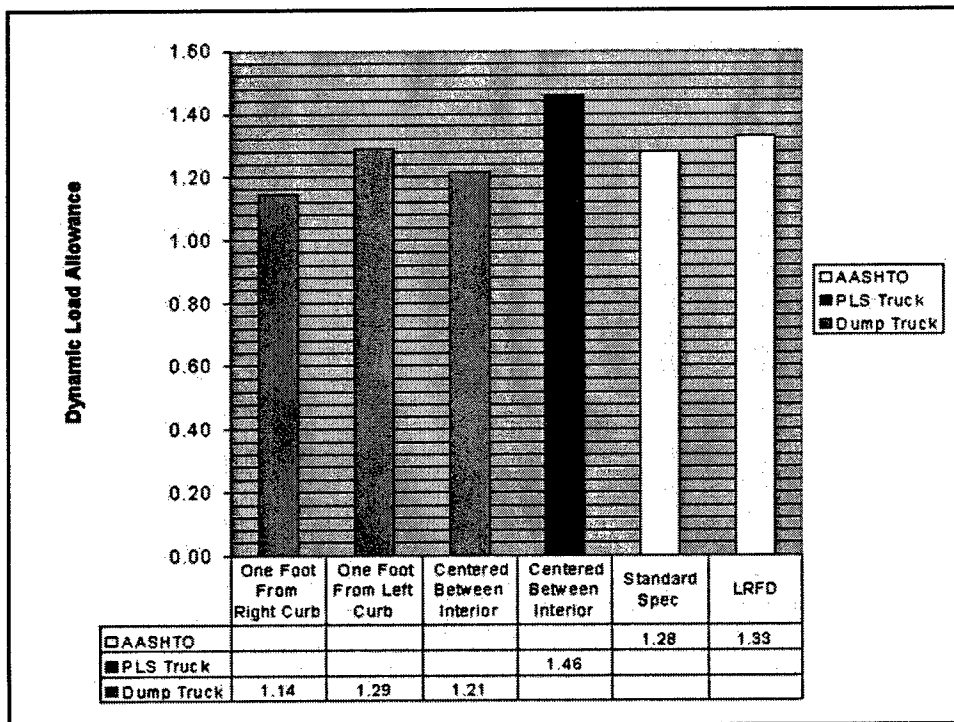

Figure 31. Dynamic Load Allowance for Patrick County Bridge

4 Discussion, Conclusions, and Recommendations.

Discussion of Measured Deflections

There was a very close correlation between measured deflections for truck crossings of similar transverse position and speed (Tables 4, 5, 7, and 8). Because of this and the fact that the deflectometers were carefully calibrated before testing, it suggests that the measured deflections were both accurate and precise. However, there was a large variation in beam deflection with respect to time for three of the truck crossings (static loading of the Patrick County Bridge with the dump truck centered between interior girders). This fluctuation can be attributed to noise in the deflectometer signals (Figures 19 and 23).

Interestingly, the field-measured deflections were between 20 and 25 percent of the values calculated using the AASHTO Standard Specification (Appendix B for AASHTO values). This most likely can be attributed to three factors. First, composite action exists between the parapets and the T-beams, which significantly increases the moment of inertia (and stiffness of the T-beams). Secondly, the bearings may be prohibiting free rotation of the T-beam ends. This also increases the stiffness of the T-beams and decreases the positive mid-span moment by distributing some of this moment towards the supports in the form of negative moment. This effect (bearings behaving as fixed supports) would account for approximately a 25 percent decrease in deflections. However, it is unlikely that the bearings are completely restricting rotation. Finally, the deflections computed as per the AASHTO Standard Specification assumed a concrete compressive strength of 4,000 psi. After time the concrete has exhibited a gain in compressive strength and modulus of elasticity, once again increasing the stiffness.

Conclusions

Lateral Live Load Distribution Factors

Since there was a very close correlation between measured deflections for similar truck crossings, there was also excellent agreement between computed distribution factors for similar truck crossings. Due to this and careful attention to detail and precision during the test preparation and testing procedure, the experimentally determined distribution factors are believed to be an excellent representation of "reality."

Figure 26 (Franklin County Bridge) and Figure 29 (Patrick County Bridge) show that the interior and exterior girder distribution factors for the VDOT dump truck and U.S. Army PLS truck are very similar. Further inspection of these tables show that the distribution factor for the PLS truck was at most 7 percent less than the distribution factor for the dump truck and never more than 9 percent greater than the distribution factor for the dump truck. From this, it can be concluded that differences in axle configuration, weight distribution, and tire contact area for the PLS truck do not significantly influence the lateral live load distribution factor.

Tables 9 and 11 (dump truck) and Tables 10 and 12 (PLS truck) illustrate the fact that the actual distribution factors for the VDOT dump truck and the U.S. Army PLS truck are always smaller than the distribution factor calculated as per the AASHTO Standard Specification or AASHTO LRFD. The distribution factors for the both the VDOT dump truck and the U.S. Army PLS truck were as much as 46 percent smaller than the AASHTO Standard Specification value and 40 percent smaller than the AASHTO LRFD value. (In both instances this occurred for the distribution factor for interior girders with one lane loaded.)

Dynamic Load Allowance

The calculated dynamic load allowance for the PLS truck was slightly smaller than the dynamic load allowance for the dump truck on the Franklin County bridge (Figure 30). However, the dynamic load allowance for the PLS truck was significantly larger than the respective value for the dump truck on the Patrick County bridge (Figure 31). Because of the size of the PLS truck and the alignment and geometry of the bridges, the PLS truck was unable to accurately drive over the exterior girders at high speeds. Therefore, the computed dynamic load allowances for the exterior girders (truck crossings with a wheel line over an exterior girder) were not representative of the actual dynamic load allowance (Tables 13 and 14).

The PLS truck produced a dynamic load effect significantly smaller than the AASHTO values on the Franklin County bridge. However, the AASHTO values were unconservatively smaller than those computed for the PLS truck on the Patrick County Bridge. An accurate measure of the dynamic load allowance was unable to be obtained due to the difficulty in controlling the transverse positioning of the PLS truck on the bridge deck. Also differences in the condition of the two bridge decks, deck joints, and approach slabs made it nearly

impossible to draw any definite conclusions regarding the dynamic load allowance.

Recommendations

Lateral Live Load Distribution Factor

It is recommended that the AASHTO distribution factors be used as a conservative means of load rating reinforced concrete T-beam bridges for loading due to a VDOT dump truck or a U.S. Army PLS truck. If this analysis shows that either truck slightly over stresses the bridge, a more accurate and liberal value for the distribution factor may be obtained by field testing the bridge. Testing of additional reinforced concrete T-beam bridges is advisable to gain a more representative measure of the lateral live load distribution factors.

Dynamic Load Allowance

Whether or not the AASHTO Standard Specification or AASTHO LRFD values for dynamic load allowance can be used as a conservative means to load rate a reinforced concrete T-beam bridge is unclear at this point. It is suggested that more research be conducted to study the dynamic load allowance for both the VDOT dump truck and the U.S. Army PLS truck. All of the parameters that influence the dynamic load allowance, including the speed of the vehicle, the stiffness of the vehicle's suspension, the mass and stiffness of the bridge (fundamental frequency), and the condition of the deck surface, deck joints, and approach slabs need to be individually examined.

References

- American Association of State Highway and Transportation Officials. (1996). "Standard Specification for Highway Bridges," 16th ed., American Association of State Highway and Transportation Officials, Washington, DC.
- American Association of State Highway and Transportation Officials. (1998). "LRFD Bridge Design Specification," 2nd ed., American Association of State Highway and Transportation Officials, Washington, DC.
- Barker, R.M. and J.A. Puckett. (1997). "Design of Highway Bridges," John Wiley & Sons, Inc., New York, NY, pp. 24, 275-331.
- VDOT. (1947). "Proposed Bridge Drawings, Bridge on Rte. 40 Over Little Widgeon Creek, Patrick County," Commonwealth of Virginia Department of Highways, Project: 1403.
- VDOT. (1979). "Proposed Bridge Drawings, Bridge on Rte. 697 Over Mill Creek, Franklin County," Commonwealth of Virginia Department of Highways and Transportation, Project: 697-033-160, B628.

Appendix A

Calculation of AASHTO Distribution Factors and Dynamic Load Allowance

Franklin County Bridge:

- **Load Distribution Factor for Moment - Interior Beam (AASHTO Standard Specifications)**

One Lane Loaded:

$S=7.0 \text{ ft} > 6.0 \text{ ft} \rightarrow$ Use the Lever Rule.

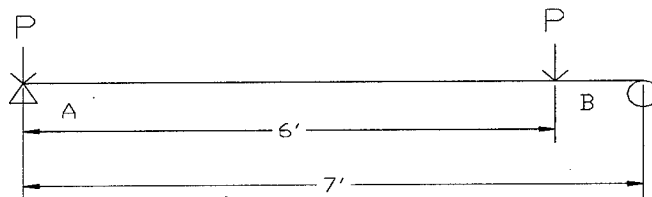

$$\Sigma M_B = 7P + P - 7R_A = 0$$

$$R_A = 1.14 \text{ wheel lines / beam} = 0.57 \text{ axles / beam}$$

Two Lanes Loaded:

$$S/6.0 = 7.0/6.0 = 1.17/2 = 0.59 \text{ axles / beam}$$

- **Load Distribution Factor for Moment - Interior Beam (AASHTO LRFD Bridge Design Specifications)**

One Lane Loaded:

$$0.06+(S/14)^{0.4}(S/L)^{0.3}(K_g/12.0L_t^3)^{0.1}$$

$$K_g = n(I+Ae_g^2) ; n = 1$$

$$I = bh^3/12 = 32805 \text{ in.}^4$$

$$A = bh = 540 \text{ in.}^2$$

$$e_g = 17.5 \text{ in.}$$

$$K_g = 1(32805+(540)(17.5)^2) = 198180$$

$$0.06+(7.0/14)^{0.4}(7.0/40.0)^{0.3}(198180/(12.0)(40)(8)^3)^{0.1} = 0.5 \text{ axles/beam}$$

Two Lanes Loaded:

$$0.075+(S/9.5)^{0.6}(S/L)^{0.2}(K_g/12.0L_t^3)^{0.1}$$

$$0.075+(7.0/9.5)^{0.6}(7.0/40.0)^{0.2}(198180/(12.0)(40)(8)^3)^{0.1} = 0.65 \text{ axles/beam}$$

- **Load Distribution Factor for Moment - Exterior Beam (AASHTO Standard Specifications)**

One or Two Lanes Loaded:

Use the Lever Rule with first wheel load positioned at 1 ft from parapet.

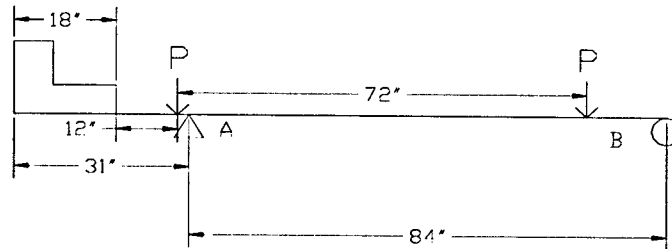

$$\Sigma M_B = 85P + 13P - 84R_A = 0$$

$$R_A = 1.17 \text{ wheel lines / beam} = 0.59 \text{ axles/beam}$$

- **Load Distribution Factor for Moment - Exterior Beam (AASHTO LRFD Bridge Design Specifications)**

One Lane Loaded:

0.59 axles/beam (same as AASHTO Standard Specifications)

Two Lanes Loaded:

$$g = e g_{\text{interior}}$$

$$e = 0.77 + d_e / 9.1 = 0.77 + 0.25 / 9.1 = 0.797$$

$$d_e = 0.25 \text{ ft}$$

$$g = (0.797)(0.65 \text{ axles /beam}) = 0.518 \text{ axles/beam}$$

- **Dynamic Load Allowance Factor (AASHTO Standard Specifications)**

$$I = 50 / (L + 125) = 50 / (40 + 125) = 0.303$$

- **Dynamic Load Allowance Factor (AASHTO LRFD Bridge Design Specification)**

$$I = 0.333$$

Patrick County Bridge:

- **Load Distribution Factor for Moment - Interior Beam (AASHTO Standard Specifications)**

One Lane Loaded:

$S = 8.17 \text{ ft} > 6.0 \text{ ft} \rightarrow$ Use the Lever Rule.

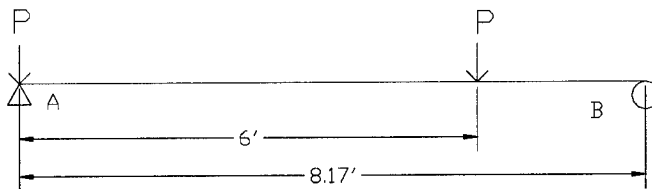

$$\Sigma M_B = 8.17P + 2.17P - 8.17R_A = 0$$

$$R_A = 1.27 \text{ wheel lines / beam} = 0.63 \text{ axles/beam}$$

Two Lanes Loaded:

$$S/6.0 = 8.17/6.0 = 1.362/2 = 0.68 \text{ axles/beam}$$

- **Load Distribution Factor for Moment - Interior Beam (AASHTO LRFD Bridge Design Specifications)**

One Lane Loaded:

$$0.06 + (S/14)^{0.4} (S/L)^{0.3} (K_g/12.0L_t^3)^{0.1}$$

$$K_g = n(I + Ae_g^2) ; n = 1$$

$$I = bh^3/12 = 121546 \text{ in.}^4$$

$$A = bh = 807.5 \text{ in.}^2$$

$$e_g = 25.0 \text{ in.}$$

$$K_g = 1(121546 + (807.5)(25.0)^2) = 626234$$

$$0.06 + (8.17/14)^{0.4} (8.17/51.125)^{0.3} (626234/(12.0)(51.125)(7.5)^3)^{0.1} = 0.57 \text{ axles/beam}$$

Two Lanes Loaded:

$$0.075 + (S/9.5)^{0.6} (S/L)^{0.2} (K_g/12.0L_t^3)^{0.1}$$

$$0.075 + (8.17/9.5)^{0.6} (8.17/51.125)^{0.2} (626234/(12.0)(51.125)(7.5)^3)^{0.1} = 0.77 \text{ axles/beam}$$

- **Load Distribution Factor for Moment - Exterior Beam (AASHTO Standard Specifications)**

One or Two Lanes Loaded:

Use the Lever Rule with first wheel load positioned at 1 ft from parapet.

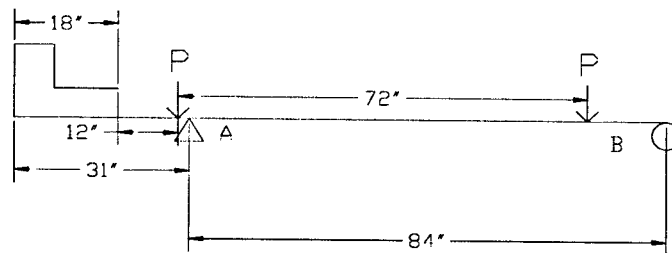

$$\Sigma M_B = 93P + 21P - 96.5R_A = 0$$

$$R_A = 1.18 \text{ wheel lines / beam} = 0.59 \text{ axles/beam}$$

- **Load Distribution Factor for Moment - Exterior Beam (AASHTO LRFD Bridge Design Specifications)**

One Lane Loaded:

0.59 axles/beam (same as AASHTO Standard Specifications)

Two Lanes Loaded:

$$g = e g_{\text{interior}}$$

$$e = 0.77 + d_e / 9.1 = 0.77 + 0 / 9.1 = 0.77$$

$$d_e = 0 \text{ ft}$$

$$g = (0.77)(0.77 \text{ axles / beam}) = 0.590 \text{ axles/beam}$$

- **Dynamic Load Allowance Factor (AASHTO Standard Specifications)**

$$I = 50 / (L + 125) = 50 / (51.125 + 125) = 0.284$$

- **Dynamic Load Allowance Factor (AASHTO LRFD Bridge Design Specification)**

$$I = 0.333$$

- Notes:**
- 1) All bridge dimensions used in this appendix were obtained from original bridge drawings (VDOT 1947 and VDOT 1979).
 - 2) All terms have been previously defined in Table 1.

Appendix B

Pretest Analysis for Estimation of Deflections

Franklin County Bridge:

- **Effective Flange Width:**

$$b_e = \min(1/4 \text{ span length, } 12 * \text{slab thickness, beam spacing}) = \min(120 \text{ in., } 96 \text{ in., } 84 \text{ in.})$$
$$b_e = 84 \text{ in.}$$

- **Steel Reinforcement Area:**

Assume: $f'_c = 4000 \text{ ksi}$, $E_c = 3605 \text{ ksi}$:

$$\eta = E_s/E_c = 29000 \text{ ksi} / (57(4000 \text{ ksi})^{1/2}) = 8$$

$$A_s = (10)(1.23 \text{ in.}^2) = 12.27 \text{ in.}^2$$

(10 - #10 bars)

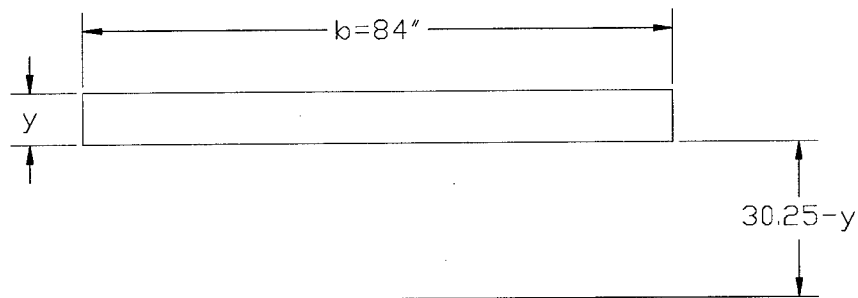

$$\eta A_s = 98.16 \text{ in}^2$$

Cracked Moment of Inertia:

$$84y(y/2) = (30.25 - y) 98.16$$

$$42y^2 = 2969.34 - 98.16y$$

$$y = 7.3 \text{ in.}$$

$$I_{cr} = (84)(7.3)^3/12 + (84)(7.3)(7.3/2)^2 + (98.16)(30.25 - 7.3)^2$$

$$I_{cr} = 62482 \text{ in.}^4$$

- **Gross Moment of Inertia:**

$$y_{cg} = [(8)(84)(31) + (20)(27)(13.5)] / [(8)(84) + (20)(27)]$$

$$y_{cg} = 23.2 \text{ in.}$$

$$I_g = (84)(8)^3/12 + (84)(8)(31 - 23.2)^2 + (20)(27)^3/12 + (20)(27)(23.2 - 13.5)^2$$

$$I_g = 128082 \text{ in.}^4$$

- **Load Distribution Factor for Moment (AASHTO Standard Specifications)**

Interior Beam - Two Lanes Loaded: $S/6.0 = (7/6.0)/2 = 0.585$
axles/beam

Exterior Beam - Two Lanes Loaded: Use the Lever Rule with first wheel load positioned at 1 ft from parapet.

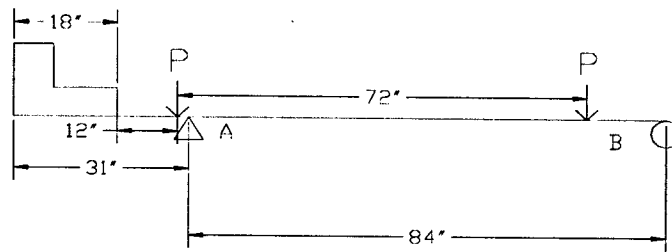

$$\Sigma M_B = 85P + 13P - 84R_A = 0$$

$$R_A = 1.17 \text{ wheel lines / beam} = 0.585 \text{ axles/beam}$$

- **Dynamic Load Allowance Factor (AASHTO Standard Specifications)**

$$I = 50/(L+125) = 50/(40+125) = 0.303$$

- **VDOT Dump Truck Axle Spacing and Weights**

Apply load distribution factor and dynamic load allowance factor:

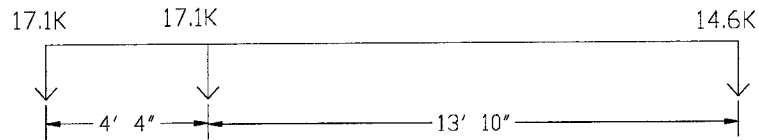

$$P = (17.1K)(0.585)(1.303) = 13.0 \text{ kips}$$

$$P = (14.6K)(0.585)(1.303) = 11.1 \text{ kips}$$

Place loads to produce M_{\max} :

$$x = [(13K)(4.33 \text{ ft}) + (11.1K)(18.2 \text{ ft})] / 37.1K$$

$$x = 6.95 \text{ ft}$$

$$L_1 = 6.95 \text{ ft} - 4.33 \text{ ft} = 2.62 \text{ ft}$$

$$X = L/2 - L_1/2 = 20 \text{ ft} - 1.31 \text{ ft} = 18.69 \text{ ft}$$

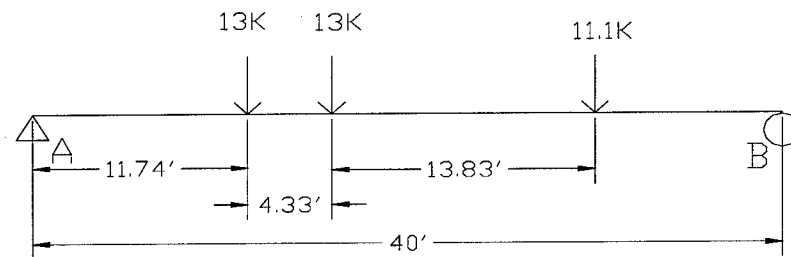

$$R_B = [(11.74 \text{ ft})(13K) + (16.07 \text{ ft})(13K) + (29.9 \text{ ft})(11.1K)] / 40 \text{ ft}$$

$$R_B = 17.3 \text{ kips}$$

$$R_A = 37.1K - 17.3K = 19.8 \text{ kips}$$

- **Effective Moment of Inertia:**

$$I_e = (M_{cr} / M_a)^3 I_g + (1 - (M_{cr} / M_a)^3) I_{cr}, \text{ where } M_a = M_{\max}$$

$$M_{\max} = (17.3K)(23.93 \text{ ft}) - (13K)(13.83 \text{ ft}) = 234 \text{ K}\cdot\text{ft} = 2810 \text{ K}\cdot\text{in.}$$

$$M_{cr} = f_r I_g / y_{cg}$$

$$f_r = 7.5(4000)^{1/2} = 474 \text{ psi}$$

$$M_{cr} = 2617 \text{ kip}\cdot\text{in.}$$

$$I_e = (M_{cr}/M_a)^3 I_g + (1 - (M_{cr}/M_a)^3) I_{cr}$$

$$I_e = (2617/2810)^3 (128082) + (1 - (2617/2810)^3) (62482) = 115472 \text{ in.}^4$$

- **Midspan Deflection for Maximum Moment:**

Find the midspan deflection due to each load with the truck oriented to produce the maximum moment. Use superposition to find the total deflection.

For $L = 480 \text{ in.}$, $x = 240 \text{ in.}$, $E = 3605 \text{ ksi}$, $I_e = 115472 \text{ in.}^4$

$$\delta_{\text{midspan}} = [Pbx/6EI_e L] (L^2 - b^2 - x^2)$$

$$\delta_{\text{midspan}} = [240Pb/1.199 \times 10^{12}] (172800 - b^2)$$

where $P = \text{axle load}$, $b = \text{distance from load to far end of beam}$

For $P = 13.0 \text{ kips}$, $b = 11.74 \text{ ft} = 141 \text{ in.}$, $\delta_{\text{midspan}} = 0.056 \text{ in.}$

For $P = 13.0 \text{ kips}$, $b = 16.07 \text{ ft} = 193 \text{ in.}$, $\delta_{\text{midspan}} = 0.068 \text{ in.}$

For $P = 11.1 \text{ kips}$, $b = 10.1 \text{ ft} = 121 \text{ in.}$, $\delta_{\text{midspan}} = 0.043 \text{ in.}$

Total $\delta_{\text{midspan}} = 0.167 \text{ in.}$

Patrick County Bridge:

A) Exterior Girders:

- **Effective Flange Width:**

$$b_e = 9.5 \text{ in.} + 16 \text{ in.} + 79 \text{ in.}/2 = 65 \text{ in.}$$

- **Steel Reinforcement Area:**

Assume: $f_c = 4000 \text{ ksi}$, $E_c = 3605 \text{ ksi}$:

$$\eta = E_s/E_c = 29000 \text{ ksi} / (57(4000 \text{ ksi})^{1/2}) = 8$$

$$A_s = 13.25 \text{ in.}^2$$

(10 – 1 1/8 in. square bars, 2 – 1 in. square bars)

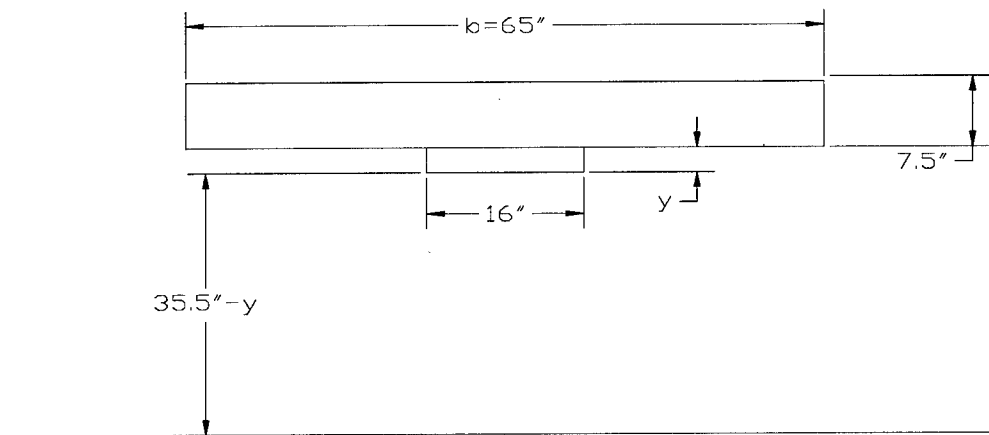

$$\eta A_s = 106 \text{ in}^2$$

- **Cracked Moment of Inertia:**

$$(65)(7.5)(7.5/2+y) + 16y(y/2) = (35.5-y)106$$

$$1828.13 + 487.5y + 8y^2 = 3763 - 106y$$

$$8y^2 + 593.5y = 1934.87$$

$$y = 3.1 \text{ in.}$$

$$I_{cr} = (65)(7.5)^3/12 + (65)(7.5)(6.85)^2$$

$$+ (16)(3.1)^3/12 + (16)(3.1)(1.55)^2 + (106)(35.5-3.1)^2$$

$$I_{cr} = 136593 \text{ in.}^4$$

- **Gross Moment of Inertia:**

$$y_{cg} = [(65)(7.5)(45.25) + (41.5)(16)(20.75)] / [(65)(7.5) + (41.5)(16)]$$

$$y_{cg} = 31.12 \text{ in.}$$

$$I_g = (65)(7.5)^3/12 + (65)(7.5)(14.13)^2 + (16)(41.5)^3/12 + (16)(41.5)(10.37)^2$$

$$I_g = 266320 \text{ in.}^4$$

- **Load Distribution Factor for Moment (AASHTO Standard Specifications)**

Exterior Beam - Two Lanes Loaded: Use the Lever Rule with first wheel load positioned at 1 ft from parapet.

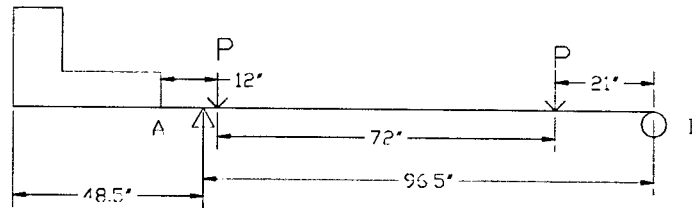

$$\Sigma M_B = 93P + 21P - 96.5R_A = 0$$

$$R_A = 1.18 \text{ wheel lines / beam} = 0.59 \text{ axles/beam}$$

- **Dynamic Load Allowance Factor (AASHTO Standard Specifications)**

$$I = 50 / (L + 125) = 0.277$$

- **VDOT Dump Truck Axle Spacing and Weights**

Apply load distribution factor and dynamic load allowance factor:

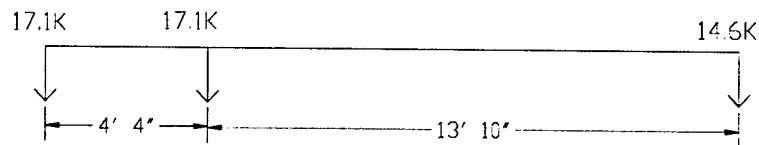

$$P = (17.1K)(0.59)(1.277) = 12.9 \text{ kips}$$

$$P = (14.6K)(0.59)(1.277) = 11.0 \text{ kips}$$

Place loads to produce M_{\max} :

$$x = [(12.9K)(4.33 \text{ ft}) + (11.0K)(18.2 \text{ ft})] / 36.8K$$

$$x = 6.95 \text{ ft}$$

$$L_1 = 6.95 \text{ ft} - 4.33 \text{ ft} = 2.62 \text{ ft}$$

$$X = L/2 - L_1/2 = 55.75 \text{ ft} / 2 - 2.62 \text{ ft} / 2 = 26.57 \text{ ft}$$

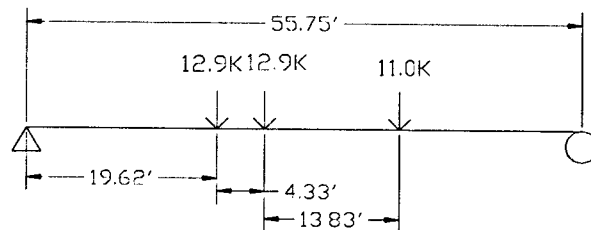

$$R_B = [(19.62 \text{ ft})(12.9\text{K})+(23.95 \text{ ft})(12.9\text{K})+(37.78 \text{ ft})(11.0\text{K})]/55.75 \text{ ft}$$

$$R_B = 17.54 \text{ kips}$$

- **Effective Moment of Inertia:**

$$I_e = (M_{cr}/M_a)^3 I_g + (1 - (M_{cr}/M_a)^3) I_{cr}, \text{ where } M_a = M_{\max}$$

$$M_{\max} = (17.5\text{K})(31.8 \text{ ft}) - (11.0\text{K})(13.83 \text{ ft}) = 404.4 \text{ K}\cdot\text{ft} = 4852 \text{ kip}\cdot\text{in.}$$

$$M_{cr} = f_r I_g / y_{cg}$$

$$f_r = 7.5(4000)^{1/2} = 474 \text{ psi}$$

$$M_{cr} = 4056 \text{ k}\cdot\text{in.}$$

$$I_e = (M_{cr}/M_a)^3 I_g + (1 - (M_{cr}/M_a)^3) I_{cr}$$

$$I_e = (4056/4852)^3 (266320) + (1 - (4056/4852)^3) (136593) = 212374 \text{ in.}^4$$

- **Midspan Deflection for Maximum Moment:**

Find the midspan deflection due to each load with the truck oriented to produce the maximum moment. Use superposition to find the total deflection.

$$\text{For } L = 669 \text{ in., } x = 334.5 \text{ in., } E = 3605 \text{ ksi, } I_e = 212374 \text{ in.}^4$$

$$\delta_{\text{midspan}} = [Pbx/6EI_e L] (L^2 - b^2 - x^2)$$

$$\delta_{\text{midspan}} = [334.5Pb/3.073 \cdot 10^{12}] (335671 - b^2)$$

where P = axle load, b = distance from load to far end of beam

$$P = 12.9 \text{ kips, } b = 19.62 \text{ ft} = 235 \text{ in., } \delta_{\text{midspan}} = 0.093 \text{ in.}$$

$$P = 12.9 \text{ kips, } b = 23.95 \text{ ft} = 287 \text{ in., } \delta_{\text{midspan}} = 0.102 \text{ in.}$$

$$P = 11.0 \text{ kips, } b = 17.97 \text{ ft} = 216 \text{ in., } \delta_{\text{midspan}} = 0.075 \text{ in.}$$

$$\text{Total } \delta_{\text{midspan}} = 0.270 \text{ in.}$$

B) Interior Girders:

- **Effective Flange Width:**

$$b_e = \min(1/4 \text{ span length, } 12 \cdot \text{slab thickness, beam spacing}) =$$

$$\min(167.25 \text{ in., } 90 \text{ in., } 97 \text{ in.})$$

$$b_e = 90 \text{ in.}$$

- **Steel Reinforcement Area:**

Assume: $f'_c = 4000$ ksi, $E_c = 3605$ ksi:

$$\eta = E_s/E_c = 29000 \text{ ksi} / (57(4000 \text{ ksi})^{1/2}) = 8$$

$$A_s = 18.188 \text{ in.}^2$$

(12 – 1 1/8 in. square bars, 3 – 1 in. square bars)

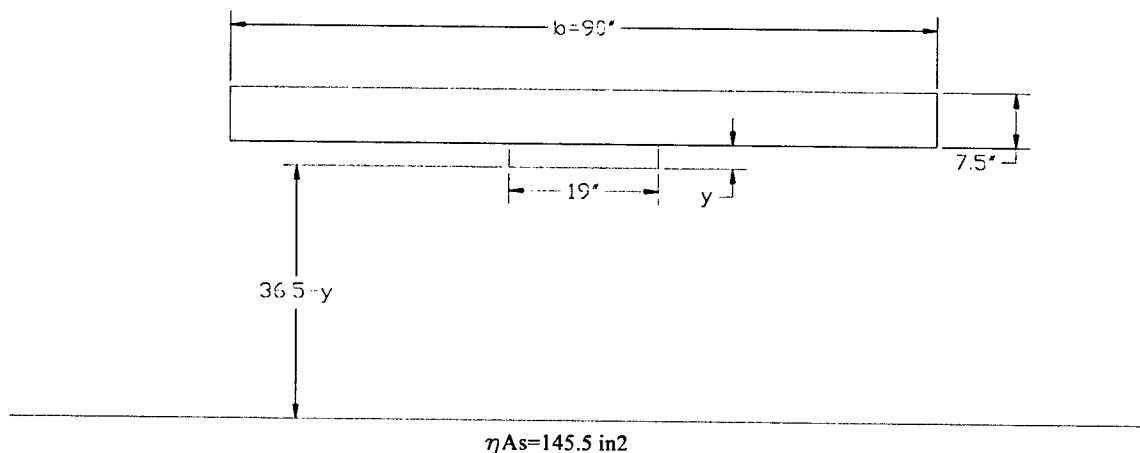

- **Cracked Moment of Inertia:**

$$(90)(7.5)(7.5/2+y)+19y(y/2) = (35.5-y)145.5$$

$$2531.25+675y+9.5 y^2 = 5310.75-145.5y$$

$$9.5y^2 +820.5y = 2779.5$$

$$y = 3.26 \text{ in.}$$

$$I_{cr} =$$

$$(90)(7.5)^3/12+(90)(7.5)(3.26+3.75)^2+(19)(3.26)^3/12+(19)(3.26)(1.63)^2$$

$$+(145.5)(36.5-3.26)^2$$

$$I_{cr} = 197316 \text{ in.}^4$$

- **Gross Moment of Inertia:**

$$y_{cg} = [(90)(7.5)(46.25)+(42.5)(19)(21.25)]/[(90)(7.5)+(42.5)(19)]$$

$$y_{cg} = 32.63 \text{ in.}$$

$$I_g = (90)(7.5)^3/12+(90)(7.5)(13.62)^2+(19)(42.5)^3/12+(19)(42.5)(11.38)^2$$

$$I_g = 354500 \text{ in.}^4$$

- **Load Distribution Factor for Moment (AASHTO Standard Specifications)**

Interior Beam - Two Lanes Loaded: $S/6.0 = (8.17/6.0)/2 = 0.681$
axles/beam

- **Dynamic Load Allowance Factor (AASHTO Standard Specifications)**

$$I = 50 / (L + 125) = 0.277$$

- **VDOT Dump Truck Axle Spacing and Weights**

Apply load distribution factor and dynamic load allowance factor:

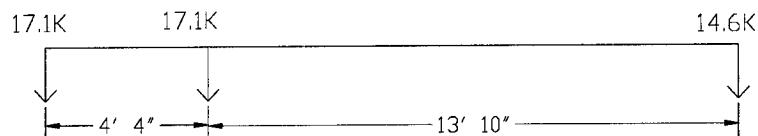

$$P = (17.1K)(0.681)(1.277) = 14.9K$$

$$P = (14.6K)(0.681)(1.277) = 12.7K$$

Place loads to produce M_{max} :

$$x = [(12.9K)(4.33 \text{ ft}) + (11.0K)(18.2 \text{ ft})] / 36.8K$$

$$x = 6.95 \text{ ft}$$

$$L_1 = 6.95 \text{ ft} - 4.33 \text{ ft} = 2.62 \text{ ft}$$

$$X = L/2 - L_1/2 = 55.75 \text{ ft}/2 - 2.62 \text{ ft}/2 = 26.57 \text{ ft}$$

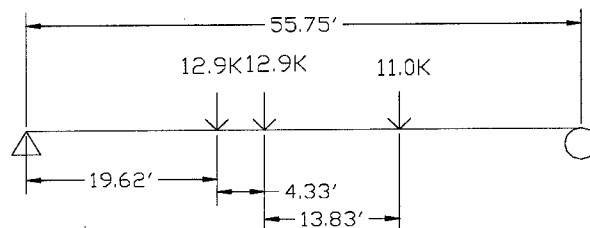

$$R_B = [(19.62 \text{ ft})(14.9K) + (23.95 \text{ ft})(14.9K) + (37.78 \text{ ft})(12.7K)] / 55.75 \text{ ft}$$

$$R_B = 20.25 \text{ kip}$$

- **Effective Moment of Inertia:**

$$I_e = (M_{cr}/M_a)^3 I_g + (1 - (M_{cr}/M_a)^3) I_{cr}, \text{ where } M_a = M_{max}$$

$$M_{max} = (20.25K)(31.8 \text{ ft}) - (12.7K)(13.83 \text{ ft}) = 468 \text{ K}\cdot\text{ft} = 5620 \text{ kip}\cdot\text{in.}$$

$$M_{cr} = f_r I_g / y_{cg}$$

$$f_r = 7.5(4000)^{1/2} = 474 \text{ psi}$$

$$M_{cr} = 5150 \text{ k}\cdot\text{in.}$$

$$I_e = (M_{cr}/M_a)^3 I_g + (1 - (M_{cr}/M_a)^3) I_{cr}$$

$$I_e = (5150/5620)^3 (354500) + (1 - (5150/5620)^3) (197316) = 318270 \text{ in.}^4$$

- **Midspan Deflection for Maximum Moment:**

Find the midspan deflection due to each load with the truck oriented to produce the maximum moment. Use superposition to find the total deflection.

$$\text{For } L = 669 \text{ in.}, x = 334.5 \text{ in.}, E = 3605 \text{ ksi}, I_e = 318270 \text{ in.}^4$$

$$\delta_{\text{midspan}} = [Pbx/6EI_e L] (L^2 - b^2 - x^2)$$

$$\delta_{\text{midspan}} = [334.5Pb/4.606 \cdot 10^{12}] (335671 - b^2)$$

where P = axle load, b = distance from load to far end of beam

$$P = 14.9 \text{ kips}, b = 19.62 \text{ ft} = 235 \text{ in.}, \delta_{\text{midspan}} = 0.071 \text{ in.}$$

$$P = 14.9 \text{ kips}, b = 23.95 \text{ ft} = 287 \text{ in.}, \delta_{\text{midspan}} = 0.079 \text{ in.}$$

$$P = 12.7 \text{ kips}, b = 17.97 \text{ ft} = 216 \text{ in.}, \delta_{\text{midspan}} = 0.058 \text{ in.}$$

$$\text{Total } \delta_{\text{midspan}} = 0.208 \text{ in.}$$

- Notes:**
- 1) All bridge dimensions used in this appendix were obtained from original bridge drawings (VDOT 1947 and VDOT 1979).
 - 2) All terms are defined in AASHTO Standard Specification (AASHTO 1996).
 - 3) Calculations represent pre-test deflection estimates due to two VDOT dump trucks loading.

REPORT DOCUMENTATION PAGE

Form Approved
OMB No. 0704-0188

Public reporting burden for this collection of information is estimated to average 1 hour per response, including the time for reviewing instructions, searching existing data sources, gathering and maintaining the data needed, and completing and reviewing this collection of information. Send comments regarding this burden estimate or any other aspect of this collection of information, including suggestions for reducing this burden to Department of Defense, Washington Headquarters Services, Directorate for Information Operations and Reports (0704-0188), 1215 Jefferson Davis Highway, Suite 1204, Arlington, VA 22202-4302. Respondents should be aware that notwithstanding any other provision of law, no person shall be subject to any penalty for failing to comply with a collection of information if it does not display a currently valid OMB control number. **PLEASE DO NOT RETURN YOUR FORM TO THE ABOVE ADDRESS.**

1. REPORT DATE (DD-MM-YYYY) August 2003	2. REPORT TYPE Final report	3. DATES COVERED (From - To)
---------------------------------------------------	---------------------------------------	-------------------------------------

4. TITLE AND SUBTITLE Field Study of Live Load Distribution Factors and Dynamic Load Allowance on Reinforced Concrete T-Beam Bridges	5a. CONTRACT NUMBER
	5b. GRANT NUMBER
	5c. PROGRAM ELEMENT NUMBER

6. AUTHOR(S) Matthew D. Trimble, Thomas E. Cousins, Yazmin Seda-Sanabria	5d. PROJECT NUMBER
	5e. TASK NUMBER
	5f. WORK UNIT NUMBER TE004

7. PERFORMING ORGANIZATION NAME(S) AND ADDRESS(ES) Virginia Polytechnic Institute and State University Blacksburg, VA 24061; U.S. Army Engineer Research and Development Center Geotechnical and Structures Laboratory 3909 Halls Ferry Road Vicksburg, MS 39180-6199	8. PERFORMING ORGANIZATION REPORT NUMBER ERDC/GSL TR-03-11
--------------------------------------------------------------------------------------------------------------------------------------------------------------------------------------------------------------------------------------------------------------------------------------------------------	--------------------------------------------------------------------------

9. SPONSORING / MONITORING AGENCY NAME(S) AND ADDRESS(ES) U.S. Army Corps of Engineers Washington, DC 20314-1000	10. SPONSOR/MONITOR'S ACRONYM(S)
	11. SPONSOR/MONITOR'S REPORT NUMBER(S)

12. DISTRIBUTION / AVAILABILITY STATEMENT

Approved for public release; distribution is unlimited.

13. SUPPLEMENTARY NOTES

14. ABSTRACT

This study focuses on the evaluation of live load distribution and dynamic load allowance factors for reinforced concrete T-beam bridges subject to heavy military-vehicle loading. Field displacement measurements on actual bridges were incorporated as part of the evaluation procedure. The vehicle under consideration in this study was a U.S. Army Palletized Loading System (PLS) military vehicle. Results from this evaluation were compared to those obtained from a civilian dump truck owned by the Virginia Department of Transportation (VDOT). The comparative evaluation also considered the design guidelines presented in the American Association of State Highway and Transportation Officials (AASHTO) Standard Specifications for Highways Bridges and the AASHTO Load Resistance Factor Design (LRFD) Bridge Design Specifications.

Two typical cast-in-place reinforced concrete T-beam bridges were selected for field testing with the vehicle under various transverse position scenarios. It was concluded that there was not an appreciable difference in the load distribution factors obtained from the PLS truck and the civilian dump truck. In all instances, the load distribution factor obtained for the PLS truck was smaller than the value specified by the AASHTO Standard Specifications. Results concerning the dynamic load allowance factor for the PLS truck were inconclusive due to the difficulty in controlling the position of the truck over the bridge deck at high speeds. The information derived from this study will contribute in the development of accurate methodologies for the determination of load-carrying capacity of bridges.

15. SUBJECT TERMS

Bridge	Load Distribution Factors	T-Beam
Dynamic Load Allowance Factor	Reinforced Concrete	

16. SECURITY CLASSIFICATION OF:			17. LIMITATION OF ABSTRACT	18. NUMBER OF PAGES 57	19a. NAME OF RESPONSIBLE PERSON Yazmin Seda-Sanabria
a. REPORT UNCLASSIFIED	b. ABSTRACT UNCLASSIFIED	c. THIS PAGE UNCLASSIFIED			19b. TELEPHONE NUMBER (include area code) (601) 634-3761