

REPORT DOCUMENTATION PAGE

Form Approved
OMB No. 0704-0188

Public reporting burden for this collection of information is estimated to average 1 hour per response, including the time for reviewing instructions, searching data sources, gathering and maintaining the data needed, and completing and reviewing the collection of information. Send comments regarding this burden estimate or any other aspect of this collection of information, including suggestions for reducing this burden to Washington Headquarters Service, Directorate for Information Operations and Reports, 1215 Jefferson Davis Highway, Suite 1204, Arlington, VA 22202-4302, and to the Office of Management and Budget, Paperwork Reduction Project (0704-0188) Washington, DC 20503.

PLEASE DO NOT RETURN YOUR FORM TO THE ABOVE ADDRESS.

1. REPORT DATE (DD-MM-YYYY)		2. REPORT DATE Type Final, Technical		3. DATES COVERED (From - To) 1/1/1998 - 5/31/2003	
4. TITLE AND SUBTITLE Basic Research in Thermoacoustic Heat Transport				5a. CONTRACT NUMBER	
				5b. GRANT NUMBER N00014-98-1-0212	
				5c. PROGRAM ELEMENT NUMBER	
6. AUTHOR(S) Keolian, Robert M. Atchley, Anthony A.				5d. PROJECT NUMBER 03PR04687-00	
				5e. TASK NUMBER	
				5f. WORK UNIT NUMBER	
7. PERFORMING ORGANIZATION NAME(S) AND ADDRESS(ES) The Pennsylvania State University 110 Technology Center University Park, PA 16802				8. PERFORMING ORGANIZATION REPORT NUMBER NA	
9. SPONSORING/MONITORING AGENCY NAME(S) AND ADDRESS(ES) Office of Naval Research Ballston Centre Tower One 800 North Quincy Street Arlington, VA 22217-5660					
12. DISTRIBUTION AVAILABILITY STATEMENT Approved for Public Release; Distribution is Unlimited					
13. SUPPLEMENTARY NOTES Email Address: rmk10@psu.edu					
14. ABSTRACT Research in topics to improve the efficiency of thermoacoustic chillers and heat engines is summarized: (1) model a waste heat driven chiller for use on a Navy surface combatant; (2) develop a theory for thermoacoustic devices that do not use a stack; (3) perform experiments on a no-stack device; (4) experimentally map out the heat transfer and drag performance of various heat exchanger types in the presence of oscillating flow; (5) construct a compact thermoacoustic-Stirling engine for use in electrical power generation; (6) investigate Rayleigh streaming; (7) study the time-averaged pressure change across an abrupt change in resonator					
15. SUBJECT TERMS Refrigeration, Chiller, Thermal Management, Energy Conversion, Thermoacoustic, Stirling, Rayleigh Streaming, Heat Exchange, No-Stack cross section.					
16. SECURITY CLASSIFICATION OF:			17. LIMITATION OF ABSTRACT	18. NUMBER OF PAGES	19a. NAME OF RESPONSIBLE PERSON
a. REPORT	b. ABSTRACT	c. THIS PAGE			Anthony Atchley / Robert Keolian
U	U	U	UU	23	19b. TELEPHONE NUMBER (include area code) (814) 865-6364 (814) 865-1365

20031007 046

Final Technical Report
Office of Naval Research grant N00014-98-1-0212
Basic Research in Thermoacoustic Heat Transport
September 2003

Robert M. Keolian*[‡] and Anthony A. Atchley,* Principal Investigators
The Pennsylvania State University
***Graduate Program in Acoustics, and**
[‡]Applied Research Laboratory
P.O. Box 30, State College, PA 16804-0030

DISTRIBUTION STATEMENT A
Approved for Public Release
Distribution Unlimited

I. Introduction

This Final Report is a summary of the research performed under the grant N00014-98-1-0212, "Basic Research in Thermoacoustic Heat Transport," which was active from 1 January 1998 to 31 May 2003. The grant has been shared between the two principal investigators, Robert M. Keolian and Anthony A. Atchley. The work of the two groups is described below followed by a combined listing of external output in the form of papers, presentations and graduate students supported at least partially by the grant.

II. Keolian Group

A. Objective

The guiding objective of this portion of the grant has been to perform basic research that lowers the barriers to Naval or commercial adoption of thermoacoustic technology—namely studying issues that would improve the energy and volume efficiency of engines and refrigerators.

B. Approach

Our technical approach has been in several directions: 1) Model a thermoacoustic stack-based waste heat driven chiller for use on a Navy surface combatant. 2) Develop a theory for thermoacoustic refrigeration and sound generation in standing wave devices that do not use a stack. We call these "no-stack" devices. 3) Perform experiments on a no-stack device which models a radial heat driven chiller that we believe is compact enough to be useful to the Navy and commercially. 4) Experimentally map out the heat transfer and drag performance of various heat exchanger types in the presence of

oscillating flow. 5) Construct a compact thermoacoustic-Stirling (traveling wave style) engine for use in electrical power generation.

C. Synopsis of Scientific Accomplishments

1. Waste Heat Driven Chiller

Navy destroyers generate substantial amounts of waste heat in the form of the hot exhaust from their gas turbine engines which are used for main propulsion and electrical power generation. These high temperature exhaust streams make an attractive source of high quality waste heat to power a thermoacoustic refrigeration plant. Such a plant could provide chilled water for the ship, while at the same time cool the exhaust gases and substantially reduce the electrical load on the ship.

A thermoacoustic refrigerator uses high amplitude sound to pump heat from a cold to a warmer temperature. A thermoacoustic engine is used in the opposite direction, to generate sound from heat. What is described here is a heat driven thermoacoustic chiller that combines both types of devices. Figure 1 shows a cut-away sketch of a portion of a waste heat driven thermoacoustic chiller concept that we have modeled. The complete chiller is in the shape of an annulus that surrounds a hot exhaust duct, shown by the large arrow. Near the hot inner wall of the annulus, some of the hot exhaust is directed into the chiller and runs through a hot heat exchanger (labeled Hot HX), drawn in the sketch as a tube and fin type, although other types of exchangers are possible. The next item, working radially outward, is a stack, shown here as a stack of washer shaped rings. On the outer edge of this inner stack is another heat exchanger kept near the ambient temperature by an ambient temperature fluid, such as sea water, fresh water cooled by sea water, or outside ambient air. Similarly, towards the outside of the annulus are placed a cold heat exchanger, an outer stack, and an ambient heat exchanger. Ducting above and below the heat exchangers is provided for the ambient and cold heat exchange fluid streams. In the annular acoustic space surrounding the heat exchangers and stacks is the working gas, which can be, for example, a pressurized mixture of helium and xenon, for the best performance, or air at ambient pressure, for the most simplicity. Pure helium, or helium-argon mixtures can be used as well at various pressures, all giving various tradeoffs between performance and simplicity.

The inner stack, with its hot and ambient heat exchangers, is the source of sound. The large temperature gradient across this stack causes sound to spontaneously start oscillating in the radial direction. The sound shuttles heat out of the hot heat exchanger, moves it down the temperature gradient along the inner stack, and into the inner ambient exchanger, cooling the turbine exhaust gas and generating sound in the processes. These radial oscillations of the working gas then pump heat out of the cold heat exchanger on the outer side of the annulus, move it along the outer stack up a temperature gradient, and into the outer ambient heat exchanger, forming a refrigerator. The net result is that heat leaves both the hot exhaust and the chilled fluid and is deposited into the ambient fluid, all with no moving parts inside the annular resonator.

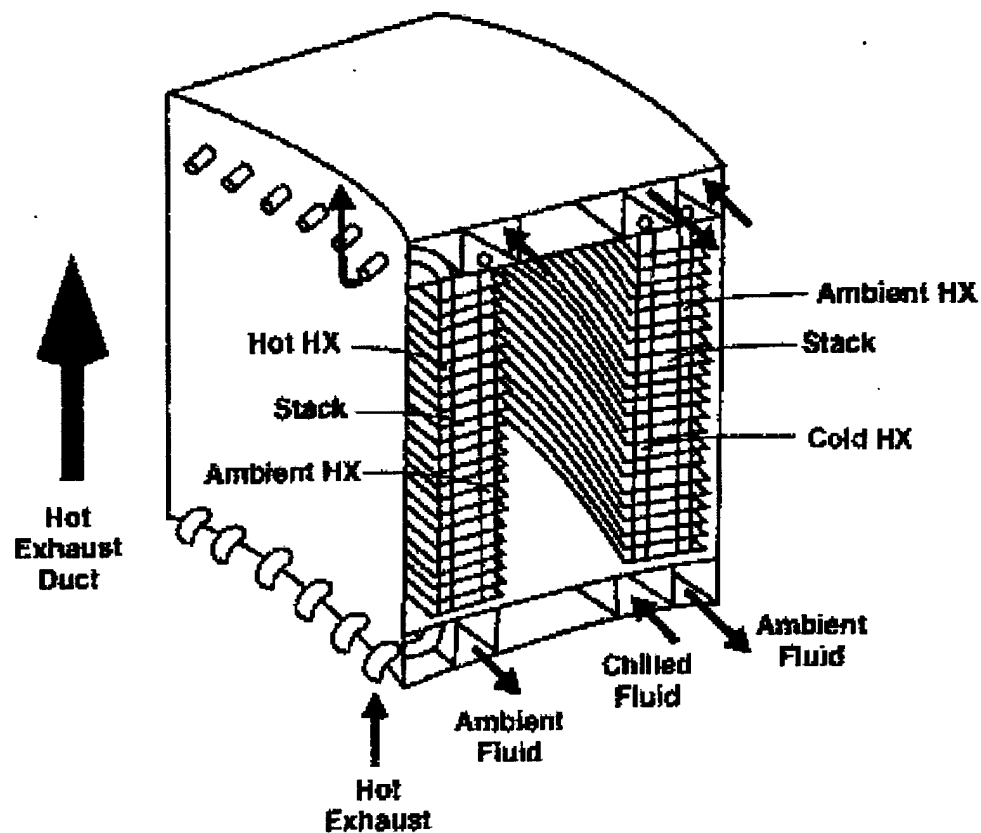

Figure 1. A stack-based waste heat driven chiller concept.

Note that the outer surface of the annular chiller is kept near ambient temperature by the outer ambient heat exchanger. One can think of the chiller as being like an “active lagging,” adding about 14 inches to the radius of the duct in one design, but replacing part of the lagging normally around a hot duct, thus saving space.

Performance of the chiller is dependent on the type of gas and pressure chosen for the working fluid. Computer models of the performance were made for an annular chiller surrounding a five foot diameter exhaust duct carrying combustion products at 980 °F, with an ambient water temperature of 95 °F and a chilled water temperature of 45 °F, for various gas and pressure combinations. The performance ranged from 8.8 tons of cooling (30.9 kW removed from the cold heat exchanger) per foot of active duct length for a helium-xenon working gas mixture at 3 atmospheres, to 3.7 tons of cooling per foot of active duct for air as the working gas at 1 atmosphere. These two cases pull 105 kW and 86 kW of energy out of the hot exhaust per foot of active duct, respectively. For long active ducts the performance will drop as the temperature of the exhaust gas is reduced.

Although the annular geometry of this chiller achieves good volumetric efficiency, the energy efficiency of stack-based standing-wave thermoacoustic devices

such as this is respectable, but not great—just over 20% of the ideal Carnot efficiency at best. It was thought that non-stellar energy efficiency would be acceptable in a waste heat driven system where the input energy is free. It should be noted that since this work was performed large energy efficiency improvements have been demonstrated for thermoacoustic-Stirling devices by our colleagues at Los Alamos, as described in item 5 below.

2. No-stack Theory

In a conventional standing wave thermoacoustic device, shown in Fig. 1 and again in Fig. 2(a), about half of the total dissipative energy loss occurs in the stack, mostly as a result of the irreversible heat transfer between the working gas and the stack with additional losses due to viscous “scrubbing” of the gas moving along the stack. The function of the stack is to put oscillating fluid elements, shown by the horizontal arrows, thermally in series, causing thermal energy to be transferred from element to element. This allows a thermoacoustic refrigerator or engine to span a large temperature difference between the hot and cold heat exchangers that straddle the stack while using a modest acoustic amplitude.

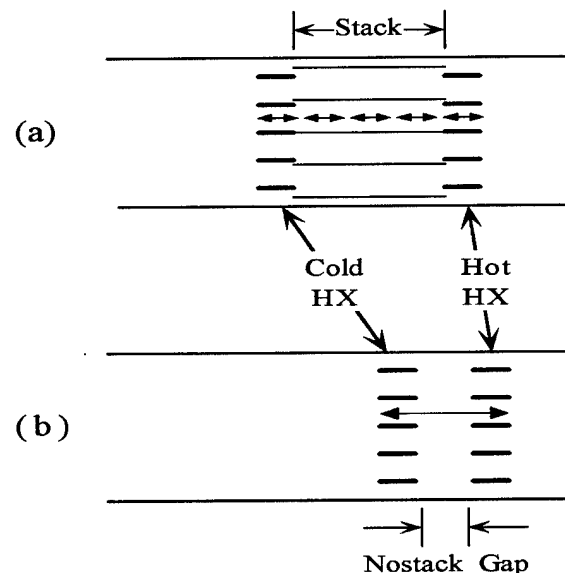

Figure 2. (a) A conventional standing wave thermoacoustic device with a stack sandwiched between hot and cold heat exchangers in a resonator. (b) A no-stack device where gas elements travel across the no-stack gap directly between the heat exchangers.

We have been studying an alternative system [Wakeland and Keolian (2002), “Thermoacoustics with Idealized Heat Exchangers and No Stack”] shown in Fig. 2(b), which is predicted to have higher efficiency and greater simplicity under the proper conditions. The stack has been removed and the acoustic amplitude is much increased to

the point that fluid elements are able to travel directly between the hot and cold heat exchangers. It is the “ram jet” of thermoacoustic devices.

To calculate the work and heat flows of the thermodynamic cycle, we follow the path of gas elements in a Lagrangian way between the two exchangers. Figure 3 shows the case of heat exchangers which are assumed to be perfect—a gas element immediately comes to the temperature of a metal fin, shown in gray, as soon as it comes into contact. Both the engine cycle (a) and refrigeration cycle (b) are shown. Losses are calculated in a Eulerian way, accounting for thermal, viscous and minor (nonlinear) losses at the heat exchangers, thermal-viscous losses at the resonator walls, and thermal conduction between the exchangers. In one refrigerator configuration, with the assumption of thermally *perfect* heat exchangers, the model predicted that the efficiency would be quite high, at 38% of the Carnot efficiency.

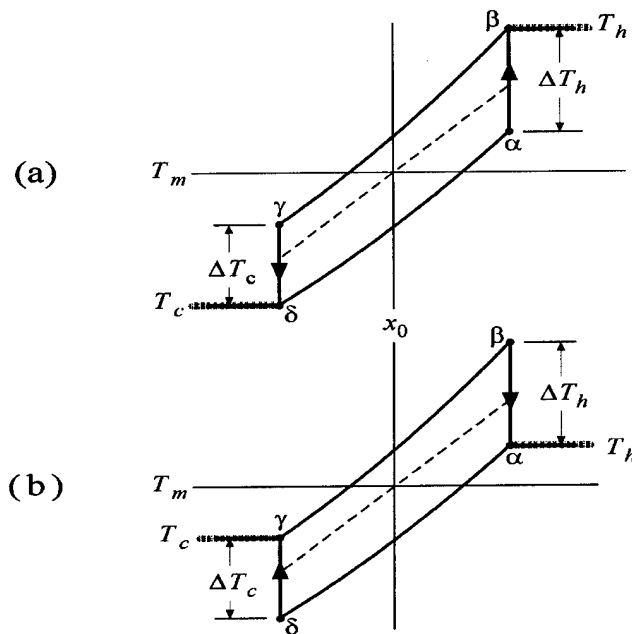

Figure 3. Temperature T vs. displacement x loops for no-stack gas elements going through (a) an engine cycle and (b) refrigeration cycle. Perfect heat exchange is assumed between the gas and heat exchangers, shown gray, at a hot temperature T_h and cold temperature T_c . Temperature is plotted vertically, Lagrangian position of the element is plotted horizontally.

Figure 3 instead shows the paths of gas elements for the case of *imperfect* heat exchange. The open area of the loop is roughly proportional to the amount of heat and work transferred by the element. The rate of heat transfer between the element and the heat exchanger fin is proportional to the parameter $C=1/(1000 \tau f)$, where τ is an effective thermal relaxation time between the gas and the heat exchanger and f is the frequency.

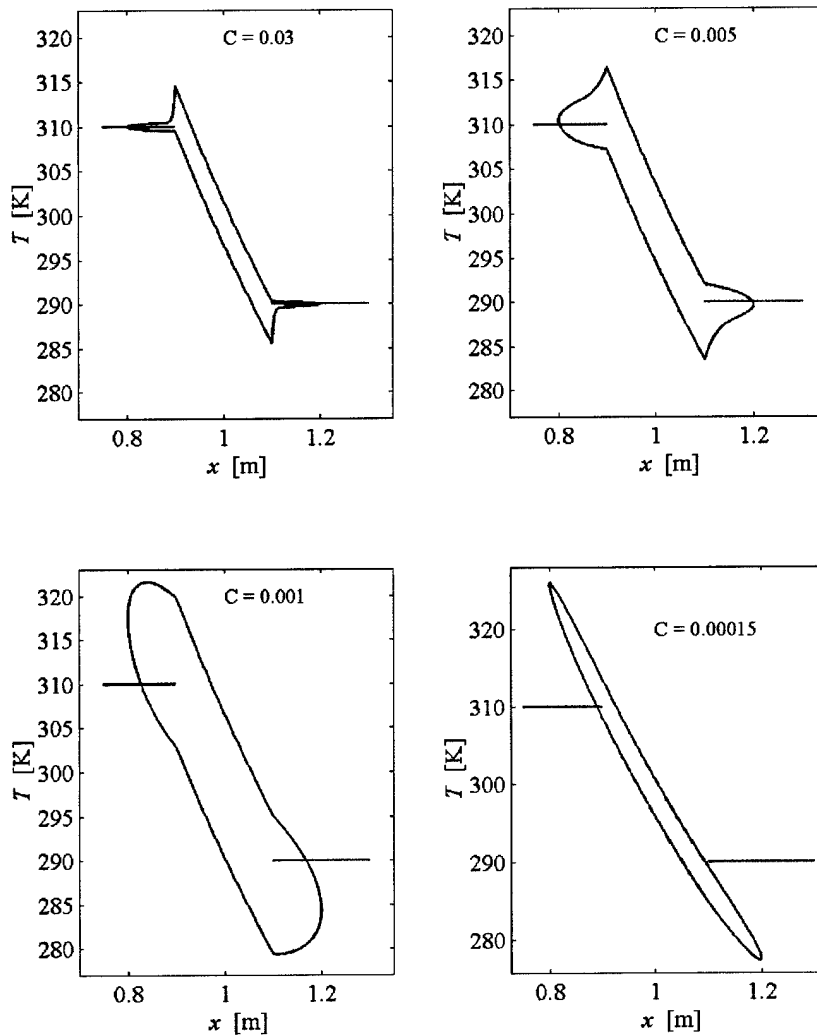

Figure 4. The temperature-position paths of a gas element in the case of imperfect heat exchange for a no-stack device. The rate of heat exchange between gas and fin is proportional to the parameter C .

We found [Wakeland and Keolian (2003) “Calculated effects of pressure-driven temperature oscillations on heat exchangers in thermoacoustic devices with and without a stack”] that pressure swings of the gas within a heat exchanger cause surprisingly large average heat flows even in heat exchangers that are nearly, but not quite, perfect. So much so that we had to revise the efficiency predictions of our no-stack paper from 38% down to 32% of the Carnot efficiency. Thus the no-stack approach, when optimized, can be expected to be more efficient than the stack-based approach, but not as good as the thermoacoustic-Stirling devices which have achieved efficiencies of 40% of Carnot.

3. No-stack experiments

We have tested some of our no-stack ideas in a resonator built to mimic a high power, radial, waste heat driven chiller similar to that in Fig. 1 but without a stack. We believe this geometry is compact enough for Navy ships or commercial use. We built a trapezoidal resonator to model a small section of an annular chiller. The resonator holds a no-stack engine at its narrow end. A refrigeration stage, if used, would go at the wider end. The heat for the engine comes from electrical heaters that substitute for the hot combustion products of a gas turbine.

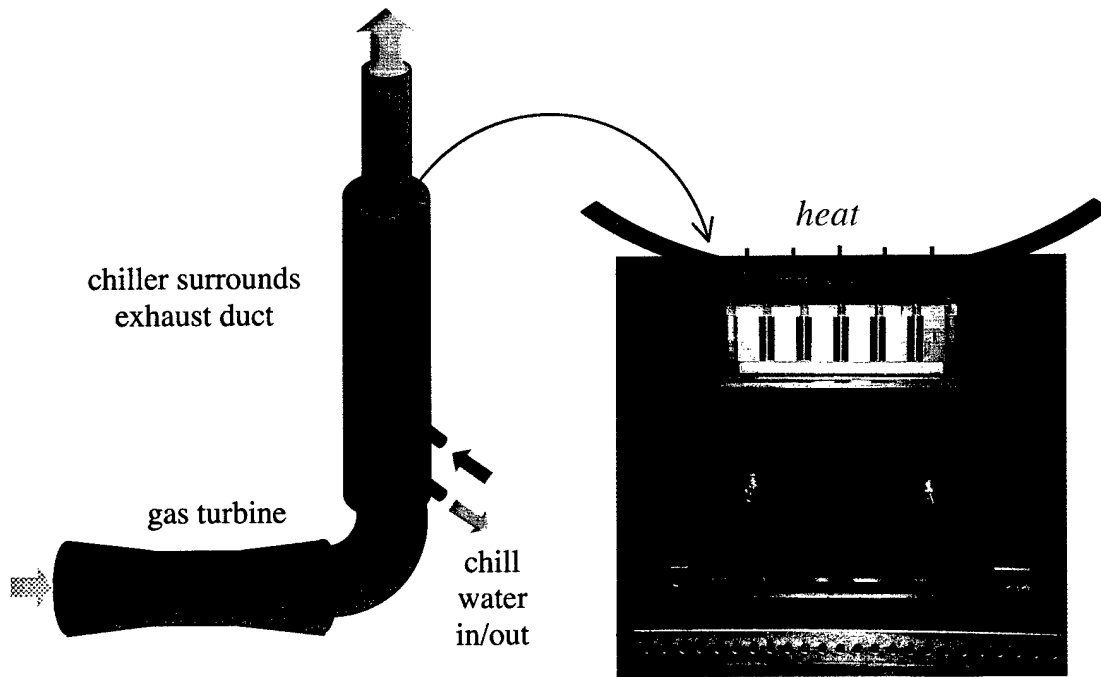

Figure 5. No-stack experiment. The experimental apparatus (on the right) is a trapezoidal resonator with heat input (red arrows) on the narrow end. A no-stack engine is near the top of the resonator. The trapezoidal geometry is motivated by being a small section of an annular waste heat driven chiller concept (on the left).

Much to our surprise, the engine achieved onset, but ran at an amplitude considerably smaller than that what was necessary for a gas parcel to travel the distance between the hot and cold heat exchangers. We have made a numerical model of these results that needed to include the heat transfer between gas parcels in the acoustic direction (an effect which is ignored in our no-stack paper). These experiments are not yet complete.

4. Oscillating Flow Heat Transfer Experiments

By placing two identical heat exchangers in an oscillating flow, separated by a gap, one can get a rather straightforward measurement of the oscillatory heat transfer coefficient under various conditions by measuring the heat flow between the exchangers and dividing by half of the temperature difference between them. The drag can be determined by the oscillatory pressure drop of the flow. These measurements are useful as input to our no-stack models, but should also be useful in the design of other thermoacoustic devices and as test cases for validation of computational acoustics calculations.

Our oscillating flow heat exchange and drag apparatus, shown in Fig. 6, relies on similitude. It's experimentally easier to build scaled up models of heat exchangers and run in the range of 0.1 to 10 Hz than at the 40 Hz to 10 kHz frequencies normally associated with thermoacoustic devices. Larger "acoustic" displacements and penetration depths allow for easier and more accurate construction of the heat exchanger models. Pressure and thermal instrumentation yield acoustic loss and heat transfer information.

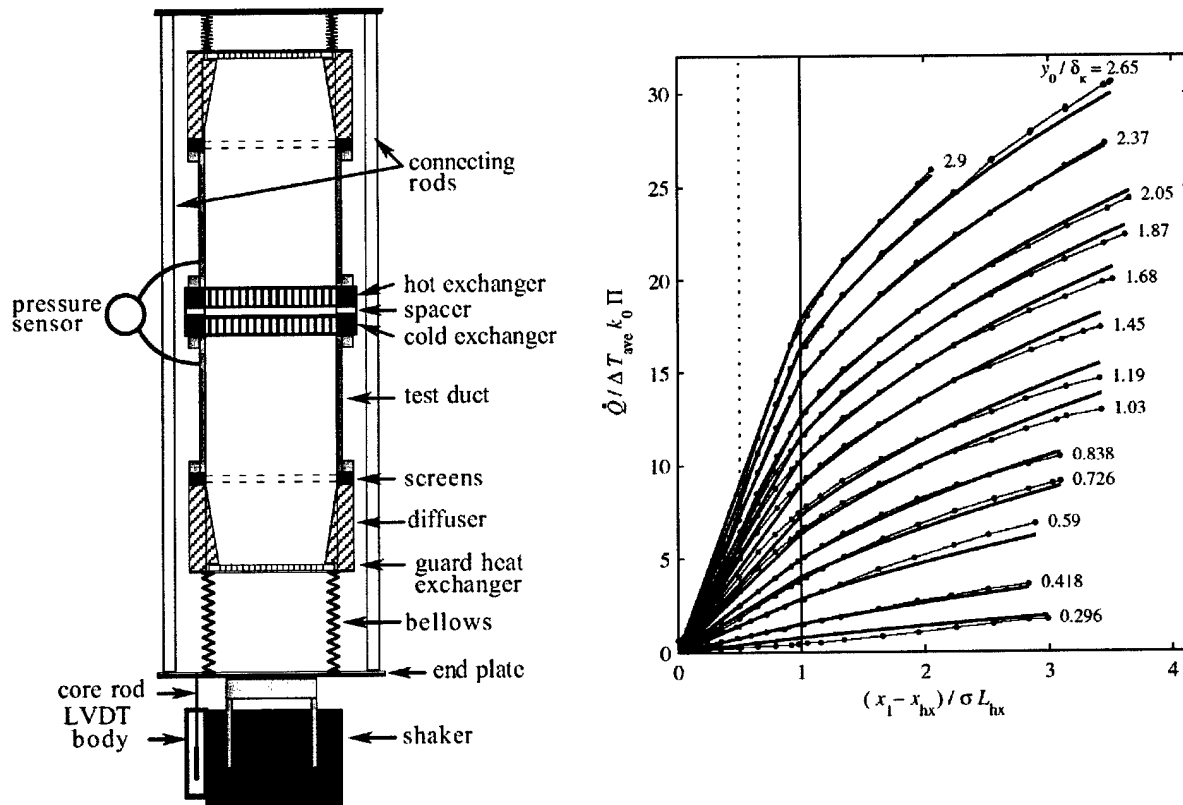

Figure 6. Oscillating flow heat exchange and drag apparatus, on left, and experimental heat transfer data (points) and correlations (heavy lines) fitting the data, on right.

The heat transfer measurements, some of which are also in Fig. 6, were distilled into an effectiveness model for heat exchange from oscillatory flow between parallel plate heat exchangers [Wakeland and Keolian (2003), "Effectiveness of parallel-plate heat exchangers in thermoacoustic devices"]. The drag measurements were reduced to fits for the acoustic resistance of parallel plate heat exchangers [Wakeland and Keolian (2003), "Measurements of the resistance of parallel-plate heat exchangers to oscillating flow at high amplitudes"] and individual screens [Wakeland and Keolian (2003), "Measurements of resistance of individual square-mesh screens to oscillating flow at low and intermediate Reynolds numbers"], as shown in Fig. 7. We believe this oscillating flow data and their fits will be generally useful to designers of thermoacoustic devices, even if the no-stack concept that motivated it fades from use.

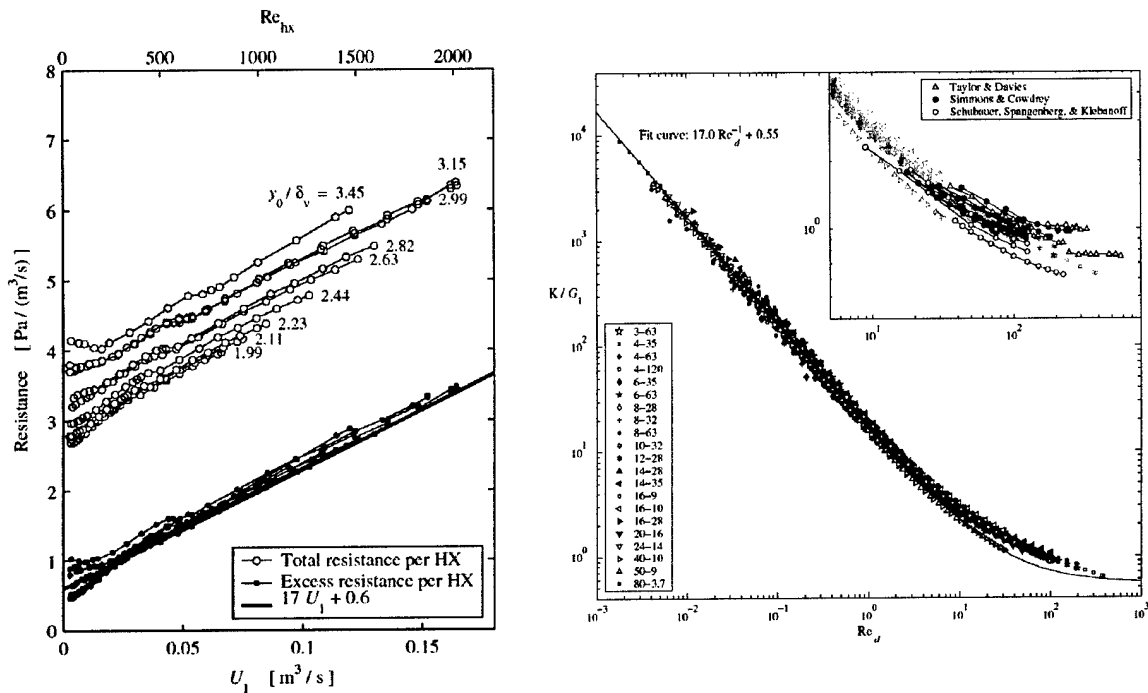

Figure 7. Oscillatory flow resistance measurements and fits for parallel plate heat exchangers, on left, and individual wire screens, on right.

5. Compact Thermoacoustic-Stirling Engine

Scott Backhaus and Greg Swift of the Los Alamos National Laboratory have vastly improved the possible efficiency of thermoacoustic devices with their invention of the thermoacoustic Stirling prime mover (Backhaus and Swift, *J. Acoust. Soc. Am.* **107**, 3148-3166 (2000)). However, their engine is quite large and has an unwieldy shape which seems unsuitable for placement on a Navy ship. We have constructed and are testing a more compact version of their engine that will be used in future work for the purpose of generating electrical power. We have given up some of the niceties of the flow present in the Backhaus and Swift apparatus in exchange for compactness, hoping

that the efficiency hit we expect to take will be more than made up by the inherent superiority of the Stirling cycle compared to the conventional stack-based thermoacoustic cycle. These experiments are ongoing.



Figure 8. Compact thermoacoustic-Stirling heat engine.

III. Atchley Group

A. Objective

The overall technical objective of this portion of the grant is to conduct a careful experimental investigation of high amplitude acoustic phenomena in geometrically-simple resonators. Applications of high amplitude acoustics, such as thermoacoustics, have stimulated the search for a fuller understanding of high-amplitude acoustics in closed systems than is accessible through analytical theory. As a result, several computational approaches have been investigated. While the ultimate goal of such modeling is application to practical configurations, the first steps are validation against experimental results acquired in geometrically-simple systems. The purpose of this portion of our research is to aid the development of these models by providing measurements of various nonlinear acoustic phenomena in computationally tractable resonator geometries against which to compare numerical predictions.

B. Approach

The technical approach has been to focus on two aspects of the problem: 1) Rayleigh streaming in cylindrical resonators, 2) the time-averaged pressure change across an abrupt change in resonator cross section.

C. Synopsis of Scientific Accomplishments

1. Rayleigh Streaming in Cylindrical Resonators

Classical theories of Rayleigh streaming in cylindrical tubes predicts the flow in the core outside the boundary layer to be a quadratic function of radial position. However, these theories are applicable to very low Reynolds numbers, consistent with axial components of the streaming velocity of a few mm/s or less. At higher Reynolds numbers, inertial effects, which are neglected in classical theories, become important. As pointed out by Menguy and Gilbert (*Acustica*, **86** 249-259, 2000), one consequence of including inertial effects is that the profiles are no longer parabolic. We have used laser Doppler anemometry to measure the time-averaged flow in a cylindrical resonator. Our measurements show a non-parabolic profile, as can be seen in Fig. 8. However, the deviation from parabolic is much greater than can be explained by including inertial effects. Measurements also show that the streaming velocity starts off near the classical-theory value and evolves over a time scale of several minutes. This evolution, which also has never been reported before, is correlated with the small acoustically generated temperature gradients induced along the resonator wall. These results imply that computational models need to account for long-term dynamics and thermoacoustic heat exchange with the wall. Details of these measurements are provided in the manuscript M. W. Thompson and A. A. Atchley, "Optical measurement of Rayleigh streaming in a standing wave with a temperature gradient," submitted to *J. Acoust. Soc. Am.*, June 2003.

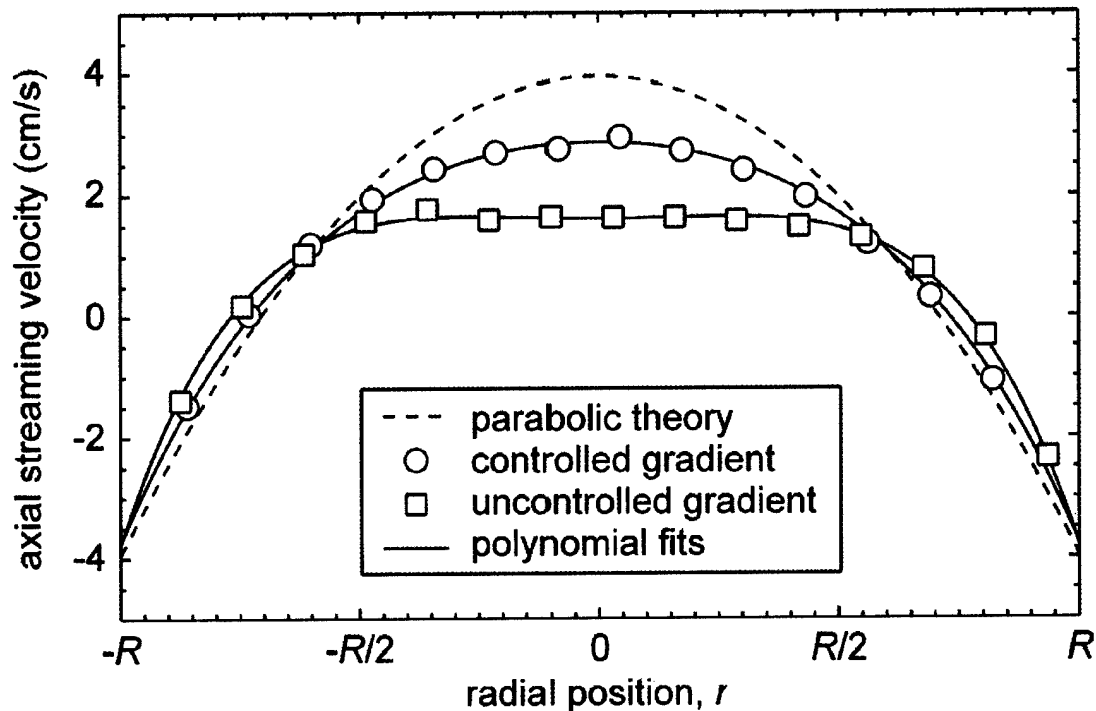

Figure 9. Axial streaming velocity across a cylindrical tube. "Controlled gradient" data has water circulating around the outside of the tube, keeping the tube at nearly constant temperature. "Uncontrolled gradient" data is taken without the circulating water.

2. Time Averaged Pressure Drops at Transitions

Abrupt changes in cross section occur in thermoacoustic engines at junctions between the resonator and heat exchangers, between heat exchangers and the stack, at jet pumps, and in the resonator itself. These changes in cross section can have both dissipative (resistive) and non-dissipative (reactive) effects, influencing both the nuisance loss in the resonator and its operating frequency. Unnecessary dissipation leads to a reduction in efficiency of an acoustic engine. Unaccounted-for reactance can lead to an engine operating at a non-optimal frequency, also reducing its efficiency. The influence of a change in cross section depends upon the geometrical properties of the change, its location in the sound field, and the amplitude of the sound field. As is the case with streaming, a thorough understanding of both the good and bad consequences of acoustic flows through changes in cross section is important for designing acoustics engines.

We have developed an experimental apparatus, shown in Fig. 9, that allows for temperature-controlled measurement of the acoustic power delivered to a resonator as well as the absolute, time-dependent pressure at several locations along the resonator wall. Measurements of the time-averaged pressure at the narrow end of a stepped-resonator are in very good agreement with computational results by Sparrow, et. al., (also ONR sponsored), based on a two dimensional unsteady compressible high-order Navier-

Stokes code specialized for aeroacoustics problems. The agreement demonstrates that the types of measurements pursued here are capable of serving their intended function, to validate computational models. This part of the project has been the subject of several presentations at meetings of the Acoustical Society of America. The details will be found in A. Doller's dissertation, scheduled to be completed at the end of December 2003, and subsequent publications.

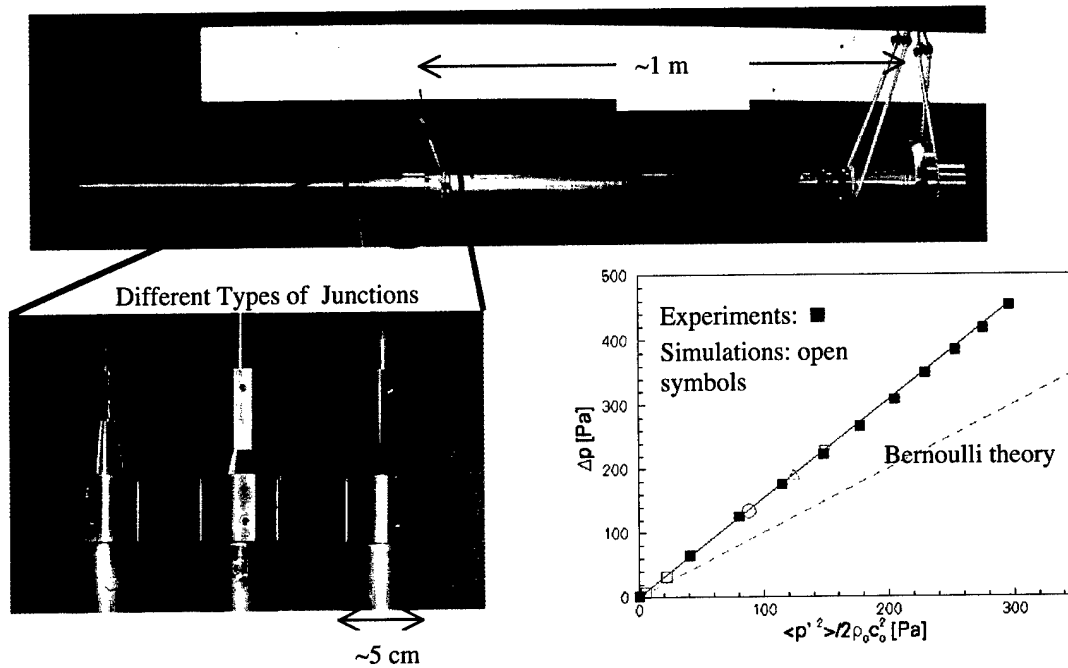

Figure 10. Apparatus for measurement of mean pressure differences, with comparison between experimental data, computational results, and Bernoulli theory.

IV. External Communications

A. Refereed Journal Publications:

1. J. Adef, T. J. Hofler, A. A. Atchley, and W. C. Moss, "Measurements with reticulated vitreous carbon stacks in thermoacoustic prime movers and refrigerators," *J. Acoust. Soc. Am.* **104**, 32-38 (1998).
2. R. S. Wakeland, "Use of electrodynamic drivers in thermoacoustic refrigerators," *J. Acoust. Soc. Am.* **107** (2), 827-832 (2000).
3. R. A. Johnson, S. L. Garrett, R. M. Keolian, "Thermoacoustic cooling for surface combatants," *Naval Engineer's Journal*, 335-345, July, 2000.
4. R. T. Muehleisen and A. A. Atchley, "Fundamental axial modes of a constricted annular resonator: theory and measurement," *J. Acoust. Soc. Am.* **109** (2), 480 - 487, 2001.
5. R. S. Wakeland and R. M. Keolian, "Thermoacoustics with Idealized Heat Exchangers and No Stack," *J. Acoust. Soc. Am.* **111** (6), 2654-2664 (2002).
6. R. S. Wakeland and R. M. Keolian, "Influence of velocity profile nonuniformity on minor losses for flow exiting thermoacoustic heat exchangers (L)," *J. Acoust. Soc. Am.*, **112** (4), 1249-1252 (2002).
7. T. B. Gabrielson, M. E. Poese, and A. A. Atchley, "Acoustic and vibration background noise in the collapsed structure of the World Trade Center (L)," *J. Acoust. Soc. Am.* **113**(1), 45-48, 2003.
8. K. J. Bastyr, R. M. Keolian, "High-frequency acoustic-Stirling heat engine demonstration device," *ARLO*, **4**, 37-40 (2003).
9. R. S. Wakeland and R. M. Keolian, "Measurements of resistance of individual square-mesh screens to oscillating flow at low and intermediate Reynolds numbers," to be published, *J. Fluids Eng.*, 2003.
10. M. W. Thompson and A. A. Atchley, "Optical measurement of Rayleigh streaming in a standing wave with a temperature gradient," submitted to *J. Acoust. Soc. Am.*, June 2003.
11. R. S. Wakeland and R. M. Keolian, "Effectiveness of parallel-plate heat exchangers in thermoacoustic devices," submitted to *J. Acoust. Soc. Am.*, July 2003.
12. R. S. Wakeland and R. M. Keolian, "Measurements of the resistance of parallel-

plate heat exchangers to oscillating flow at high amplitudes,” submitted to *J. Acoust. Soc. Am.*, July 2003.

13. R. S. Wakeland and R. M. Keolian, “Calculated effects of pressure-driven temperature oscillations on heat exchangers in thermoacoustic devices with and without a stack,” submitted to *J. Acoust. Soc. Am.*, July 2003.

B. Conference Proceedings

1. R. T. Muehleisen, A. A. Atchley, D. D. Herbert, and A. R. Salindong, “Measurements and empirical model of temperature evolution in a short stack,” *Heat Transfer – Baltimore 1997*, AIChE Symposium Series No. 314, Vol. 93 (1997).
2. T.G. Simmons, B. Denardo, A. Larraza, R. Keolian, “Acoustic Radiometer Demonstration,” *Proceedings of ICA/ASA '98*, 16th Intl. Congress on Acoust. and 135th Meeting of Acoust. Soc. Am., pp.129-130 (1998).
3. M. V. Golden, R. M. Keolian, S. L. Garrett, “Sonic Gas Analysis,” *Proceedings of ICA/ASA '98*, 16th Intl. Congress on Acoust. and 135th Meeting of Acoust. Soc. Am., pp. 1705-6 (1998).
4. R. Stern, R. Keolian, S. Garrett, “Isadore Rudnick Memorial Session,” *Proceedings of ICA/ASA '98*, 16th Intl. Congress on Acoust. and 135th Meeting of Acoust. Soc. Am., pp. 1731-2 (1998).
5. R. M. Keolian, “Izzy Rudnick's Educational Demonstrations and Videos,” *Proceedings of ICA/ASA '98*, 16th Intl. Congress on Acoust. and 135th Meeting of Acoust. Soc. Am., pp. 1735-6 (1998).
6. A. A. Atchley, “Sonoluminescence,” *Proceedings of the 1998 Physical Acoustics Summer School*, Vol. 1, p 7 - 37, University of Mississippi Technical Publication (1999).
7. R. W. M. Smith, S. L. Garrett, R. M. Keolian, J. A. Corey, “High Efficiency 2-kW Thermoacoustic Driver,” *Proceedings of the Joint Meeting of the ASA/EAA/DAGA*, Berlin, Germany, 15-19 March 1999.
8. A. A. Atchley, B. Carter, R. T. Muehleisen, H. T Lin, “Annular Thermoacoustic Engines,” in *Nonlinear Acoustics at the Turn of the Millennium: ISNA 15*, edited by W. Lauterborn and T. Kurz (American Institute of Physics, New York, 2000), 227-230.
9. A. A. Atchley, “An Introduction to Thermoacoustics: Underlying Principles and

Research Challenges,” Proceedings of the 17th International Congress in Acoustics, Rome Italy, September 2001.

10. A. A. Atchley, “Introduction to Physical Acoustics,” Proceedings of the 2000 Physical Acoustics Summer School, Vol. 1, p 7 - 37, University of Mississippi Technical Publication (2001).
11. R. M. Keolian, “Thermoacoustic Devices,” Proceedings of the 2000 Physical Acoustics Summer School, Vol. 1, University of Mississippi Technical Publication (2001).
12. M. W. Thompson and A. A. Atchley, “Measurement of Rayleigh Streaming in High-Amplitude Standing Waves,” to appear in the Proceedings of the 17th International Symposium on Nonlinear Acoustics, 2003.

C. Miscellaneous Publications and Patents

1. A. A. Atchley, “Sound waves rev up heat engines,” *Physics World*, p. 21, August 1999.
2. S. L. Garrett, R. M. Keolian, R. W. M. Smith, “High-Efficiency Moving Magnet Loudspeaker,” US Patent No. 6,307,287 (Oct. 2001).
3. R. M. Keolian, R. S. Wakeland, S. J. Turneure, “Thermoacoustic Device Without Stack or Regenerator,” Provisional patent application filed June 2001, and May 2002 (Docket 2001-0718).
4. R. M. Keolian and K. J. Bastyr, “Thermoacoustic Piezoelectric Generator,” Penn State University Invention Disclosure No. 2003-0719 (March 2003).

D. Conference Presentations with Published Abstracts

(* indicates invited presentation)

1. T.G. Simmons, B. Denardo, A. Larraza, R. Keolian, “An acoustic radiometer,” 135th Meeting of the Acoustical Society of America, Seattle, WA, June 1998, *J. Acoust. Soc. Am.* **103** (5), Pt. 2, 2763 (1998).
2. R. T. Muehleisen, and A. A. Atchley, “Simple model for the temperature gradient formation in a short stack,” 135th Meeting of the Acoustical Society of America, Seattle, WA, June 1998, *J. Acoust. Soc. Am.* **103** (5), Pt. 2, 2840(A) (1998).
3. M. V. Golden, R. M. Keolian, S. L. Garrett, “Sonic gas analyzers,” 135th Meeting

of the Acoustical Society of America, Seattle, WA, June 1998, *J. Acoust. Soc. Am.* **103** (5), Pt. 2, 2944 (1998).

4. *R. Stern, R. Keolian, S. Garrett, "Memorial session for Isadore Rudnick," 135th Meeting of the Acoustical Society of America, Seattle, WA, June 1998, *J. Acoust. Soc. Am.* **103** (5), Pt. 2, 2947 (1998).
5. *R. M. Keolian, "Izzy Rudnick's educational demonstrations and videos," 135th Meeting of the Acoustical Society of America, Seattle, WA, June 1998, *J. Acoust. Soc. Am.* **103** (5), Pt. 2, 2948 (1998).
6. R. T. Muehleisen, and A. A. Atchley, "Lumped impedance of a planar discontinuity in an acoustic waveguide," 135th Meeting of the Acoustical Society of America, Seattle, WA, June 1998, *J. Acoust. Soc. Am.* **103** (5), Pt. 2, 3074 (A) (1998).
7. *R. M. Keolian, "Acoustical phase locking," 136th Meeting of the Acoustical Society of America, Norfolk, VA, October 1998, *J. Acoust. Soc. Am.* **104** (3), Pt. 2, 2948 (1998).
8. B. A. Carter and A. A. Atchley, "Performance of a two-stack annular prime mover," 137th Meeting of the Acoustical Society of America, 2nd Convention of the European Acoustics Association: Forum Acusticum 99 integrating the 25th German Acoustics DAGA Conference, Berlin, Germany, March 1999, *J. Acoust. Soc. Am.* **105** (2), Pt. 2, 1072 (A) (1999).
9. R. W. M. Smith, R. M. Keolian, S. Garrett, "High-Efficiency 2-kW thermoacoustic driver," 137th Meeting of the Acoustical Society of America, 2nd Convention of the European Acoustics Association: Forum Acusticum 99 integrating the 25th German Acoustics DAGA Conference, Berlin, Germany, March 1999, *J. Acoust. Soc. Am.* **105** (2), Pt. 2, 1072 (1999).
10. R. M. Keolian, "Hydrodynamic analog of a thermoacoustic device," 137th Meeting of the Acoustical Society of America, 2nd Convention of the European Acoustics Association: Forum Acusticum 99 integrating the 25th German Acoustics DAGA Conference, Berlin, Germany, March 1999, *J. Acoust. Soc. Am.* **105** (2), Pt. 2, 1214 (1999).
11. A. A. Atchley, B. Carter, R. T. Muehleisen, H. T. Lin, "Annular thermoacoustic engines," 15th International Symposium on Nonlinear Acoustics, Goettingen, Germany, 1 - 4 September, 1999.
12. R. M. Keolian, "Hot topics in physical acoustics," 138th Meeting of the Acoustical Society of America, Columbus, OH, November 1999, *J. Acoust. Soc. Am.* **106**, Pt. 2, 2224 (1999).
13. R. S. Wakeland, "Use of electrodynamic drivers in thermoacoustic refrigerators,"

138th Meeting of the Acoustical Society of America, Columbus, OH, November 1999, *J. Acoust. Soc. Am.* **106** (4), Pt. 2, 2264 (1999).

14. R. S. Wakeland, "Characterization of the nuisance heat load in a thermoacoustic refrigeration demonstration device," 138th Meeting of the Acoustical Society of America, Columbus, OH, November 1999, *J. Acoust. Soc. Am.* **106** (4), Pt. 2, 2265 (1999).
15. *R. S. Wakeland, "Music to a physicist's ears," Annual Meeting of the American Association for the Advancement of Science, 2000.
16. R. S. Wakeland and R. M. Keolian, "Traveling-wave heat pumping in stack-spaced pores," 139th Meeting of the Acoustical Society of America, Atlanta, GA, May 2000, *J. Acoust. Soc. Am.* **107** (5), Pt. 2, 2795 (2000).
17. R. S. Wakeland and R. M. Keolian, "Nostack thermoacoustics," 140th Meeting of the Acoustical Society of America, Newport Beach, CA, December 2000, *J. Acoust. Soc. Am.* **108** (5), Pt. 2, 2569 (2000).
18. A. Doller, A. A. Atchley, and R. Waxler, "Time-averaged pressure drop produced by an abrupt change in a resonator's cross section," 140th Meeting of the Acoustical Society of America, Newport Beach, CA, December 2000, *J. Acoust. Soc. Am.* **108** (5), Pt. 2, 2569 (A) (2000).
19. D. Najolia, A. A. Atchley, C. B. Burroughs and J. Fahnlne, "Modal response of coupled spaces," 140th Meeting of the Acoustical Society of America, Newport Beach, CA, December 2000, *J. Acoust. Soc. Am.* **108** (5), Pt. 2, 2648 (A) (2000).
20. R. S. Wakeland and R. M. Keolian, "Numerical model of heat exchangers in oscillating flow with oscillating pressure," 141st Meeting of the Acoustical Society of America, Chicago, IL, June 2001, *J. Acoust. Soc. Am.* **109**, Pt. 2, 2405 (2001).
21. A. A. Atchley, R. Waxler, A. Doller, and M. Thompson, "Time-averaged effects of a constriction in an acoustic resonator," *First International Workshop on Thermoacoustics*, 's-Hertogenbosch, The Netherlands (2001). (Poster Presentation.)
22. *A. A. Atchley, "An Introduction to thermoacoustics: Underlying Principles and Research Challenges," Keynote Lecture, International Congress in Acoustics, Rome Italy, September 2001.
23. S. J. Turneure, R. S. Wakeland and R. M. Keolian, "Performance of a thermoacoustic prime mover without a stack," 142nd Meeting of the Acoustical Society of America, Fort Lauderdale, FL, December 2001, *J. Acoust. Soc. Am.* **110** (5), Pt. 2, 2677 (2001).
24. R. M. Keolian, "Hot topics in physical acoustics," 142nd Meeting of the Acoustical

Society of America, Fort Lauderdale, FL, December 2001, *J. Acoust. Soc. Am.* **110** (5), Pt. 2, 2715 (2001); Presentation made by A. A. Atchley.

25. M. W. Thompson and A. A. Atchley, "Measurement of Rayleigh streaming in high-amplitude standing waves using laser Doppler anemometry," 143rd Meeting of the Acoustical Society of America, Pittsburgh, PA, June 2002, *J. Acoust. Soc. Am.* **111** (5), Pt. 2, 2418 (A) (2002).
26. R. S. Wakeland and R. M. Keolian, "Minor-loss coefficients for the exit from heat exchangers in thermoacoustics," 143rd Meeting of the Acoustical Society of America, Pittsburgh, PA, June 2002, *J. Acoust. Soc. Am.* **111** (5), Pt. 2, 2419 (2002).
27. *M. W. Thompson and A. A. Atchley, "Measurement of Rayleigh streaming in high-amplitude standing waves," 17th International Symposium on Nonlinear Acoustics, Moscow Russia, August, 19-23 2002.
28. M. W. Thompson and A. A. Atchley, "Measurement of the time evolution of Rayleigh streaming in high-amplitude standing waves," First Pan-American/Iberian Meeting on Acoustics, combining the 144th Meeting of the Acoustical Society of America, 3rd Iberoamerican Congress of Acoustics, 9th Mexican Congress on Acoustics, Cancun, Mexico, December 2002, *J. Acoust. Soc. Am.* **112** (5), Pt. 2, 2298 (A) (2002).
29. A. J. Doller, S. Boluriaan, A. A. Atchley, and P. J. Morris, "Computational and experimental investigation of minor losses in high amplitude acoustic resonators with varied cross section," First Pan-American/Iberian Meeting on Acoustics, combining the 144th Meeting of the Acoustical Society of America, 3rd Iberoamerican Congress of Acoustics, 9th Mexican Congress on Acoustics, Cancun, Mexico, December 2002, *J. Acoust. Soc. Am.* **112** (5), Pt. 2, 2298 (A) (2002).
30. *R. M. Keolian, "Phase locking," 145th Meeting of the Acoustical Society of America, Nashville, TN, April 2003, *J. Acoust. Soc. Am.* **113**, Pt. 2, 2240 (2003).

E. Students Supported

¹ This grant supported research expenses only.

² Stipend and tuition provided by the Penn State Applied Research Laboratory Exploratory and Foundational Program.

Ph.D. Students

1. Ray S. Wakeland, "Heat Exchangers in Oscillating Flow, with Application to Thermoacoustic Devices That Have Neither Stack Nor Regenerator," Doctor of Philosophy in Acoustics, August 2003.
2. Andrew Doller, "Time-Averaged Pressure Drop Across an Abrupt Change in Resonator Cross Section," Doctor of Philosophy in Acoustics (Anticipated graduation date December, 2003).¹
3. Michael W. Thompson, "Optical Measurements of Rayleigh Streaming in High Amplitude Standing Waves," Doctor of Philosophy in Acoustics (Anticipated graduation date May, 2004).^{1,2}
4. Kevin J. Bastyr, Doctor of Philosophy in Acoustics (Anticipated graduation date May, 2004).^{1,2}

Masters Student

1. B. Carter, "Investigation of a Dual-Stack Annular Thermoacoustic Prime Mover," Master of Science in Acoustics, 1999.^{1,2}

Undergraduate Honors Student

1. Charles A. Monroe, "Minimizing Entropy Production due to Conduction in a Heat Exchanger for a Thermoacoustic Refrigerator," Undergraduate Honors Thesis, Department of Mechanical Engineering, May 2003.¹

Postdoctoral Scholars

1. John W. Parkins
2. Stefan J. Turneaure

GREGORY W SWIFT
LOS ALAMOS NATL LAB
K764
LOS ALAMOS NM 87545

OREST G SYMKO
DEPT OF PHYSICS
UNIV OF UTAH
115 S 1400 E
RM 201 JFB
SALT LAKE CITY UT 84112-0830

LARRY A WILEN
DEPT PHYSICS AND ASTRONOMY
OHIO UNIV
CLIPPINGER LABS
ATHENS OH 45701-0882