

ERDC/ITL TR-03-5

Information Technology Laboratory



**US Army Corps  
of Engineers®**  
Engineer Research and  
Development Center

*Innovations for Navigation Projects Research Program*

## **Design by Analysis of Innovative Navigation Structures**

**User Manual**

Kerry T. Slattery and Guillermo A. Riveros

August 2003

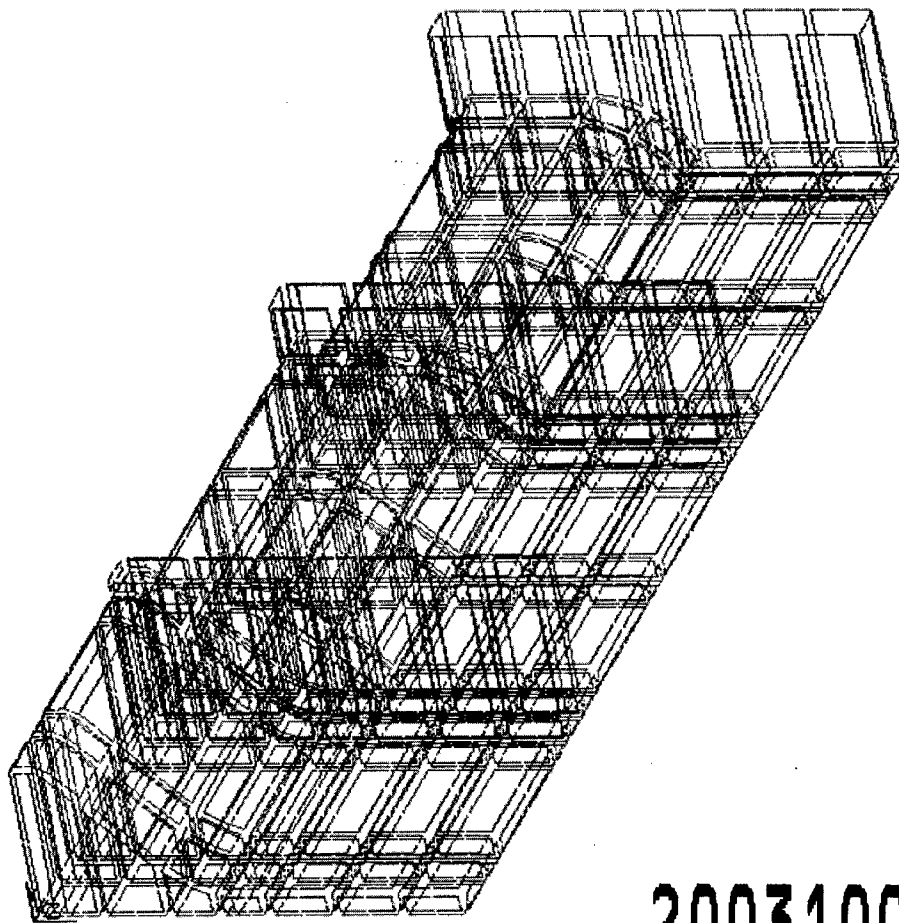

20031007 029

# **Design by Analysis of Innovative Navigation Structures**

## **User Manual**

Kerry T. Slattery

*Southern Illinois University  
Carbondale, IL 62901*

Guillermo A. Riveros

*Information Technology Laboratory  
U.S. Army Engineer Research and Development Center  
3909 Halls Ferry Road  
Vicksburg, MS 39180-6199*

Final report

Approved for public release; distribution is unlimited

Prepared for    **U.S. Army Corps of Engineers**  
                    **Washington, DC 20314-1000**  
Under            **Work Unit 33273**

**ABSTRACT:**

This report is the user manual for the "Design by Analysis System-Innovative Navigation Structures" (DBAS-INS). The Windows-based computer program creates a solid, three-dimensional (3D) finite element model of innovative structures fabricated using "in-the-wet" construction methods, such as the Braddock Dam currently under construction in the U.S. Army Corps of Engineers' Pittsburgh District. These structures are initially fabricated as a floating shell in a dry dock. The floating shell is divided into a 2D grid of hollow cells separated by reinforced concrete walls. Most significant structural loads involve hydrostatic pressures on the walls as the segment is floated to the installation site, lowered to the foundation, and filled with tremie concrete. The individual concrete slabs that form the walls of the cells must be designed for shear, moment, and thrust loads caused by the expected load combinations on the structure.

DBAS-INS procedures were developed to assist in the design and analysis of innovative navigation structures by simplifying the steps required to describe a new design, create a finite element model, check all load cases, design the reinforced concrete structure, and study modifications to the design. The DBAS-INS program allows the designer to create an accurate finite element model for a complex, 3D structure and to complete a preliminary layout and design in a fraction of the time normally required. After analysis, the program checks design requirements per ACI 318-02 (American Concrete Institute "Building Code Requirements for Structural Concrete") and, based on these results, can automatically modify the design and reanalyze the model.

**DISCLAIMER:** The contents of this report are not to be used for advertising, publication, or promotional purposes. Citation of trade names does not constitute an official endorsement or approval of the use of such commercial products. All product names and trademarks cited are the property of their respective owners. The findings of this report are not to be construed as an official Department of the Army position unless so designated by other authorized documents.

# Contents

---

Conversion Factors, Non-SI to SI Units of Measurement.....	viii
Preface.....	ix
1—Introduction.....	1
1.1 Background.....	1
1.2 Installation of DBAS-INS.....	5
1.3 Program Organization.....	5
2—File.....	6
2.1 New.....	6
2.2 Open.....	6
2.3 Save.....	6
2.4 Save As.....	6
2.5 Exit.....	6
3—Configure.....	8
3.1 Shell Refinement.....	8
3.2 Backup Interval.....	9
3.3 Set Tolerance.....	9
3.4 Dimension Display.....	10
4—View.....	11
4.1 Update View.....	11
4.2 Zoom In.....	11
4.3 Zoom Out.....	12
4.4 Fit View.....	12
4.5 Box Zoom.....	12
4.6 Three-Dimensional Views.....	12
4.7 Render.....	12
4.8 Plot Control.....	16
5—Preprocess.....	19
5.1 Numbered Sections.....	19
5.2 Lettered Sections.....	22
5.3 Outline Section.....	23
5.3.1 Spillway templates.....	23
5.3.2 Dimension sets.....	24
5.3.3 Section number.....	28

5.3.4 Phase.....	28
5.4 Update Top View.....	28
5.5 Generate Elements .....	31
6—Analyze.....	32
6.1 Materials .....	32
6.2 Boundary Conditions .....	34
6.3 Zone Pressures .....	36
6.4 Analyze Model.....	37
7—Postprocess .....	38
7.1 Deformed Shape .....	38
7.2 Shear, Moment, and Thrust Contours .....	38
7.3 Stress Contours .....	42
7.3.1 Surface stresses.....	42
7.3.2 Cross-section stresses .....	43
7.4 Shear, Moment, and Thrust Diagrams .....	46
7.5 Design Concrete.....	48
8—Modify .....	50
9—Report .....	51
9.1 Design Summary.....	51
9.2 Neutral Geometry File .....	51
Appendix A: Example Problem 1—Floor Slab.....	A1
Appendix B: Example Problem 2—Complete Section .....	B1
Appendix C: Neutral Geometry File Format.....	C1
SF 298	

## List of Figures

---

Figure 1.1	Main DBAS-INS form .....	2
Figure 1.2	Plan view of a dam segment.....	3
Figure 1.3	Perspective view of model with 3D coordinate system.....	4
Figure 2.1	File menu option.....	6
Figure 2.2	Save As form.....	7
Figure 3.1	Configure menu option.....	8
Figure 3.2	Shell refinement .....	9
Figure 3.3	Backup interval .....	9
Figure 3.4	Set tolerance .....	10

Figure 3.5	Dimension display option.....	10
Figure 4.1	View option.....	11
Figure 4.2	Box Zoom selection .....	13
Figure 4.3	Box Zoom results .....	14
Figure 4.4	Three-dimensional view options .....	15
Figure 4.5	View rotation form.....	15
Figure 4.6	Render options.....	15
Figure 4.7	Rendering of stresses.....	16
Figure 4.8	Plot control form .....	17
Figure 4.9	Results with selected plot options .....	18
Figure 5.1	Preprocess option .....	19
Figure 5.2	Number of Numbered Section lines .....	20
Figure 5.3	Width of the segment .....	20
Figure 5.4	Numbered Section Coordinates form.....	20
Figure 5.5	Shell elements for simple rectangular model .....	21
Figure 5.6	Modified shell RefN values.....	21
Figure 5.7	Form to enter location of lettered sections .....	22
Figure 5.8	Outline design controls.....	23
Figure 5.9	Fixed-crest weir template parameter definition.....	23
Figure 5.10	Water quality gate bay template parameter definition .....	24
Figure 5.11	Standard gate bay template parameter definition .....	24
Figure 5.12	Rectangular template parameter definition .....	24
Figure 5.13	Fixed-crest weir outside shape parameters.....	25
Figure 5.14	Water quality gate bay outside shape parameters.....	25
Figure 5.15	Standard gate bay outside shape parameters .....	25
Figure 5.16	Rectangle outside shape parameters.....	26
Figure 5.17	Fixed-crest weir thickness parameters.....	26
Figure 5.18	Taper dimension definition .....	27
Figure 5.19	Taper Types form.....	27
Figure 5.20	Fixed-crest weir taper parameters .....	28

Figure 5.21	Top view shows section line/diaphragm locations.....	29
Figure 5.22	Material assignments.....	30
Figure 5.23	Text boxes reduced to “buttons” in Top View.....	31
Figure 5.24	Design information.....	31
Figure 6.1	Analyze option.....	32
Figure 6.2	Materials form options.....	33
Figure 6.3	Material definition.....	33
Figure 6.4	Add a new material.....	34
Figure 6.5	Boundary Conditions form.....	34
Figure 6.6	Set Down Shaft locations.....	35
Figure 6.7	Drilled Pier Stiffness form.....	36
Figure 6.8	Input Fluid Depths in cells.....	37
Figure 6.9	Nodal Force form.....	37
Figure 7.1	Postprocess option.....	38
Figure 7.2	Deformation multiplier.....	38
Figure 7.3	Deformed shape plot.....	39
Figure 7.4	View   Render option.....	39
Figure 7.5	Set the Extents of the model to be plotted in the Plot Control form.....	40
Figure 7.6	Moment contours.....	40
Figure 7.7	Shear, moment, and thrust naming convention.....	41
Figure 7.8	Thrust results.....	41
Figure 7.9	Stress contours on superelements.....	42
Figure 7.10	Plot of Z-direction stresses.....	43
Figure 7.11	The minimum Extent designates which cross section to plot.....	44
Figure 7.12	The X-stresses through the midplane of a model.....	44
Figure 7.13	Plot Control indicating location of the plot in red.....	45
Figure 7.14	Change to a plot of Y stresses on an XY plane.....	45
Figure 7.15	Shear Moment Thrust form.....	46
Figure 7.16	Select a box for SMT plotting.....	47

Figure 7.17	Shear, moment, and thrust on a bottom slab .....	48
Figure 7.18	Top View to display design information.....	49
Figure 7.19	Design information.....	49
Figure 8.1	Modify option.....	50
Figure 9.1	Report option.....	51

# Conversion Factors, Non-SI to SI Units of Measurement

---

Non-SI units of measurement used in this report can be converted to SI units as follows:

Multiply	By	To Obtain
foot-pounds (force)	1.355818	joules
feet	0.3048	meters
inches	25.4	millimeters
kips (force) per square foot	47.88026	kilopascals
pounds (force)	4.448222	newtons
pounds (mass)	0.4535924	kilograms
pounds (mass) per cubic foot	16.01846	kilograms per cubic meter

# Preface

---

The work described in this report was authorized by Headquarters, U.S. Army Corps of Engineers (HQUSACE), as part of the Innovations for Navigation Projects (INP) Research Program. The study was conducted under Work Unit (WU) 33273, "Integrated Design and Analysis System for Navigation Structures," managed at the U.S. Army Engineer Research and Development Center (ERDC), Vicksburg, MS.

Dr. Tony C. Liu was the INP Coordinator at the Directorate of Research and Development, HQUSACE; Research Area Manager was Mr. Barry Holliday, HQUSACE; and Program Monitors were Mr. Mike Kidby and Ms. Anjana Chudgar, HQUSACE. Mr. William H. McAnally of the ERDC Coastal and Hydraulics Laboratory was the Lead Technical Director for Navigation Systems; Dr. Stanley C. Woodson, ERDC Geotechnical and Structures Laboratory, was the INP Program Manager.

This report was prepared by Dr. Kerry T. Slattery of the Southern Illinois University and Mr. Guillermo A. Riveros of the Engineering and Informatics Systems Division (EISD), ERDC Information Technology Laboratory (ITL). The work was monitored by Mr. Riveros, Principal Investigator of WU 33273, under the supervision of Dr. Charles R. Welch, Chief, EISD; and Dr. Jeffery P. Holland, Director, ERDC ITL.

Commander and Executive Director of ERDC was COL James R. Rowan, EN. Director was Dr. James R. Houston.

# 1 Introduction

---

## 1.1 Background

This report is the user manual for the “Design by Analysis System—Innovative Navigation Structures” (DBAS-INS). The Windows-based computer program creates a solid, three-dimensional (3D) finite element model of innovative structures fabricated using “in-the-wet” construction methods, such as the Braddock Dam currently under construction in the Corps of Engineers’ Pittsburgh District. These structures are initially fabricated as a floating shell in a dry dock. The floating shell is divided into a 2D grid of hollow cells separated by reinforced concrete walls. Most significant structural loads involve hydrostatic pressures on the walls as the segment is floated to the installation site, lowered to the foundation, and filled with tremie concrete. The individual concrete slabs that form the walls of the cells must be designed for shear, moment, and thrust loads caused by the expected load combinations on the structure.

DBAS-INS procedures were developed to assist in the design and analysis of innovative navigation structures by simplifying the steps required to describe a new design, create a finite element model, check all load cases, design the reinforced concrete structure, and study modifications to the design. The DBAS-INS program allows the designer to create an accurate finite element model for a complex, 3D structure and to complete a preliminary layout and design in a fraction of the time normally required. After analysis, the program checks design requirements per ACI 318-02 (American Concrete Institute “Building Code Requirements for Structural Concrete”) and, based on these results, can automatically modify the design and reanalyze the model.

The 3D finite element system includes a powerful preprocessor, a finite element analysis module utilizing conventional shell elements with adaptive superelements, and a postprocessor to perform and check design calculations. This program will allow the designer to quickly develop, analyze, improve, and document designs for innovative navigation structures.

The design by analysis (DBA) session consists of four phases—**Preprocessing, Analysis, Postprocessing, and Modification**. The designer can loop through the last three phases as many times as required to produce an acceptable or optimal design. When the designer is satisfied with the results, a

report is generated showing all reinforcement requirements for the slabs in the structure.

This user's manual discusses each of the four DBA phases in detail, explaining the required inputs with illustrations of the input screens and options available at each step. Two detailed examples are provided in Appendixes A and B, giving step-by-step instructions on the application of the program to typical design problems (floor slab and complete section, respectively).

The design by analysis session is run from the main form of the program, shown in Figure 1.1. Features of the form, which appears as the first screen when the program is opened, are fully described in later portions of this manual. The command buttons are grouped in the Menu Bar along the top, an Outline Design Controls group along the left side, and the View buttons at the lower left.

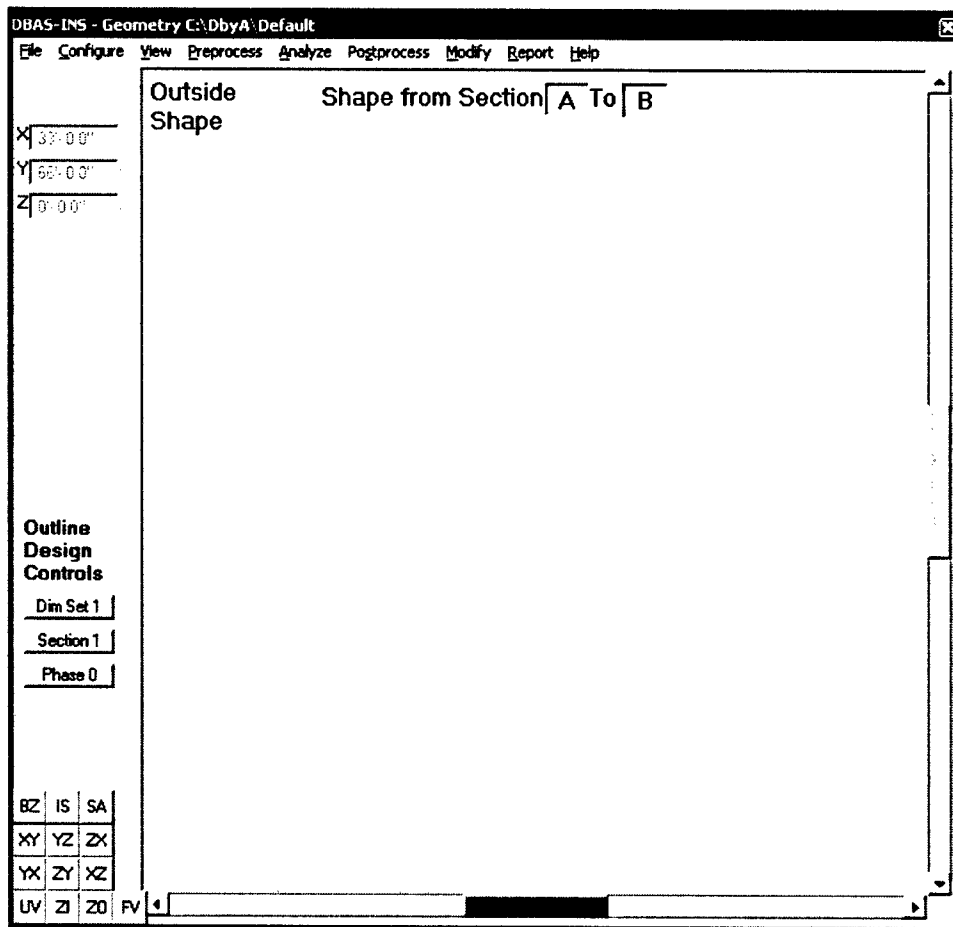

Figure 1.1. Main DBAS-INS form

Required design parameters include the functional design requirements for the navigation structure, primarily the outside dimensions and spillway geometry. The hydraulic engineer must provide this information to the structural designer. The designer can then choose the layout of the diaphragms in the structure considering the constraints of the functional design (e.g., pier locations). It is assumed that the location of diaphragm center lines is consistent throughout each

segment. These will lie on lettered and numbered section lines in the plan view (see, for example, the plan view sketch shown as Figure 1.2). The designer can select the thickness of all diaphragm walls. The thickness must be minimized to reduce weight, but adequate to enclose the reinforcing steel and satisfy the structural requirements. Tapers to eliminate sharp corners at joints between shells must be specified by the designer.

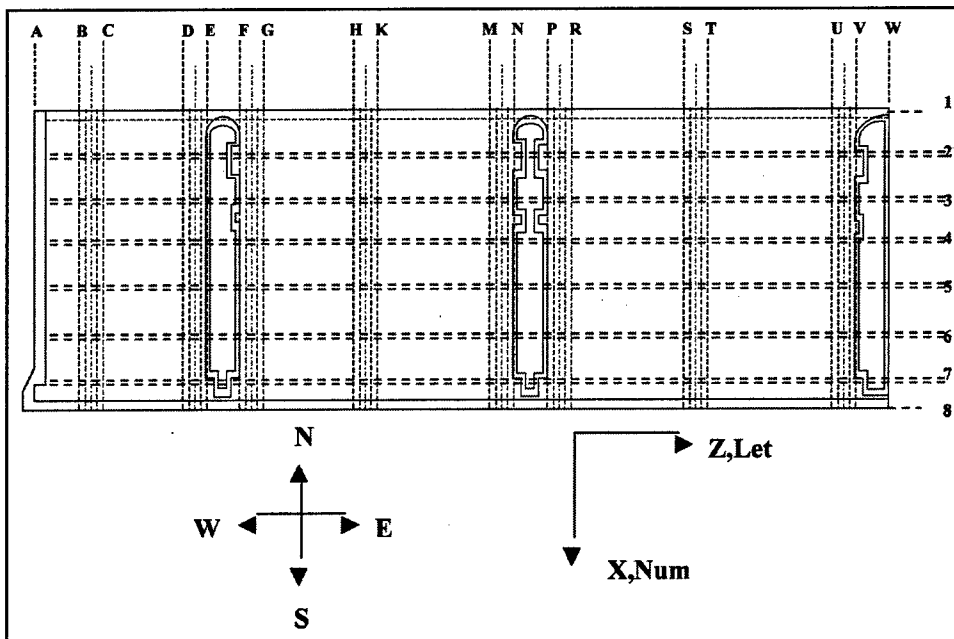

Figure 1.2. Plan view of a dam segment

The designer inputs the location of each diaphragm line to start the **Preprocessing** phase. All models are aligned with the global XYZ coordinate system such that Y is the vertical axis, X is horizontal in the direction of flow, and Z is horizontal and normal to the flow direction. For ease of description, the directions are also referenced to cardinal directions, with “north” being upstream in the XZ plane. Numbered section lines run normal to the direction of flow (in the “west-east” or Z direction). Lettered lines are in the direction of the flow (“north-south” or X direction), as shown in Figure 1.3.

The designer next selects one or more generic spillway layouts, modifies the dimensional parameters to match the hydraulic design, and assigns each spillway shape to a range of lettered sections. A sketch of the cross section is generated to allow the designer to modify other parameters such as wall thickness and corner tapers.

Where there is more than one spillway shape in a segment, a pier wall must be placed between the two spillways. Although two spillway shapes can meet in one pier wall, the DBAS-INS program allows the designer to specify only one of the spillway shapes for the structural model. The designer can input a pier wall height on a lettered section line. A rectangular pier wall is extended from the top surface of the spillway to the designated height. Pier walls on adjacent section lines are enclosed with shell elements.

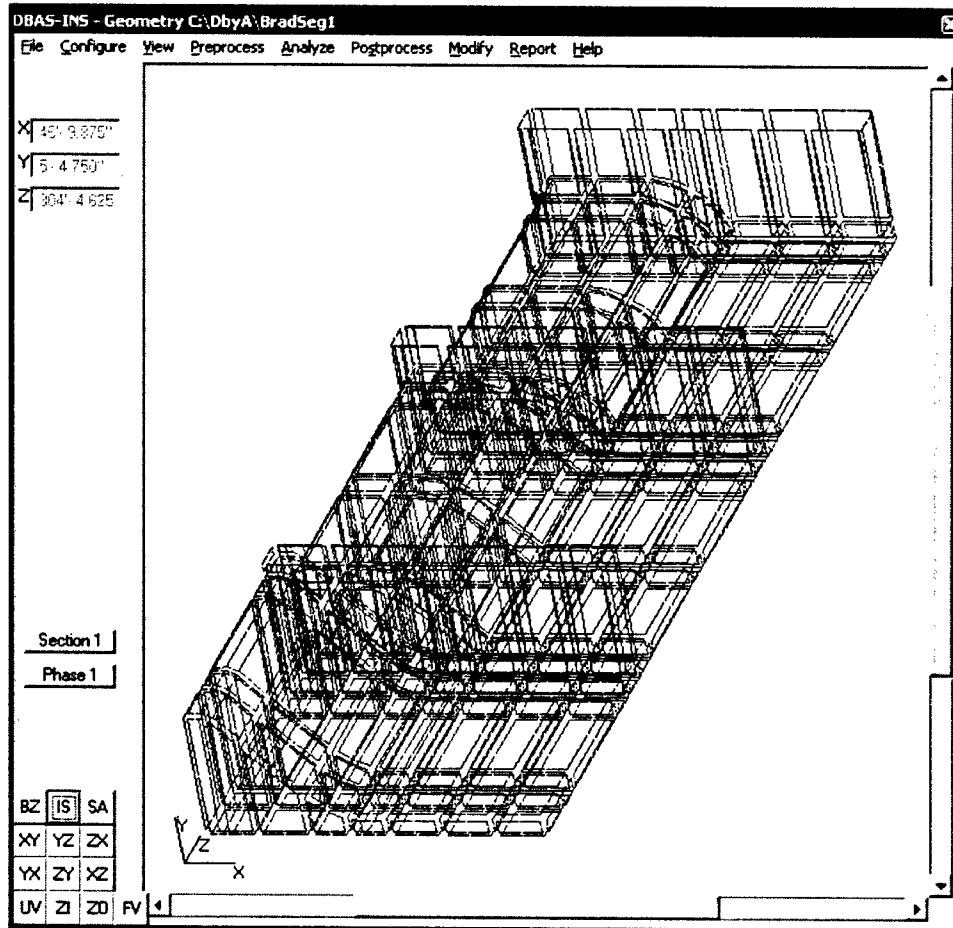

Figure 1.3. Perspective view of model with 3D coordinate system

In the **Analysis** phase, the finite element model is automatically generated based on preprocessor inputs. The concrete panels are modeled using eight-node, 40-degree of freedom (DOF) shell elements. The designer can select the level of refinement as the number of shell elements in each direction in an individual slab or slab segment. This default value must be the same throughout the model in the vertical direction, but the refinement can be modified in either horizontal direction. The shell elements are joined by superelements. An adaptive superelement approach has been developed to quickly generate the necessary matrices to describe the superelement given geometric parameters. A complete description of this development is provided in the DBAS-INS Theoretical Manual (ERDC/ITL TR-03-4).

After generating the model, the designer defines load cases in terms of the fluid level and density in each cell in the structure, concentrated nodal loads, and the restraint condition. Static weight of the structure is included, by default, but may be removed. The finite element equations are then solved to calculate nodal displacements for each load case. Load factors can be applied to the dead load and live loads, per ACI 318-02.

The deflected shape of the structure and the shear, moment, and thrust values in the shell elements can be plotted for each load case in the **Postprocessing**

phase. The design module can then be executed to determine the worst-case design condition in each slab. It will then calculate the required thickness for shear and determine the required reinforcing in each slab. Slabs that are not thick enough to meet the design requirement or that require more reinforcing steel than allowed by ACI 318-02 are highlighted, and a report is generated to output the design for each slab.

In the **Modification** phase the designer can change design parameters in response to analysis results and reanalyze the model. Options are provided to automatically modify the thickness of inadequate slabs or to reduce the thickness of slabs with a high factor of safety for shear and low reinforcement ratio. The model is then recreated and reanalyzed to check the new design.

Once a final design is achieved, the program outputs design information in a tabular format for printing and in a generic graphical format for creating a 3D model in a computer-aided design program. The format is described in Appendix C.

## 1.2 Installation of DBAS-INS

DBAS-INS is loaded by running the Setup program on the CD provided.

## 1.3 Program Organization

All program actions are controlled from the menu bar on the DBAS-INS main form. The succeeding chapters describe each menu option and typical user inputs. The main menu (Figure 1.1) is organized with general program management functions on the left, followed by the commands required to perform operations in each phase, and finally a help option. Additional features of the main form are described in Chapter 4.

The **File**, **Configure**, and **View** menu selections may be used throughout the DBAS-INS session. Some configuration changes require the user to redo some earlier steps, so these should be set early in the session.

The **Preprocess**, **Analyze**, **Postprocess**, and **Modify** phases are executed in order. **Report** generation is typically performed at the end of the session.

## 2 File

---

The **File** menu option, shown in Figure 2.1, allows the user to save the model, access previously stored models, and exit the program.

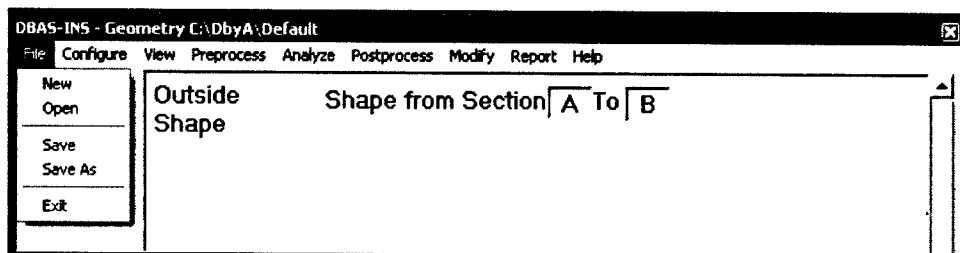

Figure 2.1. File menu option

### 2.1 New

The **New** option backs up the existing model and reinitializes the global variables to begin creating a new model.

### 2.2 Open

The **Open** option prompts the user to select an existing \*.DBA file to continue a previous modeling session.

### 2.3 Save

The **Save** option stores the current model information under the current model name. An up-to-date \*.DBA file is created.

### 2.4 Save As

The **Save As** option allows the user to save the current model under a new file name. The file name is input in the form shown in Figure 2.2.

### 2.5 Exit

The **Exit** option leaves the program. The user is prompted to save the current model.

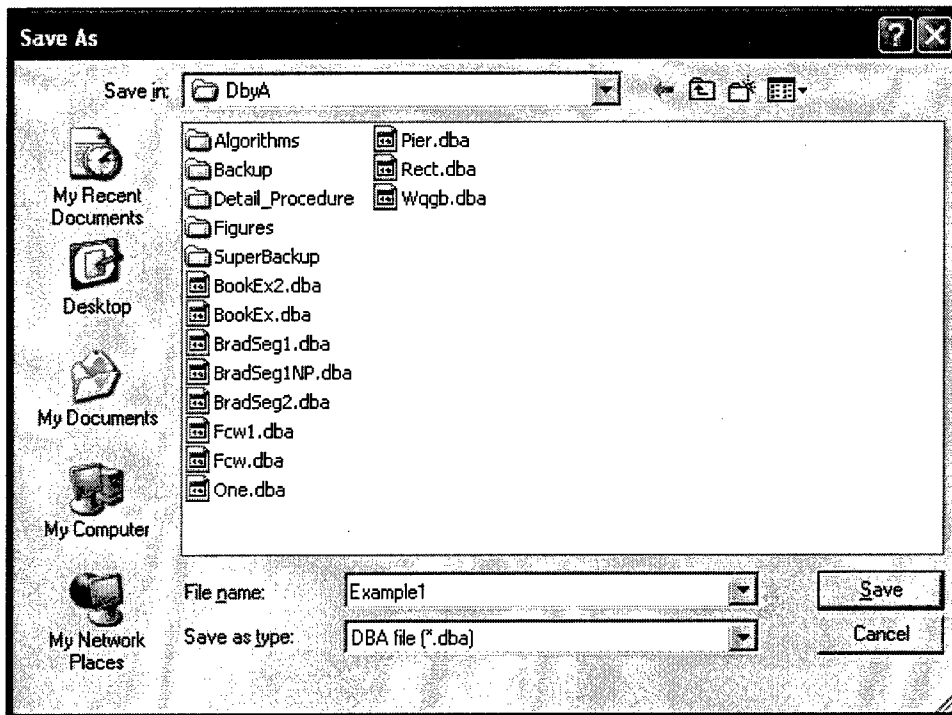

Figure 2.2. Save As form

## 3 Configure

---

Options under the Configure menu item allow the user to modify some modeling parameters. The options are shown in Figure 3.1.

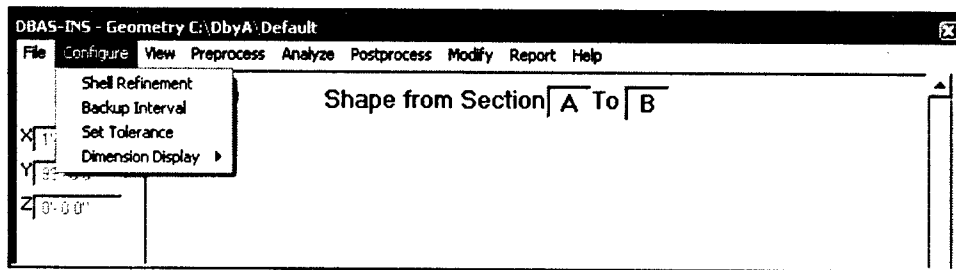

Figure 3.1. Configure menu option

### 3.1 Shell Refinement

Each slab or slab segment in the structure will be divided into an  $M \times N$  grid of eight-node shell elements. A single default value for  $M$  and  $N$  is input in the Shell Refinement form, shown as Figure 3.2. This default value will be the number of elements in the vertical direction in all vertical slabs, although the number of shell elements in the horizontal direction may be changed in the Preprocessing phase. In general, each wall of a single cell in the structure is a slab; however, in some cases the wall must be divided into two or more slab segments in order to model some structural details. The most common example is a lettered section wall, above which the geometry of the spillway consists of two shapes (e.g., a parabola and a straight line). As with any finite element model, the accuracy of the results improves with more elements, but the execution time and required memory also increase. Preliminary models with a refinement of 1 may be executed to check the model, but a level of at least 3 is usually required for adequate accuracy when slabs have lines of inflection in the deflected shape.

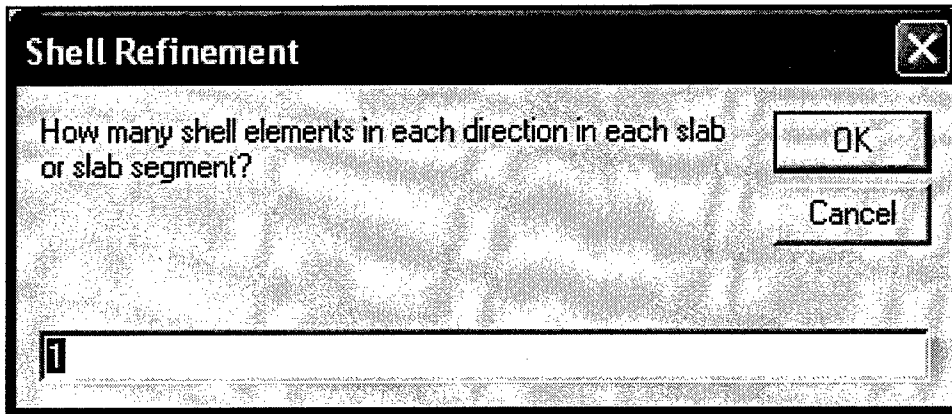

Figure 3.2. Shell refinement

### 3.2 Backup Interval

The program automatically writes all model data to two alternating files, *modelname.ba0* and *modelname.ba1*, at the time interval specified in the **Backup Interval** box. A third backup file, *modelname.dba*, can be created through the Save option in the File menu. The backup frequency can be changed in the **Backup Interval** box, shown as Figure 3.3.

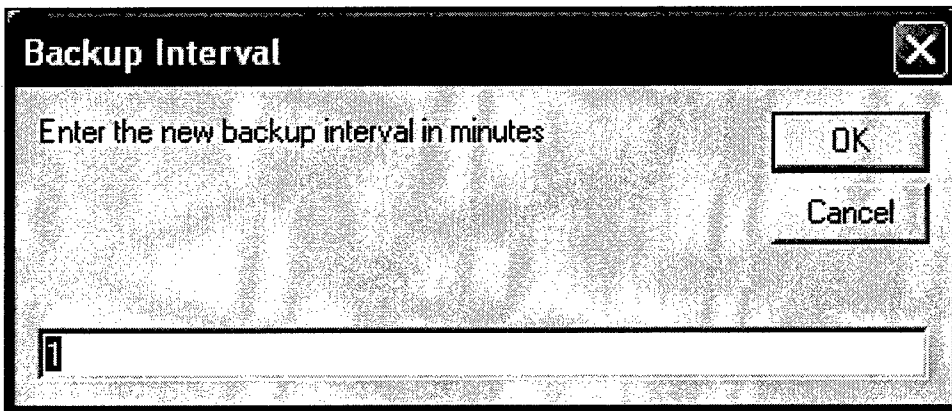

Figure 3.3. Backup interval

### 3.3 Set Tolerance

The tolerance value is used throughout the program to account for small numerical errors in calculations. In most cases, a distance between two points that is less than the tolerance value is considered to be zero. The default value, 0.005 ft,<sup>1</sup> works well for most structures. This value can be changed in the **Set Tolerance** box, shown as Figure 3.4.

---

<sup>1</sup> A table of factors for converting non-SI units of measurement to SI units is presented on page viii.

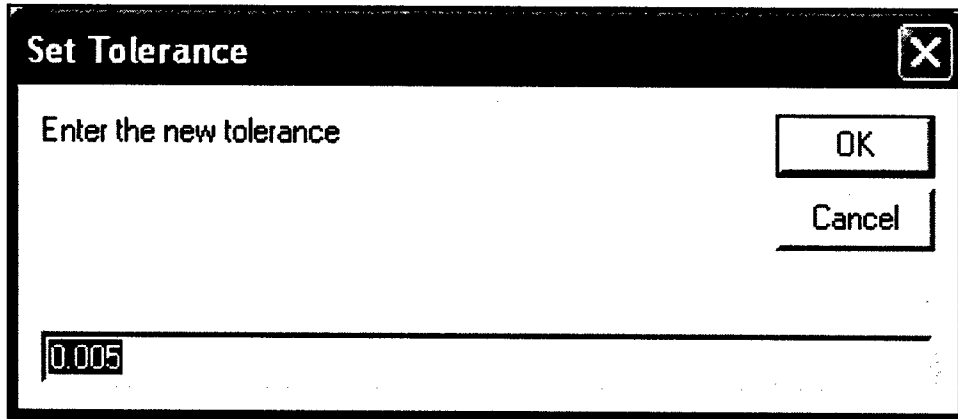

Figure 3.4. Set tolerance

### 3.4 Dimension Display

All parts of the program except the design procedures will produce valid results as long as consistent units are used for length and force. However, some input and output options are easier to use if non-SI (English) length values can be input as feet and inches. It is expected that the user will work in non-SI units. Numerical inputs are formatted for feet and inches, which can be entered with or without the foot and inch signs, separated by a dash (e.g., 1"-4" or 1-4). This option can be turned off by selecting Decimal, as shown in Figure 3.5.

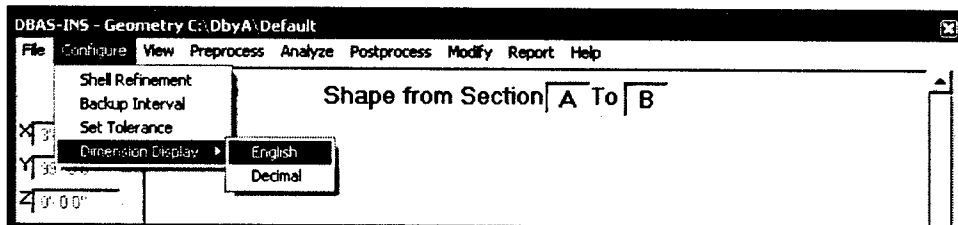

Figure 3.5. Dimension display option

## 4 View

---

The View option shown in Figure 4.1 is used to control the plot that is displayed on the screen and to generate additional visual renderings of the model and finite element results. Many options are also available as command buttons in the lower left corner of the DBAS-INS form. Tool Tips appear when the mouse passes over a button to describe the orientation of the view in terms of the cardinal directions.

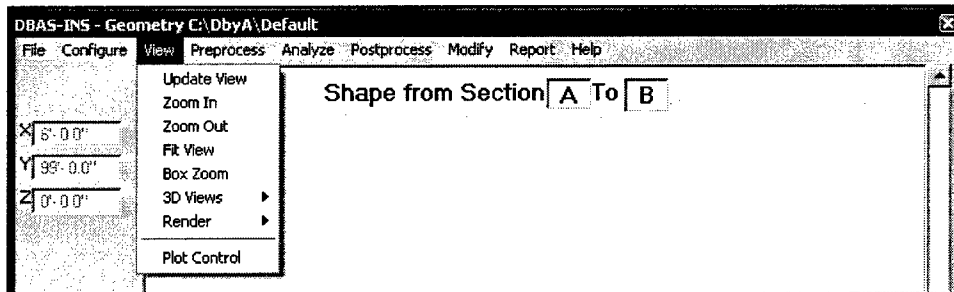

Figure 4.1. View option

The XYZ coordinate system is aligned such that Y is the vertical axis, X is horizontal in the direction of flow, and Z is horizontal and normal to the flow direction. The coordinate axes are shown on the model plotted in Figure 1.3. Coordinates of the current cursor position are shown in the X, Y, and Z boxes in the upper left-hand corner of the form.

### 4.1 Update View (UV)

The **Update View** command redraws the model using the current window settings.

### 4.2 Zoom In (ZI)

The **Zoom In** command resizes the drawing and updates the plot. The center point remains fixed in the view, and the drawing scale is enlarged by the **Zoom Factor** specified on the **Plot Control** form (default is 2.00).

### 4.3 Zoom Out (ZO)

The **Zoom Out** command resizes the drawing and updates the plot. The center point remains fixed in the view, and the drawing scale is reduced by the **Zoom Factor** specified on the **Plot Control** form (default is 2.00).

### 4.4 Fit View (FV)

The **Fit View** command adjusts the scale of the drawing so that the entire model fits in the view window. Fit View is automatically executed whenever the view angle changes.

### 4.5 Box Zoom (BZ)

The **Box Zoom** command allows the user to specify a new window by selecting opposite corners of a rectangle in the current view that encloses part of the model. After clicking the command button, the user selects one corner by a left-mouse button click on the plot. A red rectangle is formed around the selected region as the mouse is moved. A second left click selects the desired area. The results of the **Box Zoom** being executed (Figure 4.2) are shown in Figure 4.3.

### 4.6 Three-Dimensional Views (XY, YX, YZ, ZY, ZX, XZ, IS, SA)

Seven preset **3D Views** are available as shown in Figure 4.4. The final option, **Set Angle (SA)**, allows the user to select angles from which to plot the view. The first six preset views are labeled such that the first letter designates the coordinate axis that is aligned with the horizontal direction in the plot. The second letter is the vertical axis. The direction is also described in the menu and by a **Tool Tip** on the command button to identify the cardinal direction with respect to the structure, assuming that the water flows from north to south. The **IS** option plots an **isometric** view from a predefined angle.

The **View Rotation** form, shown in Figure 4.5, appears when the **Set Angles** option is chosen. The current view angles are displayed. New values may be entered in the text boxes, or values may be adjusted using the scroll bars. The view is updated when the **Apply** button is clicked.

### 4.7 Render

The **Render** options shown in Figure 4.6 create 3D renderings of the model. The **Solid** option plots stresses on the exposed faces of the model. The other options are used in the **Postprocessing** phase to view shear (**V1**, **V2**), moment (**M1**, **M2**), and thrust (**T1**, **T2**) results on the shell elements.

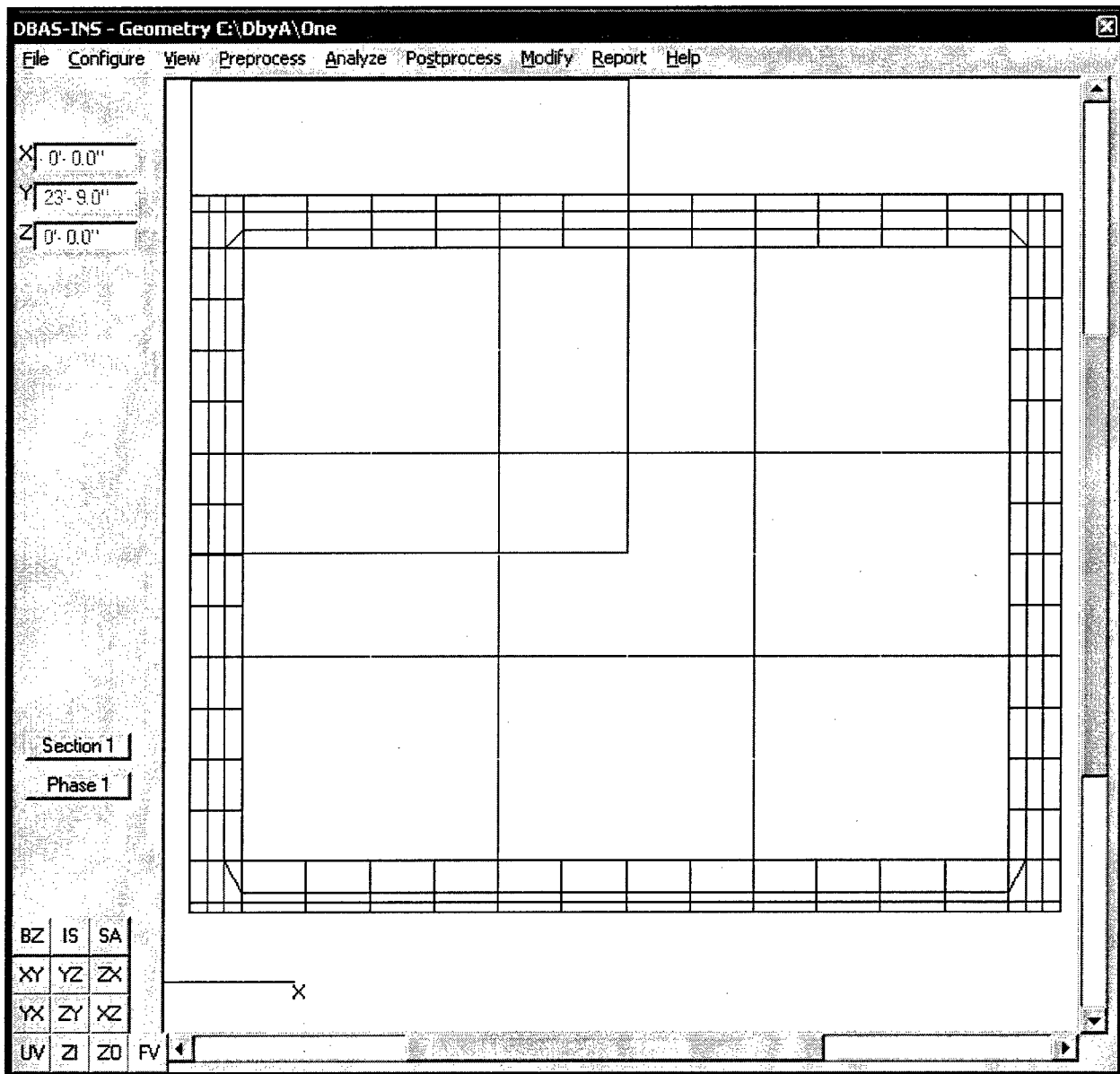

Figure 4.2. Box Zoom selection

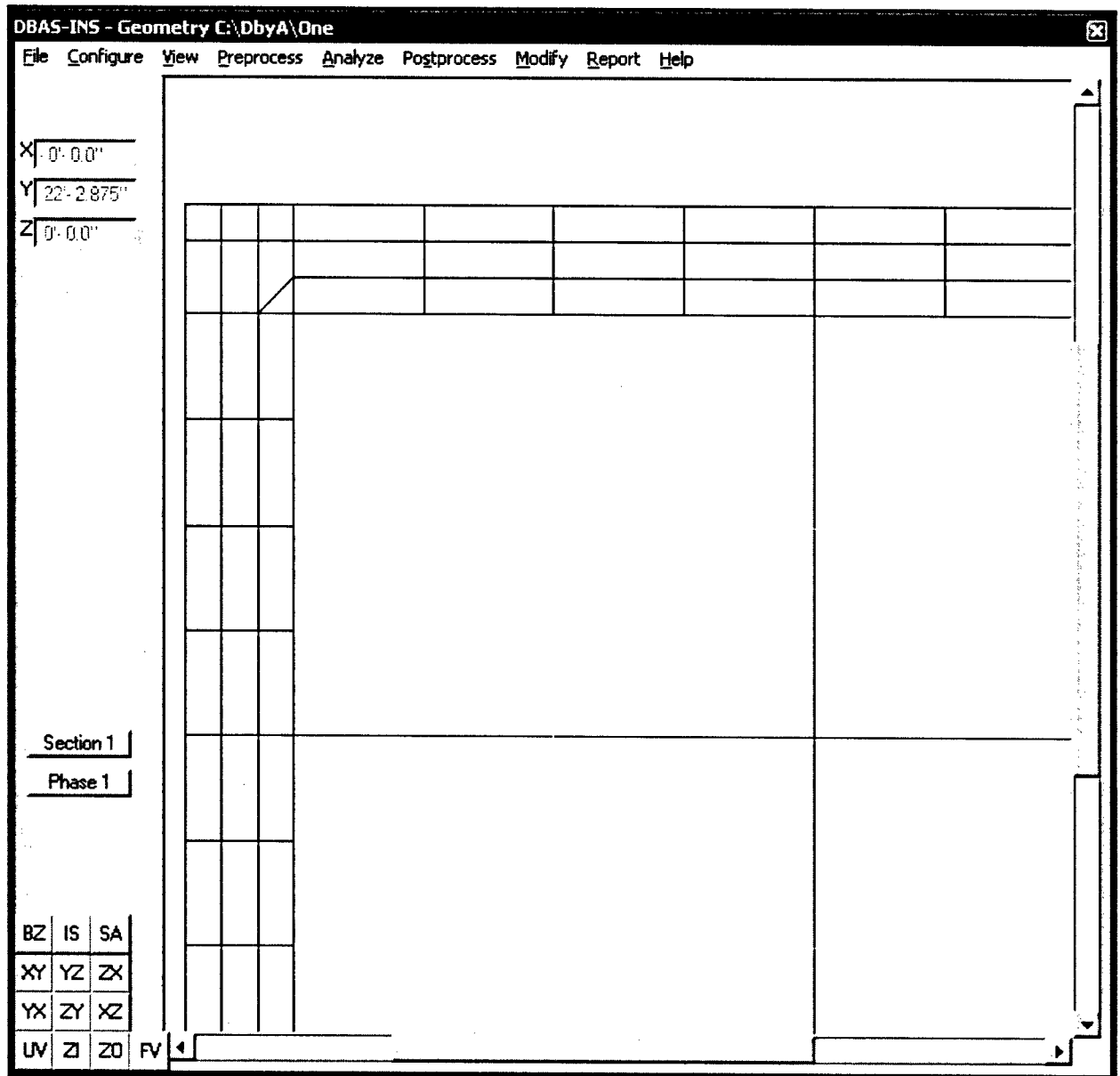

Figure 4.3. Box Zoom results

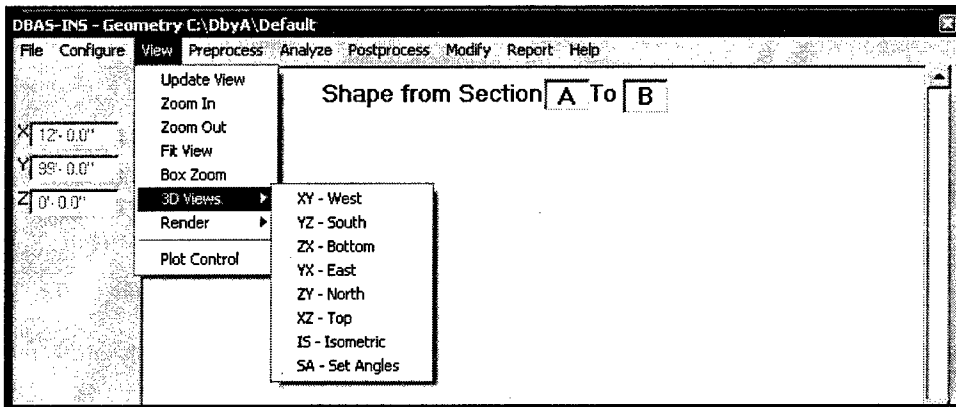

Figure 4.4. Three-dimensional view options

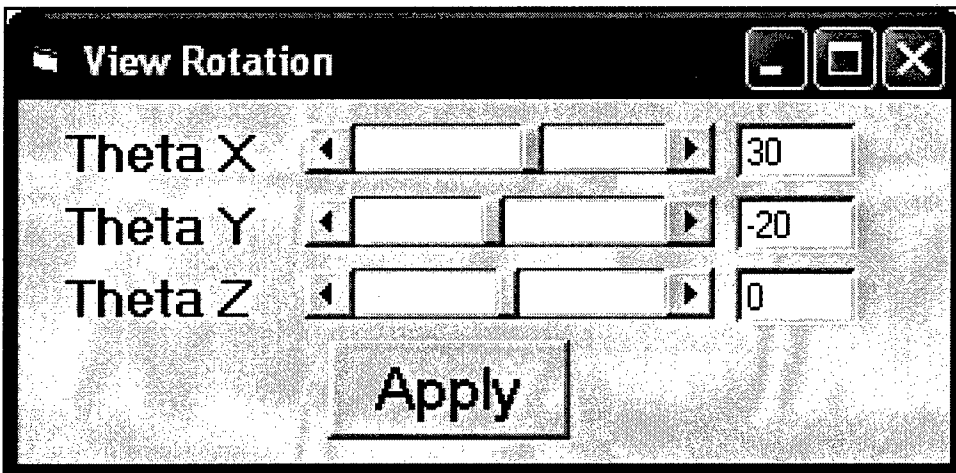

Figure 4.5. View rotation form

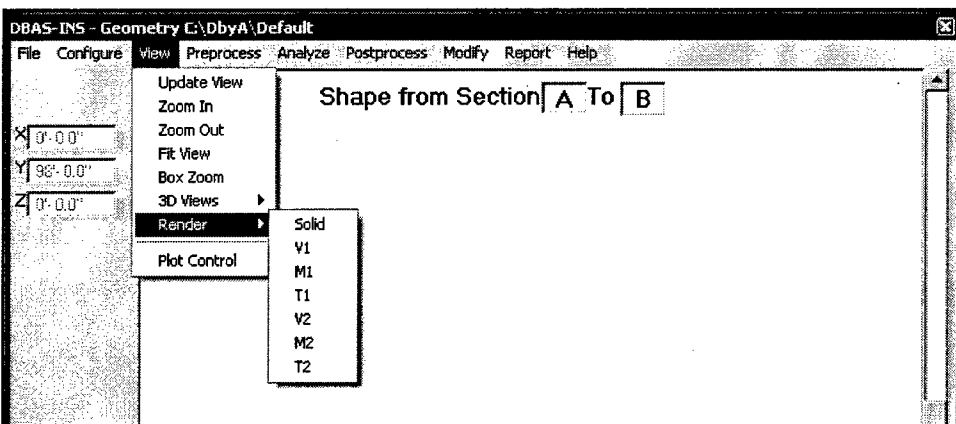

Figure 4.6. Render options

The Rendering form shown in Figure 4.7 shows stress results on the outside of a spillway structure. The user can either let the program automatically assign the range of stress values or change the **Minimum** and **Maximum** value in the text boxes above and below the color bars. The plotted **Component** can also be

changed, and the view will be automatically updated. The view plotted in the Rendering is controlled by the view setting on the main DBAS-INS form. The rendering is always plotted in an undeformed condition.

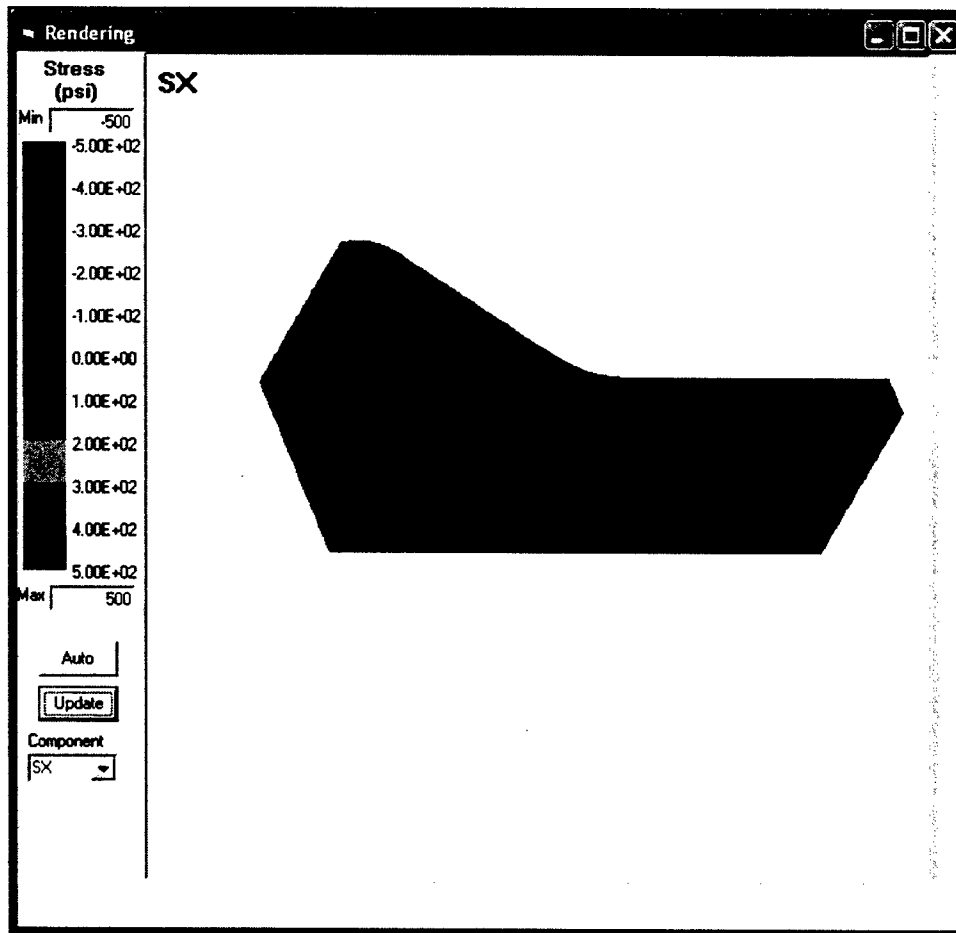

Figure 4.7. Rendering of stresses

## 4.8 Plot Control

The **Plot Control** form, shown in Figure 4.8, sets plotting parameters for all plots after the finite element model is generated. Element types can be turned on by checking the appropriate **Elements** box. (The **Zoom Factor** is explained in Section 4.2.) Curved shell element boundaries can be plotted as a series of small line segments by checking **Plot Curves**. The default is to plot the element side as two lines connecting the midside node to the corners nodes. The **Curve Refine** parameter is the number of segments that make up a curve. Larger values require more time to update the plot. Checking the **Node Numbers** box displays on shell node numbers.

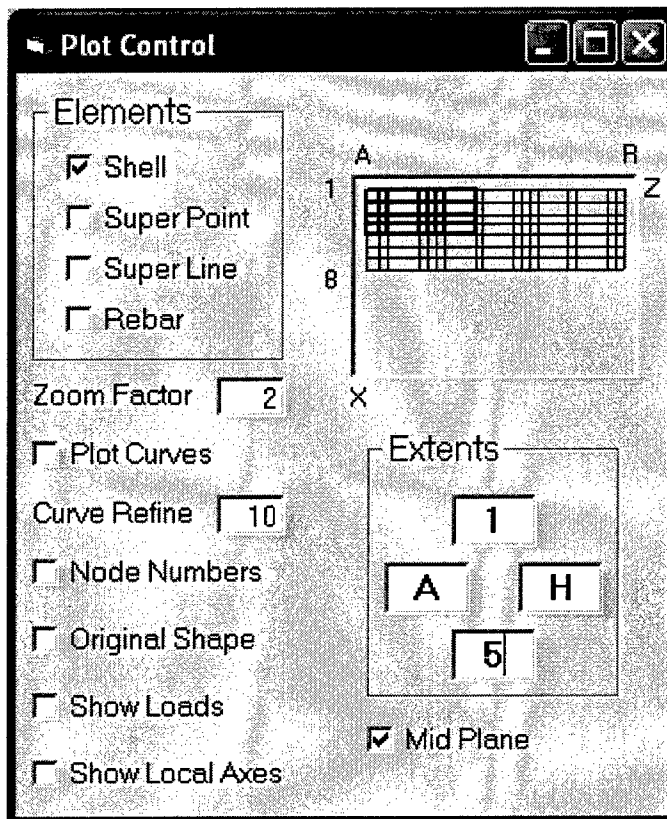

Figure 4.8. Plot control form

When viewing analysis results, the default plot shows the deformed shape with actual deflections magnified by a user-input factor. A plot of the original shape can be superimposed on the model by checking the **Original Shape** box. The water or tremie concrete levels in the structure are plotted when the **Show Loads** box is checked. Local, numbered axes are plotted on shell elements or in the lower left-hand corner in the Rendering view when **Show Local Axes** is checked.

A segment of the model to be plotted can be designated by inputting the section lines surrounding the desired region in the **Extents** box. The selected region is highlighted in red in the miniature plan view. The minimum and maximum section numbers and letters are displayed to the left of and above the plot. The X and Z axes are also labels. Figure 4.9 shows the plot of the model in Figure 1.3 with the options as shown in Figure 4.8. **Mid Plane** should be checked to plot stress contours midway between section lines. This option is discussed in more detail in Section 7.

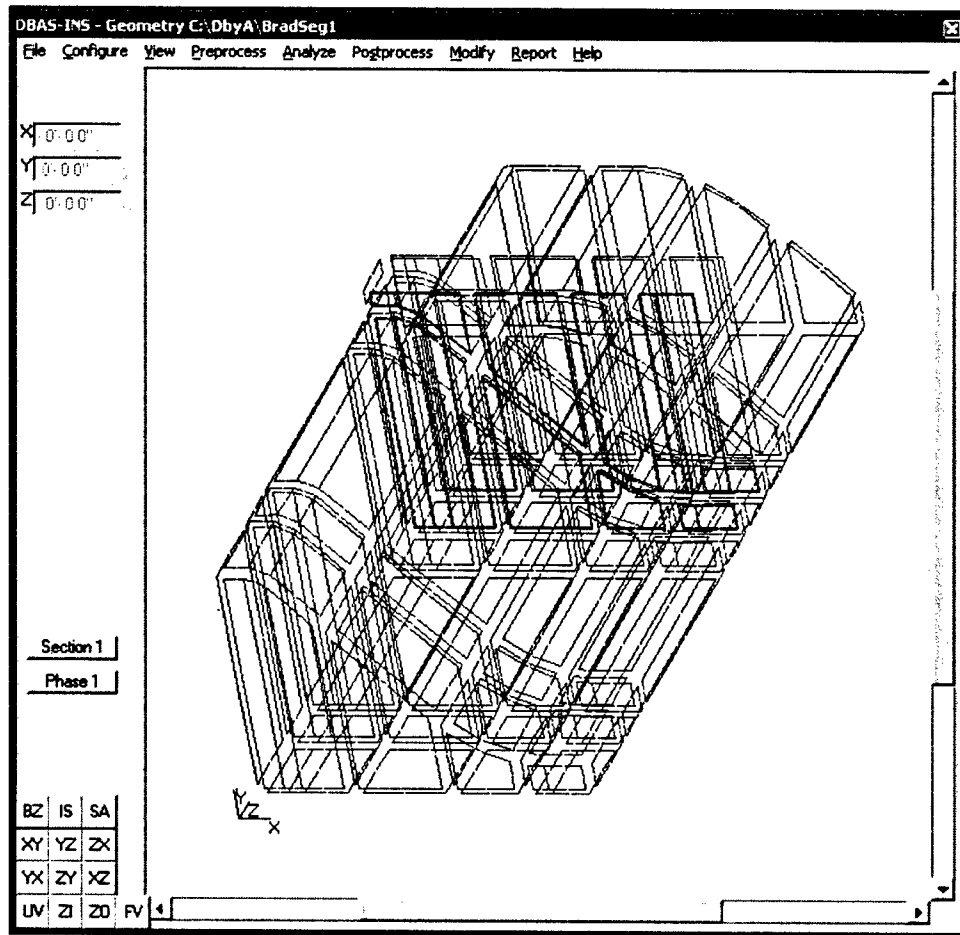

Figure 4.9. Results with selected plot options

# 5 Preprocess

The **Preprocess** option shown in Figure 5.1 guides the layout of the structure and generation of the finite element model. The preprocessing phase begins with the designer laying out the section lines in the plan view. Numbered sections run perpendicular to the flow direction. This is the Z direction in the model. Lettered sections are in the X direction, and Y is the vertical axis. After the diaphragm layout is defined, the designer draws the outline of each unique spillway section in the segment by adjusting parameters in predefined templates and assigns the shape to a range of lettered sections. In the final step, the finite element model is automatically generated based on the model description.

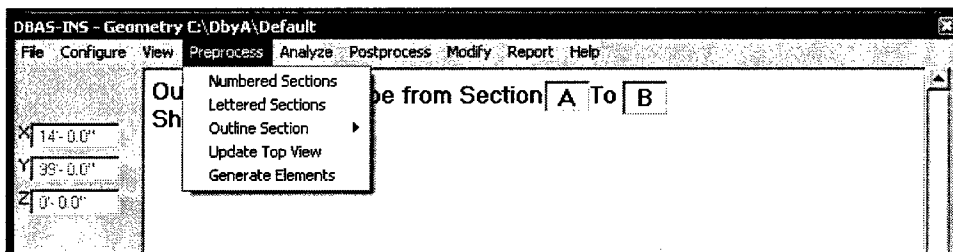

Figure 5.1. Preprocess option

## 5.1 Numbered Sections

The designer begins to create the model by describing the location of each numbered section under the **Preprocess | Numbered Section** menu item. The user is prompted to input the number of numbered section lines (Figure 5.2) and the width of the segment (Figure 5.3). The form shown in Figure 5.4 allows the user to input the coordinate of the center of each section in the X Coord column. The default thickness is 1 ft. The center of the first and last sections is one half the section thickness from the end. The shell refinement can be adjusted for each cell by changing the default value in the **Shell RefN** column. The values are the number of shell elements between the section lines.

The values input in Figure 5.4 are for the segment depicted in Figure 1.2. Figure 5.5 is a plot of the shell elements for a spillway section with a default shell refinement of 3 (Figure 3.2) but with the Shell RefN values set as shown in Figure 5.6.

**Numbered Sections** [X]

How many numbered section lines?

OK

Cancel

8

Figure 5.2. Number of Numbered Section lines

**Segment Width** [X]

How wide is the segment?

OK

Cancel

104.5

Figure 5.3. Width of the segment

**Numbered Section Coordinates** [-] [ ] [X]

	X Coord	Thickness	Shell RefN
1	0'-6.0"	1'-0.0"	
2	16'-6.0"	0'-10.0"	1
3	32'-6.0"	0'-10.0"	1
4	44'-3.0"	0'-10.0"	1
5	56'-0.0"	1'-0.0"	1
6	72'-0.0"	1'-0.0"	1
7	88'-0.0"	1'-0.0"	1
8	104'-0.0"	1'-0.0"	1

OK

Cancel

Figure 5.4. Numbered Section Coordinates form

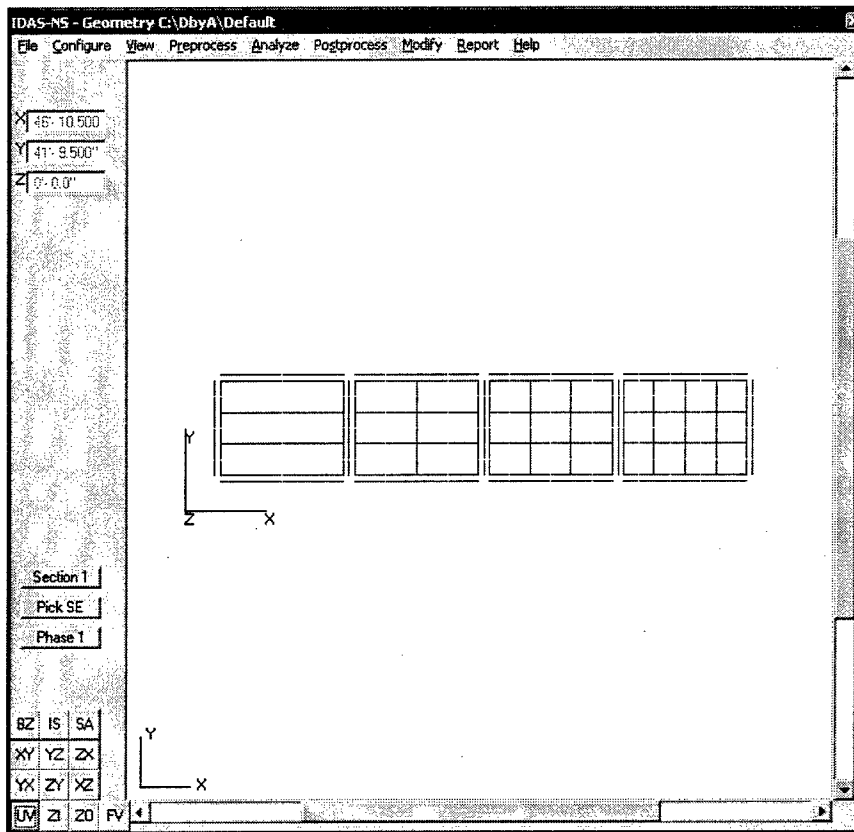

Figure 5.5. Shell elements for simple rectangular model

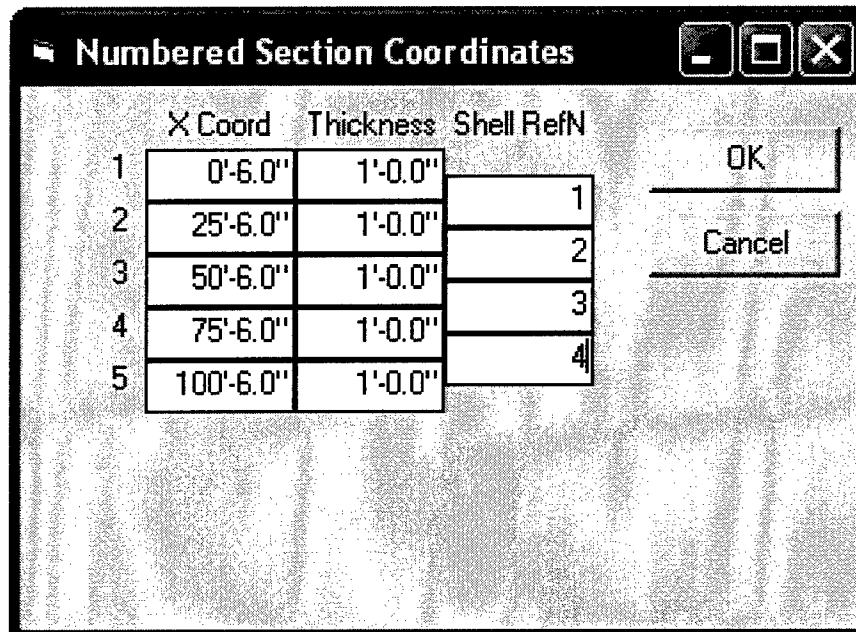

Figure 5.6. Modified shell RefN values

## 5.2 Lettered Sections

Lettered section locations are entered in the same way as numbered sections. The spaces between lettered sections are considered to be in the Z direction in the model. The user is prompted for the number of sections and the length of the segment. Default values are then assigned based on equal spacing of sections. Spacing can be modified by changing the Z coordinates at the centers of the segments in the form shown in Figure 5.7.

	Z Coord	Thickness	Shell RefL	Pier Height
1	0'-6.0"	1'-0.0"		0'-0.0"
2	16'-0.0"	1'-0.0"	1	0'-0.0"
3	26'-0.0"	1'-0.0"	1	0'-0.0"
4	67'-6.0"	1'-0.0"	1	0'-0.0"
5	78'-6.0"	1'-0.0"	1	42'-3.625"
6	89'-6.0"	1'-0.0"	1	42'-3.625"
7	100'-6.0"	1'-0.0"	1	0'-0.0"
8	140'-0.0"	1'-0.0"	1	0'-0.0"
9	150'-0.0"	1'-0.0"	1	0'-0.0"
10	189'-6.0"	1'-0.0"	1	0'-0.0"
11	200'-6.0"	1'-0.0"	1	42'-3.625"
12	211'-6.0"	1'-0.0"	1	42'-3.625"
13	222'-6.0"	1'-0.0"	1	0'-0.0"
14	262'-0.0"	1'-0.0"	1	0'-0.0"
15	272'-0.0"	1'-0.0"	1	0'-0.0"
16	311'-6.0"	1'-0.0"	1	0'-0.0"
17	322'-6.0"	1'-0.0"	1	42'-3.625"
18	333'-6.0"	1'-0.0"	1	42'-3.625"

Figure 5.7. Form to enter location of lettered sections

The values input in Figure 5.7 are for the segment depicted in Figure 1.2. The Lettered Section Coordinates form is also used to identify the location and height of pier walls, as shown. A non-zero value in the Pier Height column indicates a pier wall at that section line. Pier walls should be paired on adjacent section lines, since the program will generate elements to enclose the pier on the upstream and downstream face of the segment. A single pier wall may be placed on the first or last section.

## 5.3 Outline Section

The next step is to define the 2D cross section of the spillway(s) in the dam segment. Spillway geometry is defined by selecting a template for the outline. The program sets the length of the section and the diaphragm locations based on earlier inputs. The adjustable dimensions are divided in three sets for clarity. The first set is the parameters needed to describe the outside shape of the section. The second set is thickness values, and the third set is taper designations. Command buttons are available on the left side of the DBAS-INS form to control these and other design options, as shown in Figure 5.8.

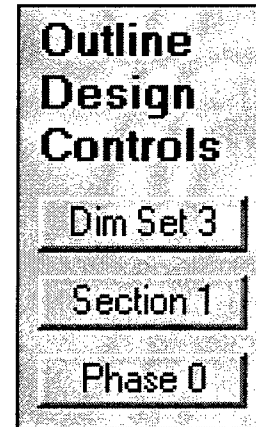

Figure 5.8 Outline design controls

### 5.3.1 Spillway templates

Four spillway templates are currently available:

- Fixed-crest weir.
- Water quality gate bay.
- Standard gate bay.
- Rectangle.

Figures 5.9-5.12 are sketches showing the dimensions that may be adjusted by the designer to meet the requirements for the segment. Changes to the outside geometry are reflected in subsequent plots of the section. The position and thickness of diaphragms are based on inputs described in Sections 5.1 and 5.2 above. The predetermined length of the spillway was defined in the Segment Width form (Figure 5.3).

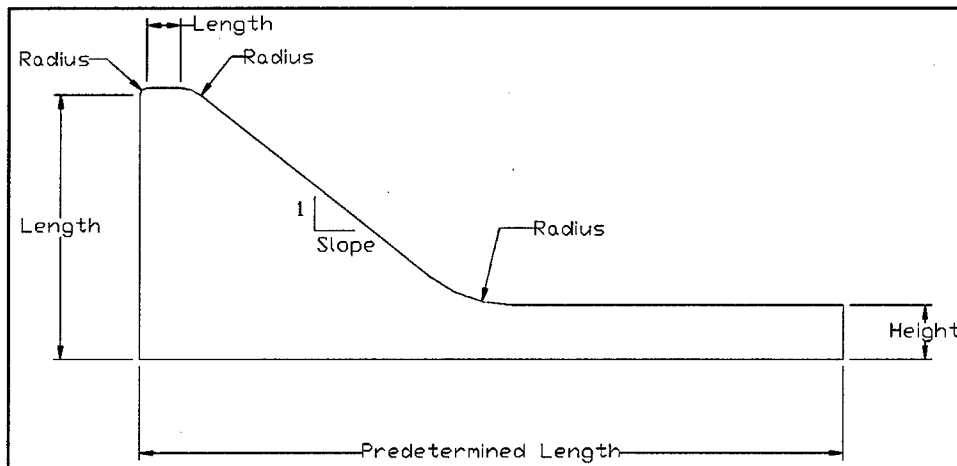

Figure 5.9. Fixed-crest weir template parameter definition

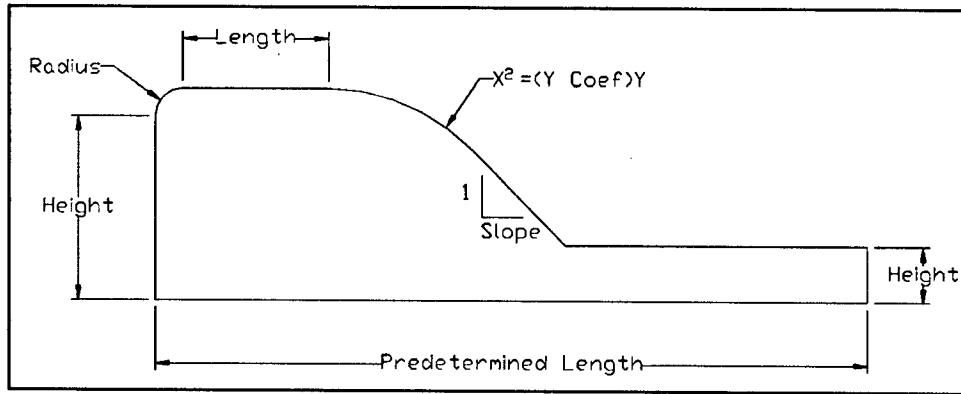

Figure 5.10. Water quality gate bay template parameter definition

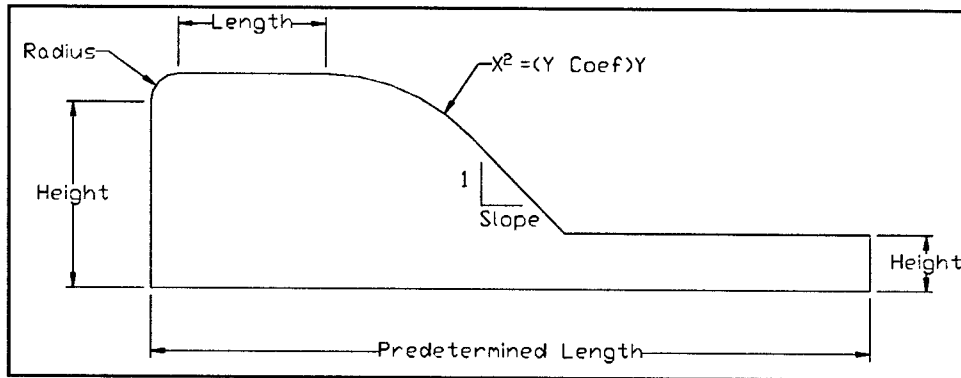

Figure 5.11. Standard gate bay template parameter definition

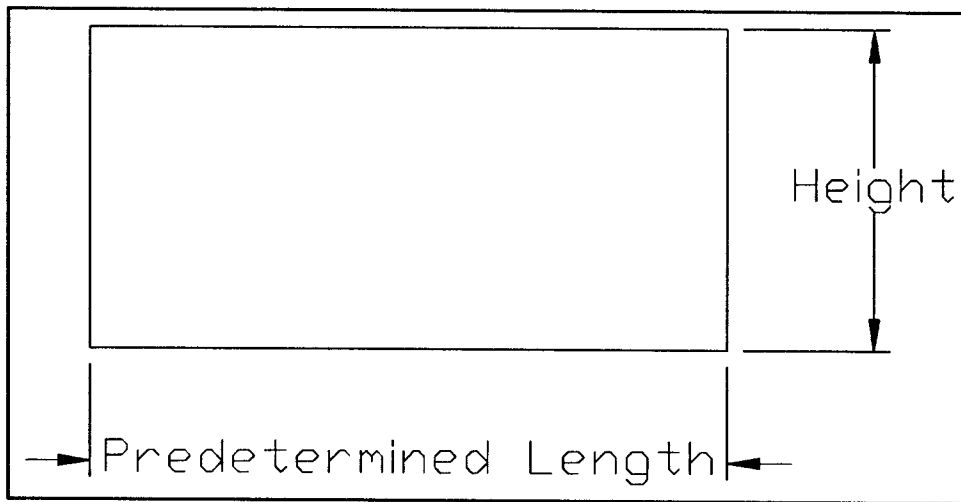

Figure 5.12. Rectangular template parameter definition

### 5.3.2 Dimension sets

The user can access other Dimension Sets by clicking the **Dim Set *n*** button shown in Figure 5.8. New text boxes are displayed on the plot to allow other inputs.

**5.3.2.1 Outside shape.** The outside shape of the section is controlled by parameters available in Dimension Set 1. These are labeled and are different, in general, for each spillway type. The parameters shown in Figure 5.13 are for a fixed-crest weir. Figures 5.14-5.16 show spillway geometry parameters for other available templates.

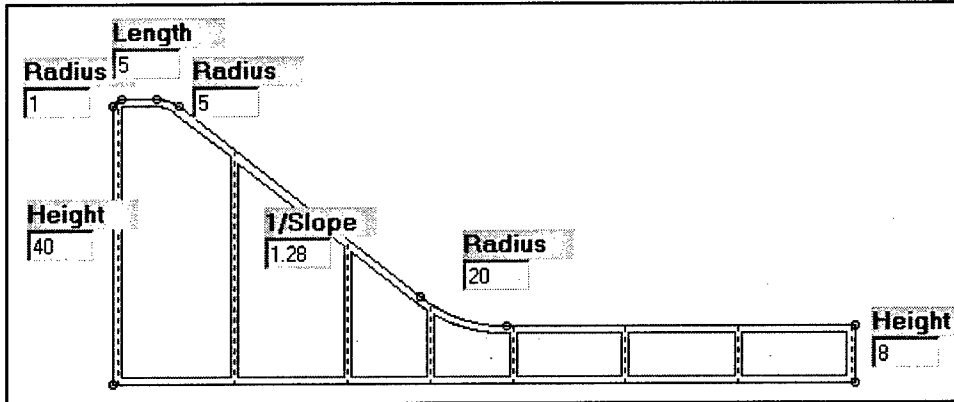

Figure 5.13. Fixed-crest weir outside shape parameters

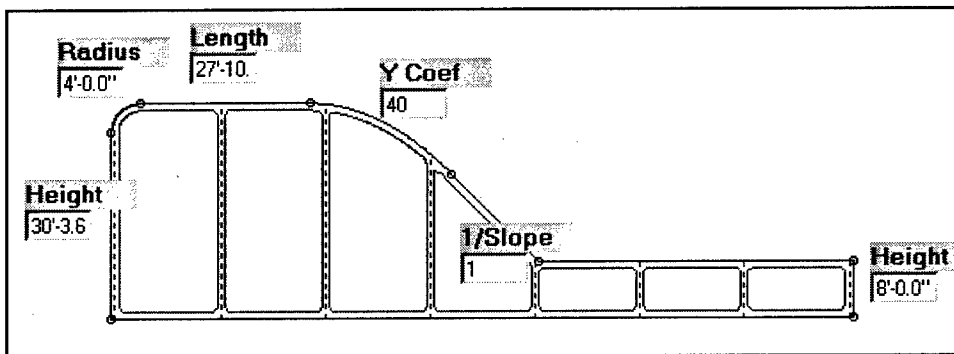

Figure 5.14. Water quality gate bay outside shape parameters

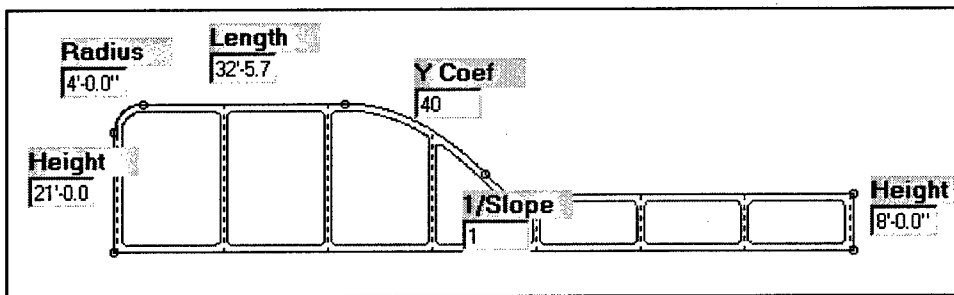

Figure 5.15. Standard gate bay outside shape parameters



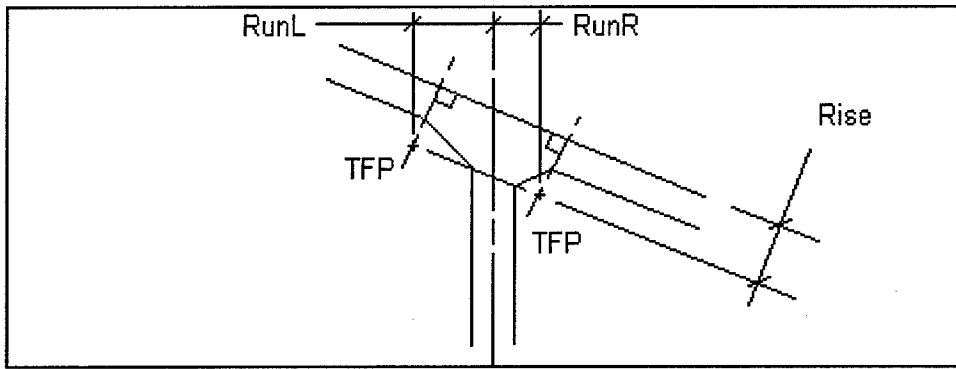

Figure 5.18. Taper dimension definition

Taper Numbers are defined in the Taper Types form, shown in Figure 5.19. The Run and Rise are input in inches. The Add button is clicked to store the definition. The program forces adjacent vertical tapers to be consistent; that is, the run must be the same for both the top and bottom taper on one side of a diaphragm wall. Only one rise value is permitted along the bottom surface. Different rise values may be applied to tapers on the top. Taper Numbers will be automatically changed to enforce these rules. More modeling flexibility will be permitted as more detailed superelements are developed in subsequent releases of DBAS-INS. Taper number assignments are shown in Figure 5.20.

Number	Run(in.)	Rise(in.)
0	12	18
1	12	24
2	18	24
3		

**Add**

Figure 5.19. Taper Types form

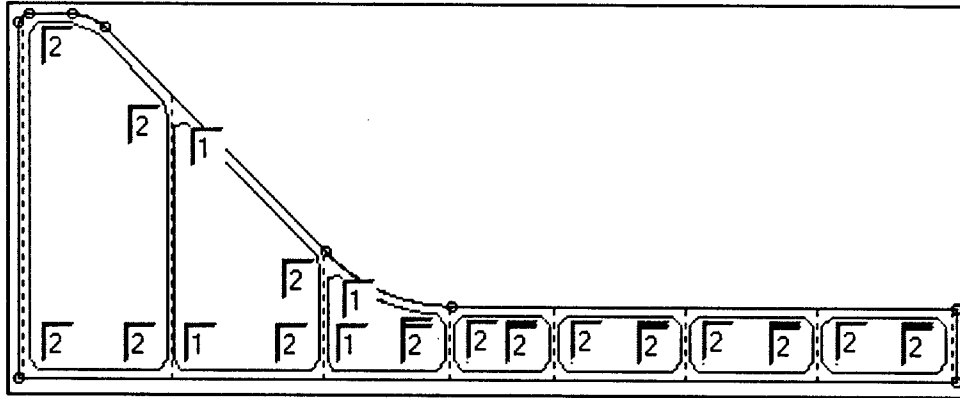

Figure 5.20. Fixed-crest weir taper parameters

### 5.3.3 Section number

A single dam segment may have more than one spillway. The designer creates additional spillways by selecting a new template from the **Preprocess | Outline Section** menu item. The user must designate the range of lettered sections with this spillway geometry using the **Shape from Section A to B** entries at the top of the sketch (see Figure 1.1). The designer can scroll through the different sections by clicking the **Section *n*** button.

### 5.3.4 Phase

The DBA session is divided into distinct phases. The type of information that is plotted is different in each phase. Phase 0 is the preprocessing phase that takes place before finite elements are generated. The user will switch to the analysis phase, Phase 1, after generating the finite elements. Postprocessing is performed in Phase 2. The designer can plot stress contour on cross sections of the model and calculate and plot shear, moment, and thrust diagrams. It is possible to return to a previous phase by *right-clicking* the Phase button; however, switching from Phase 1 to Phase 0 is not recommended since information generated in Phase 1 may be lost or made invalid.

## 5.4 Update Top View

The section layout can be modified and verified by updating the top view (Figure 5.21). The **Top View** form displays information about the individual slabs in the model. The slab thicknesses can be modified in this form when the **Display | Thickness/Run** option is selected. The values for the Bottom, Top, Number, and Letter walls are shown in color-coded text boxes (see the Key). Number and Letter refer to the section line of the vertical wall.

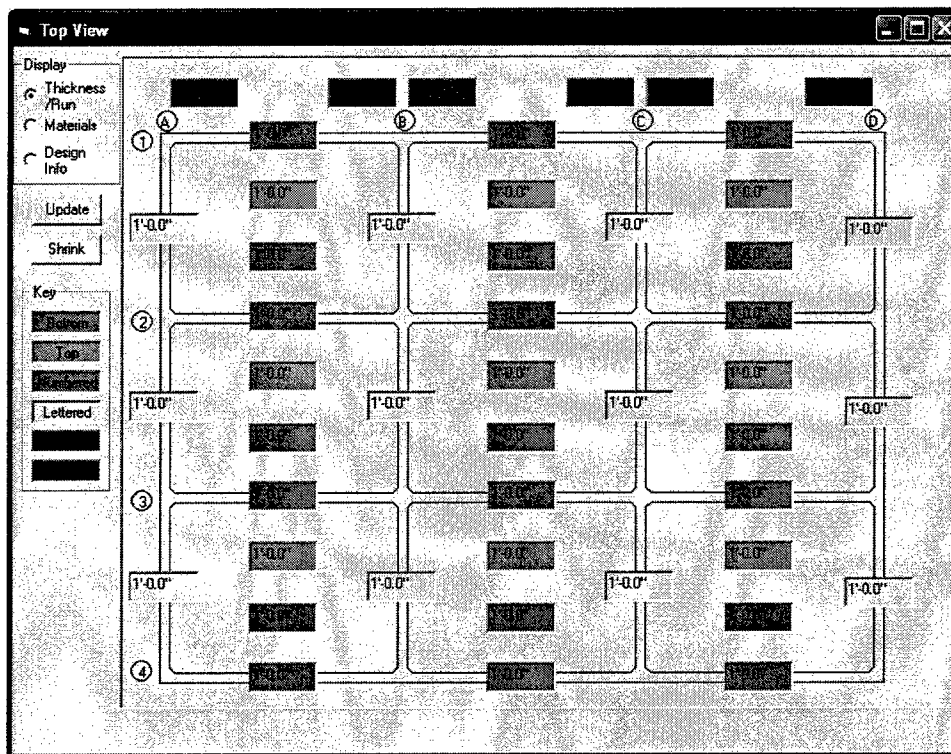

Figure 5.21. Top view shows section line/diaphragm locations

Some taper properties can also be modified in the form. The run and rise of the taper along a numbered section line is set in the section layout discussed above. The run in the E-W direction can then be modified by changing the value in the Run Left and Run Right boxes at the top of the Top View form. The length is applied to all tapers on the designated (left or right) side of the lettered section line. This form will be crowded if a detailed model is being developed and the user attempts to display the entire model. In this case, the Extents values on the Plot Control form (Figure 4.8) should be adjusted to plot a smaller region of the model.

Material property designations can also be modified in the Top View by selecting the Display | Materials option, as shown in Figure 5.22. Default material names are assigned to slabs based on their location in the model. The properties are assigned as described in Section 6.1. The user can change the properties of an individual slab by clicking the text box and selecting from the defined materials. In Figure 5.22, the properties of the Top slab element in the middle of the model are being changed.

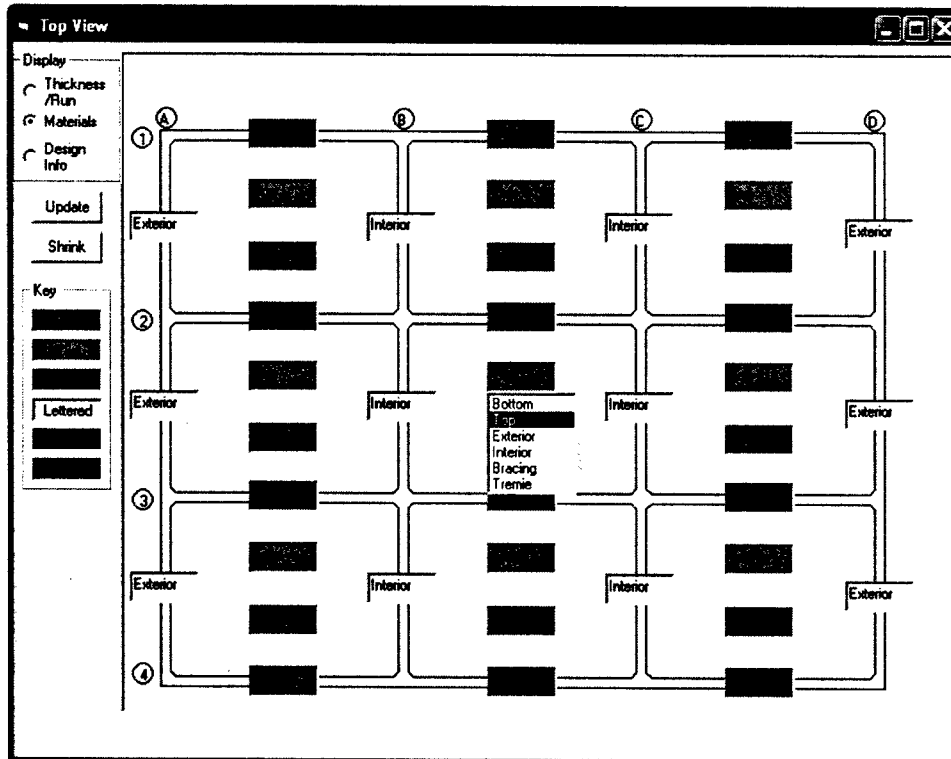

Figure 5.22. Material assignments

The **Update** button on the form replots the sketch after changes are made to the desired output. The **Shrink** button reduces the size of the text boxes so that a larger portion of the model can be displayed, as shown in Figure 5.23. This is useful when reviewing design details, since no information is displayed in the box; it is simply a location to click to request the data.

After analysis, the Top View can be used to display design information for the individual slabs. The user simply clicks on the corresponding text box, and details of the slab design are displayed, as shown in Figure 5.24. The results in the figure are for Bottom Slab 2B. The number designation for top and bottom slabs is the section lines at the upper left-hand corner (NorthWest). Bottom Slab 2B is bounded by section lines 2, B, 3, and C. The rho values are the steel ratios required in the slab in each of four layers. The directions, 1 and 2, are the local axes of the slab as defined in Section 7.2. The signs “+” and “-” refer to the direction of the moment. The + steel is on the bottom to resist positive moment, and the - steel is on the top. RhoMin is the required temperature steel and is based on the full thickness of the slab. The total steel in a given direction must be greater than RhoMin. RhoMax is 75 percent of the balance steel ratio for flexure, as required by ACI 318. The Shear Factor of Safety is the factored shear load divided by the allowable shear strength. This value should be greater than 1. Tmin is the minimum thickness (in feet) to satisfy serviceability requirements.

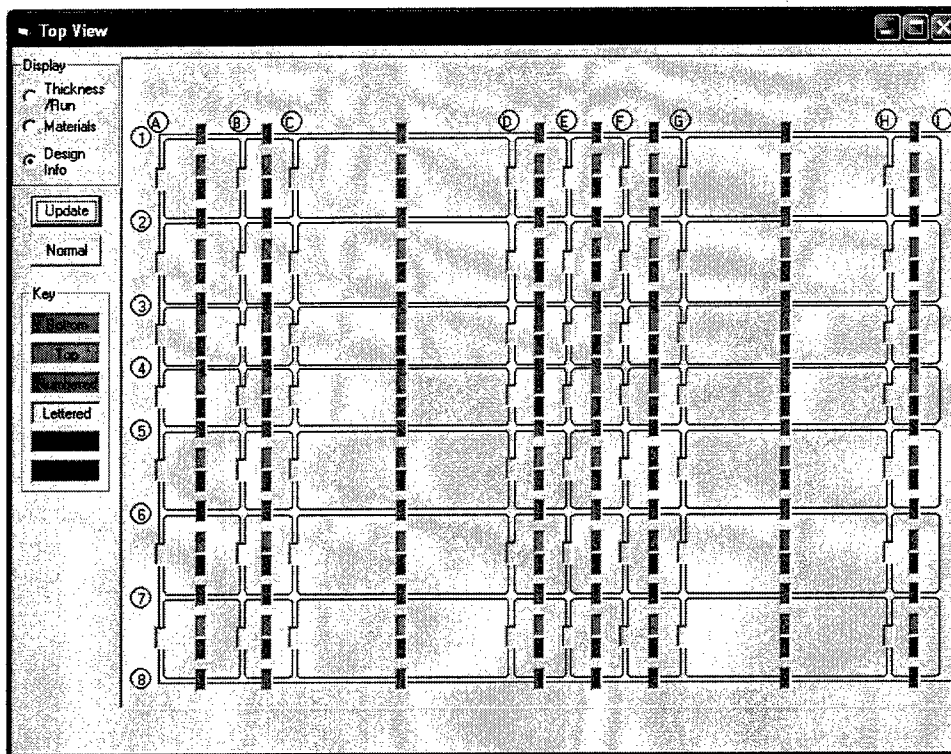

Figure 5.23. Text boxes reduced to “buttons” in Top View

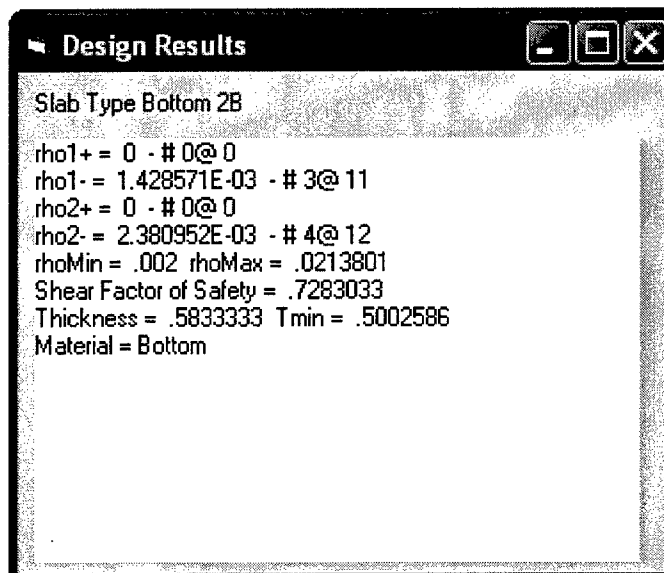

Figure 5.24. Design information

## 5.5 Generate Elements

The finite element model is generated by selecting the **Preprocess | Generate Elements** menu item. The program will switch to Phase 1 to view the results. The default plot option is to show only shell elements. The Plot Controls form can be used to select other options.

## 6 Analyze

After the finite elements are generated, additional model parameters must be defined before initiating the analysis. These inputs are controlled by the Analyze option, shown in Figure 6.1.

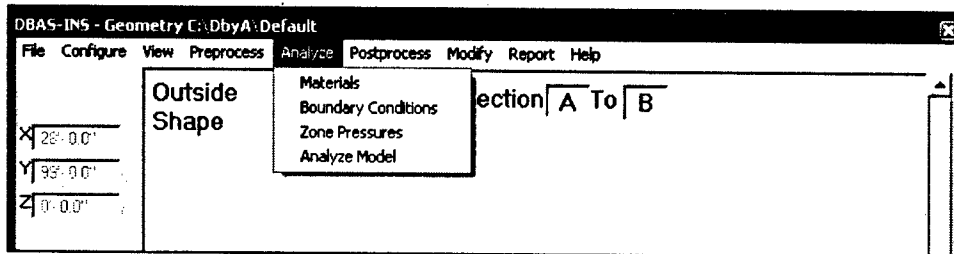

Figure 6.1. Analyze option

### 6.1 Materials

Material properties are defined by opening the Materials form under the Analyze menu item. Six distinct properties can be defined for various regions/uses in the model. These properties are automatically assigned to the appropriate elements. The six Material Names are Bottom, Top, Exterior, Interior, Bracing, and Tremie, as shown in Figure 6.2. Default values can be selected from the Material Catalog section: Normal-Weight (NW) Concrete, Lightweight (LW) Concrete, and Steel. All materials are linear elastic.

Diaphragm panels are classified as Exterior or Interior depending on their location in the structure. Exterior elements are normal-weight concrete by default because they will be exposed to flowing water. The default material for the Interior panels is lightweight concrete. Bottom elements are lightweight by default, and Top elements are normal weight. The default material for Bracing elements is steel. Figure 6.3 shows the default properties for normal-weight concrete.

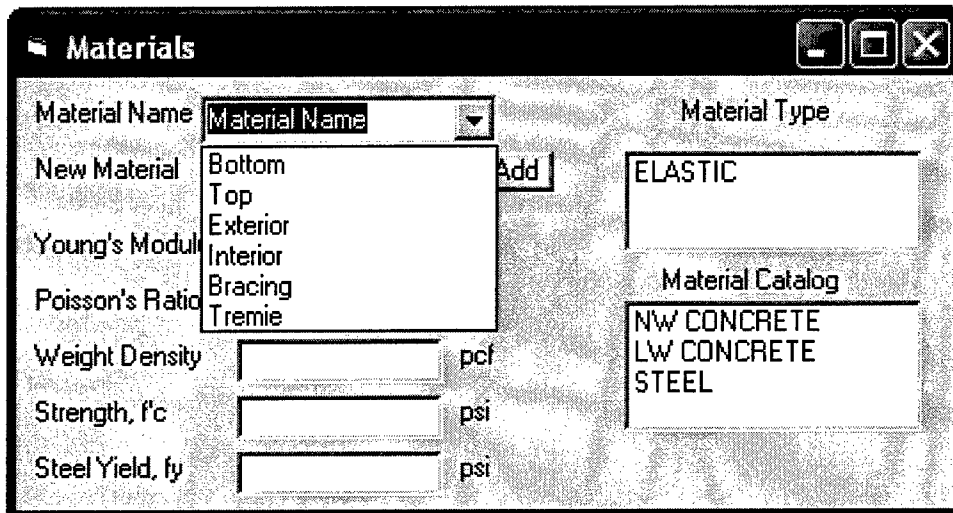

Figure 6.2. Materials form options

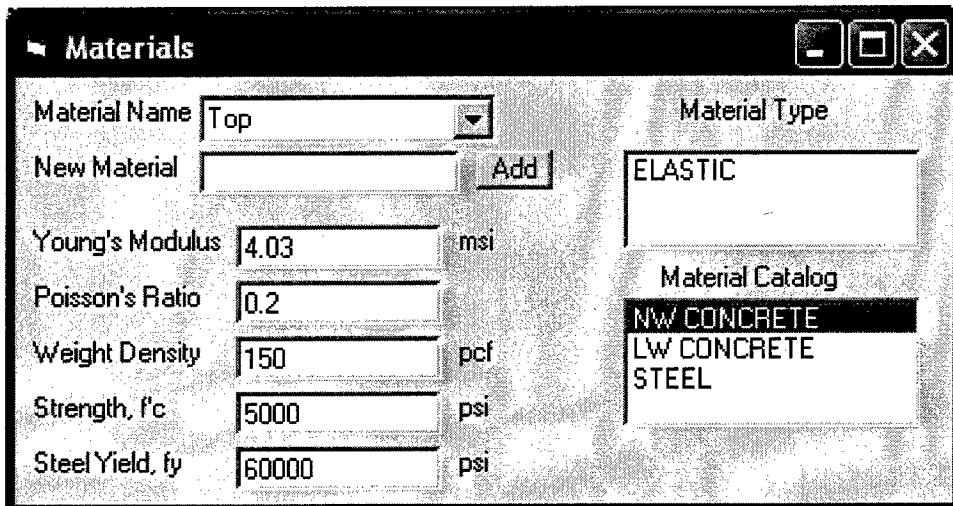

Figure 6.3. Material definition

The designer can add additional material names and properties and assign them to individual slabs in the Top View (Figure 5.22). The new material name is entered on the form, and the Add command button is clicked to add the name to the list (Figure 6.4). The user then selects the new material name in the Material Name box and defines the properties.

**Materials**

Material Name: Polymer

New Material: Polymer **Add**

Material Type: ELASTIC

Young's Modulus: 3 msi

Poisson's Ratio: 0.25

Weight Density: 140 pcf

Strength, f'c: 8000 psi

Steel Yield, fy: 60000 psi

Material Catalog:

- NW CONCRETE
- LW CONCRETE
- STEEL

Figure 6.4. Add a new material

## 6.2 Boundary Conditions

The user can set load factors for the design and select from four boundary conditions: Continuous Elastic Foundation, Floating, Set-Down Shafts, and Drilled Piers. These are selected in the Boundary Conditions form, shown in Figure 6.5.

The Continuous Elastic Foundation (CEF) is used when the segment is resting on the ground during initial construction and when the segment is grouted after set-down. The foundation stiffness in the vertical (Y) direction is input in kips per square foot. Three corners are fixed in the X and/or Z directions to provide minimal lateral constraint.

**Boundary Conditions**

Select one or more:

- Continuous Elastic Foundation
- Floating
- Set Down Shafts
- Drilled Piers

Define SDS

Define DPS

Foundation Stiffness: 100 ksf

Body Force

Float Depth: 0.0

Dead Load Factor: 1.4

Live Load Factor: 1.7

Figure 6.5. Boundary Conditions form

When the Floating (FLT) condition is selected, the draft required to support the segment is calculated and the corresponding pressure is applied to the bottom

and outsides of the segment. In addition to the minimal lateral constraint applied in the CEF case, the four corners are supported in the vertical direction by fixed springs. If the segment is balanced, the force in these springs should be negligible. The float depth required to provide the needed buoyancy is displayed on the Boundary Conditions form after calculation.

Set Down Shafts (SDS) can be placed under specified shells by checking that box and clicking the Define SDS button to activate the **Set Down Shaft Locations** form. The lower section number and letter that surround the cell define the location. The structure for Figure 6.6 has eight section numbers and five section letters. The bottoms of the cells in the four corners are supported on shafts. All shell nodes on the bottom of those cells are fixed in the X, Y, and Z directions. In the figure, the user is entering an X in box (7,D), which places a set-down shaft under the cell bounded by section lines 7, D, 8, and E.

	A	B	C	D
1	X			X
2				
3				
4				
5				
6				
7	X			X

Figure 6.6. Set Down Shaft locations

Drilled Piers (DPS) provide lateral support to the segment under service conditions. Holes are cast at the bottom of cells that must align with drilled piers. These are grouted after placement. When the DPS option is selected, the user inputs the spring stiffness of the pier in the appropriate box of the Drilled Pier Stiffness form (Figure 6.7), which appears when the Define DPS button is selected on the Boundary Conditions form. This total stiffness is distributed among appropriate nodes in both the X and Z directions. The stiffness value input in box 6B indicates that a drilled pier is located under the cell surrounded by section lines 6, B, 7, and C.

**Drilled Pier Stiffness (lb/in)**

	A	B	C	D
1	0	0	0	0
2	0	956000	0	0
3	0	0	0	0
4	0	0	0	0
5	0	0	0	0
6	0	956000	0	0
7	0	0	0	0

OK

Cancel

Figure 6.7. Drilled Pier Stiffness form

### 6.3 Zone Pressures

Significant load cases occur during construction as cells are filled to various levels with water or tremie concrete. These impose a pressure load on the bottom of the cells and on the surrounding diaphragms. Up to 10 load cases can be defined. These results are superimposed on other loads imposed by boundary conditions. The draft depth is adjusted to account for the additional weight when the Floating condition is selected.

Fluid levels are specified in the **Fluid Depths** form that is accessed by selecting the Zone Pressures option (Figure 6.8). The No (Internal) Pressure case is Load Case 0 and should have zero depth in each cell. Clicking the OK or Accept buttons stores the designated depths in the selected Load Case number. All depths should be input relative to the Y=0 coordinate which is the bottom of the segment. A positive depth value indicates that the fluid is water with a density of 62.4 pounds per cubic foot. A negative depth value indicates that the fluid is tremie concrete. The density of the tremie concrete is input in the Material form discussed in Section 6.1. Figure 6.8 shows that the user input 12 in box 2C. The depth of water in the cell surrounded by section lines 2, C, 3, and D is 12 ft above the bottom of the structure. If the bottom slab is 1 ft thick, the maximum water pressure inside the cell would be for a depth of 11 ft.

**Fluid Depths (ft.)**

	A	B	C	D
1	5	0	0	0
2	0	0	12	0
3	0	0	0	0
4	0	10	0	0
5	0	0	0	0
6	0	0	0	0
7	0	0	0	0

OK  
Cancel  
Accept

**Load Case**

LC3  
LC4  
LC5  
LC6

Figure 6.8. Input Fluid Depths in cells

Nodal forces can also be specified for each load case. Clicking the Node Force button on the “Fluid Depths (ft.)” form activates the Nodal Force form (Figure 6.9). Clicking Impose applies the specified load values to the selected node in the selected Load Case. The user will need to turn on Node Numbers in the Plot Control Form (Figure 4.8) and zoom in to the region to determine the correct node number.

**Nodal Force**

Node Number

X Force

Y Force

Z Force

Impose

Figure 6.9. Nodal Force form

## 6.4 Analyze Model

The Analyze Model selection runs a full finite element analysis of the structure using the specified boundary conditions. The nodal displacements are calculated for the baseline (No Internal Pressure) load case that consists of body forces due to the weight of the structure and external water pressure in the floating condition. The additional loads due to internal pressures are run as separate load cases. These results are superimposed during Postprocessing.

# 7 Postprocess

Results from the finite element analysis can be displayed as deformed shape plots; shear, moment, and thrust contour plots; stress contour plots; and shear, moment, and thrust diagrams. The concrete slabs can then be designed based on the structural requirements. These options are available under the Postprocess menu item (Figure 7.1).

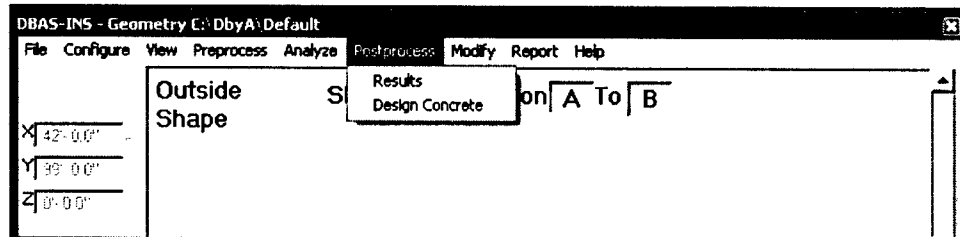

Figure 7.1. Postprocess option

## 7.1 Deformed Shape

The deformed shapes are controlled by the setting for the Deformation Multiplier in the Results form (Figure 7.2) that is displayed when the analysis is complete or when Postprocess | Results is selected. The load case for the results can be selected in the Zone Pressures form shown in Figure 6.8. The original shape can be turned on and off in the Plot Control form (Figure 4.6). Figure 7.3 is the deformed shape plot of the shell elements of a spillway model in the floating condition.

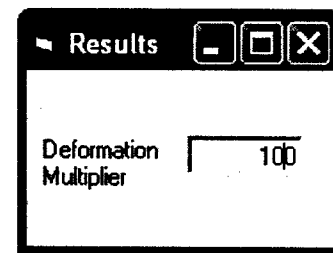

Figure 7.2. Deformation multiplier

## 7.2 Shear, Moment, and Thrust Contours

Shear, moment, and thrust results on shell elements are plotted by creating a rendering under the **View | Render** option (Figure 7.4). The user selects one of six components to plot. The solid option is discussed in Section 7.3. The **Extents** on the **Plot Control** form (Figure 7.5) may be changed to allow a clear view of any shells in the model. These results are presented in units per foot. Shear and thrust are pounds per foot, and moment is in foot-pounds per foot. Figure 7.6 shows moments on the bottom slab of a floating model. These values are used for the design calculations.

Shear, moment, and thrust are reported in local directions. These are consistent for all slabs of a given type. The definitions are

- Bottom – 1 is X direction, 2 is Z direction.
- Top – 1 is X direction, 2 is Z direction.
- Numbered – 1 is X direction (horizontal), 2 is Y direction (vertical).
- Lettered – 1 is Z direction (horizontal), 2 is Y direction (vertical).

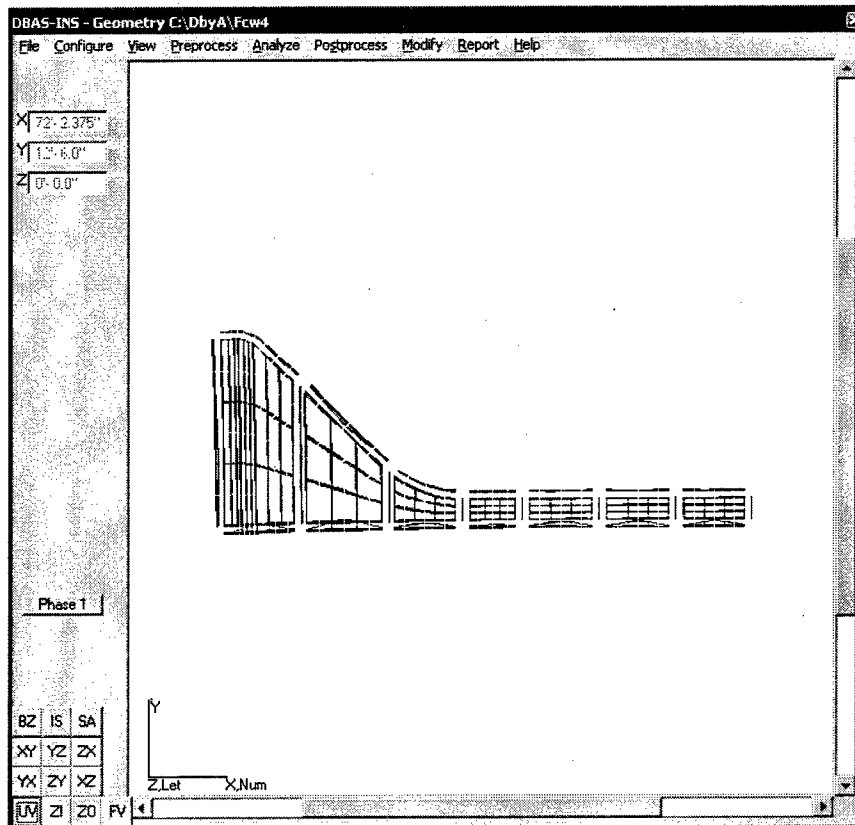

Figure 7.3. Deformed shape plot

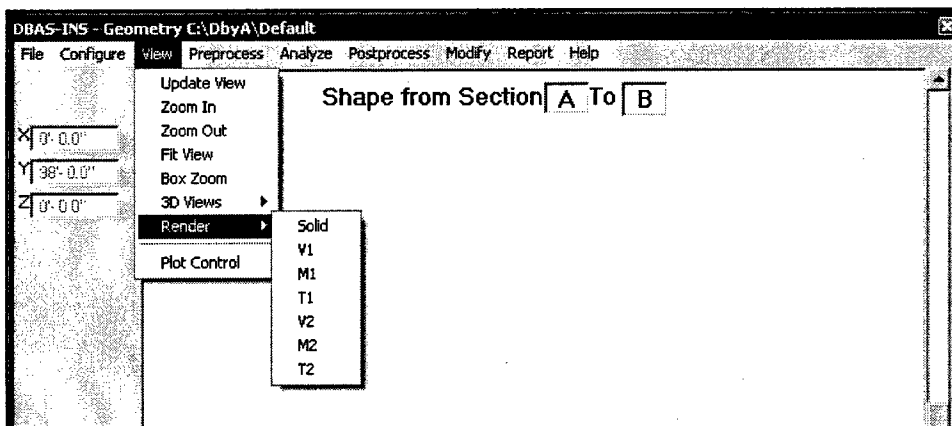

Figure 7.4. View | Render option

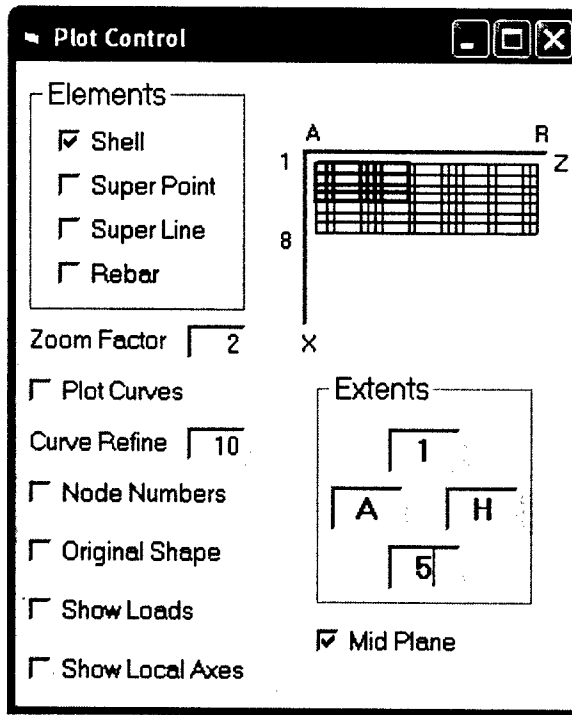

Figure 7.5. Set the Extents of the model to be plotted in the Plot Control form

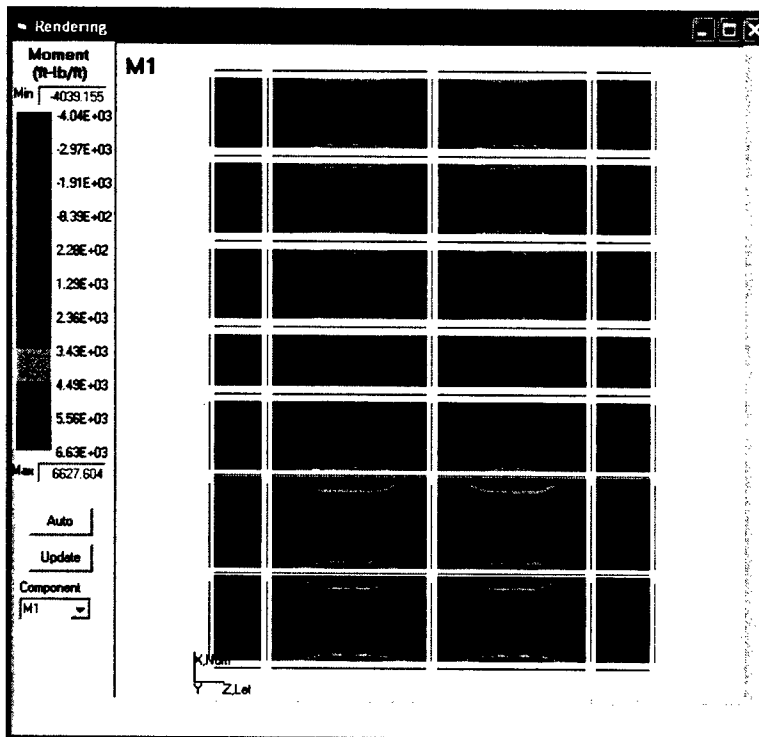

Figure 7.6. Moment contours

Figure 7.7 shows the naming convention for the tractions on a shell element.

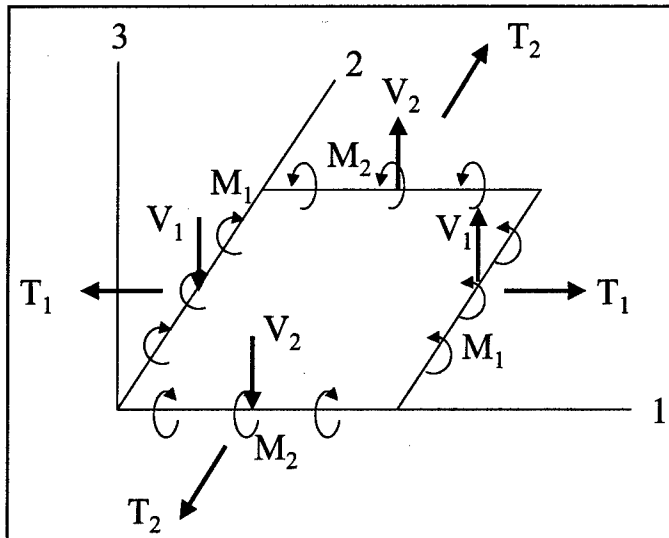

Figure 7.7. Shear, moment, and thrust naming convention

The view plotted on the Rendering is the same as the current view in the main DBAS-INS form. Once the Rendering is created, selecting the desired result in the Component box in the lower left-hand corner of the Rendering form can plot other response components. The contour intervals can be changed by entering the desired **Minimum** and **Maximum** in the text boxes at the top and bottom of the contour bars. Click **Update** to replot the response using the new intervals. The Automatic intervals can be reset by clicking **Auto** and then **Update**. Figure 7.8 shows contours for an out-of-plane shear component.

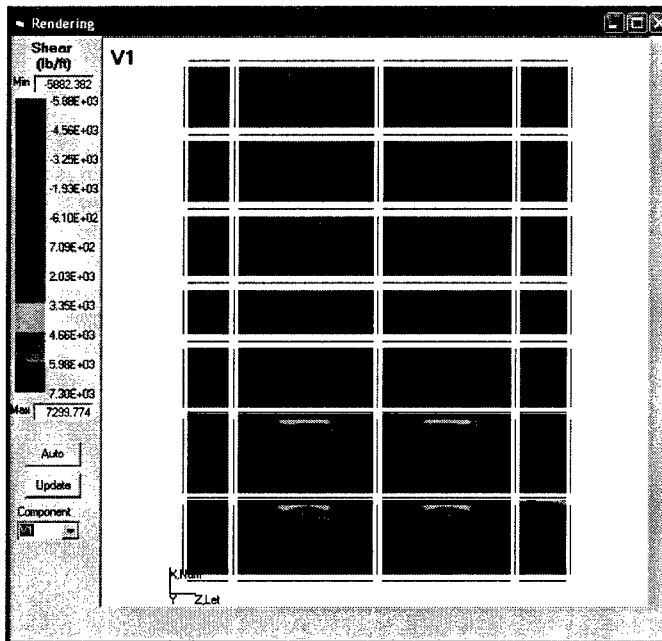

Figure 7.8. Thrust results

## 7.3 Stress Contours

### 7.3.1 Surface stresses

Selecting **Solid** under the **View | Render** option (Figure 7.4) plots stress values on the exposed faces of superelements and shells. The units on these plots are converted to pounds per square inch. Any of the six stress components can be plotted by changing the selection in the **Component** box. Contour intervals can also be changed, as described in Section 7.2. Figure 7.9 shows the X stress component on a small model. Stresses are plotted at the surface of both shell and super elements. These results for stresses in the Z direction are shown in Figure 7.10.

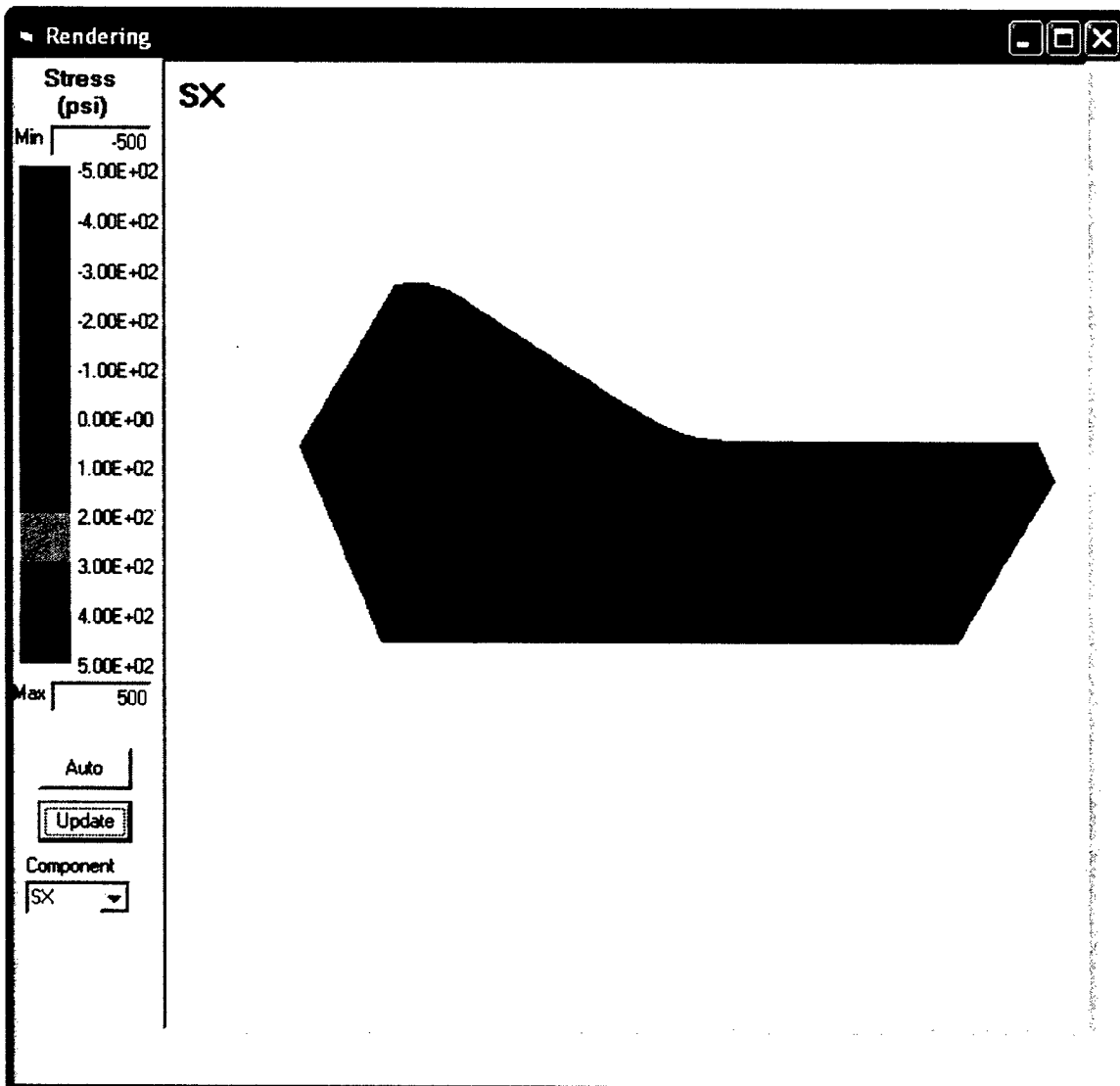

Figure 7.9. Stress contours on superelements

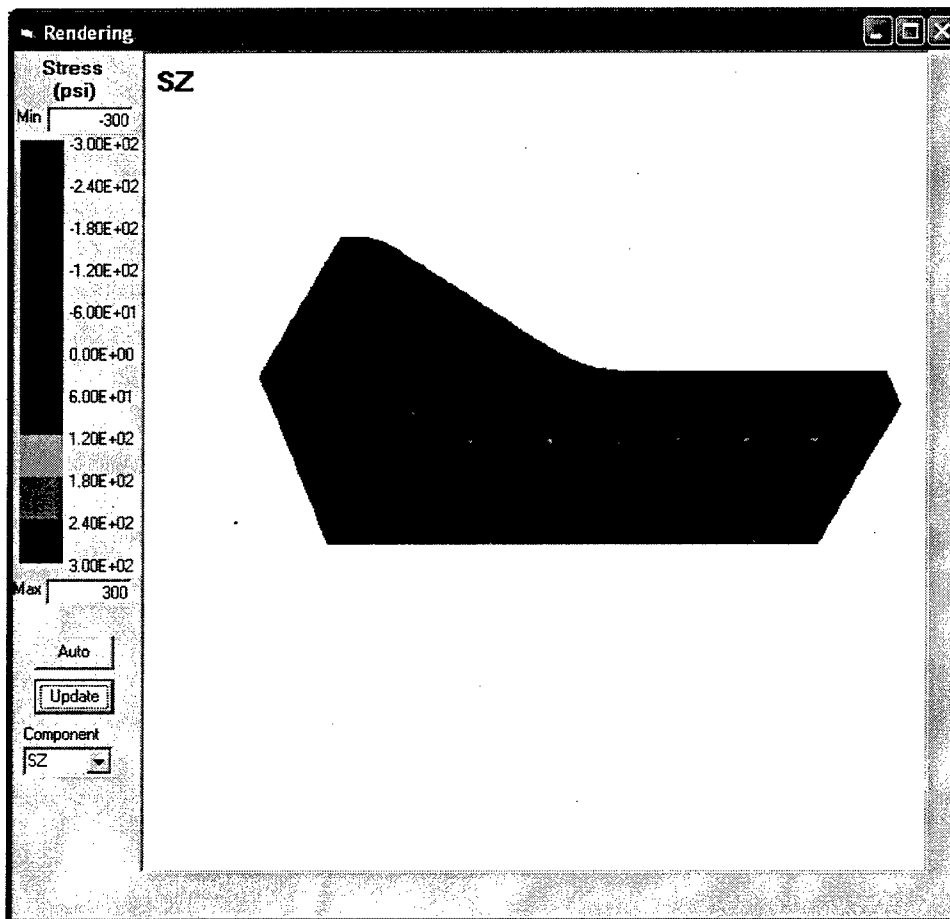

Figure 7.10. Plot of Z-direction stresses

### 7.3.2 Cross-section stresses

A contour plot is assembled from facets constructed from the shell and super elements that are cut by the cross section. These are typically quadrilaterals (triangles are present in prism elements) with the stress value known at each corner. A value for the stress is calculated at the middle of the quadrilateral by averaging the nodal values, and the element is broken into four triangles. The triangles are plotted with colored bands representing the stress values.

Shear, moment, and thrust diagrams can be extracted from cross-sectional stress contour plots created in Phase 2. Left-clicking the **Phase 1** button on the main DBAS-INS form (see Figure 7.3) changes the current plot to cross-sectional stress contours. The plane in the plot is controlled by the current view in the DBAS-INS Form and Extents selected in the Plot Control form (Figure 7.11). The stress contours on a **Mid Plane** cross section are shown in Figure 7.12. These are stresses midway between two diaphragm walls. When the Z direction is normal to the plot (XY or YX), the plane is in the North-South direction. It is plotted for the minimum section letter selected in Extents. When **Mid Plane** is checked, the plot is to the right of the minimum section letter, as indicated by the red line on the Extents sketch.

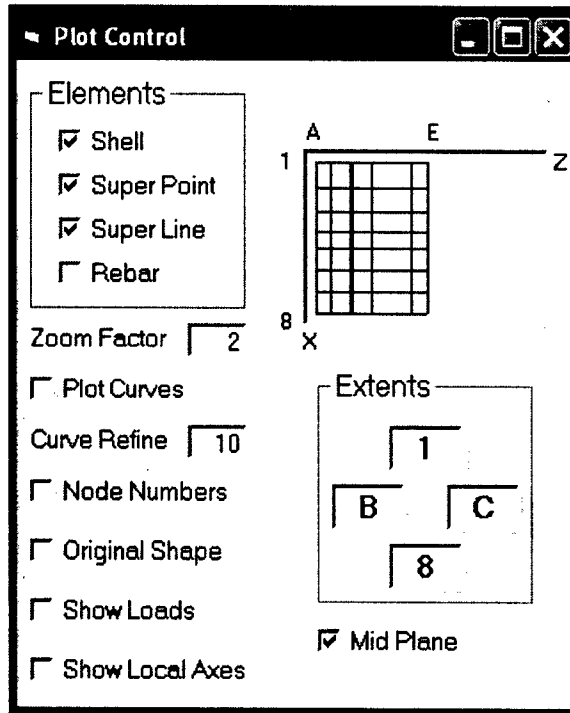

Figure 7.11. The minimum Extent designates which cross section to plot

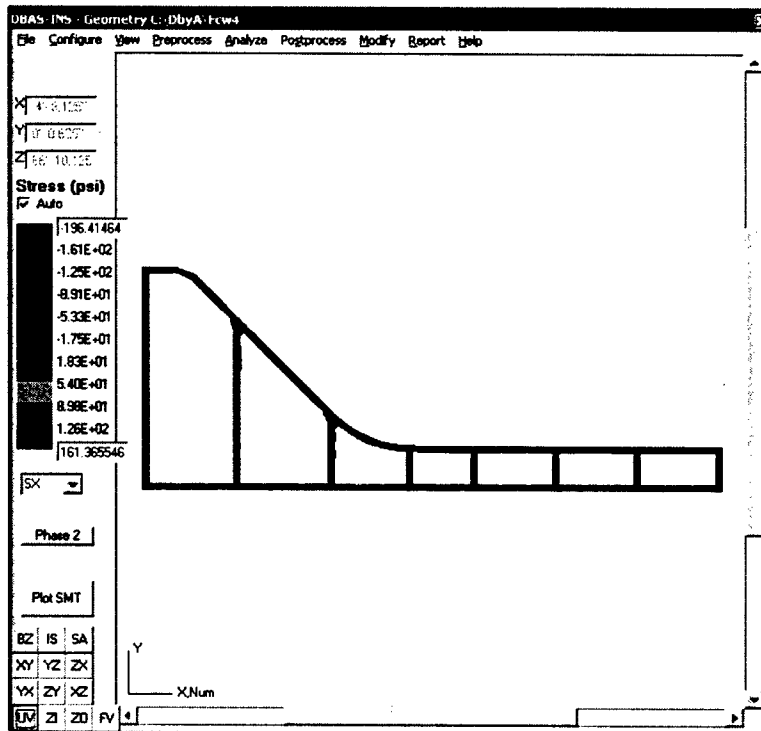

Figure 7.12. The X-stresses through the midplane of a model

When the X direction is normal to the plot (YZ or ZY), the plane is in the East-West direction. It is plotted for the minimum section number selected in Extents (Figure 7.13).

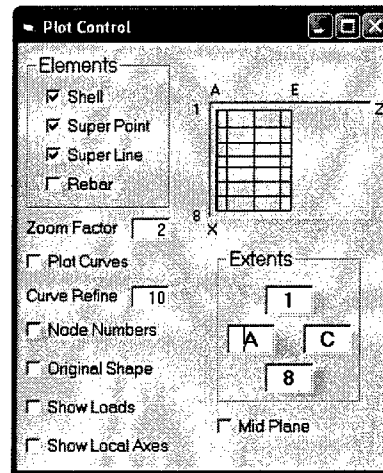

Figure 7.13. Plot Control indicating location of the plot in red

Figure 7.14 shows a plot of vertical stresses through section 1. This cross section cuts through the midplane of the shell element.

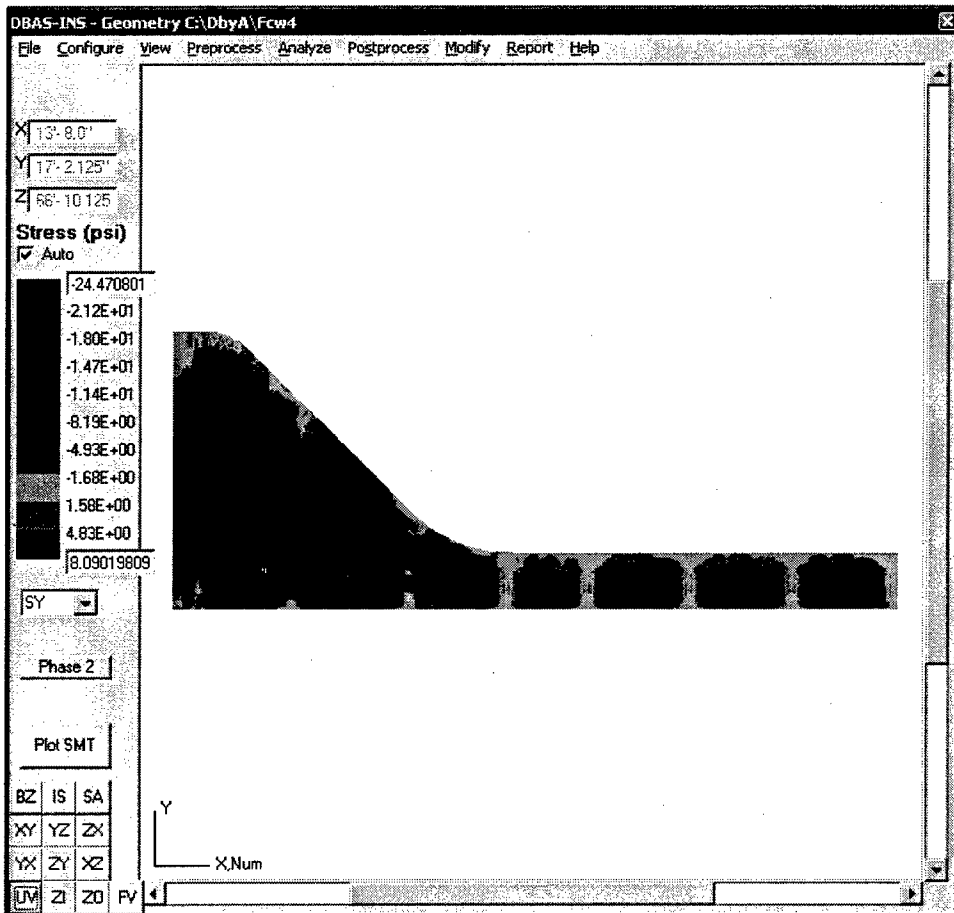

Figure 7.14. Change to a plot of Y stresses on an XY plane

## 7.4 Shear, Moment, and Thrust Diagrams

Shear, moment, and thrust diagrams can be plotted for selected regions. Clicking Plot SMT opens the Shear Moment Thrust form, shown in Figure 7.15. A Shear, Moment, or Thrust diagram can be plotted by clicking the appropriate button (**Shear**, **Moment**, or **Thrust**), or all results for the full model can be plotted by clicking **All Three**. The results for the full model are difficult to interpret and, generally, not helpful in design. The default option is to consider stresses across the entire cross section. However, smaller regions of the plot can also be identified in the program, to look at the behavior in local areas.

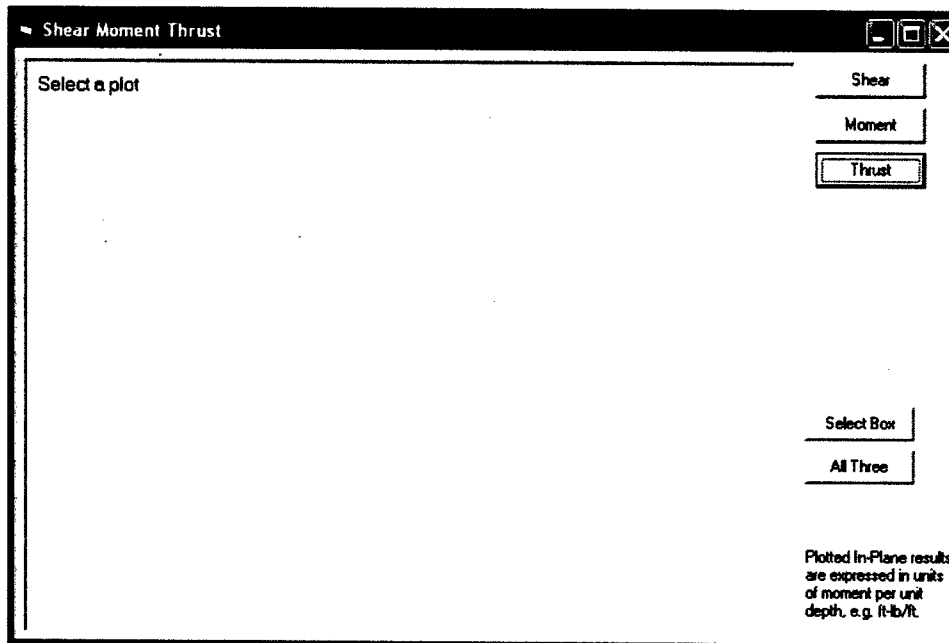

Figure 7.15. Shear Moment Thrust form

The axis of the plot is defined by the current view selected in the program. The facet information generated for the contour plot (discussed in Section 5.2) is scanned to calculate the tractions at 100 X-coordinate values along the horizontal axis of the selected region. All facets that are intersected by the vertical line through a given X-coordinate are identified, and the stresses at the two points of intersection (bottom and top) are interpolated from the nodal values for that facet. The six stress components are extracted for various plots. The stress distribution through the designated cross section is then constructed from these data and evaluated to determine shear, moment, and thrust values.

A region of the model can be selected by clicking **Select Box** and outlining the area on the DBAS-INS plot. Figure 7.16 is the plot of cross-sectional stresses.

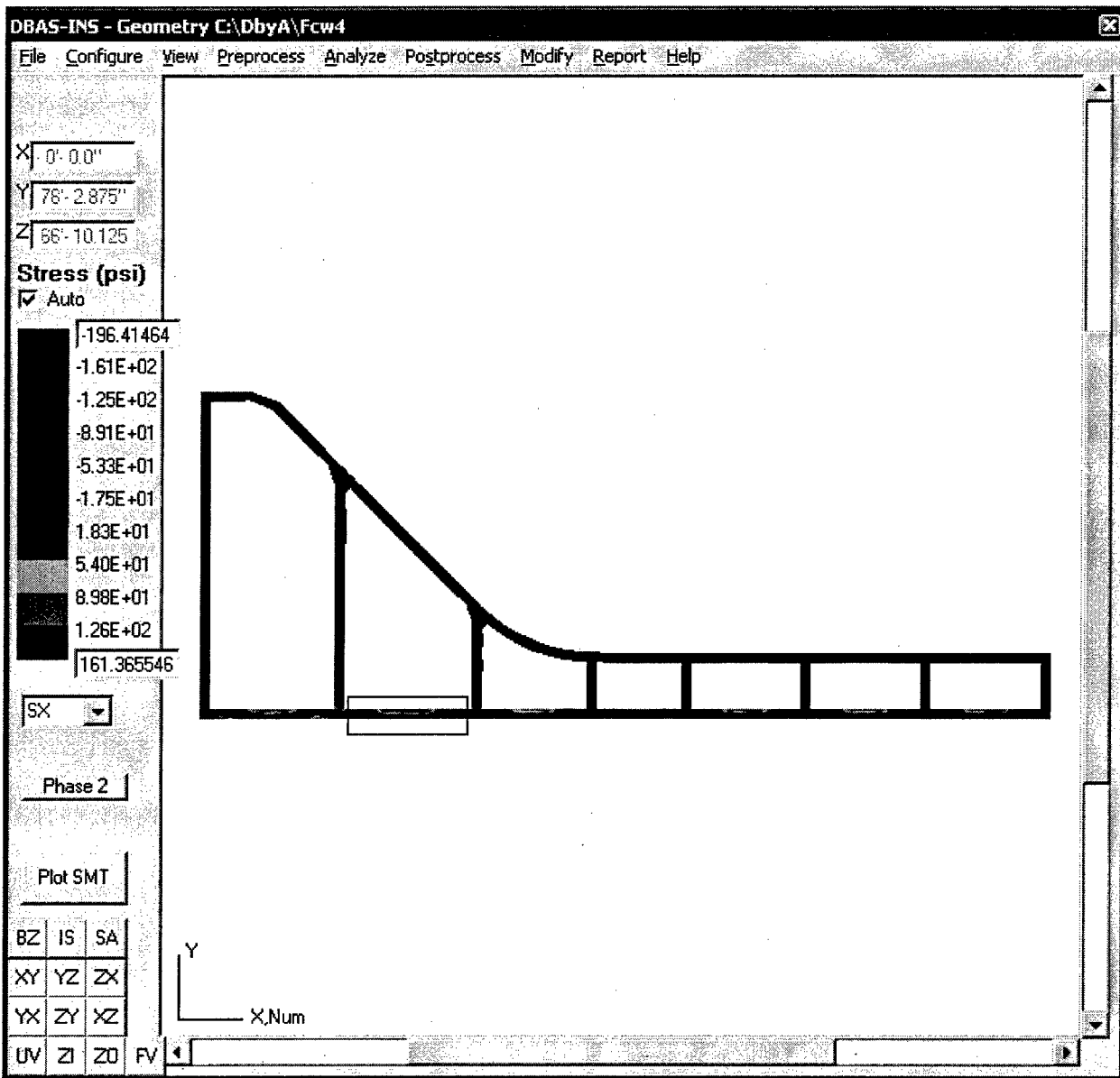

Figure 7.16. Select a box for SMT plotting

Shear, moment, and thrust diagrams through the middle of the bottom slab are plotted in Figure 7.17.

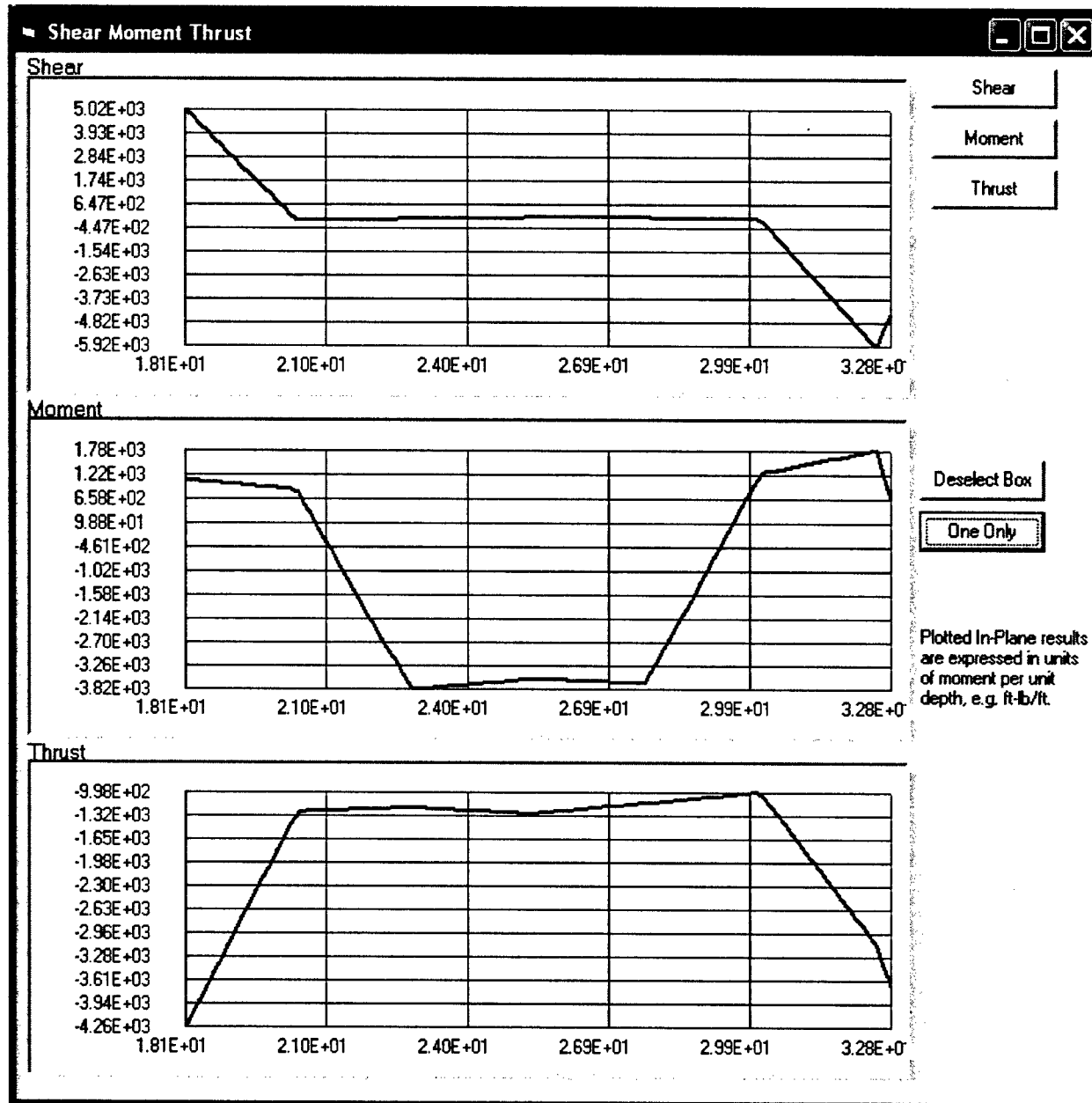

Figure 7.17. Shear, moment, and thrust on a bottom slab

## 7.5 Design Concrete

The program will check to see how well the design meets ACI requirements and will also designate areas that may be overdesigned. These checks are performed when **Postprocess | Design Concrete** is selected. Results from the design calculations can be viewed by selecting **Design Info** in the Top View (**Preprocess | Top View** to display) and clicking the text box for the slab. Figure 7.18 is the top view for a typical design with **Shrink** on (click the **Normal** button to return to full-size text boxes), and Figure 7.19 shows the design results.

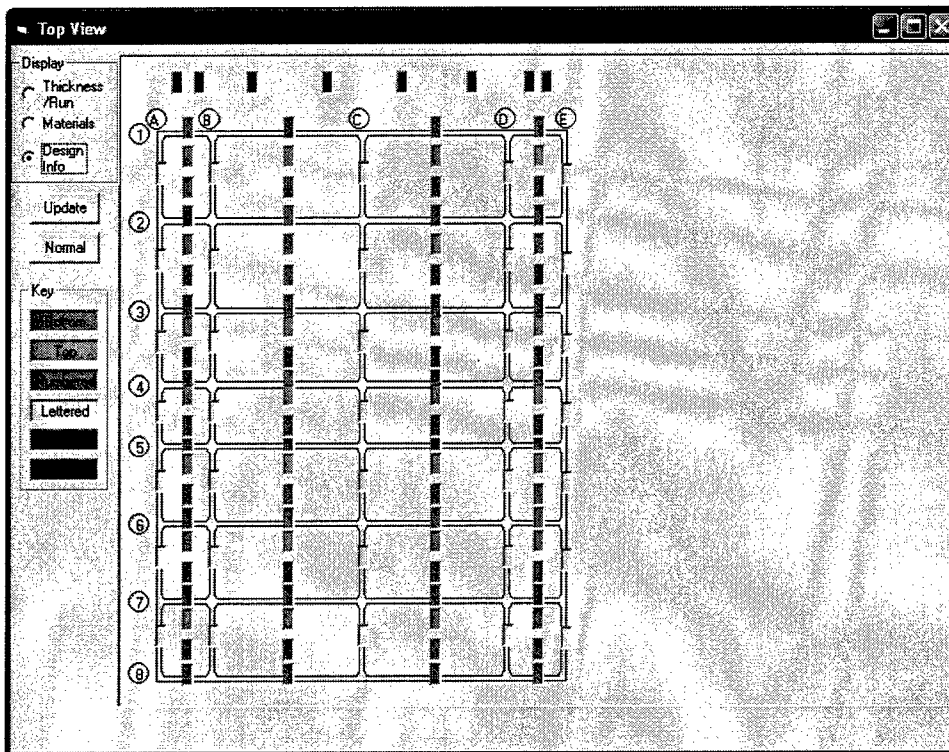

Figure 7.18. Top View to display design information

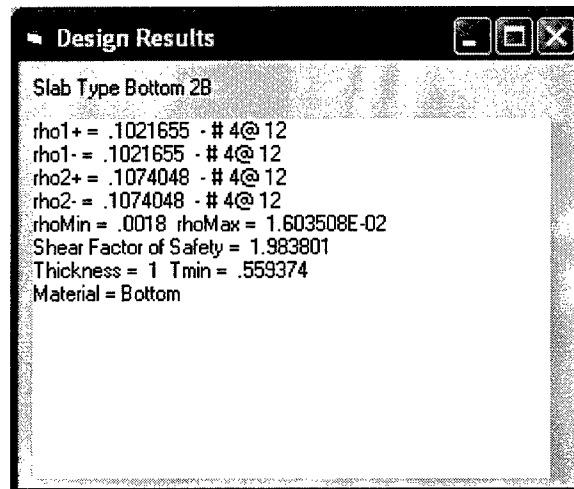

Figure 7.19. Design information

The design information includes the steel ratios and layout for the four layers of rebar in the slab, as described in Section 5.4.

## 8 Modify

---

The user can select Redesign under the Modify menu item (Figure 8.1) to automatically adjust slab thicknesses to improve the design.

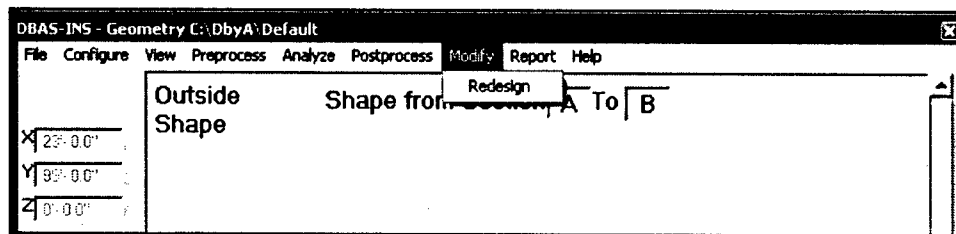

Figure 8.1. Modify option

One goal in the design is to produce the lightest structure that meets all requirements. A second goal is to produce a constructible design that allows for reuse of formwork and reinforcing schedules that are easy to fabricate. The automatic redesign procedures developed for DBA are based on these two goals.

Designs are screened to identify slabs that may be oversized. These are slabs with a high factor of safety for shear and a low reinforcement ratio. The thickness of these slabs is reduced in 1-in. increments and redesigned based on the shear, moment, and thrust values from the initial analysis. Although this is not exact, small changes in thickness will have little effect on these results. If the design for this thinner section is acceptable, the slab thickness is changed in the design. The thickness is further reduced, and the redesign calculations are repeated until an unacceptable design is produced.

Similarly, automatic redesign procedures increase the thickness of slabs that are underdesigned. The shear factor of safety is less than 1 in these slabs, the steel reinforcement ratio is greater than the allowable, the thickness is insufficient to construct the slab given the required reinforcement, or the thickness is less than the minimum allowed for serviceability by ACI 318.

# 9 Report

---

The **Report** menu item allows the user to generate either a **Design Summary** report that lists the requirements for reinforcing steel in each slab in the structure or a **Neutral Geometry File** to export drawing information from the model. These options are shown in Figure 9.1.

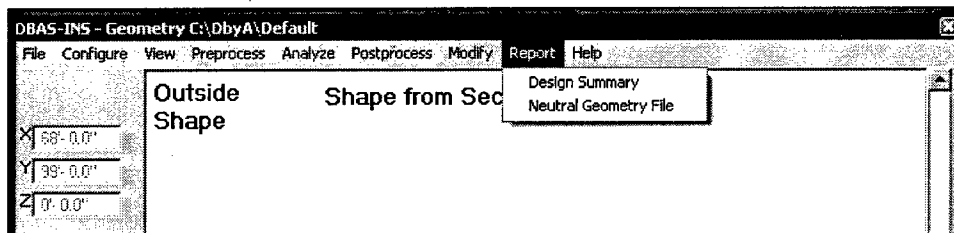

Figure 9.1. Report option

## 9.1 Design Summary

The Design Summary is stored in a text file, *modelname.rpt*. The file lists the thickness and reinforcement requirements for each slab in the structure.

## 9.2 Neutral Geometry File

The format for the Neutral Geometry file is described in Appendix C. The file, *modelname.ngf*, is a text file containing three sets of data—Spillway Outlines, Shell Elements, and Super Elements. A simple macro can be created for a computer-aided drafting (CAD) program to read the data and create lines in a CAD file.

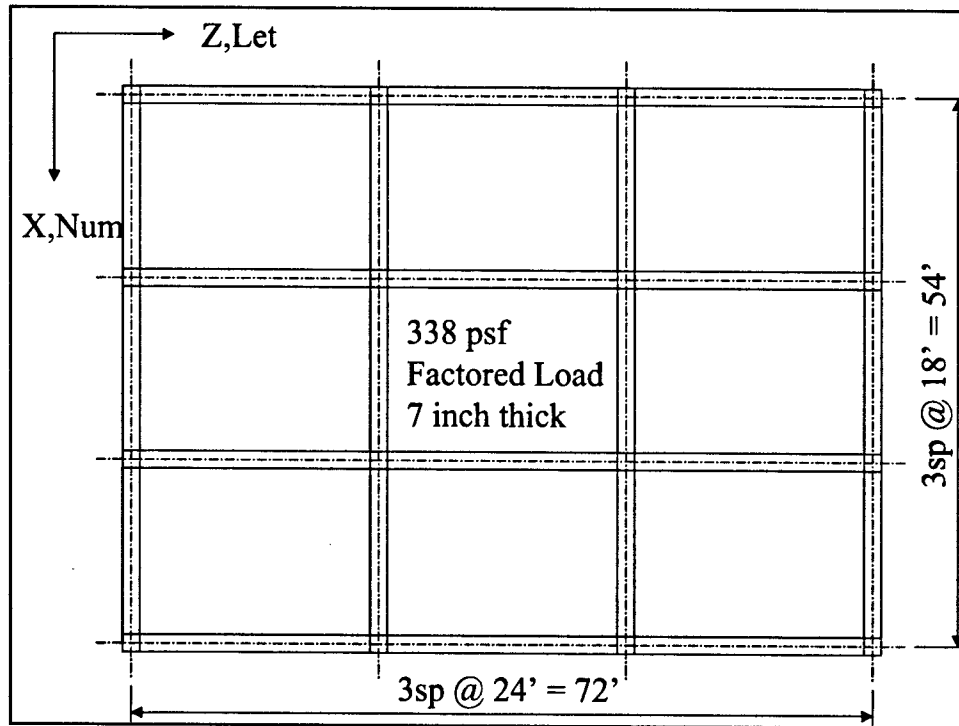

a. Plan view

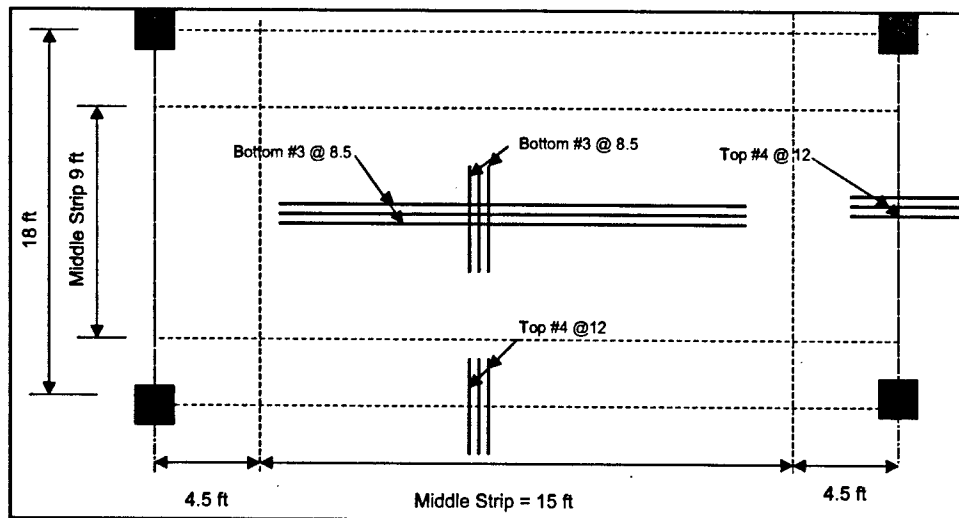

b. Textbook solution

Figure A1. Floor slab design

The structure is modeled in the Design by Analysis System–Innovative Navigation Structures (DBAS–INS) as a rectangular floating segment with three bays in each direction. The bottom of the segment simulates the floor slab. The density of the concrete in the structure was adjusted so that the net pressure on the bottom of the segment was equal to the factored load on the floor slab. Net pressure is the applied pressure reduced by the actual weight per square foot of the concrete slab. The factored floor load in the example was 338 psf, and the weight of this 7-in.-thick slab is 88 psf. The required draft on the floating structure to exert this pressure is  $426 \text{ psf} / 62.4 \text{ pcf} = 6.83 \text{ ft}$ . The density of all

concrete, other than that on the bottom, was set to 100.4 pcf in order to create this load condition. Results on the slab panel in the center of the structure will be evaluated since loads on that slab are most like those on a floor slab; that is, they will not be greatly affected by pressures on the side walls.

## 2 Configure

Executing the DBAS-INS program opens the form shown in Figure A2. New model creation can begin with options in the Preprocess menu item, but the user should check the options under the Configure menu item (Figure A3) first.

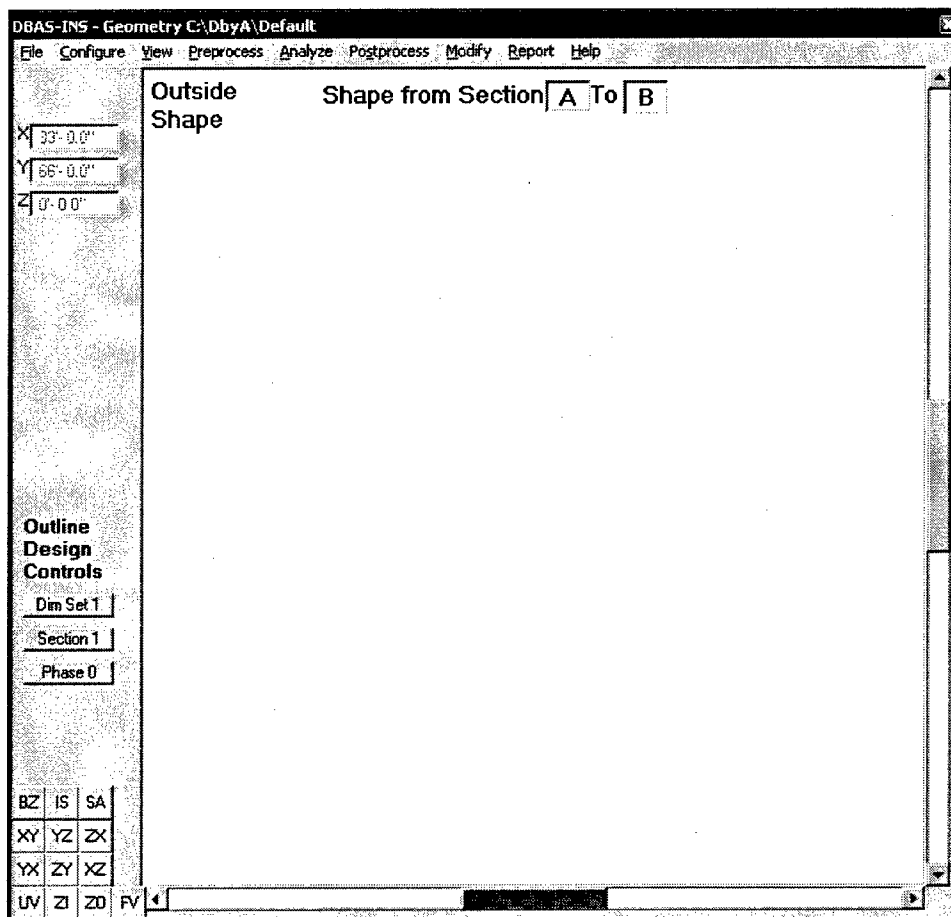

Figure A2. DBAS-INS form

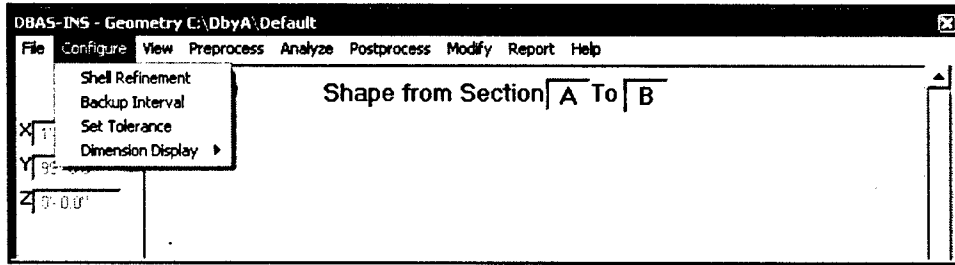

Figure A3. Configure menu item

The user should select an appropriate level of refinement for the finite element mesh. Three elements were used in each direction in the preliminary model. The value is entered in the Shell Refinement form shown in Figure A4.

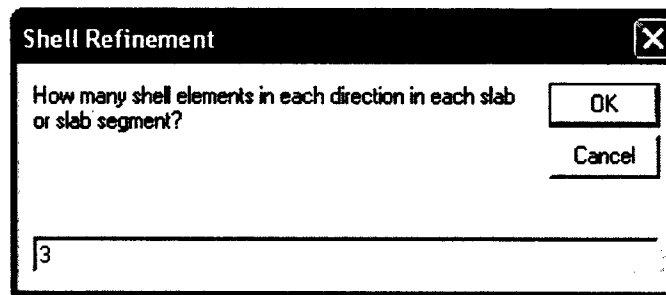

Figure A4. Shell Refinement form

The model is saved to a backup file at regular intervals. If program execution is stopped for any reason, the user can retrieve most of the work performed up to that time. The default value for the backup interval is 1 min. This can be changed in the Backup Interval form shown in Figure A5.

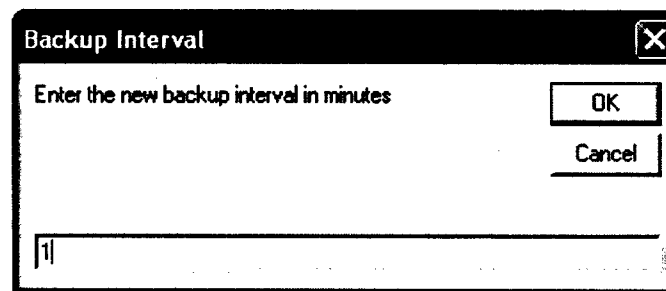

Figure A5. Backup Interval form

The tolerance value is used throughout the program to account for the effects of numerical round-off errors. Two points that are less than this value from each other are considered to be at the same point. The default value of 0.005 ft works well in most applications but can be changed in the Set Tolerance form (Figure A6).

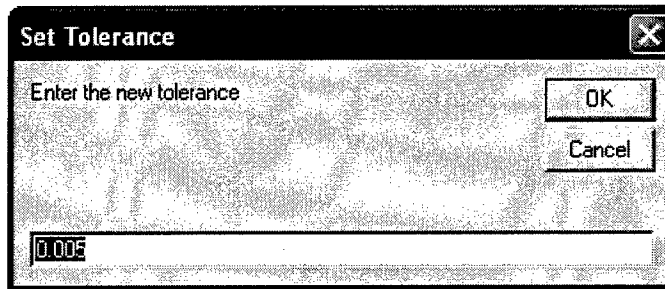

Figure A6. Set Tolerance form

### 3 Preprocess

After verifying the configuration settings, the user begins the preprocessing phase. The Preprocess menu options are shown in Figure A7. The first step is to input the locations of the diaphragm walls. The beams in the floor slab example must be modeled as walls in the DBAS-INS program. The section lines are placed at the beam center lines shown in Figure A1a.

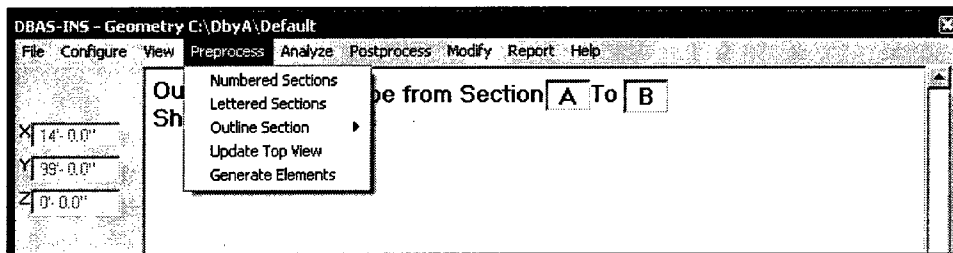

Figure A7. Preprocess menu item

#### 3.1 Numbered section lines

Clicking Numbered Sections under the Preprocess menu item prompts the user for the number of numbered (E-W) section lines. The number, 4, is entered as shown in Figure A8 for this structure.

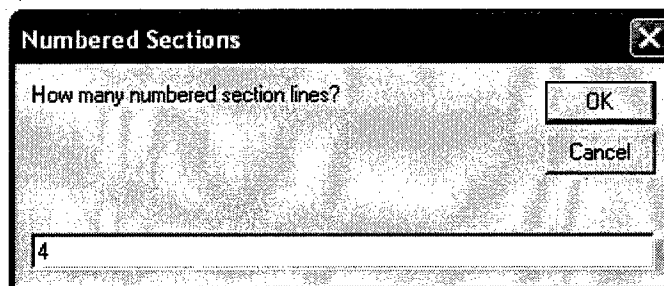
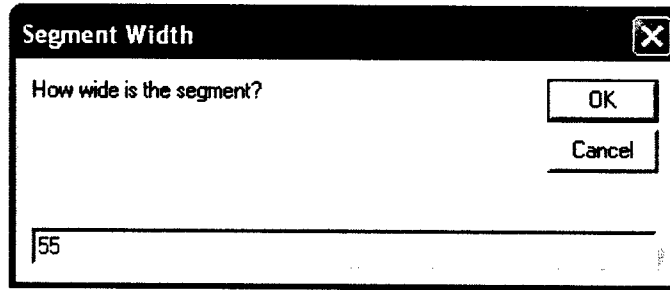

Figure A8. Enter 4 numbered section lines

The user is then prompted for the segment width. Width is defined to be the dimension in the N-S direction. The center-line spacing is 18 ft and the walls are 1 ft thick, so the total width of the segment is 55 ft as shown in Figure A9.



Segment Width

How wide is the segment?

OK

Cancel

55

Figure A9. Segment width is 55 ft

After the segment width is entered, the Numbered Section Coordinates form in Figure A10 displays default locations for the E-W diaphragm walls. The X coordinates are spaced at equal intervals. The default thickness of 1 ft will be used. The default number of shell elements in the horizontal direction is set equal to the Shell Refinement value entered in Figure A4. The default values are accepted by clicking OK.

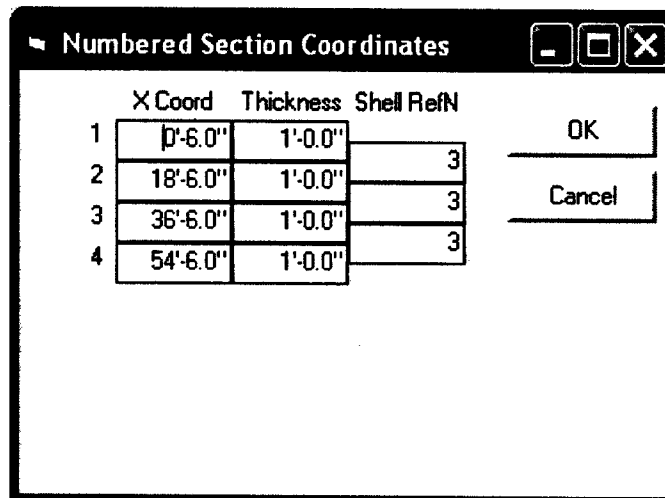

Numbered Section Coordinates

	X Coord	Thickness	Shell RefN
1	0'-6.0"	1'-0.0"	3
2	18'-6.0"	1'-0.0"	3
3	36'-6.0"	1'-0.0"	3
4	54'-6.0"	1'-0.0"	3

OK

Cancel

Figure A10. Numbered Section Coordinates form

### 3.2 Lettered section lines

After defining the locations of diaphragms in the E-W direction, similar steps are performed to lay out the N-S diaphragm walls. Selecting Lettered Sections in the Preprocess menu item (Figure A7) prompts the user to enter the number of lettered sections in the Lettered Sections form, shown in Figure A11. Again, since there are three panels in each direction, four section lines are required.

Lettered Sections

How many lettered section lines?

4

OK

Cancel

Figure A11. Lettered Sections form

The panel dimension is 24 ft in the E-W direction, so the total length of the segment is 73 ft, accounting for a 1-ft wall thickness (Figure A12).

Segment Length

How long is the segment?

73

OK

Cancel

Figure A12. Input the overall segment length

The default Z coordinates of the center lines of the N-S diaphragm walls place them at equal spaces. The form shown in Figure A13 also allows the user to designate the location and height of pier walls. This is not applicable in this example. A zero height indicates that there is not a pier wall along that section line.

Lettered Section Coordinates

	Z Coord	Thickness	Shell Ref.	Pier Height
1	0'-6.0"	1'-0.0"		0'-0.0"
2	24'-6.0"	1'-0.0"	3	0'-0.0"
3	48'-6.0"	1'-0.0"	3	0'-0.0"
4	72'-6.0"	1'-0.0"	3	0'-0.0"

OK

Cancel

Figure A13. Lettered Section Coordinates

After entering the locations of the diaphragm walls, the user may wish to look at the top view by selecting the Update Top View option from the Preprocess menu (Figure A7). The sketch shown as Figure A14 shows the

location of the numbered and lettered sections as previously defined. Additional details are added as described below.

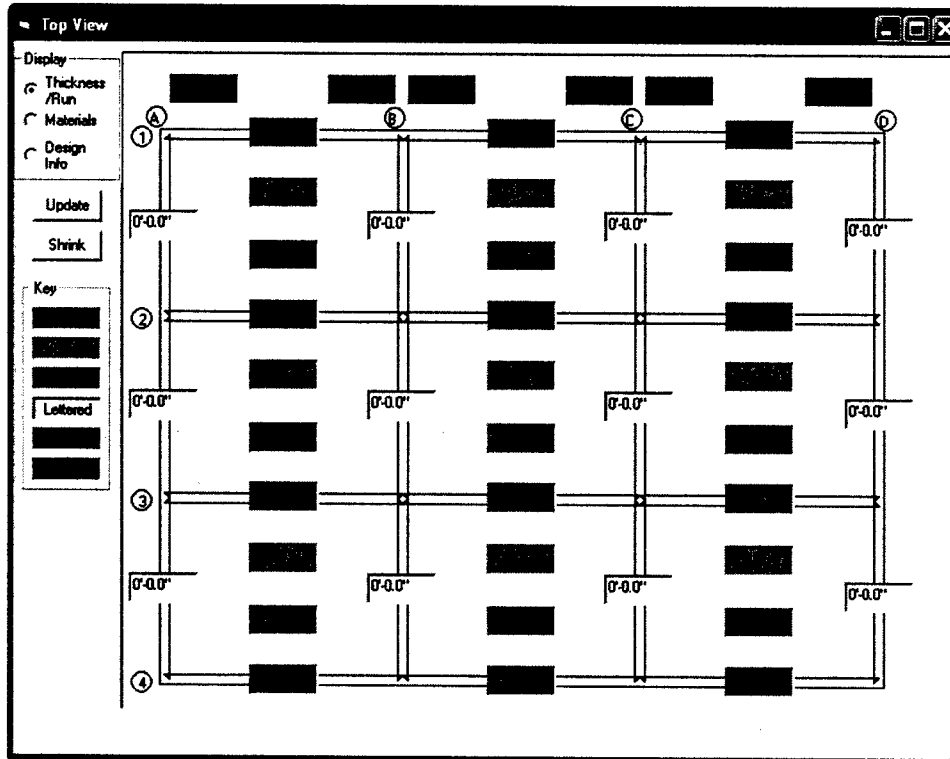

Figure A14. Preliminary plan view

### 3.3 Outline section

The next step in the preprocessing phase is to define the cross-section geometry along the N-S diaphragm walls. The user first opens a template for the spillway shape at the west side of the segment. If the segment has additional spillways with different shapes, these will be described, in order, from west to east. Available spillway shapes are listed in the Outline Section option in the Preprocess menu, as shown in Figure A15.

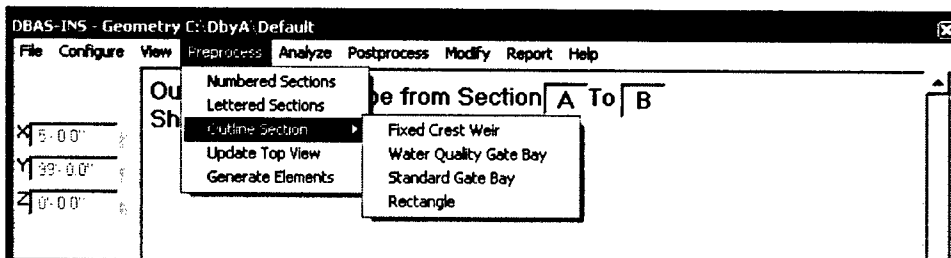

Figure A15. Select from standard spillway templates

A simple rectangle was used in this example. The initial cross-section geometry shown in Figure A16 is generated given the default height of 20 ft and the locations of the E-W diaphragm walls. The “spillway” cross section will be

constant across this model, so this shape is defined from section line A through section line D, as indicated at the top of the sketch.

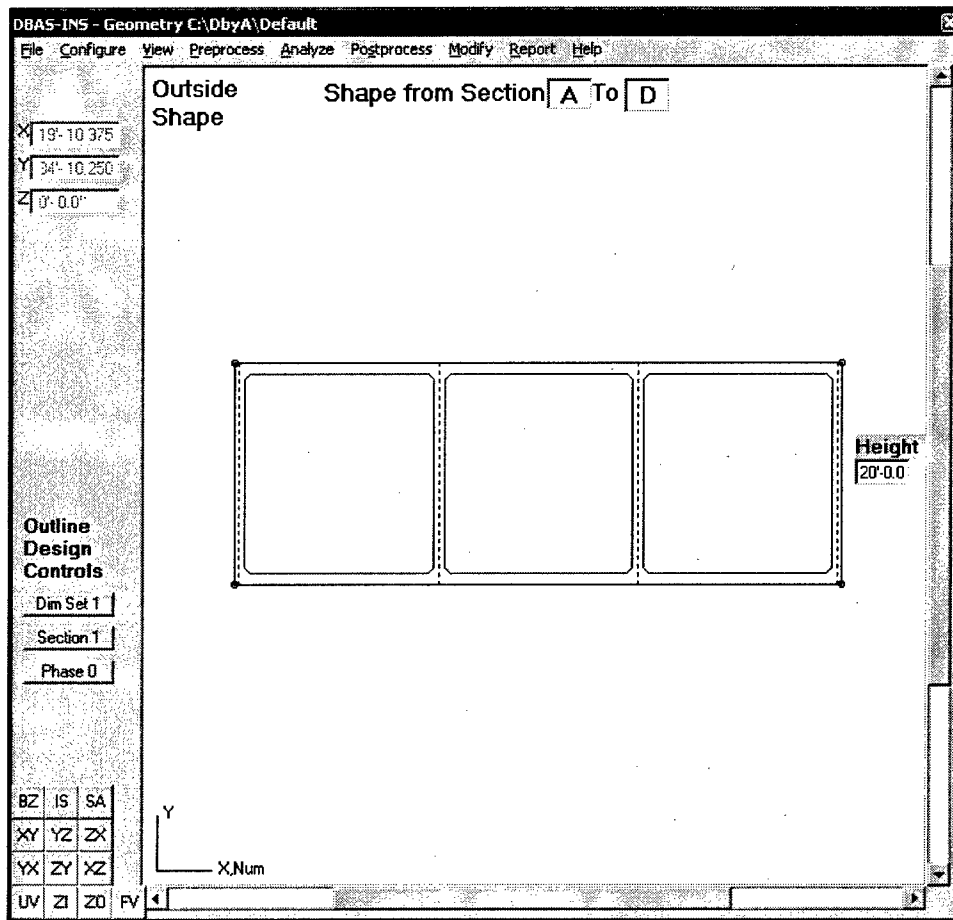

Figure A16. Default rectangular cross section

At some time early in the session, the user will want to save the model using a user-defined file name. This action is initiated by selecting Save As under the File menu item shown in Figure A17.

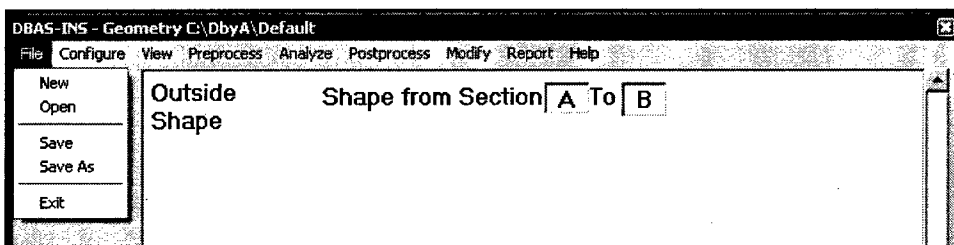

Figure A17. File menu option

The Save As form (Figure A18) appears for the user to select the location for the file and the file name. The file *Example1.dba* is created in this case, and subsequent backups will be written to *Example1.ba0* and *Example1.ba1*. After saving, the user can exit the program and restart at any time by executing the

program and selecting the Open option under the File menu item. The user is then prompted to select an existing file as shown in Figure A19.

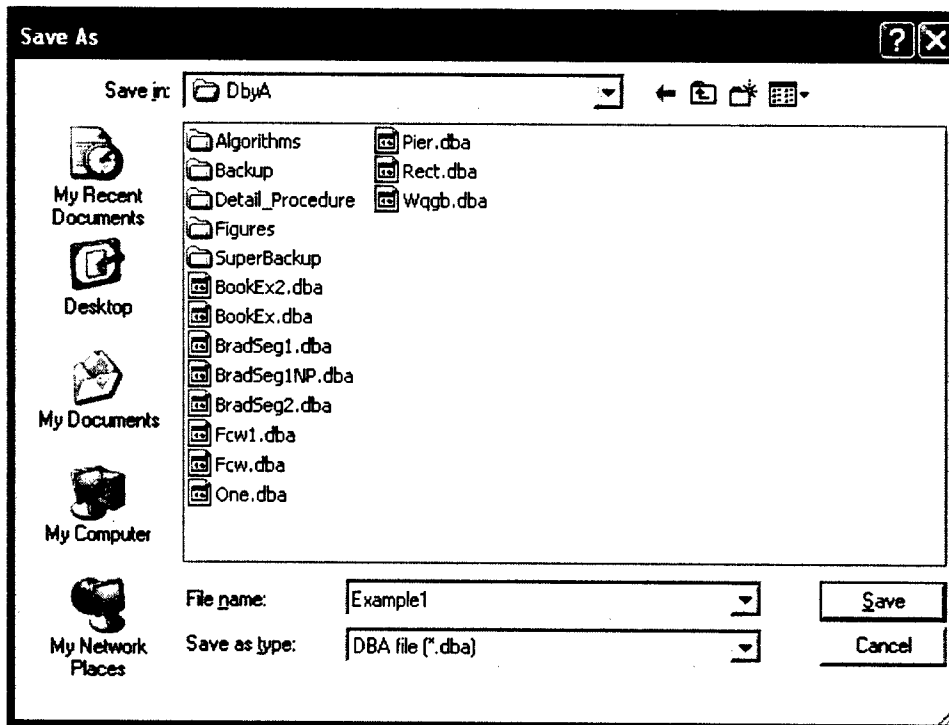

Figure A18. Save the model under a new file name

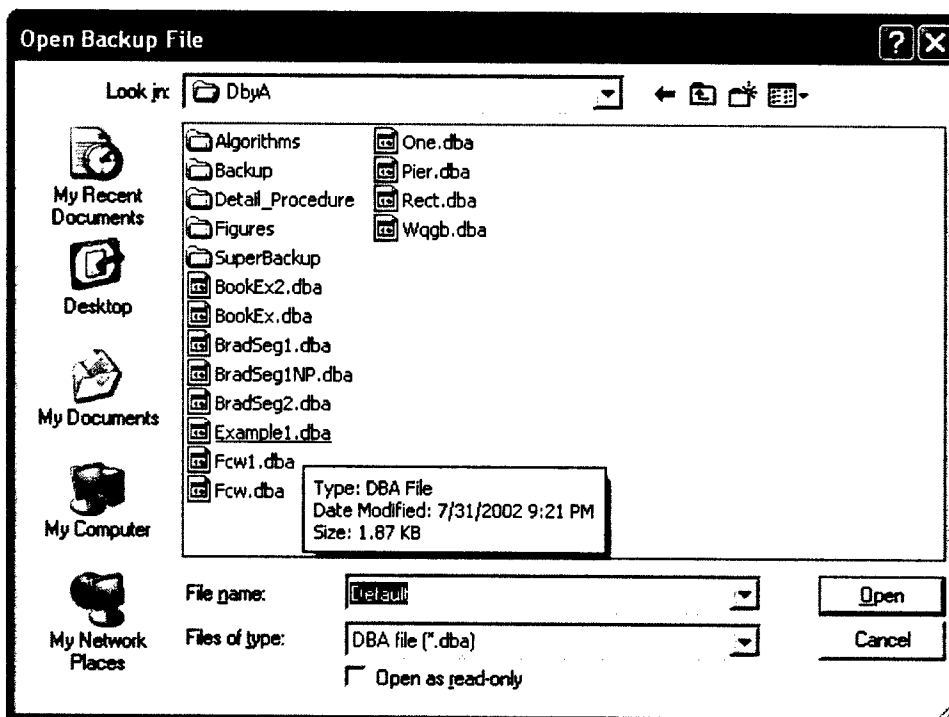

Figure A19. Open an existing backup file

The user will now continue to develop the model. The plot currently displays Dimension Set (Dim Set) 1, which includes the parameters that define the Outside Shape of the model. Only the height of the rectangular spillway shape can be changed at this time. This parameter is being changed to 18 ft, 1 in., in Figure A20 to give the clear floor height in the example problem. Dimensions can be changed by highlighting and replacing the default values.

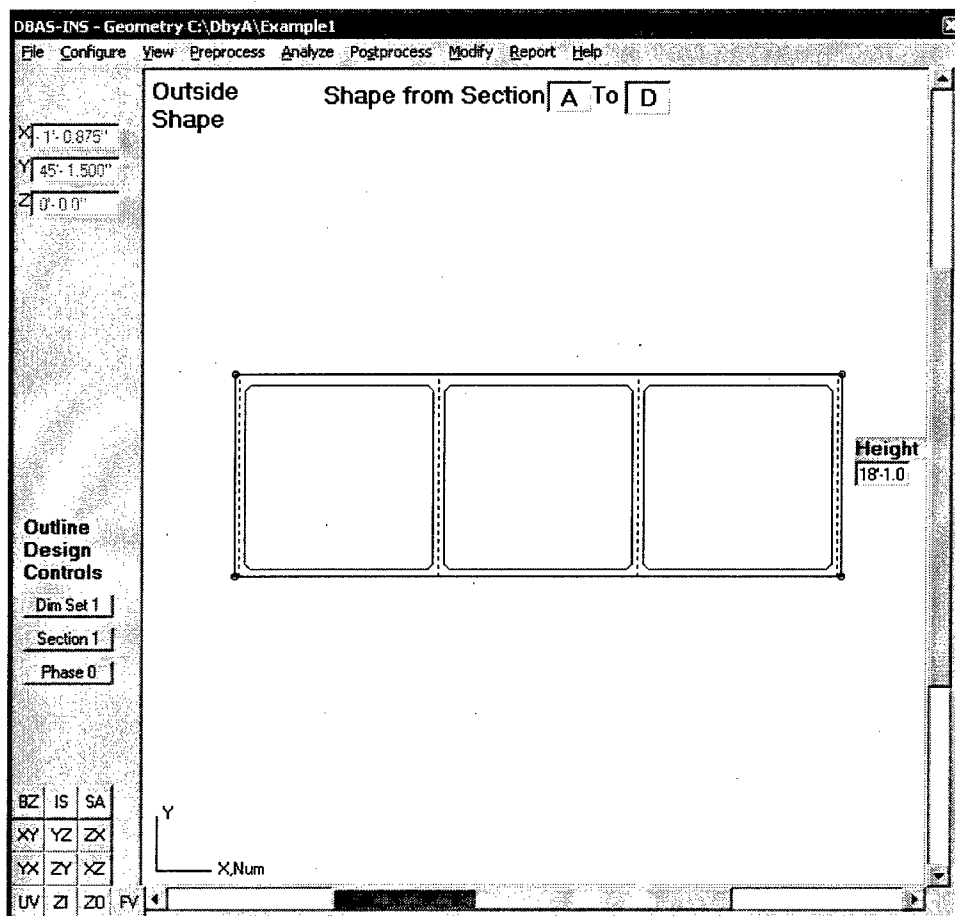

Figure A20. The cross section height is changed to 18 ft, 1 in.

After updating the view to reflect the change in height, the Outline Design Control - Dim Set 1 is clicked to switch to Dim Set 2, which displays the slab thicknesses shown in Figure A21. All are currently set to the default value of 1 ft, 0 in.

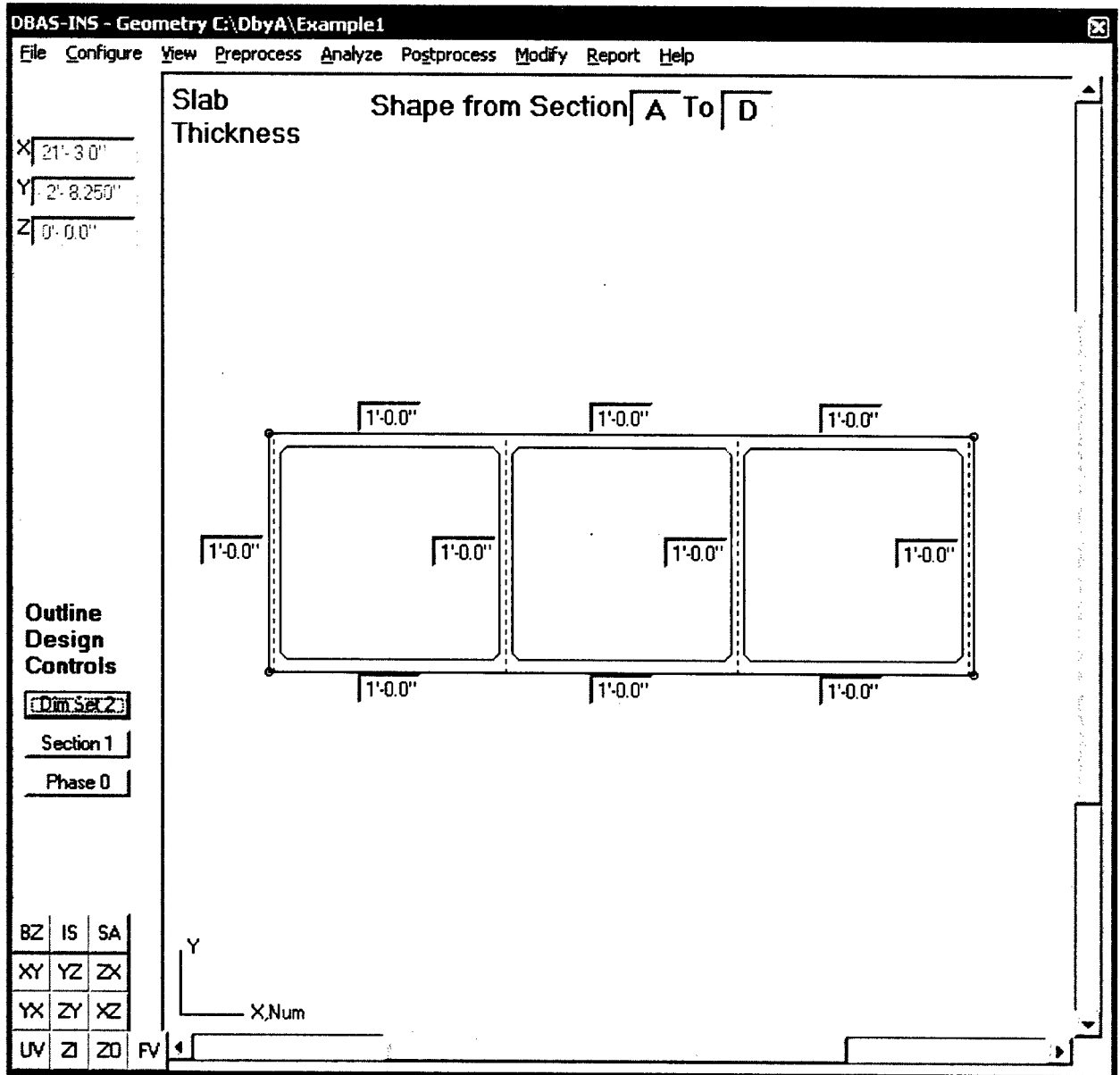

Figure A21. Slab Thickness parameters

Nawy (2000)<sup>1</sup> assumed a floor slab thickness of 7 in., so the thicknesses of the bottom slabs must be changed to 0 ft, 7 in., as shown in Figure A22.

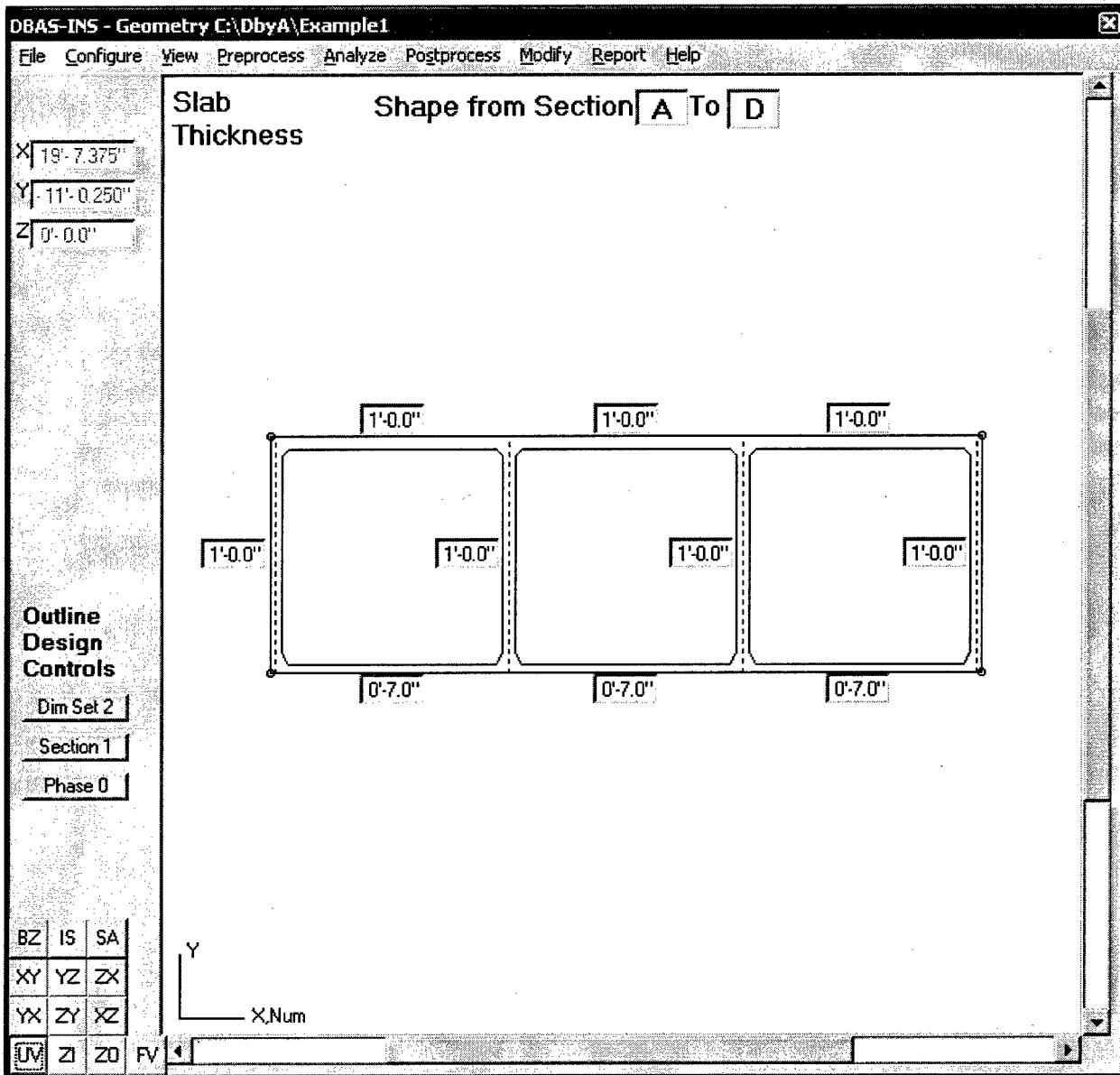

Figure A22. Change bottom slab thicknesses to 7 in.

The final dimension set (Dim Set 3) controls the tapers at slab intersections. Clicking the Dim Set 2 button accesses this set. Taper numbers are displayed at all joints as shown in Figure A23.

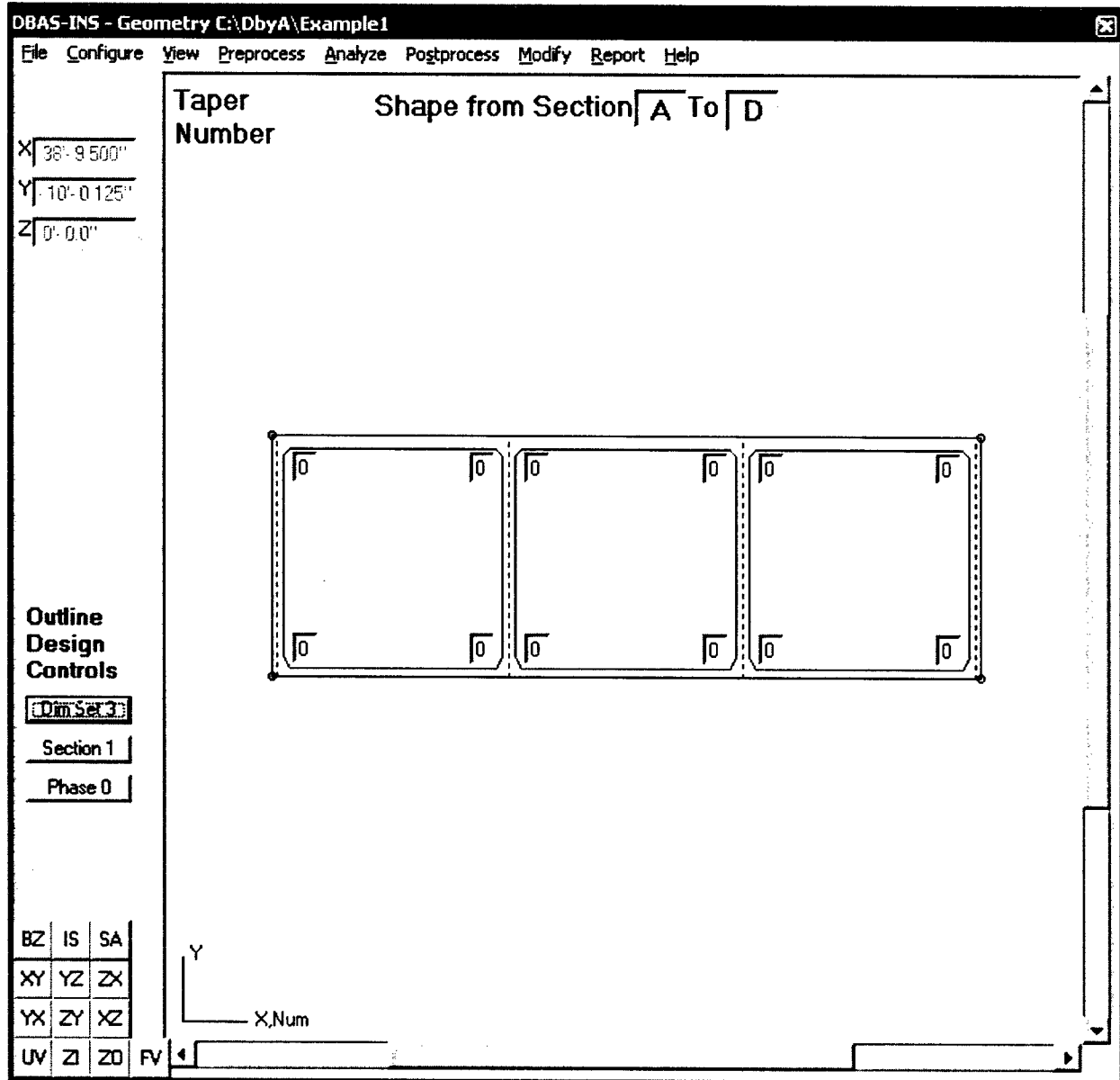

Figure A23. Taper Numbers are displayed in Dim Set 3

The default Taper Number, 0, has a Run of 12 in. and a Rise of 18 in., as shown in the Taper Types form in Figure A24. Run is measured from the center line of the diaphragm wall, and Rise, from the top or bottom surface as defined in the main text of the DBAS-INS User Manual (Section 5.3.2.3). Taper Number 1 is defined with a Run of 12 in. and a Rise of 13 in. by clicking the Add button after entering the values. The new taper number is assigned to all joints along with the bottom slab by entering 1 in any of the taper number boxes (Figure A25). The program automatically updates all tapers along the bottom edge to Number 1 to force all bottom tapers to have the same rise. By assigning a smaller rise dimension along the thinner bottom slab, the net taper dimensions along the top and bottom are now the same.

**Taper Types**

Number	Run(in.)	Rise(in.)
0	12	18
1	12	13

**Add**

Figure A24. Taper Types form

DBAS-INS - Geometry C:\DbyA\Example1

File Configure View Preprocess Analyze Postprocess Modify Report Help

Taper Number Shape from Section **A** To **D**

X 17'-10.125"  
Y 4'-10.0"  
Z 0'-0.0"

**Outline Design Controls**

Dim Set 3  
Section 1  
Phase 0

BZ	IS	SA
XY	YZ	ZX
YX	ZY	XZ
UV	ZI	ZO

X,Num

Figure A25. Taper numbers are changed along the bottom slab

### 3.4 Update top view

Now that the spillway geometry is defined, the top view will be complete. It is displayed by selecting the Update Top View option under the Preprocess menu item. Figure A26 is the Top View form, showing the thickness of all slabs and the run for tapers that are not controlled by the taper numbers in the section outline discussed above. These are tapers between diaphragm walls. Figure A27 shows the effect of changing the leftmost Run Right value to 2 ft, 0 in. (The value was restored to 1 ft, 0 in., for the remainder of the problem.)

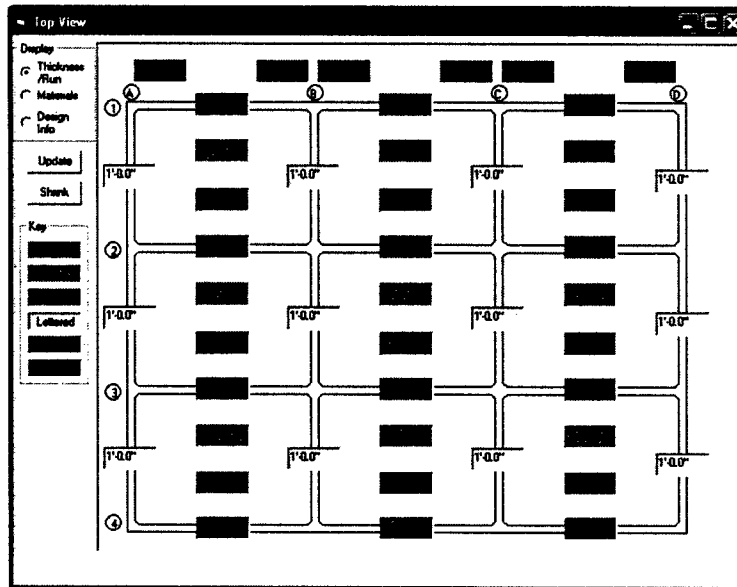

Figure A26. Adjust thicknesses and tapers in the Top View

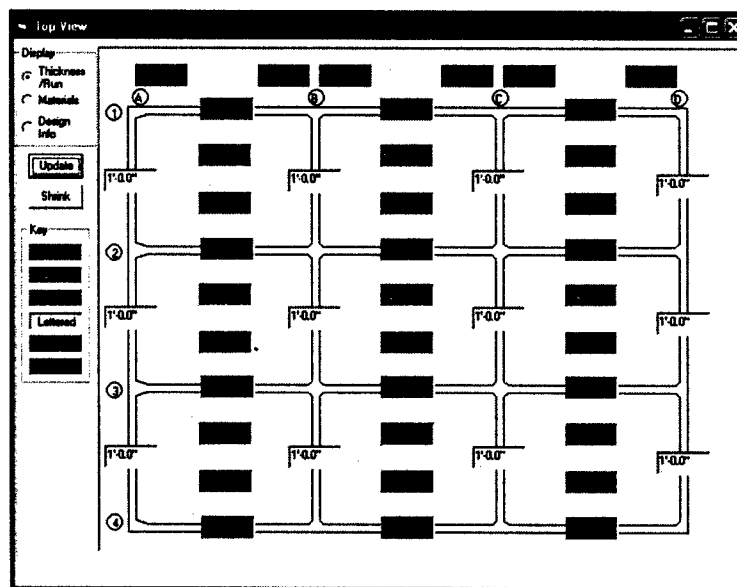

Figure A27. Leftmost Run Right parameter is changed to 2 ft, 0 in.

### 3.5 Generate and view finite element model

The final step in the Preprocessing phase is to generate the finite element mesh by selecting Generate Elements under the Preprocess menu item (Figure A7). This step automatically creates all Shell, Super Point, and Super Line finite elements based on the inputs described above. Figure A28 shows the shell elements from the west view (XY). Figure A29 was generated by clicking ZX to show the top view. Figure A30 displays the shell elements from an oblique angle after clicking the IS button.

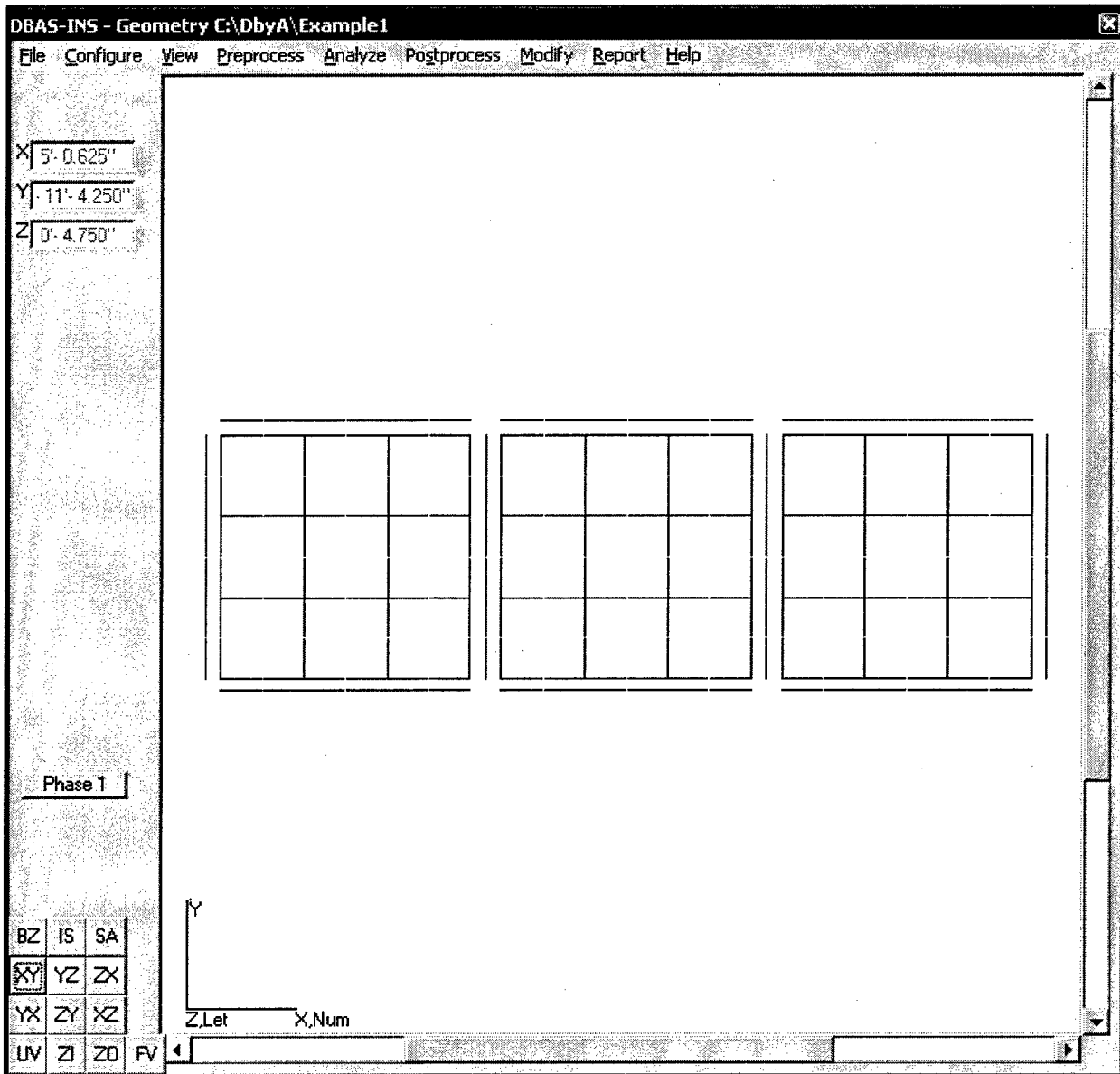

Figure A28. West view of shell elements

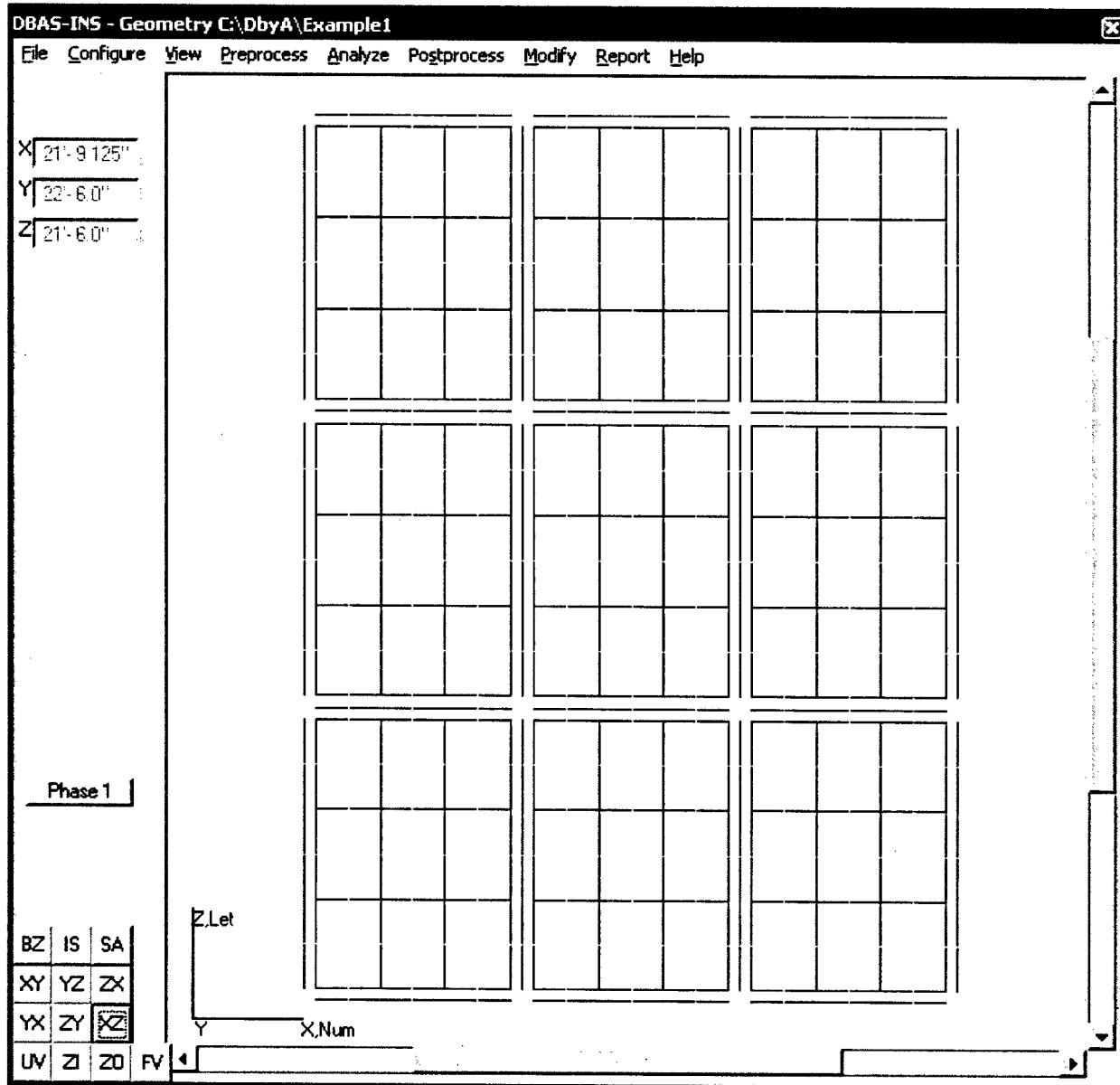

Figure A29. Top view of shell elements

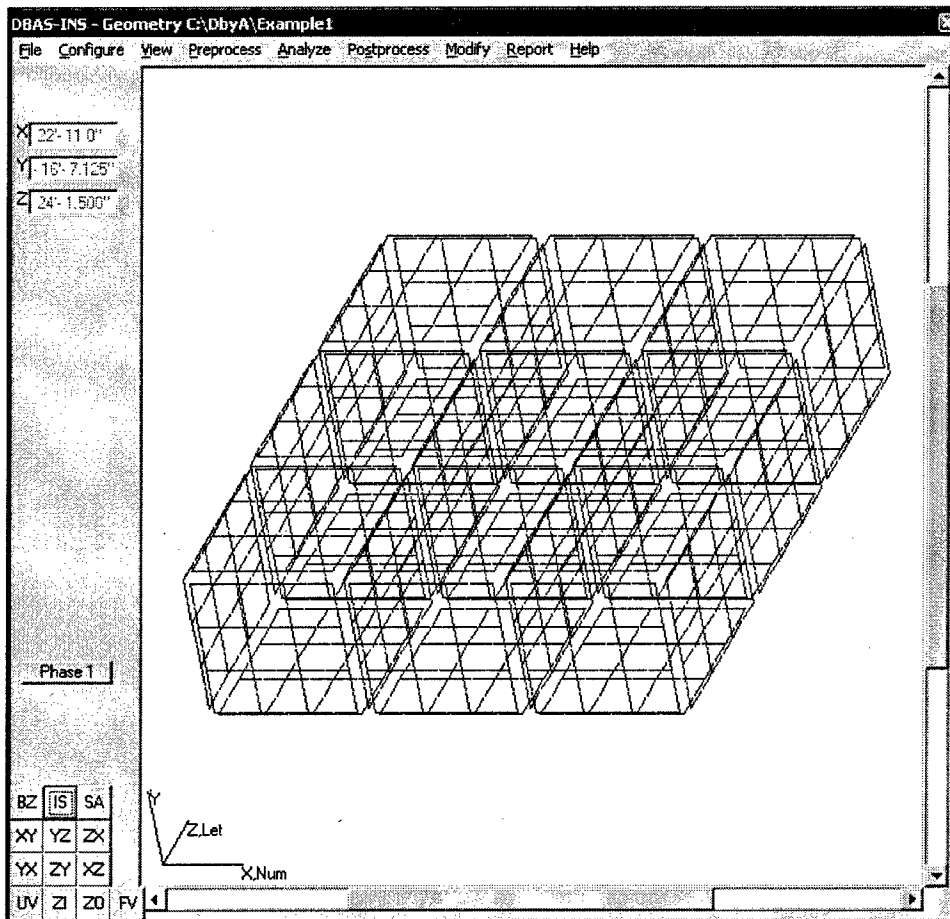

Figure A30. Oblique view of the shell elements

View options can be changed using the Plot Control form, which is opened by selecting Plot Control in the View menu item (Figure A31). The superelements can be added to the plot by checking Super Point and Super Line on the Plot Control form (Figure A32) and clicking UV on the DBAS-INS form. The top view of the entire finite element model is shown in Figure A33. Super Point elements are green, and Super Line elements are blue.

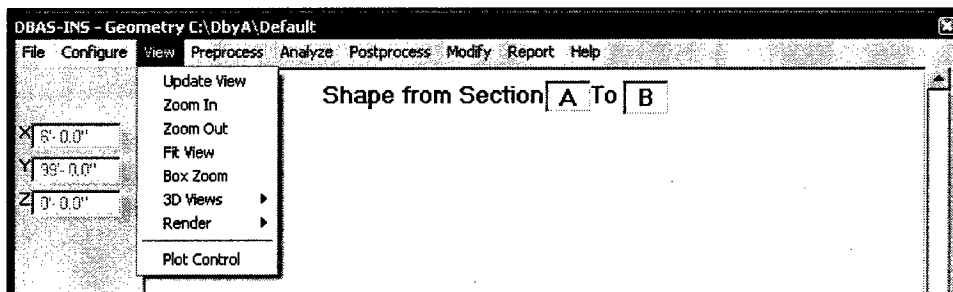

Figure A31. View menu item

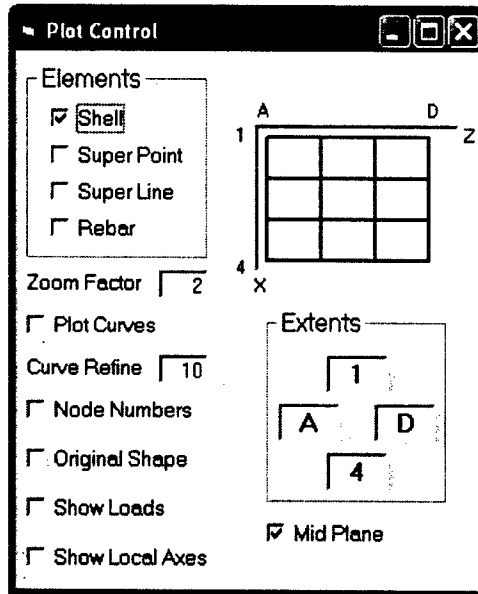

Figure A32. Plot Control form

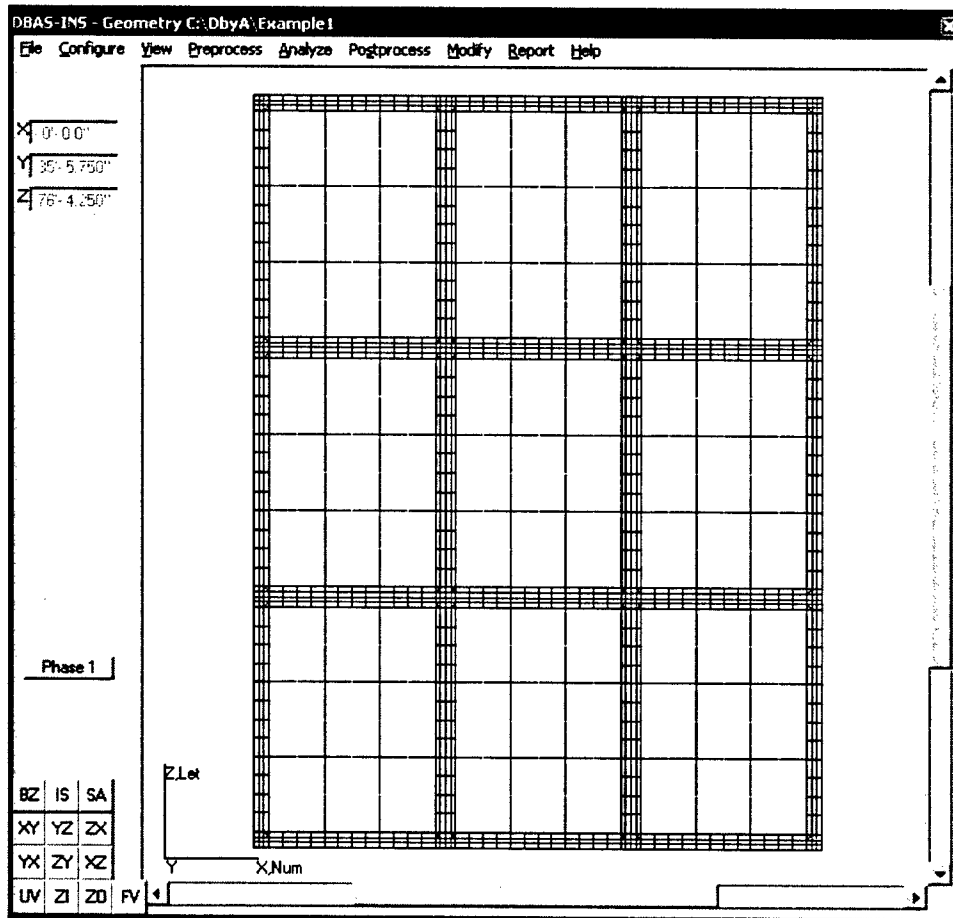

Figure A33. Top view of shell and super elements

In addition to the default views, the view angle can be set to any arbitrary direction by clicking the Set Angle (SA) button on the DBAS-INS form to display the View Rotation form shown in Figure A34. The angles can be changed using the sliding bars or by entering new values in the text boxes and clicking Apply. Clicking Update View (UV) on the DBAS-INS form displays the model from the new view angles, as shown in Figure A35.

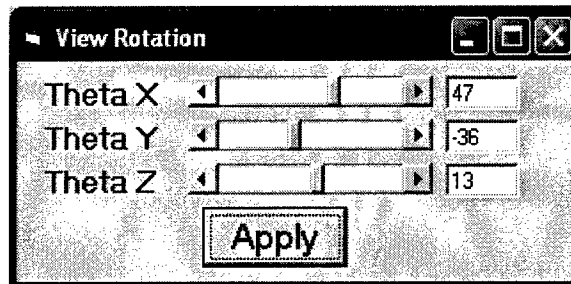

Figure A34. View Rotation form

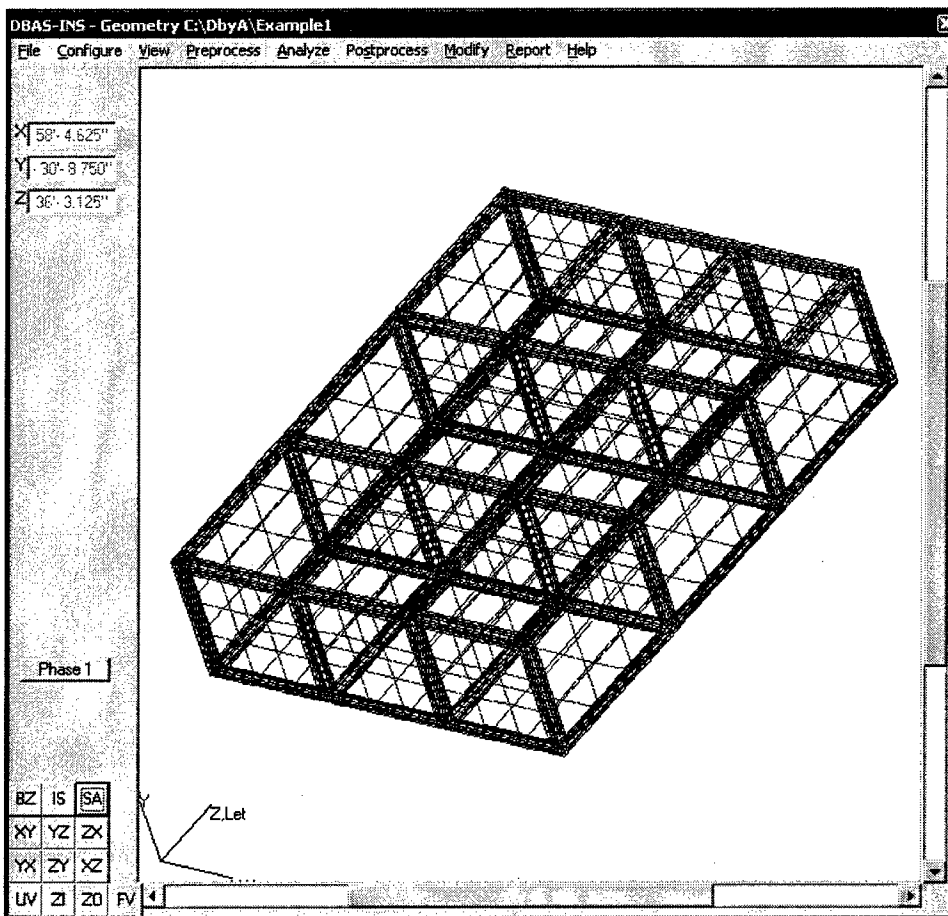

Figure A35. View from user-selected angles

The Plot Control form also allows the user to display a selected region of the model bounded by the section lines defined in the Extents frame. The section lines bounding the center panel are selected in Figure A36. The region is

bounded in red on the sketch above the Extents label. Figure A37 shows the effects of the Extent redefinition. The Box Zoom (BZ) command was used to enlarge the plot.

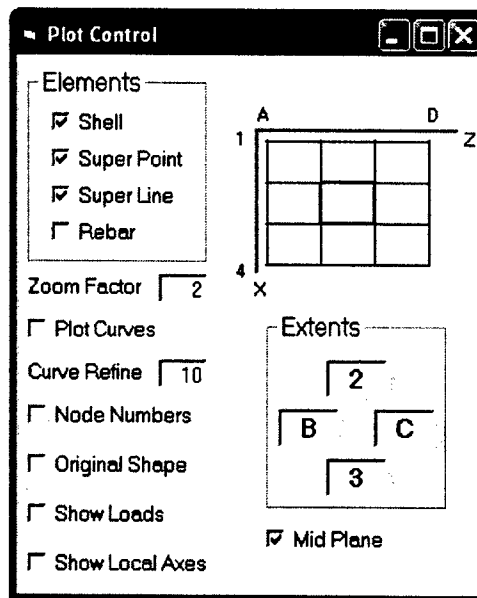

Figure A36. Define the Extents to display only the center panel

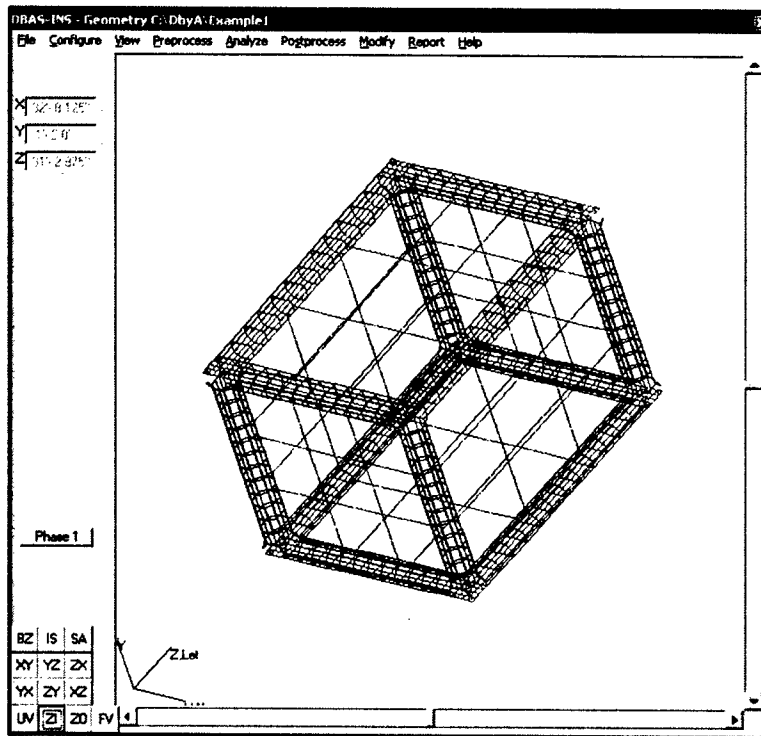

Figure A37. Plot of center panel region

To create Figure A38, Node Numbers were checked on the Plot Control form, and Super Point and Super Line were unchecked to display the node numbers. To make the node numbers legible or to locate an area of interest, use Zoom In (ZI) and Zoom Out (ZO) as needed. The node numbers will be needed in the next phase to define the locations of concentrated loads.

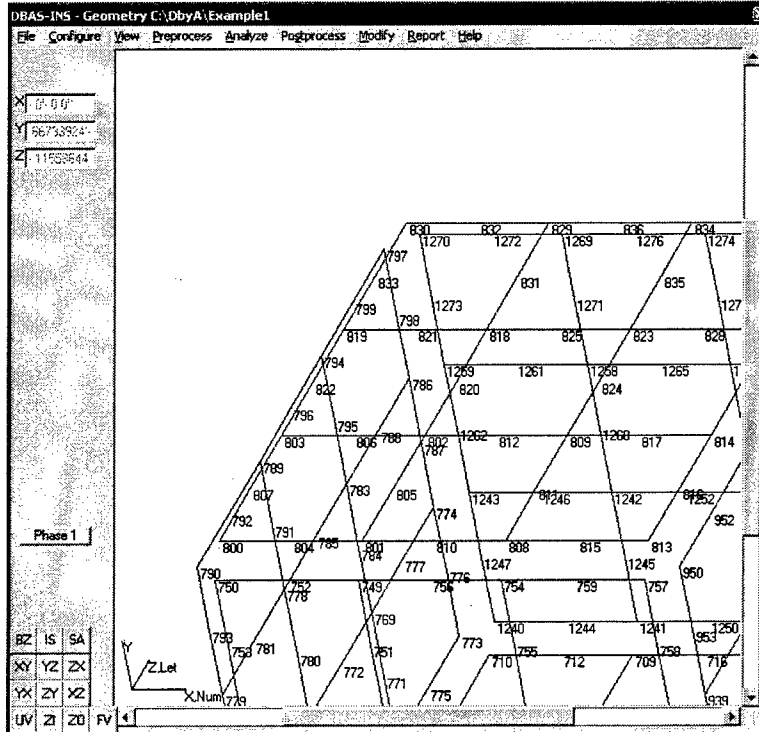

Figure A38. Display node numbers

## 4 Analyze

The Analysis phase follows preprocessing. Before running the finite element analysis, the user must define material properties and the displacement and force boundary conditions. These options are available under the Analyze menu item shown in Figure A39.

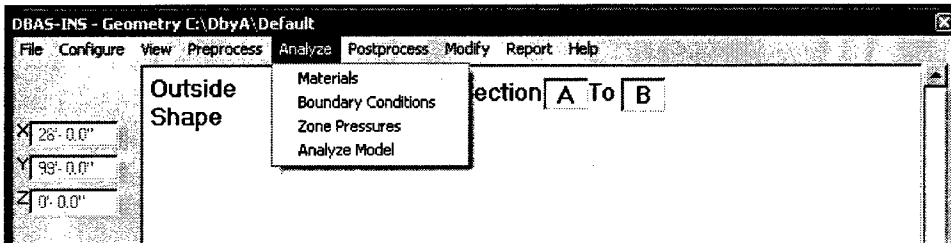
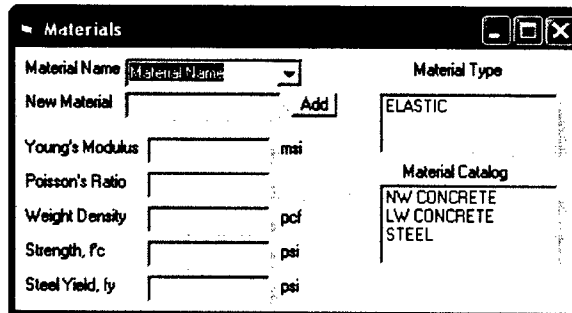

Figure A39. Analyze menu item

## 4.1 Materials

Material properties are assigned by selecting Materials under the Analyze menu item to display the Materials form shown in Figure A40. The slab elements are grouped by default according to their location in the model. The list of predefined groups is displayed on the Materials form by expanding the Material Name box (see Figure A41). For this example, the bottom elements (Figure A42) are composed of normal weight concrete. All other elements were assigned a density of 100.4 pcf in order to produce the desired pressure on the bottom of the segment.



The screenshot shows the 'Materials' dialog box. On the left, there are input fields for 'Young's Modulus' (msi), 'Poisson's Ratio', 'Weight Density' (pcf), 'Strength, f<sub>c</sub>' (psi), and 'Steel Yield, f<sub>y</sub>' (psi). On the right, the 'Material Type' is set to 'ELASTIC' and the 'Material Catalog' lists 'NW CONCRETE', 'LW CONCRETE', and 'STEEL'. A 'New Material' section with an 'Add' button is also visible.

Figure A40. Materials form

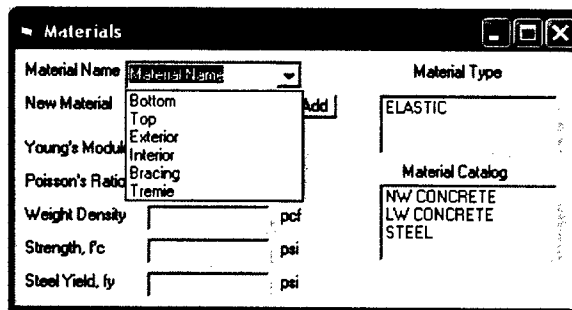

The screenshot shows the 'Materials' dialog box with the 'Material Name' dropdown menu expanded. The menu options are 'Bottom', 'Top', 'Exterior', 'Interior', 'Bracing', and 'Tremie'. The rest of the form, including the 'Material Type' and 'Material Catalog', remains the same as in Figure A40.

Figure A41. Material use groups

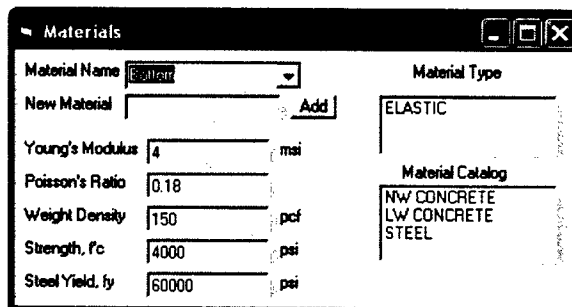

The screenshot shows the 'Materials' dialog box with numerical values entered in the input fields: 'Young's Modulus' is 4 msi, 'Poisson's Ratio' is 0.18, 'Weight Density' is 150 pcf, 'Strength, f<sub>c</sub>' is 4000 psi, and 'Steel Yield, f<sub>y</sub>' is 60000 psi. The 'Material Name' dropdown is now set to 'Bottom'. The 'Material Type' and 'Material Catalog' are also visible.

Figure A42. Properties assigned to bottom elements

## 4.2 Boundary conditions

The Boundary Conditions options are displayed by selecting that entry under the Analyze menu item (Figure A43). The Continuous Elastic Foundation option is unchecked, and the Floating condition is checked to produce the desired load for this example.

Figure A43. Boundary Conditions form

## 4.3 Adding load cases

The desired loading condition will be produced without adding load cases, but two are added in this example to demonstrate this option in the program. Figure A44 is the Fluid Depths form, which is displayed when the Zone Pressures option is selected under the Analyze menu item.

	A	B	C	D
Upstream	0	0	0	0
1	0	0	0	0
2	0	0	0	0
3	0	0	0	0
Downstream	0	0	0	0

Figure A44. Fluid Depths form

In Figure A45, 10 ft of water is added to the four cells on the corners of the model. The user first selects Load Case 1 (LC1), then enters the fluid levels and

clicks Accept. When 10 is entered in box A1, that water depth is defined for the cell bounded by section lines A, 1, B, and 2. Figure A46 shows the water level in those four cells by plotting thick blue lines above the bottom elements at the defined water level.

**Fluid Depths (ft.)**

	A	B	C	D
Upstream	0	0	0	0
1	0	10	0	10
2	0	0	0	0
3	0	10	0	10
Downstream	0	0	0	0

OK  
Cancel  
Accept

**Load Case**  
LC1

Nodal Forces

Figure A45. Define Load Case 1

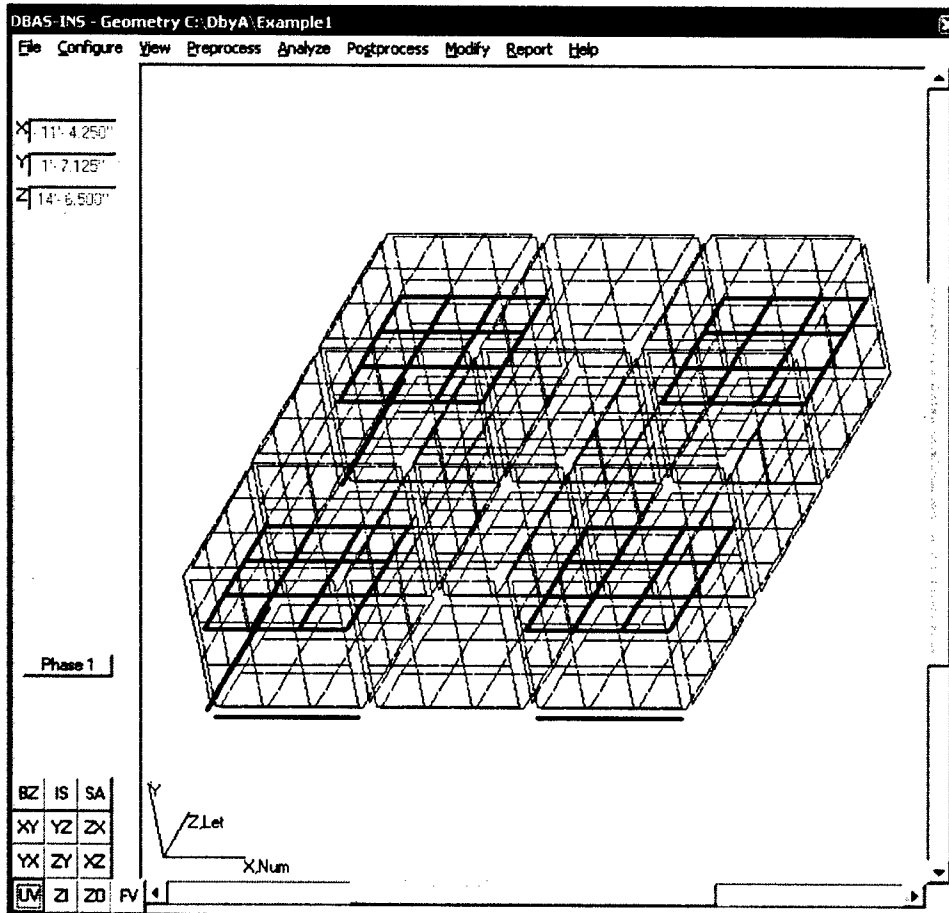

Figure A46. Water levels defined for LC1

Load Case 2 is nodal forces applied to the corners of the top middle panel. Figure A47 was plotted to show the node numbers as those points. The Extents

defined in Figure A36 are still in effect. For this load case, a 10,000-lb load (downward force in negative Y direction) is applied at Nodes 800, 813, 830, and 837 by choosing LC2 on the Fluid Depths form, then clicking Nodal Forces to display the form shown in Figure A48. The Impose button is clicked after entering the loads for each node number. Arrows showing the load locations are plotted as shown in Figure A49.

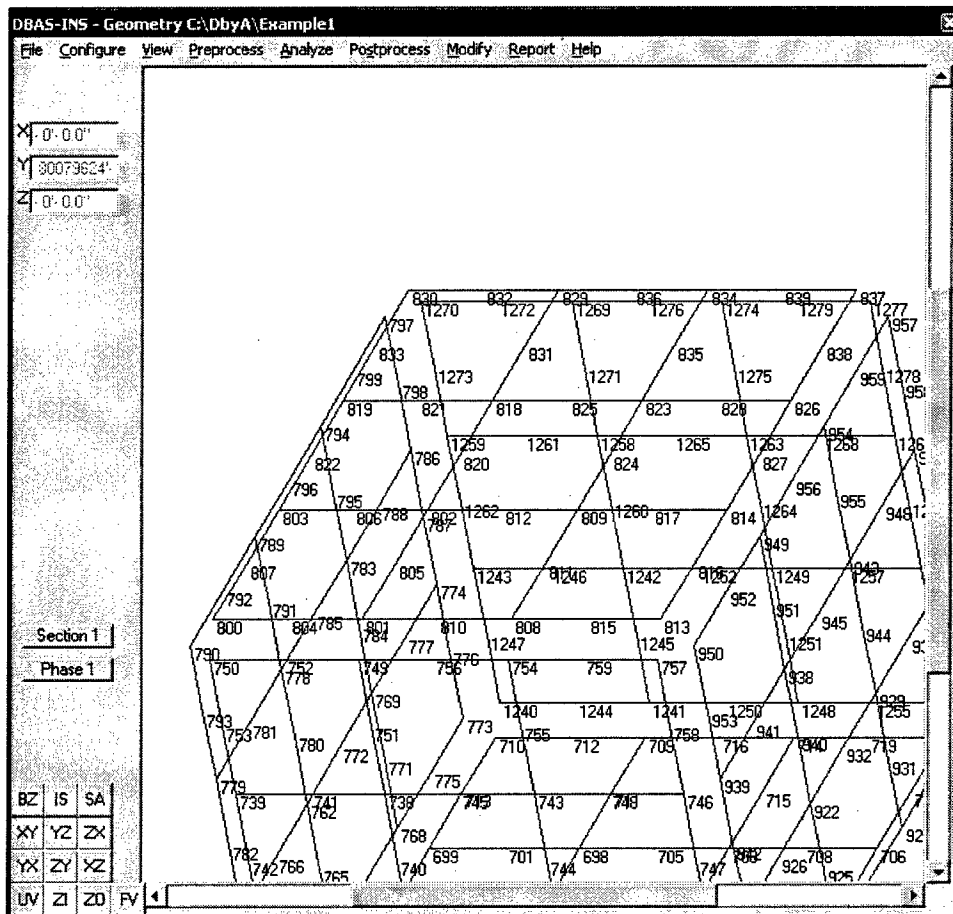

Figure A47. Display node numbers on the top, center panel

Figure A48. Nodal Force form

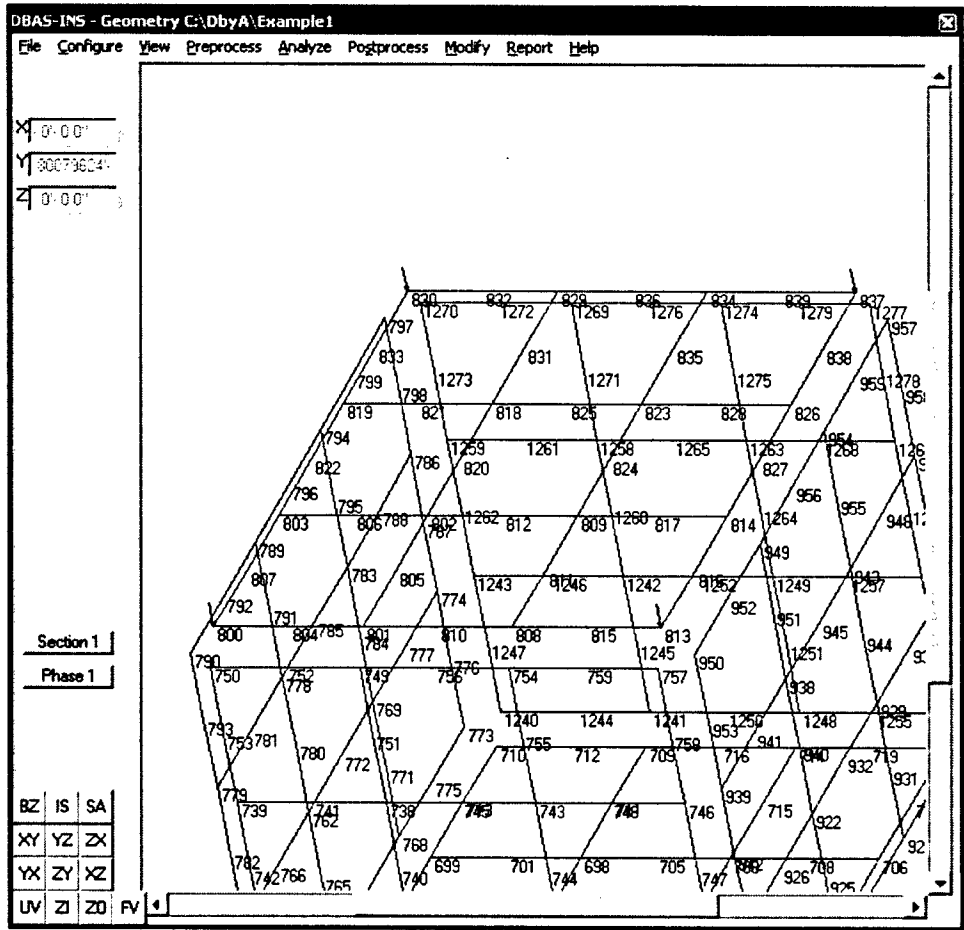

Figure A49. Load vectors displayed on plot

#### 4.4 Analyze model

The finite element model is analyzed for all load cases by selecting the Analyze Model option under the Analyze menu item. Analysis can take several minutes. The status bar in Figure A50 tracks the most time-consuming operation, factoring the stiffness matrix.

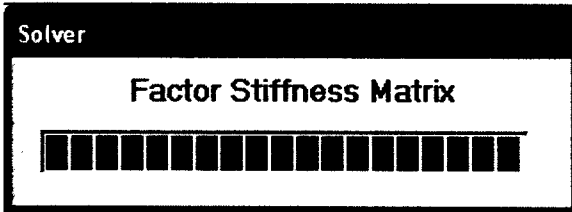

Figure A50. Factoring Stiffness Matrix status bar

#### 5 Postprocess

A deflected shape plot is displayed upon completion of the finite element analysis. Additional postprocessing is controlled by options under the Postprocess menu item, shown in Figure A51. and under the View | Render

options shown in Figure A52. (Note that the shell refinement was increased to 4 by 5 elements in the top and bottom slabs to give the results displayed in this section.)

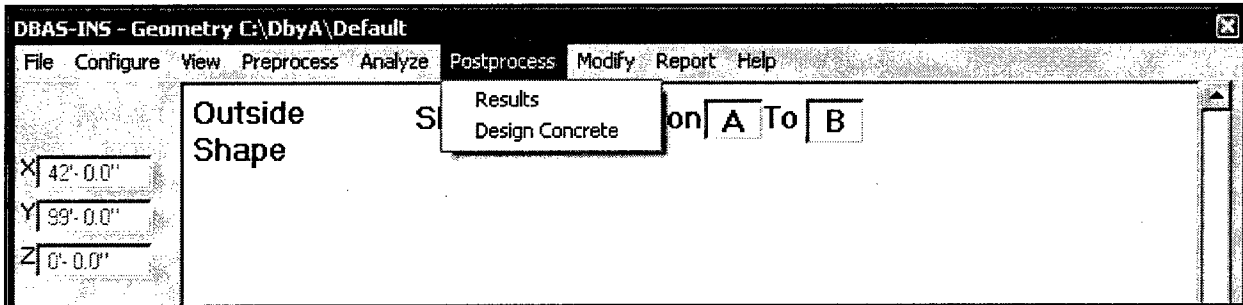

Figure A51. Postprocess menu item

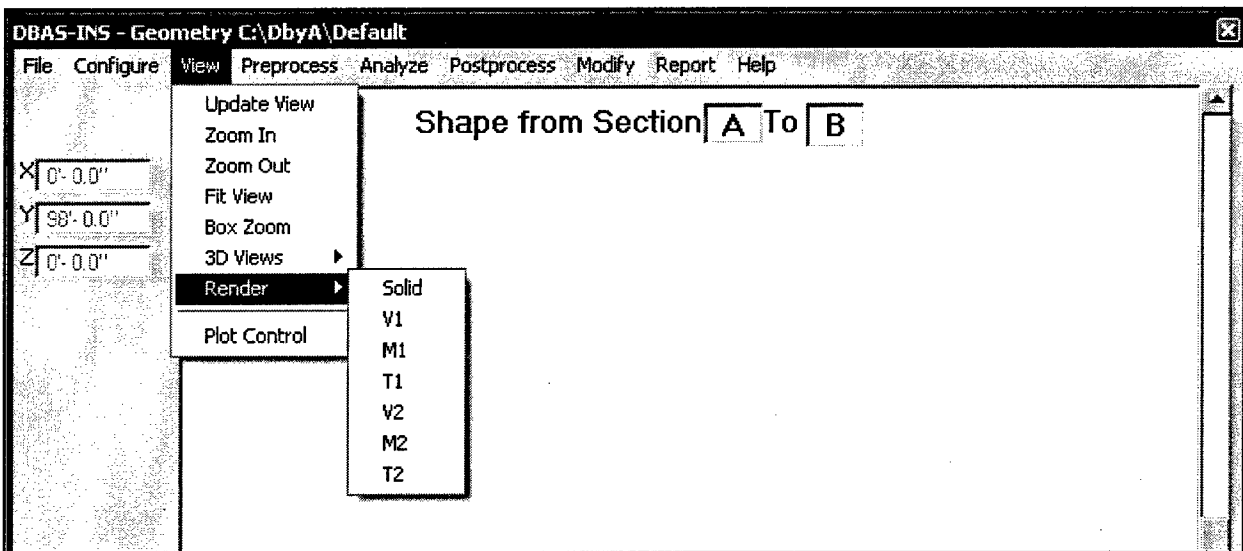

Figure A52. View | Render menu item

### 5.1 Deflected shapes

Results are plotted for the load case selected on the Fluid Depths form. Figure A53 shows the results from the No (Internal) Pressure load case. Deflection due to upward pressure on the bottom slabs is obvious. The default deflection multiplier is 1,000. This can be changed on the Results form, which becomes visible after the analysis is complete (Figure A54) or may be displayed by selecting the Results option under the Postprocess menu item.

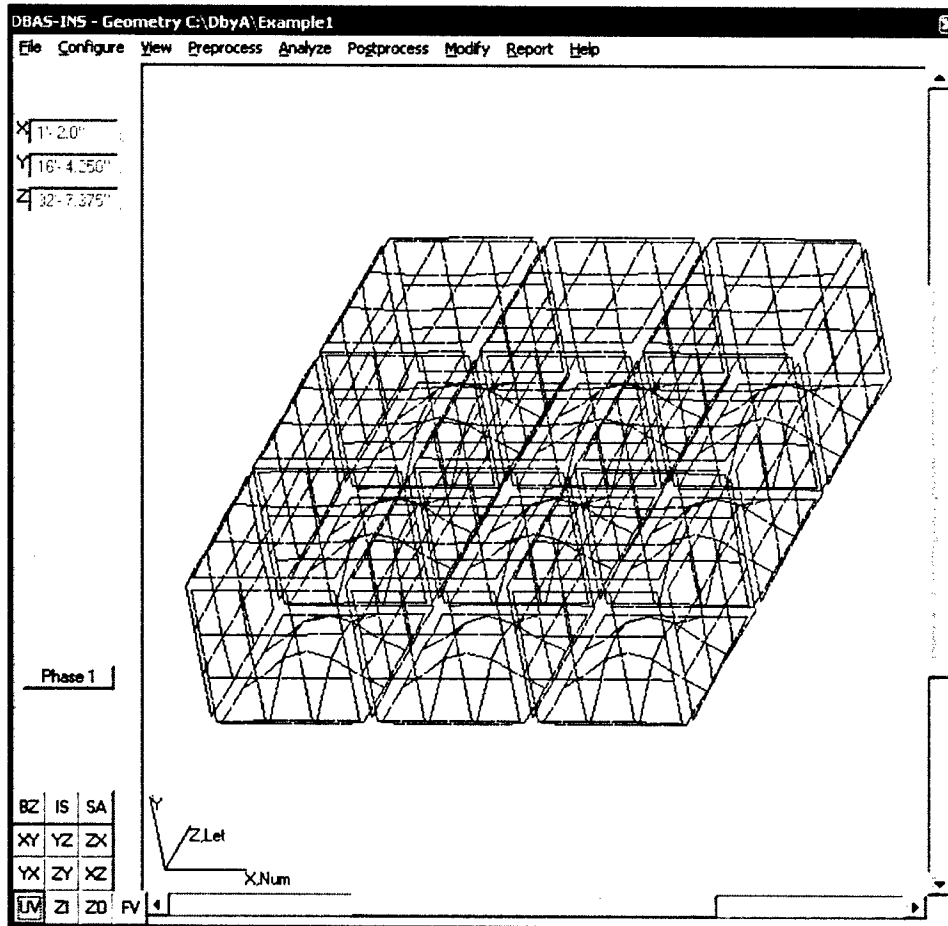

Figure A53. Deflected shape plot with no internal fluid pressures

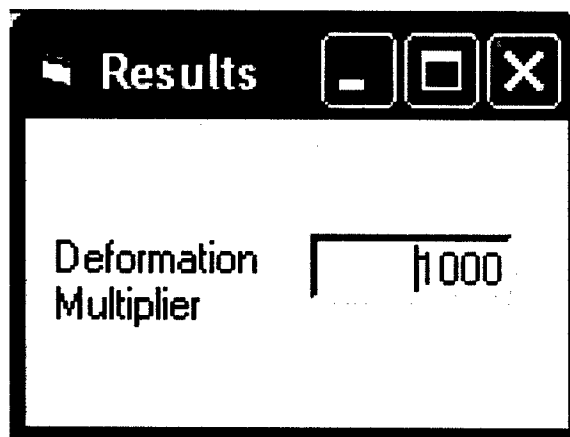

Figure A54. The Deformation Multiplier can be changed on the Results form

The results from other load cases can be displayed by selecting the desired load case in the Fluid Depths form shown in Figure A44. Figure A55 is the result of LC1 with the four corner cells filled to a depth of 10 ft. There is little bending

in the four corner slabs because the internal water pressure counteracts the upward pressure on the bottom of the segment.

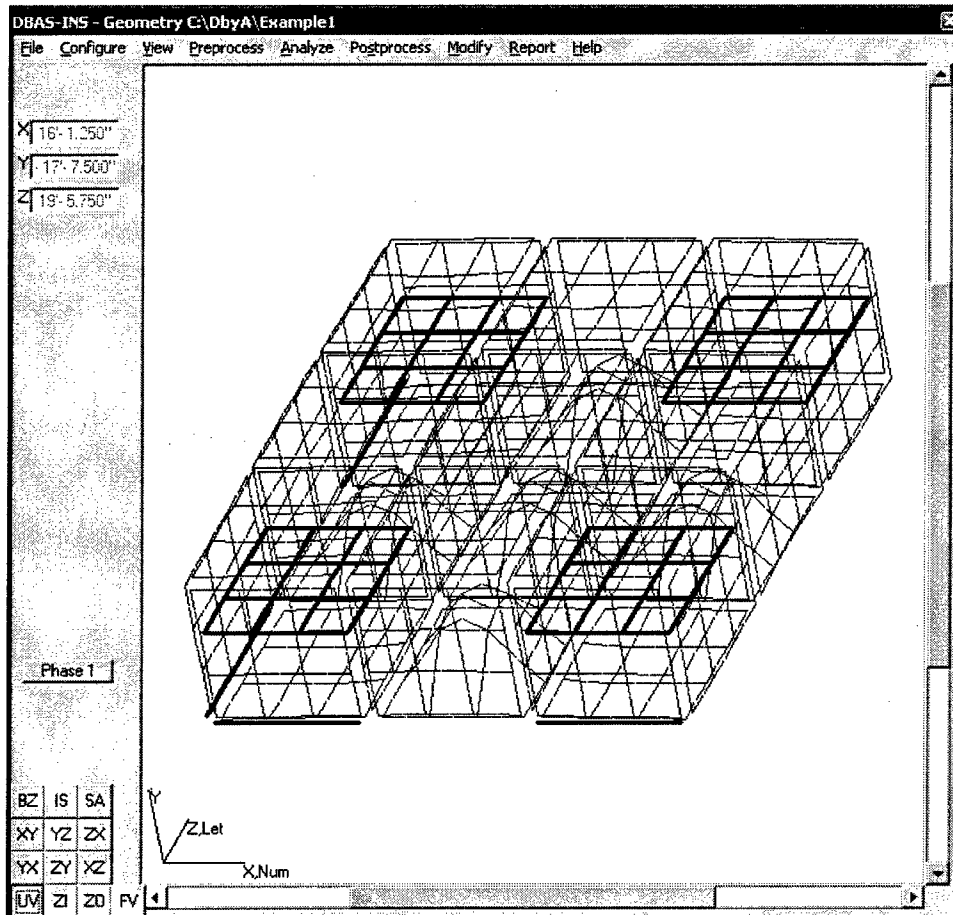

Figure A55. IS view of LC1 results

Checking Super Point and Super Line in the Plot Control form will plot the deflected shape of the superelements. This operation is computationally intensive because shell node deflections must be transformed to determine the deflections of all master and slave nodes in the superelements. The user should consider reducing the Extents of the plot before updating the view when superelement plotting is turned on. However, all superelements must be plotted before stress results on superelements are viewed because information calculated during the plot is used to calculate stresses for display and to determine shear, moment, and thrust. This will occur automatically if required. Figure A56 shows the deflected shape under LC2 with superelements displayed. Obviously, most deformation occurs in the shell elements.

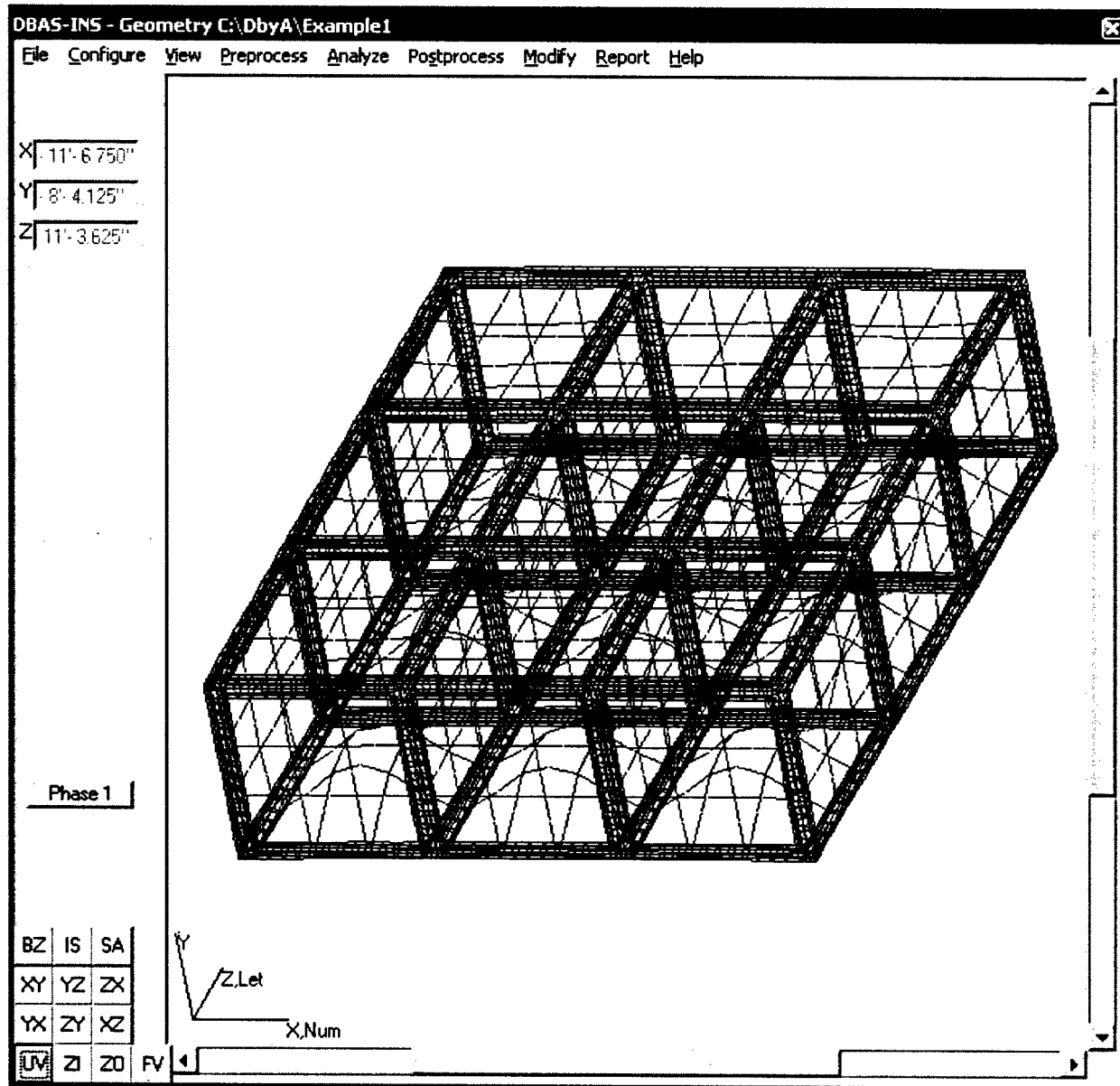

Figure A56. Deflected shape under Load Case 2

## 5.2 Stress results

Stresses on exposed faces of the model are plotted using the View | Render | Solid menu option. The initial plot will show stresses in the X direction. Figure A57 shows the flexural stresses in the bottom slab. The stresses calculated from superelements are not averaged with those from the shells, creating a slight discontinuity in the contours. This is expected, and improves with greater mesh refinement.

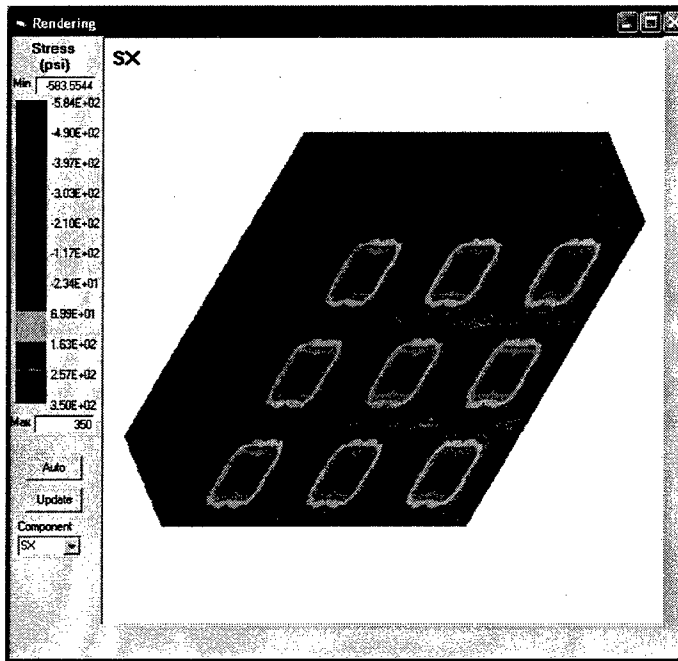

Figure A57. X-direction stresses in superelements by center panel

The stress component can be changed in the Component box at the bottom left side of the form. Figure A58 shows the Z stress component. The results are similar to X stresses with somewhat different magnitudes because the panel length is longer in the Z direction.

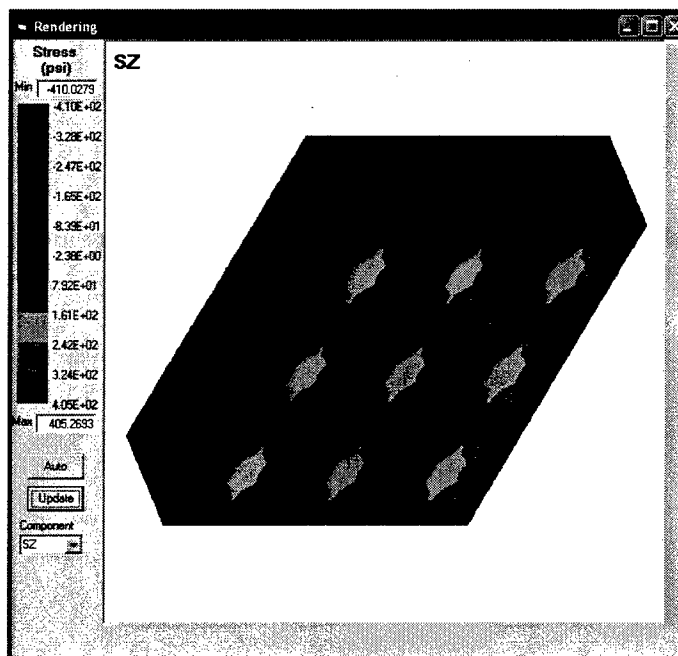

Figure A58. Z-direction stresses in superelements by center panel

### 5.3 Shear, moment, and thrust results for shells

Plots of shear, moment, and thrust on shell elements are also initiated through the View | Render menu item. Any of the six components shown in Figure A52 can be selected. Figure A59 is a plot of moment in the 1,1 direction on shells surrounding the center panel. The local directions are consistent for each of the four shell types as follows:

- Bottom – 1 is X direction, 2 is Z direction
- Top – 1 is X direction, 2 is Z direction
- Numbered – 1 is X direction (horizontal), 2 is Y direction (vertical)
- Lettered – 1 is Z direction (horizontal), 2 is Y direction (vertical)

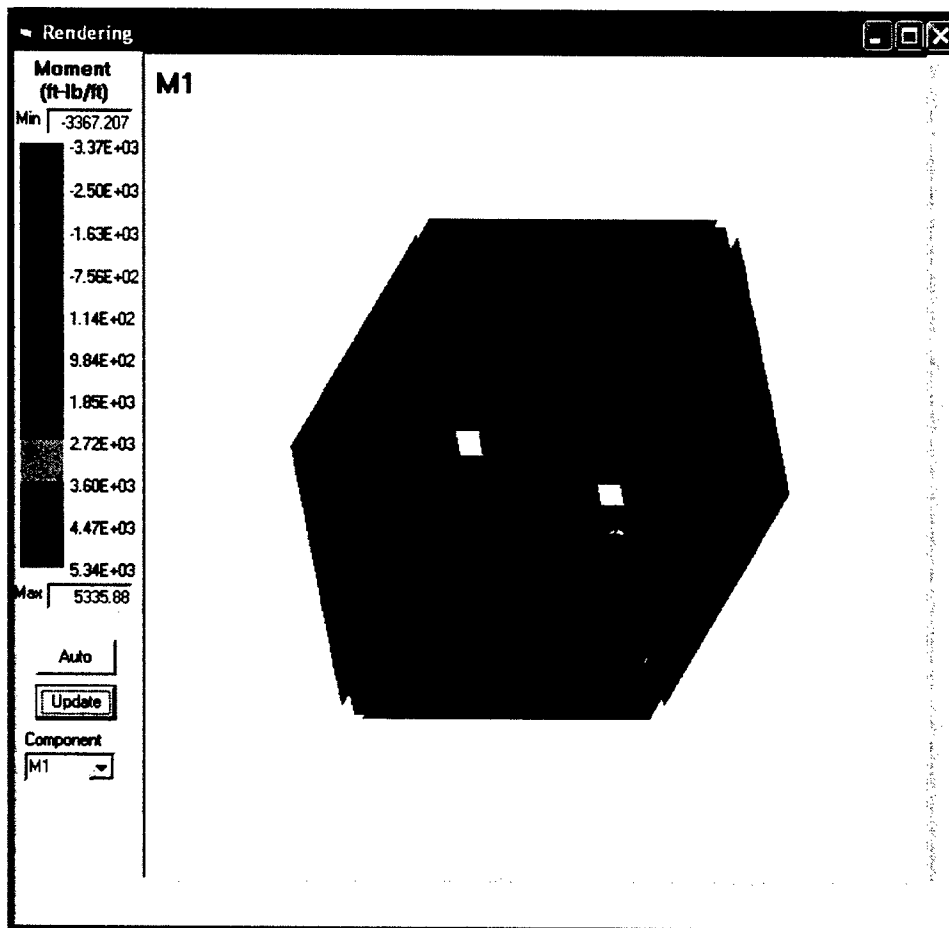

Figure A59. M1 results

The local axes can be superimposed on the slabs by checking the Show Local Axes box on the Plot Control form (Figure A36). Figure A60 shows the M2 component results with this option checked.

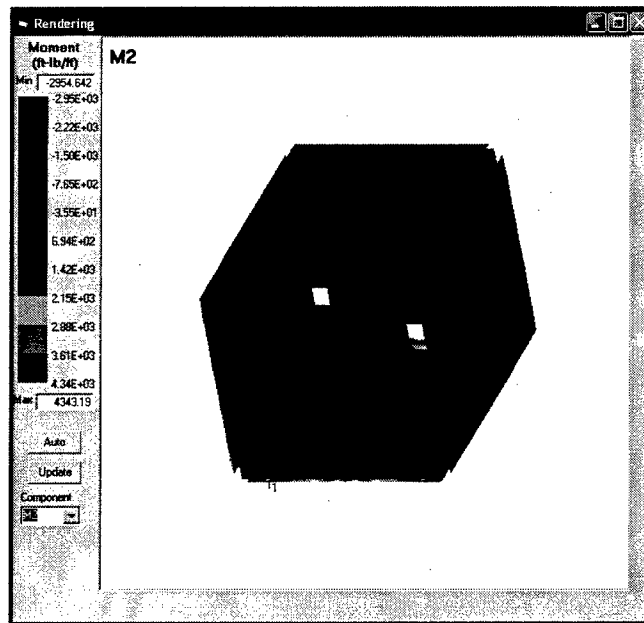

Figure A60. M2 results

Shear, moment, and thrust values can be displayed from any view. The view direction in the rendering is the same as that in the latest update of the main DBAS-INS form. Figure A61 shows moments in the bottom slabs. In Figure A62 the contour intervals are changed by entering the desired minimum and maximum in the text boxes at the top and bottom of the contour bars on the left side of the form. In this case, the range is changed from -4,000 to 6,000 ft-lb/ft. Clicking the Auto button before plotting will change the Min and Max to enclose the range of values on the entire structure.

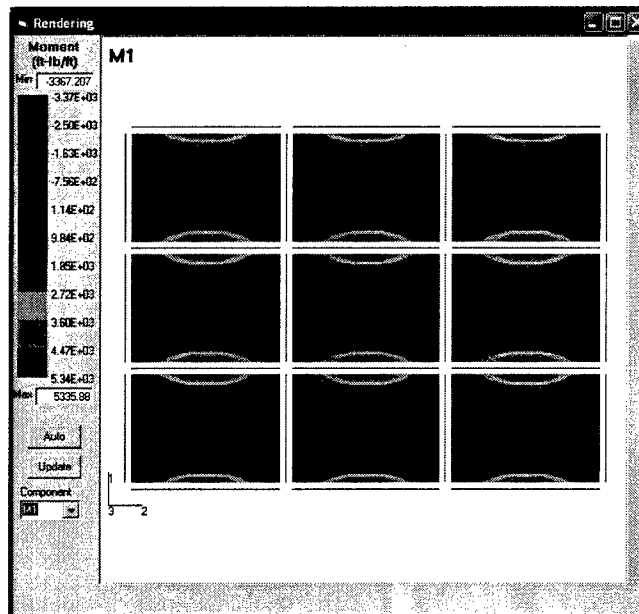

Figure A61. Moments on the bottom slabs

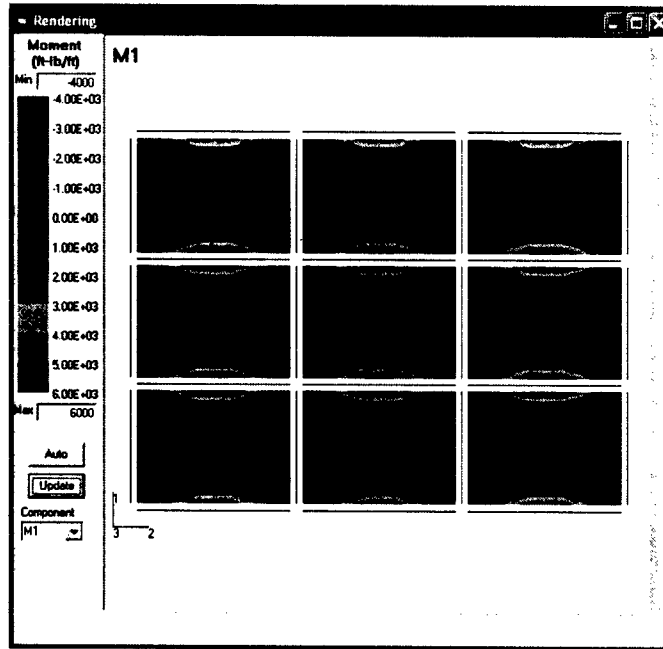

Figure A62. Bottom slab moments with the manually adjusted contour intervals

Figure A63 shows moments in the Z direction on the bottom slab. Magnitudes of negative moments are somewhat lower than moments across the short span (X direction), as expected. Figures A64 and A65 plot out-of-plane shear.

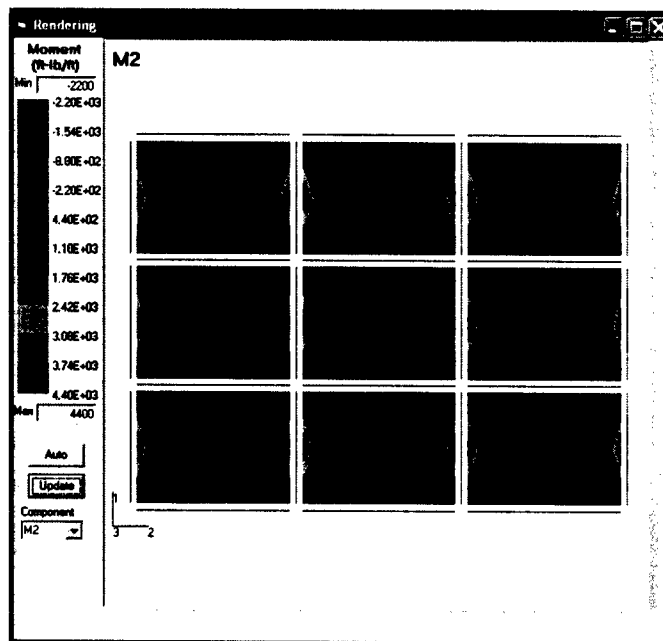

Figure A63. Z-direction moments (2 axes on bottom slab)

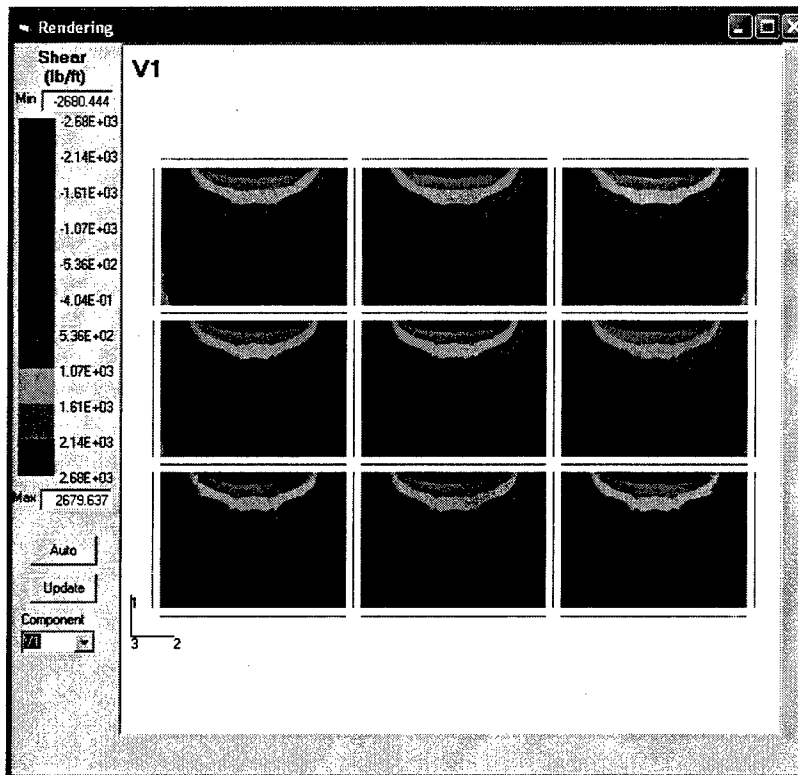

Figure A64. Out-of-plane shear – 1 direction

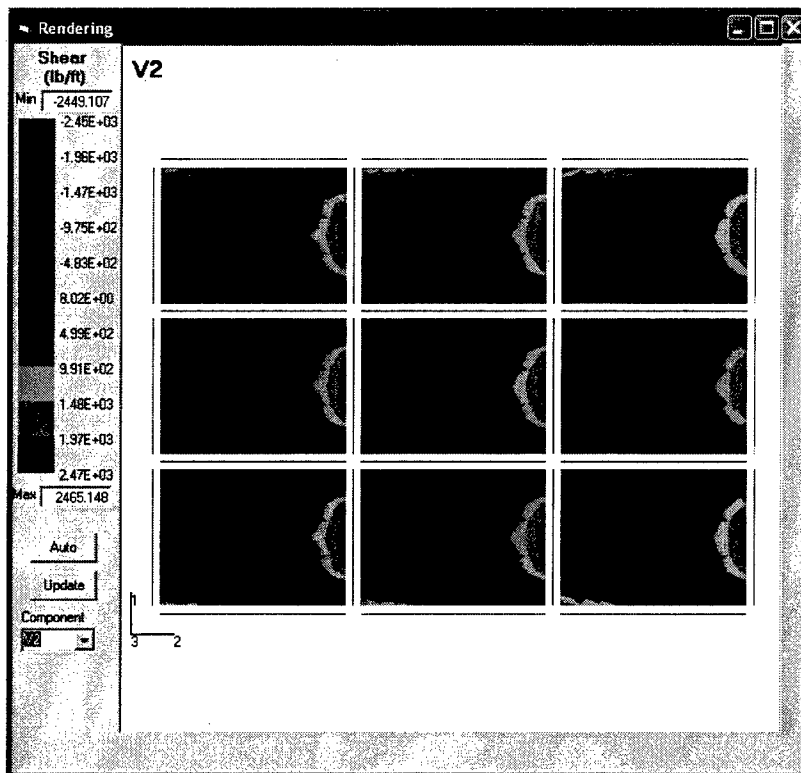

Figure A65. Out-of-plane shear – 2 directions

## 5.4 Cross-section stress plots

Left-clicking the Phase 1 plotting button on the DBAS-INS form switches plotting to Phase 2 to output stress contours on cross sections of the model. The location of the desired plot selected in the Plot Control form is shown in Figure A66. Figure A67 is a plot of Z stresses along Section Line A. Stress values are evaluated in both the shells and superelements in the cross section. The results show a negative moment caused by the distribution of the weight of diaphragm walls in the floating condition.

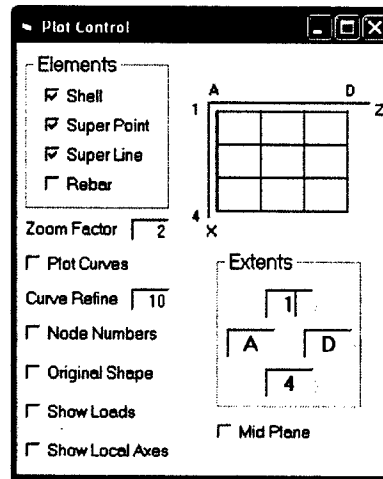

Figure A66. Location of cross-section plot is shown in Plot Control form

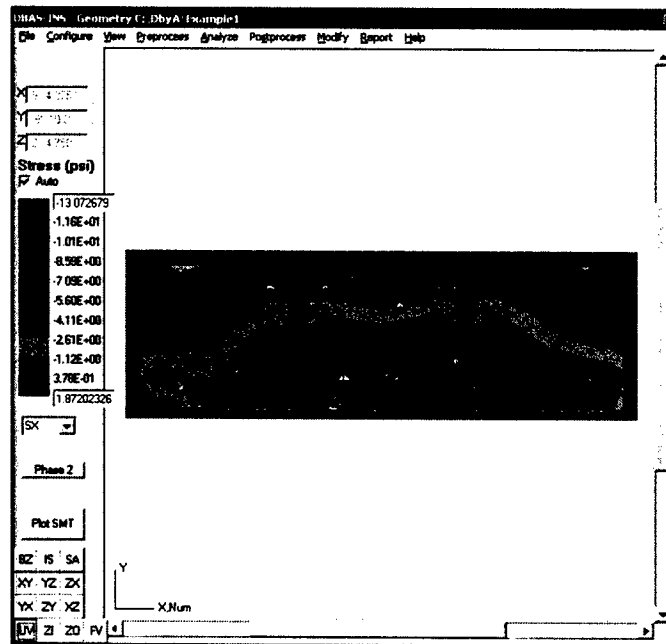

Figure A67. X-direction stresses along Section A

## 5.5 Shear, moment, and thrust diagrams

The plotted cross section is changed by entering B in the Extents frame of the Plot Control form (Figure A68). The Shear Moment Thrust form is opened by clicking Plot SMT on the DBAS-INS form. The Select Box button on the SMT form (Figure A69) is then clicked to designate a region for SMT plotting.

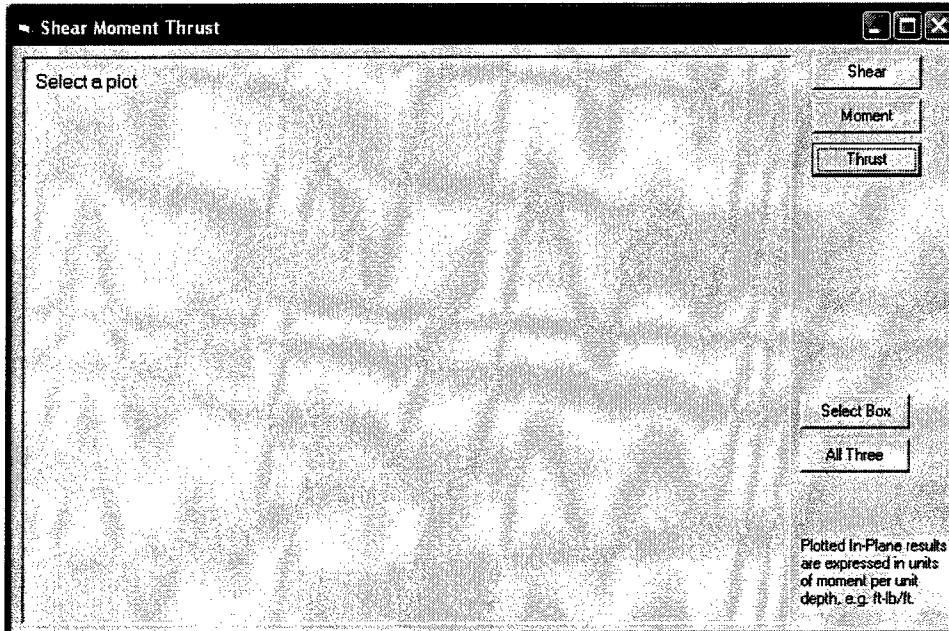

Figure A68. Shear, moment, and thrust form

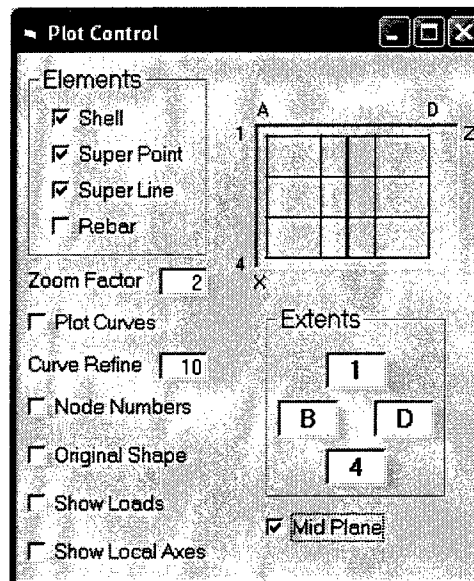

Figure A69. Enter B in Extents to plot midplane cross section between lines B and C

After clicking Select Box, a region is identified by clicking the mouse at opposite corners on the cross-section plot, as shown in Figure A70. The SMT diagram automatically updates to show results for the designated region (Figure A71).

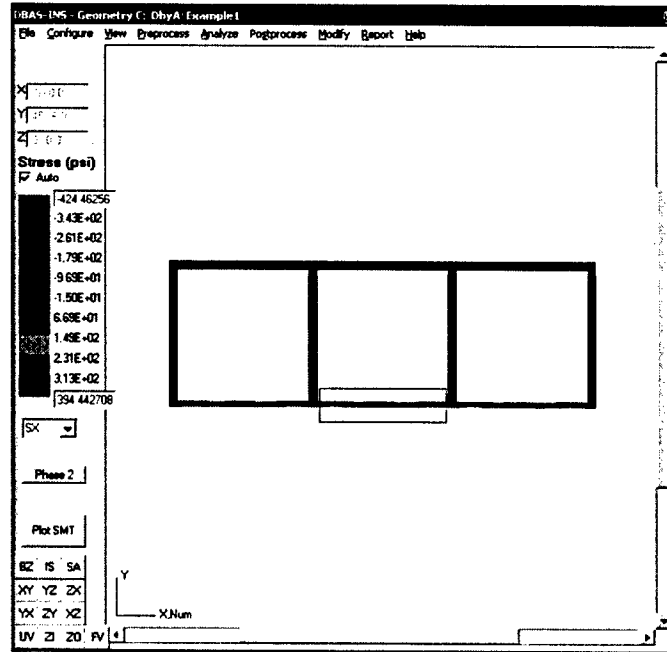

Figure A70. Region selected for SMT plot

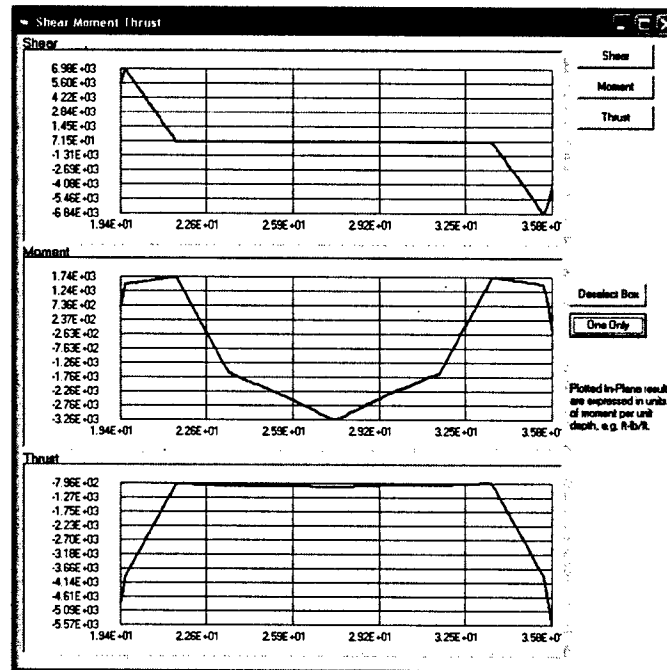

Figure A71. All three SMT plots

## 5.6 Design concrete

The concrete design can be viewed by opening the Top View (Preprocess | Update Top View), clicking Design Info, and clicking the text box for the desired slab. The text boxes were shrunk in Figure A72. The Design Results shown in Figure A73 can be compared with the results from the textbook solution (Table A1 and Figure A1b).

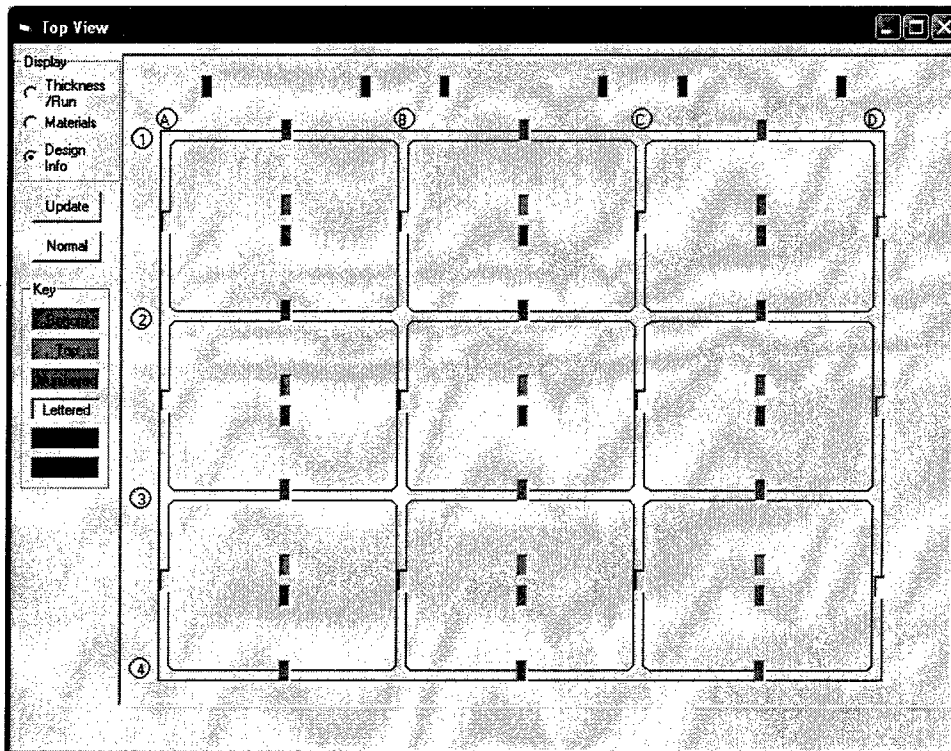

Figure A72. Request Design Info using the Top View

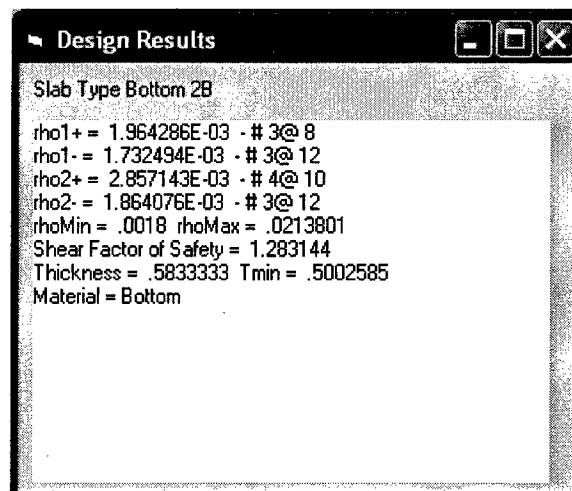

Figure A73. Design Results for center of bottom slab

## 6 Results Summary

The design calculated by the DBAS-INS program agrees well with the textbook solution that was based on the Direct Design Method. Since the load imposed in the computer program is an upward pressure, a negative moment is developed in the center of the slab instead of a positive moment in an actual floor, so the reinforcement should be reversed. The program calculates #3 @ 12 in. for the moments in the center of the slab. The floor slab required #3 @ 8.5 in. The reinforcement for negative moment regions of the floor slab (positive moments in the DBAS-INS results) is greater. Similar steel ratios were obtained by the program and the book solution. The shear results are in good agreement with the textbook design, and the 7-in. thickness was originally selected because the minimum thickness,  $T_{min}$ , was greater than 6 in. (0.5 ft).

# Appendix B

## Example Problem 2

### (Complete Section)

The Complete Section example demonstrates the methods to generate a model of a complete section of an innovative navigation structure. It will focus on procedures and capabilities that were not required for the simple model in Example Problem 1 (Appendix A). Segments 1 and 2 of the Braddock Dam project were modeled. Three different spillways are on the Segment 1 model, separated by piers. Figure B1 shows the plan view of the segment. The local NSEW coordinate system is displayed and used throughout the model. Segment 2 is two Standard Gate bays separated by piers.

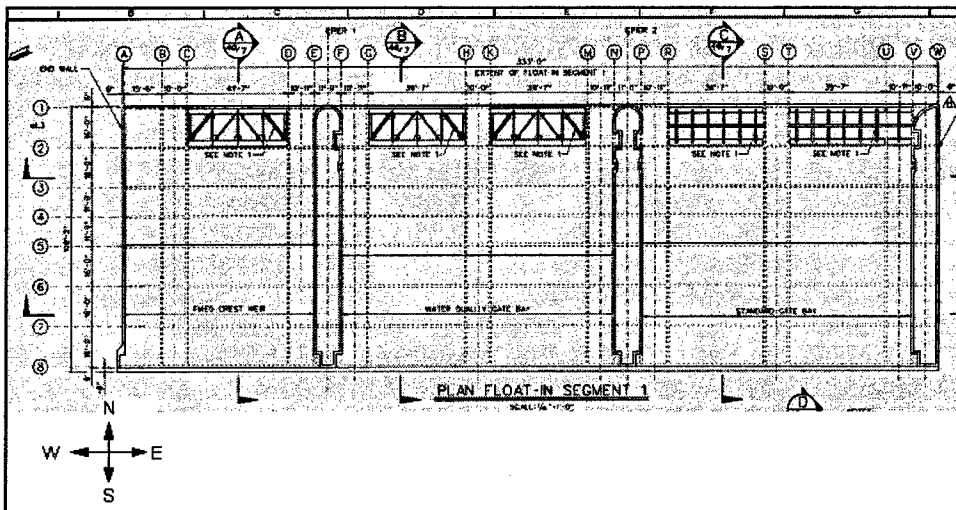

Figure B1. Braddock Segment 1

## Preprocess

The first step in modeling the structure is to input the number and locations of the diaphragm walls. These are accessed through the Preprocess menu item (Figure B2).

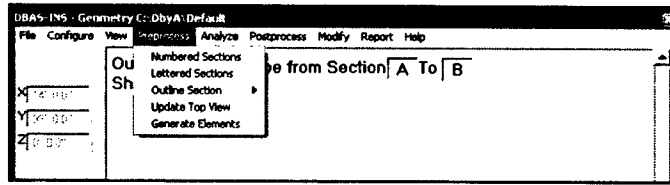

Figure B2. Preprocess menu item

There are eight numbered section lines in Segment 1, so the number of segments (Figure B3), the width of the segment (Figure B4), and the X coordinates of the section lines and wall thicknesses (Figures B5-B7) are input in response to prompts from the program. The coordinates and thicknesses can be entered in feet and inches or decimal values of feet.

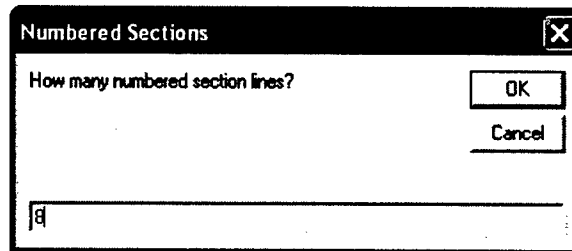

Figure B3. Input 8 numbered section lines

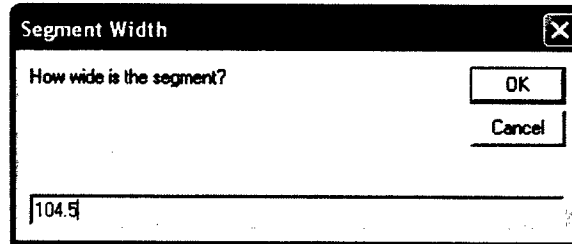

Figure B4. Input the width of the segment

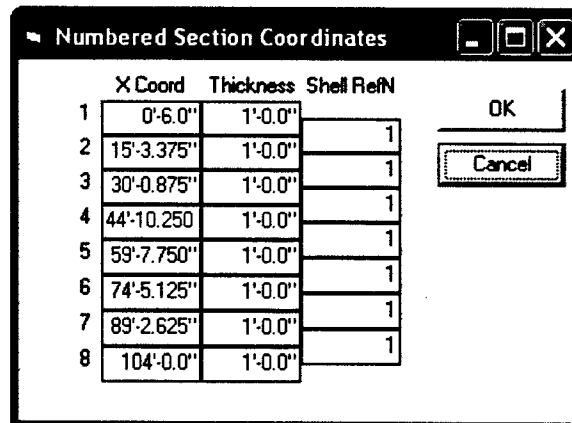

Figure B5. Default section coordinates are equally spaced over the width

	X Coord	Thickness	Shell RefN
1	0'-6.0"	1'-0.0"	1
2	16'-6.0"	1'-0.0"	1
3	32'-5	1'-0.0"	1
4	44'-10.250	1'-0.0"	1
5	59'-7.750"	1'-0.0"	1
6	74'-5.125"	1'-0.0"	1
7	89'-2.625"	1'-0.0"	1
8	104'-0.0"	1'-0.0"	1

Figure B6. Actual coordinates can be entered as feet in a decimal format

	X Coord	Thickness	Shell RefN
1	0'-6.0"	1'-0.0"	1
2	16'-6.0"	0'-10.0"	1
3	32'-6.0"	0'-10.0"	1
4	44'-3.0"	0'-10.0"	1
5	56'-0.0"	1'-0.0"	1
6	72'-0.0"	1'-0.0"	1
7	88'-0"	1'-0.0"	1
8	104'-0.0"	1'-0.0"	1

Figure B7. Wall thicknesses are revised in the Numbered Section Coordinates form

After numbered section properties are entered, the user selects Lettered Sections from the Preprocess menu item and inputs the number of section lines (Figure B8), the length of the segment (Figure B9) and additional properties of the lettered section (Figures B10-B12).

Lettered Sections

How many lettered section lines?

18

OK  
Cancel

Figure B8. Input 18 lettered section lines

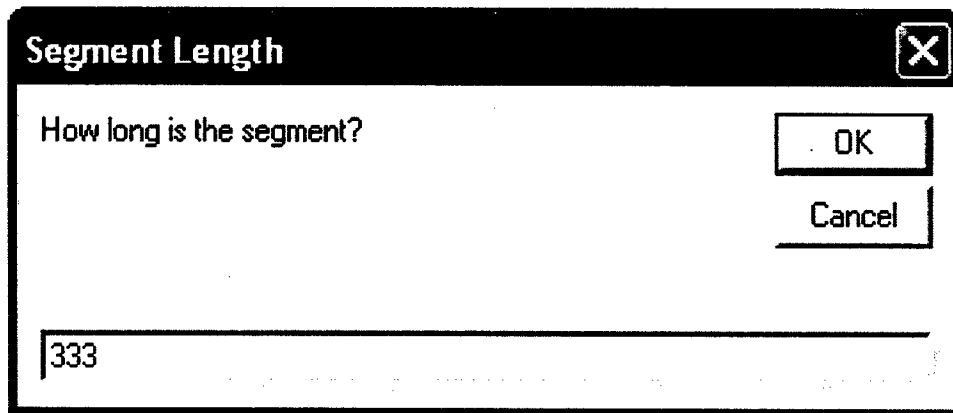

Figure B9. Input the length of the segment

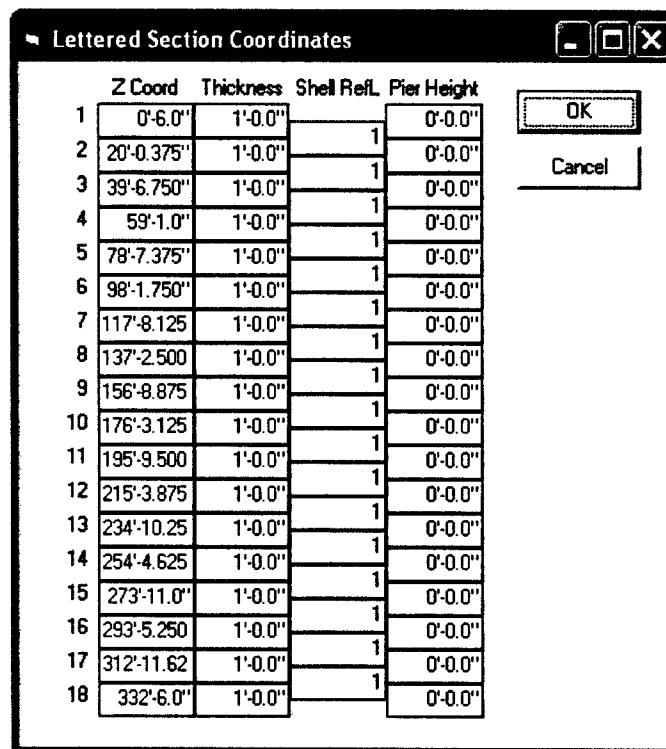

Figure B10. Default values for Z coordinate and thickness are assigned initially

The default Z coordinates are updated to reflect the actual design values as shown in Figure B11. One pier height value has been entered in the figure for the fifth section line (E). The user highlights that value and uses Windows hot-keys to Copy (Cntl-C) and Paste (Cntl-V) the value in other locations, as shown in Figure B12. A coarse shell refinement of 1 is maintained for the initial model.

**Lettered Section Coordinates**

	Z Coord	Thickness	Shell Ref.	Pier Height
1	0'-6.0"	1'-0.0"		0'-0.0"
2	16'-0.0"	1'-0.0"	1	0'-0.0"
3	26'-0.0"	1'-0.0"	1	0'-0.0"
4	67'-6.0"	1'-0.0"	1	0'-0.0"
5	78'-6.0"	1'-0.0"	1	42'-3.625"
6	89'-6.0"	1'-0.0"	1	0'-0.0"
7	100'-6.0"	1'-0.0"	1	0'-0.0"
8	140'-0.0"	1'-0.0"	1	0'-0.0"
9	150'-0.0"	1'-0.0"	1	0'-0.0"
10	189'-6.0"	1'-0.0"	1	0'-0.0"
11	200'-6.0"	1'-0.0"	1	0'-0.0"
12	211'-6.0"	1'-0.0"	1	0'-0.0"
13	222'-6.0"	1'-0.0"	1	0'-0.0"
14	262'-0.0"	1'-0.0"	1	0'-0.0"
15	272'-0.0"	1'-0.0"	1	0'-0.0"
16	311'-6.0"	1'-0.0"	1	0'-0.0"
17	322'-6.0"	1'-0.0"	1	0'-0.0"
18	332'-6.0"	1'-0.0"	1	0'-0.0"

OK  
Cancel

Figure B11. Enter a non-zero pier height at pier wall section lines

**Lettered Section Coordinates**

	Z Coord	Thickness	Shell Ref.	Pier Height
1	0'-6.0"	1'-0.0"		0'-0.0"
2	16'-0.0"	1'-0.0"	1	0'-0.0"
3	26'-0.0"	1'-0.0"	1	0'-0.0"
4	67'-6.0"	1'-0.0"	1	0'-0.0"
5	78'-6.0"	1'-0.0"	1	42'-3.625"
6	89'-6.0"	1'-0.0"	1	42'-3.625"
7	100'-6.0"	1'-0.0"	1	0'-0.0"
8	140'-0.0"	1'-0.0"	1	0'-0.0"
9	150'-0.0"	1'-0.0"	1	0'-0.0"
10	189'-6.0"	1'-0.0"	1	0'-0.0"
11	200'-6.0"	1'-0.0"	1	42'-3.625"
12	211'-6.0"	1'-0.0"	1	42'-3.625"
13	222'-6.0"	1'-0.0"	1	0'-0.0"
14	262'-0.0"	1'-0.0"	1	0'-0.0"
15	272'-0.0"	1'-0.0"	1	0'-0.0"
16	311'-6.0"	1'-0.0"	1	0'-0.0"
17	322'-6.0"	1'-0.0"	1	42'-3.625"
18	332'-6.0"	1'-0.0"	1	42'-3.625"

OK  
Cancel

Figure B12. Pier height is pasted in all appropriate boxes

After laying out the diaphragms, the user adds spillway section outlines to the model. An appropriate template is selected from the Preprocess | Outline Section menu item as shown in Figure B13. The sections should be generated as they occur from left to right (West to East) in the model.

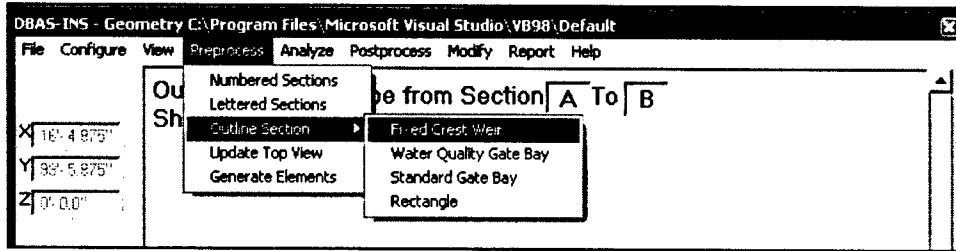

Figure B13. Preprocess | Outline Section menu item

The default layout for the Fixed Crest Weir appears when selected (Figure B14). The default values reflect the Braddock design. Modifications to the parameters are input in the text boxes, and the Update View (UV) button is clicked to show the changes to the model.

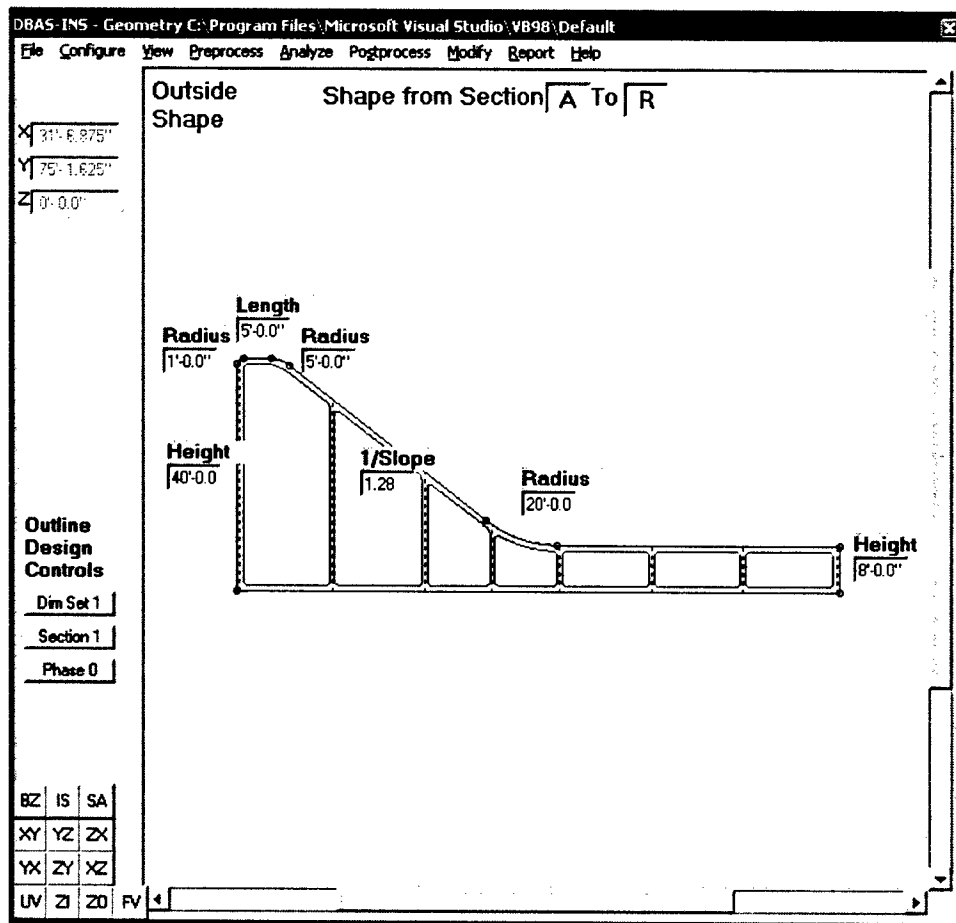

Figure B14. Default fixed crest weir outline

Clicking the Dim Set 1 button displays Dimension Set 2, which controls the slab thicknesses (Figure B15). Three diaphragm walls are shown as 10 in. thick based on the input provided in Figure B7 above. Any of these values can be changed. The view can then be updated to reflect the changes in the plot. The section of the model with this spillway shape is input by changing the section letters in the Shape from Section text boxes at the top of the sketch. Figure B15 shows that this shape is used from Sections A through F.

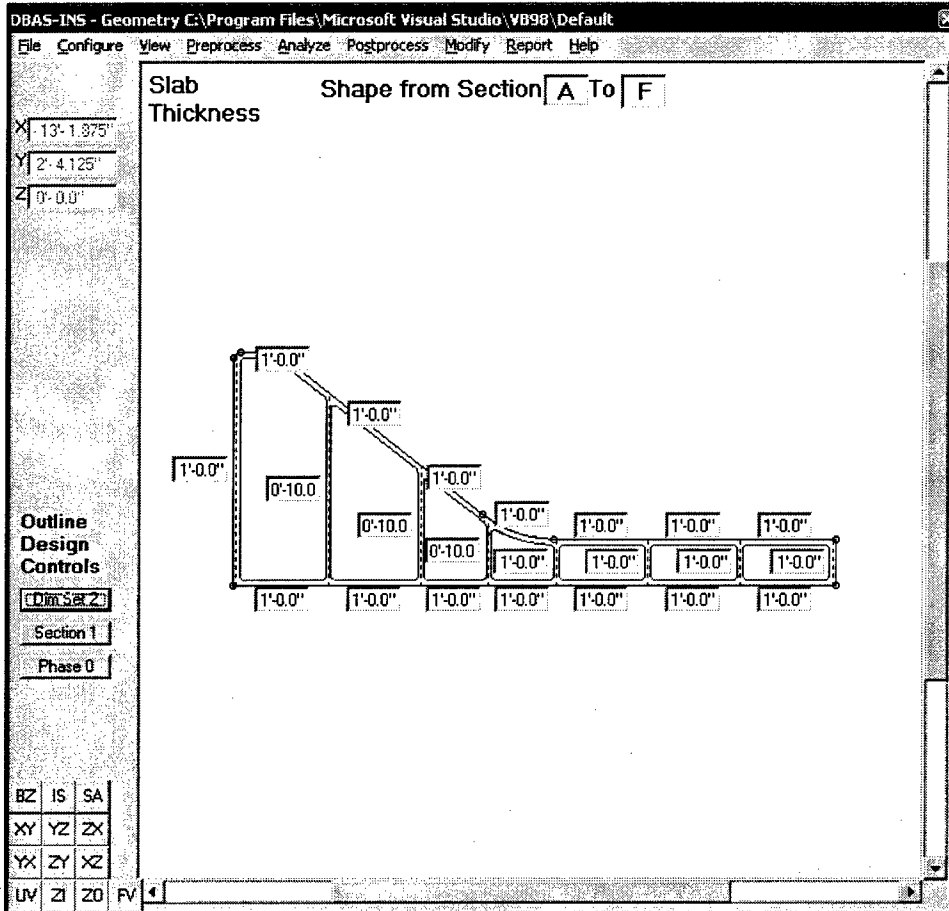
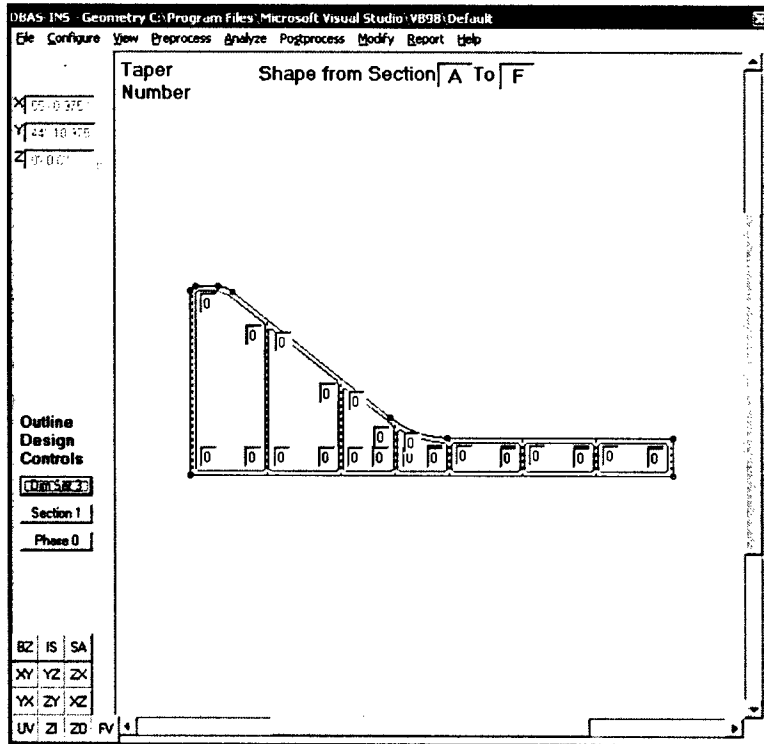
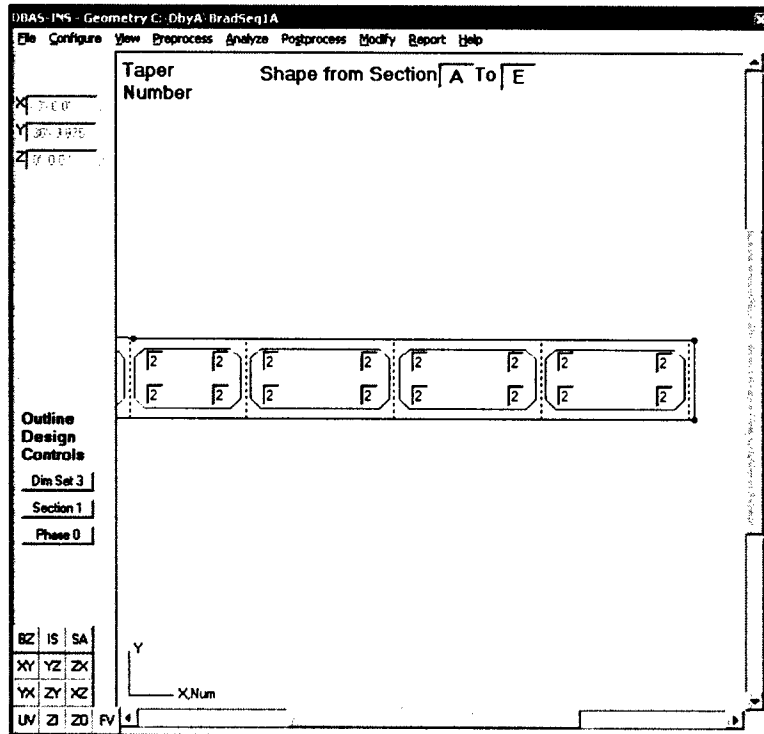

Figure B15. Dimension Set 2 - thicknesses

Dimension Set 3 is accessed by clicking the Dim Set 2 button (Figure B16). Clicking Dim Set 3 returns the plot to Dimension Set 1. The default Taper Number of 0 is displayed at all joints. The Zoom commands can be used to clearly display the taper number text boxes in crowded regions of the model, as shown in Figure B16b. This is a taper with a Run of 12 in. and a Rise of 18 in., as shown in Figure B17. Refer to the main text of the User Manual (Section 5.3.2.3) for a complete definition of Run and Rise as they are used in DBAS-INS.



a. Tapers



b. Zoom on the downstream end of the spillway

Figure B16. Dimension Set 3 (Continued)

The user will normally want to add tapers with different properties to the model. The default works well at 90-deg joints, but other configurations may be desired on sloped faces. New taper numbers are defined in the Taper Types form (Figure B17), which appears when Dim Set 3 is active.

Number	Run(in.)	Rise(in.)
0	12	18
1		

**Add**

Figure B17. Taper Types form

Figure B18 shows the tapers used in this model. The user can add new tapers at any time by entering the Run and Rise and clicking Add. The new tapers have been input in Figure B19 and the view updated to reflect the changes.

Number	Run(in.)	Rise(in.)
0	12	18
1	12	24
2	18	24
3	30	24
4		

**Add**

Figure B18. Four taper types are defined

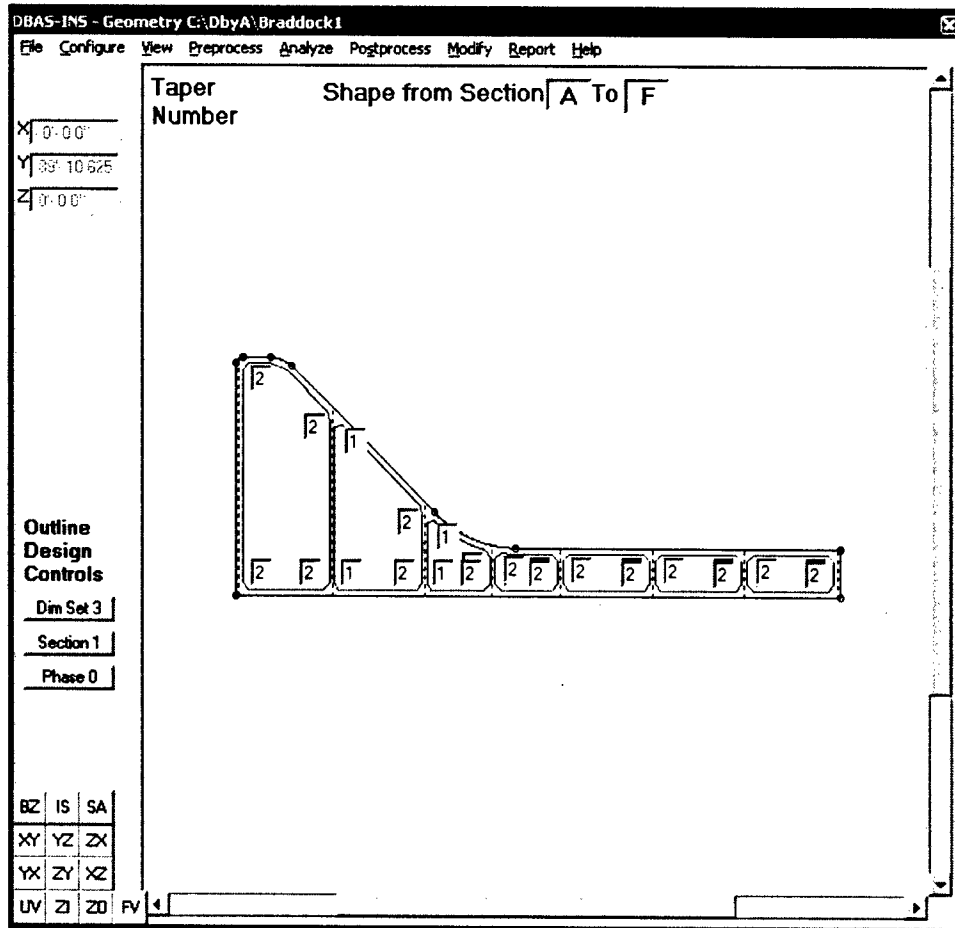

Figure B19. Assign new taper numbers

The spillway shape in the middle of the segment is a Water Quality Gate Bay. This shape is added by selecting the appropriate template under the Preprocess | Outline Section menu item as shown in Figure B20.

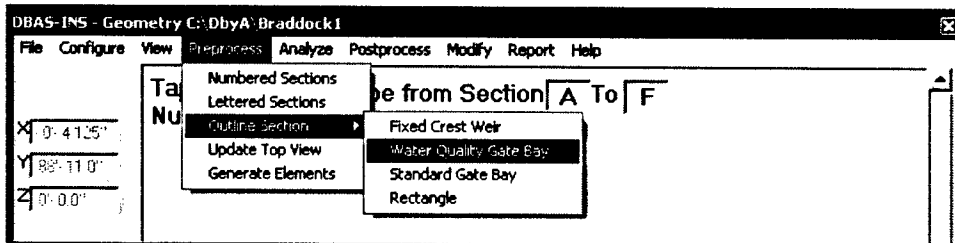

Figure B20. Open the Water Quality Gate Bay template

Figure B21 shows the default shape. The user has defined the location of this spillway from section lines F through L. The Thickness and Taper Numbers are displayed in Figures B22 and B23.

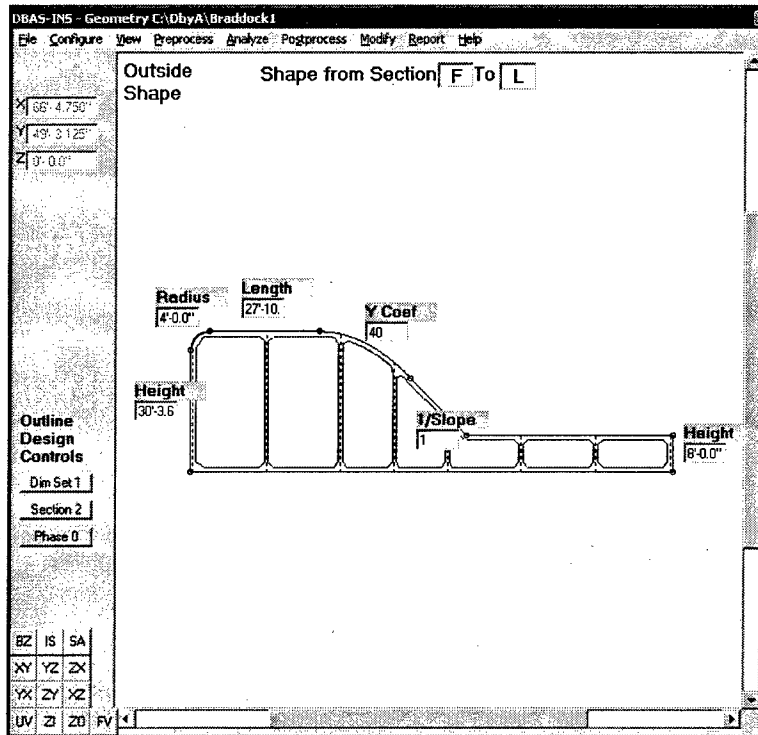

Figure B21. Water Quality Gate Bay template

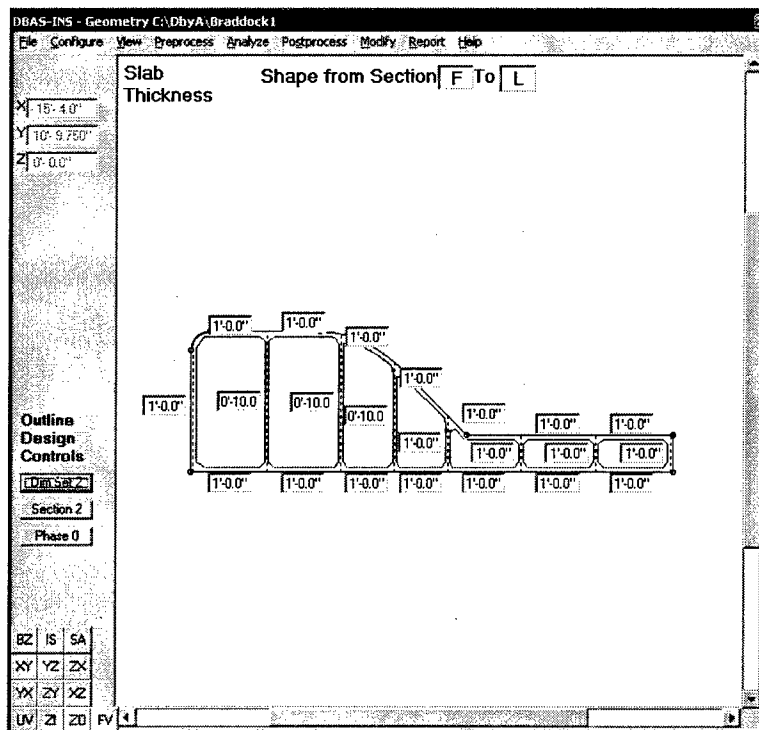

Figure B22. Water Quality Gate Bay slab thicknesses

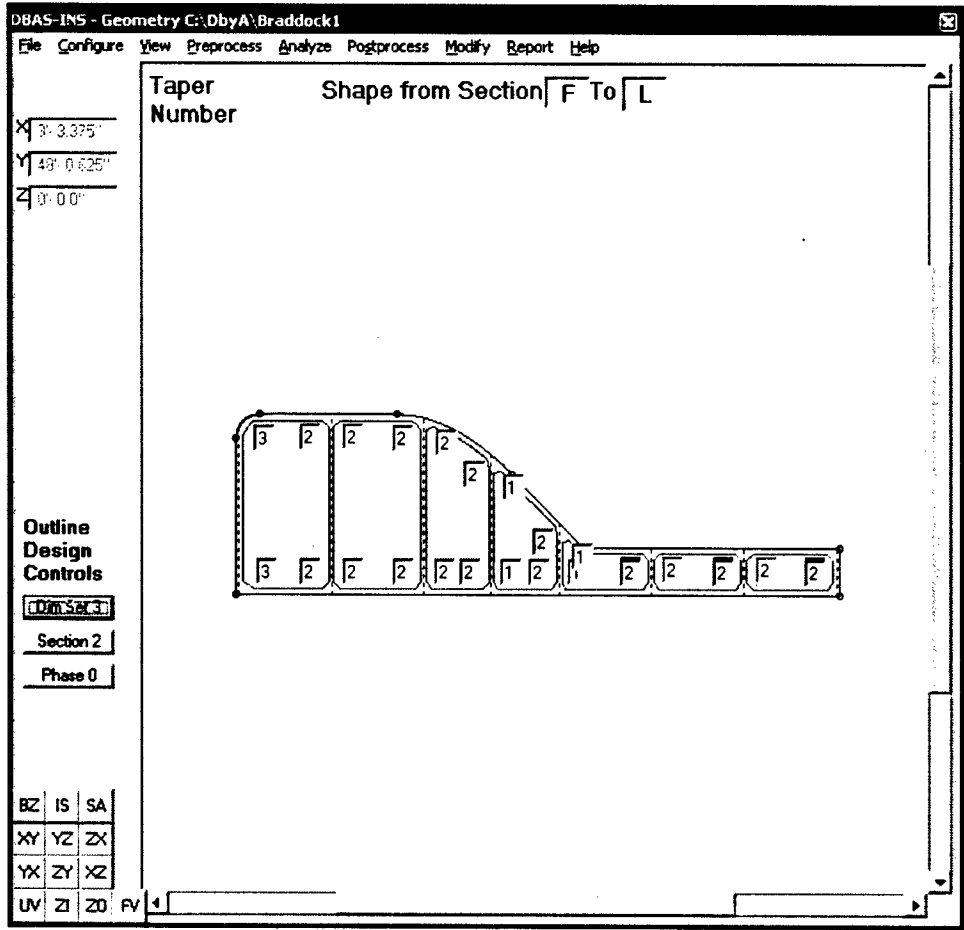

Figure B23. Water Quality Gate Bay taper numbers

The final spillway is a Standard Gate Bay. This template is opened as shown in Figure B24. This shape forms the remainder of the segment from section lines L through R (Figure B25). Thicknesses and tapers are shown in Figures B26 and B27.

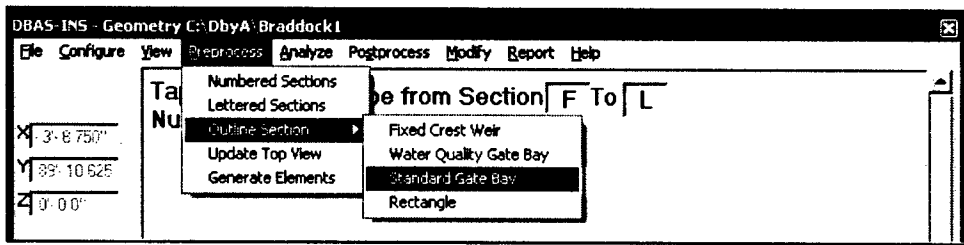

Figure B24. Create Standard Gate Bay template



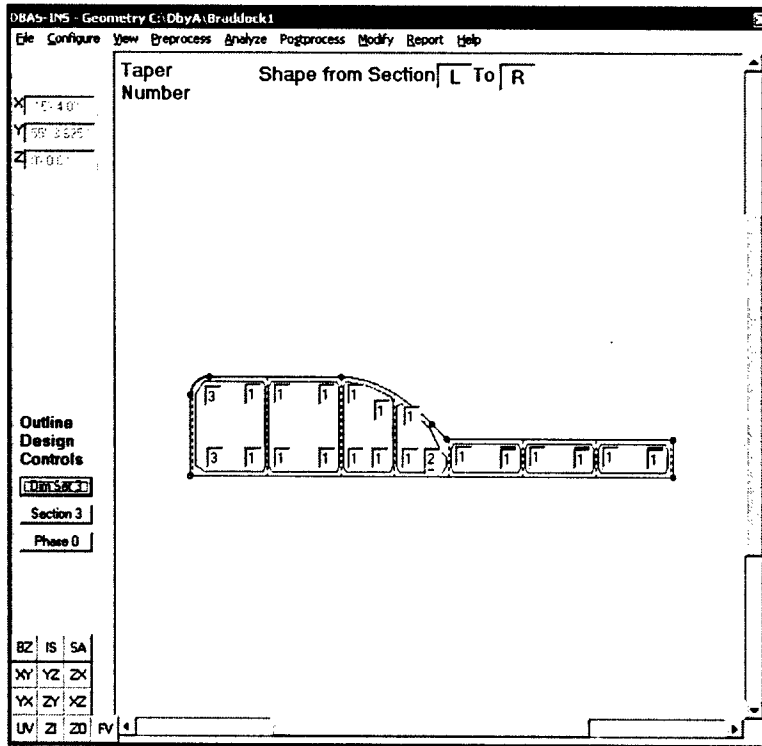

Figure B27. Standard Gate Bay taper numbers

After laying out the spillways for the model, the user can plot the top view (see Figure B2) to check the inputs and modify slab thicknesses and some tapers. Figure B28 is the default top view showing the entire model. The user can plot a smaller part of the model by changing the Extents in the Plot Control form (Figure B29). Figure B30 is a plot of the northwest corner of the model.

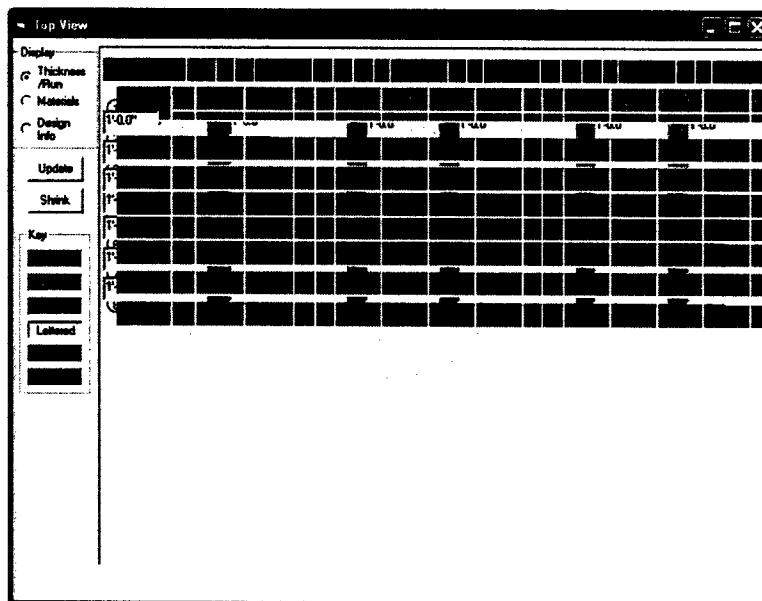

Figure B28. Top View plot

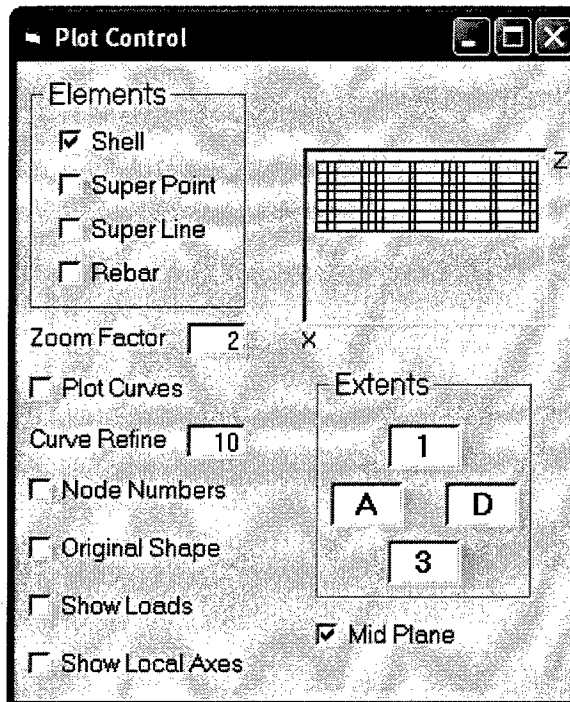

Figure B29. Change the Extents in the Plot Control form to display part of the segment

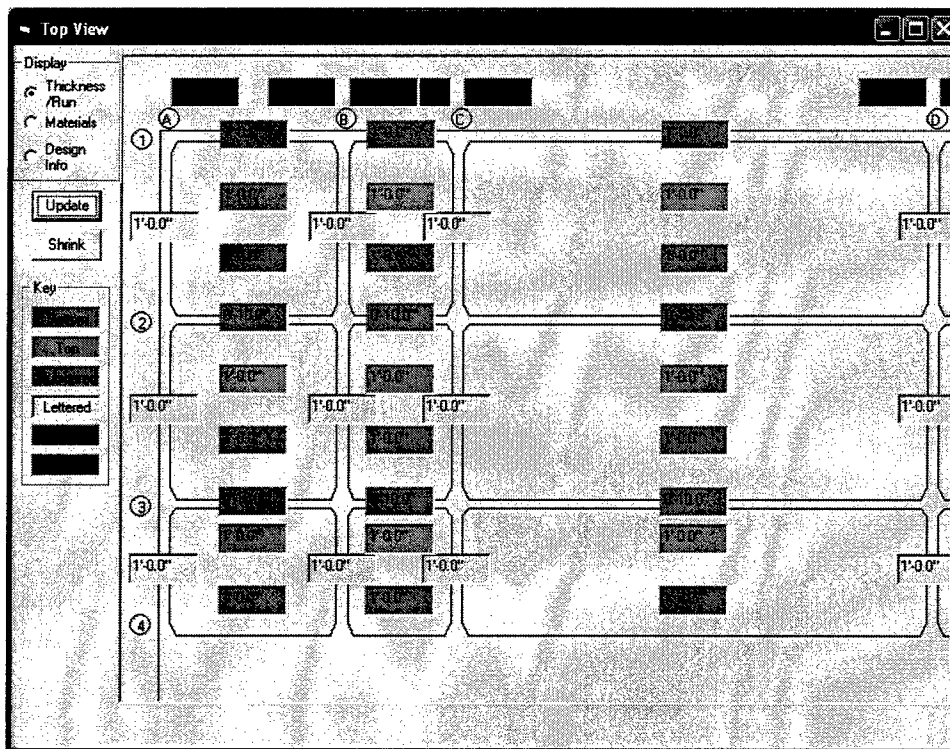

Figure B30. Click Update to display part of the model as defined in Figure B29

The user requests a Materials Display in the upper left-hand corner of the Top View form. Figure B31 shows the default materials assigned to the model.

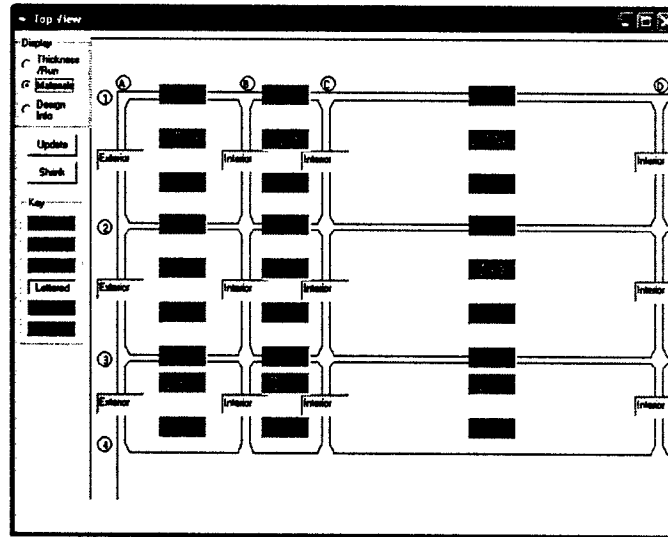

Figure B31. Default material properties

The final step in the Preprocess phase (Figure B2) is to Generate Elements. Figure B32 is a plot of the shell elements in the Braddock Dam, Segment 1, model.

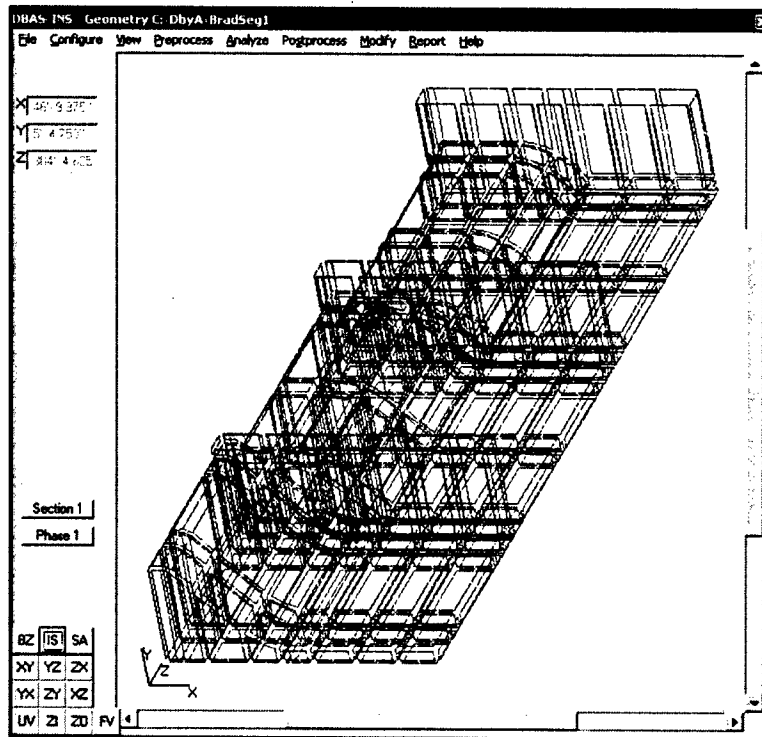

Figure B32. Shell elements in the finite element model

## Analyze

Additional model parameters are input in the Analyze Phase. These include material properties, boundary condition, and load cases. These options are accessed through the Analyze menu item (Figure B33).

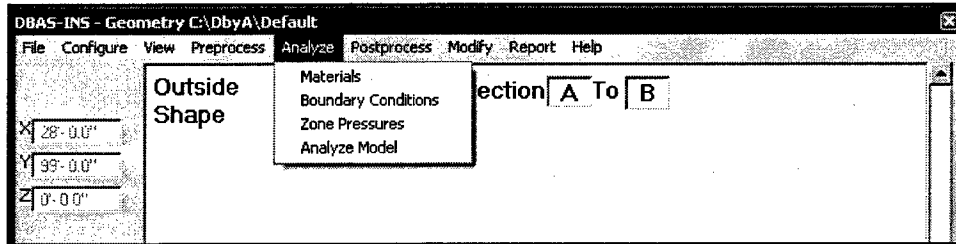

Figure B33. Analyze menu item

Six default material names are provided, as shown in Figure B34. These properties will be automatically assigned to appropriate elements in the model. New material names can be added using the Materials form, and the material assignments can be changed in the Top View (Figure B31).

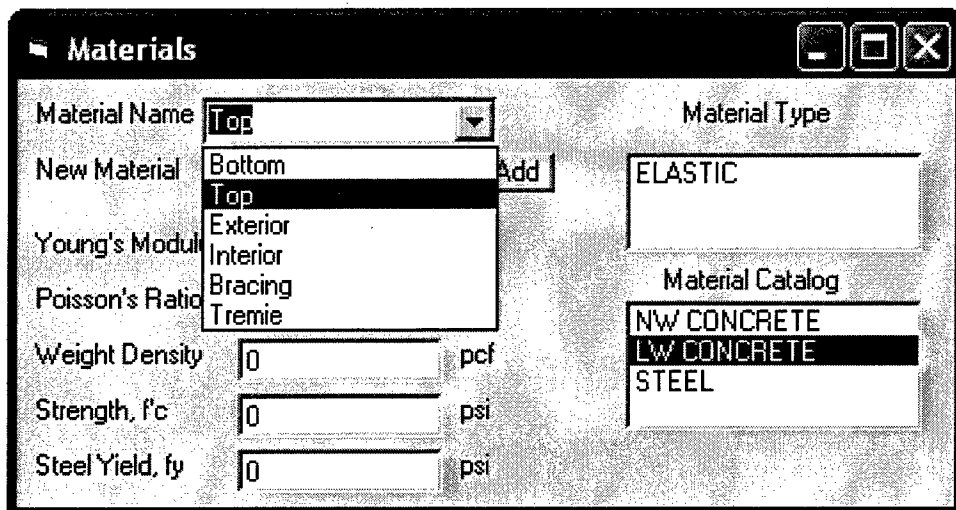

Figure B34. Material form with six default material names

Material properties can be added directly in the form, or a material in the Material Catalog can be selected to create properties for the material listed in the Material Name box (Figure B35). These properties can be modified as required. Changes are made automatically to the model when a value is changed. Material with properties shown in Figures B35-B37 was used in the Braddock Dam model.

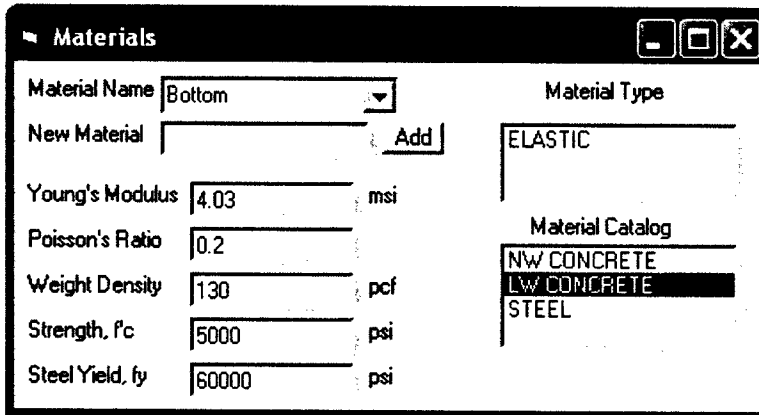

Figure B35. Select lightweight concrete from the Material Catalog

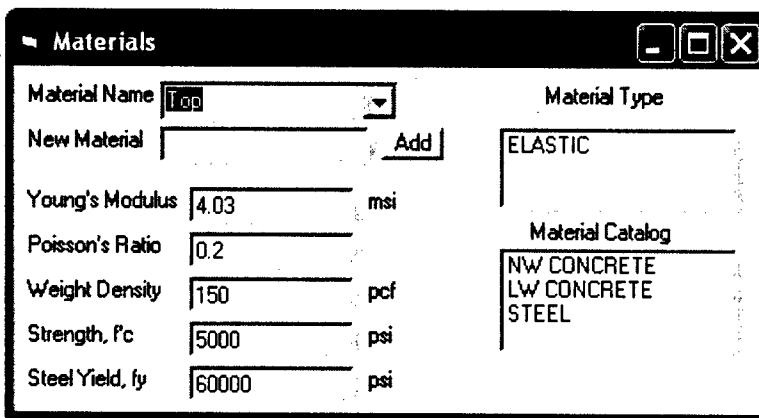

Figure B36. Concrete properties for top slabs

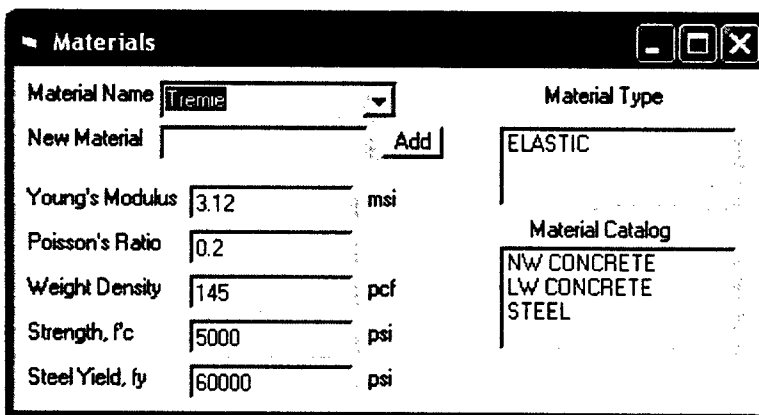

Figure B37. Properties for tremie concrete

Boundary conditions are selected in the Boundary Conditions form (Figure B38).

The screenshot shows a window titled "Boundary Conditions" with standard window controls (minimize, maximize, close) in the top right. Below the title bar is a section labeled "Select one or more" containing four checkboxes: "Continuous Elastic Foundation" (checked), "Floating", "Set Down Shafts", and "Drilled Piers". To the right of these checkboxes are two buttons: "Define SDS" and "Define DPS". Below this section is a "Foundation Stiffness" field with a value of "100" and the unit "ksf". Underneath is a checked checkbox for "Body Force". At the bottom, there are four input fields: "Float Depth" (0.0), "Dead Load Factor" (1.4), and "Live Load Factor" (1.7).

Figure B38. Boundary Conditions form

When the Floating condition is selected (Figure B39), the program will calculate the approximate float depth based on unfactored loads. Once the pressure distribution is established, body forces are multiplied by the dead load factor, and pressures are multiplied by the live load factor to complete the analysis.

This screenshot is identical in layout to Figure B38, but the "Floating" checkbox is now checked, and the "Continuous Elastic Foundation" checkbox is unchecked. The "Define SDS" and "Define DPS" buttons are now disabled (grayed out). The "Foundation Stiffness" field remains at "100 ksf", "Body Force" is checked, and the "Float Depth", "Dead Load Factor", and "Live Load Factor" fields remain at "0.0", "1.4", and "1.7" respectively.

Figure B39. Select the Floating boundary condition

Loads from water or tremie concrete in individual cells in the structure are defined in various load cases for the model. The Fluid Depths form shown in Figure B40 is opened by selecting Zone Pressures under the Analyze menu item (Figure B33). Negative values indicate that the fluid is tremie concrete. The -6 value entered in Row 2, Column L in Figure B40 indicates that there is 6 ft of tremie concrete in the cell bounded by section lines 2, L, 3, and M. When the tremie is fully cured, this input reflects dead load in the cell.

Fluid Depths (ft.)

	J	K	L	M	N
1	-6	0	-6	0	
2	-6	-6	-6	0	
3	0	0	0	0	
4	0	0	0	0	
6	-6	0	0	0	
8	-6	-6	0	0	
7	-6	0	0	0	

OK  
Cancel  
Accept  
Load Case  
LC2  
Nodal Forces

Figure B40. Fluid Depths form

Positive 1.5 is input in cell 1C (Figure B41) to account for water used to ballast the structure.

Fluid Depths (ft.)

	B	C	D	E	F
Upstream	0	0	0	0	0
1	-6	1.5	-6	0	
2	-6	0	-6	-6	
3	0	0	0	0	
4	0	0	0	0	
6	-6	0	-6	0	
8	-6	0	-6	-6	

OK  
Cancel  
Accept  
Load Case  
LC2  
Nodal Forces

Figure B41. Water is added to cell 1C for ballast

Figure B42 reflects the input for Load Case LC2 defined above. Blue rectangles indicate the water depth in the cell. Gray designates tremie concrete.

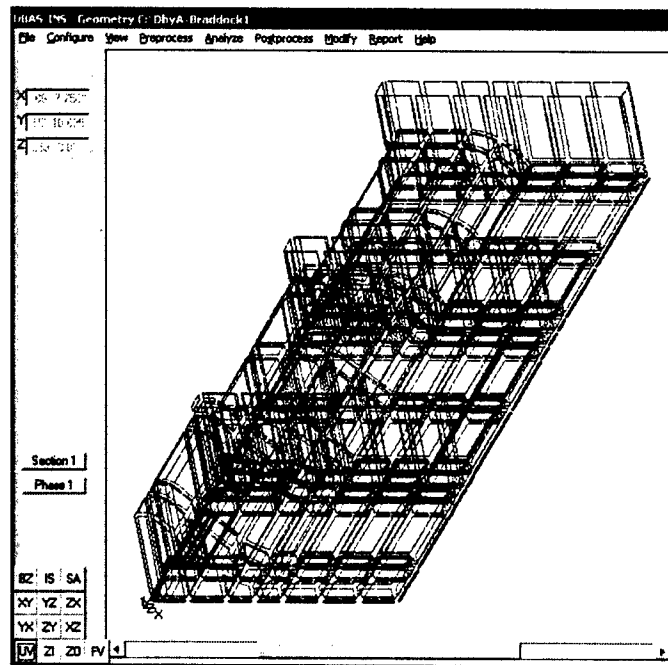

Figure B42. Load Case 2 fluid levels

A boundary condition can be defined when the structure is resting on a limited number of drilled piers designated as Set Down Shafts (Figure B43). The locations of the shafts are defined by clicking the Define SDS button on the Set Down Shaft Locations form shown in Figure B44. An X is placed in a box to designate that a set-down shaft is located in the cell on the southeast side of the intersection of the designated section lines. The user has just input a shaft under the cell bounded by section lines 6, K, 7, and L.

**Boundary Conditions**

Select one or more

Continuous Elastic Foundation

Floating

Set Down Shafts

Drilled Piers

Define SDS

Define DPS

Foundation Stiffness  ksf

Body Force

Float Depth

Dead Load Factor  Live Load Factor

Figure B43. Select Set Down Shafts boundary condition

**Set Down Shaft Locations**

	H	I	J	K	L
1					
2				X	
3					
4					
5					
6					X
7					

OK

Cancel

Figure B44. Define Set Down Shafts

A similar input form is available to define other drilled piers used in the foundation for the segment (Figures B45 and B46). Lateral stiffness values are input for the piers in the appropriate cell of the Drilled Pier Stiffness form.

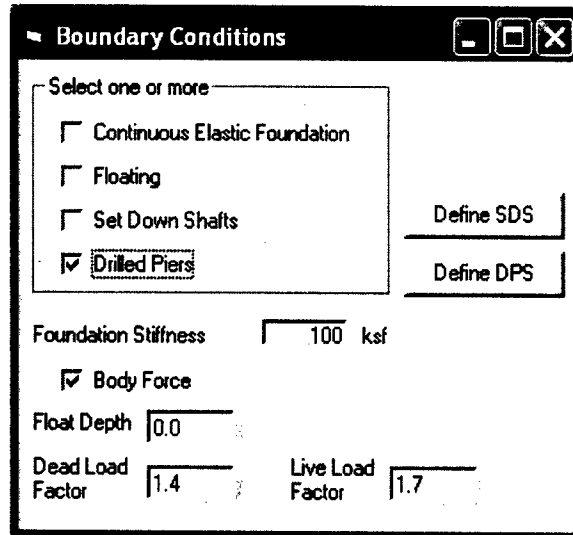

Figure B45. Select Drilled Pier boundary condition

Drilled Pier Stiffness (lb/in)

	C	D	E	F	G
1	0	-978000	0	-978000	
2	0	-978000	0	-978000	
3	0	0	0	0	
4	0	0	0	0	
5	0	-978000	0	-978000	
6	0	-978000	0	-978000	
7	0	-978000	0	-978000	

OK  
Cancel

Figure B46. Enter lateral stiffness values in the appropriate cells

The final step in the Analyze phase is to Analyze Model (Figure B33). Analysis of large models requires extensive computing time. Upon completion, a deflected shape plot of the model is generated and displayed. Figure B47 is the deflected shape plot of the Segment 2 model supported by the set-down shafts under the piers viewed from the downstream side. Figure B48 adds the superelements to the plot. The overall structure deflects as a beam supported at three points, but the deflection of individual slabs under their self weight is also evident. Buoyancy forces were not included in this example.

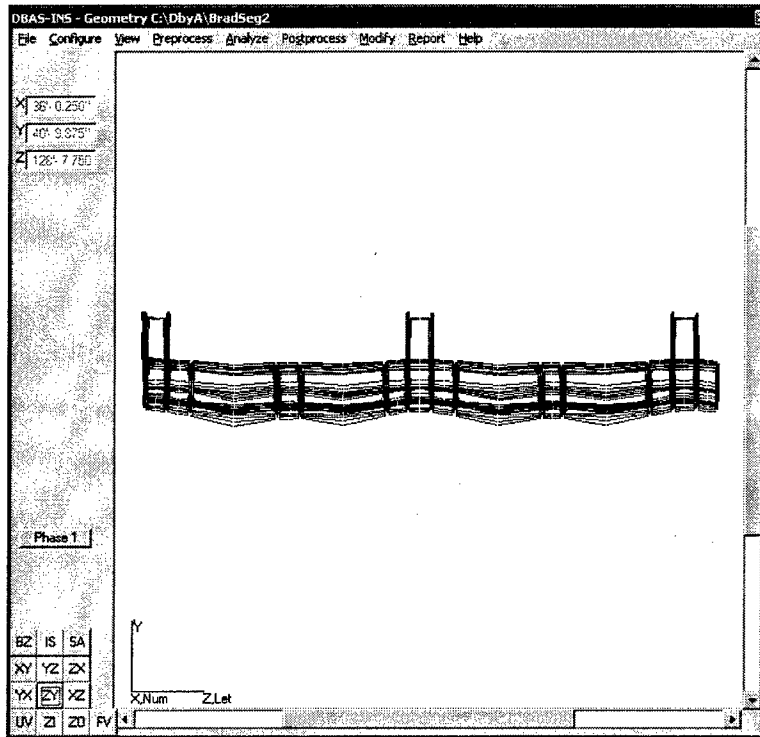

Figure B47. Segment 2 supported on set-down shafts

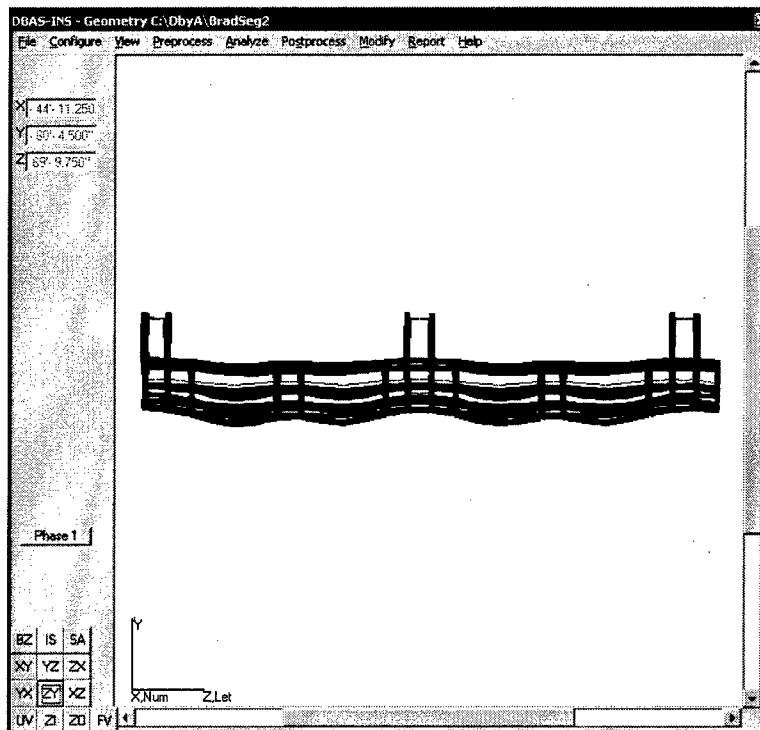

Figure B48. Deflected shape with superelements plotted

The shear forces in the bottom slabs are plotted in Figure B49. Shear is highest near the set-down shafts, which are labeled in the figure.

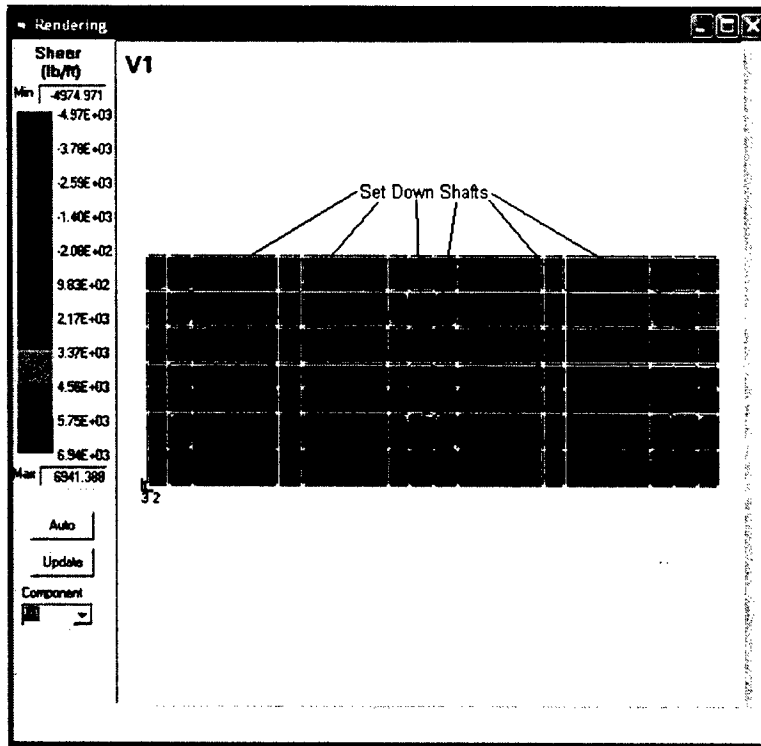

Figure B49. Shear in bottom slabs

Figure B50 shows thrust values on the external shells in the model. The local axes (1,2) are superimposed on each slab to indicate the direction of T1.

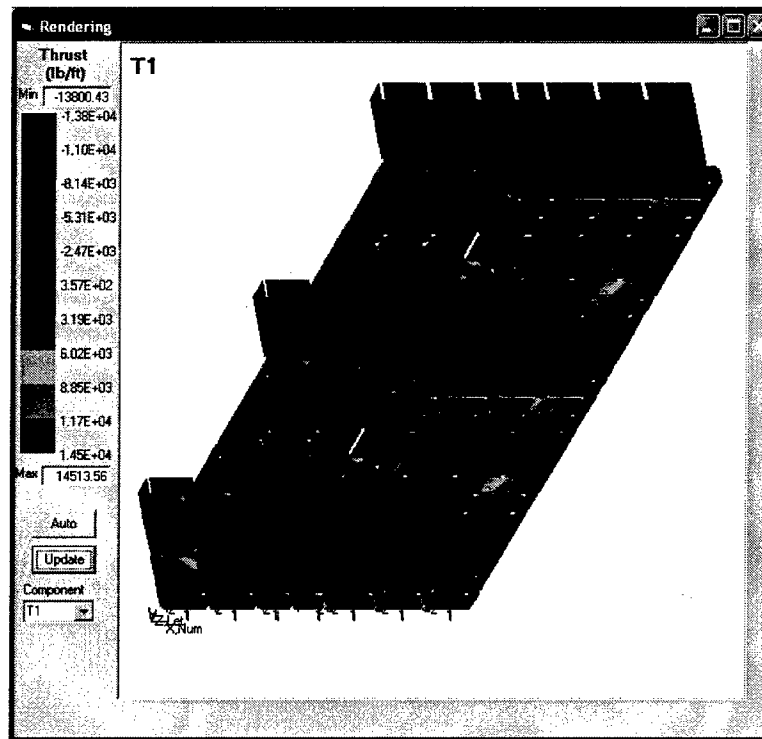

Figure B50. Thrust on Segment 2

Individual slab designs can be reviewed from the Top View (Preprocess | Update Top View). With the Design/Info button checked, the user clicks in the appropriate text box (Figure B51) to display the results in the Design Results box (Figure B52).

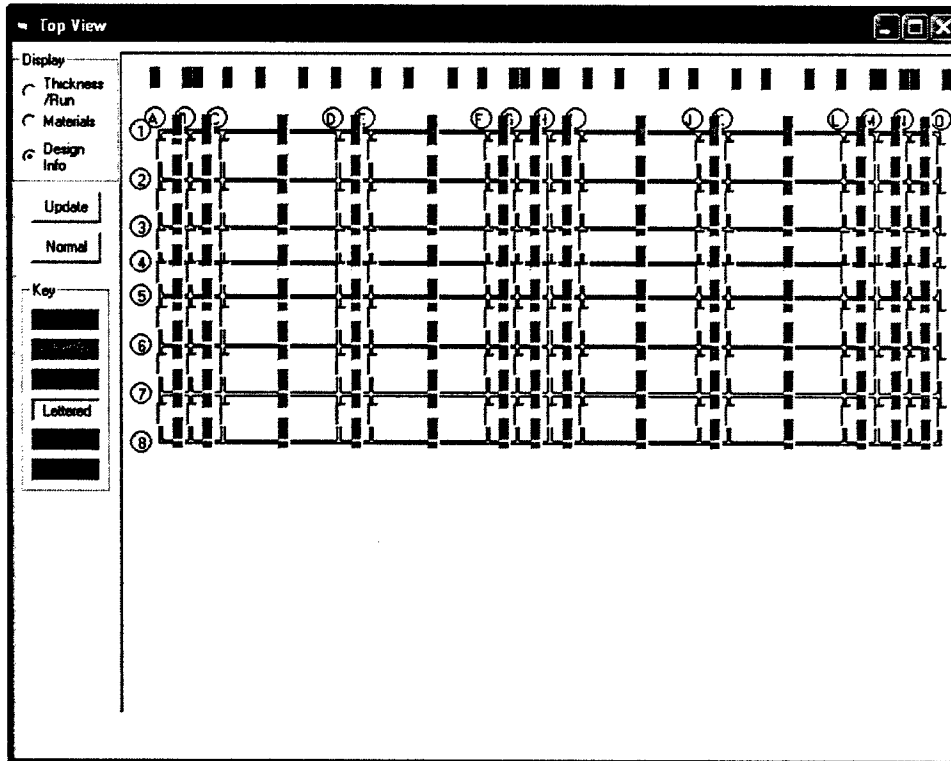

Figure B51. Request Design Information in the top view

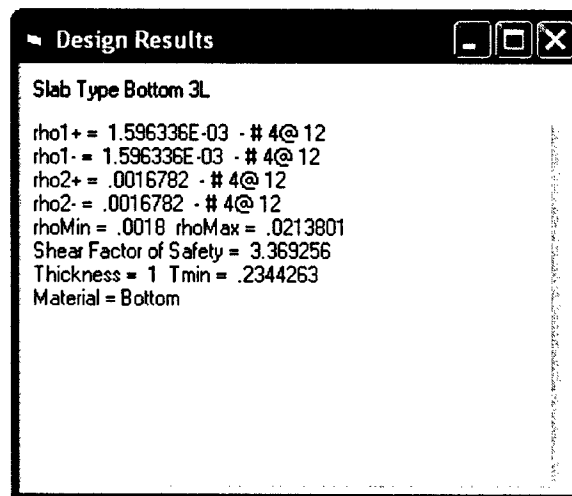

Figure B52. Standard Design Results report

In Figure B53, the Extents are changed to display part of the model. Figure B54 is a plot of thrust forces with the three west-most rows of cells removed. This allows the user to easily view results on internal slabs.

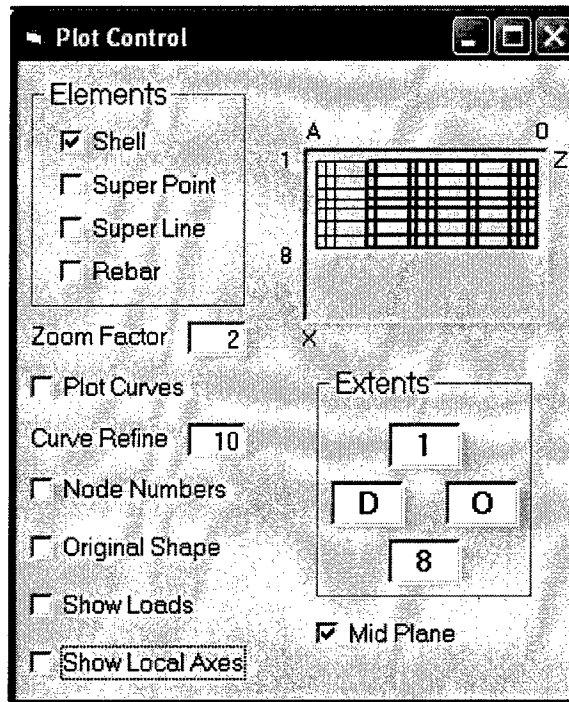

Figure B53. Set Extents to view a partial model

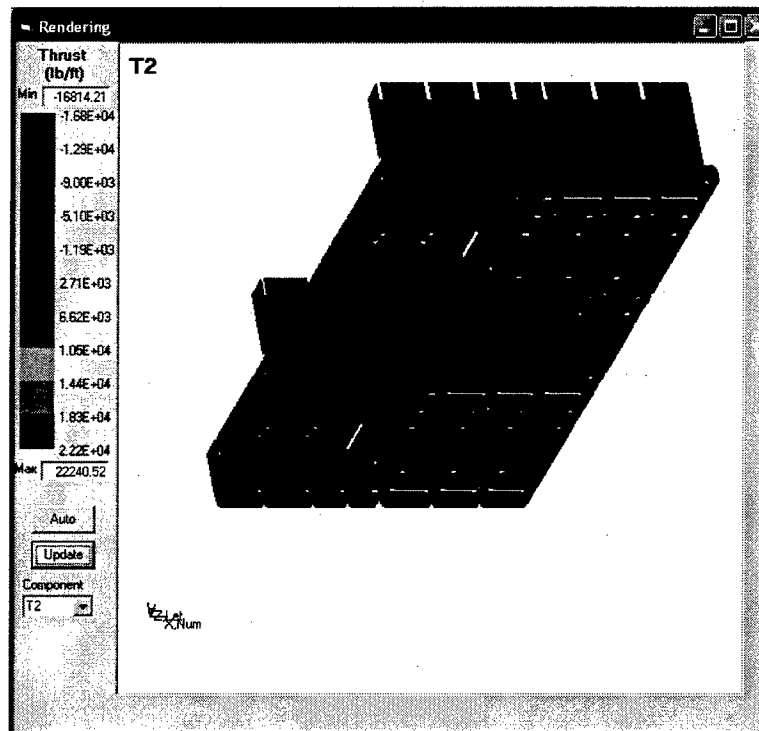

Figure B54. Plot of Segment 2 with some cells removed

The following results are from the Segment 1 model. One cell is filled with water to observe the results of an analysis with a high differential pressure between adjacent cells. Figure B55 shows that 20 ft of water is placed in Cell 2B,

which is surrounded by section lines 2, B, 3, and C. Figure B56 is a bottom view showing the magnified deformation of the interior diaphragm walls when the cell is filled.

**Fluid Depths (ft.)**

	A	B	C	D	E
1	0	0	0	0	0
2	0	20	0	0	0
3	0	0	0	0	0
4	0	0	0	0	0
5	0	0	0	0	0
6	0	0	0	0	0
7	0	0	0	0	0

OK  
Cancel  
Accept  
**Load Case**  
LC1  
Nodal Forces

Figure B55. Water is placed in a cell in Load Case 1

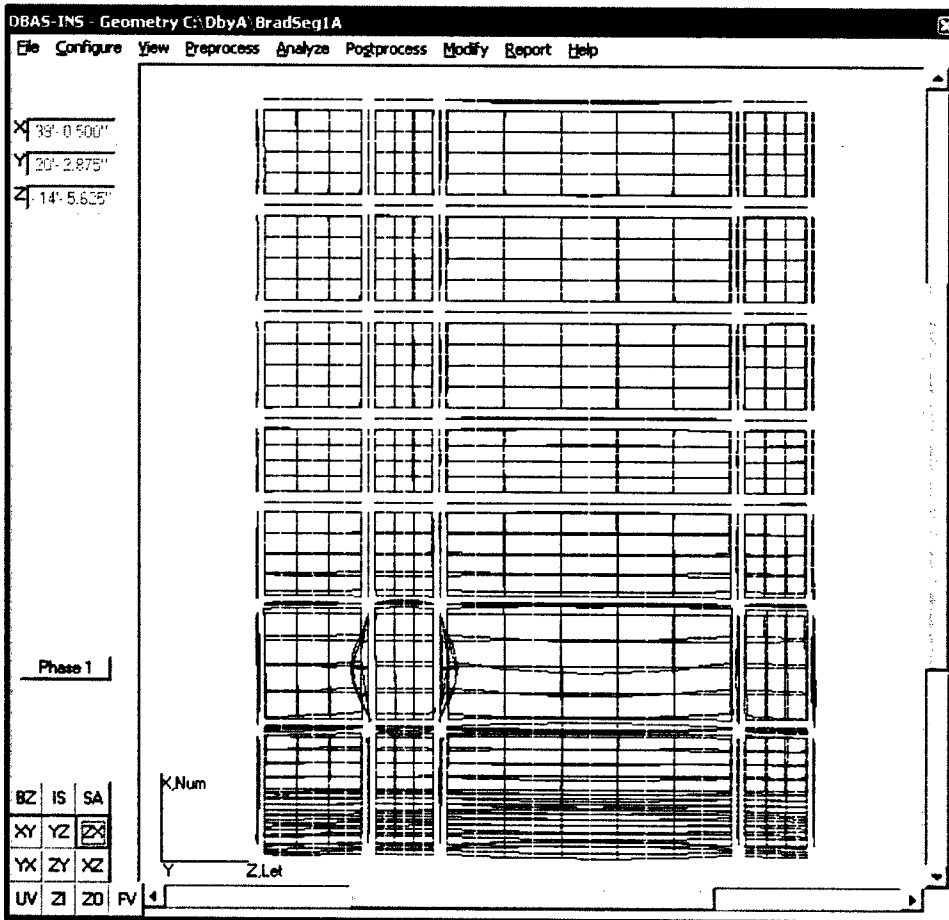

Figure B56. Deformed shape plot

The calculated Float Depth of 9.3 ft is displayed on the Boundary Conditions form shown in Figure B57.

Figure B57. Boundary Conditions form displays calculated Float Depth

Moment results and the critical shear component for the bottom slab are shown in Figures B58-B60. These moments are based on factored loads.

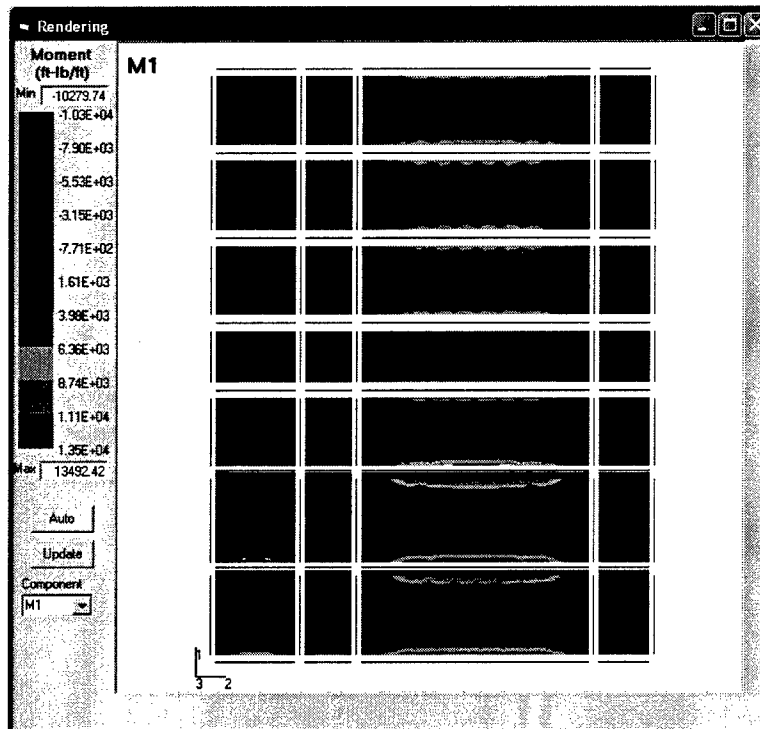

Figure B58. Moments on bottom slab – direction of flow

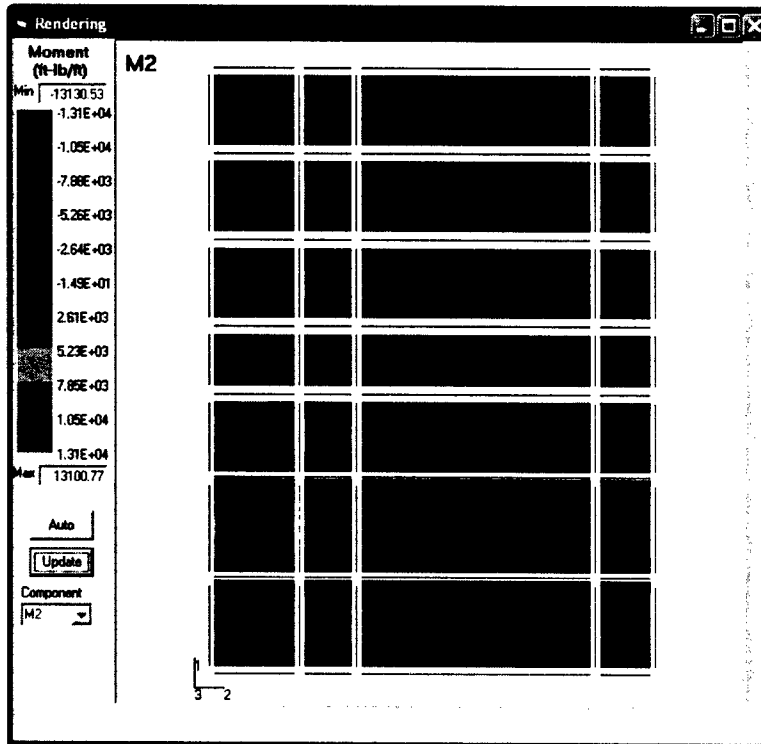

Figure B59. Moments in bottom slab – transverse to flow

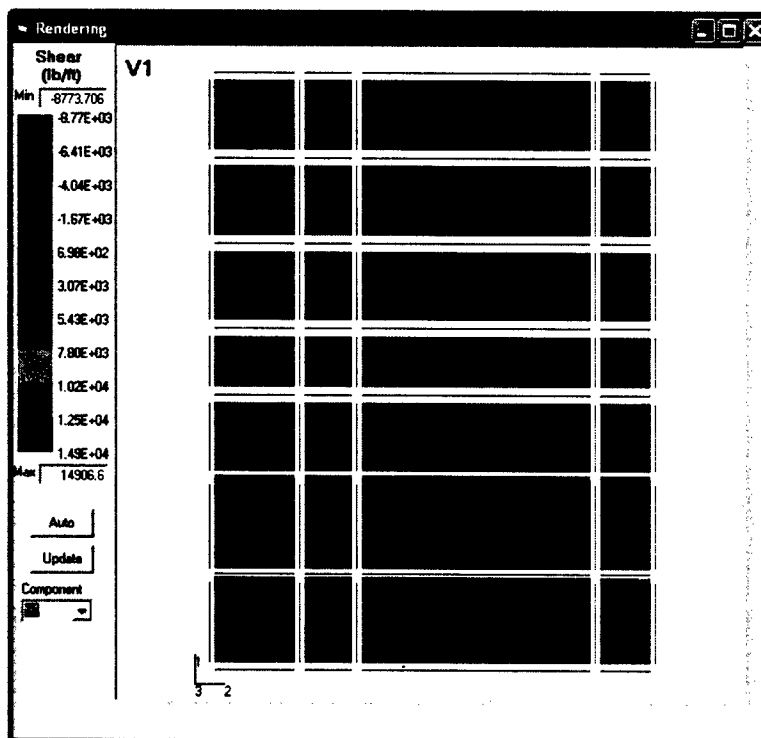

Figure B60. Critical shear in bottom slab

The rendering in Figure B61 shows moment values on the external faces of the model. The Extents are modified on the Plot Control form (Figure B62) to

display an internal diaphragm wall that is exposed to the fluid pressure in the full cell. The moments in slabs along the B section line are shown in Figure B63.

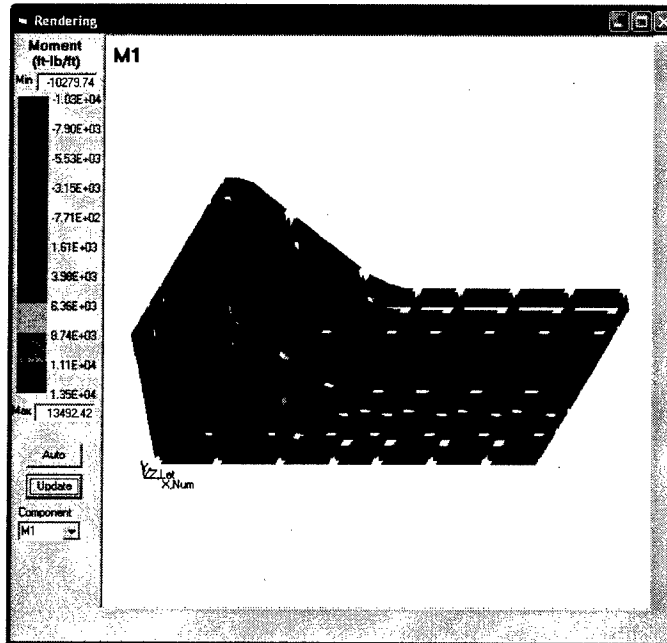

Figure B61. Moments in slabs

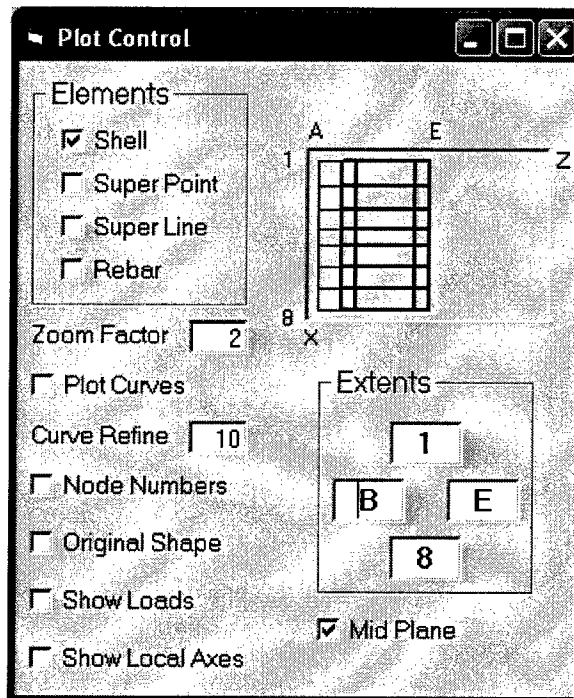

Figure B62. Adjust Extents to expose slabs of interest

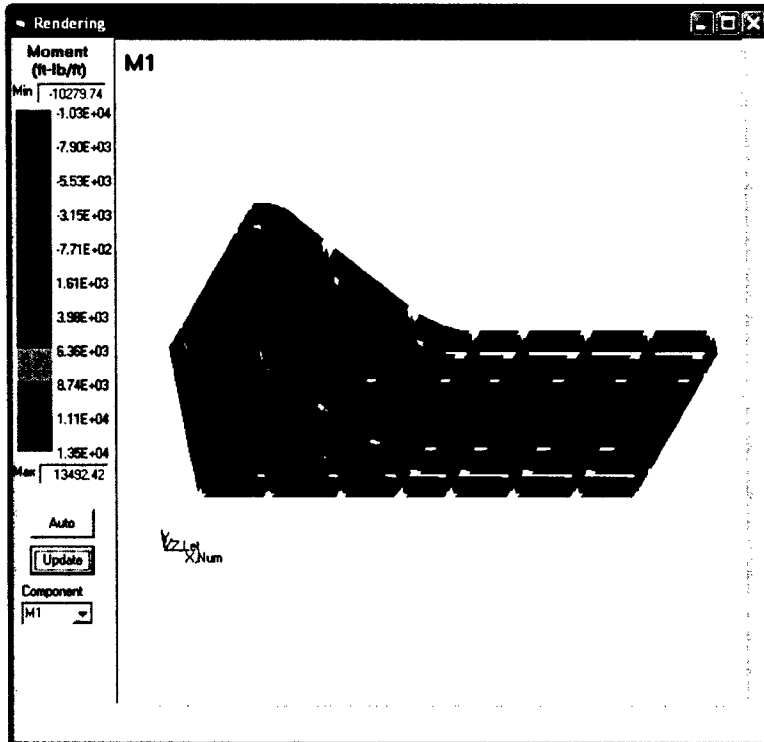

Figure B63. Moments with row of cells removed from the plot

The Top View is used to review design results. The designs for the three slabs highlighted in Figure B64 are displayed in Figures B65, B66, and B67. Figure B68 is a plot of the shear to review the Letter 3B. The design results indicate that the shear strength is inadequate.

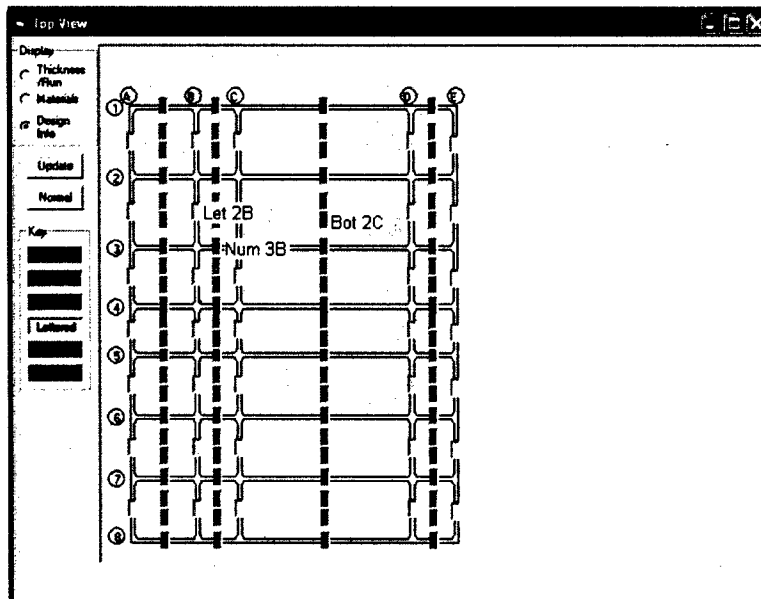

Figure B64. Request design results using the top view

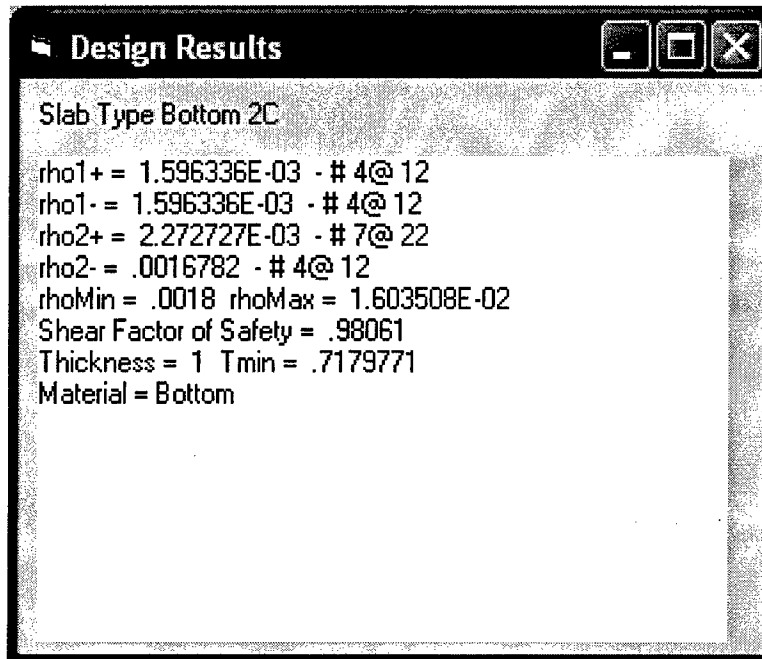

Figure B65. Design of large bottom slab

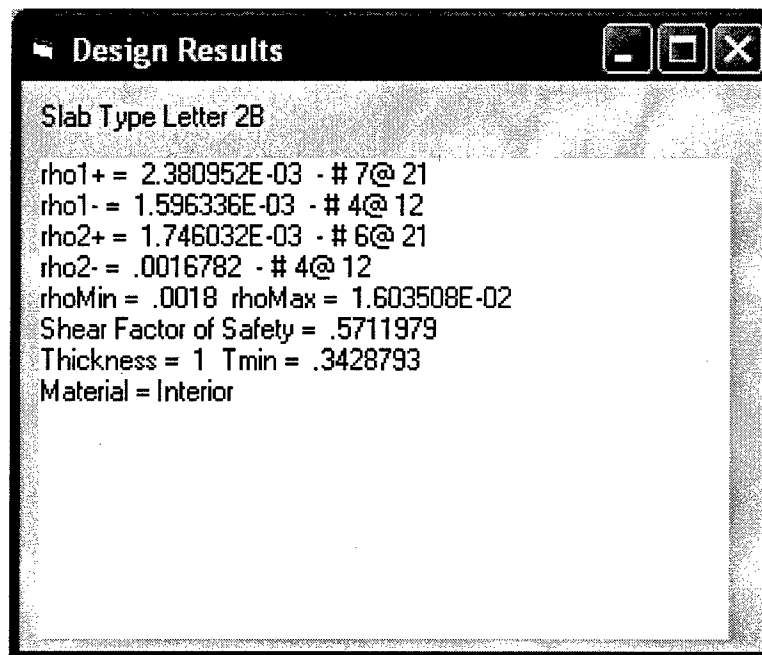

Figure B66. Design of wall of filled cell

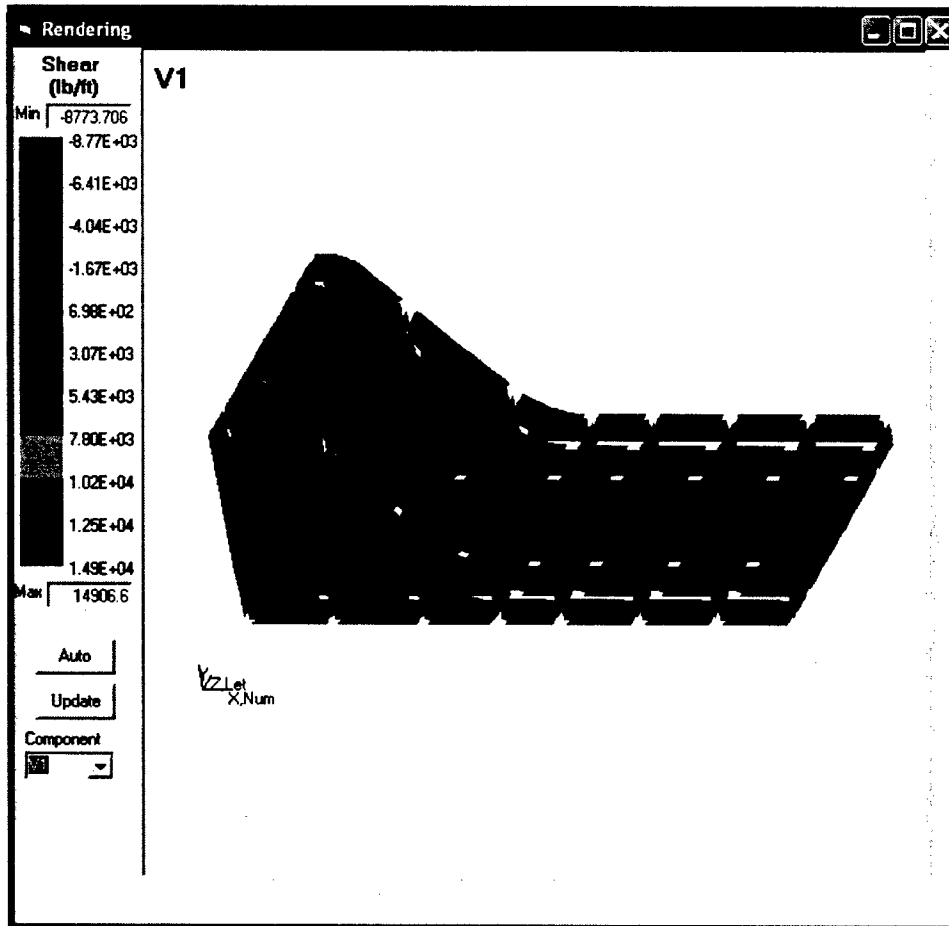

Figure B67. Review high shears in vertical slab

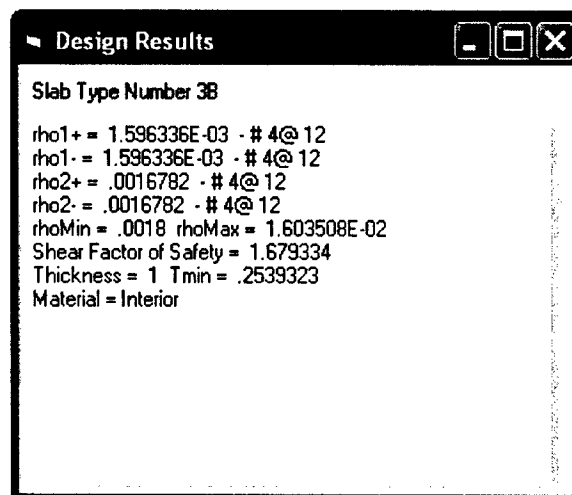

Figure B68. Design of smaller wall of filled cell

The final option for postprocessing is to view stresses on cross sections and generate Shear, Moment, and Thrust diagrams. The Mid Plane between section lines A and B is selected using the Plot Control form (Figure B69). The horizontal stresses are displayed in Figure B70.

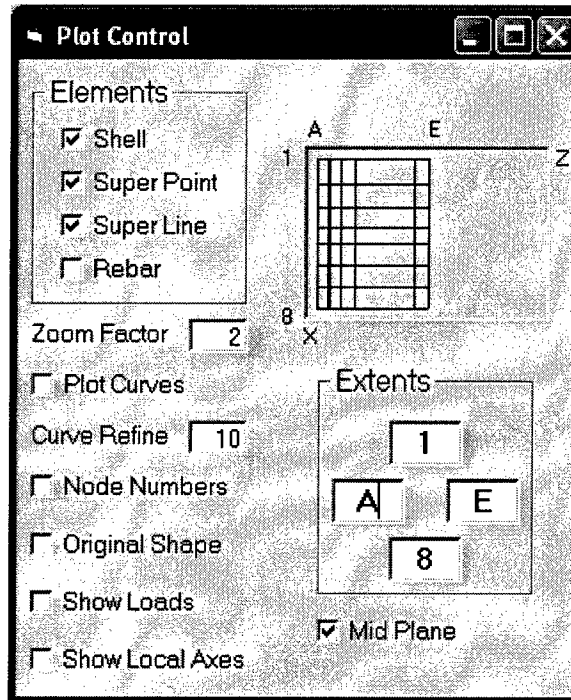

Figure B69. Select mid plane for plotting

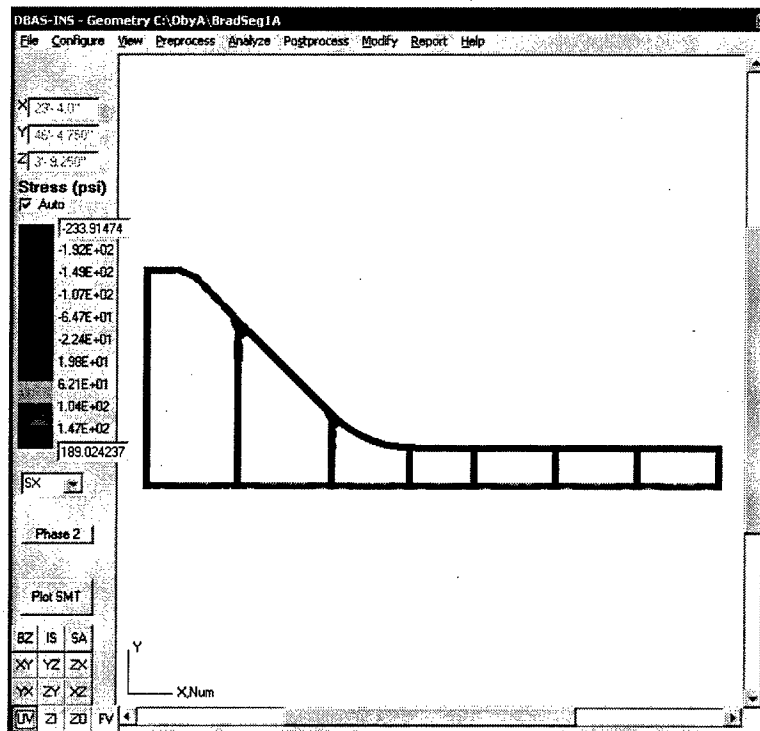

Figure B70. The X stresses in the cross section indicated in Figure B69

A new cross section is selected in Figure B71, and the X stresses are plotted in Figure B72. Note that the flexural stresses indicate a negative moment in the bottom slabs caused by upward pressure on the floating structure.

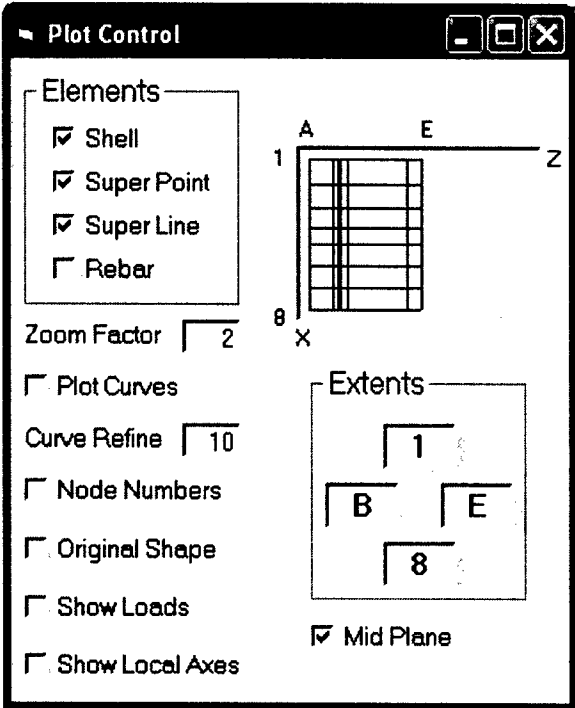

Figure B71. Select mid plane through the filled cell

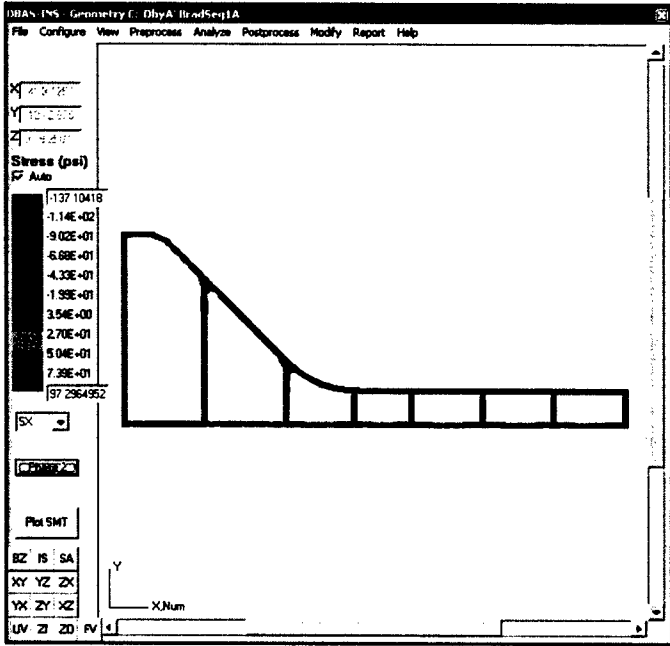

Figure B72. Plot X stresses on cross section

To investigate flexural stress in the diaphragm walls around the filled cells, the Y-direction stresses (SY) are plotted (Figure B73). The view is then rotated by plotting YX, the Plot SMT button is clicked to open the Shear Moment Thrust form (Figure B74), and Select Box is clicked in order to highlight the slab of interest (Figure B75). The view was rotated because the SMT plotting routine cuts cross sections in the vertical direction to evaluate moment. Figure B76 is a moment diagram for the selected region.

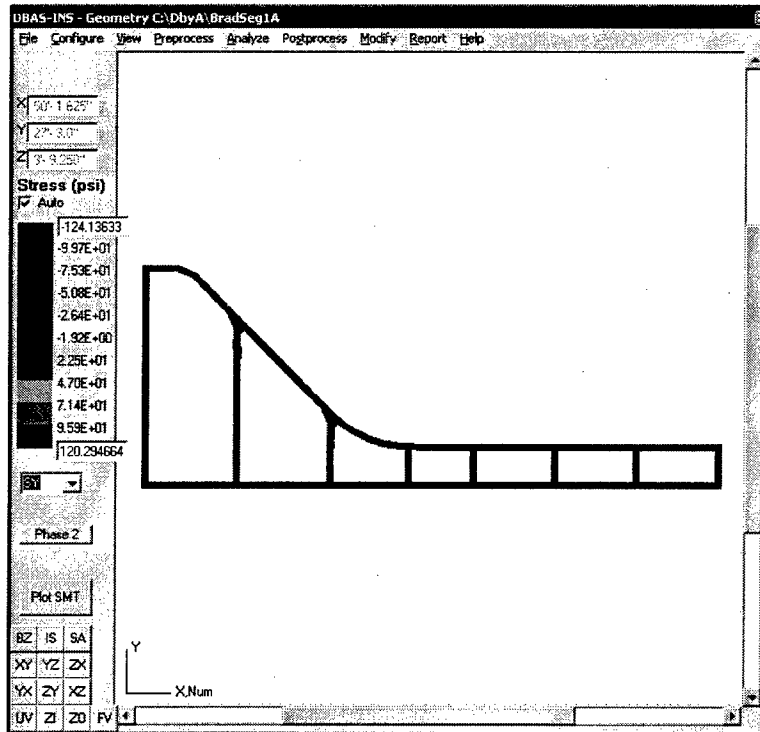

Figure B73. Plot vertical (Y) stresses on cross section

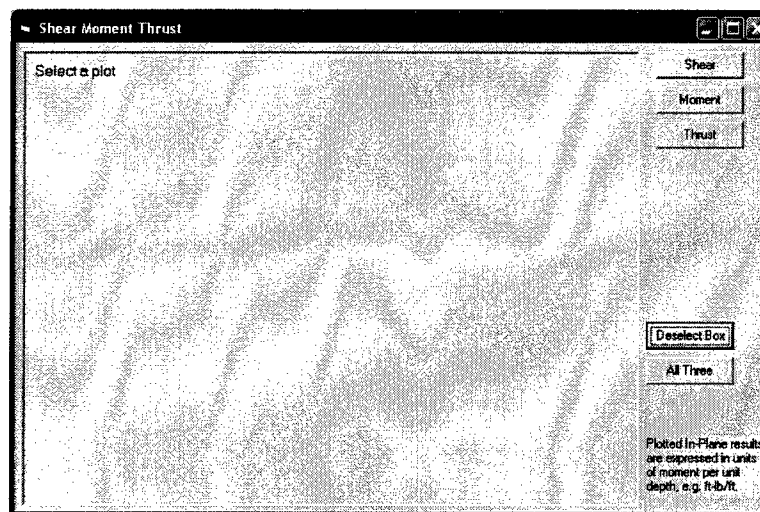

Figure B74. Shear Moment Thrust form

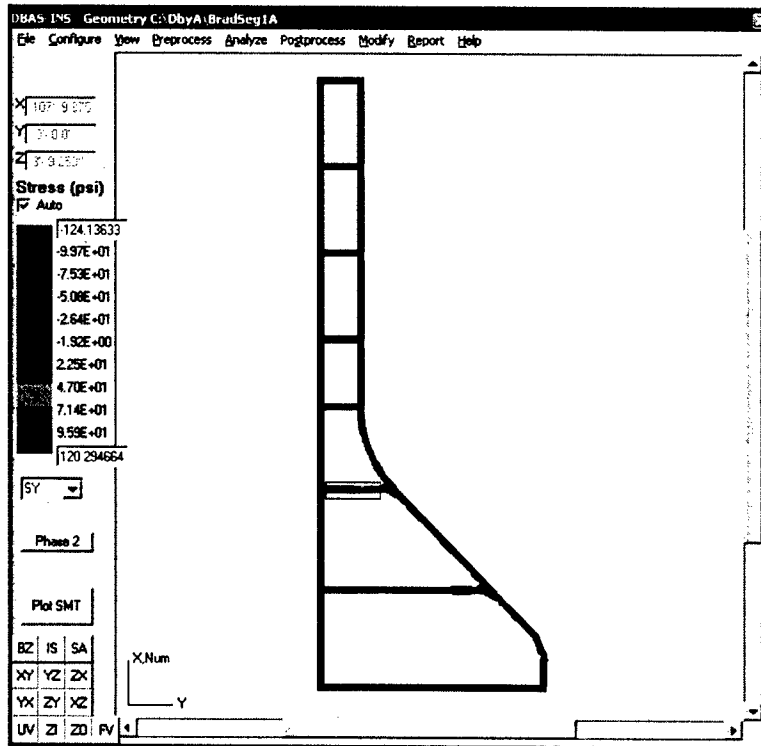

Figure B75. Create YX plot and select box for SMT diagram

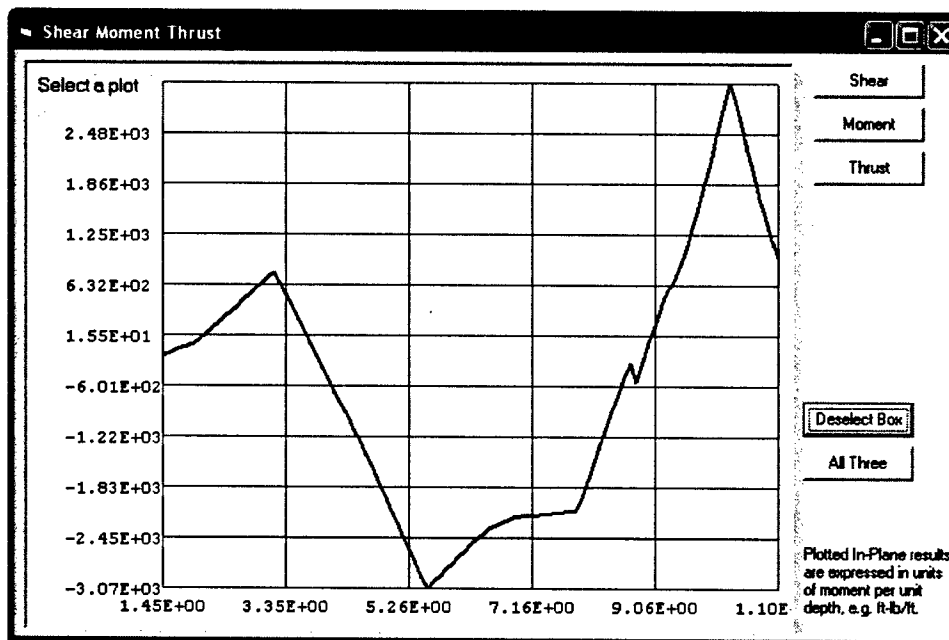

Figure B76. Moment diagram for selected diaphragm wall

All significant load cases would be analyzed and the worst case for each slab identified by the computer program in order to determine the final design. The thickness of slabs would be modified in the Redesign phase (either automatically or manually by the user) to develop the most efficient design that satisfied all criteria. Finally, a report is generated to document the results of the analysis.

# Appendix C

## Neutral Geometry File Format

---

The neutral geometry file describes the lines elements generated by the program. The first line is a number denoting the total number of line segments defined in the file. Each subsequent line consists of an integer value indicating the data set to which the line is assigned, followed by six single precision numbers that give the X, Y, and Z coordinates of the end points of the lines. Curves are broken into line segments.

- LINE 1: Number of line segment in the file – N
- LINES 2 – N+1: Data set number, X1, Y1, Z1, X2, Y2, Z2

# REPORT DOCUMENTATION PAGE

*Form Approved*  
**OMB No. 0704-0188**

Public reporting burden for this collection of information is estimated to average 1 hour per response, including the time for reviewing instructions, searching existing data sources, gathering and maintaining the data needed, and completing and reviewing this collection of information. Send comments regarding this burden estimate or any other aspect of this collection of information, including suggestions for reducing this burden to Department of Defense, Washington Headquarters Services, Directorate for Information Operations and Reports (0704-0188), 1215 Jefferson Davis Highway, Suite 1204, Arlington, VA 22202-4302. Respondents should be aware that notwithstanding any other provision of law, no person shall be subject to any penalty for failing to comply with a collection of information if it does not display a currently valid OMB control number. **PLEASE DO NOT RETURN YOUR FORM TO THE ABOVE ADDRESS.**

<b>1. REPORT DATE (DD-MM-YYYY)</b> August 2003	<b>2. REPORT TYPE</b> Final report	<b>3. DATES COVERED (From - To)</b>
---	---------------------------------------	-------------------------------------

<b>4. TITLE AND SUBTITLE</b>  Design by Analysis of Innovative Navigation Structures; User Manual	<b>5a. CONTRACT NUMBER</b>
	<b>5b. GRANT NUMBER</b>
	<b>5c. PROGRAM ELEMENT NUMBER</b>

<b>6. AUTHOR(S)</b>  Kerry T. Slattery, Guillermo A. Riveros	<b>5d. PROJECT NUMBER</b>
	<b>5e. TASK NUMBER</b>
	<b>5f. WORK UNIT NUMBER</b> 33273

<b>7. PERFORMING ORGANIZATION NAME(S) AND ADDRESS(ES)</b>  Southern Illinois University, Carbondale, IL 62901; U.S. Army Engineer Research and Development Center Information Technology Laboratory 3909 Halls Ferry Road Vicksburg, MS 39180-6199	<b>8. PERFORMING ORGANIZATION REPORT NUMBER</b>  ERDC/ITL TR-03-5
--	---

<b>9. SPONSORING / MONITORING AGENCY NAME(S) AND ADDRESS(ES)</b>  U.S. Army Corps of Engineers Washington, DC 20314-1000	<b>10. SPONSOR/MONITOR'S ACRONYM(S)</b>
	<b>11. SPONSOR/MONITOR'S REPORT NUMBER(S)</b>

**12. DISTRIBUTION / AVAILABILITY STATEMENT**  
  
Approved for public release; distribution is unlimited.

**13. SUPPLEMENTARY NOTES**  
  
The companion to this report is ERDC/ITL TR-03-4, "Design by Analysis of Innovative Navigation Structures; Theoretical Manual."

**14. ABSTRACT**

This report is the user manual for the "Design by Analysis System-Innovative Navigation Structures" (DBAS-INS). The Windows-based computer program creates a solid, three-dimensional (3D) finite element model of innovative structures fabricated using "in-the-wet" construction methods, such as the Braddock Dam currently under construction in the U.S. Army Corps of Engineers' Pittsburgh District. These structures are initially fabricated as a floating shell in a dry dock. The floating shell is divided into a 2D grid of hollow cells separated by reinforced concrete walls. Most significant structural loads involve hydrostatic pressures on the walls as the segment is floated to the installation site, lowered to the foundation, and filled with tremie concrete. The individual concrete slabs that form the walls of the cells must be designed for shear, moment, and thrust loads caused by the expected load combinations on the structure.

DBAS-INS procedures were developed to assist in the design and analysis of innovative navigation structures by simplifying the steps required to describe a new design, create a finite element model, check all load cases, design the reinforced concrete structure, and study modifications to the design. The DBAS-INS program allows the designer to create an accurate finite element model for a

(Continued)

<b>15. SUBJECT TERMS</b>	Plates and shells Pontoon structures Reinforced concrete	Thin-wall panels Two-way slabs
--------------------------	--	-----------------------------------

<b>16. SECURITY CLASSIFICATION OF:</b>			<b>17. LIMITATION OF ABSTRACT</b>	<b>18. NUMBER OF PAGES</b>  142	<b>19a. NAME OF RESPONSIBLE PERSON</b> Guillermo A. Riveros
<b>a. REPORT</b> UNCLASSIFIED	<b>b. ABSTRACT</b> UNCLASSIFIED	<b>c. THIS PAGE</b> UNCLASSIFIED			<b>19b. TELEPHONE NUMBER (include area code)</b> 601-634-4476

**14. (Concluded)**

complex, 3D structure and to complete a preliminary layout and design in a fraction of the time normally required. After analysis, the program checks design requirements per ACI 318-02 (American Concrete Institute "Building Code Requirements for Structural Concrete") and, based on these results, can automatically modify the design and reanalyze the model.