

**NAVAL POSTGRADUATE SCHOOL
Monterey, California**



THESIS

**THE IMPACT OF NEW TECHNOLOGIES ON SHIPBOARD
COMMAND AND CONTROL**

by

Matthew C. Erickson
Trey D. Oats

June 2003

Thesis Advisor:
Second Reader:

Orin Marvel
Curt Schleher

Approved for public release; distribution is unlimited

THIS PAGE INTENTIONALLY LEFT BLANK

REPORT DOCUMENTATION PAGE			Form Approved OMB No. 0704-0188	
Public reporting burden for this collection of information is estimated to average 1 hour per response, including the time for reviewing instruction, searching existing data sources, gathering and maintaining the data needed, and completing and reviewing the collection of information. Send comments regarding this burden estimate or any other aspect of this collection of information, including suggestions for reducing this burden, to Washington headquarters Services, Directorate for Information Operations and Reports, 1215 Jefferson Davis Highway, Suite 1204, Arlington, VA 22202-4302, and to the Office of Management and Budget, Paperwork Reduction Project (0704-0188) Washington DC 20503.				
1. AGENCY USE ONLY (Leave blank)		2. REPORT DATE June 2003	3. REPORT TYPE AND DATES COVERED Master's Thesis	
4. TITLE AND SUBTITLE: The Impact on New Technologies on Shipboard Command and Control.			5. FUNDING NUMBERS	
6. AUTHOR(S) Matthew C. Erickson and Trey D. Oats				
7. PERFORMING ORGANIZATION NAME(S) AND ADDRESS(ES) Naval Postgraduate School Monterey, CA 93943-5000			8. PERFORMING ORGANIZATION REPORT NUMBER	
9. SPONSORING /MONITORING AGENCY NAME(S) AND ADDRESS(ES) N/A			10. SPONSORING/MONITORING AGENCY REPORT NUMBER	
11. SUPPLEMENTARY NOTES The views expressed in this thesis are those of the author and do not reflect the official policy or position of the Department of Defense or the U.S. Government.				
12a. DISTRIBUTION / AVAILABILITY STATEMENT Approved for public release; distribution is unlimited			12b. DISTRIBUTION CODE	
13. ABSTRACT (maximum 200 words) An investigation of how fuel cells, an integrated power system, and directed energy weapons will affect the shipboard command and control process. The focus is on the implementation of the new technologies onboard near-term and far-term destroyer variants and the resulting changes to the command and control process.				
14. SUBJECT TERMS Fuel Cells, Integrated Power System, Directed Energy Weapons, Command and Control			15. NUMBER OF PAGES 93	
16. PRICE CODE				
17. SECURITY CLASSIFICATION OF REPORT Unclassified	18. SECURITY CLASSIFICATION OF THIS PAGE Unclassified	19. SECURITY CLASSIFICATION OF ABSTRACT Unclassified	20. LIMITATION OF ABSTRACT UL	

THIS PAGE INTENTIONALLY LEFT BLANK

Approved for public release; distribution is unlimited

**THE IMPACT OF NEW TECHNOLOGIES ON SHIPBOARD
COMMAND AND CONTROL**

Matthew C. Erickson
Ensign, United States Navy Reserve
B.S., Norwich University, 2002

Trey D. Oats
Ensign, United States Navy Reserve
B.S., United States Naval Academy, 2002

Submitted in partial fulfillment of the
requirements for the degree of

**MASTER OF SCIENCE IN SYSTEMS TECHNOLOGY
(Joint Command, Control, Communications (C3))**

from the

**NAVAL POSTGRADUATE SCHOOL
JUNE 2003**

Authors: Matthew C. Erickson
Trey D. Oats

Approved by: Orin Marvel
Thesis Advisor

Curt Schleher
Second Reader

Dan C. Boger
Chairman, Department of Information Sciences

THIS PAGE INTENTIONALLY LEFT BLANK

ABSTRACT

An investigation of how fuel cells, an integrated power system, and directed energy weapons will affect the shipboard command and control process. The focus is on the implementation of the new technologies onboard near-term and far-term destroyer variants and the resulting changes to the command and control process.

THIS PAGE INTENTIONALLY LEFT BLANK

TABLE OF CONTENTS

I.	INTRODUCTION	1
A.	DYNAMIC AND CHANGING WORLD	1
	1. Adaptation from Previous World	1
	2. Difficult Choices on the Horizon	1
B.	PRESIDENTIAL BUDGET	2
	1. Introduction	2
	2. \$700M for Hydrogen Fuel Research	2
	3. DOD Budget	2
	a. 16.9% of 2004 Budget	2
	b. \$7.7B for Missile Defense	3
	c. Fluctuation of Fleet Size	3
C.	DESTROYER INTRODUCTION	3
	1. History	4
	2. What the Future Holds for the Destroyer Navy ..	4
	3. Mission	5
	a. Anti-Air	5
	b. Sub-Surface	6
	c. Surface	6
	d. Strike	6
D.	THESIS SCENARIO: A NEW CLASS OF DESTROYER	6
	1. Near-Term Destroyer	7
	2. Far-Term Destroyer	8
E.	PURPOSE OF THESIS	9
II.	BACKGROUND DISCUSSION	11
A.	INTRODUCTION	11
	1. Transitional Phase	11
B.	FUEL CELLS	13
	1. Fuel Cell Basics	13
	a. History	13
	b. Chemistry	14
	c. How It Works	16
	d. What It Provides	17
	2. Types of Fuel Cells	18
	a. Proton Exchange Membrane	18
	b. Phosphoric Acid	20
	c. Molten Carbonate	21
	3. Current Uses	22
	a. Automobiles	23
	b. Utilities	24
	c. Others	25
C.	INTEGRATED POWER SYSTEM	25

1.	History	25
a.	CNO Objective	26
2.	Current Research in Heightened Reliability of IPS	26
a.	Trident Scholars Research	26
3.	The Future Implementation of Research	28
a.	What It Is Attempting to Do?	28
b.	How It Will Benefit the USN?	30
4.	The Integration of Fuel Cells with IPS	31
a.	What This Will Allow?	31
b.	Output Expectations	32
c.	The Evolution of Shipboard Design/Configuration	32
D.	DIRECTED ENERGY WEAPONS	33
1.	Introduction	33
a.	History	33
2.	Lasers	34
a.	How They Work?	34
b.	Laser Types	37
c.	Mirrors and Targeting Systems	38
d.	Laser Damage	39
e.	Advantages	39
f.	Disadvantages	40
3.	High Power Microwave and Ultra Wideband Systems	41
a.	How They Work?	42
b.	What They Will Require?	44
c.	Characteristics	45
III.	COMMAND AND CONTROL IMPLICATIONS	47
A.	INTRODUCTION	47
1.	Near-Term Destroyer (5 to 10 Years)	47
a.	C2 Integration Expectations	48
b.	Fuel Cell C2 Expectations	49
c.	IPS C2 Expectations	51
d.	C2 Modularity Benefits	51
B.	FAR-TERM DESTROYER (20 TO 30 YEARS)	52
1.	Directed Energy Weapons (DEW)	53
2.	Battlespace Commander Influence	53
3.	Implementation Options	54
a.	What It Offers	54
b.	Types of Systems That Will Be Implemented	55
c.	How the Systems Will Be Implemented	56
4.	DEW and the C2 Process	56
C.	ORGANIZATIONAL STRUCTURE	58
1.	NEAR-TERM DESTROYER	59

2.	Far-Term Destroyer	60
3.	Possible Structure Changes	61
4.	Operational Combat Environment	64
D.	SUMMARY OF EFFECTS IN C ²	66
IV.	RECOMMENDATIONS	67
A.	OVERVIEW	67
B.	CRITICAL TECHNOLOGIES	67
1.	Fuel Cells	67
2.	Integrated Power System	68
3.	Directed Energy Weapons	69
C.	RECOMMENDATIONS	69
	LIST OF REFERENCES	71
	INITIAL DISTRIBUTION LIST	75

THIS PAGE INTENTIONALLY LEFT BLANK

LIST OF FIGURES

Figure 1. Shipboard Implementation of New Technologies	11
Figure 2. Phosphoric Acid and PEM Fuel Cell (from http://fuelcells.si.edu/basics.htm)	19
Figure 3. Molten Carbonate Fuel Cell (from http://fuelcells.si.edu/basics.htm)	21
Figure 4. Toyota FCHV-4 (from http://www.unr.edu/chemengr/chel101/fuelcells.htm)	23
Figure 5. Transformation to IPS (from Zivi, John Hopkins, 1999)	29
Figure 6. IPS Management (from McCoy, 5 th Naval Engineering Conference, 2000)	31
Figure 7. Stimulated Emissions to Produce Lasers (from http://science.howstuffworks.com/laser2.htm)	36
Figure 8. Underway Organizational Structure	61
Figure 9. Integrated Operational Combat Environment	65

THIS PAGE INTENTIONALLY LEFT BLANK

ACKNOWLEDGMENTS

We would like to thank Professor Orin Marvel for his support and dedication in helping us complete this thesis. Also, we would like to thank Professor Curt Schleher for offering his time and expertise with DEW.

Additionally, we would like to thank Assistant Professor Edwin Zivi, Weapons and Systems Engineering Department, U.S. Naval Academy for his guidance and direction with the integrated power system. Also, the research of Cerrito, Chiafair, and Vanecko during their Trident Scholar research at USNA proved to be very helpful.

THIS PAGE INTENTIONALLY LEFT BLANK

EXECUTIVE SUMMARY

During his visit to the Naval Postgraduate School on 16 May 2003, the Honorable Hansford T. Johnson, Acting Secretary of the Navy, addressed the students during a Superintendent's Guest Lecture. During the question and answer session, the Secretary addressed many of the themes of this thesis: modularity, integrated power systems (IPS), electric drive propulsion, and electric pulse weapons.

Modularity was a key topic of discussion at the briefing. By allowing plug-and-play suites to be added and removed from vessels, specific mission needs can be met more effectively. Guns can be changed 3 to 4 times, and electronics can be upgraded 10 to 20 times. This flexibility allows vessels to be more versatile and capable of dealing with the various threats that arise in future conflicts.

Vessels will utilize IPS and electric drive propulsion. By using electric drive solutions, the bulky mechanical propulsion systems will be replaced with electric motors, allowing for smaller engineering spaces. On the current destroyers, power flows from two auxiliary rooms for ships services and separately from the two main engine rooms to all engineering spaces for propulsion. The previous method does not allow for redundancy or transfer of power, as future systems will require raw power to be delivered to the IPS for distribution to all systems during normal operations as well as times of crisis. "The power of routing power or electricity is amazing", said Johnson.

Electric pulse weapons (known as directed energy weapons) are defensive weapons that use lasers or microwave technologies to defend against enemy threats. The IPS will manage the large power requirements of these weapon systems, as well as normal ship operating systems. The success of the IPS will be a cornerstone for the implementation of directed energy weapons.

This thesis focuses on the implementation of the new and emerging technologies mentioned previously (with the addition of fuel cells to fulfill the requirements of a powerplant) and their implications for shipboard command and control on future naval vessels. Each of these technologies offers both advantages and disadvantages, which will affect the overall shipboard command and control process. By addressing the issues that arise, better decisions can be made about the future development of combat vessels.

I. INTRODUCTION

A. DYNAMIC AND CHANGING WORLD

America is currently at a crossroads, trying to defend against unknown enemies that do not play by traditional rules. Today the road is different than the one we traveled just a few years ago, one we thought we knew. Our preparation was for large-scale battles, fought on epic proportions, with nuclear weapons if need be. The days of fighting known enemies are becoming rare and thus, the world is in a transitional phase seeking balance.

This crossroads offers two paths. One path leads to isolationism, which was preached and embraced at the beginning of this century. That was a road that could not be traveled for very long. The other path, difficult and dangerous as it may be, requires us to export security - America's greatest commodity [Ref. 1] in support of our freedoms.

1. Adaptation from Previous World

Our nation's role in the world must change in order to ensure the challenges associated with the transition are met. The only way to adapt our nation's role is by a looking into the future and developing a course of action that deals with the emerging and advancing threats. We as a nation must define our goals, develop a new model from which we can project our power, and plot a course for our future.

2. Difficult Choices on the Horizon

In a very dynamic and uncertain world, it is the responsibility of America to defend herself against the increasing threats to her national security as well as the

safety of the world. The design of this thesis is to investigate an option that will prevent these threats from having a negative impact on our culture.

B. PRESIDENTIAL BUDGET

1. Introduction

In February of 2003, the President of the United States (POTUS) presented a strong case in the State of the Union Address for the future advancement of fuel cells as a new technology for producing energy. Supported with strong evidence of declining oil resources and an ever-growing societal urge to be more environmentally friendly, President George W. Bush with the support of Congress has taken the first step towards the nationwide implementation of fuel cells and the benefits that they bring.

2. \$700M for Hydrogen Fuel Research

With the advancement of funding for fuel cell research by the Bush administration, America is on the brink of a massive evolution. The current daily life dependent on fossil fuels will evolve to a life in which alternative fuels are utilized to provide an efficient, environmentally friendly means power. This transition will be made possible with the adequate funding of research.

3. DOD Budget

a. 16.9% of 2004 Budget

This new budget extends benefits and funding to the military for fulfillment of their Title 10 objectives and responsibilities. With the proposed \$380 billion dollars allocated to the DOD for *transformational* projects, there are many avenues of interest and each branch of the service will benefit in their own way. With the current

buzzword being transformation, all of the services continue to demonstrate their beliefs by labeling their new projects as *transformational*. Additionally, many of their old projects have now gained the title of *transformational* in order to attain budget allotment.

b. \$7.7B for Missile Defense

The new budget calls for the Pentagon to send 7.7 billion dollars to the Missile Defense Agency (MDA). [Ref. 2] This money has been allotted in order to fulfill the mission needs statement (MNS) for a system capable of protecting the nation from incoming theater ballistic missiles. Included in the budget is the prescriptive for at least ten land-based interceptor sites. [Ref. 3]

c. Fluctuation of Fleet Size

Throughout history, there has been a struggle by the Navy to maintain its fleet in numbers, as others have sought to streamline and reduce the size of the force. The US Navy fleet currently has 301 ships and is on its way down to 291 ships within the next three years. The entire DD fleet will be phased out during this period. However, there is hope within the Department of the Navy, which was inspired with a firm commitment by the Bush administration "to revive the size of the fleet...to 305 by 2009." [Ref. 4]

C. DESTROYER INTRODUCTION

The destroyer is a strong and **steadfast** vessel, which for just over a century has been at the forefront of our national defense. This craft, evolving as the times change, has the ability to project power from the sea in support of our national interests.

1. History

The destroyer evolved to fulfill the needs of the Navy during the late 19th Century. The need was for a vessel able to counter and repel small torpedo boats that could rush in, release weapons, and cause havoc. Navies worldwide noticed the lack of protection against such threats and sought a solution - thus the destroyer was born.

The first US Navy destroyer was commissioned in 1902. The USS Bainbridge was the first of an ever-emerging destroyer fleet to sail the high seas and did so during World War I serving as a patrol and convoy escort in the Atlantic. The smart actions by early ship-drivers set the tone for the evolution of the destroyer navy. Over time, the destroyer has carried many heroic names such as the Spruance-Class and the Arleigh Burke-class. The fleet continues to change as we evolve with the destroyer. Currently, slated for introduction to the destroyer fleet is the DD21 which has been renamed as the DD(X).

2. What the Future Holds for the Destroyer Navy

Despite the destroyer's vigilance and past glories, a problem still remains. For all the great and innovative technologies the ship possesses, it is still very vulnerable. It is still a frail vessel susceptible to the hostile world environment that seeks to destroy what it represents. With this being said American destroyers need to be upgraded, fitted with the newest technologies that will provide the platform with the ability to maintain dominance, operate forward from the sea, and sustain its

mission. These upgrades will allow the ship commanders a greater degree of control in evolving uncertain environments that will see in the coming years.

The DD(X) (DD-21) is the most recent grasp at the future of the US Navy destroyers. The new design will support joint-service requirements in littoral regions. The DD(X) is outfitted with a wide range of land-attack weapons and can provide both offensive and defensive measures from a forward based platform. The program calls for the use and development of electric drive and the introduction of the Integrated Power System (IPS). These changes along with the directives set for the destroyer will make the destroyer a potent weapon for the United States.

3. Mission

The Arleigh Burke Class destroyer (DDG-51) is the most advanced multi-mission ship the world has ever seen. These agile warships provide both offensive and defensive capabilities for global operations. Around the globe, capable of acting alone, but mostly in conjunction with a battle group, surface action group, or amphibious ready group, destroyers present a force of power in the sea much the same as the carrier of past decades. Forward from the sea, acting as a strong platform from which American interests can be projected, the destroyer is key to America's success in the high seas.

a. Anti-Air

Destroyers in today's Navy possess the ability to track and launch upon air targets. The ability to access and launch on air threats is due to the advanced combat system center which encompasses the Aegis combat system

along with the SPY-1D phased array radar. This duo provides for the destroyers' superiority in the anti-air arena.

b. Sub-Surface

The DDG's advanced anti-submarine capabilities add to its armament in the sea. The 12.75" triple torpedo tubes along either side of the centerline provide coverage to threaten the ever-dauntless submarine force. In addition, the DDG's have a highly trained crew operating the sonar system (SLQ 32), which is at the top of its class in both respects. The flight II-A includes a dual helicopter hanger for flight ops such as sub-hunting. This addition to the DDG is one of many advances that continue the revolution at sea.

c. Surface

The DDG has a Vertical Launch System, Mk-41, with 29 cells forward and 41 cells aft on the flight I and II. The flight II-A has done away with the crane and carries an additional three cells both forward and aft. With the VLS, the DDG is capable of firing the harpoon missile, TASM, as well as other anti-surface missiles to eliminate hostile contacts.

d. Strike

Utilizing the Mk-41 VLS as mentioned above, the DDG is capable of firing an assortment of missiles at hostile land targets. To fulfill the strike mission, the DDG has the LAM variant of the Tomahawk.

D. THESIS SCENARIO: A NEW CLASS OF DESTROYER

Continuing in its evolutionary trend and fulfilling the needs of the navy, the destroyer navy is moving forward

from the previous Arleigh Burke Class to the near-term and far-term platforms. These ships are designed to face the dynamic and changing world. They are capable of operating effectively in the shallower littoral waters where the future conflicts are projected to occur. These ships can add a higher degree of protection to the battle group, or can serve independently in combat.

The focus of this thesis will be on the destroyer. The analysis will focus on two parts: the near-term destroyer - one that could be fielded within 5-10 years; and the second, a far-term destroyer - one that could be fielded within the next 30 years. The destroyer has been chosen due to the fact that it is the most versatile of the naval vessels currently in the fleet.

1. Near-Term Destroyer

A new class of destroyers, authorized (funding secured) by Congress, will be discussed in the following scenario. It will be built to operate more closely to shore and its design will be taken from the family of littoral combat vessels. It will have a limited modular design, allowing additions of different mission and platform modules. The ship will focus on reduced manning and automation of systems. It will also be the first ship to be equipped with two radically different technologies: an IPS and fuel cells.

The IPS is designed to allow the entire ship to operated using electrical power, including the propulsion. This system will replace the bulky reduction gear and long shafts that turn the propellers and replace them with

electric motors for ship propulsion. This system is to be installed in accordance with the CNO directive that calls for the implementation of IPS on all future naval vessels.

Fuel cells will be introduced as the ship's primary source of power. The use of fuel cells onboard naval vessels will have to meet the power requirements of the near-term destroyer which are yet to be determined. However, the current Arleigh Burke destroyers produce two different types of power: propulsion and ship service. The power for propulsion is supplied by 4 LM-2500 gas turbines that supply a total of 100,000 shp or about 74,600kW. Additionally, three Allision 501 k-34 2500kW gas turbine generators provide the power to the ship systems. This means that the total power requirements, fully powering every system and operating at maximum speed, would be 8.21MW. The modular fuel cell power generation design coupled with an IPS will be capable of providing electric power in excess of 10MW for propulsion via electric motors and to the ships systems. The specifics of this technology will be discussed in detail later.

With these two systems in place, the ship is no longer required to maintain large mechanical systems that make the engineering space so large. Rather the fuel cells can be placed throughout the ship, allowing for increased survivability and allowing more space for weapon systems, supplies, the crew, etc...

2. Far-Term Destroyer

In this second model, the near-term destroyer has been very successful and Congress has authorized continued funding of the program. The MDA and other government agencies have conducted research in the area of directed

energy weapons (DEW). They have fielded systems and want to place them on a more mobile platform (the CVN will most likely already be fitted with this systems).

The vessel chosen is to be a modified version of the near-term vessel. This platform will introduce high-energy lasers (HEL) and high-powered microwaves (HPM) to the existing platform (kinetic energy weapons will still be operated from the ship). This platform will offer a higher-level of self-defense against anti-ship, anti-air, and other enemy threats. The addition of these upgrades will increase the battle groups defensive capabilities and its self-defense.

E. PURPOSE OF THESIS

The purpose of this thesis is to assess how changes in technology will affect the shipboard command and control process. An introduction to the new technologies, their advantages and disadvantages, and their affects on the command and control process, will be discussed. This thesis was written in the attempt to increase the combat potential and war-fighting capabilities of future naval vessels.

THIS PAGE INTENTIONALLY LEFT BLANK

II. BACKGROUND DISCUSSION

A. INTRODUCTION

The United States stands at the forefront of technological advances and continually develops cutting edge technologies. A world of emerging technologies remains yet to be discovered, and the push to find them is great. Along with the civilian sector, the DOD strives to find viable, new technologies. This continued push for discovery is the cornerstone of the new surface fleet.

1. Transitional Phase

The US destroyer fleet is currently in a transitional phase. The move from the flight II-A destroyer, to the near-term, and eventually to the far-term platform must be outlined with a roadmap. The following is a representation of future shipboard systems.

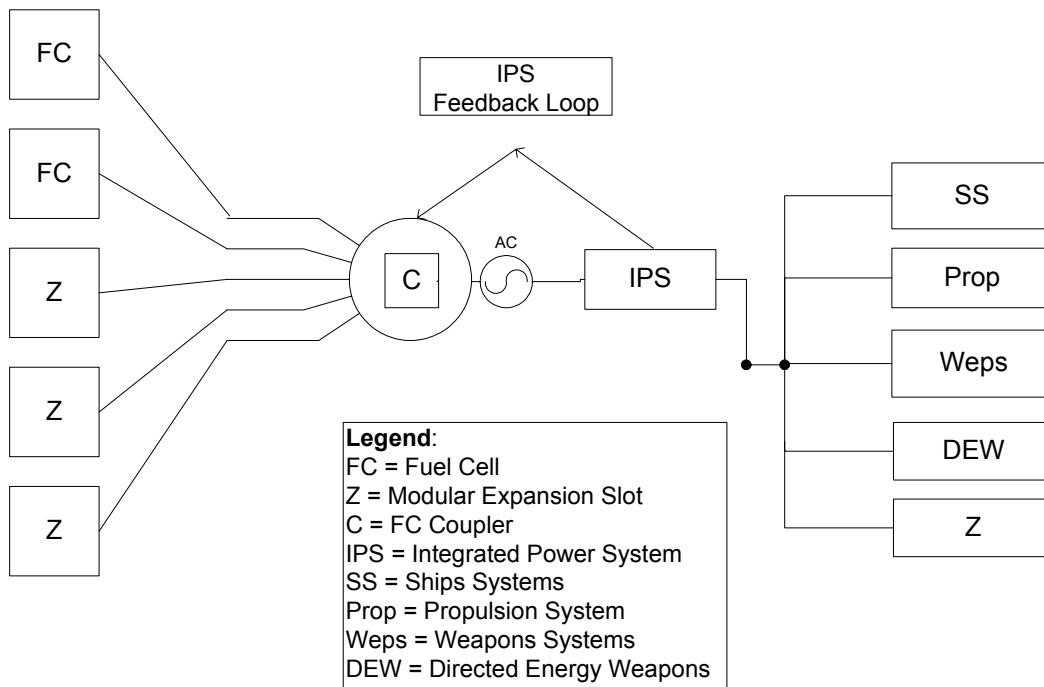

Figure 1. Shipboard Implementation of New Technologies

The technologies introduced above will be explained in greater detail in the following sections. However, Figure 1 shows the interconnection of the various ships systems and thus displays the big picture. This section will briefly explain the systems interaction.

Moving from left to right in Figure 1, the raw DC power from fuel cells (FC) will be harnessed with the FC Coupler. The FC system includes expansion slots that will allow for further evolution of the destroyer platform, meeting the increasing need for more power to operate more systems.

Next, the raw power will be modulated into AC before arriving to the Integrated Power System (IPS). The IPS is tasked with controlling the power flow from the fuel cells to each of the ships systems. The IPS is capable of rerouting the power during catastrophe, but this will be discussed in detail later.

The goal of the near-term destroyer is to implement the fuel cell and IPS technologies, working out any problems with the system. Looking further into the future, Figure 1 also includes an addition that will not arrive until the success of the near-term destroyer.

The far-term destroyer will include the integration of directed energy weapons (DEW). This is where the IPS will be met with its greatest challenge. The DEW will be discussed later in detail; but in short, the weapon uses large amounts of power in very short pulses. The IPS will be tasked with rerouting the power during this engagement phases, while keeping the ships systems in operation.

Lastly, the expansion slots (Z) on both sides of Figure 1 reinforce the benefits to a modular design in which FC's can be added as necessary to power more potential weapon systems that evolve with time.

B. FUEL CELLS

From sail to steam to the gas turbine generators, the American surface fleet has harnessed the most powerful technologies available. With this evolution of technology, the time has come to change again. The shift will be to a very efficient and dynamically different system - the fuel cell.

1. Fuel Cell Basics

A fuel cell is an electrochemical device that converts hydrogen and oxygen into water, without using combustion. The by-products of this reaction are electricity and heat, which can be used to power anything requiring electrical power. It is one of the goals of this thesis to determine how fuel cells might be implemented on naval vessels.

a. History

Although it seems that fuel cells are a recent discovery, the first fuel cells were investigated over 150 years ago. In 1838, Sir William Grove, was recorded with creating the first fuel cell, which was later called the Groove cell. In this reaction he used two platinum electrodes, with one end immersed in sulfuric acid and the other end in sealed containers of hydrogen and oxygen, which produced a current flow. The vessels contained both water and gases. Grooves noticed the water level changed as the current flowed. [Ref. 5]

It was not until 1893, when Friedrich Wilhelm Ostwald provided a theoretical understanding of how all the elements within fuel cells were interconnected. Through his experiments, he was able to show how the electrodes, electrolyte, oxidizing and reducing agents, anions, and cations worked together to make a fuel cell function. His exploration of the underlying chemistry of fuel cells laid the groundwork for later fuel cell research. [Ref. 6]

It was not until 1958 that the first modern fuel cell demonstration occurred. Francis Thomas Bacon, a British scientist who had been trying to develop feasible fuel cells for submarines during WWII, unveiled an operating 10-inch diameter alkali fuel cell stack. This is important, because Pratt & Whitney purchased Bacon's design and later used it in the Apollo space missions. This represents one the first uses of this technology in the modern era.

More research has gone into fuel cells, since NASA's use in the 60's and 70's however the use of fuel cells is still not widespread. There has been a lot of interest in fuel cells, especially in automotive and power industries, but until the technology is further perfected and its cost reduced, it will not be widely used.

b. Chemistry

At the heart of the fuel cell, is the electrochemical reaction that allows it to occur. An electrochemical reaction is a chemical reaction that produces electrical energy. The following is a description the chemistry involved in the use of a Proton Exchange Membrane (PEM) fuel cell. The chemistry is similar to what is found in all fuel cells.

There are terms that need to be introduced to help better understand the reaction that occurs within the fuel cell. The anode is the negative part of the fuel cell, where the hydrogen gas (H_2) is ionized and gives up its electrons (e^-). By stripping the hydrogen gas of its electrons, the hydrogen atom becomes positively charged (H^+) and a direct current (DC) is produced from the electrons. The e^- flow is through an external circuit from the anode to the cathode.

The cathode is the positive part of the fuel cell, where the oxygen gas (O_2) is ionized into elemental oxygen (O^{2-}). The O^{2-} and e^- combine with the H^+ atoms to form water.

A catalyst and electrolyte are also needed for this reaction to occur. The catalyst is a platinum (Pt) surface, on or around the anode and cathode, which helps the hydrogen-oxygen reaction to occur more readily. It splits the hydrogen and oxygen gases into their molecular components allowing the reaction to occur.

The electrolyte is a membrane, between the anode and cathode, which allows only certain charged particles through. In this case it allows only positively charged particles or $+$ to pass through. Without the electrolyte other particles such as e^- or O_2 , could pass through and possibly disrupt the reaction.

The reaction steps can be seen on the next page. The anode and cathode reactions occur independently and then combine, resulting in the overall reaction.

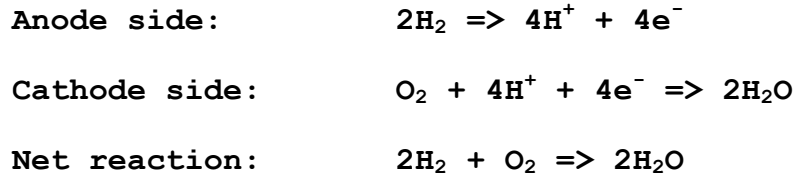

This is a relatively simple reaction that is well understood, but the process of engineering it into a workable product is somewhat more difficult.

c. How It Works

The chemistry is what drives the fuel cell, but a physical system is required to take advantage of this reaction. To do this three basic components are needed: the fuel processor or reformer, the fuel cell, and the inverter. With these three components a fuel cell system can properly function.

H₂ is currently the hydrogen source that most fuel cells utilize to produce electricity. However, H₂ is not the easiest gas to work with because it is extremely flammable, requires special containers, and takes a lot of energy to isolate^a. The reformer converts hydrocarbon fuels into H₂, which is then directed to the fuel cell. It also acts as a filter because small amounts of sulfur contained in the hydrocarbons may cause a drastic drop in power production. [Ref. 7]

The fuel cell is the most important component of the system. It is from here that all power is produced. It should be known that a single PEM fuel cell reaction

^a The President is investing heavily in the research to make H₂ more available. One of the reasons for the funding is the fact that there will be widespread use of the fuel cells in the future. Sources and technology that supports larger scale use of the gas will be required. Until this occurs, fuel cells will need reformers, which limits the overall efficiency of the systems.

produces a voltage of about .7 Volts. [Ref. 8] To get better output, stacks of fuel cells are used to increase the power density.

The inverter converts the raw DC output of the fuel cell into an alternating current (AC). This process is essential, because most shipboard systems cannot use DC.

d. What It Provides

The goal of the fuel cell is to provide a clean, efficient, and viable source of power. The following section is dedicated to address the means by which the fuel cell will provide these benefits.

(1) Pollution. The fuel cell produces less pollution than an internal combustion engine, with the only noticeable emissions being H₂O and CO₂. This process is accomplished because the fuel cell does not ignite hydrocarbons and release unburned hydrocarbons, carbon monoxide (CO), nitrous oxide (NO_x), and other green house gases into the atmosphere, as does an internal combustion engine. With the use of fuel cells, these pollutants are in effect non-existent. [Ref. 9]

(2) Efficiency. The efficiency of the fuel cell is based on the fact that it is not a combustion reaction and therefore not limited by thermodynamic principles. Since it can produce electricity using chemical reactions, the efficiencies are much higher. The chemical conversion of H₂ into electricity can be up to 80% efficient [Ref. 10], but with the use of the fuel processor and inverter, the efficiency drops to about 24 - 32%. Creating fuel cells that can use pure H₂, without reforming hydrocarbons, would be extremely efficient.

(3) Cogeneration. Fuel cells offer another advantage, cogeneration. With cogeneration, the waste heat produced from the fuel cell can be used for other applications. One solution is to use the waste heat to produce steam, which could be used to drive turbines, producing more electricity. Still another theory is to use the waste heat to drive the hydrocarbon reforming process.

(4) Heat Signature. With fuel cells, the heat signature of the ship that is given off to the environment will be reduced. The exhaust temperatures of fuel cells are significantly less than current naval systems, meaning that there is less heat released into the atmosphere. The heat signature of the ship is therefore reduced and less susceptible to attacks by heat-seeking missiles.

(5) Future. The use of fuel cells offers a viable alternative to the power systems used today. Coupling this technology with IPS, fuel cells could be used to power the grid and allow for improved shipboard distribution. This would be an advantage over the current systems.

2. Types of Fuel Cells

A recent study identified three types of fuel cells that would likely be adapted for shipboard use: Proton Exchange Membrane (PEMFC), Phosphoric Acid (PAFC), and Molten Carbonate (MCFC). The type of fuel cell is named after the electrolyte that it uses.

a. Proton Exchange Membrane

As the name suggests the electrolyte is a proton exchange membrane that allows H^+ to travel through it, see Figure 2. The PEM is a solid, thin, and permeable polymer sheet, resistant to leaks and cracks.

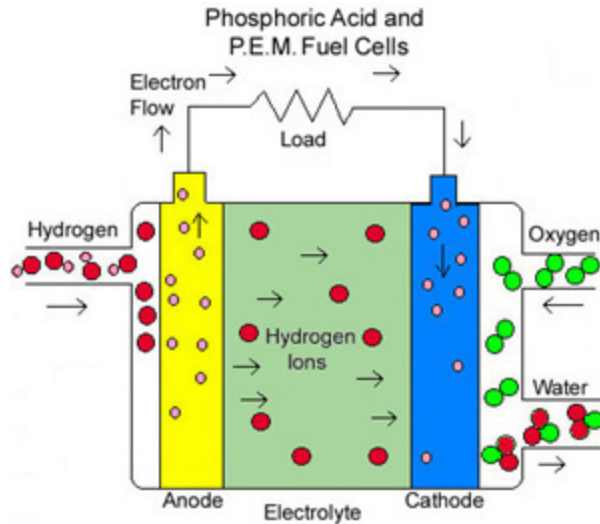

Figure 2. Phosphoric Acid and PEM Fuel Cell (from <http://fuelcells.si.edu/basics.htm>)

The PEMFC was selected because they show the most promise for naval use due to higher power density. [Ref. 11] They are also able to vary their output quickly to meet shifts in power demand. [Ref. 12] The PEMFC has outputs ranging from 50 - 250 kW. It has a relatively high efficiency, about 40 - 50%, and a low operating temperature, about 80°C.

The disadvantages lie in the fact that the catalyst used in this system is platinum (Pt). Pt is an extremely expensive metal, which will drive up the cost of the system. Also PEMFC systems have only been used on small scales, cars and small homes, not a naval vessel requiring massive amounts of power.

The PEMFC are the most desirable type of fuel cell from a ship impact point of view, however significant work must go into the research and development of a large-scale system. [Ref. 13] The PEMFC has a high power density, which is good for ship power systems, but is only

available in smaller sizes with limited capacity, which increases the uncertainty of shipboard implementation. Thus, further research and evolution of the technology will aid in the future implementation of a large-scale system.

b. Phosphoric Acid

In this fuel cell, phosphoric acid (H_2SO_4) is used as the electrolyte, which operates very similarly to the PEMFC as seen in Figure 2. However, this fuel cell represents a more mature technology and is the most commercially developed of the fuel cells. [Ref. 14] The PAFC was selected because of their current power generation capabilities and the maturity of the technology. [Ref. 15]

The PAFC must be run at high temperatures, because H_2SO_4 is a poor ionic conductor at low temperatures. When operating at temperatures of 150 - 200°C, efficiencies of 40 - 80% can occur. Currently the systems produce outputs of around 200kW, however 11MW PAFC systems are being developed.

Since PAFC are similar to the PEMFC, a Pt catalyst must be used, driving up the price. H_2SO_4 , although a stable electrolyte, is extremely corrosive and the internal parts of the system must be hardened to withstand its acidic nature.

PAFC show great promise because of their high efficiencies and the maturity of the technology, however they will cause an increase to the size of the vessel. Issues such as CO intolerances, start time, service life, and a hazardous electrolyte must be resolved before they become a viable shipboard platform. [Ref. 16]

c. Molten Carbonate

The molten carbonate fuel cell uses a carbonate salt, a solid, as the electrolyte. As the carbonate salt heats up, it liquefies and carbonate ions (CO_3) are transferred from the cathode to the anode. When they reach the anode, the H_2 and CO_3 ions react to form H_2O , CO_2 , and electrons. The CO_2 , e^- , and air, react to form more of the CO_3 ion at the cathode; thus, regenerating the electrolyte. This is only partial successful, because CO_2 usually has to be added to the system. Figure 3 illustrates how the MCFC works.

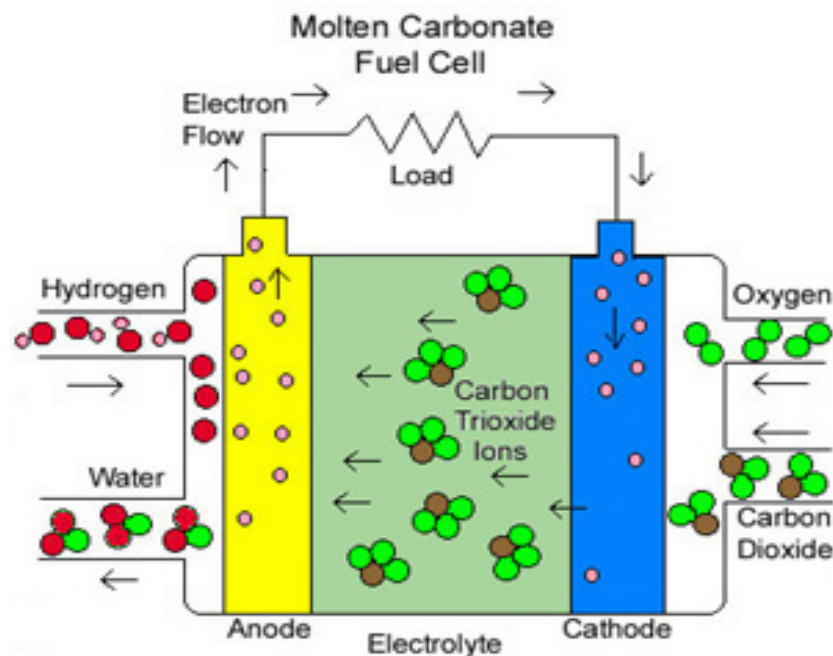

Figure 3. Molten Carbonate Fuel Cell (from <http://fuelcells.si.edu/basics.htm>)

The use of MCFC was investigated because their high efficiency and the bottoming cycle, which takes advantage of the high exhaust temperatures. [Ref. 17] The MCFC is a very efficient system, that can reach 60% and up

to 80% when the bottoming cycle or cogeneration is used. In the MCFC, the waste heat will be used to aid in the process of powering the reformer, to convert the hydrocarbons in the usable hydrogen. If a reformer could be built into the fuel cell itself - known as direct reforming, this would lower space requirements of the MCFC, therefore better suiting it for naval vessels.

In addition to high efficiencies, the catalysts in MCFC are nickel, a cheaper and more abundant metal than Pt, which does not raise costs. It also produces significantly more power than the other fuel cells, average outputs are about 2MW, but 100MW units are being designed.

MCFC have some disadvantages, including the very high temperature operations required to liquefy the solid carbonate salts. The average operating temperatures are about 650°C, which can limit the life of the material due to heat stress. Also the electrolyte is used up when it reaches the anode. To compensate for this CO₂, needs to be injected into the fuel cell.

The use of MCFC did not favorably impact the ship, due to their weight and volume requirements. However the fact that it has such high efficiencies, CO tolerance, and direct reforming capabilities, which might offset the disadvantages and make it a feasible technology. [Ref. 18]

3. Current Uses

Fuel cells are on the verge of changing the world as we know it. They will provide a clean, efficient, and viable source of power with almost unlimited applications. The use of this technology will change the way in which naval vessels will operate. To show this, a few of the many applications for fuel cells will be introduced.

a. Automobiles

The automotive industry is hard at work trying to capitalize on the \$1.2 billion that President Bush has authorized towards the research of hydrogen as an alternative energy. There are several obstacles that the industry must overcome before the cars with this technology can reach full-scale production. First, the fuel cell technology must be cut down in size and price. Additionally, an infrastructure must be developed and expand across the country. There will have to be service centers, as well as fuel replenishment stations spread along every major interstate in order to promote and sustain the use of fuel cell cars.

Leading the way in the fuel cell vehicle industry, Toyota released the first of its test vehicles to the University of California for a 30-month trial. [Ref. 19]



Figure 4. Toyota FCHV-4 (from <http://www.unr.edu/chemengr/che101/fuelcells.htm>)

The engine, as seen in Figure 4, looks much the same as what one would find under any hood. Through the

evaluation and study of this first vehicle, the Toyota Corp. learned more about the technology and the user. The new design by Toyota Corp. is the fuel-cell hybrid vehicle (FCHV), which evolved from the FCHV-4 above.

The [Toyota FCHV](#) represents advancement on the FCHV-4 hydrogen fuel-cell vehicle, which underwent 18 months of real-world testing in California and Japan, logging more than 80,000 miles of evaluation on test tracks and public highways. The vehicle has gone through rigorous crash testing during its pre-market evaluation. During that time the vehicle's hydrogen fuel system has proven to be reliable, durable and user-friendly. [Ref. 20]

The needs and requirements of the user are a big concern, and Toyota will try to meet these needs by adding them to the list of build to requirements. The automotive industry is at the brink of an evolution of unknown proportion, and the technology is finally mature enough to keep up with the market's demands and requirements.

b. Utilities

Fuel cell technology has spurred interest worldwide as a clean form of energy. Energy researchers across the spectrum, from wind power turbines to tidal power machines, are all searching for an efficient, non-polluting, cost effective means to replace or even reduce the world's reliance on conventional combustion powerplants. The current energy research thrust for such a means is fuel cell technology.

The current fuel cell research being investigated by utility companies is in the cogeneration field. The process will be used to create power twice. First, the fuel cell will generate electricity directly from the hydrogen inside. In the next stage, power will be produced

using the heat and water byproducts produced by the fuel cell to power steam turbines. This creates an efficient means of power production.

c. Others

Fuel cell technology is being exploited in perhaps the most unobvious market - the personal computer industry. There are several computer corporations in competitive competition to market the fuel cell technology as a viable and capable technological advance to the PC.

With expected delivery into the market in the 2004 timeframe, NEC Corp. and Toshiba Corp. are pushing the evolution to new limits. The later is using a direct methanol fuel cell (DMFC) as the powering unit. [Ref. 21] The DMFC will plug into the computer in place of the traditional lithium-ion rechargeable battery. The added advancement of fuel cells in markets other than the automotive and utility industries, will promote the continued evolution of the fuel cell technology.

C. INTEGRATED POWER SYSTEM

The IPS will have a vital role in the implementation of fuel cells as the primary power source onboard the surface fleet as mentioned after Figure 1 and also in section E. Also tasked with several additional requirements, the IPS will evolve with time, as will the technologies that it operates with.

1. History

From the time that ships were first introduced to the sea to the present, efficient propulsion has been an important and very critical issue. Propulsion covers technologies that enhance performance such as speed, range,

endurance, and survivability. [Ref. 22] These traits are delivered via powerplants, drive systems, and propulsors. The interconnection of all these systems is what has led to the invention of an integrated power system.

IPS is on the verge of revolutionizing the shipboard power management of the USN. This single integrated electrical power infrastructure will manage and control all ships power requirements. These requirements already include propulsion, ship's service, and basic weapons systems, but with the advance in weapon systems, the power requirements will only increase, and the IPS will be tasked with managing these emerging power requirements.

a. CNO Objective

Aligned with the goals of the DOD for future planning and the types of conflicts that will come, the CNO has set forth a directive that all US Navy ships will be outfitted with IPS as envisioned in the CNO's Sea Power 21/Sea Shield operational concept. The ever-changing battlespace needs the flexibility of the IPS to manage the power flow from basic ship operations to crisis situations. IPS is currently being researched at several locations nation wide. The IPS Program Manager, Mike Collins, leads the way with his research at NAVSEA. Additionally, there have been a few exceptional students at the United States Naval Academy who have found interest in the IPS during their Trident Scholar research.

2. Current Research in Heightened Reliability of IPS

a. Trident Scholars Research

The research done by others is of great value. Our goal is not to reinvent the wheel, rather to join together multiple sources and ideas to formulate a feasible

requirement for the implementation of IPS. The requirement is to design the IPS from the ground up allowing for easy expansion of new technologies and for the IPS specifically, a growing sense of awareness much like artificial intelligence (AI).

(1) Neural Nets. In the research of *Neural Nets* [Ref. 23], exploration of the alteration of control system elements in a less than ideal environment has been investigated. The study focused on the decision-making ability of the control system without perfect input data, which could result from a casualty or catastrophe. It explored the use of estimation algorithms to model the missing data. The research sheds light on the ability of the IPS system to adapt and overcome the loss of various sensor packages. The control element of IPS will be "taught" to differentiate between changes in the physical system and degradations in the sensor package with "proper" training. [Ref. 24] This system will be able to make the correct decision, using AI techniques, by eliminating faulty data and assessing the situation in a logical manner. In effect, it allows the system to solve "what-if" problems and further allows for the advancement of the smart ship movement.

(2) DC Zonal Electrical Distribution System. In the research, *DC Zonal Electrical Distribution System* [Ref. 25] (DC-ZEDS), an analysis of stability in situations of casualty or catastrophe was investigated. The research explores Sudhoff's extensions of the Nyquist stability criteria and time-domain simulation. [Ref. 26] The DC-ZEDS test bed is located at the University of Missouri at Rolla as part of the Energy Systems Analysis Consortium and is funded by the U.S. Navy. [Ref. 27] After

running several trials varying the configurations of the system, one variant was found that seemed to be more stable than the rest. The "second alternate configuration" [Ref. 28] as called, allows for an entire DC bus to be lost and the remaining power supply to be rerouted to a parallel bus for distribution. Such studies as this provide a stepping-stone for the IPS IPT to achieve their goal of a survivable IPS.

(3) Network Fragment Healing. In the research of *Network Fragment Healing* [Ref. 29], exploration of the survivability of IPS communication paths was investigated. The IPS will consist of a series of zones that are to be interconnected with a redundant system of communication paths. The research investigates the zonal controls and their ability to communicate at critical times after casualty or catastrophe. The IPS will have the ability to reroute communications and essentially accomplish network fragment healing in the process. The research is continuing, but there are high hopes that such a robust system will promote a highly survivable network in order to secure communications of the IPS system at all times.

3. The Future Implementation of Research

a. What It Is Attempting to Do?

The goal of IPS is to interconnect a shipboard power grid and allow for better casualty management and a more effective power management.

Currently, warships are built with separate systems to perform different functions, some of which utilize the same resources, see Figure 5. The propulsion

system requires about 90% of the total power, while the electrical generation plant requires the remaining 10%.

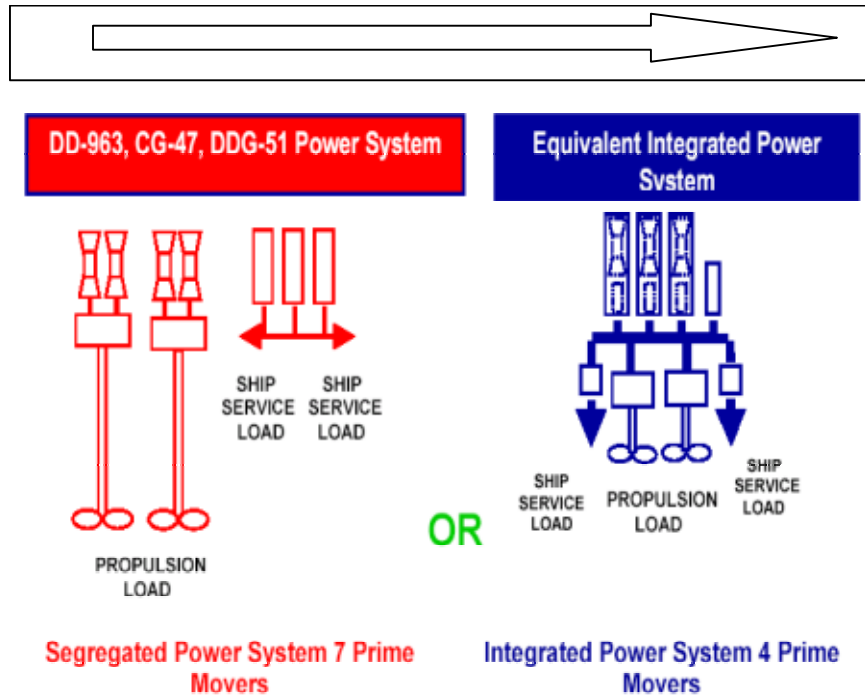

Figure 5. Transformation to IPS (from Zivi, John Hopkins, 1999) [Ref. 30]

Onboard a DDG-51 class destroyer, there are four LM-2500 Gas Turbine Main Engines (GTM's) that are coupled to drive two shafts. Additionally, there are three gas turbine generators (GTG's) that provide the power necessary to operate the ship's service and weapons systems. These two sets of engines, GTM's and GTG's, cannot assist each other in case of casualty or catastrophe, yet both provide power in one way or another. The goal of the IPS is to unite all the power requirements and to delegate resources to each element.

This will allow ships to become more efficient and reliable in the long run. The IPS will have the ability to delegate power flow to critical systems in the event of a casualty. There will be a systems hierarchy divided into zones depending on their critical nature to keep the ship active. The IPS will be capable of managing this hierarchy and promoting stability during unstable times that could arise in combat situations.

b. How It Will Benefit the USN?

The USN will benefit from the implementation of IPS. The system will allow for manpower reduction meeting the goals of Sea Power 21, which calls for a 70% crew size reduction. Furthermore, ships of the 21st Century will be more capable than those of past years. The IPS will be capable of handling all power requirements demanded by the ship.

Figure 1-2. Multi-Layer Control Capability³

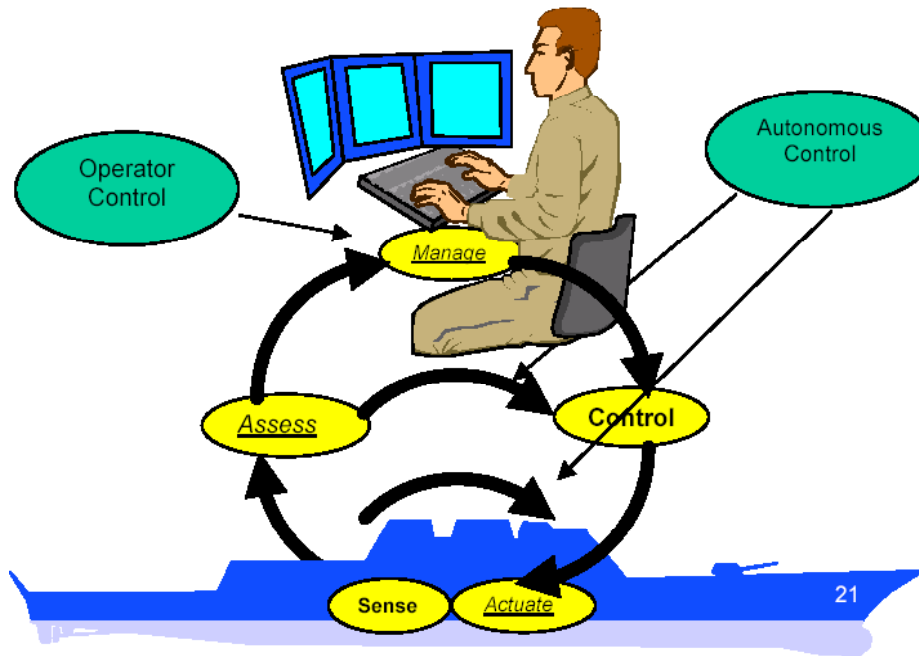

Figure 6. IPS Management (from McCoy, 5th Naval Engineering Conference, 2000) [Ref. 31]

The system will eventually be automated as seen in Figure 6, with only an observer seated at a console monitoring the decisions made by the control system. The console operator will have the ultimate power to overrule any decision made by the machine and the machine will “learn” from its mistakes.

4. The Integration of Fuel Cells with IPS

a. What This Will Allow?

With an impact much like that of the first nuclear powerplant hitting the fleet, the integration of fuel cells with IPS will be a revolutionary change. The combination will provide a versatile platform from which diplomacy can be projected worldwide. Ships will be more capable than ever before, more environmentally sound, more efficient, more effective, and have less total life cycle

costs. An all-electric ship will allow the commander to focus more on mission planning and success, rather than ship constraints.

b. Output Expectations

The IPS is tasked to manage the ships power requirements at all times. The output of fuel cells will be raw power. We expect that the IPS will be able to allocate this power as required. The goal is that the system will be designed to be smart enough to know which systems are critical and will keep them functioning at all times.

In an ideal power system, such as on land, there is an overabundance of power which allows for unlimited current to be delivered to a system. However, onboard a ship, the story is not the same. The current power grid onboard a ship will fault when a load requires more current than the source can provide. The goal of the IPS is to solve and manage this problem.

c. The Evolution of Shipboard Design/Configuration

Shipboard design will evolve to a modular state in the near future. With this evolution comes the ability to add and remove weapon systems and power supplies according to the mission. The vision for fuel cells is to allow modularity. If a ship requires more power due to the addition of weapons systems, there will be expansion slots where modular fuel cells can be added and installed. As the power requirements change, the cells can be removed or added as necessary, meeting the demands. This will be a pier-side operation in the beginning, but there is no reason that it cannot be easily expanded to underway module

replenishment (UNMODREP) at sea. The continuing evolution of the ships of our navy will keep our nation at the forefront of world security.

D. DIRECTED ENERGY WEAPONS

1. Introduction

With the shipboard utilization of fuel cells and IPS, the capability for effective power management will increase aboard naval vessels. With the integration of power production and power management into a single package, more advanced weapon systems can be added. Weapons that would benefit greatly are directed energy weapons (DEW), which require large amounts of power for short periods. Having a power system that can effectively manage this will greatly increase the vessels combat potential.

The utilization of DEW will focus on two different technologies: high-energy laser (HEL) and high-power microwaves (HPM) or ultra wideband systems (UWB). The focus is on modular systems that can be added or removed based on the needs and area of operation of the vessel. Coupling DEW with current kinetic energy weapon systems (KEW) will offer significant advantages over current defensive systems.

a. History

Directed energy weapons are not new. Science fiction has envisioned the use of lasers and ray guns since the birth of the genre. In the late 40's, Navy scientists proposed the use of directed radio waves to defend against atomic weapons. [Ref. 32]

Since the discovery of lasers in the 1950's, their military applications have been investigated. In the

60's and 70's, there was significant funding for the use of laser technology in support of military operations. The development and use of lasers can be seen in all the major DOD sensors, weapons, and information systems. This technology has become an integral part of DOD and its future uses seem very promising.

As with lasers, the use of radio frequencies (RF) as a potential weapon has been investigated extensively by the military. It was not until large scale testing of the atomic bomb after World War II, that the disruptive effects of electro-magnetic (EM) radiation were understood. During nuclear testing, it was discovered that electrical equipment was disrupted by the EM radiation released during the explosions. A significant amount of funding has gone into this investigation and as of now, this technology is closer to being used as a defensive weapon than HEL.

2. Lasers

The use of lasers for fleet defense is not a new concept, but until recently the use of this technology was not feasible. Through the past half-century in which the laser has evolved, it has become more compact and more powerful than ever imagined. Combinations of these two traits make it a viable technology capable of protecting the fleet against enemy threats.

a. How They Work?

The **L**ight **A**mplification by the **S**imulated **E**mission of **R**adiation (LASER) is a commonly used and well-understood technology. In the simplest terms, a laser is a monochromatic, condensed, and directional form of light.

A laser is a very coherent beam of light that is produced by exciting electrons within a lasing material^b. The electrons within the lasing material are pumped or excited and raised into higher energy states, which are more unstable^c than the ground state. The excited electrons, desiring to become more stable and return to the ground state, release their energy in the form of photons.

As the material is excited, a population inversion occurs between the energy states. A population inversion occurs when the excited electron states become more highly populated than the ground state.

To get full power from a laser, it has been designed to produce stimulated emissions. Stimulated emissions occur when the released photons, having a certain phase and energy, collide with one another. The first photon can then stimulate other photons, which take on the same frequency and direction as the original photon. Mirrors are placed at both ends of the lasing material to increase the propagation effects. As the photons move back and forth along the material, more and more stimulated emissions occur. As a large degree of photons become stimulated, they are eventually ejected from the lasing material in the form of a laser. Figure 7 shows how the electrons are converted into a laser.

A laser is more powerful than an incandescent light bulb. This results from the fact that light is not randomized but focused, increasing the intensity. The

^b The lasing material is similar to a light bulb filament. As energy is added to the lasing material, electrons are excited to a higher energy level.

^c The material is usually pumped using high voltages or intense flashes of light.

focusing and intensity of the laser allows more energy to be deposited on a target, causing damage or destruction.

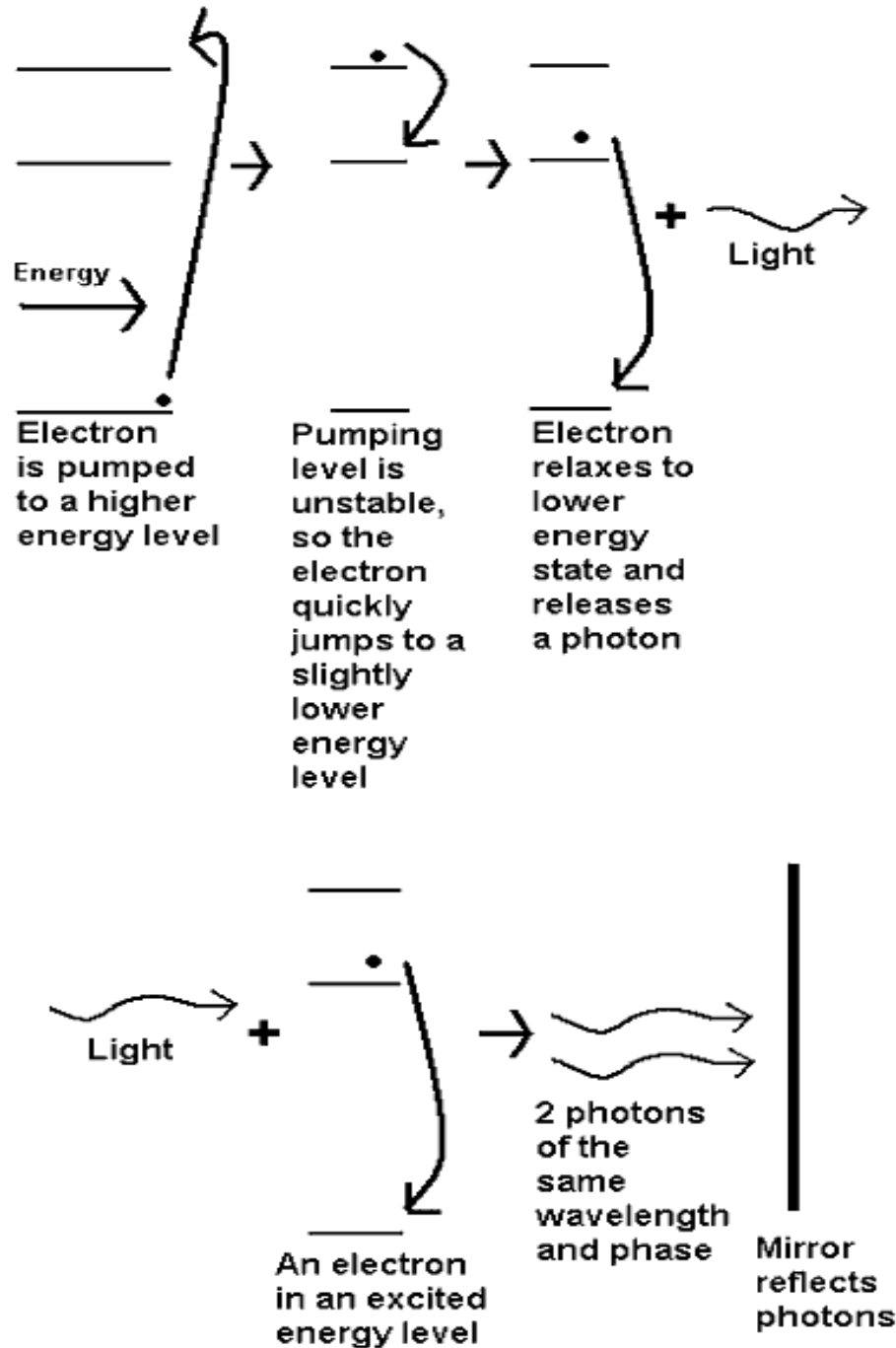

Figure 7. Stimulated Emissions to Produce Lasers (from <http://science.howstuffworks.com/laser2.htm>)

b. Laser Types

All lasers work using the principles described in the previous section. However, there is more than one method to excite the lasing material. The main types of lasers being investigated for shipboard defense are as follows: gas-dynamic, electrically-excited, chemical, and the free electron laser (FEL). Each laser has its own advantages and disadvantages.

(1) Gas-Dynamic Laser. In a gas-dynamic laser, hot gases or exhaust from spent fuel is released onto a lasing material through nozzles at vacuum conditions. Most gas-dynamic lasers use CO_2 , which produces a laser in the far infrared. Gas-dynamic lasers require a significant amount of equipment for operation, and this translates into a system that is bulky, complex, and expensive. [Ref. 33] Their usefulness is still being investigated.

(2) Electrically-Excited Laser. The electrically-excited laser uses electricity to pass a current through laser gas. The energy is then transferred to the lasing material, producing the laser. The use of electrically-excited lasers can be very efficient, however the use of a power source adds inefficiency to the system. [Ref. 34] The two types of lasers: CO_2 and CO , can create strong lasers, however the CO laser operates at a temperature of -173°C . The main advantage of this type of laser is the fact that the ship can easily produce electricity.

(3) Chemical Laser. In chemical lasers, two or more chemicals combine to produce excited molecules, for the production of a laser. The most promising chemical laser is deuterium fluoride (DF). These lasers replace the

^1H (hydrogen) isotope is with the ^2H (deuterium) isotope, producing a wavelength that is less susceptible to atmospheric interference resulting in less breakdown of the laser beam. The major problem with the chemical laser is the fact that a large amount of fuel is consumed. The D and F atoms are very reactive and require space to store them, which is limited onboard the ship.

(4) Free-Electron Laser. The free electron laser (FEL) is a promising technology that will be very important to the introduction of DEW. This laser uses a relativistic electron beam as the lasing material, instead of bound atoms. It has the same characteristics of a conventional laser, with a high power output and the ability to tune to the required wavelength as needed (from millimeter to x-ray in the future).

c. Mirrors and Targeting Systems

A very important but difficult technology that needs to be developed is the series of mirrors that will be needed to focus the HEL's. These mirrors must be able to focus and adjust to the targeting system tracking element in order to strike an incoming target. They must also be small enough to be implemented aboard ship and respond to the atmospheric conditions. This might require the use of adaptive optics, which is a very complex technology that can distort the reflective surface so as to get optimum focusing in given atmospheric conditions.

In addition to the series of mirrors, the targeting systems needed to detect, engage, track, and evaluate the success or failure of the laser must be further developed. This will require computer intense systems with complex algorithms and the ability to rapidly

process data. The faster the data is processed, the quicker the target is identified, and the more likely the system will be successful.

d. Laser Damage

In order to investigate the damage potential of one of the above laser technologies, a measure was defined. Fluence, the amount of incidental damage per unit of area (joules/cm²), is a measure of how effective a beam weapon will be against a given target. The factors that can improve the fluence of a laser are: the diameter of mirror, the output power of the laser, and the exposure time. [Ref. 35]

e. Advantages

The use of lasers for fleet defense is a very viable alternative to the current defensive weapon systems. In order to maximize the potential of the technology, the laser will have to continue to evolve through advanced researched and modernized engineered practices.

The laser has the same goal as KEW- it attempts to destroy or neutralize an incoming threat. One of the advantages is the fact that the laser travels at the speed of light. Instead of having to launch a missile and let it get up to speed, the laser can be fired and reach the target instantaneously. This allows for engagement of the target much quicker and further away from the ship. This in turn means that survivability of the ship will increase because more engagements should occur before the threat reaches the ship.

The laser can be fired as a series of pulses or as a continuous beam depending on how much energy is needed to destroy the threat. There are two ways in which a laser

can neutralize a target: by destroying the target physically or by causing enough damage to the sensors to render the weapon inoperable. First, to physically damage the target, a large amount of energy is deposited on the target in effect causing the metal to reach its melting point and liquefy. The goal of this neutralization method is to sufficiently disable the target so that it either self-destructs or aerodynamically cannot fly and crashes. The other neutralization option is to attack the sensor package directly. In this case, the targeting sensors are overloaded with energy. This overload can cause disruption and power spikes within the sensor elements effectively shorting out the control circuit. Two crucial sensors that can be targeted are the navigation/GPS package and the flight control package. It might not be a direct kill, but rather put the weapon systems out commission and cause an eventually mission failure.

f. Disadvantages

There are many advantages to using a laser; however, there are also significant disadvantages to using such a system. The most significant of these is the fact that the proposed system will operate within the restraints of the atmosphere. The major constraints that the atmosphere put on a laser system are absorption, scattering, and thermal blooming.

With absorption, the laser emits specific wavelengths that can be absorbed by the clouds, water vapor, and other atmospheric elements. The absorption by the atoms and molecules of the atmosphere can be modeled as and I^2R power loss. Once this energy is absorbed, it is lost forever for all intensive purposes. This severely

constrains the range of wavelengths that can be used and in turn results that only certain types of lasers can be used.

Scattering is the phenomenon in which light spreads out causing the coherent nature of the laser to become divergent. This again is a function of the atmospheric conditions. Another common type of scattering is spreading loss or as it is often referred to, Free-space loss. This constrains the electromagnetic wave and depends on distance. Scattering effects can vary from day to day and depend greatly on the location, and time of day. All these factors must be considered to create an ideal environment for the use of lasers with minimized scattering effects.

Similar to spreading, thermal blooming is another constraint on high-energy waves traveling through the atmosphere. The lasers energy is transferred to the surrounding air molecules, creating a spreading of the laser. Thermal blooming is a major factor when measuring the efficiency of the laser and its ability to engage targets.

In addition to the atmospheric problems, the laser systems will have to be small enough to fit on a shipboard platform. As of right now, there are major size restraints that limit the size and power of the lasers that might be used. As the technology continues to evolve and becomes more mature, this problem will become trivial.

3. High Power Microwave and Ultra Wideband Systems

The aims of high-powered microwaves (HPM) and ultra wideband (UWB) systems are similar to that of the HEL and

kinetic weapon systems aforementioned. However, the way in which they are implemented is different. This section will discuss the basic principles of this technology and how it might be used for shipboard defense.

a. How They Work?

The most fundamental principle of HPM and UWB systems is the fact that they use electro-magnetic (EM) radiation. HPM systems use narrow bandwidths and large pulse widths, while UWB have large bandwidths and very narrow pulse widths. This allows for the addition of unique weapons to be used for fleet defense.

(1) Disruptive Effects. HPM and UWB systems have different ways in which they destroy incoming threats, but their disruptive effects are the same.

When the threat experiences an *upset*, the normal operations of the electrical equipment onboard the threat are altered, such as the sensor package. An upset occurs as long as the radiating source is operating, and electrical systems return to normal after the radiating source is turned off.

A *lock-up* occurs when the radiating source causes a temporary interruption of normal operations. However, when the radiating source is removed, the threats electrical equipment needs to be reset. This can cause significant problems to a self-guided weapon, but less to a manned threat. A more severe form of lock-up is referred to as *latch-up*. This occurs when the radiating source causes electrical equipment (circuits) to be destroyed.

With *damage*, burnout of electrical junctions occurs. Damage is a measure of the permanent destruction done to the electrical equipment onboard the target. With most unmanned and manned threats, loss of the electrical

equipment would mean that the system could no longer function properly. Damage is most commonly associated with high-powered RF devices that seek to destroy targets.

(2) Pathways of Attack. The RF weaponry is very powerful and possesses two distinct pathways of attack. HPM and UWB radiation can cause damage to a target via front-door intrusion or back-door influence. RF weapons do not directly attack the targets; rather they exploit flaws in design of the threat.

With *front-door* attacks the RF weapons direct their attacks towards the threat's antenna. This is done because relatively weak signal returns are expected according to design. By introducing unexpected high-energy returns produced by the HPM or UWB devices, the RF weapons can have a significant impact. If the radiation is powerful, varying amounts of damage can be caused to the system, severely degrading the enemy's capabilities. However, one problem that arises with this is that the frequency range of the microwave weapon must be within that of the antennas. This means that a significant understanding of the enemy systems is required to defeat such a threat.

Back-door attacks exploit the fact that all weapon systems have flaws. With these types of attacks, the microwave energy is directed towards paths other than the antenna. It focuses on the airframe's cracks, gaps, absorbent/conductive materials, wires, etc... All of which can be used to reach the internal electrical components. The only way to defeat this type of attack is to have a perfect system - free of errors.

b. What They Will Require?

The HPM and UWB systems are just like any other system in the DOD inventory. They are relatively mature technologies that has been researched and improved over the last 50 years. With this evolution, the implementation of microwave weapons for shipboard self-defense is a feasible technology that has the possibility to prevent damage to high value assets that could be considered viable targets by our ever-morphing enemy.

In order to implement this technology, a few requirements are necessary. A typical system will need a power source, a RF generator, and an antenna. A control system will allow all of the requirements to be maintained and managed. The power source for this type of system will be part of the ships power grid, which will eventually include fuel cells as prime movers. The control system will be within the IPS.

The RF generator is the source of the microwave radiation. It works by converting the kinetic energy of an electron beam into the electromagnetic energy of a microwave beam. [Ref. 36] Both HPM and UWB generators produce frequencies between 10 - 100 GHz, with power levels ranging from 100 MW - 100 GW. Most HPM systems have large pulse widths of 100 μ s and use 1% of the frequency, while UWB systems have narrow pulse widths of less than 100 ns and up to 50% of the center frequency. [Ref. 37] The generators produce narrow and wideband radiation that yields multiple simultaneous frequencies. [Ref.38] Using both high and low energy fluences, microwaves can be produced to destroy enemy threats.

After creation of the microwaves, an antenna is needed to steer the energy to the threat. With the use of UWB systems, a lot of energy is needed to deliver a large range of frequencies, which allows for less precise targeting of the threat. On the other hand, with HPM systems, either a mechanically steered antenna or phased array can be used to deliver the microwaves to the target. HPM beams will need to be steered more accurately, due to the narrower beam; therefore they will need a more accurate targeting system.

c. Characteristics

The use of HPM and UWB systems for fleet defense is promising. With this comes the fact that unlike kinetic energy weapons, the RF weapons will continue to fire as long as there is a power source available. With the implementation of the IPS to manage power generated from fuel cells, new vessels will not have to consider power as a system constraint to the degree in which it was considered in the past. This weapon will be able to travel at the speed of light and fire either pulsed or continuous burst of high-energy microwaves. They will be able to reach the target instantaneously and begin to degrade the performance of the threat.

As seen with the use of microwave systems, the damage they cause can be both temporarily and lasting. They can both damage and destroy, resulting in effects that can severely degrade the enemy threat. RF radiation with a high fluence can be used to destroy enemy electrical equipment that is both turned off and on and thus, limiting its future effectiveness or use. Extremely high fluences could possibly detonate warheads, resulting in certain

destruction of the airframe that is being used to carry the warhead. While at lower fluences, semiconductors tend to overheat causing temporary or permanent damage to vital control systems.

The HPM and UWB systems have very different characteristics. The HPM has a longer pulse width, however it uses a narrower bandwidth. This means that steering of the beam must be more accurate, however it requires less power to cause damage. Trying to destroy a target using HPM requires intelligent information about the enemy's operating frequencies in order to defeat the threat.

The UWB system has a shorter pulse-width, but a much larger bandwidth. A multitude of frequencies are used to try to neutralize the enemy threat. To accomplish this, more energy is needed to operate the system; however, in return less accurate targeting systems are needed because UWB has a larger coverage area.

Finally, like the HEL systems, the atmosphere has a noteworthy effect on the performance of the HPM and UWB systems. The effectiveness of microwave weapons is limited by the beams ability to operate within the atmosphere. The propagation is limited by dielectric breakdown, diffraction, and attenuation, which depend on the intensity, frequency, and pulse width [Ref. 39] of the beam. The atmosphere offers a significant challenge to the operation and thus implementation of DEW.

III.COMMAND AND CONTROL IMPLICATIONS

A. INTRODUCTION

Through the implementation of new technologies, new challenges arise in the C2 field. The following chapter seeks to bring light on several interesting topics that must be discussed before the technologies can be implemented. The goal is to hypothesize the potential problems, as well as the added benefits that the systems will face on the near-term and far-term destroyer platforms. There will always be uncertainty and unknowns when dealing with new and emerging technologies, but the desire is to identify the factors that will result from the implementation of these new technologies.

1. Near-Term Destroyer (5 to 10 Years)

The DOD has strong support from the POTUS as well as the Congress. Both the executive and legislative branches have approved the following directives as a necessity in all newly acquired naval ships based on the need for standardized technology:

- Fuel Cells
- Integrated Power System
- Modularity

The technologies aforementioned have been tested in various simulations and proto-types at the Office of Naval Research (ONR) and in the private sector. They have proven themselves to be very useful tools for advancing the surface fleet, furthermore allowing commanders a greater degree of control as well as more operational maneuverability.

a. C2 Integration Expectations

As new technologies are introduced to the fleet, they must be backwards compatible in order to ease the integration process. The challenge arises with the implementation of new, more advanced technologies with the expectation that they will work alongside the older technologies already onboard. This issue will be solved through standardization of system architecture requirements before the components are engineered.

This will require the near-term destroyer to be built from a seaworthy shell, adding the components and systems as necessary to complete the near-term design. Ultimately, a new hull design could be implemented using the same technologies used in the previous shell. An important factor to consider is that the hull and the technology itself are completely independent challenges. The Navy will prove the technology at sea before it is implemented on the new hull design. The process of installing the sea proven technology on the near-term destroyer hull will be trivial.

Additionally, the IPS will be a programmable power grid that can be upgraded with new software as potential problems arise. The ultimate goal of the IPS is to be capable of meeting the integration challenges presented by new technologies. The IPS will be capable of routing power to meet the addition of more modules as they are added to the ship, whether they are power sources or weapon systems. This feature will allow for an easy integration to the far-term destroyer.

b. Fuel Cell C2 Expectations

The transformation from the current mechanical powerplants^d to the future electrochemical powerplants is going to have dramatic effects. These effects will range from an increase in sailor personal space to reduced crew manning and smaller engineering spaces to a more modular ship.

The introduction of fuel cells as a primary power source onboard naval vessel will not change the average sailor's life; however, it will change the amount of personnel space they have. Currently, the average sailor sleeps in a berthing that is 20 inches from the mattress to the overhead panel above. [Ref. 40] Since fuel cells do not require the extensive mechanical support systems of previous powerplants, the engineering spaces will be dramatically smaller. With the overall size of the ship staying relatively the same, there will be an increase the habitable space for each sailor. This should help sustain morale for the longer deployments that are expected in the future as well as creating a more sailor friendly environment to work in. Also, Sea Power 21, which calls for a reduction of manning, will reduce the overall ships company and thus increase the berthing area. The individual sailor will benefit from these alterations.

An additional benefit that will be seen after the implementation of the fuel cells will be a reduction in overall maintenance of the ship, as there will be less moving parts and smaller engineering spaces. This will

^d The current powerplants are either diesel or gas turbine driven.

allow more focus to be placed on the mission at hand, instead of internal failures of systems.^e

Fuel cells will be able to convert existing marine fuels into hydrogen, necessary for power production. There will a continued dependence upon marine fuels due to the flammable nature of hydrogen gas and the hazards that it poses of naval vessels. This means that continued research to develop low impurity fuels will be necessary to get the highest outputs from the fuel cells. A reliance on supply vessels will be necessary to ensure operational maneuverability.

The modular ship concept is one in which systems can be added and removed depending on the mission requirements. As stated by the acting Secretary of the Navy, "Ships will essentially be Plug and Play."^f This capability seeks to increase the combat potential of the ship by allowing the commander to add the required modules for each particular mission. The commander is better able to deal with scenario knowing that the right systems are onboard. Fuel cells offer a great advantage because they are self-contained systems, making them easily transportable and modular. This will ensure that all power requirements are met throughout the mission.

These few benefits should come with the implementation of fuel cells on the near-term destroyer. They are but a small stepping-stone towards the continuation of superiority among our naval forces.

^e The fuel cells have a high reliability as mentioned previously.

^f Honorable Mr. Johnson stated in his address to the student body at the Naval Post Graduate School on 16MAY03.

c. IPS C2 Expectations

With the implementation of new and emerging technologies such as fuel cells onboard the near-term destroyer, there will be many challenges that arise. The expectation of IPS is to make critical decisions in regards to power management. This includes the strict allocation of power to critical systems during power deficits, and to restore power to other systems as power availability increases. Basically, the IPS is tasked to manage the ships power requirements at all times. The combination of the durable IPS with the power generation of modular fuel cells allows electric drive to be a feasible reality.

With the introduction of IPS, electric drive propulsion will become a reality providing an improvement over the reduction gear driven shafts on past destroyers. The use of electric motors to control the variable pitch propellers is much lighter and makes for a more maneuverable vessel. With more weight requirements relieved, powerplants can be placed anywhere throughout the ship. The overall survivability of the ship will increase because the powerplant cannot be targeted directly.

d. C2 Modularity Benefits

The modular design will allow for systems that can be installed and used almost immediately. The design, currently aimed towards the surface navy, will be easily scaleable and adaptable to any ships of the fleet for near-term implementation. The modularity design has great potential for the future destroyer fleet. For example, if a destroyer needs a certain amount of power for all ships systems, then the number of fuel cell power units will be installed to meet the demand. The added power potential

will be routed into the IPS for distribution and will be discussed in detail in a latter section. However, if a new weapon system is added to the inventory, then additional fuel cells can be added to meet the increased power requirement. Once more, the scaleable, modular design mentioned above is the perfect replacement for the ever complicated and problematic three phase, 450 volt ac, 60 Hz Generation and Distribution System [Ref. 41] found on the DDG-51 Class. The modular design continues to tackle the ever-demanding shipboard power requirements.

B. FAR-TERM DESTROYER (20 TO 30 YEARS)

With the successful fielding of the near-term destroyer, several sea trials have proven the combat effectiveness of the new technologies including fuel cells and the integrated power system. This success resulted in Congressional authorization for continued funding of the program into future fiscal years. Along with shipbuilding funds, more research and development funding has been appropriated for technological improvements to increase the ships endurance, its survivability, and crew/shipboard habitability.

The development of future combat vessels will focus on more automated systems and a higher degree of survivability. This push is in response to the increasing ease in which nation-states and terrorist organizations, can acquire highly sophisticated weapon systems. These systems are becoming easier to operate, more complex, and less expensive. As a result, naval vessels operating in the vast littoral regions of the world are more likely to be threatened by such systems. The high value assets must

be protected by either repelling such attacks or by minimizing the damage that such attacks cause.

1. Directed Energy Weapons (DEW)

Along these lines, the Missile Defense Agency (MDA) has requested Navy assistance on testing a seaborne variant of their DEW missile defense system. The Navy, with contractor support, has determined that the best way to do this is to retrofit a system on an older variant of the near-term destroyer discussed earlier. An older ship will be placed in the shipyard to undergo upgrades. These upgrades will include a more efficient and higher powered modular fuel cell powerplant. In addition the latest advances to the IPS will be retrofitted with the upgrade.

The DEW modules added to near-term destroyer will complement the defensive kinetic energy weapons (KEW) already employed on the ship. The upgraded DEW package will include the following: a high-energy laser and high-powered microwave system for close to far-range engagements. Together these weapons will be used to destroy enemy missiles, aircraft, and small surface craft.

The HEL and HPM modules will be integrated (KEW systems already in place) with the ships C2 suites, leading to manual or auto engagement of enemy targets. A combination and integration of all systems will result in a very versatile vessel capable of dealing with most threats that it will face.

2. Battlespace Commander Influence

During Operation Iraqi Freedom, the Iraqis launched Scud missiles against the populace of Kuwait. Fortunately, the Patriot missile batteries were able to intercept these missiles. Transferring this thought to a fleet of high

asset ships, a missile carrying conventional or nuclear, biological, or chemical (NBC) warheads could result in significant damage to the fleet. This could give the enemy both a military and moral victory.

With the implementation of a DEW system, the engagement of enemy threats could occur at greater distances from the vessel. This longer range means that the likelihood of successful destruction of threats will only increase. If the battlespace commander could focus on mission success, and not have to worry as much about the defense of the ship, then more time could be spent on command of the vessel and the current missions.

3. Implementation Options

a. What It Offers

The US Navy has gone through many transitions throughout its history. In years past, the main objective of the US fleet was domination in blue-water confrontations. However, the focus has shifted to the brown-water or littoral regions of the world. These regions offer significant threats to the survivability of a high-asset fleet that were not previously considered.

The implementation of DEW in support of fleet defense will offer significant advantages to the battlespace commander. The transition from the kinetic weapons of the past, to DEW of today will change naval tactics as fundamentally as from sail to steam. [Ref. 42] The implementation of this technology will shift the role of the carrier battle group operations from massed, attrition-oriented defense, to a more dynamic, dispersed offense. [Ref. 43]

b. Types of Systems That Will Be Implemented

There are four implementation options for a future defensive DEW system: HEL only, HPM/UWB only, a combination of HEL and HPM/UWB, or a combination of HEL, HPM/UWB, and kinetic energy weapons. Each particular technology offers both advantages and disadvantages as seen in the earlier chapters.

The use of only one weapon system, HEL or HPM/UWB, would offer serious disadvantages to shipboard defense. Thus, relying on only one technology is not a very wise decision. It could lead to grave death and destruction resulting from a single failure of the system to intercept their targets. The threats to high value targets, like destroyers and aircraft carriers, are very real. This weapon alone could not be allowed to fail, because that would be the only defense for the ship.

The ocean environment is very hazardous. HPM and HEL systems cannot function properly when the weather is less than perfect. Relying on systems that can operate in only certain perfect atmospheric conditions is a risky gamble. Defensive systems must be able to defend against threats of all types and at all times. By using only one system it would not possible to cover all the angles.

The best way to implement DEW technologies is to develop an integrated system that include HEL, HPM/UWB, and kinetic weapon systems. The HEL portion of the system would provide for far-out ship defense. HPM/UWB suites would provide mid-range defensive coverage. The kinetic systems would be able to cover all levels, but would focus on close-in engagements. The coalition of these weapon

systems will allow for a tiered shipboard defense and will provide for maximum shipboard survivability.

c. How the Systems Will Be Implemented

Implementation of the systems will require ships that are capable of accepting new technologies. One prospect is to create system packages that could be universally adapted to meet the objectives of a particular platform. If a ship is going to operate in blue water, then it will not need extensive DEW systems. However, if the same ship were called upon to operate in brown water areas, then a DEW suite would be required. This brings about the ever-tiring question to the scheduling department of the Navy, how much is enough to be deployed with? The simplest answer is that a collection of modular suites must be fielded so that the abilities can be added as needed.

These suites would include HEL, HPM/UWB, and kinetic weapons, and would provide complete and all weather defensive capabilities. They would be completely modular, having the ability to integrate into the IPS already onboard.

The modular systems would be able to meet the requirements of the ship in whatever operating environment they were required to perform their missions. This would provide an increased operational maneuverability and increased ship survivability.

4. DEW and the C2 Process

The introduction of DEW to supplement shipboard defense will not have a drastic impact to the command and control process. The use of lasers for engagement of threats will follow a similar process to that used on today's warships. The DEW will be used in defense of the

ship in the same manner as the current kinetic energy weapon systems. DEW will be constrained to operate in the same environment as current weapon systems and thus, they will have similar limitations and benefits.

All weapon systems since the Cold War have an element of autonomous control. This is the ability for a weapon system to detect, track, identify, and fire on all possible threats in the event of total war. Preparing for a possible war with the Soviet's, American system engineers designed systems to be capable of handling themselves and protecting our assets.

This being said, the missile systems have three different modes of operations. The fully automatic mode operates in such a way as to detect and fire on all targets deemed hostile. A lesser variation is semi-automatic mode, in which the system identifies and targets the threat, without firing the weapon. The firing process is left to the decision maker, most likely the CO or TAO. The final variation is the manual mode. This mode allows the decision maker to be involved in all of the processes. Additionally, the decision maker identifies targets as hostile, friendly, or neutral. Ultimately, the decision maker is involved at every step of the process in the manual mode of operation.

Since autonomous modes of operation are generally not used, it is up to the decision maker, not the computer, to determine how to handle enemy threats. There are C2 tools such as Boyd's OODA loop that help aid in the decision making process, yet these are only tools. They cannot make the time critical decisions necessary for the ship's defense. As technology advances and the face of warfare

changes, decision makers will be forced to make difficult decisions all the same. With the three modes of operation still present in newly acquired technologies, it will still be up to the human to determine the best course of action. Having a human in the loop is both a limitation and a benefit. The limitation comes in the fact that the human might not be able to make the right decision fast enough with multiple threats as would happen in a total war. Additionally, the computer never sleeps or becomes sleep deprived as a human, thus the actual human operator is a limitation in itself. On the other hand, it is an advantage to have a human in the loop, because they have experience and are ultimately responsible for the outcome.

There are no perfect weapon systems or modes of operation, and no perfect decisions or decision makers. Systems are designed to protect the assets at risk. The decision makers are taught the skills and have the personnel experience to drive their decisions. Adding new technologies such as DEW will not change the process of war-fighting. The new technologies will not make better decisions; rather they will give the decision maker more options in an attempt to better control the battlespace environment.

C. ORGANIZATIONAL STRUCTURE

Effective command and control is achieved through proper management of the organizational structure. As the past has proven, the introduction of new technologies does not change the overall organizational structure. Therefore, no monumental changes are expected to occur with the introduction of the near-term and far-term destroyers

to the fleet. However, the internal command relationship will alter slightly as new divisions are added and others are realigned to meet the requirements.

1. NEAR-TERM DESTROYER

With the implementation of fuel cells and the integrated power system, the ships engineering organization will be altered to accommodate the new technologies. The chief engineer (CHENG) will be responsible for the overall operation of the engineering spaces, and will report directly to the commanding officer. The CHENG will be responsible for the operation of the fuel cells and making sure that the IPS is properly functioning. Instead of being concerned with the large mechanical systems currently used for ships propulsion, the concern will be to oversee and manage the divisions under the CHENG's control. The CHENG will have two new and very important divisions: Fuel Cell (FC) division and IPS division.

The FC division will report directly to the CHENG and will be responsible for keeping the fuel cell power generation system operational and online at all times. Their primary role will be to monitor the system and keep all sub-systems in check, while providing continuous uninterrupted power to the IPS. Additionally, the FC division officer will be in charge of fuel management and will be required to maintain a readiness factor according to doctrine.

Another critical division under the control of the CHENG will be the IPS division. This division will be tasked with routine operation and maintenance of the IPS. Additionally, they will be required to oversee the semi-autonomous operations of the IPS. There will be an IPS

watch officer in charge of monitoring the system. The IPS will draw its power directly from the fuel cells, and thus there will be an open channel of communication between the two divisions. Working together, these two divisions will be able to generate and route power to the necessary systems in a time critical environment.

2. Far-Term Destroyer

With the implementation of directed energy weapons, there will be significant hardware and software obstacles to overcome as well as organization challenges. The most significant change that will result from the introduction of DEW is the fact that large amounts of power will be required for short periods of time. These massive power requirements will come when they are called upon to fire either the laser or microwave systems. The IPS will be responsible for the management and allocation of power to the weapon systems, while ensuring that the mission essential systems remain in operation.

A new position will be created, the defensive system officer (DSO), who reports to the CO on all matters concerning DEW. The DSO will ensure that the DEW and IPS operate together, allowing effective utilization of the DEW. The DSO will be able to use the both the engineering and combat systems departments to achieve this goal. It will be the responsibility of the engineering department to ensure that the IPS is properly functioning and provide the necessary power to the DEW. Combat systems will ensure that the DEW systems are in good working order and functioning properly.

By creating the position of DSO, a specialist will be on hand to address any issues about this complicated

weapons systems. This will allow the CO to effectively utilize the DEW system in defense of the ship.

3. Possible Structure Changes

With the implementation of new technologies, the roles within the organizational structure of the ship will change to maximize its combat potential. The organizational structure will be similar to that of the current destroyer as seen in Figure 8. The following descriptions will be the author's interpretations of how each role of the structural chart will change with the implementation of new technologies in the future.

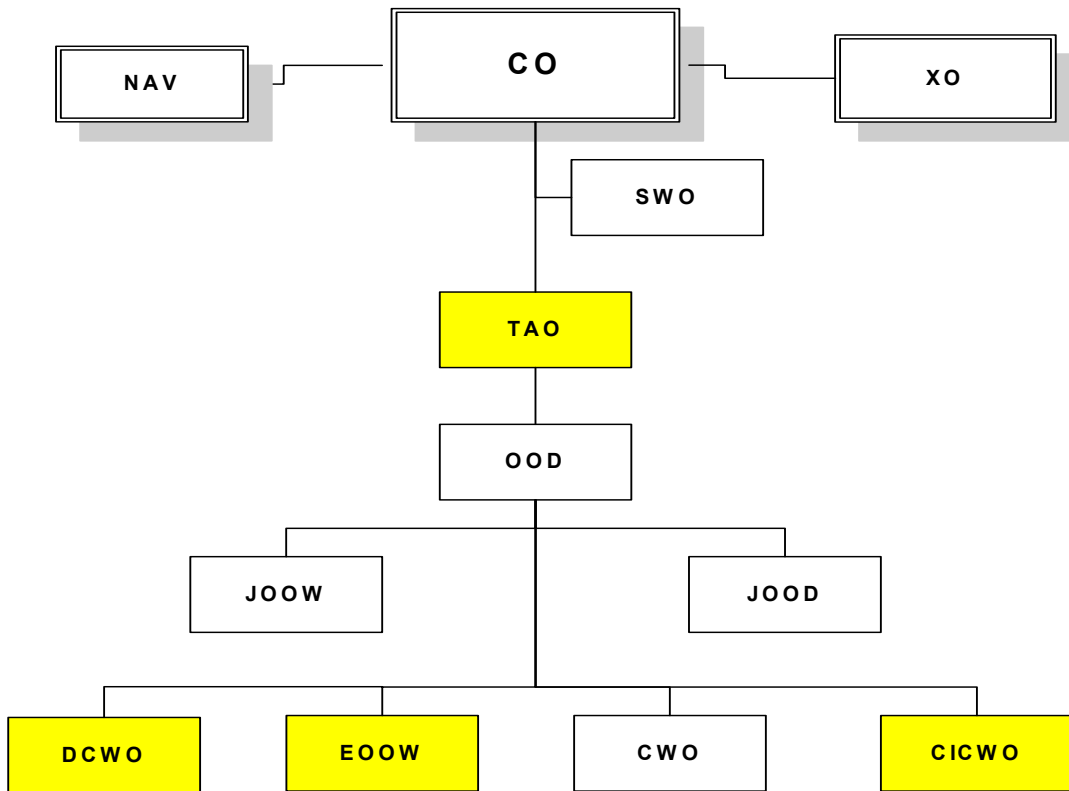

Figure 8. Underway Organizational Structure [Ref. 44]

- **Commanding Officer (CO):** The CO has overall responsibility for the ship. This role will not change with the introduction of new technologies;

however, the CO will have the ability to better defend the ship with more capable weapon systems.

- **Executive Officer (XO):** The XO is the second in command of the ship and is responsible for the administrative side of the command. This role will not change with the introduction of new technologies.
- **Navigator (NAV):** The NAV is responsible, under the CO, for the safe navigation and piloting of the vessel. The NAV's role will not change with the implementation of new technologies.
- **Senior Watch Officer (SWO):** The SWO is responsible for the assignment and supervision of all watch standers. The SWO keeps an up to date log of all qualifications held by the watch standers. New watches will come about with the implementation of new technologies; however, the process of manning the watch will remain the same.
- **Tactical Action Officer (TAO):** The TAO is responsible for the defense of the ship during wartime steaming or times of crisis. It is the TAO's responsibility for tactical employment of the ship's weapons systems. The role of the TAO will change significantly due to the introduction of new weapon systems. The TAO will be responsible to learn the capabilities and limitations of these new systems and determine how to properly employ them. Thus, the weapons with which the TAO fights to defend the ship will be different.
- **Officer of the Deck (OOD):** The OOD is responsible for the safe navigation of the ship and must report all variations from the CO's standing orders. The role of the OOD will not change from the implementation of new technologies.
- **Junior Officer of the Watch (JOOW):** The JOOW is the OOD's assistant and is often responsible for conning the ship. The JOOW is in training to become OOD qualified and the role will not change with the implementation of new technologies.

- **Junior Officer Of the Deck (JOOD):** The JOOD is usually delegated to be the conning officer by the OOD. As the conning officer, the role is to direct the movement of the ship with rudder and engine orders. Future technologies may allow for the use of vocal commands to conn the ship and even with the implementation of electric drive systems, the process that the JOOD uses to conn the ship will remain the same.
- **Damage Control Watch Officer (DCWO):** The responsibility of the DCWO will remain critical to the operation of the ship. With the implementation of new technologies, new potential problems arise. The introduction of fuel cells as a power source will require quick response, due to the possible escape of hydrogen that could start massive fires instantly. The IPS will be designed to control the power fluctuations and spikes, but with the massive electrical loads possible class Charlie fires may arise. The actual role of DCWO will not change; however, the process with which the job is done will have many more considerations.
- **Engineering Office Of the Watch (EOOW):** The responsibility of the EOOW is to ensure the safe operation of the ship's engineering plant. This role will remain much the same, with the exception that the location and size of engineering spaces will change. The large engineering spaces as we know them today will be gone, as the powerplant will be fuel cell operated. The EOOW will be responsible to learn about the possibilities and limitations of the new technologies.
- **Combat Systems Watch Officer (CICWO):** The CICWO is responsible for the supervision of the combat information center (CIC) and its personnel. The CICWO is also responsible for making recommendations, to the OOD allowing safe navigation of the vessel. With the introduction of new technologies, the CIC will be dramatically different from those of today. This means that the CICWO will have to learn how to manage entirely new systems and the personnel required to operate them.

- **Communications Watch Officer (CWO):** The CWO is responsible for keeping the communication elements operational at all times and to constantly monitor channels to prevent avoidable blackouts. As new technologies arise, there may be new interfaces implemented shipboard, but the overall job of the CWO will remain the same.

The implementation of new and emerging technologies will present a challenge to many elements of the organizational structure. It is the opinion of the authors that the roles that will see the most change will be the TAO, DCWO, EOOW, and the CICWO. With these few changes, all roles will alter because of the consideration of new technologies; however, the basic command structure of the ship will remain the same.

4. Operational Combat Environment

The operational combat environment will be much different on future variants of destroyers. With the ever evolving threats that our asymmetric enemies pose, new technologies must be utilized as well as the resources that help to aid in our decision making process, thus increasing the vessels combat potential.

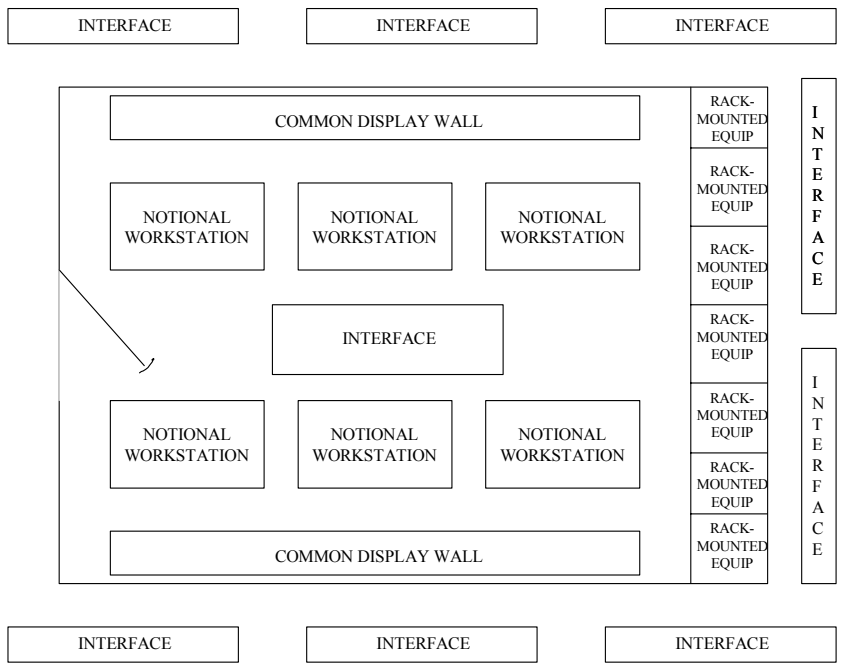

Figure 9. Integrated Operational Combat Environment

Figure 9 is a notional cell displaying a possible architecture that will allow for increased command and control interaction in the battlespace. The external interfaces will include all of the information feeds the ship receives from national, theater, and tactical ISR⁹ assets. These interfaces will be used to determine and formulate an optimal operational picture of the battlespace environment. This picture, in the form of multiple displays with pertinent information to all workstation operators, will be displayed inside the cell on the common display walls. The information will be continually updated based on changes disseminated from the ISR assets as well as changes implemented by all workstations. At each notional workstation, the operator will be in charge of

⁹ Information Surveillance and Reconnaissance Assets.

analyzing their specific element of the battlespace and focusing their attention on that task, while keeping the overall picture in mind. At their disposal, they will have rack-mounted equipment to analyze their information and decipher the intelligence. The operator will have all the tools necessary to complete their task in an orderly fashion. All of the notional workstations will be interconnected via the internal interface. This internal interface will reduce redundancy of tasks and allow for the timely and proper execution of the command and control process.

D. SUMMARY OF EFFECTS IN C2

The introduction of fuel cells, integrated power systems, and directed energy weapons, will result in a more effective combat vessel. This vessel will be less venerable and susceptible to enemy attacks, resulting in a higher combat potential for the vessel commander. The ability of the commander to harness this power and direct it towards the enemy will prove the validity of the technologies.

With the gradual evolution of advancing technologies as discussed in the previous chapter, the likelihood of their use onboard future naval vessels will only increase. This will enable the destroyer fleet to maintain its war-fighting capability for years to come. In turn, the surface fleet will be better prepared to face the future threats with the implementation of these new integrated technologies onboard ships.

IV. RECOMMENDATIONS

A. OVERVIEW

As the world changes, so do the threats facing our nation. Our national defense seeks to implement changes in technology now, in order to combat the future threats on the horizon. This thesis focused on three new and emerging technologies that might prove to be useful in countering such threats. By implementing fuel cells, an integrated power system, and directed energy weapons, a more capable and more powerful fleet can be developed. The primary goal of this thesis was to look at how these technologies might be implemented to better serve the future destroyer fleet.

B. CRITICAL TECHNOLOGIES

Several critical issues were raised throughout this thesis, and valuable lessons were learned. As with everyone's research, the hope is that future decision makers, designers, and systems engineers will consider these findings before implementing new technologies. The investigation of how these technologies might be harnessed for naval use provided the following results.

1. Fuel Cells

The introduction of fuel cells as a power source to naval vessels will offer significant advantages over the current systems in use today. As a powerplant, they will be modular, allowing the required number of generators to be placed on the ship to meet power requirements. Since they are modular, they have significantly fewer moving parts, making them quieter and requiring less maintenance. They offer a clean source of power combining hydrogen and oxygen, with the only outputs being water, electricity, and

heat. They have significantly lower heat signatures than gas turbine or diesel engines, meaning they are less susceptible to attacks by IR seeking devices.

One drawback is the requirement of hydrogen gas as a fuel source. Since hydrogen gas is too flammable to be stored on naval vessels and there is no likelihood of it being transferred between vessels. Existing marine fuels will have to be cleaner allowing better reforming by the fuel cells, allowing ships to produce it internally. Since fuel consumption will be similar to the current fleet, the supply chains will have to remain operational until better methods of production can be developed.

Looking to the future, fuel cells will provide all the ships power requirements. With the implementation of DEW suites, even more power will be required over the current systems. The assumption must be made that the total power requirements will be about 10MW. The molten carbonate fuel cells currently have very capable 2MW plants, which when coupled together, could provide the needed power. This seems the best implementation option looking at the current state of fuel cells. In order to be properly implemented onboard naval vessels, the technology will have to further developed into a more compact and powerful system.

2. Integrated Power System

The combination of fuel cells and IPS will create a much more reliable ship power grid. The IPS provides "continuous power to mission and life critical systems, including during major combat battle damage disruptions." [Ref. 45] By limiting the failure rate of the power distribution system, more time can be spent on the success of the mission rather than focusing on each system fault.

With the addition of IPS, future naval vessels will be electric ships. The bulky mechanical propulsion systems will be replaced by electric motors that will turn the propellers. The fuel cells will produce electrical power and it will be up to the IPS to manage its distribution to propulsion, weapon, and ship systems.

3. Directed Energy Weapons

The use of laser and microwave technologies to replace existing weapon systems could have significant effects for the defense of shipboard platforms. The shift to DEW will offer the ability to intercept and engage threats earlier, leading to a more dynamic, steadfast, and survivable fleet. Their introduction will not make the decision maker better or faster at making decision, rather the technology will allow those decisions to be carried out faster. These systems will not lead to an invincible fleet, but one that allows the commander to more easily deal with the threats encountered in hostile littoral regions.

C. RECOMMENDATIONS

Upon the completion of this thesis, the argument has been presented in favor for the implementation of new technologies such as fuel cells, integrated power systems, and directed energy weapons. These technologies will be implemented first on the near-term, and eventually onto the far-term destroyer platform. The ultimate goal is for the US Navy to remain at the forefront of technological advances and to support our continued dominance in the world theater.

The shipboard command and control process will not be drastically affected with the implementation of DEW for

shipboard defense. The human will remain in the loop as the decision maker. With the use of DEW, the decision makers reaction time will be the same to designate the threat as hostile and generate firing solution as with past weapon systems. The key factor is that the firing of DEW will be as fast as the speed of light. As soon as the order is given to fire, the button pushed, the target will be instantaneous neutralized given that it receives a direct hit. This will allow for real time battle damage assessment, and will allow the commander to broaden his command and control influence over the ever-changing environmental battlespace.

Systems engineers try to keep the balance between organization and complication throughout their work. In the opinion of the authors, the best way to approach the construction of the new variants of the destroyer will be in a concurrent bi-wave integration process. This can be described best as building the modular components and installing them on a seaworthy platform for initial sea trials. Upon the completion of a successful sea trial, the systems engineers can move onto the hull design. By taking the final list of requirements from sea trials and building the new hull design to meet the design requirements, a new age hull can be introduced to the design. An important factor to consider is that the hull and the technology itself are completely independent challenges. We would prefer to take this two-prong approach, as opposed to simultaneous development of both. When this is accomplished, a very versatile and powerful vessel will be ready to defend against the threats of the 21st century.

LIST OF REFERENCES

- 1 Barnett, Thomas. *Esquire*. The Pentagon's New Map. March 2003, Vol. 139, No. 3. pp. 174-175, 227-228.
- 2 Infield, Tom. San Jose Mercury News. Bush's Budget Proposal. Tuesday, February 4, 2003. p. 6A.
- 3 Ibid.
- 4 Ibid.
- 5 Smithsonian Institute. "Fuel Cell Origins." [<http://fuelcells.si.edu/origins.origins.htm>]. April 2003.
- 6 Smithsonian Institute. "Fuel Cell Origins." [<http://fuelcells.si.edu/origins.origins.htm>]. April 2003.
- 7 Hywell Technologies, Inc. "Fuel Cell Basics." [<http://www.fuelcellonline.com/basics.htm>]. April 2003.
- 8 Howstuffworks, Inc. "How Fuel Cells Work." [<http://science.howstuffworks.com/fuel-cell2.htm>]. April 2003.
- 9 Comar, J., *Comparative Design Analysis of a Fuel Cell Powered Coast Guard Cutter*. p. 1. Master's Thesis. Naval Postgraduate School. Monterey, California. June 1996.
- 10 Howstuffworks, Inc. "Efficiency of Fuel Cells." [<http://science.howstuffworks.com/fuel-cell4.htm>]. April 2003.
- 11 Comar, J., *Comparative Design Analysis of a Fuel Cell Powered Coast Guard Cutter*. p. 11. Master's Thesis. Naval Postgraduate School. Monterey, California. June 1996.
- 12 Hywell Technologies, Inc. "Fuel Cell Basics." [<http://www.fuelcellonline.com/basics.htm>]. April 2003.

- 13 Comar, J., *Comparative design analysis of a fuel cell powered Coast Guard cutter*. p. 46. Master's Thesis. Naval Postgraduate School. Monterey, California. June 1996.
- 14 Hywell Technologies, Inc. "Fuel Cell Basics." [<http://www.fuelcellonline.com/basics.htm>]. April 2003.
- 15 Comar, J. *Comparative design analysis of a fuel cell powered Coast Guard cutter*. p. 11. Master's Thesis. Naval Postgraduate School. Monterey, California. June 1996.
- 16 Comar, J., *Comparative design analysis of a fuel cell powered Coast Guard cutter*. p. 46. Master's Thesis. Naval Postgraduate School. Monterey, California. June 1996.
- 17 Comar, J., *Comparative design analysis of a fuel cell powered Coast Guard cutter*. p. 11. Master's Thesis. Naval Postgraduate School. Monterey, California. June 1996.
- 18 Comar, J., *Comparative design analysis of a fuel cell powered Coast Guard cutter*. p. 46. Master's Thesis. Naval Postgraduate School. Monterey, California. June 1996.
- 19 Stoddart, T., *A president with many promises to keep*. U.S. News & World Report, Feb 10, 2003. p. 18.
- 20 Toyota Motors Corp. "How Fuel-Cell Hybrid Vehicles Work." [<http://129.33.47.206/about/environment/technology/fuelcell2.html>]. April 2003.
- 21 Nikkei Business Publications, Inc. "Prototype Fuel Cells to Power Notebook Computers Set for Release in 2004." [<http://neasia.nikkeibp.com/wcs/leaf?CID=onair/asabt/fw/241915>]. April 2003.
- 22 Defense Technology Information Center, Military Critical Technology List. "Developing Critical Technology, Section 13.2 Marine Systems Technology - Propulsion." [<http://www.dtic.mil/mctl/>]. March 2003.

- 23 Cerrito, J., *Neural Network Control of the Integrated Power System*. Trident Scholar Project, Number 273. United States Naval Academy. Annapolis. Maryland. May 2000.
- 24 Ibid.
- 25 Chiafair, D., *Stability Analysis of a Nonlinear System Stabilizing Controller for an Integrated Power System*. U.S.N.A Trident Scholar Project, Number 289. United States Naval Academy. Annapolis. Maryland. May 2002.
- 26 Ibid.
- 27 Ibid.
- 28 Ibid.
- 29 Vanecko, J., *Advanced Shipboard Control Systems*. U.S.N.A. Trident Scholar Project, Number 286. United States Naval Academy. Annapolis. Maryland. May 2001.
- 30 McCoy, T. and Zivi, E., "Control of a Shipboard Integrated Power System," paper presented at the Conference on Information Sciences and Systems. John Hopkins University. Baltimore. Maryland. 25 May 1999.
- 31 Lively, K. and others., "Advanced Control Concepts for an Integrated Power System (IPS) Warship," paper presented at the *International Naval Engineering Conference and Exhibition*, 5th. 15 March 2000.
- 32 Martel, W. *The technological arsenal: emerging defense capabilities*. p. 62. Smithsonian Institute Press. 2001.
- 33 Schroeer, D. *Directed-energy weapons and strategic defence: a primer*. p. 13. International Institute for Strategic Studies. 1987.
- 34 Ibid
- 35 Schroeer, D. *Directed-energy weapons and strategic defence: a primer*. p. 16. International Institute for Strategic Studies. 1987.
- 36 Schleher, D. *Electronic Warfare in the Information Age*. p. 462. Artech House. 1999.

- 37 Martel, W. *The technological arsenal: emerging defense capabilities*. p. 64. Smithsonian Institute Press. 2001.
- 38 Schleher, D. *Electronic Warfare in the Information Age*. p. 475. Artech House. 1999.
- 39 Schleher, D. *Electronic Warfare in the Information Age*. p. 478. Artech House. 1999.
- 40 Williams, R. "Fleet survey provides input for 'sit-up berth'," *All Hands...Online*, Website: <http://www.chinfo.navy.mil/navpalib/allhands/ah0497/apr-pg08.html> Visited: 19 May 2003.
- 41 USS Benfold (DDG-65) *Engineering Handbook*. p. 62.
- 42 Martel, W. *The technological arsenal: emerging defense capabilities*. p. 55. Smithsonian Institute Press. 2001.
- 43 Ibid
- 44 Mack, W., McComas, L., and Seymour, H. *The Naval Officer's Guide, 11th Edition*. p. 160. Naval Institute Press. 1998.
- 45 Chiafir, D. *Stability Analysis of Nonlinear System Stabilizing Controller for an Integrated Power System*. p. 1.

INITIAL DISTRIBUTION LIST

1. Defense Technical Information Center
Ft. Belvoir, Virginia
2. Dudley Knox Library
Naval Postgraduate School
Monterey, California
3. Orin Marvel
Naval Post Graduate School
Monterey, California
4. D.C. Boger
Naval Post Graduate School
Monterey, California
5. CAPT Jeffrey Kline, USN
Chairman, Warfare Innovation
Naval Postgraduate School
Monterey, California