

REPORT DOCUMENTATION PAGE

AFRL-SR-AR-TR-03-

Public reporting burden for this collection of information is estimated to average 1 hour per response, including the time for reviewing instructions, searching the collection of information. Send comments regarding this burden estimate or any other aspect of this collection of information, including suggestions: Operations and Reports, 1215 Jefferson Davis Highway, Suite 1204, Arlington, VA 22202-4302, and to the Office of Management and Budget, Paperwork

0345

1. AGENCY USE ONLY (Leave blank)

2. REPORT DATE

3. REPORT TYPE AND DATES COVERED

15 Nov 2000 - 31 Dec 2002 Final Report

4. TITLE AND SUBTITLE

Non-Destructive of defects in Wires and other samples using an 8-Channel High TC-Scanning Microscope

5. FUNDING NUMBERS

61102F
2305/GX

6. AUTHOR(S)

Professor Wellstood

7. PERFORMING ORGANIZATION NAME(S) AND ADDRESS(ES)

UNIVERSITY OF MARYLAND
OFFICE OF RESEARCH ADMINISTRATION
AND ADVANCEMENT
COLLEGE PARK MD 20742-5141

8. PERFORMING ORGANIZATION
REPORT NUMBER

9. SPONSORING/MONITORING AGENCY NAME(S) AND ADDRESS(ES)

AFOSR/NE
4015 WILSON BLVD
SUITE 713
ARLINGTON VA 22203

10. SPONSORING/MONITORING
AGENCY REPORT NUMBER

F49620-01-1-0062

11. SUPPLEMENTARY NOTES

12a. DISTRIBUTION AVAILABILITY STATEMENT

APPROVED FOR PUBLIC RELEASE, DISTRIBUTION UNLIMITED

12b. DISTRIBUTION CODE

13. ABSTRACT (Maximum 200 words)

The last task for the system was to reinstall a chip with up to 8 working SQUIDS. In fact, the chip we have used for the last year and a half started with seven working devices, but damage has accumulated (broken wire bonds, junction failure and damage incurred when the thin window broke) and only two devices are presently working on the chip. Su Lee has a back-up chip for use, with about 6 operating SQUIDS on it, and we expect to swap out the existing chip in the next few months (when we are done running 2-SQUID imaging tests) or sooner if it chip faily completely.

14. SUBJECT TERMS

15. NUMBER OF PAGES

16. PRICE CODE

17. SECURITY CLASSIFICATION
OF REPORT

UNCLASSIFIED

18. SECURITY CLASSIFICATION
OF THIS PAGE

UNCLASSIFIED

19. SECURITY CLASSIFICATION
OF ABSTRACT

UNCLASSIFIED

20. LIMITATION OF ABSTRACT

UL

Final Report
on
"Non-Destructive Evaluation of Defects in Wires
and Other Samples
Using an 8-Channel High-T_c Scanning SQUID Microscope"

AFOSR Grant F496200110062
UMD Project number 528353
August 26, 2003

PI: Fred Wellstood

Associate Professor

Department of Physics

University of Maryland

College Park, MD 20742-4111

301-405-7649

well@squid.umd.edu

20030915 009

Outline

1. Project Summary
2. High-T_c SQUID chip
3. Assembly of the Microscope
4. Results on Wire NDE
5. Personnel

1. Project Summary

The project "Non-Destructive Evaluation of Defects in Wires and Other Samples using an 8-Channel High-T_c Scanning SQUID Microscope" involves the development, construction, and operation of a sensitive magnetic microscope which is based on the dc Superconducting QUantum Interference Device (SQUID). During this project we constructed a system by modifying one of an existing 1-channel liquid-nitrogen cooled SQUID microscope to hold an array of 8 high-T_c YBCO SQUIDs. The SQUID chip was mounted on the end of a 77 K cold-finger in the vacuum space of a dewar that has a thin (25 μm) window that separates the vacuum from room-temperature air. The system will mainly be used to image yields, voids, and occlusions in Cu-clad NbTi superconducting magnet wires and in high-T_c superconducting wire samples, with the aim being to provide reliable detection of defects that cause reduced critical current.

2. High-T_c SQUID chip

Figure 1 shows the design of our eight high-T_c sensor SQUIDs. All eight SQUIDs are made at the same time on one chip. When mounted in the scanning microscope, the chip are aligned so that the normal to the surface of the chip, and thus the normal to the SQUID loops, will be parallel to the main scanning direction (which we will call the x-direction).

Each SQUID has a rectangular loop with an inside area of $30\ \mu\text{m}$ by $60\ \mu\text{m}$, with the narrow side being oriented horizontally in the final apparatus and the long side vertically. The SQUIDs are spaced by about $200\ \mu\text{m}$, and arranged in the form of a bar scanner with a total length of $1.6\ \text{mm}$. Each SQUID has its own flux modulation and feedback line, which is simply a YBCO thin-film wire which passes within about $5\ \mu\text{m}$ of the SQUID.

After patterning, a diamond saw was used to dice the chip into three chips each containing 8 SQUIDs. The three chips are arranged so that the angled cuts needed for the lower section of each chip can be completed at this stage. The end of the chip is then carefully polished to bring the SQUIDs as close as possible to the end of the chip without damaging them. Figure 2 shows a completed chip.

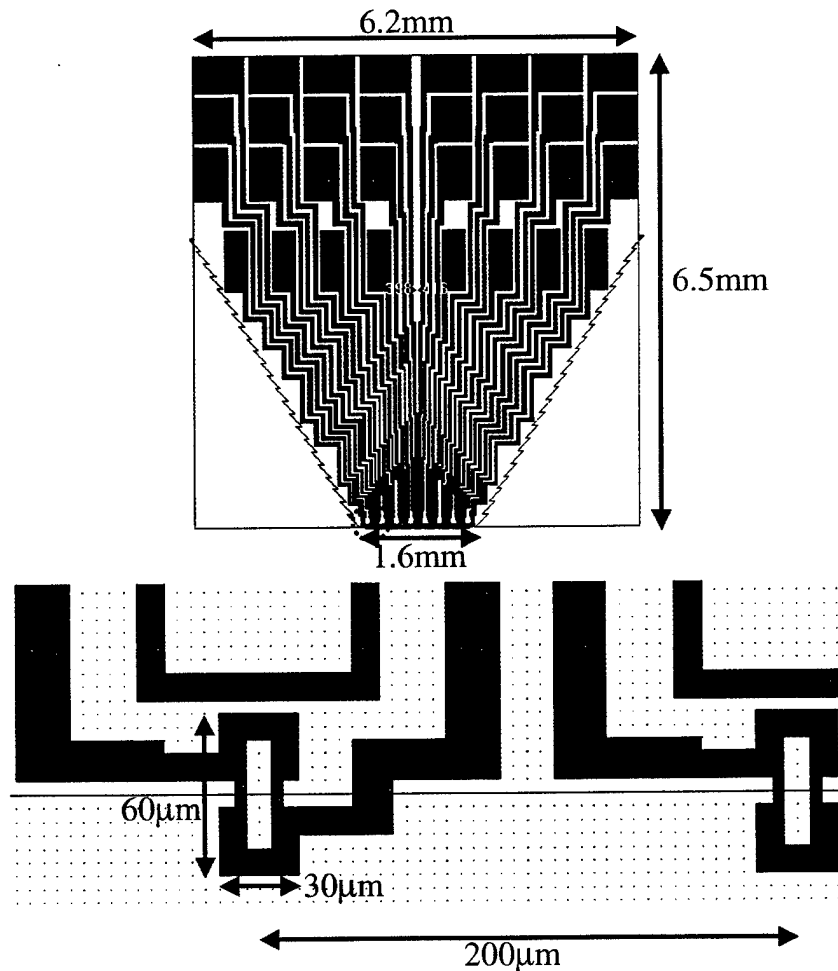

Fig. 1. Design of the 8-SQUID chip (upper diagram) and individual SQUID on the Chip (lower diagram).

We were not able to get a chip with all 8 SQUIDs working. On our best chip, we found that 7 of the 8 chips showed a reasonable response, with the last SQUID showing no conductance, probably do to failed junctions. Table 1 summarizes the parameters for the SQUIDs on this chip. Although the parameters of the working devices varied by about a factor of two, the range was acceptable in so far as the SQUID performance was concerned. During subsequent handling and installation and use of the chip, three additional devices were damaged leaving a chip with 4 working SQUIDs. We judged this to be adequate for initial testing of the microscope and have been using this chip for about the last year.

3. Assembly of the Microscope

The new system was built by upgrading our existing 1-SQUID liquid-nitrogen cooled system. Completing this upgrade required making several major changes, including: installing an



Fig. 2. Photo of completed 8-SQUID sensor chip with wire bond connections. Contact pads on the PC board are visible at the top of the photo.

Table 1. Measured parameters of 6 operating SQUIDs on a single 8-SQUID chip.

	CH1	CH2	CH3	CH4	CH6	CH8
$I_c = 2I_o$ (μA)	38	65	28	40	32	60
ΔV (μV)	50	55	45	50	50	60
RJ (Ω)	4.9	4.3	5.0	4.8	4.5	4.8
$\beta = 2I_o L / \Phi_o$	0.76	1.3	0.56	0.8	0.64	1.2

8-SQUID chip and readout electronics, rewiring the cryostat to handle 8-SQUIDs, rewriting the data acquisition software, and rebuilding the nose cone and thin window to accept a larger chip size.

During the last year, we installed an 8-channel set of PC SQUID electronics from Star Cryoelectronics. To use the electronics with our SQUIDs, we had to modify the circuitry so that they could deliver more bias current, ac modulation and dc flux bias. This was done after consultation with the company's president, R. Cantor. The performance appears to be adequate for our purposes, and in particular, we have been able to run with several SQUIDs locked at the same time.

Figure 3 shows a schematic of modifications that we have made in the lower section of the liquid-nitrogen cooled SQUID microscope. The main difficulty has been in putting in the many wires (about 48 total) needed for the SQUIDs. In addition, we had to install a new completed nose cone with a trench style window for the 8-SQUID system.

There were a few problems that arose during assembly. First, it was difficult to install the new wiring assembly and cold finger in the system. The system must be bolted to the inside bottom of the liquid nitrogen dewar, and there is just barely enough space to tighten the bolts

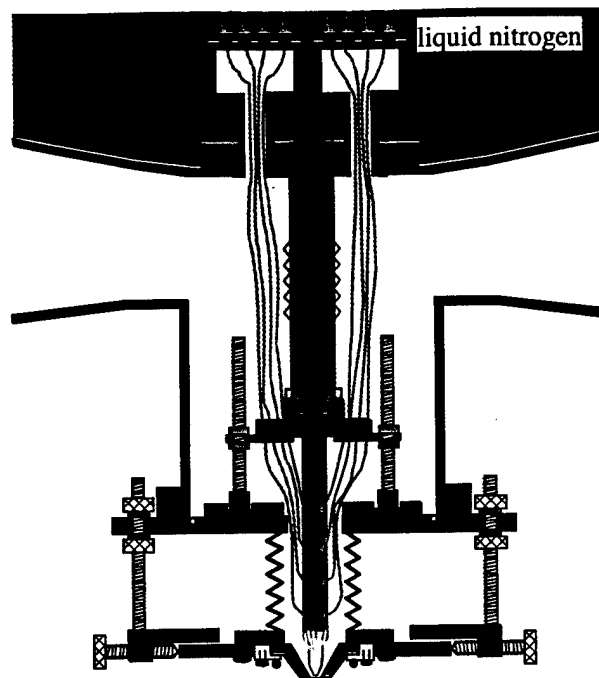

Fig. 3. Colored parts show modifications that we completed in the lower section of the liquid nitrogen cooled microscope.

holding a cold indium seal. Second, we had a persistent cryogenic leak in the wiring chamber. We eventually traced this down to one of the bolt holes for the cold indium seal. The machinist had drilled a through hole instead of a blind hold. We corrected this by welding the hole shut and putting in a new blind hole, and the system there after was vacuum tight. Tracking down this problem was frustrating because of the difficulty of installing and removing the cold finger, as mentioned above. Finally, the out-gassing rate of the system was higher than expected. To correct this, we attached a bag of charcoal to a cold point in the vacuum space, and this cured the problem.

4. Results on Wire NDE

Figures 4 and 5 show two examples of images taken with the multi-SQUID system. The first is of a simple fine straight wire, and the second is of a wire that is bent out of the x-y plane.

In both cases, the output was taken from a single channel. Comparison of the output from different channels shows the expected differences due to the small offset in SQUID positions.

As discussed in my last report, before we disassembled the 1-SQUID microscope, we used it to investigate a new technique for finding yields in NbTi wires. The idea was to apply current to the wires at two different frequencies and then compare the resulting magnetic image of the wires with the SQUID oriented in the x-direction. The first frequency was chosen to be low enough, a hundred Hz to a kHz, so that the skin depth was large compared to the wire diameter, ensuring uniform current flow through the wire cross-section. The second frequency was chosen high enough, 15 kHz or higher, that the penetration depth was smaller than the wire diameter, ensuring that the current flow was predominately on the outer portion of the wire cross-section. Since the magnetic images show the current flow in the wire, any difference between the images would be due to the high frequency and low frequency currents taking different paths as they avoided a flaw.

The advantage of this approach is that it can distinguish buried flaws in the wire from simple bends in the wire. If the wire is bent, one expects that both low and high frequencies will tend to follow the wire bend and the magnetic images will be very similar. Anders Gilbertson was able to show that subtraction of two images of a bent wire taken at two different frequencies showed no discernible signal while subtraction showed a clear signal when a buried yield was present.

4. Final work

In the last six months of the project (September 2002 to the extended ending date of March 2003), there were three main tasks that needed to be completed to finish off the project.

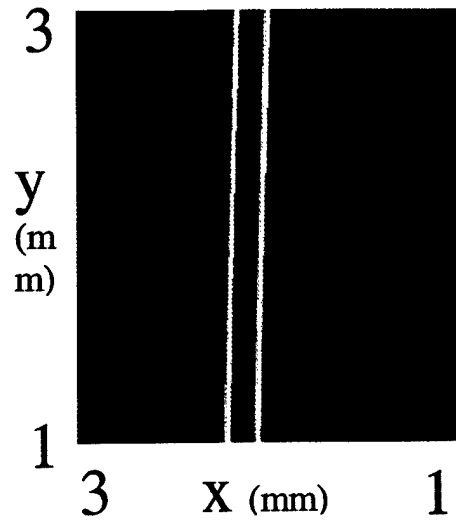

Fig. 3. image of x-component of magnetic field from a fine wire measured by new multi-SQUID microscope.

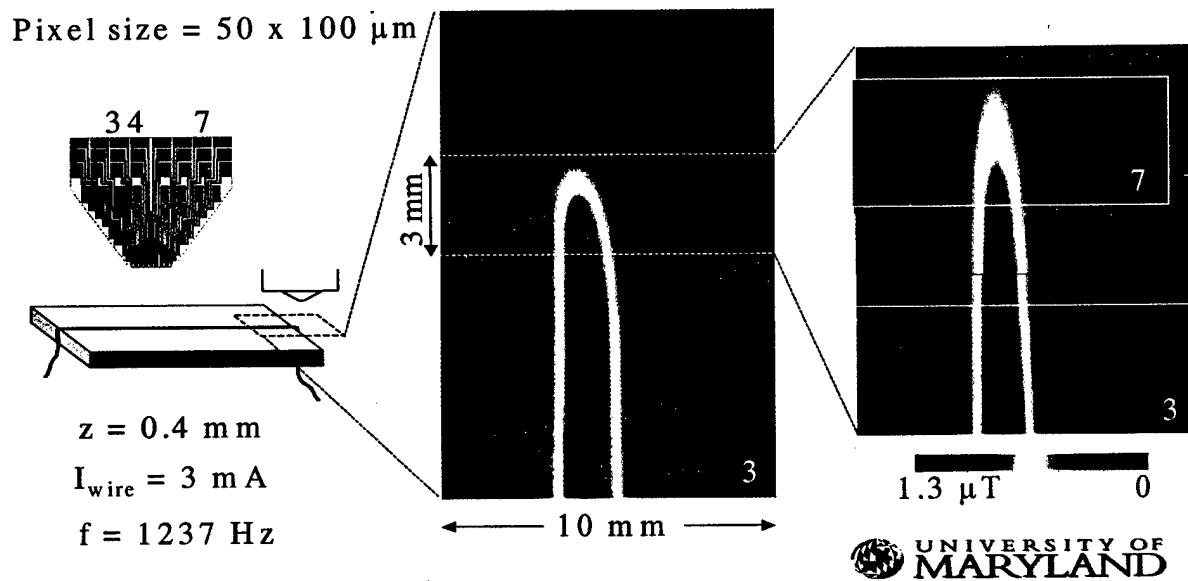

Fig. 4. Image of x-component of magnetic field from the end of a fine wire measured by three SQUIDs on the multi-SQUID microscope.

The first task was to complete the software for reading out and controlling multiple SQUIDS. We had recently purchased a Newport 0.1 μm precision x-y translation stage and needed to upgrade the software and data acquisition board to allow simultaneous read out. This required completely rewriting the controlling software. This task was completed, and we have now been able to take simultaneous data for two SQUIDS with very good precision position resolution (down to 0.1 μm).

The second task was to compare the system performance to a flow-through SQUID system which was under development for testing long sections of wires. This part of the project was delayed beyond the ending date because there was a delay in getting a working SQUID installed in the flow-through system. As a result, the comparison will be accomplished in a succeeding project on the flow-through system. However, some conclusions can already be drawn from preliminary results on our prototype flow-through system. In particular, we have been able to pull wires at speeds of up to about 1.3 m/s while injecting current in the wire and maintaining a lock on the SQUID. In addition, we have been able to inject two currents at different frequencies and show that the high-frequency low-frequency subtraction technique removes artifacts arising from bending and the motion of the wire in the system. These characteristics suggest that the flow-through system may have significant advantages in speed over the scanning SQUID microscope, as expected. Needless to say, much work needs to be done though, in particular, we need to determine how sensitive the flow-through system is to defects when it is run at speed.

The last task for the system was to reinstall a chip with up to 8 working SQUIDS. In fact, the chip we have used for the last year and a half started with seven working devices, but damage has accumulated (broken wire bonds, junction failure and damage incurred when the thin

window broke) and only two devices are presently working on the chip. Su Lee has a back-up chip for use, with about 6 operating SQUIDs on it, and we expect to swap out the existing chip in the next few months (when we are done running 2-SQUID imaging tests) or sooner if it chip fail completely.

5. Personnel

During this project, the main personnel were Su-Young Lee (a Physics Graduate Student Research Assistant), Anders Glibertson (an Undergraduate Physics Student), Dr. John Matthews (post-doc), and Greg Moore (an Undergraduate Engineering Student). Su was responsible for designing, fabricating and assembling the new system and is expected to complete her Ph.D. in December 2003. Both Anders and Su were responsible for imaging. Anders graduated in May 2002 with a Physics B.S. and has begun work at Neocera. Dr. John Matthews began in February, 2002 after completing his Ph.D. with Dr. Marvin Cage at NIST and now oversees all our SQUID projects. Greg Moore worked on a part-time basis to help with reprogramming the control software to handle the 8-SQUID setup.