

NAVAL POSTGRADUATE SCHOOL
Monterey, California



THESIS

**AUTOPILOT USING DIFFERENTIAL THRUST FOR
ARIES AUTONOMOUS UNDERWATER VEHICLE**

by

Christopher J. Sarton

June 2003

Thesis Advisor:

Anthony J. Healey

Approved for public release; distribution is unlimited

THIS PAGE INTENTIONALLY LEFT BLANK

REPORT DOCUMENTATION PAGE			<i>Form Approved OMB No. 0704-0188</i>
Public reporting burden for this collection of information is estimated to average 1 hour per response, including the time for reviewing instruction, searching existing data sources, gathering and maintaining the data needed, and completing and reviewing the collection of information. Send comments regarding this burden estimate or any other aspect of this collection of information, including suggestions for reducing this burden, to Washington headquarters Services, Directorate for Information Operations and Reports, 1215 Jefferson Davis Highway, Suite 1204, Arlington, VA 22202-4302, and to the Office of Management and Budget, Paperwork Reduction Project (0704-0188) Washington DC 20503.			
1. AGENCY USE ONLY (Leave blank)	2. REPORT DATE June 2003	3. REPORT TYPE AND DATES COVERED Master's Thesis	
4. TITLE AND SUBTITLE: Autopilot Using Differential Thrust For ARIES Autonomous Underwater Vehicle			5. FUNDING NUMBERS
6. AUTHOR(S) Christopher J. Sarton			8. PERFORMING ORGANIZATION REPORT NUMBER
7. PERFORMING ORGANIZATION NAME(S) AND ADDRESS(ES) Naval Postgraduate School Monterey, CA 93943-5000			10. SPONSORING/MONITORING AGENCY REPORT NUMBER
9. SPONSORING /MONITORING AGENCY NAME(S) AND ADDRESS(ES) N/A			11. SUPPLEMENTARY NOTES The views expressed in this thesis are those of the author and do not reflect the official policy or position of the Department of Defense or the U.S. Government.
12a. DISTRIBUTION / AVAILABILITY STATEMENT Approved for Public Release; Distribution is Unlimited			12b. DISTRIBUTION CODE
13. ABSTRACT (maximum 200 words) Future underwater missions will require data transmission via satellite. In particular, the Office of Naval Research (ONR) is interested in experimenting with communications using the GOES satellite system, which is government owned. Unfortunately, communication antennas must point to specific satellites in this system and thus underwater vehicles must steer a specific course on the surface during the communication process. While surfaced, underwater vehicles are subject to wind and wave disturbances and it has been suggested that control using differential thrust from propellers may provide advantages. This thesis covers efforts to create and test such a steering autopilot based on the use of the ARIES AUV and differing the voltage supplied to each propeller. It is planned to use the ARIES in an ocean experiment to test this satellite communication capability. This control is embedded in the control of ARIES during extended pop up maneuvers for GPS navigational fixes. When surfaced, not only are navigational fixes obtained, but also data packets are communicated to a command center.			
14. SUBJECT TERMS differential thrust, AUV, Autonomous Underwater Vehicle, autopilot			15. NUMBER OF PAGES 61
			16. PRICE CODE
17. SECURITY CLASSIFICATION OF REPORT Unclassified	18. SECURITY CLASSIFICATION OF THIS PAGE Unclassified	19. SECURITY CLASSIFICATION OF ABSTRACT Unclassified	20. LIMITATION OF ABSTRACT UL

THIS PAGE INTENTIONALLY LEFT BLANK

Approved for public release; distribution is unlimited

**AUTOPILOT USING DIFFERENTIAL THRUST FOR ARIES AUTONOMOUS
UNDERWATER VEHICLE**

Christopher J. Sarton
Lieutenant, United States Navy
BS, Massachusetts Institute of Technology, 1996

Submitted in partial fulfillment of the
requirements for the degree of

MASTER OF SCIENCE IN MECHANICAL ENGINEERING

from the

**NAVAL POSTGRADUATE SCHOOL
June 2003**

Author: Christopher J. Sarton

Approved by: Anthony J. Healey
Thesis Advisor

Young Kwon
Chairman, Department of Mechanical Engineering

THIS PAGE INTENTIONALLY LEFT BLANK

ABSTRACT

Future underwater missions will require data transmission via satellite. In particular, the Office of Naval Research (ONR) is interested in experimenting with communications using the GOES satellite system, which is government owned. Unfortunately, communication antennas must point to specific satellites in this system and thus underwater vehicles must steer a specific course on the surface during the communication process. While surfaced, underwater vehicles are subject to wind and wave disturbances and it has been suggested that control using differential thrust from propellers may provide advantages. This thesis covers efforts to create and test such a steering autopilot based on the use of the ARIES AUV and differing the voltage supplied to each propeller. It is planned to use the ARIES in an ocean experiment to test this satellite communication capability. This control is embedded in the control of ARIES during extended pop up maneuvers for GPS navigational fixes. When surfaced, not only are navigational fixes obtained, but also data packets are communicated to a command center.

THIS PAGE INTENTIONALLY LEFT BLANK

TABLE OF CONTENTS

I.	INTRODUCTION.....	1
A.	BACKGROUND	1
B.	PROBLEM STATEMENT	2
II.	CONTROL METHODS.....	3
A.	THE BASICS.....	3
B.	SYSTEM OF EQUATIONS.....	3
1.	Three State Model.....	4
C.	SLIDING MODE CONTROL	5
D.	PROPORTIONAL CONTROL.....	6
III.	EXPERIMENTAL TESTING AND RESULTS	9
A.	PROCEDURE	9
B.	RESULTS	10
1.	31 March 2003	10
2.	9 April 2003	13
a.	<i>Second Run</i>	14
b.	<i>Fourth Run</i>	15
3.	30 April 2003	17
a.	<i>First Run</i>	18
b.	<i>Second Run</i>	18
c.	<i>Third Run</i>	21
4.	9 May 2003.....	25
5.	23 May 2003.....	29
C.	TABLES OF RESULTS.....	34
IV.	CONCLUSIONS	37
A.	CONTROL MODE CONCLUSIONS.....	37
B.	RECOMMENDATIONS FOR FURTHER WORK.....	37
	APPENDIX.....	39
	‘ENGINE5.M’	39
	‘EXECF.C’	41
	LIST OF REFERENCES.....	43
	INITIAL DISTRIBUTION LIST	45

THIS PAGE INTENTIONALLY LEFT BLANK

LIST OF FIGURES

Figure 1 SIMULINK diagram of sliding mode system	6
Figure 2 SIMULINK diagram of proportional control	7
Figure 3 31 March: heading of entire run #1	10
Figure 4 31 March: North run #1; showing number of satellites in blue and heading in green.....	11
Figure 5 31 March: South run#1; satellites (blue) and heading (green)	12
Figure 6 31 March: run#1; thrust effort between port and starboard screws.....	12
Figure 7 9 April: Run #1; red port thrust (Volts), green starboard, blue number of satellites.....	13
Figure 8 9 April: run #1 heading.....	14
Figure 9 9 April: run #2; red port.....	15
Figure 10 9 April: run #2 heading.....	16
Figure 11 9 April: run #4; red port.....	16
Figure 12 9 April: run #4 heading.....	17
Figure 13 30 April #1 turn rate and thruster voltage	18
Figure 14 30 April: run #2	19
Figure 15 30 April: run #2; the heading is in green while the number of satellites in blue.....	20
Figure 16 close up view north portion of second run	20
Figure 17 30 April: run #2	21
Figure 18 30 April: run #3	22
Figure 19 30 April: run #3	22
Figure 20 East portion of run #3	23
Figure 21 South portion of run #3.....	24
Figure 22 30 April: run #3	25
Figure 23 9 May: heading for entire run and number of satellites.....	26
Figure 24 9 May; western track heading.....	27
Figure 25 9 May: turn rate and thruster voltage	28
Figure 26 23 May: turn rate and thruster voltage	30
Figure 27 23 May: heading for entire run.....	31
Figure 28 23 May: heading and thruster voltage for east leg; port thruster is red, starboard is green.....	32
Figure 29 23 May: heading and voltage for south leg	32
Figure 30 23 May: heading and voltage for west leg.....	33

THIS PAGE INTENTIONALLY LEFT BLANK

LIST OF TABLES

Table 1 Data results for 9 April 2003	34
Table 2 Data results for 30 April 2003	35
Table 3 Data results for 9 May 2003	35
Table 4 Data results for 23 May 2003	36

THIS PAGE INTENTIONALLY LEFT BLANK

ACKNOWLEDGMENTS

The author would like to thank Prof. Healey for his energy and patience. His guidance throughout the process kept me on track and enthusiastic. Additionally, without the help of CAPT Jack Nicholson, USN; CDR Bill Marr, USN; CDR Doug Horner, USNR; LT Matt Phaneuf, USN and Mr. Greg McCrill none of this would have been possible. Their help in running experiments both from the command trailer and the boat was indispensable.

THIS PAGE INTENTIONALLY LEFT BLANK

I. INTRODUCTION

A. BACKGROUND

Future mission requirements will call for satellite communications while the ARIES Autonomous Underwater Vehicle (AUV) is surfaced. The Office of Naval Research is investigating a satellite system and communications package that would support two-way, worldwide communications. There are two current satellite systems that would be appropriate to these missions, the INTELSAT and the IRIDIUM Systems. Both systems are currently operational and would be able to support ONR requirements.

IRIDIUM uses 77 satellites in Low-Earth-Orbit (LEO) to cover every point on the globe (Grub, 1991). The satellites are inexpensive, lightweight and allow a data transfer rate of 2400 baud (Grub, 1991). The IRIDIUM system would support maritime communications using L-band commercial satellites and is a good choice for AUV satellite links.

The other system, INTELSAT, is part of the Oceanographic Data Link (ODL) that is capable of worldwide communications using C-band satellites. The link is two-way capable, transmits and receives at 900 bits/second, and only requires an antenna the size of a quarter (Gamache, 2001)—ideal for a small, autonomous vehicle. Using these satellites would cut down on cost because they require only three satellites for full coverage (Gamache, 2001). ARIES would be able to transmit data to a receiving station many miles away allowing a greater dissemination of data and operating range. Although IRIDIUM has a faster transfer rate, ONR is interested in the use of the INTELSAT system because it makes use of pre-existing, geosynchronous government-owned satellites.

Since the current incarnation of the ARIES Autonomous Underwater Vehicle has no ventral rudders, it has no control while on the surface save for that provided by its twin thrusters. As of the writing of this thesis, a pointing device for positioning the antenna has not been developed; hence, communicating with the satellite requires the vehicle to be heading in a certain direction in order to point at the proper satellite. The

advantage of the patch antenna is that its broad beam width does not require precise positioning—only that ARIES point in the general direction (Gamache, 2001). The vehicle would have to be able to respond to and compensate for such outside forces as current and wave action through the use of its thrusters alone.

B. PROBLEM STATEMENT

The work in this thesis is aimed at determining whether a differential thrust autopilot—responsive to waves and current—is able to keep ARIES within a bounded course necessary for a communications link to the INTELSAT system or whether a ventral rudder system must be added. To do this, experiments on the heading control of the surfaced ARIES vehicle were conducted using differential thrust between port and starboard propulsion units.

II. CONTROL METHODS

A. THE BASICS

In order to point at a satellite while on the surface with the rudders completely out of the water, differential thrust must be used. A control mode is necessary to regulate the moment generated by the motors and keep the vehicle on track. Track control is the process of keeping a vehicle on a designated track as defined by a pair of geographic waypoints. Heading control is the process of keeping the vehicle's course or heading at a prescribed value. In this work, the required function is heading control. The two methods tried to maintain heading control were sliding mode control and proportional control.

The control mode regulates the feedback of heading error to determine an input of motor moment. The error follows the form

$$error = current_heading - track_heading \quad (2.1)$$

where the error needs to be bounded between $\pm \pi$ radians (180 degrees). This distinction becomes critical as will be seen later. Our goal when designing the autopilot was to keep the error within ± 30 degrees, which will still allow the vehicle to communicate with the given satellite.

The track heading is determined by taking the four quadrant inverse tangent of the line drawn between two consecutive waypoints. This heading is limited between ± 180 degrees so that a westerly track is actually denoted as -90 degrees. Since a heading of 270 degrees (due West) would always result in a positive error whether the vehicle was to the right or left of track, it is of great importance that the error be limited to ± 180 degrees and thus keep the vehicle turning in the proper direction to correct its heading.

B. SYSTEM OF EQUATIONS

The system of equations follows that of a basic six degrees of freedom model for an underwater body. The x and y-axes are defined as North and East, respectively while

the z-axis is down. Since the focus is on surface operation, the z-axis is ignored along with the pitch and roll equations leaving only v (lateral velocity or sway), r (turn rate), and psi (heading); the model is taken from Healey (2003):

1. Three State Model

$$\begin{cases} m\dot{v}_r = -mU_0r + Y_{\dot{v}_r}\dot{v}_r + Y_{v_r}v_r + Y_{\dot{r}}\dot{r} + Y_r r + Y_{\delta}\delta_r(t) \\ I_{zz}\dot{r} = N_{\dot{v}_r}\dot{v}_r + N_{v_r}v_r + N_{\dot{r}}\dot{r} + N_r r + N_{\delta}\delta_r(t) \\ \dot{\psi} = r \end{cases} \quad (2.2)$$

Since the rudders are out of the water, Y_{δ} , N_{δ} , and $\delta_r(t)$ in (2.2) are 0. A new input term, $\delta_e(t)$, is needed to describe the differential moment from the motors. The added mass and force coefficients used in (2.2) were taken from Johnson (2001).

Equation (2.2) in matrix form modified to measure thruster moment and account for wave action looks like the following:

$$\begin{bmatrix} m - Y_{\dot{v}_r} & -Y_{\dot{r}} & 0 \\ -N_{\dot{v}_r} & I_{zz} - N_{\dot{r}} & 0 \\ 0 & 0 & 1 \end{bmatrix} \begin{bmatrix} \dot{v}_r \\ \dot{r} \\ \dot{\psi} \end{bmatrix} = \begin{bmatrix} Y_{v_r} & Y_r - mU_0 & 0 \\ N_{v_r} & N_r & 0 \\ 0 & 1 & 0 \end{bmatrix} \begin{bmatrix} v_r \\ r \\ \psi \end{bmatrix} + \begin{bmatrix} 0 \\ 1 \\ 0 \end{bmatrix} \delta_e(t) + \begin{bmatrix} Y_w \\ N_w \\ 0 \end{bmatrix} x_d(t) \quad (2.3)$$

This matrix follows the basic form

$$\mathbf{M}\dot{\mathbf{x}} = \mathbf{A}\mathbf{x} + \mathbf{B}u + \mathbf{F}d \quad (2.4)$$

- M is the mass matrix
- A is the vehicle dynamics matrix
- B is the input parameters matrix
- u is the motor input
- F is the disturbance matrix
- d is the wave disturbance.

For the purpose of initial study, the waves were modeled as a sine wave with a two second period, and coefficients were estimated to match the experimentally determined course change of twenty degrees.

$$disturbance = \begin{bmatrix} Y_w \\ N_w \end{bmatrix} \sin(\pi t) \quad (2.5)$$

The waves produce two effects on the vehicle: a lateral force (Y_w) and a moment (N_w).

C. SLIDING MODE CONTROL

Sliding mode control follows the form (Healey, 2003)

$$u = -kx - \eta sat \operatorname{sgn}\left(\frac{\sigma}{\phi}\right) \quad (2.6)$$

where u is the moment imparted upon the vehicle with units of Nm. Poles were chosen at 0, -0.2, and -0.4 rad/sec to allow for a slow vehicle response, and the gain, k , was found using the MATLAB 'place' command (refer to the Appendix for the code used). The closed loop form ($A_c = A - Bk$) was found from the A and B matrices from equation (2.3). The eigenvalues of A_c determined s such that $A_c^T s = 0$. Finally, the sliding surface, σ , was found from $s^T \tilde{x}$ where $\tilde{x} = x - x_{command}$ (Healey, 2002). With the calculated values substituted in, Equation (2.6) takes the form:

$$u = 7.8124v - 8.5766r - 10sat \operatorname{sgn}(-0.0842v + 0.8722r + 0.4708\tilde{y}). \quad (2.7)$$

Since the vehicle cannot control v (sway), the equation simplifies to

$$u = -8.5766r - 10sat \operatorname{sgn}(0.8722r + 0.4708\tilde{y}). \quad (2.8)$$

The saturation limit, η , was set to 10 to limit the moment to within what the thrusters could reasonably produce.

Refer to Figure 1 for the SIMULINK drawing of the system using sliding mode control. SIMULINK was used to model the system and test for initial stability before the vehicle was taken out on the water

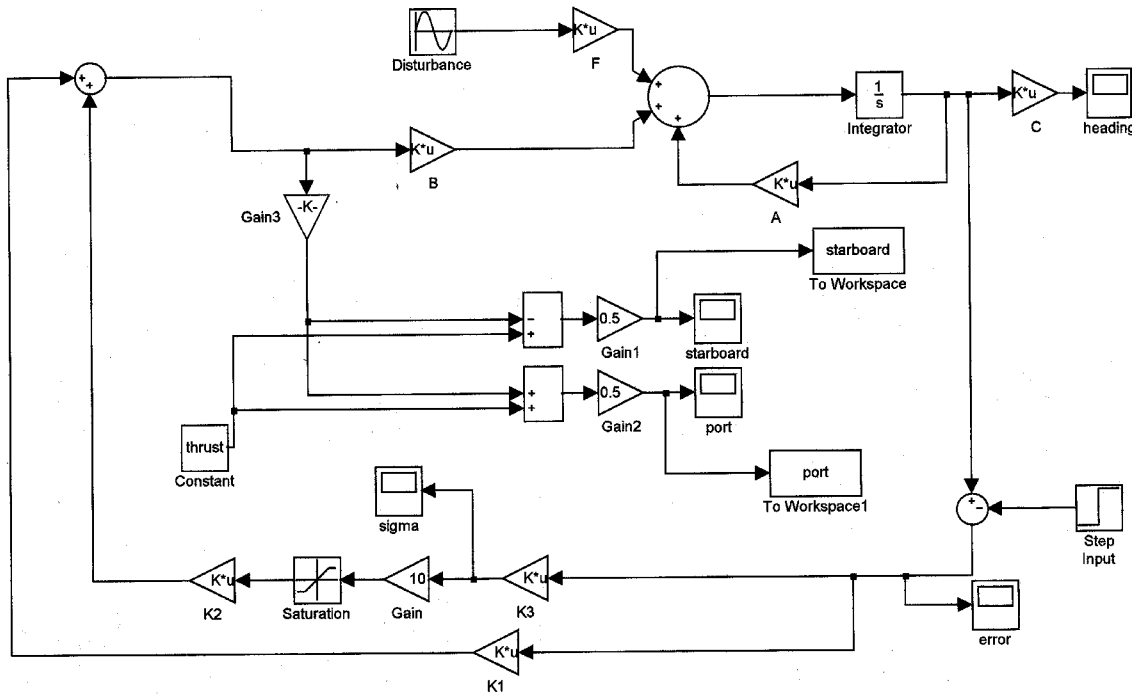

Figure 1 SIMULINK diagram of sliding mode system

D. PROPORTIONAL CONTROL

The second method tried was proportional control. A simple proportional feedback loop was built using a hyperbolic tangent as a switching term to filter out wave noise. The control law was:

$$u = -1.3 * \tanh(30 * \tilde{\psi}) \quad (2.9)$$

The maximum moment is ± 1.3 Nm and occurs approximately 6 degrees off desired heading.

Figure 2 contains the SIMULINK drawing of the proportional system. Wave disturbance, F , is modeled, and each state can easily be monitored by use of the various scopes. Again, SIMULINK was used to approximate the system stability and test to see that the control was operating in the correct direction to correct heading.

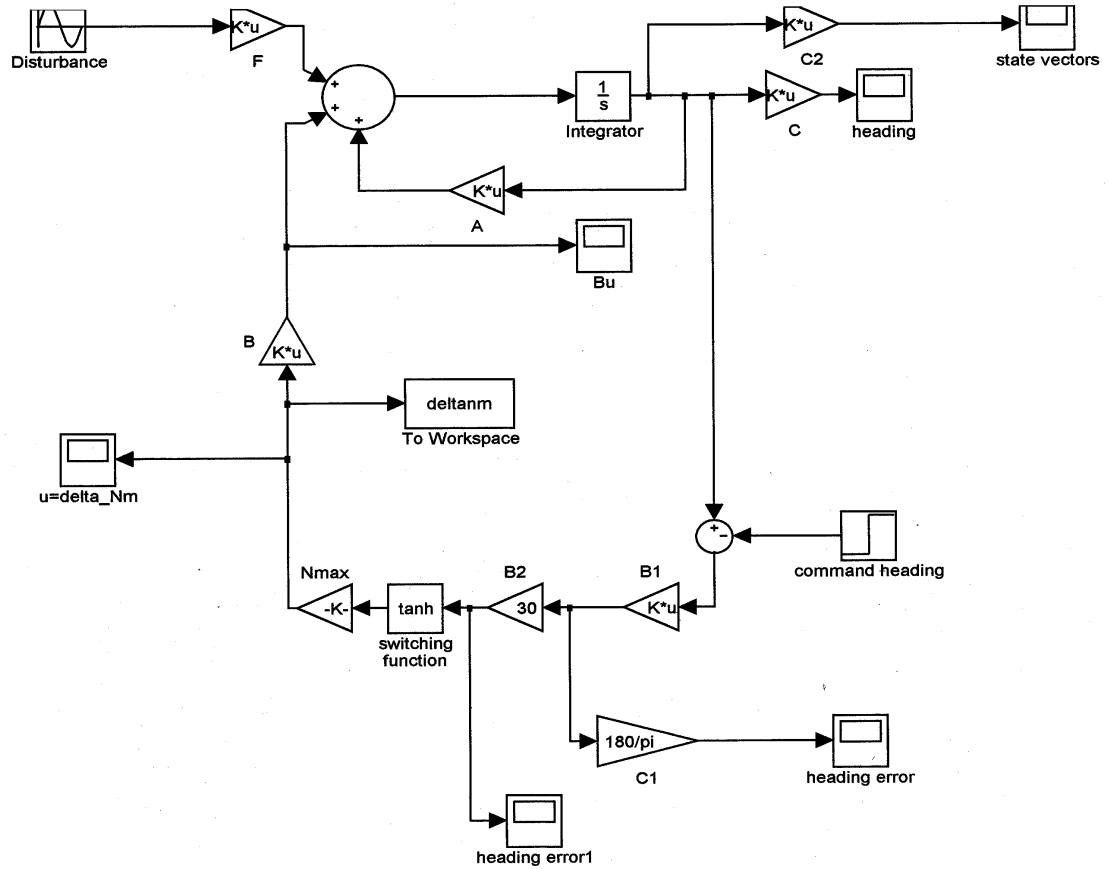

Figure 2 SIMULINK diagram of proportional control

Two control modes, sliding mode and proportional, both making use of differential thrust were used to try and steer ARIES on the surface. The following sections document the experimental results and compare the effectiveness of both control modes.

THIS PAGE INTENTIONALLY LEFT BLANK

III. EXPERIMENTAL TESTING AND RESULTS

A. PROCEDURE

The sliding mode and proportional control codes discussed in the last chapter were implemented in the ‘execf.c’ file, and added to the portion of the code executed when ARIES came to the surface to get a GPS update—the ‘GPS popup’ section. In the actual setup, ARIES could update its position as it transmitted information via the satellite link. Refer to the Appendix for the segment of code used to control the thrusters.

Testing involved an extensive experimental setup. The AUV group consisted of two sections: a land group and a sea group. Land setup included a Command Trailer fitted out with radio communications and the laptop computers used to program and monitor the vehicle. Although the vehicle was completely autonomous, program changes could be made in the command trailer and radioed via the radio modem to ARIES without the need for bringing the vehicle back to base for reprogramming. Program changes and track updates could be made in response to any problems or changes that came up.

The maritime portion of the project consisted of a *Boston Whaler*-class vessel equipped with radio antennae for the modem and VHF communicator. The whaler would tow ARIES to the operating area and follow her during runs. The whaler crew could watch the vehicle’s performance and be on hand for any emergencies.

The missions followed a box pattern created in the ‘Track.out’ file with the vehicle coming to the surface for GPS readings. The ‘Track.out’ file simply contained the geographic waypoints that ARIES would follow during its mission along with other operational parameters such as length of GPS reading and cruising depth. During these ‘GPS pop ups’, differential thrust control would be active and the heading measured against the planned track in order to determine the error. Each specific pattern is described in the following sections. All operations were conducted in the Monterey Bay.

B. RESULTS

1. 31 March 2003

The first run used a 300-meter North leg, a 50-meter East leg, and 300-meter South leg. GPS pop ups were scheduled for the North and South legs and were 35 seconds long.

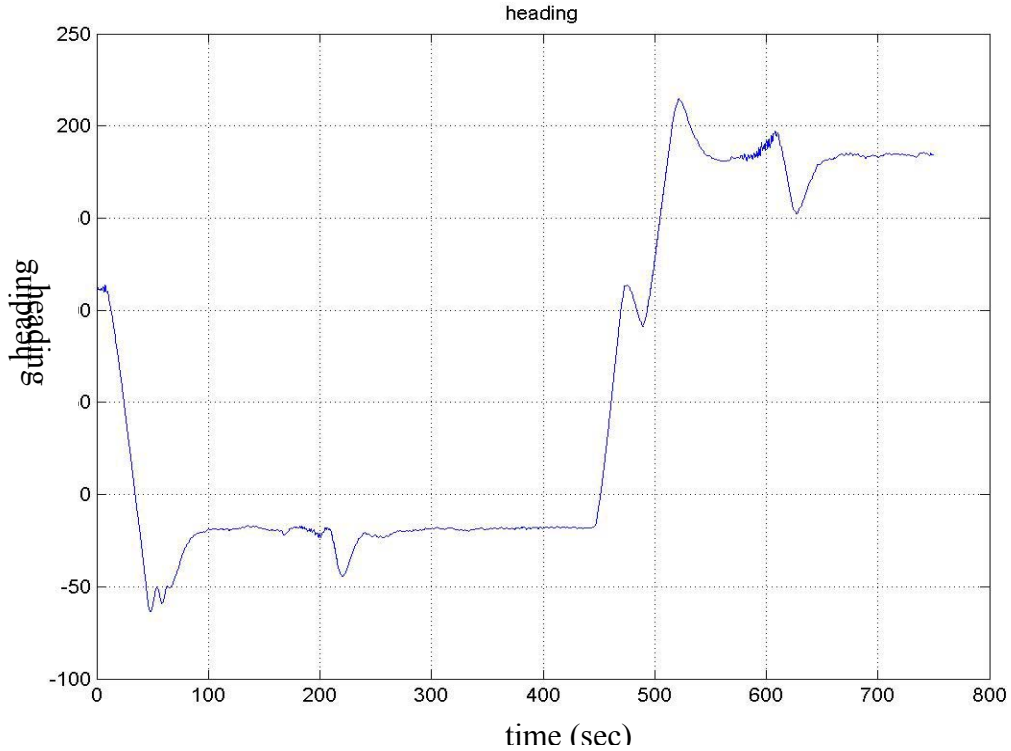

Figure 3 31 March: heading of entire run #1

Figure 3 shows a graph of heading versus time for the first run. The first portion (from 0 to 50 seconds) shows the turn as the vehicle heads to the first waypoint, and each horizontal line represents the north and south legs.

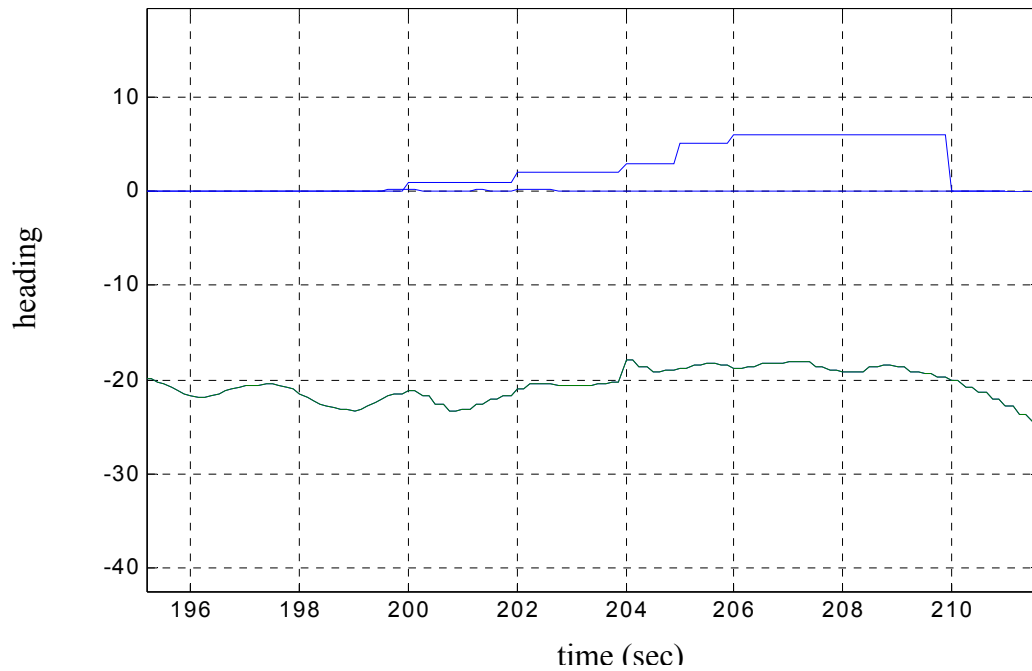

Figure 4 31 March: North run #1; showing number of satellites in blue and heading in green

Figure 4 shows a close in view of the north run. The blue line indicates the number of satellites seen by ARIES and is greater than zero only when ARIES is on the surface. From time 200 to time 210, ARIES is surfaced and remains on a course of -20 degrees or 340 degrees true. This is the course necessary for ARIES to reach the first waypoint.

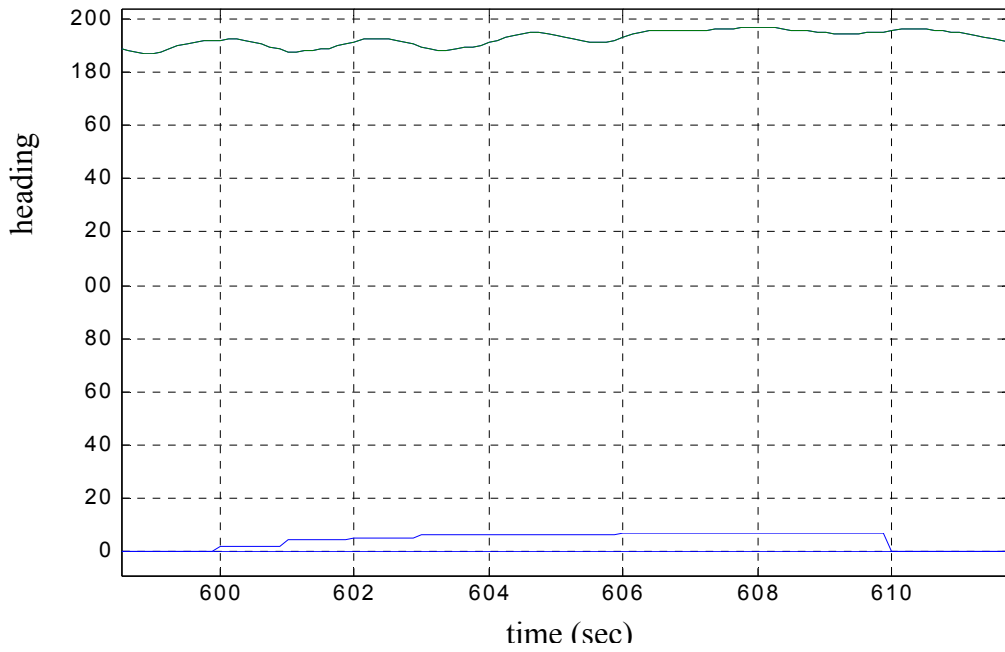

Figure 5 31 March: South run#1; satellites (blue) and heading (green)

Figure 5 shows the southerly portion of the first run and again shows a steady course of 190 degrees.

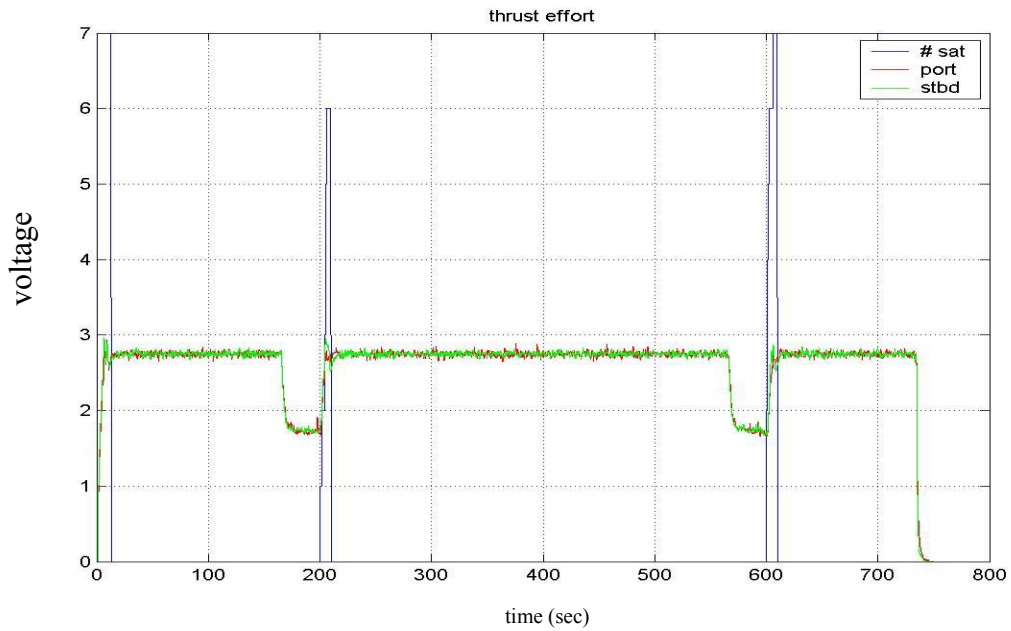

Figure 6 31 March: run#1; thrust effort between port and starboard screws

The thrust effort is shown in Figure 6; note there is no separation between port and starboard thrusters. The control law should have generated a thrust differential and the fact that it does not points to an error in the code.

2. 9 April 2003

Changes were made to the code to amplify the thrust differential. The first run followed the setup for 31 March with the exception that the GPS runs were 70 and 100 seconds long. Table 1 includes a summary of all data from runs made on 9 April 2003.

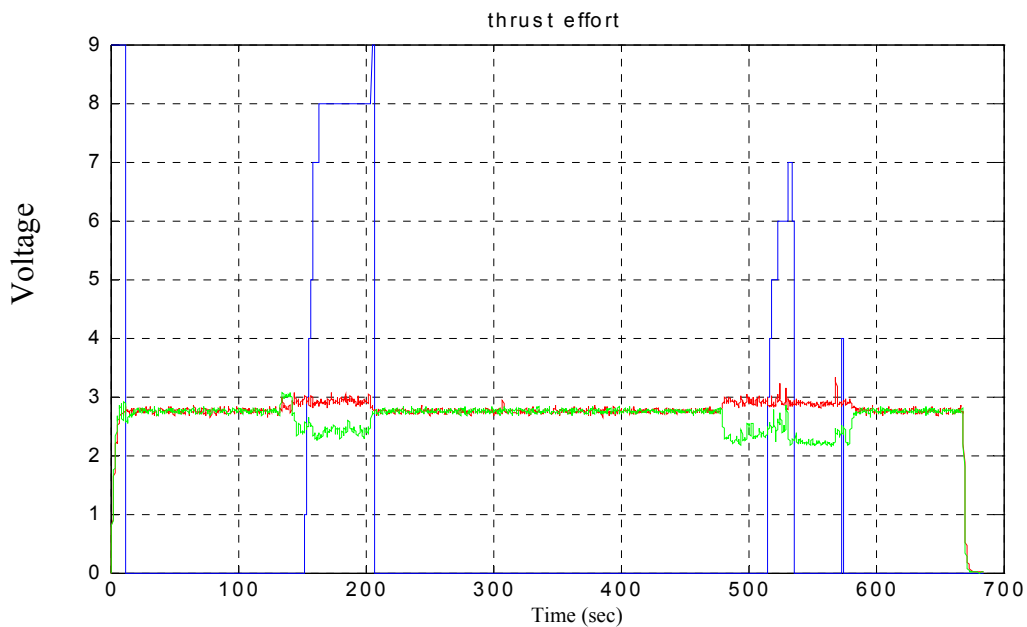

Figure 7 9 April: Run #1; red port thrust (Volts), green starboard, blue number of satellites.

Figure 7 now shows good separation between port and starboard motors as expected.

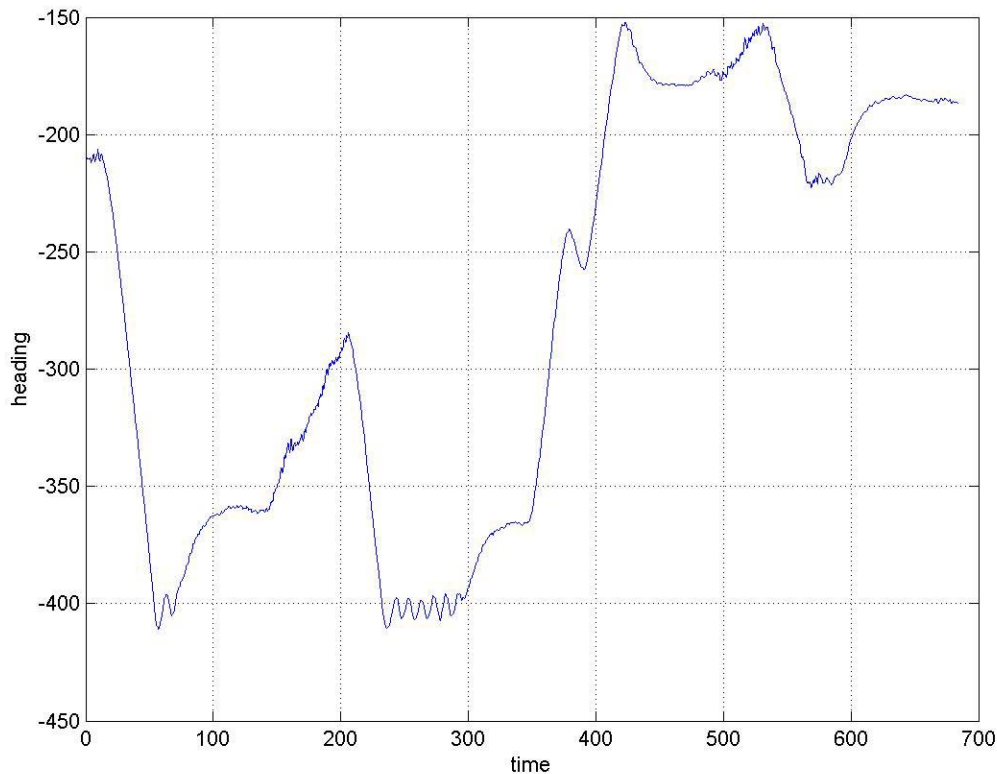

Figure 8 9 April: run #1 heading

In Figure 7, the port thruster is ahead, and Figure 8 shows the vehicle turning to starboard. The vehicle is to the right of course, and the thrusters should generate a negative moment (starboard ahead) to correct. It turns out that since the heading is negative, and the error is determined as the difference between heading and track (see equation (2.1)), the error will always be negative—no matter whether ARIES is to the right or left of track. A negative error will always generate a positive moment, and the vehicle will always turn to starboard as is seen in the figure. The heading measurement was corrected in the May 23rd run as the problem was not discovered until then. The solution is to limit the error between $\pm \pi$ radians so that the vehicle always turns the shortest distance to attain the proper heading.

a. *Second Run*

The second run is set up in the same manner as the first and is included for repeatability.

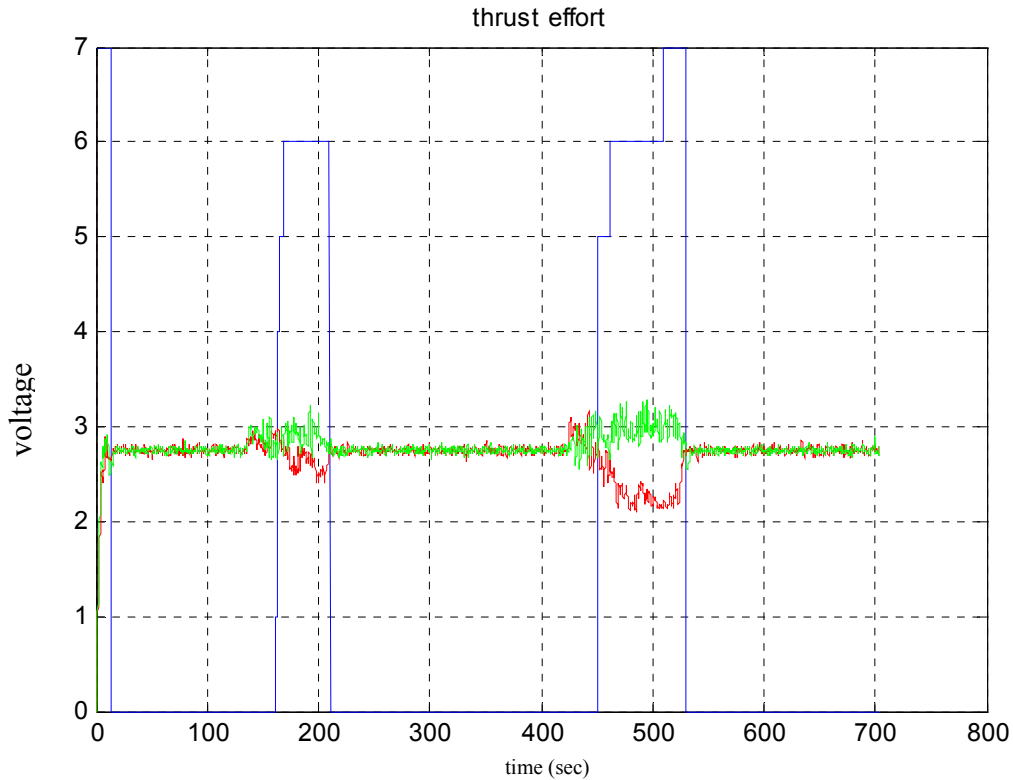

Figure 9 9 April: run #2; red port

In Figure 9, there is again good separation between thrusters showing that the control scheme is putting forth effort to control the vehicle's heading.

In the southerly portion of Figure 10, the vehicle is turning to starboard with the starboard thruster ahead—the thrust is not enough to overcome the wave action pushing against the vehicle, and ARIES turns nearly 180 degrees.

b. Fourth Run

The fourth run consisted of four legs starting north for 300 meters then east for 500 meters, south for 50 meters and then back west for 500 meters. ARIES came to the surface for 30 seconds on the North run, 70 seconds for the east run, and 70 seconds for the western track.

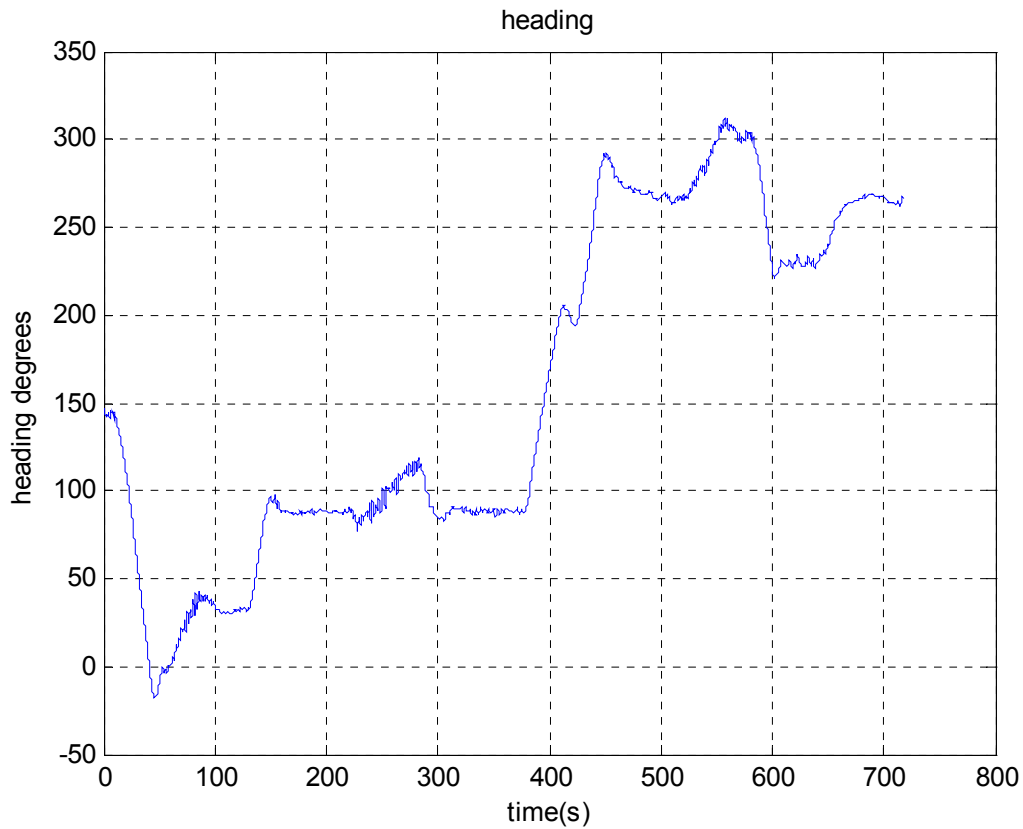

Figure 12 9 April: run #4 heading

In Figure 12, the 090 leg has a positive 30 degree course change on the surface while the western leg changes 40 degrees to starboard. Although Figure 11 shows the thrusters operating to correct heading, the thrusters are ineffective. It is apparent that the motors are not strong enough to overcome wave action.

3. 30 April 2003

The following runs use the proportional controller developed in Chapter II Section D. The vehicle path is a 300 meter North-South by 200 meter East-West rectangular box with GPS pop ups of 50 seconds on each leg. Refer to Table 2 for a summary of the data.

a. First Run

Although this run was entirely underwater due to an error in depth control, it actually brings to light some useful data. When the differential thrust mode is active, the turn rate of the vehicle increases greatly as can be seen in Figure 13. The motors generate enough moment to turn the vehicle while it is underwater and unaffected by waves.

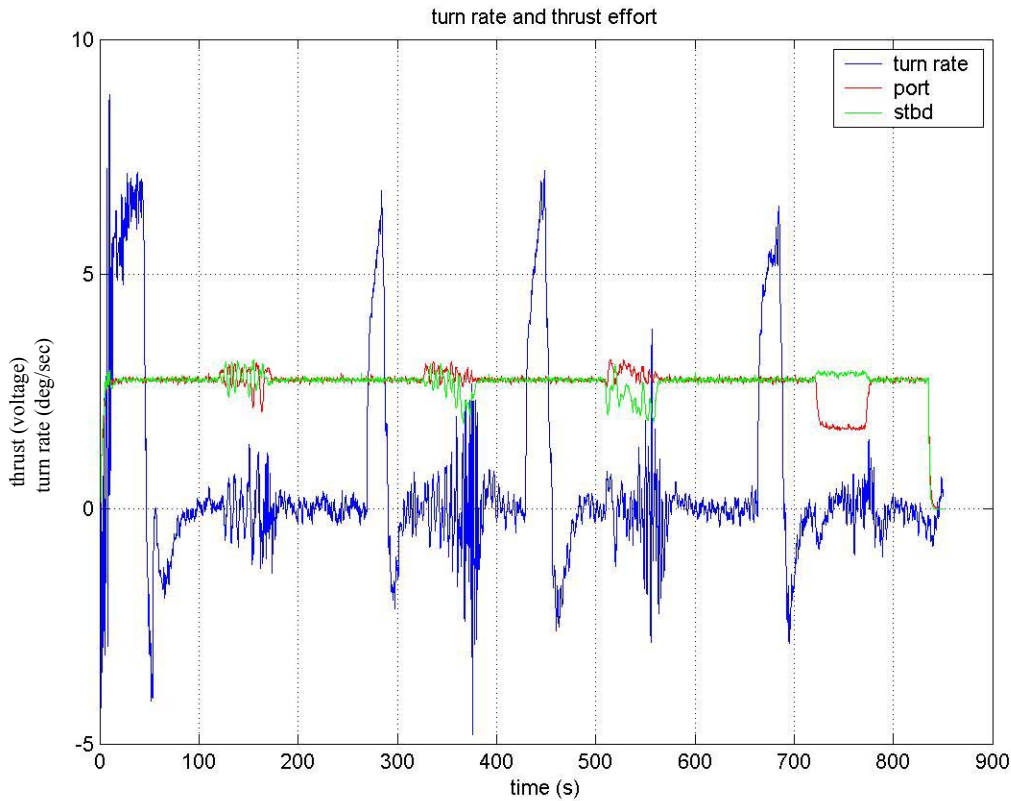

Figure 13 30 April #1 turn rate and thruster voltage

b. Second Run

As we were having trouble controlling depth, it was set to zero for all of runs two and three. Because of its depth, ARIES picks up satellites for most of the run even though there were only four scheduled GPS readings. The only sections of interest for this thesis, however, are the sections of thrust control noted by the diverging red and green lines in Figure 14 and Figure 18.

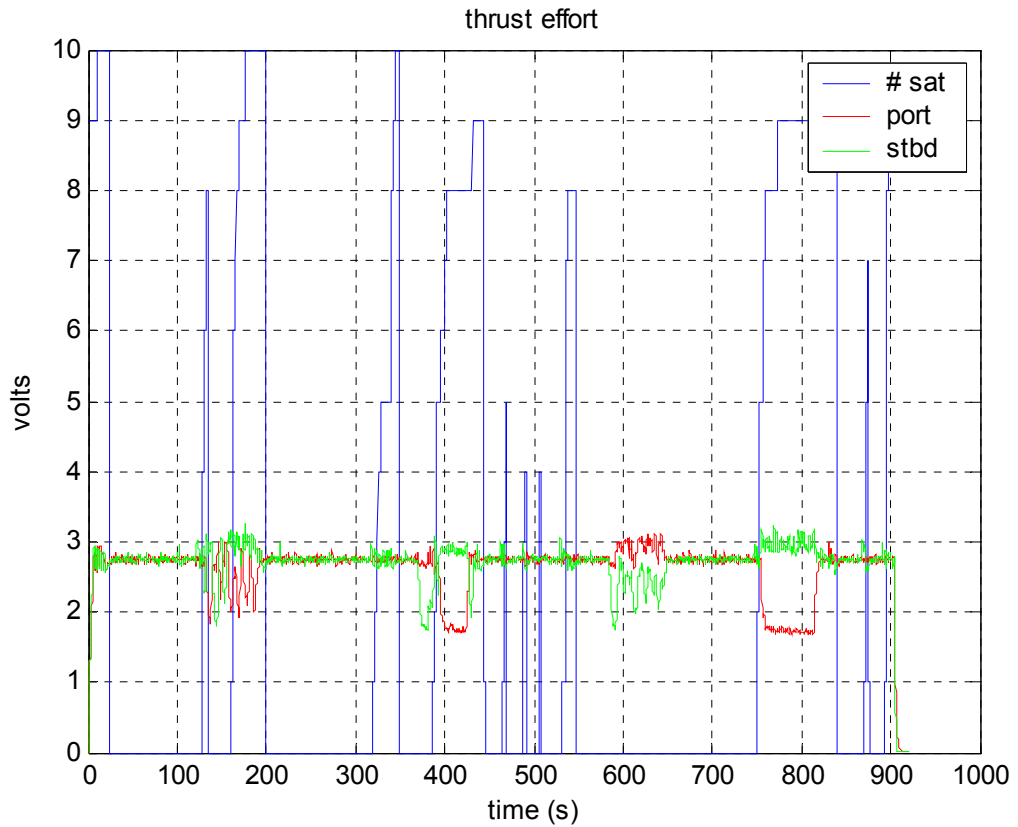

Figure 14 30 April: run #2

Note for the third GPS reading in Figure 14, ARIES did not make it to the surface and thus sees no satellites.

Figure 15 shows the heading throughout the entire run. The east leg is bounded within ten degrees of ordered course, which is well within communication parameters, while the west leg is stable although offset by thirty degrees. For a closer view of the north run, refer to Figure 16.

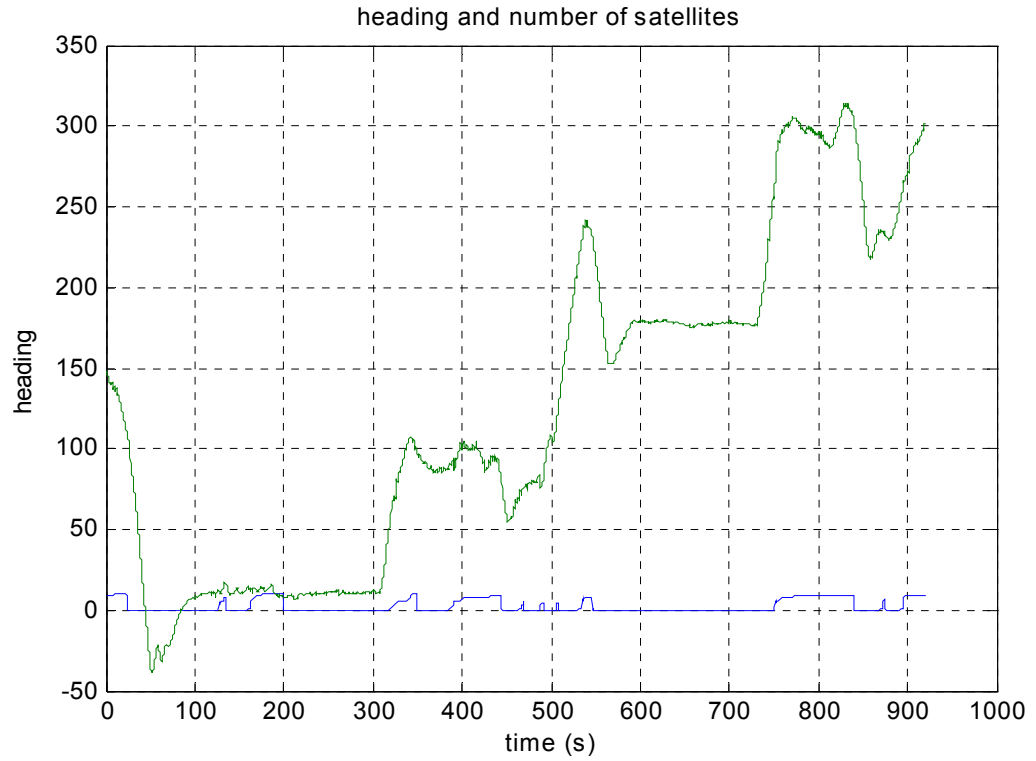

Figure 15 30 April: run #2; the heading is in green while the number of satellites in blue

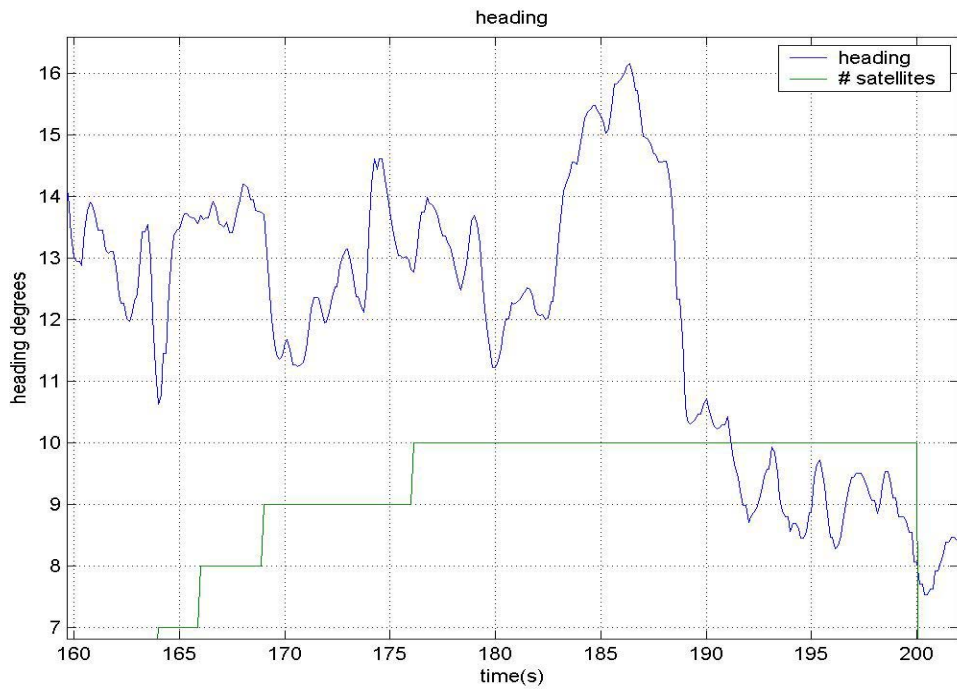

Figure 16 close up view north portion of second run

As can be seen in Figure 16, the north leg is very stable. Although it seems very uneven, the small scale magnifies the wave action; the course only varies 4 degrees to starboard and 4 degrees to port from the average course of 012.

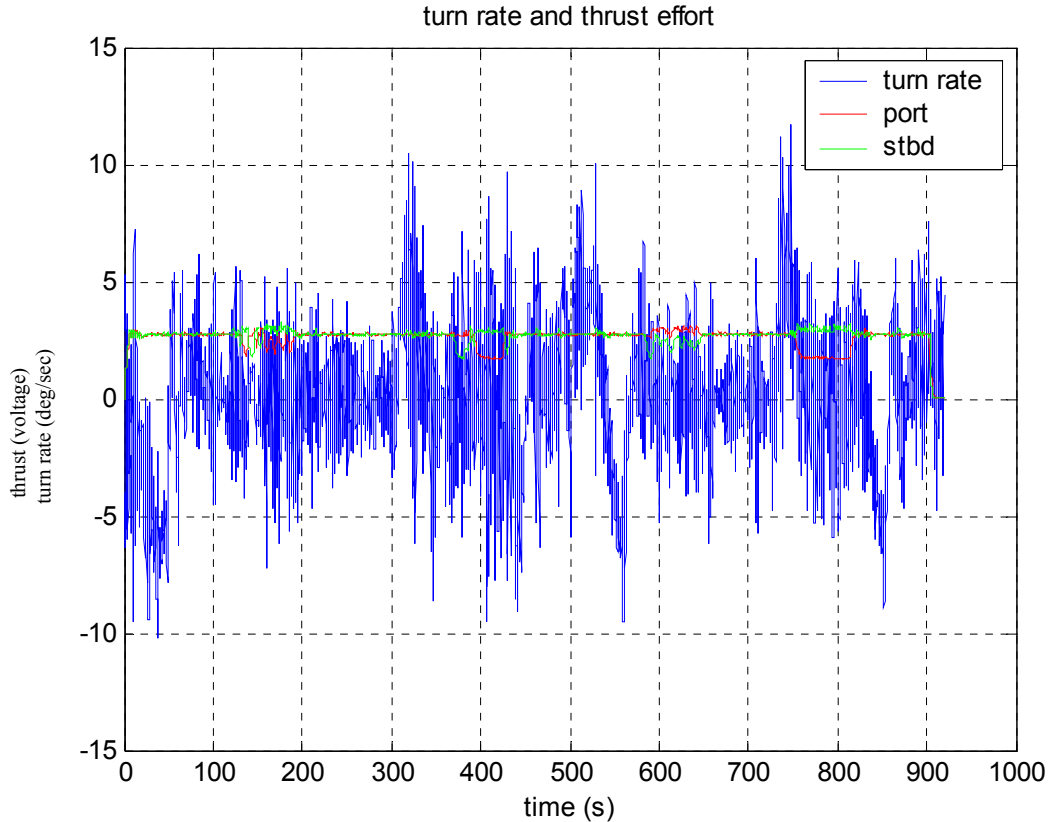

Figure 17 30 April: run #2

The turn rate in Figure 17 is problematic as it is almost always positive even when the starboard thruster is ahead—which should generate a negative turn rate. This shows that the wave action is too strong for the thrusters to overcome no matter which direction the vehicle is heading.

c. Third Run

To ensure repeatability, a third run with the same parameters as the second was added.

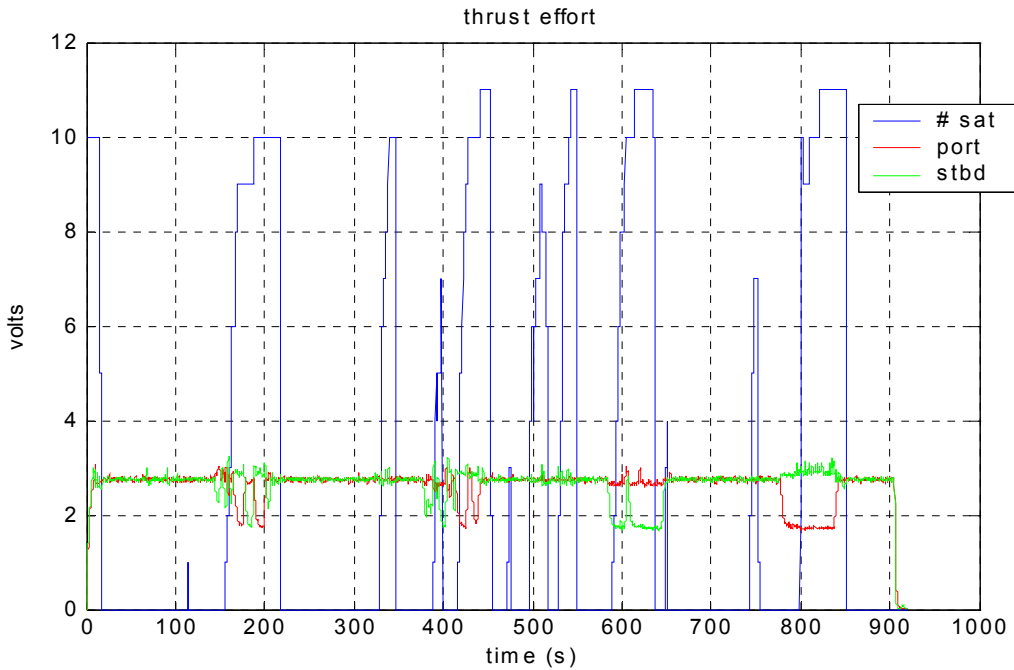

Figure 18 30 April: run #3

Again we see in Figure 18 that a large portion of the run is on the surface, but the main points of interest are the four pop ups where differential thrust control takes over.

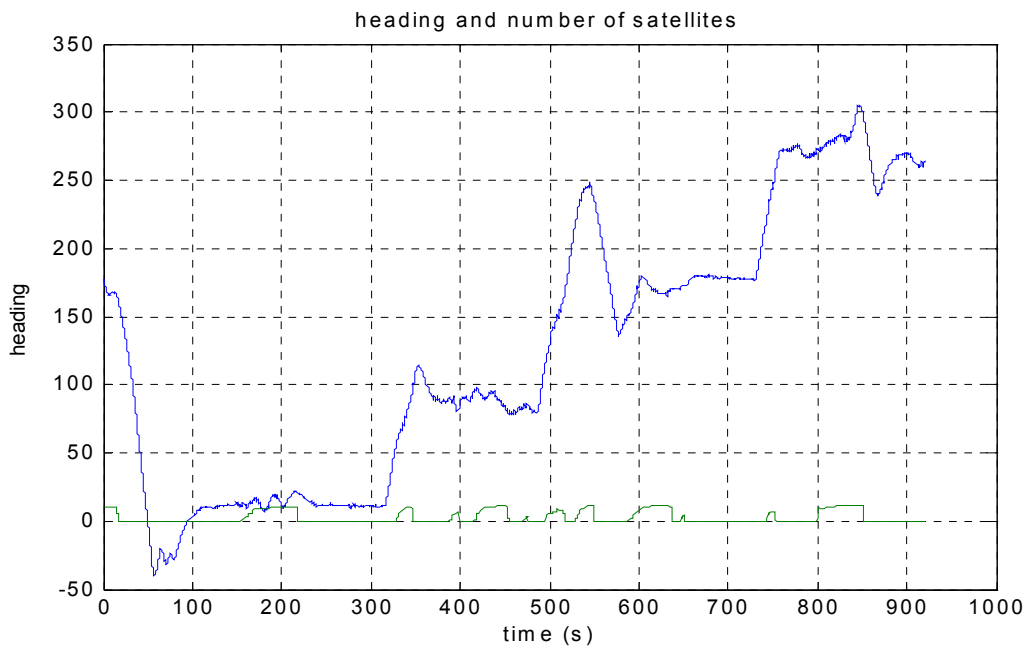

Figure 19 30 April: run #3

On the way to the first waypoint, ARIES steers a course of 014 but varies by 16 degrees as is shown by the oscillation in Figure 19. ARIES maintains an average course of 090 and 170 for the east and south runs, respectively, but varies nearly 20 degrees for the east run and nearly 30 degrees for the south run. Heading is not maintained for the west run where the maximum error is over 30 degrees as is seen in Table 2.

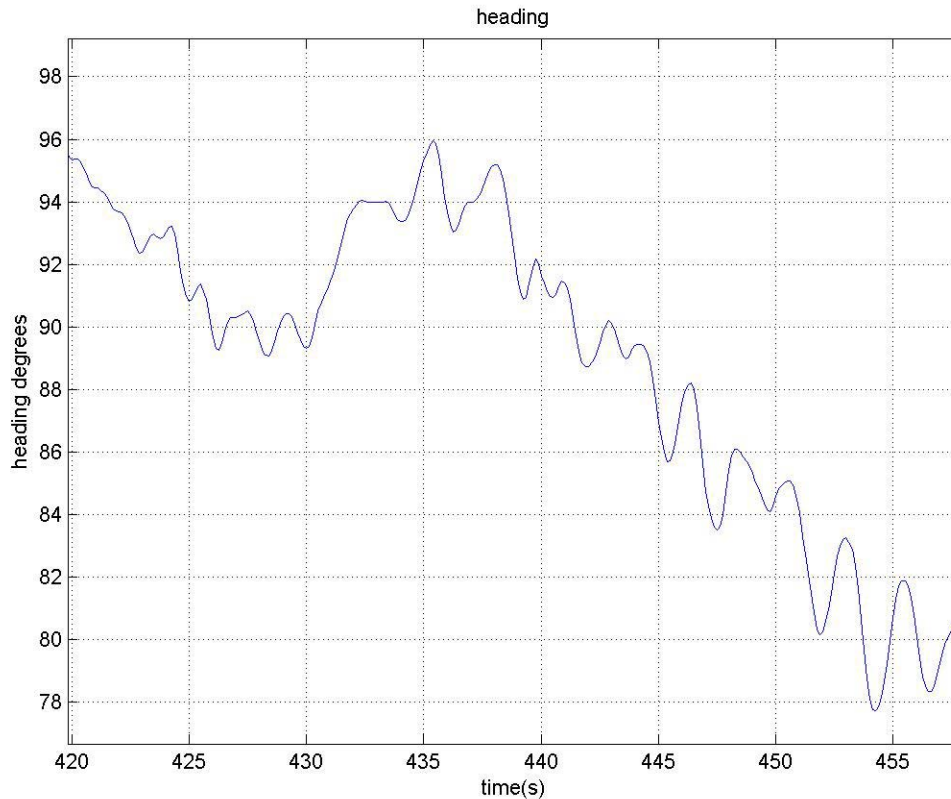

Figure 20 East portion of run #3

The average heading in Figure 20 is 090 degrees, and the course varies by 12 degrees to port and 6 degrees to starboard, which is inside the acquisition range of the C-band antenna.

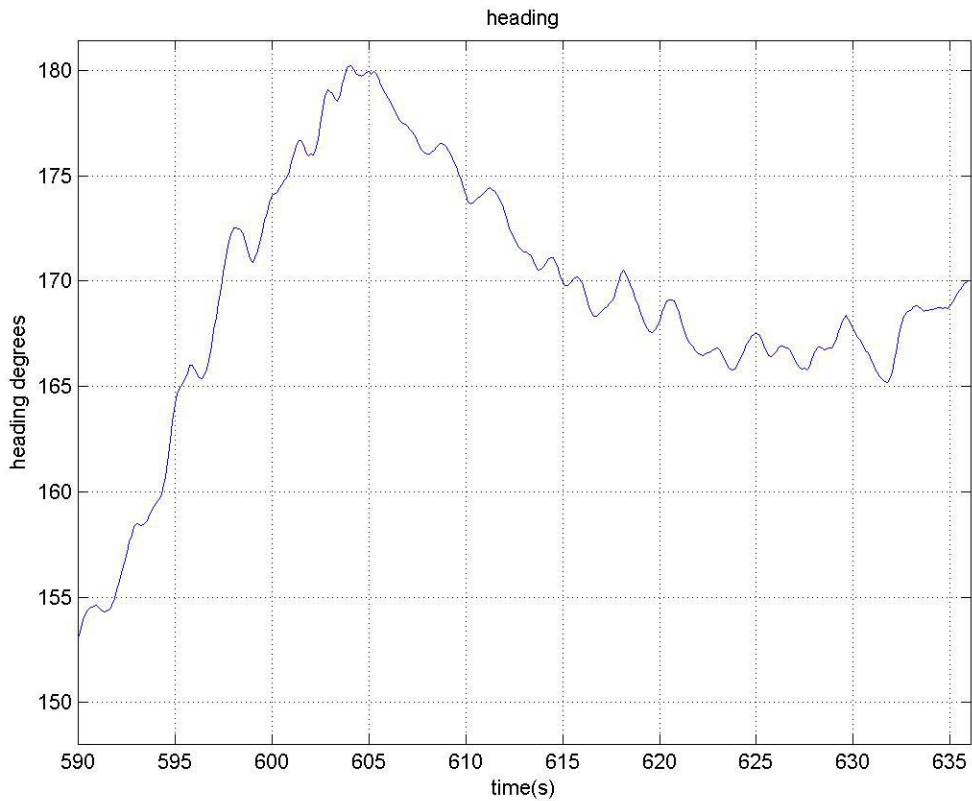

Figure 21 South portion of run #3

The southerly leg in Figure 21 averages 170 degrees, which is within parameters, but it varies by nearly 30 degrees (10 to starboard and 18 to port) during the course of its run. Although this is still within the beamwidth of the antenna, it is a very large deviation and not indicative of good control.

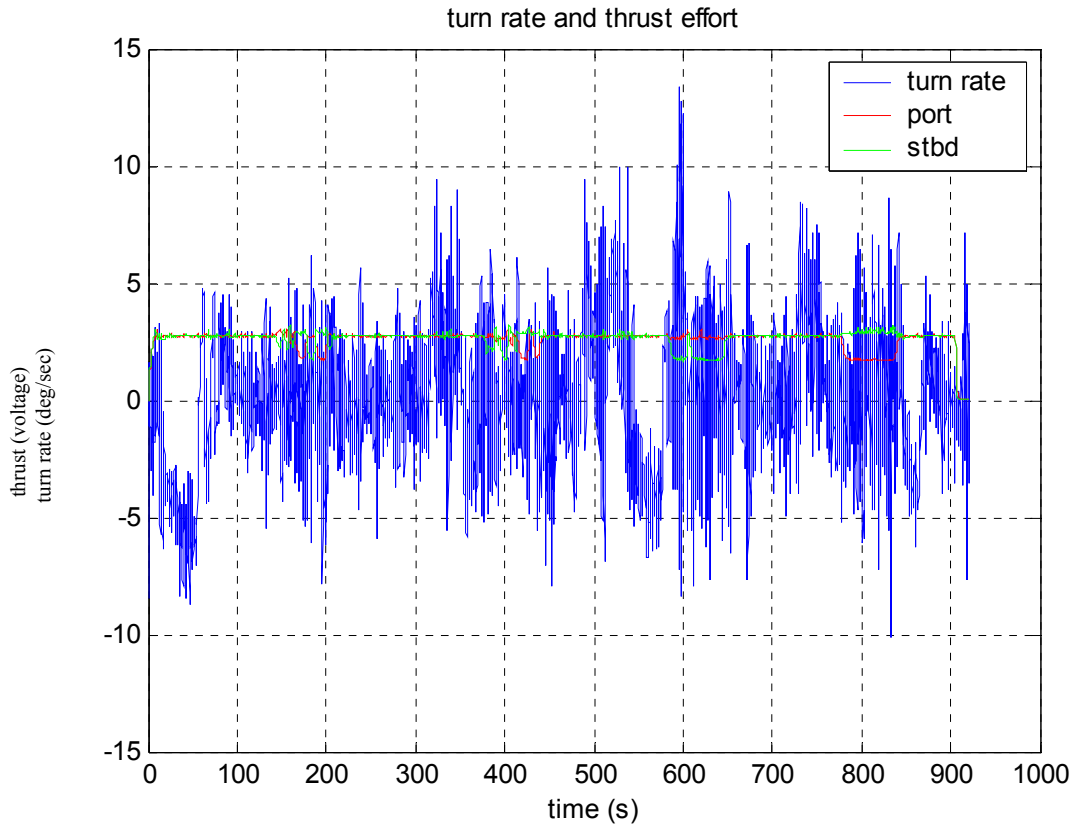

Figure 22 30 April: run #3

The turn rate is again mostly positive as shown in Figure 22 despite thruster orders to the contrary. Once more, this supports the conclusion that the thrusters are not powerful enough to compensate for the wave action.

4. 9 May 2003

For this run, there were two to three foot waves, and this greatly affected ARIES' performance. The rudders were set to zero while surfaced in order to isolate the action of the thrusters. Table 3 contains the results.

In the control code ('execf.c'), the moment coefficient was changed to

$$\text{delta_newtons} = \text{delta_nm} * 6.5617 / 2.0$$

in order to better reflect ARIES' width of 24 inches (0.6 m) The term *delta_newtons* is the force differential in Newtons and is defined as $\text{delta_newtons} = \text{port_thrust} -$

starboard_thrust. The term *delta_nm* is the moment (Newton-meters) generated by the differential thrust.

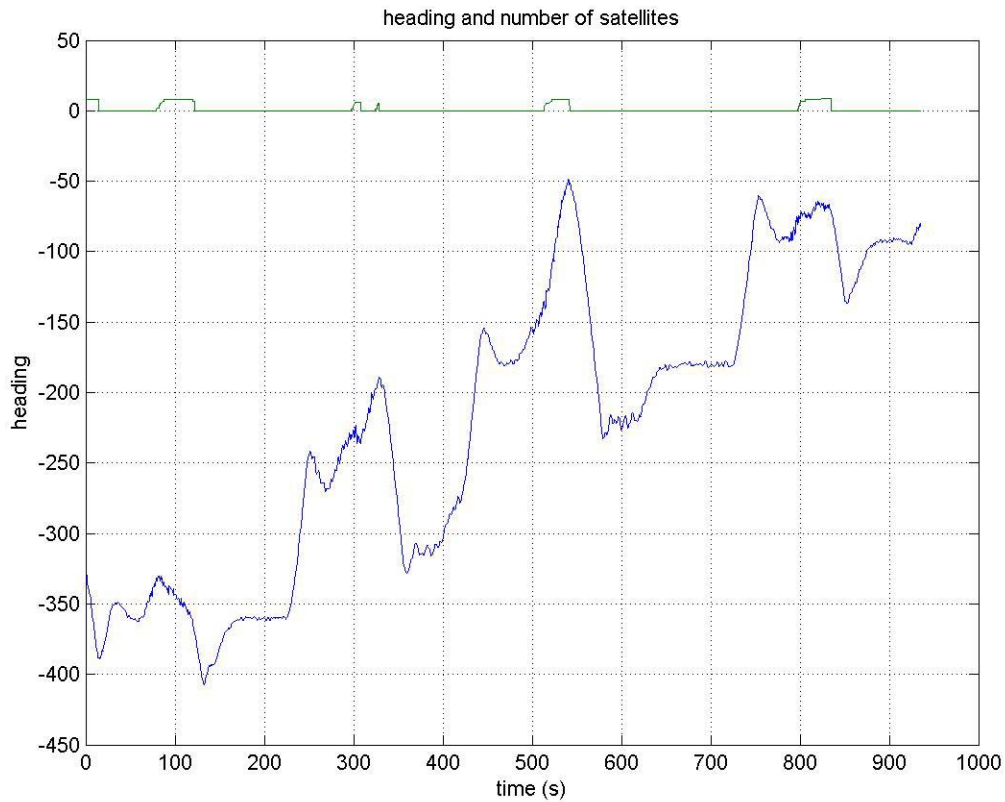

Figure 23 9 May: heading for entire run and number of satellites

Figure 23 shows the heading increasing to starboard for every GPS popup. This was due largely to the ‘wrapping’ error. Since ARIES determined the heading to be negative, the errors for the north, east, and south portions were all negative and thus all moments positive. The exception was the western run where the desired track was -90 degrees. Here, the error was positive, and the motors generated a negative moment. The turn rate, however, was still positive (refer to Figure 25) because of the waves, and thus the vehicle still turned to starboard though not as much.

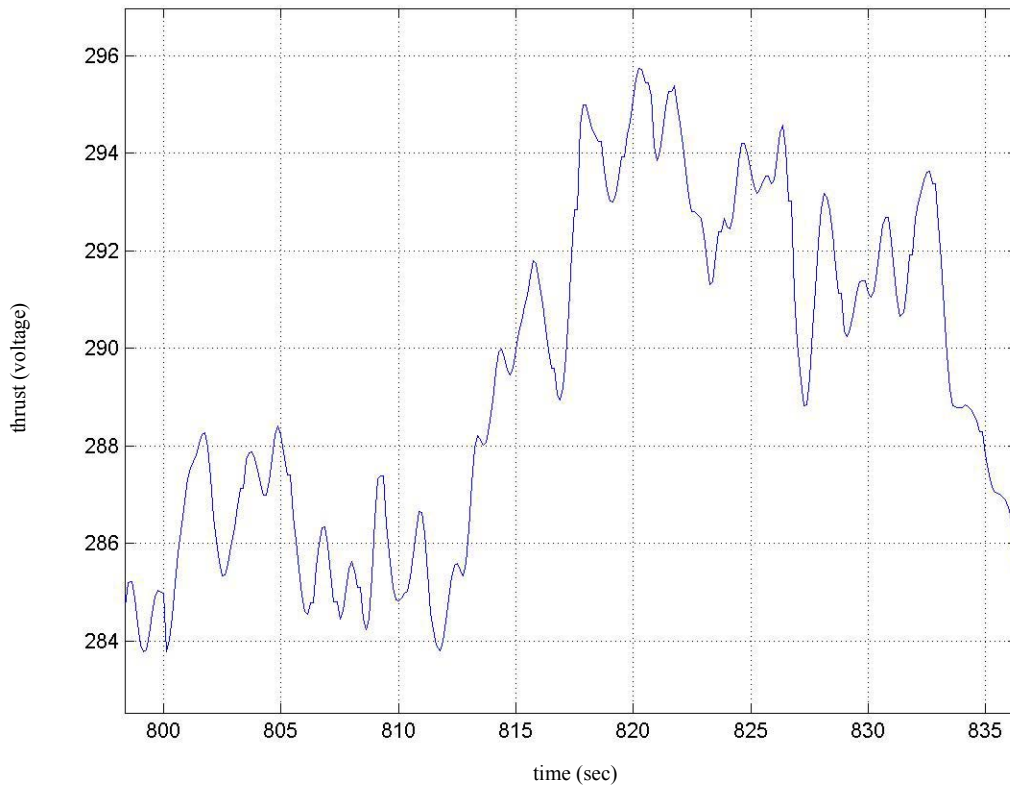

Figure 24 9 May; western track heading

Figure 24 shows the heading varying by only 12 degrees during the western portion of the run, but the course itself is offset 14 degrees from the desired course of 270. Even at maximum thrust, the thrusters are not enough to counteract waves and current; another means of control is required. The data included in Table 3 once again shows that ARIES cannot maintain heading while on the surface in anything other than calm days.

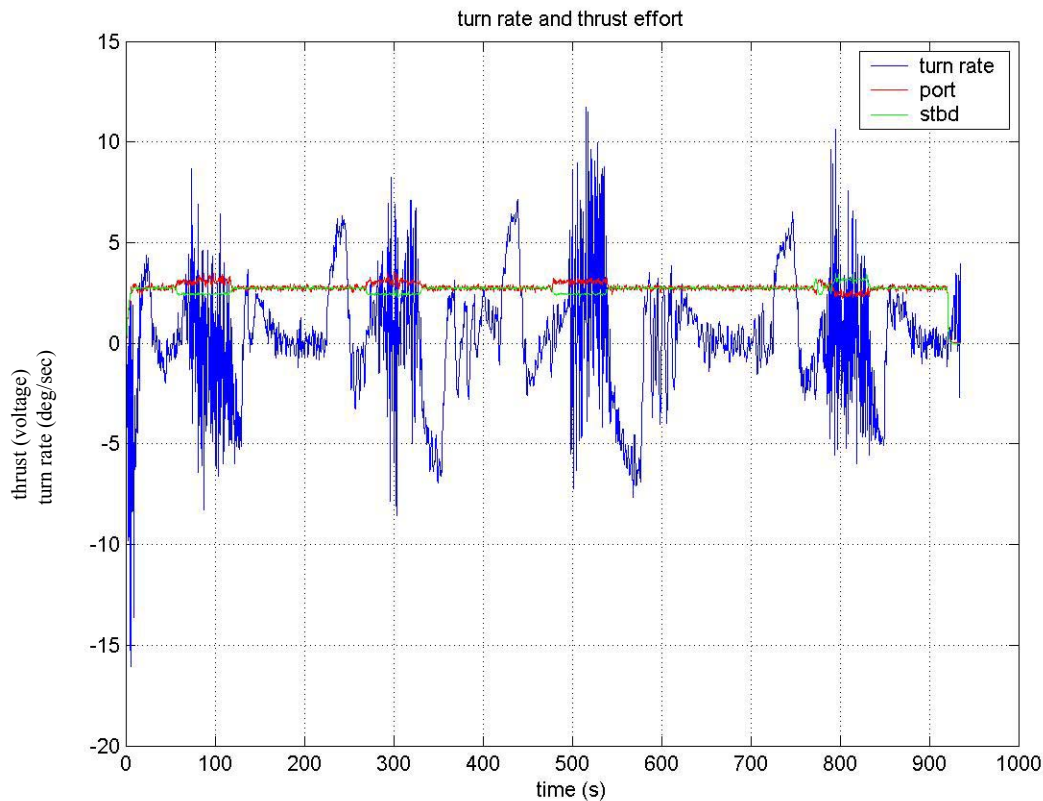

Figure 25 9 May: turn rate and thruster voltage

The first and last GPS runs in Figure 25 show the uncontrollability due to waves. The first section has the port thruster ahead and should result in a positive turn rate but is instead negative; likewise, the last section shows the starboard thruster ahead yet has a positive turn rate.

Analysis of the control code determined that due to the continuous wrapping of heading, errors arose when determining heading differential using equation (2.1). A heading of -360 (as in Figure 23 for the north portion of the run), for example, would always show a negative error even if the vehicle was to the right of intended course. A negative error would call for a positive moment and would drive the vehicle even farther off course. This could easily be fixed by ‘unwrapping’ the heading and keeping it between $\pm \pi$ and is done so in the next run.

5. 23 May 2003

For the final run, all rudders and planes were set to zero during the GPS portion of the track. The depth was set to 3 m for entire run in order to test thruster controllability without any interference by waves.

It was found that the moment coefficient was too weak to steer the vehicle and was changed back to its original form

$$\text{delta_newtons}=\text{delta_nm}*6.5617$$

This corresponds to doubling the moment gain.

The heading error discussed in the previous section was ‘unwrapped’ to $\pm \pi$. ARIES would now take the shortest direction in a turn and would not drive in a direction opposite to where it was supposed to go. Table 4 shows that the results are much more manageable.

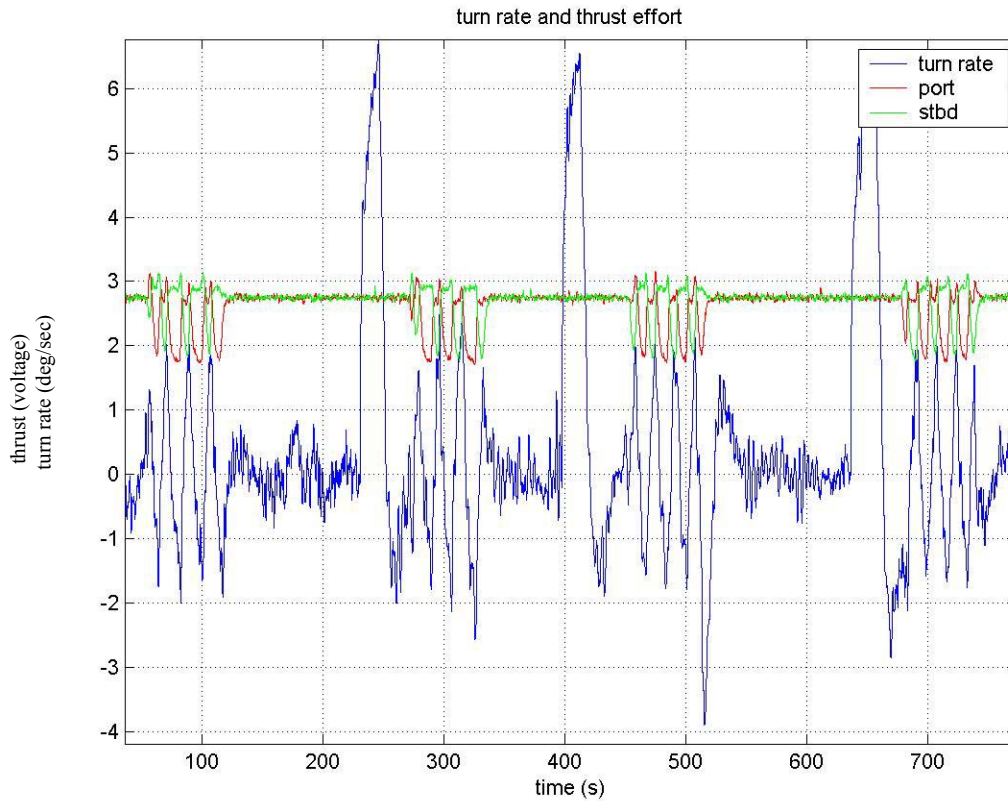

Figure 26 23 May: turn rate and thruster voltage

This run was mainly used to test underwater controllability without rudders. With no wave action to interfere, we are trying to see if the thrusters could steer a straight course. If ARIES maintained course, it would prove that the thrusters and control code were working but were not powerful enough to perform on the surface and deal with wave action. Figure 26 shows that the turn rate increases dramatically when the thrusters come online but hovers around 0 degrees/sec. meaning ARIES steers a straight course. This is confirmed in Figure 27 as well.

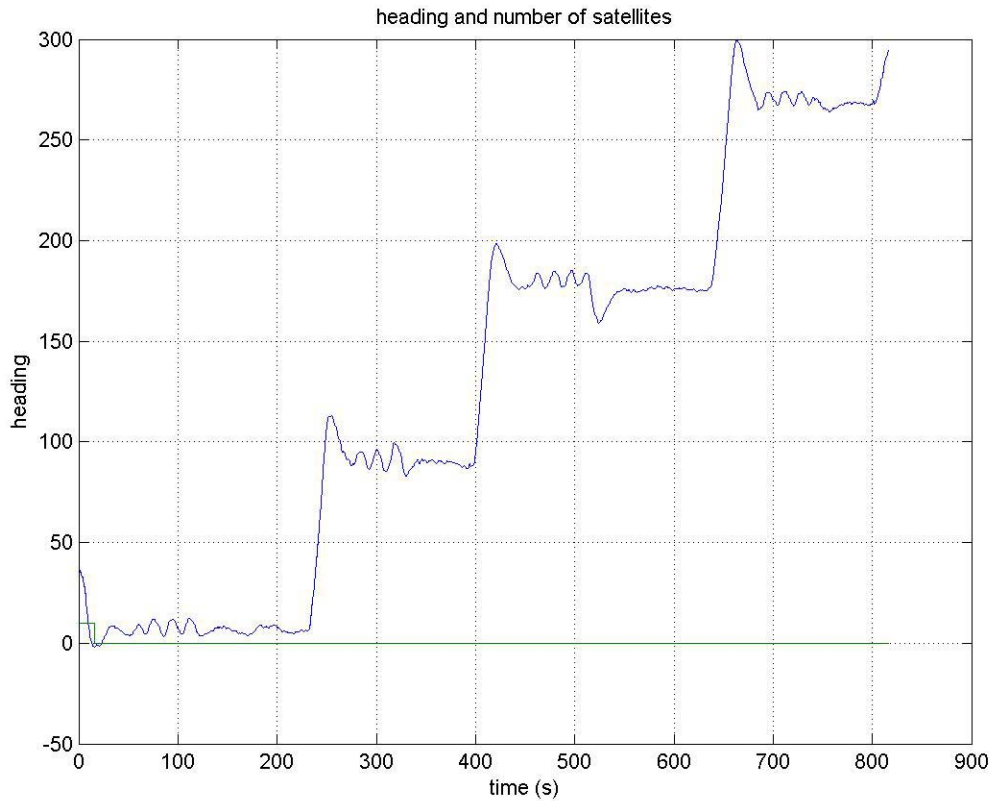

Figure 27 23 May: heading for entire run

The heading varies slightly but is otherwise stable during each of the differential thrust sections. A close up of each run is examined to demonstrate their stability.

Figure 28 shows the easterly heading stays around 090 degrees and only varies 10 degrees to starboard and 6 degrees to port—well within communication range. Unfortunately, since this entire run is underwater and is only used to test ARIES’ responsiveness to differential thruster thrust it does not help satellite communications.

The average heading in Figure 29 is 180 degrees and only varies by 5 degrees to starboard and 4 degrees to port.

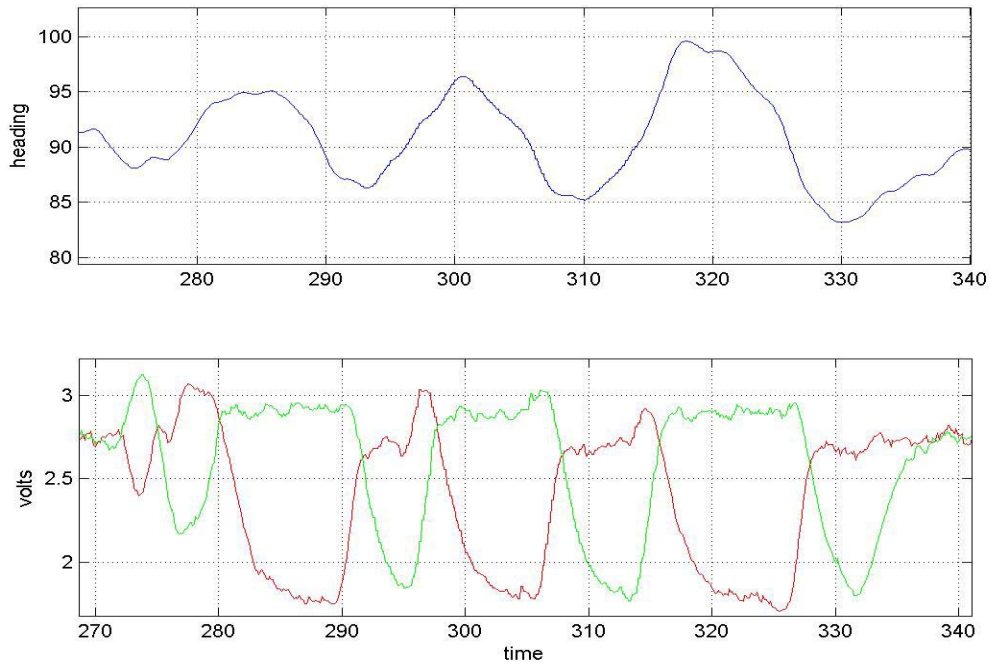

Figure 28 23 May: heading and thruster voltage for east leg; port thruster is red, starboard is green

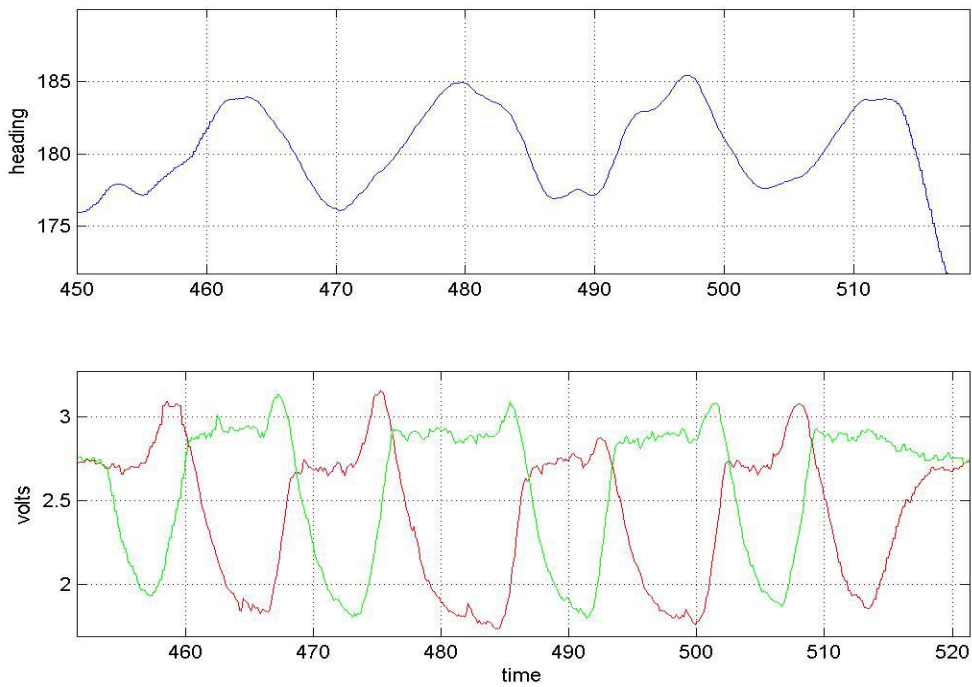

Figure 29 23 May: heading and voltage for south leg

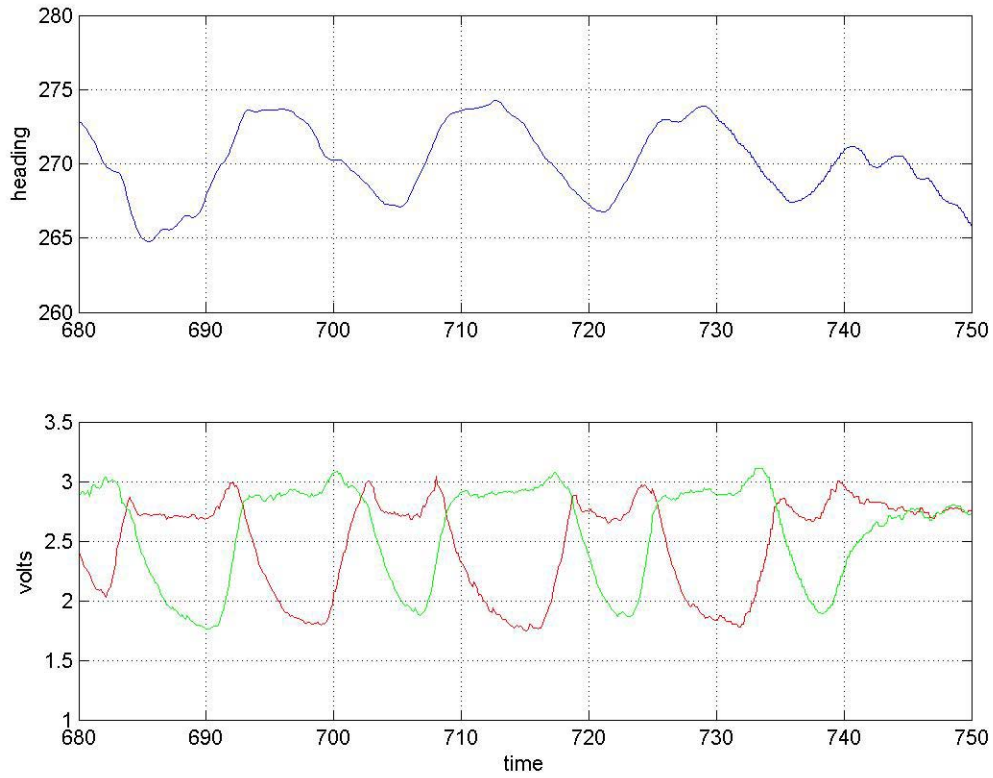

Figure 30 23 May: heading and voltage for west leg

Figure 28 through Figure 30 show that the ‘wrapping’ error has been solved. The thrusters act properly to correct the heading—generating a negative moment when the heading is to the right of track and a positive moment when the heading is to the left of track.

In this section, we tried both sliding mode and proportional control modes to achieve heading control. Despite correcting the way the error was measured, it does not change the fact that the thrusters are too weak to exert any control. ARIES has no reliable control while on the surface and subject to wave action. The data conclusively proves that the motors cannot match the force of the waves.

C. TABLES OF RESULTS

The following tables contain the results of the experiments organized by date. When several runs were accomplished on the same day, they are included in separate columns. Each run is further broken down into the four cardinal directions. The maximum error of the run was calculated by subtracting the smallest heading from the largest. The standard deviation is found using standard mathematical practices, and the average course is a time average of the vehicle's heading. When there is no data for a particular heading, either that heading was not part of the experiment (as in earlier runs with only North-South or East-West runs) or ARIES did not make it to the surface and thus gathered no data.

Table 1 Data results for 9 April 2003

9 APR	run1	run2	run4
North			
maximum error	55	14	in a turn
std deviation	16.5	3.8	
average course	45.9	12.5	
East			
maximum error			27
std deviation			8.9
average course			103.3
South			
maximum error	7		
std deviation	2.6		
average course	202.9		
West			
maximum error			37
std deviation			10.8
average course			296.7

Table 2 Data results for 30 April 2003

30 APR	run2	run3
North		
maximum	8	16
std deviation	2.1	3.9
average course	12.1	14.5
East		
maximum	25	-17
std deviation	5.6	4.0
average course	95.7	90
South		
maximum	submerged	29
std deviation		6.1
average course		169.3
West		
maximum	in a turn	33
std deviation		9.1
average course		283.1

Table 3 Data results for 9 May 2003

9 MAY	run2
North	
	maximum: 37.5
	std deviation: 9.2
	average: 15.4
East	submerged
South	
	maximum: 92.3
	std deviation: 30.0
	average course: 268.6
West	
	maximum: 12.0
	std deviation: 3.4
	average course: 289.7

Table 4 Data results for 23 May 2003

23 MAY	
North	maximum: 9.1
	std deviation: 2.6
	average: 8.2
East	maximum: 16.4
	std deviation: 4.3
	average: 90.9
South	maximum: 9.3
	std deviation: 2.7
	average: 180.8
West	maximum: 9.5
	std deviation: 2.5
	average: 270.3

IV. CONCLUSIONS

A. CONTROL MODE CONCLUSIONS

As seen in the Chapter III, sliding mode control was saturated by the wave motion and could not provide adequate control. In general, the control scheme did not work as the vehicle always turned to starboard despite any control effort by the motors. When the thrusters were operating in the correct direction to counter the vehicle's movement, they did not provide enough control effort to make any difference.

Proportional control was much better but still not good enough to overcome the waves. The control code directed the thrusters in the proper direction to counter the waves and was not saturated by the wave frequency due to the filtering of the hyperbolic tangent function. The small motors, however, were not enough to handle rough seas and wave buffeting.

It was critical for both feedback methods that the heading error be bounded between ± 180 degrees in order to get ARIES to make the shortest turn. Without this limit, ARIES would sometimes turn to starboard even though it was to the right of track. The motors were acting to correct the heading, but they were taking the long way around the circle.

When the vehicle was completely underwater and not subject to wave action, the differential control performed admirably. Unfortunately, satellite communications are impossible while underwater. The success with controlling the heading using only thrusters, however, proved that they could act as a backup should the rudders fail.

B. RECOMMENDATIONS FOR FURTHER WORK

It is the assertion of this thesis that ventral rudders are necessary to control the vehicle while on the surface. Another study should be performed to check the feasibility of rudders and determine the control code necessary to steer the vehicle. An additional method to overcome surface control problems would be to design and build a movable antenna. This would solve the problem of the thrusters being too weak and place control

responsibility on the motor turning the antenna. This motor would have to compensate for wave action moving the vehicle, but the motor would not have to be strong enough to resist waves, only fast enough to respond to them and keep the antenna pointing within thirty degrees of the target satellite.

A further possible fix includes stronger motors. The motors currently mounted on ARIES can control the vehicle when it is underwater; if they were stronger, perhaps they could counteract the wave forces pushing ARIES off course. An analysis of the problem would have to determine how strong the thrusters needed to be and see if it were feasible to mount such thrusters on a small underwater vehicle such as ARIES. Price would have to be considered as well as it might be less expensive to install lower rudders. Whatever the method used to control ARIES while on the surface, the current method of differential thrust is of insufficient strength to handle the task.

APPENDIX

'ENGINE5.M'

```
%SI
rho=1025;
L=3;
b=16*.0254;
T=10*.0254;
U=1.5; % m/s
area=T*b;
thrust=0.1*rho*area*1.5^2; %N
width=23*.0254/2;
diam=6*.0254;%propeller diam in m
%Prof Healey inputs
%Jay Johnson Model
% SI
Yv=-68.16;
Yr = 406.3;
Ydr=0;% for thrust control
Nv = -10.89;
Nr = -88.34;
Ndr=0; %for thrust control
MY = 456.76;
IN = 215;
% initial wave estimation
```

```

Ywave=-.5; % Newtons

Nwave=-.5*(L/2); % Newton-meters

% wave=sin(pi*t); % modeled as sin wave period 2s

%mass matrix

%  $M\dot{x}=A*x+B*u+F*d$ 

%  $\dot{x}=\text{inv}(M)*A*x+\text{inv}(M)*B*u+\text{inv}(M)*F*d$ 

%u is in Nm

M=diag([MY,IN,1]);

AA=[Yv,Yr,0;Nv,Nr,0;0,1,0];

A=inv(M)*AA;

BB=[0; 1; 0]; B=inv(M)*BB;

F1=[1 0; 0 1; 0 0];

F=inv(M)*F1;

d=[Ywave; Nwave];

% [A_dt B_dt]=c2d(A,B,.125);

% [A_dt F_dt]=c2d(A,F,.125)

eta=1;

C=[0 0 180/pi]; %convert to degrees

Nmax=1.3; %proportional controller (Nm)

% %sliding mode control

J=[0 , -.2, -.4]; %rad/s

K=place(A, B, J);

Acl=A-B*K;

[V,D]=eig(Acl');

```

```

s=V(:,3); %eigenvector corresponds to 0 eigenvalue (D)
% u=k1*(x-xcom)+k2*satsgn(k3(x-xcom)/phi)
K1=-inv(s'*B)*s'*A
%K1(1)=0; % no sway control
%K2=-inv(s'*B);
K2=-10 %adjustable
K3=s'
%K3(1)=0; % no sway control

```

'EXECF.C'

(GPS Portion)

```

if(GET_GPS_FIX == TRUE)

psi_errorDIF=psi_cont-SegPsi;

while(fabs(psi_errorDIF) > pi)

{psi_errorDIF = psi_errorDIF - dsign(psi_errorDIF)*2.0*pi;}

delta_nm = -1.3*dtanh(30.0*psi_errorDIF);

delta_newtons = delta_nm*6.5617;

if (fabs(delta_newtons) > 9.0) delta_newtons = 9.0*delta_newtons/fabs(delta_newtons);

v_rs = sqrt((9 - delta_newtons)/1.0314);

v_ls = sqrt((9 + delta_newtons)/1.0314);

if (v_rs < 0.0) v_rs = 0.0;

if (v_ls < 0.0) v_ls = 0.0;

LeftScrewSpeedControl(v_ls);

RightScrewSpeedControl(v_rs);

```

THIS PAGE INTENTIONALLY LEFT BLANK

LIST OF REFERENCES

Gamache, K. A., "Oceanographic DataLink," *IEEE Journal of Oceanic Engineering*, v. 26, no. 4, pp. 622-631, October 2001.

Grub, J. L., "The Traveler's Dream come True," *IEEE Communications Magazine*, pp. 48-51, November 1991.

Healey, A. J., "Multivariable Control Of Ship Systems," class notes for ME4811 taught at the Naval Postgraduate School, 2002.

Healey, A. J., "Dynamics of Marine Vehicles," class notes for ME4823 taught at the Naval Postgraduate School, 2003.

Johnson, J., *Parameter Identification Of The ARIES AUV*, Master's Thesis, Naval Postgraduate School, Monterey, California, June 2001.

THIS PAGE INTENTIONALLY LEFT BLANK

INITIAL DISTRIBUTION LIST

1. Defense Technical Information Center
Ft. Belvoir, Virginia
2. Dudley Knox Library
Naval Postgraduate School
Monterey, California
3. Dr. Y. W. Kwon, Chairman
Department of Mechanical Engineering
Naval Postgraduate School
Monterey, California
4. Dr. A. J. Healey
Department of Mechanical Engineering
Naval Postgraduate School
Monterey, California
5. Dr. T. Swean
Office of Naval Research
Alexandria, Virginia
6. Commander Stanley Cunningham, USN
Department of Mechanical Engineering
Naval Postgraduate School
Monterey, California
7. Lieutenant Chris Sarton, USN
Department of Mechanical Engineering
Naval Postgraduate School
Monterey, California