

# NAVAL POSTGRADUATE SCHOOL Monterey, California



## THESIS

**SHIPBOARD SENSOR CLOSED-LOOP CALIBRATION  
USING WIRELESS LANS AND DATASOCKET  
PROTOCOLS**

by

Steven Joseph Perchalski

June 2003

Thesis Advisor:  
Second Reader:

Xiaoping Yun  
Fotis Papoulias

**Approved for public release; distribution is unlimited.**

THIS PAGE INTENTIONALLY LEFT BLANK

<b>REPORT DOCUMENTATION PAGE</b>			<i>Form Approved OMB No. 0704-0188</i>
Public reporting burden for this collection of information is estimated to average 1 hour per response, including the time for reviewing instruction, searching existing data sources, gathering and maintaining the data needed, and completing and reviewing the collection of information. Send comments regarding this burden estimate or any other aspect of this collection of information, including suggestions for reducing this burden, to Washington headquarters Services, Directorate for Information Operations and Reports, 1215 Jefferson Davis Highway, Suite 1204, Arlington, VA 22202-4302, and to the Office of Management and Budget, Paperwork Reduction Project (0704-0188) Washington DC 20503.			
<b>1. AGENCY USE ONLY (Leave blank)</b>	<b>2. REPORT DATE</b> June 2003	<b>3. REPORT TYPE AND DATES COVERED</b> Master's Thesis	
<b>4. TITLE AND SUBTITLE:</b> SHIPBOARD SENSOR CLOSED-LOOP CALIBRATION USING WIRELESS LANS AND DATASOCKET TRANSPORT PROTOCOLS			<b>5. FUNDING NUMBERS</b>
<b>6. AUTHOR</b> Perchalski, Steven J			
<b>7. PERFORMING ORGANIZATION NAME(S) AND ADDRESS(ES)</b> Naval Postgraduate School Monterey, CA 93943-5000			<b>8. PERFORMING ORGANIZATION REPORT NUMBER</b>
<b>9. SPONSORING / MONITORING AGENCY NAME(S) AND ADDRESS(ES)</b>			<b>10. SPONSORING / MONITORING AGENCY REPORT NUMBER</b>
<b>11. SUPPLEMENTARY NOTES</b> The views expressed in this thesis are those of the author and do not reflect the official policy or position of the Department of Defense or the U.S. Government.			
<b>12a. DISTRIBUTION / AVAILABILITY STATEMENT</b> Approved for public release; distribution is unlimited.			<b>12b. DISTRIBUTION CODE</b> Code A
<b>13. ABSTRACT (maximum 200 words)</b>  This thesis studies the feasibility of developing a closed-loop shipboard sensor calibration system with two main objectives. The first objective was to reduce the number of personnel required to calibrate a shipboard sensor by 50%. The second was to reduce the time required to complete the calibration process by 60%. This was achieved by displaying the sensor data and the calibration standard data on a tablet PC. Wireless technology was used to transmit the data from the sensor and the calibration standard to the tablet PC. The data from the sensor is sent via IEEE 802.11b wireless LAN using DataSocket protocol and the calibration standard is sent via Bluetooth protocol. The technology can be installed and used on current ships in the United States Navy. Four software programs were developed to accomplish these goals. One program runs on the tablet PC and the other three run on the network capable application processor (NCAP). These four programs accomplish the goals stated.			
<b>14. SUBJECT TERMS</b> closed loop calibration, wireless, portable, handheld, 802.11b, Bluetooth, DataSocket.			<b>15. NUMBER OF PAGES</b> 103
			<b>16. PRICE CODE</b>
<b>17. SECURITY CLASSIFICATION OF REPORT</b> Unclassified	<b>18. SECURITY CLASSIFICATION OF THIS PAGE</b> Unclassified	<b>19. SECURITY CLASSIFICATION OF ABSTRACT</b> Unclassified	<b>20. LIMITATION OF ABSTRACT</b> UL

THIS PAGE INTENTIONALLY LEFT BLANK

**Approved for public release; distribution is unlimited.**

**SHIPBOARD SENSOR CLOSED-LOOP CALIBRATION USING WIRELESS  
LANS AND DATASOCKET TRANSPORT PROTOCOLS**

Steven Joseph Perchalski  
Lieutenant, United States Navy  
B.S., United States Naval Academy, 1996

Submitted in partial fulfillment of the  
requirements for the degree of

**MASTER OF SCIENCE IN ELECTRICAL ENGINEERING**

from the

**NAVAL POSTGRADUATE SCHOOL  
June 2003**

Author:

Steven J Perchalski

Approved by:

Xiaoping Yun  
Thesis Advisor

Fotis Papoulias  
Second Reader

John P Powers  
Chairman, Department of Electrical and Computer Engineering

THIS PAGE INTENTIONALLY LEFT BLANK

## **ABSTRACT**

This thesis studies the feasibility of developing a closed-loop shipboard sensor calibration system with two main objectives. The first objective was to reduce the number of personnel required to calibrate a shipboard sensor by 50%. The second was to reduce the time required to complete the calibration process by 60%. This was achieved by displaying the sensor data and the calibration standard data on a tablet PC. Wireless technology was used to transmit the data from the sensor and the calibration standard to the tablet PC. The data from the sensor is sent via IEEE 802.11b wireless LAN using DataSocket protocol and the calibration standard is sent via Bluetooth protocol. The technology can be installed and used on current ships in the United States Navy. Four software programs were developed to accomplish these goals. One program runs on the tablet PC and the other three run on the network capable application processor (NCAP). These four programs accomplish the goals stated.

THIS PAGE INTENTIONALLY LEFT BLANK

# TABLE OF CONTENTS

I.	INTRODUCTION.....	1
A.	REASON FOR NEW CALIBRATION TECHNOLOGY.....	1
B.	CURRENT PROCESS FOR CALIBRATION.....	1
C.	PROPOSED CONCEPT OF NEW TECHNOLOGY.....	2
D.	BENEFIT OF CONCEPT TO THE NAVY.....	3
E.	DESCRIPTION OF CHAPTERS IN THESIS.....	3
II.	PROBLEM STATEMENT AND PROPOSED APPROACHES.....	5
A.	PROBLEM STATEMENT.....	5
B.	PROPOSED APPROACHES.....	6
1.	Reduce Personnel Needed by 50%.....	6
2.	Reduce Time Required by 60%.....	7
C.	CONCLUSIONS.....	8
III.	HARDWARE DESCRIPTION AND DISCUSSION.....	9
A.	INTRODUCTION TO HARDWARE.....	9
B.	3ETI NETWORK CAPABLE APPLICATION PROCESSORS (NCAP).....	10
1.	Specifications of NCAP.....	10
2.	Operating Conditions.....	12
3.	Use in Thesis.....	13
C.	3ETI INDUSTRIAL GATEWAY.....	16
1.	Specifications.....	17
2.	Operating Conditions.....	17
3.	Use in Thesis.....	18
D.	PORTABLE PRESSURE CALIBRATOR.....	18
1.	Specifications.....	18
2.	Use in Thesis.....	19

E.	3eTI BLUETOOTH MODULE.....	22
	1. Specifications.....	22
	2. Concerns Over Bluetooth Technology in the Fleet.....	23
	3. Use in Thesis.....	23
F.	LAPTOP OR TABLET PC.....	24
	1. Specifications.....	24
	2. Use in Thesis.....	24
G.	OMEGA PRESSURE SENSORS.....	26
	1. Specifications.....	26
	2. Uses in Thesis.....	28
H.	HONEYWELL PRECISION PRESSURE TRANSDUCER.....	28
	1. Specifications.....	28
	2. Uses in Demonstration.....	29
I.	THE WIRELESS LAN.....	30
H.	CONCLUSION.....	31
IV.	SOFTWARE.....	33
A.	INTRODUCTION TO SOFTWARE.....	33
B.	WIRELESS_CAL_V2_1.EXE.....	33
	1. Role in Thesis.....	33
	2. Input and Output.....	34
	3. Flow of Data within the Program.....	34
C.	PERCHS_DAQ_LOCAL.EXE.....	38
	1. Role in Thesis.....	38
	2. Inputs and Outputs.....	38
	3. Operating Parameters.....	38
D.	UPDATE_READ_LOCAL_V2_3.EXE.....	40
	1. Role in Thesis.....	40
	2. Inputs and Outputs.....	40
	3. Operating Parameters.....	40
E.	HONEYWELL_SEND_DATA.EXE.....	42
	1. Role in thesis.....	42
	2. Inputs and Outputs.....	42
	3. Operating Parameters.....	42

F.	DATASOCKET TRANSFER PROTOCOL.....	43
G.	CONCLUSIONS.....	44
V.	RESULTS AND LESSONS LEARNED.....	45
A.	INTRODUCTION.....	45
B.	THE CONCEPT.....	45
C.	THE BEGINNING.....	45
D.	THE ADJUSTMENT PHASE.....	47
E.	THE FINISHING TOUCHES.....	49
F.	THE THIRTEENTH SHIP'S CONTROL SYSTEMS SYMPOSIUM 2003.....	52
G.	LESSONS LEARNED.....	54
	1. Timing is Important.....	54
	2. DataSocket Server Settings.....	54
	3. Bluetooth Loosing Connection.....	55
	4. LabVIEW Versions.....	55
	5. Reliability of the 3eTI NCAP.....	55
H.	CONCLUSIONS.....	56
VI.	CONCLUSIONS.....	57
A.	INTRODUCTION.....	57
B.	CONCLUSIONS.....	57
	1. Reduce Personnel Needed to do Closed-Loop Calibration.....	57
	2. Reduce the Time Required to do Closed-Loop Calibration.....	57
C.	FUTURE WORK.....	58
	1. Improving Software.....	58
	2. Displaying ICAS.....	59
	3. Providing a Reach Back Capability.....	59
APPENDIX A.	WIRELESS CAL V2_3 USER GUIDE.....	61
APPENDIX B.	PERCHS_DAQ1_LOCAL.EXE.....	69

APPENDIX C.	UPDATE_READ_LOCAL_V2_3.EXE.....	73
APPENDIX D.	HONEYWELL_SEND_DATA_V1_3.EXE.....	77
LIST OF REFERENCES.....		81
INITIAL DISTRIBUTION LIST.....		83

## LIST OF FIGURES

1.	Diagram Showing Use of Wireless NCAP and Gateway in Shipboard Environment Such as DDG 83.....	5
2.	Proposed Look for the Laptop/Tablet PC.....	6
3.	Concept of Information Flow.....	7
4.	The Simulated Shipboard Environment.....	9
5.	ICP Daughter Boards Used in the NCAP.....	11
6.	The Interior of the NCAP.....	12
7.	NCAP Interior.....	13
8.	NCAP Exterior.....	14
9.	NCAP Bottom.....	15
10.	Connecting the Sensor to the NCAP.....	15
11.	Top of the 3e-521N Gateway.....	16
12.	The 3eTI Gateway Exterior.....	17
13.	The Crystal XP <sup>2</sup> Digital Test Gauge and Handheld Pump with Bluetooth Adaptor Installed on the Back of the PPC.....	19
14.	Dimensions of Crystal PPC.....	20
15.	Front of Crystal Digital Test Gauge.....	21
16.	Back of Crystal Digital Test Gauge.....	21
17.	The 3e-250 Bluetooth to RS-232 Cordless Adapter.....	22
18.	D-LINK DBT-120 USB Bluetooth Adapter.....	25
19.	TOSHIBA Protégé 3500.....	25
20.	BELKIN Bluetooth F8T002 PCMCIA Bluetooth Card.....	26
21.	The PX205 4-20 mA Pressure Transducer Series.....	27
22.	The Honeywell PPT.....	30
23.	The LabVIEW Diagram of Wireless_cal_v2_2.exe.....	35
24.	The Diagram of Perchs_daql_local.exe.....	39
25.	The Diagram of Update_read_local_v2_3.exe.....	41
26.	The Diagram of Honeywell_send_data_v1_3.exe.....	43
27.	The Display of the Cont Acq&Chart (Easy Immed).vi Program.....	47
28.	The Comparision_code_ds.vi Display.....	50
29.	The Wireless_cal_v2_1.vi Display.....	52

THIS PAGE INTENTIONALLY LEFT BLANK

## LIST OF ABBREVIATIONS

HM&E	Hull, Mechanical and Electrical
MCS	Machinery Control Systems
VI	Virtual Instrument
NCAP	Network Capable Application Processor
PPC	Portable Pressure Calibrator
SCSS	Thirteenth International Ship Control Systems Symposium
W-LION	Wireless Input/Output Node
ICP	A registered trademark of PCB Group, Inc.
ICAS	Integrated Condition Assessment System
DHCP	Dynamic Host Configuration Protocol
IrDA	Infrared technology transmitter and receiver
HMI	Human Machine Interface
NPS	Naval Postgraduate School
CBM	Condition Based Maintenance
RCM	Reliability Centered Maintenance
NEMIAS	Navy Enterprise Maintenance Automated Information System
ERP	Enterprise Resource Planning
ISIC	Immediate Superior In Charge
DS	DataSocket
SubVI	Subsidiary Virtual Instrument
PPT	Precise Pressure Transducer

THIS PAGE INTENTIONALLY LEFT BLANK

## **ACKNOWLEDGMENT**

The author would like to acknowledge the financial support of Corona Division, Naval Surface Warfare Center, for allowing the purchase of equipment used in this thesis, and to thank the following people for technical and moral support during the course of this thesis effort: Jeff Walden, Randy Rupnow, Hal Glick, and Steve Glicklick of NSWC-Corona, and Dan Greaves of 3eTI.

The author would like to specially appreciate Mark McLean of Naval Sea Systems Command and Professor Fotis Papoulias for providing funding and mentoring to attend the Thirteenth International Ship Control Systems Symposium in Orlando, FL from 7 to 9 April 2003. That experience will forever help my career and it fostered a love of community and the people working to better the community that could not have been found anywhere else.

The author would finally like to thank Professor Xiaoping Yun for all his guidance during this thesis. His patience and understanding was unmatched during the entire time. Thank you sir for your time and the great topics you research.

THIS PAGE INTENTIONALLY LEFT BLANK

## **EXECUTIVE SUMMARY**

This thesis presents an application of wireless technology in a shipboard environment. The application is on developing a closed-loop shipboard sensor calibration system with two main objectives. The first objective is to reduce the personnel required to conduct a sensor calibration. The second objective is to reduce the time required to complete the calibration process. This is accomplished using wireless protocols and using technology that can be easily installed or used on United States Navy ships.

Using the DataSocket protocol, this thesis proves that pressure data that is wirelessly transmitted via IEEE 802.11b from a Network Capable Application Processor (NCAP) or Wireless LAN Input Output Node (W-LION) to an access point or gateway can be displayed on a wireless tablet computer. At the same time, the calibration standard being applied to the system is transmitted via Bluetooth to the wireless tablet computer. Both pressures are displayed simultaneously on the screen while the computer computes the difference and compares the sensor data versus an operator entered tolerance. A green light indicates that the difference is within tolerance and a red light indicates that the difference is not within tolerance. The operator can then adjust the calibration constants on the tablet computer screen and watch the sensor data come within tolerance. Once the sensor data is within tolerance, the operator can write the constants wirelessly to the NCAP. This process reduces the number of personnel required to calibrate a sensor from two to one, and the time required by a factor of ten. It also helps the Navy facilitate condition based maintenance assisting the United States Navy to move forward with initiatives that reduce manning and streamline processes.

THIS PAGE INTENTIONALLY LEFT BLANK

# **I. INTRODUCTION**

## **A. REASON FOR NEW CALIBRATION TECHNOLOGY**

Currently on DDG ships there are 3,742 hull, mechanical and engineering (HM&E) sensors. They take readings such as temperature, pressure, or flow rate. Over seventy percent (2,669) require periodic calibration. Forty-five percent (1,189) of those that require calibration have standard visual gauge type displays. The other fifty-five percent (1,480) of those that require periodic calibration send data for display on the ship Machinery Control Systems (MCS) displays. [Ref. 2 p.1 to 2] Some examples of these sensors are 0 to 5 volt and 4 to 20 milliamp pressure sensors. Calibration constants are used to convert the output voltage or current to a pressure. With the United States Navy moving towards lower manning levels, more sensors will be required to monitor equipment. As the number of sensors increases and the number of people available to maintain these sensors falls, new technology will be required to streamline the maintenance and upkeep of these sensors. The accuracy of these sensors will be critical in a reduced manning environment. Calibration will need to become easier and faster in order to keep up with the future of the U.S. Navy.

## **B. CURRENT PROCESS FOR CALIBRATION**

The current process to calibrate these remote display sensors is labor intensive and requires two or more service members to complete the task. This thesis uses existing wireless technology to reduce the personnel required and the time spent in the calibration process. Here is what comprises the current process. A team of technicians from a shore command (SISCAL) comes on board to calibrate the required sensors. They bring with them “portable” equipment that has a total weight of over 100 pounds and includes clumsy tanks and large boxes. [Ref. 2] Ship’s force tags out the equipment from service and the SISCAL team then closes the sensor isolation valves isolating the sensor from the system. The calibration standard is physically connected to the sensor and the standard is

applied to the sensor. Since the display for these sensors is typically located in another space on the ship, a second or third operator is required to read what the sensor is outputting for display. The operators are communicating via radio or cell phone. Multiple data points are taken. One of the operators writes down the two values, the value from the remote indicator and the value from the standard, at each data point and then calculates whether the difference between the sensor and the standard is within tolerance. If the sensor is within tolerance, the team moves on to the next sensor. If the sensor is not within tolerance, new calibration constants are calculated by hand using a linear model of the voltage-to-pressure equation. Then the calibration constants are changed on a signal conditioning card located between the sensor and the display by adjusting a potentiometer. Once the calibration constants have been changed, the process starts all over again. The operators verify that the new constants are set correctly and that the sensor is outputting a pressure now within tolerance.

### **C. PROPOSED CONCEPT OF NEW TECHNOLOGY**

This thesis uses current wireless technology to display on a laptop PC, tablet PC or PDA both the value from the sensor and the value from the standard. The computer then compares the two signals and determines whether the difference is within tolerance. It has an easy to read display that shows in real time the two values and a green light when the sensor is within tolerance and a red light when the sensor is out of tolerance. If the sensor is out of tolerance, the operator can adjust the on screen calibration constants and watch for when the sensor reads within tolerance. Once the operator has made the proper adjustments to the calibration constants, the constants are sent wirelessly to the signal conditioner and written to the card. The calibration process for that sensor is complete. This process required only one operator, since the display is on one screen, and can be completed in less than half the time required to currently calibrate sensors.

#### **D. BENEFIT OF CONCEPT TO THE NAVY**

The thesis has the possibility of positively plausible benefits to the maintenance of U.S. Navy ships. By streamlining the calibration process, we have reduced the number of operators needed and the time required to calibrate a single sensor. This also makes the process of calibration easier leading to the possibility that calibration of embedded sensors may be possibly passed onto ship's force. This follows what Admiral Vern Clark, USN talks about in his Sea Basing portion of Sea Power 21. "This means transforming shore-based capabilities to sea-based systems whenever practical..." [Ref. 1] As the Navy experiments with optimum manning initiatives to reduce crew size while increasing sustainability, this technology makes sense for the transformation of the Navy to a world of fewer operators, more condition based maintenance and a more precise automated environment. This thesis also demonstrates the potential for the use of "smart sensors" which have the calibration constants imbedded in the sensor and no longer need a signal conditioner to display the data.

#### **E. DESCRIPTION OF CHAPTERS IN THESIS**

This first chapter is the introduction to the thesis. The second chapter covers the problem statement and proposed approaches to the thesis. The third chapter concentrates on the hardware components of the thesis. It discusses each component's specifications, operating conditions, and use in thesis. The fourth chapter examines the software designed in the thesis. Each code has its own section to discuss the role in the thesis, the inputs and outputs and the how it works. The "how it works" section analyzes each additional code that may be found within the main code being discussed. The fifth chapter presents the results that were found and discusses what worked and what failed. The sixth chapter has the conclusions from the thesis. This includes what was accomplished by this thesis and any future work that may be needed. The appendices contain the Virtual Instruments (VI) that were designed and used for this thesis and a user's manual for each VI.

THIS PAGE INTENTIONALLY LEFT BLANK

## II. PROBLEM STATEMENT AND PROPOSED APPROACHES

### A. PROBLEM STATEMENT

As shown in the introduction, there is a need for a new process to calibrate sensors. The plan was to develop a new process that **reduces personnel** needed to do closed-loop calibration, and **reduces the time required** to do the calibration. The goal was to reduce the personnel by 50% and the time required by 60%.

The goals were to be achieved while following these constraints: the use of current wireless technology, which needs to be implemented in the next five to ten years and can be easily added to new ship construction and could be retro-fitted onto older ships. Wireless technology is slated to be installed and used on United States Navy ships. Figure 1 shows how the wireless environment works on a ship. USS HOWARD DDG 83 had 40 wireless Network Capable Application Processors (NCAPs) installed for at-sea testing in January of 2002. [Ref. 1] USS MASON DDG 87 is slated to be built with the wireless NCAPs and Gateways used in this thesis. [Ref. 10] The technology used in this thesis is in the fleet and shows a good application of a wireless ship environment.

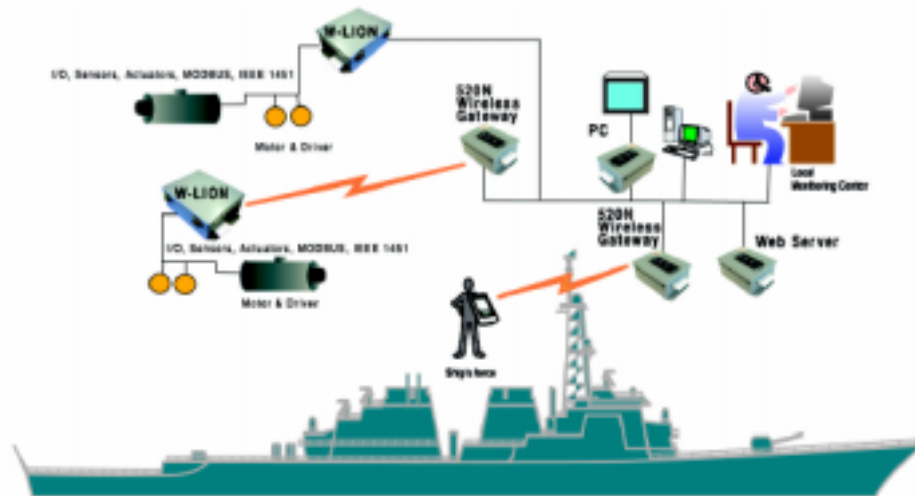

Figure 1. Diagram Showing Use of Wireless NCAP and Gateway in Shipboard Environment Such as DDG 83. [From Ref. 3 p.i.]

## B. PROPOSED APPROACHES

### 1. Reduce Personnel Needed by 50%

The proposed material reduces the personnel needed from two or more to one by displaying the sensor data and the calibration standard together on one screen. Figure 2 shows the developed display. This removes the need to have an additional person needed to read the data from the remote display. The process uses wireless technology to achieve the simultaneous data display. By wirelessly sending sensor data to the ship's LAN, the signal can then be retrieved by a wireless laptop/tablet PC and displayed next to the data from the calibration standard. Figure 3 shows the wireless information flow implemented in this thesis. Since the laptop/tablet PC is portable and can be located close to the sensor being calibrated, it leads to the use of Bluetooth technology to transmit the standard value to the laptop/tablet PC.

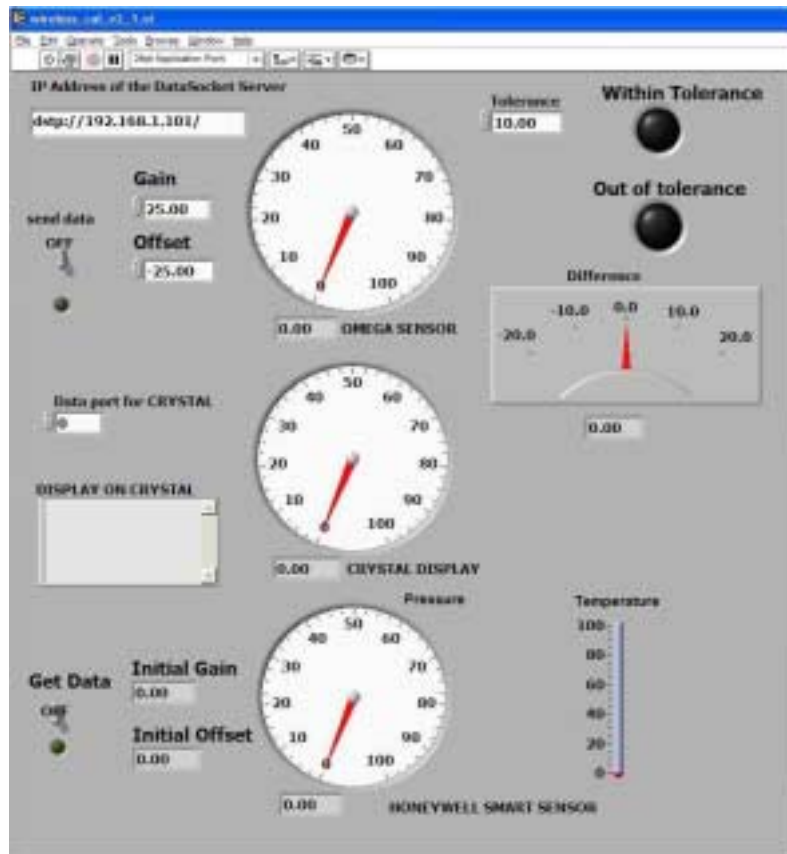

Figure 2. Display and Interface on the Laptop/Tablet PC.

## 2. Reduce Time Required by 60%

To achieve the goal of reducing time required, the plan is to make it easier to take measurements and easier to change the calibration constants. To make it easier to take measurements the sensor data is seen and changed in real time. The raw wireless data is converted by the laptop/tablet PC to a pressure using calibration constants that are changeable and displayed on the screen. A user is able to take three to four measurements and do the math in the same time that was needed to take the measurements. The tolerance calculation is computed by the computer instantly and displayed. This eliminates one step that the operator has to do. Since the calibration constants would be written on software contained within the NCAP or signal conditioner, the process of writing the calibration constants to the signal conditioner has become more accurate and faster. Using wireless technology, the calibration constants can be sent from the laptop/tablet PC to the NCAP by a click of a button. The user no longer needs to pull a signal conditioner card and turn a potentiometer.

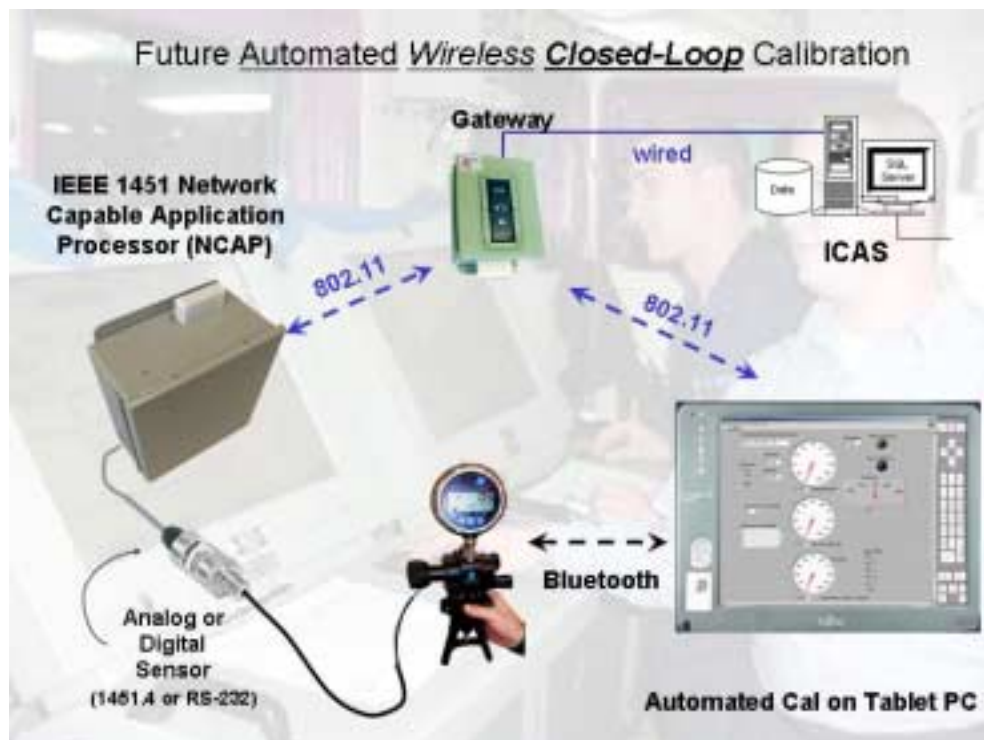

Figure 3. Concept of Information Flow.

## **C. CONCLUSIONS**

In summary the research problem was to reduce the personnel required to complete a closed-loop calibration and to reduce the time required to do such calibration. These were accomplished by using current wireless technology and can be ready in the next five to ten years. By displaying the data from the sensor next to that of a standard and then comparing the two readings, the process for calibration has been changed to accomplish these goals. In order to prove and test the theory, a simulated shipboard environment was set up in the lab. The research focuses on pressure sensors because the portable pressure calibrator (PPC) could be used and tested. The next chapter examines the hardware that was used to during the thesis.

### III. HARDWARE DESCRIPTION AND DISCUSSION

#### A. INTRODUCTION TO HARDWARE

This chapter discusses the different types of hardware used in this thesis. The equipment used includes the 3eTI NCAP, the 3eTI Gateway, Crystal XP<sup>2</sup> Digital Test Gauge (PPC), 3eTI Bluetooth adapter, laptop PC/tablet PC, Omega pressure sensor, Honeywell “smart sensor” and the wireless LAN. Figure 4 shows the working display used to demonstrate the technology at the Thirteenth International Ship Control Systems Symposium 2003 in Orlando, FL from 7 to 9 April 2003.



Figure 4. The Simulated Shipboard Environment. Display used at the Thirteenth International Ship Control Systems Symposium (SCSS) in Orlando, FL., from 7 to 9 April 2003.

## **B. 3ETI NETWORK CAPABLE APPLICATION PROCESSORS (NCAP)**

The 3eti NCAP is the workhorse of this project. It is also known as 3e-550I Industrial Wireless Input/Output Node (W-LION). The NCAP is a case-hardened data acquisition processor that meets shock, water-tight, and other military requirements for installation onboard United States Navy ships. It is also equipped with 802.11b wireless LAN capabilities. It is basically a case-hardened computer that connects to the sensors and then transmits the sensor data via 802.11b protocol.

### **1. Specifications of NCAP**

Dimensions and weight of the NCAP are 11.5" x 8.9" x 5" and 10 lbs, 9 ounces. Some of the features of the NCAP are:

- Pentium type processor.
- 256 Mbytes RAM and 256 Mbytes Flash Memory.
- National Instruments 6034e Data Acquisition Card 200 kilosamples per second (ksps).
- 8 analog inputs (16 bits, 200 ksps aggregated)
- 8 daughter board slots to customize input from sensor.
- LAN TCP/IP protocols.
- Serial RS-232 capability.
- Embedded Microsoft Windows XP operating system.
- Embedded National Instruments LabVIEW 6i for data acquisition and data analysis.

The NCAP uses ICP (ICP is a registered trademark of PCB Group, Inc.) daughter boards or personality modules to interface with the sensors. [Ref. 4] Each different type of sensor requires a specific type of daughter board. Figure 5 shows the daughter boards used in the NCAP. Figure 6 shows how the daughter boards are installed. The NCAP

has eight slots for the daughter boards, and the daughter boards easily slip into the slots and then secure via a small screw. Daughter boards are available for 4 to 20 mA, 0 to 5 V, 0 to 10 V,  $\pm 5$  V,  $\pm 10$  V, all common temperature sensors, vibration sensors, proximity sensors, flow meters, pressure sensors, speed sensor, and contact closure.



Figure 5. ICP Daughter Boards Used in the NCAP. Top and bottom boards are for a 0 to 5 volt pressure sensor. The middle is for a 4 to 20 mA pressure sensor.



Figure 6. NCAP Interior. This shows an ICP daughter board being installed.  
[From Ref. 4.]

## 2. Operating Conditions

The NCAP runs a data acquisition and managing program that acquires data, signal processes the raw data and the sends the data to the ship's W-LAN. This program comes with the NCAP and runs continuously to send data to the Integrated Condition Assessment System (ICAS) or the ship's LAN. The best way to think of the NCAP is to think of it as a Desktop PC. It even has hook-ups for a keyboard, mouse and monitor located on the mother board as seen in Figure 7. It uses a Microsoft Windows XP operating system. The processor is a Pentium type, which is very capable for the job.



Figure 7. The Interior of the NCAP. The serial port, keyboard, monitor, and mouse inputs can be seen near the bottom of the case.

### 3. Use in Thesis

The NCAP is connected wirelessly to the tablet PC via the 3eTI Gateway. It can also be wired via a standard Ethernet hub to a laptop or tablet computer if this is needed. There is a program on the NCAP called `vncviewer.exe`. This program enables a computer connected either through Ethernet cable or wirelessly to view and control the desk-top of the NCAP. This program is used to start and change programs that are running on the NCAP. The NCAP is physically attached to the sensor. Figures 8, 9 and 10 show the outside of the NCAP, with Figure 9 displaying the input and output connections. Three programs designed for this thesis are installed on the NCAP. They can either be running all the time or can be started using the `vncviewer.exe` program. All the operator would need is the IP address of the NCAP and the password to access the

NCAP. The programs function as data acquisition programs that extract the data from the sensors and transmit it to the tablet PC prior to being conditioned by the NCAP. These programs are discussed in the next chapter. Sending the data before it is conditioned, allows the wireless cal program, located on the tablet PC, to do the signal conditioning.



Figure 8. NCAP Exterior. [From Ref. 4.]



Figure 9. NCAP Bottom. [From Ref. 4.]



Figure 10. Connecting the Sensor to the NCAP. [From Ref. 4.]

### C. 3ETI INDUSTRIAL GATEWAY

The 3eTI Gateway is officially known as 3e-521N wireless dual mode gateway. It is a hardened 802.11b access point that meets military standards for installation onboard United Navy ships. The 3eTI Gateway is the access point to the ship's LAN. It allows the NCAP and the tablet PC access the ship's LAN to send and receive data to and from the LAN. Figures 11 and 12 show the outside of the industrial Gateway.

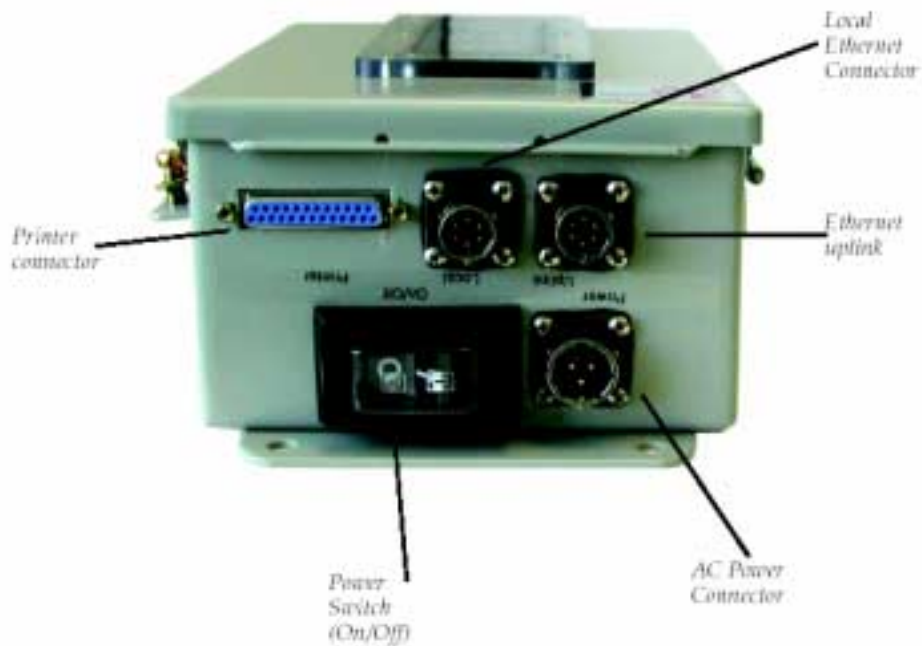

Figure 11. Top of the 3e-521N Gateway. [From Ref. 5.]



Figure 12. The 3eTI Gateway Exterior. [From Ref. 5.]

## 1. Specifications

The 3eTI Industrial Gateway or 3e-521N wireless gateway, key features include:

- Operates in gateway or access point mode.
- The processor is based on the x86 processor.
- PCI bus architecture.
- H.323 IP (Netmeeting, VoIP) support.
- Integrated wireless print server.
- RJ-45 10/100 Mbps IEEE 802.3 LAN connection (Ethernet uplink)

The dimensions and weight of the Gateway are 6.25" x 6" x 3.75" and 10 lbs. [Ref. 5]

## 2. Operating Conditions

The 3eTI Gateway has two operating modes, access point mode and gateway mode. In the access point mode the 3eTI Gateway lets the network assign the IP address. Another way to say this is that it acts as a Dynamic Host Configuration Protocol (DHCP) pass through. This allows the network to assign IP addresses. In the gateway mode, the

3eTI Gateway acts as a DHCP server and, since the 3eTI Gateway is the back bone of the network, it offers a little more security via firewall capabilities. It uses a COTS 802.11b (WI-FI) card and Infrared technology (IrDA) to communicate with clients. [Ref. 5] The 802.11b protocol offers 11 Mbps with a fall back to 5.5, 2 and 1 Mbps depending on signal strength. The IrDA can be used to link with local (less then 1 meter) PDAs or tablet PCs. The IrDA is line of sight medium and must have an unobstructed path to and from the 3eTI Gateway and PDA.

### **3. Use in Thesis**

In this thesis the 3eTI Gateway was used in the access point mode. On board a ship the 3eTI Gateway would be physically connected to the Ship's LAN. This is simulated with a LINKSYS standard Ethernet hub. The LINKSYS Ethernet hub acts as the DHCP server and assigns IP addresses to all hardware. The 3eTI is wirelessly connected to the NCAP and the tablet PC. The 3eTI Gateway has the ability to connect locally to the tablet PC through a standard Ethernet hub. The 3eTI Gateway has the ability to connect to multiple NCAPs at the same time.

## **D. PORTABLE PRESSURE CALIBRATOR**

The portable pressure calibrator (PPC) used is made by Crystal Engineering Corporation. The XP<sup>2</sup> Digital Test Gauge is the name of the model used in this thesis. The testing range of the calibrator is 100 psi. The PPC is an extremely accurate pressure sensor that is used to verify whether or not the sensor is operating properly. This is often referred to as the calibration standard.

### **1. Specifications**

It has an accuracy of 0.1% of the reading. It is fully temperature resistant which means it can be used in the hottest of main engine rooms without affecting the accuracy.

It is powered buy 3 AA batteries and has an operating life of 1500 hours. It has a standard RS-232 serial port located on the back. [Ref. 6]

## 2. Use in Thesis

The digital test gauge is used as the standard in this thesis. It is wirelessly connected to the laptop/tablet PC via a Bluetooth serial port adaptor. Figure 13 shows the PPC with Bluetooth adaptor attached to the back. The pressure is provided by a handheld pump that can use either pneumatic or hydraulic mediums. The pump is not discussed in a separate section but is discussed briefly here in this section since the PPC and the pump go together as one unit. The maximum pressures that the pump can produce are 600 psi for pneumatic or 10,000 psi for hydraulic. [Ref. 6] The pump is lightweight and has a small footprint, making it easy to store and transport. Figure 14 shows the dimensions of the digital test gauge. Figures 15 and 16 show the front and back of the digital test gauge.



Figure 13. The Crystal XP<sup>2</sup> Digital Test Gauge and Handheld Pump with Bluetooth Adaptor Installed on the Back of the PPC.

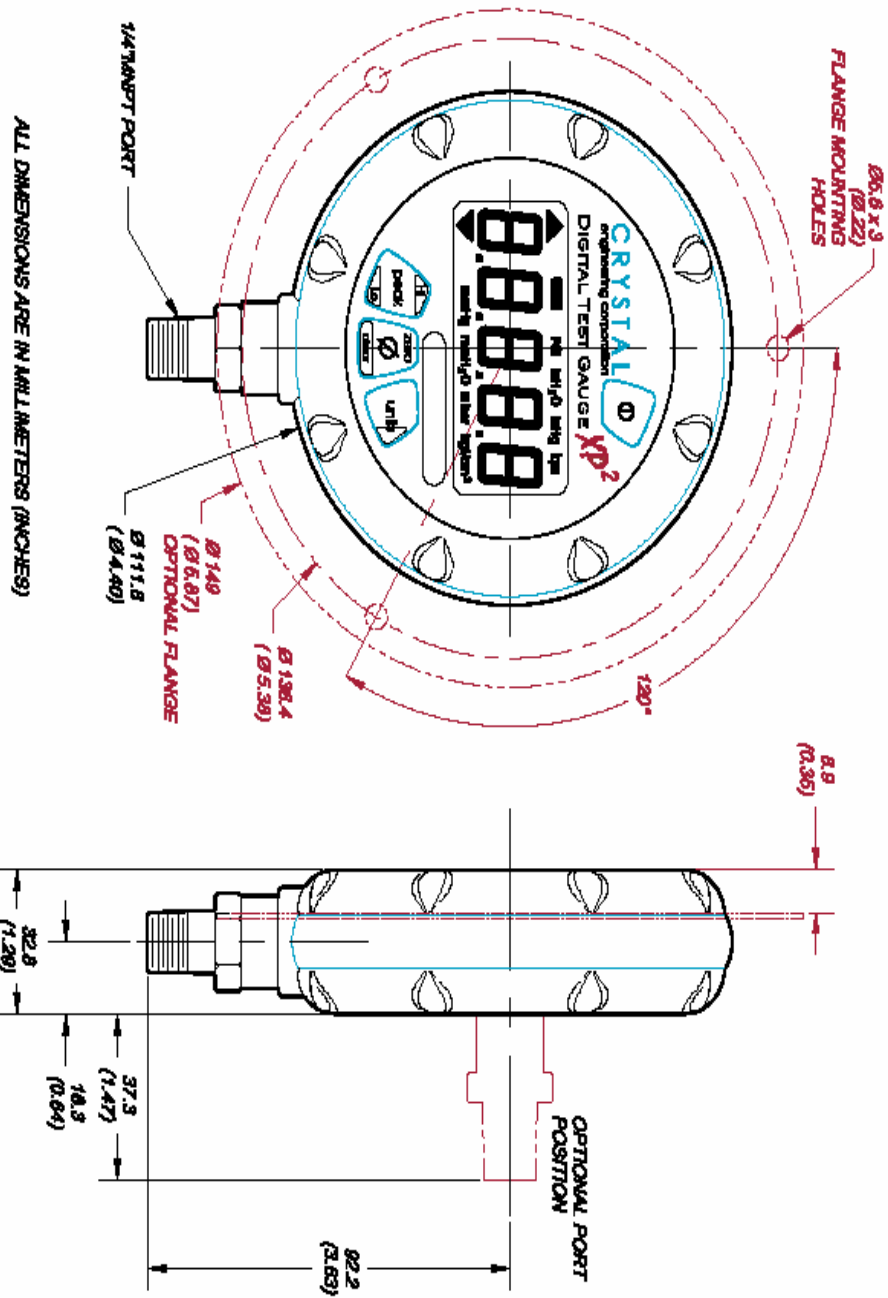

Figure 14. Dimensions of Crystal PPC. [From Ref. 7.]



Figure 15. Front of Crystal Digital Test Gauge. [From Ref. 7.]



Figure 16. Back of Crystal Digital Test Gauge. [From Ref. 7.]

## E. 3eTI BLUETOOTH MODULE

The 3e Technologies International 3e-250 Bluetooth to RS-232 cordless adapter is a small portable serial port to Bluetooth converter as shown in Figure 17. It converts the data flow from an RS-232 serial port connection to Bluetooth protocol and transmits to other Bluetooth adapters. This module is used to eliminate the need for a wire connecting the PPC and the tablet PC. The module is connected and mounted to the back of the Crystal digital test gauge.



Figure 17. The 3e-250 Bluetooth to RS-232 Cordless Adapter. [From Ref. 6.]

### 1. Specifications

Some of the features of the Bluetooth adapter are:

- True plug and play capability. No driver software required.
- 30 meter/100 feet range.
- Bluetooth 1.1 specification compliant transceiver with 4dBm of transmit power as a class 2 or 3 device.
- Shared data rate of 732 Kbps

## **2. Concerns Over Bluetooth Technology in the Fleet**

Although Bluetooth protocols have not been approved for shipboard use, we decided to continue with this protocol to show the ease and possible use of this technology. Bluetooth and 802.11b use the same frequency of 2.4 GHz. The range of the Bluetooth is much less than that of the 802.11b. For that reason, the Bluetooth protocol does not have the same security features that the 802.11b protocol has. It is my belief that because of the short range of the Bluetooth protocol, the lack of security features should not be a reason to not approve the protocol for shipboard use. A concern is that someone might be able to hack into the system using the Bluetooth connection. Since the Bluetooth only connects the Standard and the laptop/tablet PC and these systems are only connected to the LAN during calibration procedures, the likelihood of a hacker knowing the time when calibration is being done and then using the limited time that the calibration process takes place to hack into the system is very a small chance. The hacker must also be very close if not within the same space that the calibration is taking place since the range of the Bluetooth adaptor is about 30 meters. So we used Bluetooth to demonstrate the capability of the protocol and the ease of use.

## **3. Use in Thesis**

This Bluetooth adaptor is physically attached to the back of the Crystal digital test gauge. It is connected via a null serial cable. It is then connected wirelessly to the tablet PC. The adaptor is used to transmit wirelessly the calibration standard from the system to the laptop/tablet PC.

## **F. LAPTOP OR TABLET PC**

In this thesis the laptop and tablet PC serve the same function and are discussed here in the same section. The laptop/tablet PC acts as the user interface to the entire process. It contains the wireless calibration software enabling the operating to calibrate the sensor wirelessly. It also contains the vncviewer.exe which is a program that enables an operator on one PC view and control the desktop of another PC.

### **1. Specifications**

The laptop used was a DELL Inspiron 8200 1.6 GHz computer with Microsoft Windows XP Professional operating system. It had an embedded 802.11b card, and we used a DBT-120 USB Bluetooth adapter by D-LINK shown in Figure 18. The tablet computer used was a TOSHIBA Protégé 3500 series tablet computer 1.33 GHz computer with Microsoft Windows XP tablet. The tablet used a Belkin p/n F8T002 PCMCIA Bluetooth card. Figures 19 and 20 show the tablet computer and the Bluetooth PCMCIA card.

### **2. Use in Thesis**

Both systems were used as a platform to run the wireless\_cal program which receives data from the sensor wirelessly and then processes the data for the operator. This is the main human machine interface (HMI) of the process. It provides the user with the data display needed to do the calibration. The laptop/tablet PC was also used to run the vncviewer.exe program and operate the NCAP remotely.

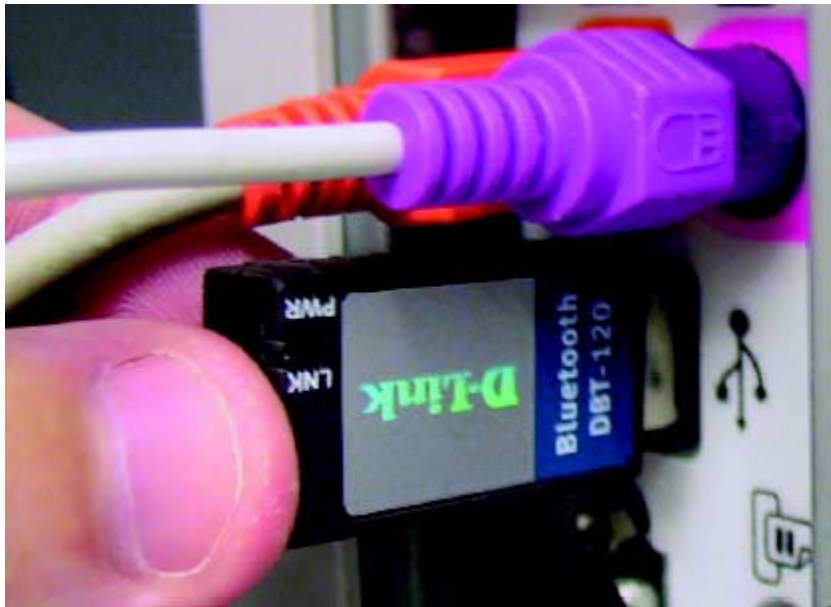

Figure 18. D-LINK DBT-120 USB Bluetooth Adapter. [From Ref. 10.]

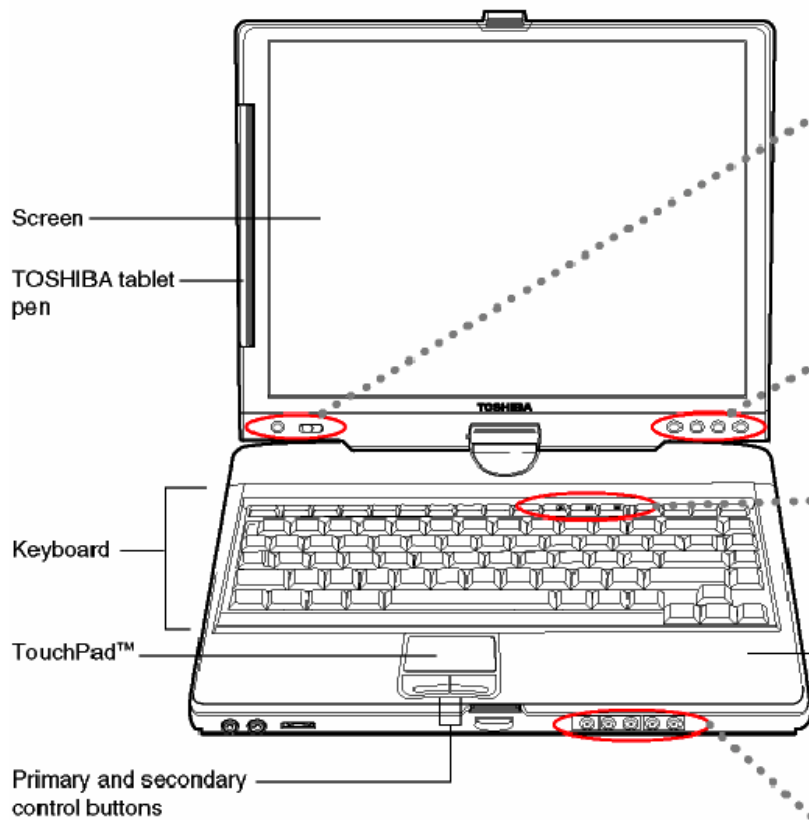

Figure 19. TOSHIBA Protégé 3500. [From Ref. 8.]



Figure 20. BELKIN Bluetooth F8T002 PCMCIA Bluetooth Card. [From Ref. 13.]

## **G. OMEGA PRESSURE SENSORS**

Two separate types of pressure sensors were used. They were PX203 0.5 to 5.5 Vdc and PX205 4 to 20 mA pressure transducers. We primarily used the PX205 version because it was easier to wire to the NCAP. Figure 21 shows the family of sensors from Omega.

### **1. Specifications**

The Omega PX203 and PX205 pressure transducer have the following common specifications. [Ref. 14]

- Accuracy: 0.25 %
- Zero Balance: 1 %FS
- Compensated temp:  $-4^{\circ}$  to  $176^{\circ}\text{F}$
- Thermal effects: 1.5 %FS over  $-4^{\circ}$  to  $176^{\circ}\text{F}$
- Response Time: 1 msec
- Gage Type: Chemical vapor deposited polysilicon strain gages reverse polarity protected.
- Electrical: Miniature DIN connection.

- Weight: 3.5 ounces

Specifications solely for the PX203 voltage input series follow. [Ref. 14]

- Excitation: 24 Vdc @ 15mA (7 to 35 Vdc)
- Output: 0.5 to 5.5 Vdc
- Span: 5 Vdc  $\pm$  50 mV
- Operating Temperature:  $-40^{\circ}$  to  $257^{\circ}$ F
- Output resistance: 100  $\Omega$

Specifications solely for the PX205 current output series follow. [Ref. 14]

- Excitation: 24 Vdc (7 to 35 Vdc) reverse polarity protected
- Output: 4 to 20 mA (2-wire)
- Operating temperature:  $-40^{\circ}$  to  $257^{\circ}$ F
- Span Tolerance: 1 %FS
- Maximum loop Resistance: 50 X (supply voltage  $-7$ )  $\Omega$



Figure 21. The PX205 4 to 20 mA Pressure Transducer Series. The transducer on the top with the wire attached is the model used in this thesis. The PX203 looks very similar but is shorter in length. [From Ref. 15.]

## **2. Uses in Thesis**

These transducers were used as the sensor that needed calibration. We implemented the pressure to these sensors using the PPC/Pump team. The sensor sends a voltage or current to the NCAP. The ICP daughter boards receive the signal and either pass it on or convert it to a voltage. The data acquisition card in the NCAP only receives a voltage, so the daughter boards convert all the analog signals into a voltage. The voltage is then converted to a digital signal and sent to the laptop/tablet PC for calibration using the code that was developed for this thesis.

## **H. HONEYWELL PRECISION PRESSURE TRANSDUCER**

This thesis does not use the Honeywell precision pressure transducer (PPT) as a source for the pressure. It was used in the demonstration at the SCSS 2003 in Orlando, FL because we wanted to show where the technology is heading. The precision pressure transducer is different from a regular transducer because the output from the transducer is a digital signal through an RS-232 port and not an analog voltage or current. The calibration constants are located within the transducer and no longer need to be located in a signal conditioner.

### **1. Specifications**

The part number of the pressure transducer is PPT0100AWN2VA-A. The following specifications apply. [Ref. 9]

- Accuracy: (from  $-40^{\circ}$  to  $185^{\circ}$  F)
  - Digital:  $\pm 0.05$  % FS Typical.,  $\pm 0.10$  % FS Maximum
  - Analog:  $\pm 0.06$  % FS Typical.,  $\pm 0.12$  % FS Maximum
  - Temperature:  $\pm 1^{\circ}$ C (at sensing element)

- Temperature Range:
  - Operating:  $-40^{\circ}$  to  $185^{\circ}\text{F}$
  - Storage:  $-67^{\circ}$  to  $194^{\circ}\text{F}$
- Sample rate: 8.33 ms to 51.2 min
- Resolution:
  - Digital: Up to 0.0011 % FS
  - Analog: 1.22 mV Steps (12 bits)
- Response Delay: +1 ms, maximum 17 ms
- Long term stability: 0.02 % FS max per yr.
- Suitable for non-condensing, non-corrosive, and non-combustible gases.
- Weight 5 oz. without fittings.
- Output: RS-232 Digital with 0 to 5 V analog.
- Output: RS-485 Digital with 0 to 5 V analog.
- Supply Voltage: 5.5 to 30 Vdc.
- Operating current: 17 to 30 mA
- Baud rate: 1200, 2400, 4800, 9600, 14400, 19200, 28800.

## **2. Uses in Demonstration**

The Honeywell PPT, as shown in Figure 22, was used to demonstrate how a PPT connects with the NCAP and the ease of use of the PPT. On the wireless calibration program, the bottom of the screen contains the pressure and temperature that the PPT transmits. This can be used to show that a PPT can be used with the program. As seen, from the specifications, the PPT is more accurate than the standard that we use in this thesis. So a calibration cannot be done on the PPT with the PPC. In a regular analog sensor, the calibration constants must be set after installation. The convenience of the PPT allows a user to calibrate the sensor in a lab and then install the sensor and not have

to set the calibration constants, because they have already been set. Instead of calibrating the sensor it can be swapped with a sensor known to be within tolerance and then calibrated in a lab. This plug and play ability allows for more accurate sensors with less maintenance. A future advancement would be to include a wireless transmitter with the transducer and by-pass the NCAP all together.



Figure 22. The Honeywell PPT. [From Ref. 9.]

## I. THE WIRELESS LAN

The wireless LAN used in this thesis is comprised of a standard LINKSYS Ethernet Hub wired to the 3eTI Gateway, which is then wirelessly connected to the 3eTI NCAP and the laptop/tablet PC. The LINKSYS hub acts as the DHCP server and simulates a ship's LAN. All components use a standard COTS 802.11b card. A separate wireless link is set up between the Calibration standard and the laptop/tablet PC using Bluetooth-to-serial port adaptors. These are both COTS components that have the ability

to use a 128-bit encryption code for security. For ease of the demonstration the encryption was not used. The encryption does not provide as much security as the 802.11b standard provides, but it is a small level of security.

## **H. CONCLUSION**

In this chapter all the components that were used in the simulated ship environment were described. The equipment included the NCAP, Gateway, Bluetooth-to-RS-232 adaptor, PPC, laptop/tablet PC, pressure sensors and the PPT. We now know how each component fits into the puzzle and what the function of each piece is. The next chapter discusses the software that these components use to make the process happen. It discusses the function in the thesis, the input and output, and the flow of information internal to the code.

THIS PAGE INTENTIONALLY LEFT BLANK

## **IV. SOFTWARE**

### **A. INTRODUCTION TO SOFTWARE**

This thesis uses four newly developed programs for data acquisition and processing. The four programs were developed using the LabVIEW language and compiler. The names of the four programs are `wireless_cal_v2_1.exe`, `perchs_daq_local.exe`, `update_read_local_v2_2.exe`, and `Honeywell_send_data_v1_3.exe`. They are explained in detail later in the chapter, and they are also shown in the Appendices (along with a user's guide for each code).

### **B. WIRELESS\_CAL\_V2\_1.EXE**

This program is the main program for the wireless calibration process. It is the primary HMI for the wireless closed-loop calibration, and runs on the laptop/tablet PC.

#### **1. Role in Thesis**

The purpose of this program is to display both the calibration standard and the sensor data side by side. It automatically calculates the difference between the two and then determines if the difference is within a user-defined tolerance. The program then displays a red light if the difference is not within tolerance or a green light if the difference is within tolerance. If the sensor is out of tolerance, the operator can change the calibration constants by touching the up or down arrow next to the constant that needs to be changed and watch the difference move to be within tolerance. Once the sensor is within tolerance, the calibration constants used to get the sensor within tolerance are sent wirelessly to the NCAP by the click of a button. When the operator starts the calibration process, he or she can click a button and receive the current values for the sensor they are going to calibrate. These values must then be entered into the gain and offset blocks on the top of the screen before the calibration can start.

## **2. Input and Output**

The program takes in data from three programs. It receives a voltage reading from the sensor via the `perchs_daq_local.exe` program. The data display from the calibration standard. The pressure and temperature output from the Honeywell PPT using the `Honeywell_send_data_v1_3.exe` program. It also has the ability to query the `update_read_local_v2_2.exe` and receive the initial calibration constants that are present on the signal conditioner.

The program outputs a green or red light if the sensor is within or not within tolerance. It also has the output of the two trigger signals that are used to trigger the `update_read_local_v2_2.exe` to read or write the calibration constants on the `config.ini` file located on the NCAP. It also sends the updated values of the calibration constants to be written on the signal conditioner.

## **3. Flow of Data Within the Program**

The flow of information has many channels. The diagram of the VI is shown in Figure 23. The first channel is the IP address and DataSocket channel. DataSocket is a network protocol that is used to transfer data between multiple users. There is more on the DataSocket protocol written in a later section. This channel has a user-defined IP address that it uses to connect to the DataSocket. In this thesis the DataSocket server runs on the NCAP. This process is explained in detail later. The operator must know the IP address of the NCAP in order to receive the information that is transmitted. Once the IP address has been entered, it is then sent to five different subVI's. A subVI is a virtual instrument or code that is located within a LabVIEW virtual instrument. These five subVI's are named `cal_program_v2_1.vi` (CAL prog), `write_trigger_v1_1.vi` (DS write trigger),

read\_trigger\_v1\_1.vi (DS read init), Honeywell\_read\_v2\_1.vi (DS smart sensor) and Crystal.vi (Serial Read). The DS in these titles stands for DataSocket. The other channels of information are located within the subVI's. Each subVI is discussed in detail later in the chapter.

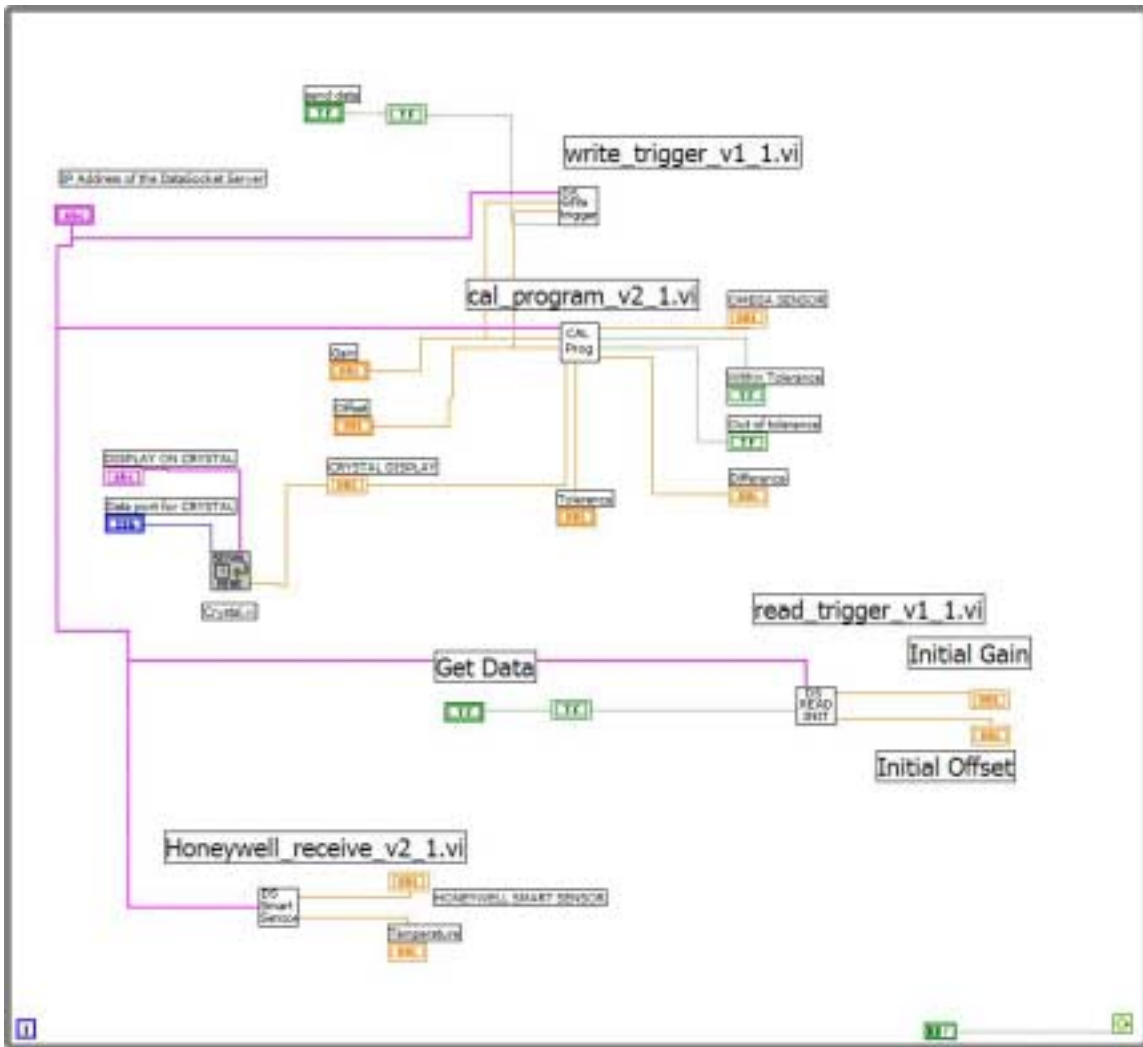

Figure 23. The LabVIEW Diagram of Wireless\_cal\_v2\_2.exe.

a. *Cal\_program\_v2\_1.v1*

This program is the main component of the calibration program. It does the calculations that the operator used to have to do by hand. This alone makes this process more accurate than the old method. The Cal program VI takes in five inputs and has four outputs. It receives the IP address, the calibration constant “gain”, the calibration constant “offset”, the pressure from the calibration standard and the tolerance (percentage). It receives these values and then calculates and outputs the pressure from the sensor, the difference between the sensor and the standard, the signal to turn on or off the red out-of-tolerance light, and the signal to turn on or off the green within-tolerance light. The Cal program uses the IP address to receive and transmit data using the DataSocket protocol. This is discussed in detail in a later section. Once the Cal Program has the voltage transmitted from the sensor, the program uses the gain and offset, entered by the operator, to calculate the pressure. The method to convert the voltage to a pressure is a linear formula. When plotting the voltage versus the pressure, the result is a straight line with slope that is equal to the gain and an  $x$  crossing equal to the offset. The tolerance is a percentage range of the input from the calibration standard. These are the calculations that the program completes for the user. The fact that the computer is calculating whether the sensor is within or not within tolerance makes the new process more accurate than the old process. There are no longer any fudge factor errors that can happen when the operator believes the sensor is close enough to the tolerance. The computer accurately tells the operator whether or not the sensor is within or not within tolerance.

***b. Write\_trigger\_v1\_1.vi***

This subVI is used to write the new calibration constants to the config.ini file on the NCAP. The config.ini is the file that the signal conditioning program uses to calculate and then send the data to be displayed. This program has four inputs and no outputs. The inputs are the IP address, the calibration constant gain, the calibration constant offset and a write Boolean trigger. The program uses the Boolean trigger to activate a true/false loop that, while the trigger is false, sends a trigger signal of false to update\_read\_local\_v2\_2.exe, and, when it is true, sends a positive trigger and the values of the gain and offset to be written to the config.ini file.

***c. Read\_trigger\_v1\_1.vi***

This subVI reads the current values that are written on the config.ini file on the NCAP. The operator triggers this program first to get the current calibration constants from the signal conditioner. Then the operator can dial those into the system and adjust them from that point. The program has two inputs and two outputs. The two inputs are the IP address and the read trigger. This is used to send a positive trigger to the update\_read\_local\_v2\_3.exe program that enables the program to read the calibration constants from the config.ini file. These values are then displayed on the HMI.

***d. Honeywell\_receive\_v2\_1.vi***

This subVI is used to import the data from the Honeywell PPT. It has one input and two outputs. The input is the IP address and the outputs are the pressure and the temperature from the Honeywell sensor. It uses the DataSocket protocol to receive the data from the sensor via the NCAP.

*e. Crystal.vi*

This subVI queries and reads the data from the Crystal digital test gauge. It has one input and two outputs. The input is the port number that the USB Bluetooth serial port adaptor is located. The outputs are the string display from the digital test gauge and the numerical value of the pressure.

**C. PERCHS\_DAQ\_LOCAL.EXE**

**1. Role in Thesis**

This program resides on the NCAP and can either be running continuously or started by the operator when the calibration starts using the vncviewer.exe program as discussed earlier. It interacts with the resident data acquisition card in the NCAP. The card extracts the voltage signal from the sensor through the daughter boards. The program receives the data from the card and then transmits the data via DataSocket protocol to the laptop/tablet PC.

**2. Inputs and Outputs**

The program allows the user to set the location of the data acquisition card, the number of channels present, the scan rate and input limits. It outputs to the DataSocket server the voltage that is extracted from the data acquisition card. The diagram of the program is shown in Figure 24.

**3. Operating Parameters**

This program can only run for one channel or sensor at a time. A standard data acquisition program that came with the LabVIEW tutorial was used as a starting point and then a DataSocket server writer was added on the output. The biggest change made

was to convert the output array to a cluster and then unbundled the cluster in order to extract a single sensor. Once the single sensor data is extracted, it is then queued with a DataSocket writer and then sent to the server. The possibility exists with more research to make it possible to extract more than one data set at a time.

The program uses two subVI to execute the task. The first has already been discussed and that is the AI Read One Scan. This subVI is the heart of the program. It is a standard VI that was used from the LabVIEW tutorial. It communicates with the data acquisition card and extracts the data that is desired. The other subVI is Launch DS Server if Local URL. As long as “dstp://localhost/” is entered into the IP address section, the subVI starts the data server and connects using the local host IP address. Using this subVI eliminates the need to enter an IP address when the program is started.

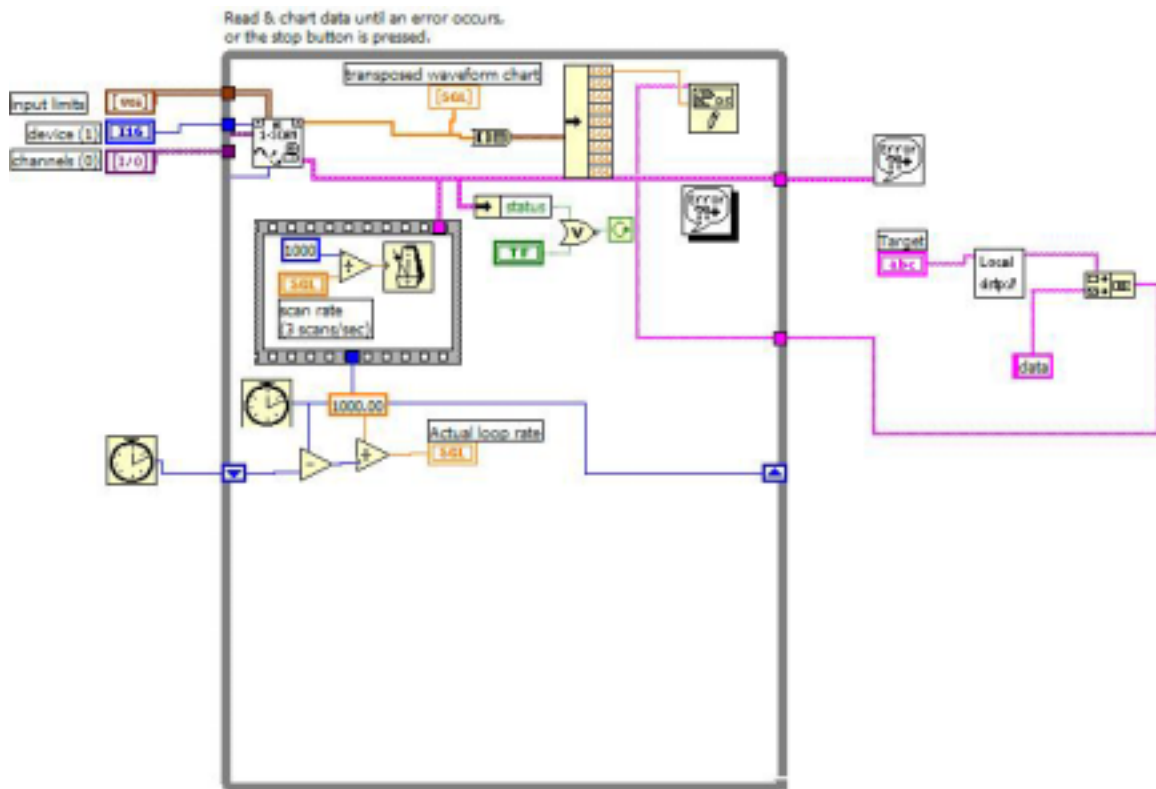

Figure 24. The Diagram of Perchs\_daql\_local.exe.

## **D. UPDATE\_READ\_LOCAL\_V2\_3.EXE**

### **1. Role in Thesis**

This program enables the operator to read and write the calibration constants to the config.ini file. It resides on the NCAP and, like the previous code, can either run continuously or be started by the operator using the vncviewer program.

### **2. Inputs and Outputs**

The program does not need any user interface to run except for the trigger values that it receives via DataSocket protocol from the wireless cal program. It uses the Launch DS Server if Local URL subVI to use the local host IP address as the DataSocket server. The inputs are the IP address and the gain and offset values that we are trying to write to the config.ini file. The outputs are the initial gain and offset values that are present on the config.ini file. Figure 25 shows the diagram of the VI.

### **3. Operating Parameters**

This program uses the Launch DS Server if Local URL to quickly establish the DataSocket server as the local host and to use the local host IP address to connect. There are two true/false loops in the program. They are triggered by the two triggers that are sent from the wireless cal program on the laptop/tablet PC. There are multiple subVI's used in this code, named Open Config Data, Write Key (Double), Double [Read Key (Double)], and Close Config Data. They are used to read or write the data to or from the config.ini file on the NCAP. The Open Config Data subVI uses a given address for the config.ini file and then locates and opens the file so that the user can read or write the

appropriate data to the file. The Write Key (Double) subVI locates the specific line in the file and then write the inputted values over what is already there. The Double [Read Key (Double)] subVI locates the specific line in the file and then outputs what is written on that line. The subVI Close Config Data closes the file after we are all done reading or writing to the file.

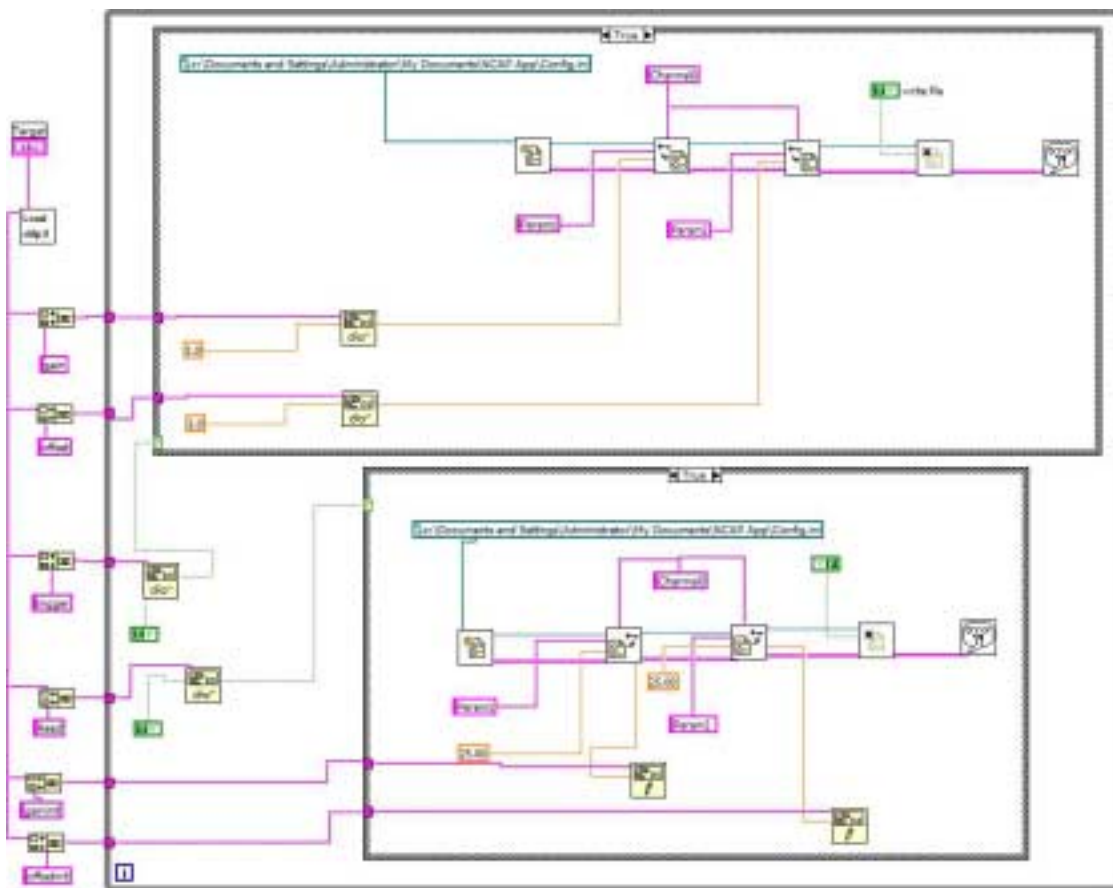

Figure 25. The Diagram of Update\_read\_local\_v2\_3.exe.

## **E. HONEYWELL\_SEND\_DATA.EXE**

### **1. Role in thesis**

This program queries and receives the pressure and temperature that the Honeywell PPT is transmitting. It resides on the NCAP and like the previous two codes can be running continuously or started by the operator at the beginning of the calibration process. It receives the data via the serial port that is located inside the door of the NCAP. Advanced NCAPs allow the sensors such as the PPT to communicate via a specialized daughter card. Since we are using the PPT technology a little before its time, we had to connect the serial port output of the PPT to the serial port located inside the NCAP cover. This is not recommended for shipboard use. This was done only to demonstrate the technology.

### **2. Inputs and Outputs**

The program has two inputs, the IP address and the serial port location. The IP address uses the subVI Launch DS Server if Local URL to quickly establish a connection to the DataSocket server located on the local host. The serial port location tells the code where to look for the data. The output is the pressure and temperature from the PPT. Figure 26 shows the VI diagram.

### **3. Operating Parameters**

The program uses two subVI's. The Launch DS Server if Local URL VI as discussed earlier and the Serial Read (Honeywell\_send\_v1\_2.exe) subVI. The later subVI extracts the data from the serial port. The program then sends it to the DataSocket



the server, which queues the information. It only retains the latest information that was sent to the DataSocket Server. The DS read block accesses the queued information on the server and then extracts it to the program that wants the information. The information that can be stored can be an integer, a double variable, a string, or a Boolean value.

So the process is that each data that is to be sent or received is assigned an identifying label (for example, the calibration constants use the label gain and offset to label the DataSocket used). The server then creates the socket and stores the latest information sent to the server. The server can be located anywhere the user wants, as long as it is accessible to the sending and receiving computer. Once the data has been stored it can be accessed by the DS read block from any computer that has access to the server whether it is connected wirelessly or physically.

## **G. CONCLUSIONS**

This chapter discussed in detail the different Virtual Instruments (VI's) that were used or developed for this thesis. The wireless cal program is the main HMI located on the laptop/tablet PC. The perchs daq program is the primary data acquisition program located on the NCAP. The update read program resides on the NCAP and enables the operator to write or read the calibration constants from the signal conditioner. The Honeywell send program is a special program that accesses the data from the serial port on the NCAP. All of these programs use the DataSocket protocol to send and receive the data to and from each other.

The next chapter focuses on the results that were found in the development of the VI's and the transfer of data. The chapter discusses the lessons learned and talks about whether or not the technology works and how well it works.

## **V. RESULTS AND LESSONS LEARNED**

### **A. INTRODUCTION**

The hardware and software have been shown in the previous chapters. This chapter examines how all the parts came together. The process from beginning to the end is detailed in the following sections. The sections follow a chronological order starting from the concept going all the way to the presentation of the finished product at the SCSS 2003 in Orlando, FL from 7 to 9 April.

### **B. THE CONCEPT**

The concept from the beginning focused on developing a program that would display data from both the sensor and the standard simultaneously on one screen. We had two approaches that we were contemplating. The first was to have two separate windows. One window would have the sensor data and the other would have the calibration standard. The other concept was to try and bring both data to one screen. The first concept would then require the operator to use the data and manually do the calculations required to perform the calibration. This would accomplish the goal, but it was agreed that the second option would be the preferred method. Given the fact that both of the data from the sensors would be on one screen, it is concluded that more could be done than just displaying the data. The computer could be used to do calculations. Unsure if this would be possible, the research was focused in that direction.

### **C. THE BEGINNING**

In the beginning, it was known that a simulated shipboard environment was needed. The goal was to bring together the right equipment needed to do this. With the help of our sponsor, Naval Surface Warfare Center, Corona Division, an NCAP and a

Gateway were purchased from 3eTI. When the NCAP and Gateway arrived, the task was first to find out how they worked. Along with the NCAP and Gateway, the research team already had a PPC and pump combination that was to be used to implement the pressure to the sensor. All that was missing was a sensor.

Not knowing what type of sensor would be needed, the group proceeded using the equipment that was already available. The first task was to simulate a sensor until one was purchased. A 0-to-5 V voltage source was initially used to implement a voltage. After doing more reading on sensors and how they work with the NCAP, a potentiometer was used in place of the voltage source. This was used in conjunction with the LM135 (0 to 5 Volt) daughter board since this board provides 10 V from the 'excite+' pin. The potentiometer was connected in accordance with the NCAP manual Appendix D that discusses the LM135 daughter board. [Ref. 4, p. D i-vi] There are six pins available for each sensor. The LM135 daughter board uses four of them. The first four pins ('input\_lo', 'input\_hi', 'excite-' and the 'excite+') were used. The 'input\_lo' and 'excite-' pins were connected as one to one end of the potentiometer. The 'excite+' pin was connected to the other and the sweep arm of the potentiometer was connected to the 'input\_hi' side. As shown in Figure 27, a standard data acquisition program that can be found on the LabVIEW examples titled 'Cont Acq&Chart (easy immed).vi' was used. This program was used to simply verify that a voltage was being produced by the potentiometer and then passed through the daughter board to a data acquisition card and then displayed on the screen. We then could adjust the potentiometer to verify that we were receiving real-time information. This was the first step in the process.

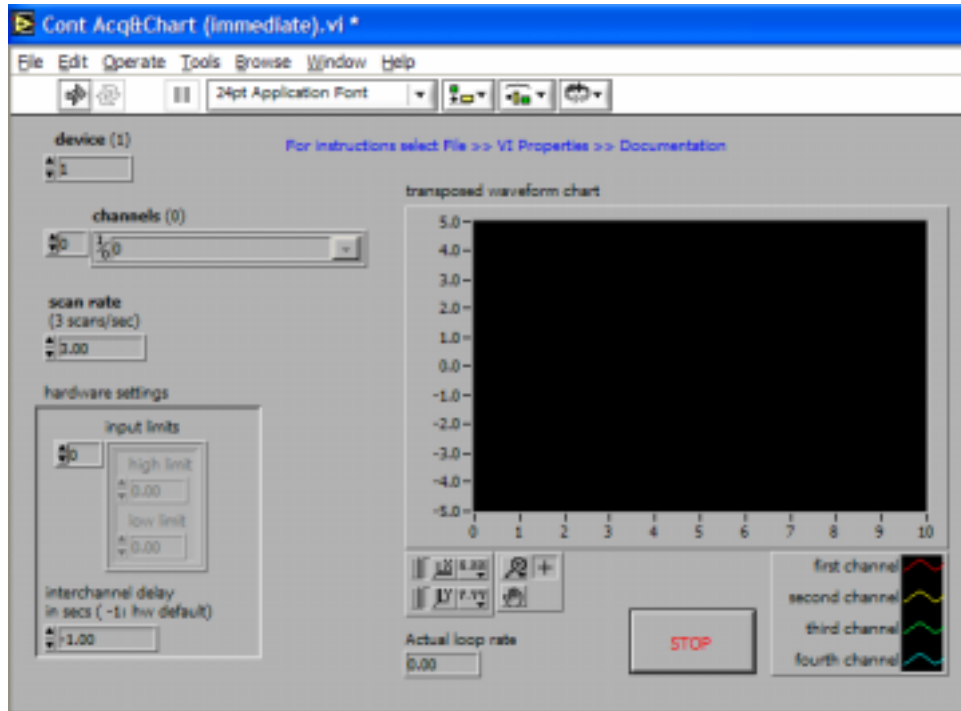

Figure 27. The Display of the Cont Acq&Chart (Easy Immed).vi Program.

#### D. THE ADJUSTMENT PHASE

Once it was determined that we could communicate with the daughter boards and display the information, the next goal was to wirelessly transfer that information to a laptop/tablet PC. First, the wireless LAN needed to be set up.

The NCAP and Gateway were set up to communicate with one another. That is when it was determined that a LINKSYS Ethernet hub should be used as the DHCP server for the LAN. This allowed the Gateway to be used more like it would be used on the ship. Finally the laptop PC was connected to the wireless LAN and a simulated shipboard environment was created. Now we needed to transfer the data from the NCAP to the laptop PC.

To help with the process and become familiar with how the DataSocket protocol works, we started by using test programs that would send a generated random number

using the DataSocket protocol. These programs were named `send_data.vi` and `receive_data.vi`. They are variations of the tutorial programs `DS write.vi` and `DS read.vi`. After a successful test of these programs it was proved that the NCAP could wirelessly send information to the laptop/tablet PC and that data could be displayed on the laptop/tablet PC. Now we needed to prove that we could send the voltage that was seen by the data acquisition program.

The data acquisition program was modified to include a DS write block so that the data could be sent via the DataSocket protocol. This program was called `perchs_daq.vi`. Another program was created to receive the data. This was called `perchs_receive.vi`. It was a variation of the `receive_data.vi` code that replaced the simple plot with the data stream plot found on the data acquisition program. The NCAP was hooked up to a monitor, keyboard and mouse so that the data acquisition could be controlled and verified. There was a problem that the data was being sent was not being plotted properly on the screen. After a good deal of troubleshooting and trying different approaches, the solution finally presented itself. The data that was acquired first had to be converted to a cluster and then unbundled so that the first data stream could be sent. Once this was completed, the voltage that the potentiometer was creating could be sent and plotted on the laptop PC. Now we needed to reproduce this with a sensor.

Two pressure sensors were purchased: a 0.5-to-5.5 V sensor and a 4-to-20 mA sensor. These were chosen because we received two types of daughter boards with the NCAP, one for the LM135 (0.5 to 5.5 V) and the other for the 4 to 20 mA pressure sensor. We chose to use the 4-to-20 mA pressure sensor because it was easier to hook-up to the NCAP. It only required two wires where the 0.5-to-5.5 V required more. Additionally there was not an appropriate excitation voltage readily available for the 0.5-to-5.5 V pressure sensor from the NCAP. The sensor was connected and the experiment was done again to verify that the voltage could be plotted on the laptop PC. The `perchs_receive.vi` code was changed so that the two 'standard' calibration constants of 25

for gain and  $-25$  for offset were used to display the pressure. This experiment was conducted and the test was a success. Now the experiment needed a calibration program.

In parallel to this research there was a separate path being handled. The data from the calibration standard had to be received by the laptop PC. It had been previously demonstrated that the PPC could be controlled a laptop PC using a serial port connection. The next step was to use a Bluetooth serial port adaptor to control the PPC. This was an easy step. The cable was replaced by a Bluetooth adaptor and the code still worked well. The code was enhanced so that it would now query, receive and display the data from the PPC. This code was titled test33.vi and then later changed to Crystal.vi. Once this was accomplished, this code could now be used as a subVI in the calibration program.

## **E. THE FINISHING TOUCHES**

The data from the sensor and the calibration could be displayed on the laptop. The next step was to display both of them on the same screen and do calibration calculations to the data. The program comparison\_code\_ds.vi, shown in Figure 28, was created to receive both the sensor data and the calibration standard, to compare the two values and to determine if the sensor is within tolerance. The code, using the DataSocket protocol to receive the sensor data, passes the voltage through the gain and offset and displays the pressure on an easy-to-read gauge. It received the calibration standard via the Crystal.vi code used as a subVI. That data was displayed on a gauge. Along with the gauge display, a screen display of the data that appears on the PPC was needed to verify that the data was accurate and to help the code complete the loop before proceeding. Without that screen the data would reset to zero after displaying the data. Once that screen was inserted, the data was maintained on the gauge and the calibration calculations could now be done.

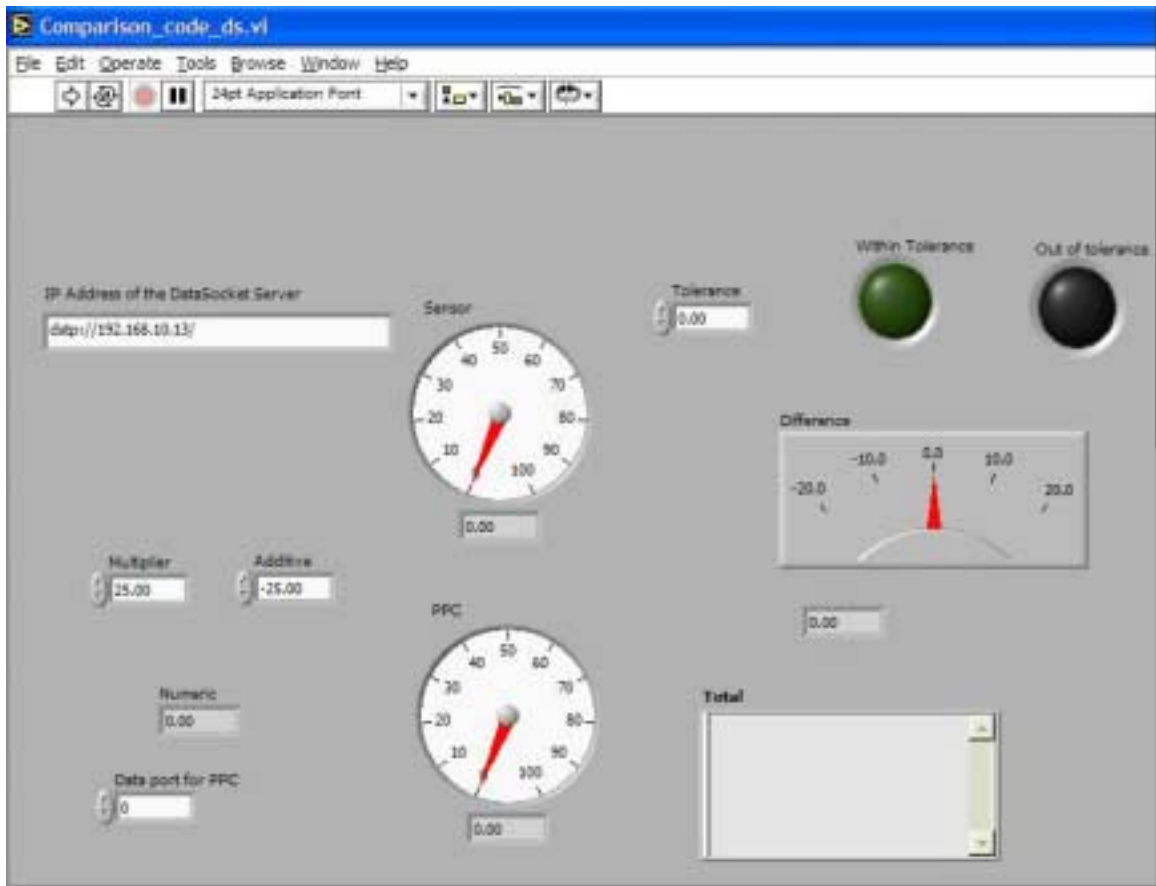

Figure 28. The Comparison\_code\_ds.vi Display.

Both the sensor data and the calibration standard were displayed on the screen, and the difference was compared to a tolerance range of values based on the standards input. This was the first working model of the calibration program. Now the process had to write the data onto the Config.ini file on the NCAP. A new program was developed called Comparison\_code\_update.vi. This program had a toggle switch that would allow the user to send the values of the calibration constants to the NCAP. A companion code was developed that would reside on the NCAP titled update\_config\_trigger.vi. This code received first the trigger value from the comparison code and then would write the gain and offset values to the config.ini file. With these two new programs installed and the test successful, the approach had been proving feasible. The loop was now closed and the method achieved to attain the goal. The team was now scheduled to travel to the Thirteenth International SCSS 2003 in Orlando, FL, so Randy Rupnow and Steve

Glicklick both from NSWC, Corona Division, traveled to the Naval Postgraduate School (NPS) for a week to prepare to demonstrate the program.

During that week there were multiple adjustments made to the code for presentation purposes. The tablet PC was now loaded with the calibration code and it was realized that, in its tablet mode, the tablet PC displayed everything in portrait versus landscape like the laptop PC. Along with that problem the team from NSWC brought with them the Honeywell PPT. Professor Yun, Randy Rupnow and Steve Glicklick quickly developed a code to query, receive and display the data from the Honeywell PPT. The pressure and temperature from the Honeywell PPT was then added to the bottom of the screen of the comparison code. Along with that the screen display was changed to show better on a portrait display and the font was increased on the words and data displayed. The new name of the code was now `wireless_cal_v1_2.vi` shown in Figure 29. This was the version that was used during SCSS 2003. It was also decided during that visit to make the NCAP the default DataSocket server. This accomplished by using the `Launch DS Server is Local URL.vi SubVI`.

Shortly after the symposium the code was updated to now query and display the values of calibration constants that were currently present on the `config.ini` file. The `update_config_trigger.vi` code was updated to now have another part for the reading of the calibration constant values. The test was conducted and the new program was titled `wireless_cal_v2_1.vi`. This is the most current version of the calibration code that has been developed.

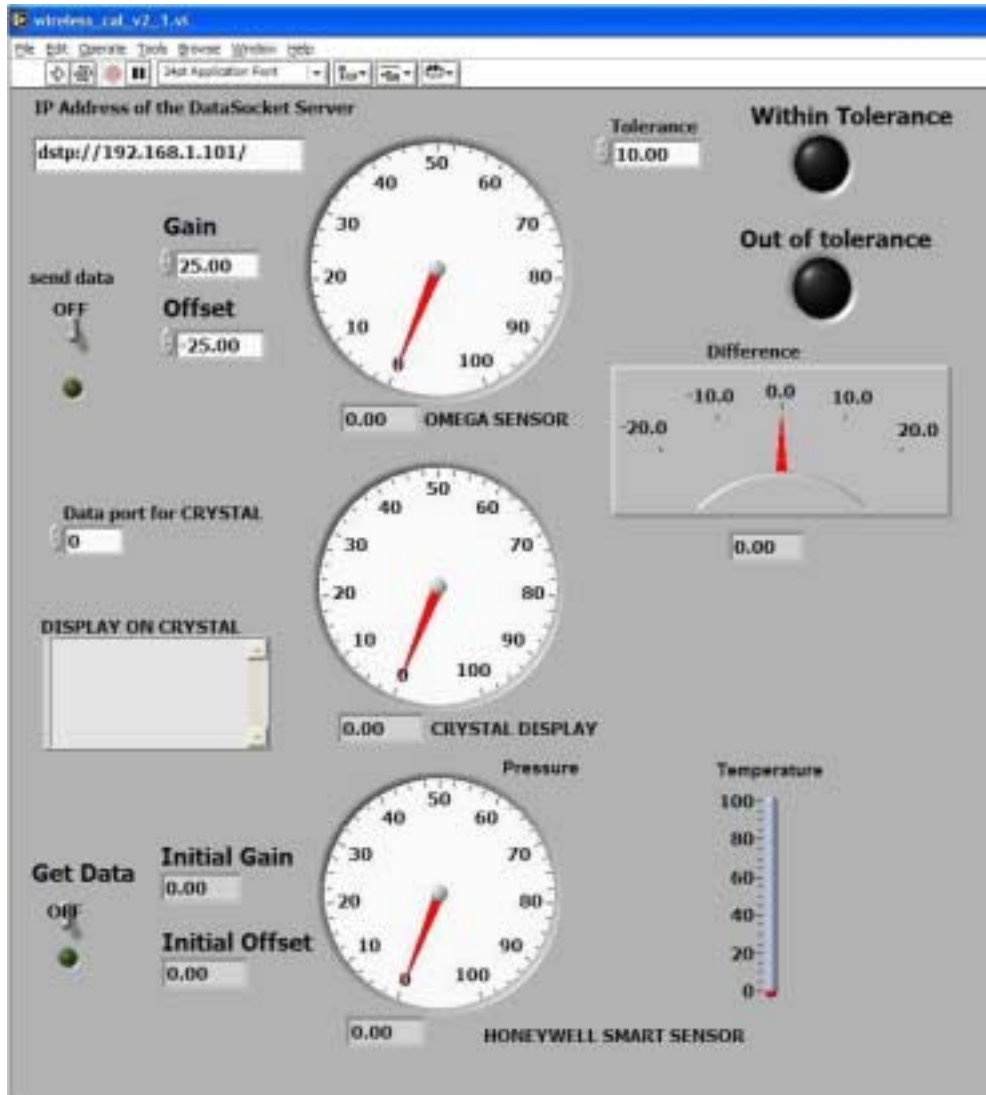

Figure 29. The Wireless\_cal\_v2\_1.vi Display.

## F. THE THIRTEENTH SHIP'S CONTROL SYSTEMS SYMPOSIUM 2003

The team of Professor Yun and myself from NPS, and Jeff Walden and Randy Rupnow from NSWC, Corona Division, traveled to Orlando, FL for the Thirteenth International SCSS 2003 from 7 to 9 April. The team presented to programs such as LPD 17, Smart Carrier, Smart Ship, DD(x), LHD 8 and ICAS. All showed great interest in the presentation and stressed that it was important to have technology like this incorporated into their future projects. Dan Maher NAVSEA 05D3, Ship Design Manager for LPD

17, invited the team to New Orleans to see how this technology could be incorporated into the new LPD 17 ships that were being constructed. Jim Harris from Smart Carrier, per direction of Mr. Michael Tangora, Deputy Assistant Program Manager for Modernization and Innovation for Aircraft Carriers, recommended that we demonstrate the prototype at the Smart Carrier test site (VASIC) in Newport News, VA. Glen Stertavant, Navy Smart Ship Program Manager, and Dave Bartlet, Smart Ship Science and Technology Manager, showed great interest in the project and invited the team to present the work to the fleet customers for wireless innovation. Mr. Michael Iacovelli P.E., Navy lead for DD(x) Ships Systems Controls and Automation, invited the team to present the work to the design agent for the DD(x) Gold team, Northrup Grumman, so that they may evaluate the technology for potential inclusion into the DD(x) ship design. Scott Newell, NAVSEA 05D3, agreed to track the land-based demonstrations of the wireless sensor calibrator and consider this technology for transition. Finally we presented to Mr. Dulio, ICAS Program Manager, and Mark McLean, NAVSEA 05D Director of HM&E Controls, Networks and Monitoring Division, in the Machinery Technology Group and Mr. Dulio agreed to serve as the primary customer for the transition sponsor (NAVSEA 04M SYSCAL Program), for the wireless sensor calibrator and provide an interface to the other potential customers of this technology (DD(x), Smart Ship, Smart Carrier, LPD 17, LHD 8). Mr. McLean talked about how the Navy plans to move to Condition Based Maintenance (CBM) and Reliability Centered Maintenance (RCM) within the Navy Enterprise Maintenance Automated Information System (NEMIAS) Enterprise Resource Planning (ERP) environment. The success of each of these systems relies on the accuracy of a growing number of sensors these systems deploy. The development of effective calibration and maintenance approaches for support of those sensors is of growing concern. Work like this helps subdue some of the concern related to the accuracy and support of sensors.

## **G. LESSONS LEARNED**

There were five main lessons learned from this project.

- Timing is important when incorporating different SubVI's and when talking to other programs running on separate PCs.
- DataSocket server settings must be set so that 'everyhost' and 'localhost' are given permission to read and write
- Bluetooth connection had dropped out on occasion.
- Different LabVIEW versions had trouble working together.
- The reliability of the 3eTI NCAP was discovered in a hard way.

### **1. Timing is Important**

It is important to take into account the timing that occurs when using subVIs. Some programs have an imbedded time delay. If this is true when the subVI is running or waiting for that delay to end, the main program is also waiting for the reply from the subVI. The subVIs are run in series with one another and the program waits for a response before continuing. This can cause problems if the subVI has an embedded time delay that is not needed when running with other programs.

### **2. DataSocket Server Settings**

The DataSocket Server settings must have BOTH 'localhost' and 'everyhost' given permission on for default writer and default reader. 'Everyhost' must mean everyone except the 'localhost' so in order for the calibration constants to be written or read from the NCAP. The server manager located on the NCAP must be changed so that both of the hosts have permission.

### **3. Bluetooth Loosing Connection**

On occasion the Bluetooth connection would be lost for no reason. It seemed to happen more often in a noisy environment such as the lab. It might be related to the fact that the Crystal digital test gauge has an automatic shut off that turns off the test gauge when not used. This is used to save the batteries. This function can be shut-off but the lab group did not know this until recently. Sometimes there was no problem with the Bluetooth connection, but on occasion it would drop out and the user would have to go back and establish connection. This is not a hard process but it is an unwanted annoyance.

### **4. LabVIEW Versions**

It was noticed that programs compiled on newer versions of LabVIEW would not work on older versions of the LabVIEW run-time engine. It is important to take note of which version of LabVIEW was used. This could be averted if the code could be written in Visual BASIC or C++ in order to avoid the use of the LabVIEW run time engine. LabVIEW was excellent for this application except for the version compatibility issue.

### **5. Reliability of the 3eTI NCAP**

The lab group went through four different NCAP's during the research for this thesis. The group was very happy with how the NCAP's worked in the process, but there were problems with the flash memory and with the serial port that needed to be solved. This may have been solved with the updated NCAP that 3eTI has released. The serial port issue is not as important since an actual sensor will never be hooked up to the serial port located inside the NCAP but, when the serial port was initially tried, it took some time to set up and one of the units would only work in one direction.

## **H. CONCLUSIONS**

The entire process from beginning to end has been presented in this chapter. The next chapter discusses the conclusions that were developed from the research and any future work that could be done to add to the already powerful process.

## VI. CONCLUSIONS

### A. INTRODUCTION

Up to now the thesis has presented possibilities or the actual hardware or software. This chapter is a little more abstract in presentation. It contains two brief sections that cover the final conclusions of the research and any future work that could be done to follow this work.

### B. CONCLUSIONS

As previous stated the goals of this thesis were to develop a new process that **reduces personnel** needed to do closed-loop calibration, and **reduces the time required** to do the calibration. The goal was to reduce the personnel by 50% and the time required by 60%. Let us take a look at whether or not each goal was achieved.

#### 1. Reduce Personnel Needed to Do Closed-Loop Calibration

By placing both the sensor data and calibration data on one screen, this goal was achieved. No longer is a person needed to be stationed at the remote display to read the value. Since the minimum personnel needed to do calibration currently is two, by reducing the number of personnel needed to one this is a reduction of 50%. The goal is achieved.

#### 2. Reduce the Time Required to Do Closed-Loop Calibration

There a few factors that go into accomplishing this goal. The first is that all the calculations are no longer done by the operator. This removes a step that the operator needed to accomplish. But this alone does not reduce the time required by 60%. The next factor is that the calibration constants are now written on software on the NCAP. It

has been proven that these constants can be wirelessly written by a click of a button from the laptop/tablet PC. This removes the requirement that the operator needed to pull a signal conditioner card and turn a potentiometer. Once the operator did that step, the calibration process needed to be repeated to verify that the value entered was correct. Now with this technology both of those steps are removed. They accomplished by a simple push of a button. In rough estimates it would take an operator from 30 minutes to an hour to accomplish the change of constants in a system. Now it takes less than a minute. This meets the 60% requirement set by the goals.

## **C. FUTURE WORK**

This work is only a prototype, since it can only be used with one type of sensor and is limited to only one channel from the NCAP. Future work will need to focus on improving the software so that it is not limited. Also it would be critical to be able to display the ICAS display on the screen so the operator can verify that the calibration constants have been correctly written to the NCAP and the remote display is truly accurate. There are also the temperature sensors and accelerometers that have not been addressed in this thesis. Another area is to be able provide the ability to transmit the completed calibration action off the ship to the Immediate Superior In Charge (ISIC) or a shore-based unit designated to track the calibration of certain sensors. This would truly provide a reach-back capability for the maintenance supervisors for certain platforms. Once the data can be stored, the maintenance records of certain sensors types can be tracked and better purchase decisions can be made from this data.

### **1. Improving Software**

There are a few improvements that can be done to the software. It would be desirable to expand the capabilities of the software so that the operator could choose which channel was to be calibrated. Another addition would be to include a data base of sensors that would be installed on the ship with what they are and how they work so that

the program can automatically adjust to the different type of sensors. The program could also be written to automatically calculate the appropriate calibration constants for a sensor.

## **2. Displaying ICAS**

The plan would be to include a display of the ICAS display on the laptop/tablet PC. This is important to verify that, once the calibration constants have been written to the NCAP, the signal is not corrupted further down the line. It also gives the calibrator and the ship's personnel a final check to verify that what is being displayed remotely is the correct value.

## **3. Providing a Reach-Back Capability**

Reach back is the ability to transmit the calibration data off the ship to an ISIC or shore command. This is a long-term fleet application of this technology. The ability allows for ship's force to calibrate sensors and then transmit that data off ship to interested parties such as the ISIC or a designated maintenance monitor who will track the maintenance record of all types of sensors. The reach-back capabilities will aide the planners and purchasers of ship's equipment to make more educated decisions regarding sensor types.

THIS PAGE INTENTIONALLY LEFT BLANK

## **APPENDIX A. WIRELESS CAL V2\_3 USER GUIDE**

### **A. INTRODUCTION**

This Appendix gives a brief users guide to how to use the wireless\_cal\_v2\_3.exe program. It describes what to do when opening the program and the procedures required when operating the program. This Appendix also shows in detail the HMI display and the program code to include the subVI's.

### **B. USERS GUIDE**

Before the user can start operating this program, the following programs **MUST** be running on the NCAP.

- perchs\_daql\_local.exe
- update\_read\_local\_v2\_3.exe
- Honeywell\_send\_data\_v1\_3.exe
- DataSocket Server (this program will start automatically when any of the previous programs are started.)

The IP address of the NCAP must also be known. The Bluetooth adaptor on the tablet PC should be working and the data port entered into the data port block on the display.

#### **1. Procedures**

##### ***a. Start the Program***

After opening the program, the IP address of the DataSocket server should be entered. Also, enter the tolerance value you want to use. Then the arrow button on the top of the screen should be pressed. This starts the program running. The displays for the Omega sensor, PPC and the Honeywell pressures should now be working.

### ***b. Get Initial Calibration Constant Values***

Press the Get Data toggle switch and leave in the 'on' position. The 'Initial Gain' and 'Initial Offset' should display shortly. These are the values of the current calibration factors. Before switching the 'Get Data' switch to the off position, enter the initial values into the blocks marked 'Gain' and 'Offset'. Once those values have been entered, you may now toggle the 'Get Data' switch to off. The values displayed reset to zero. (NOTE: The green light below the toggle switch may not immediately come on. This is due to the timing and delay of the wireless circuit. Once the light is on, the values should appear quickly after that. If they do not, you may have a problem.)

### ***c. Conduct Calibration***

Now pump-up the pressure to where you want to take your first reading. Look at the tolerance lights. If you see a green light, then the sensor is within tolerance for that reading and go on to your next reading. If the red light is on, it means the sensor is out of calibration and the calibration constants need to be changed. Follow the guidance given by your procedures to change the calibration constants. Once the new constants are entered, verify that the green light is lit. You are now ready to update the constants and complete the process.

### ***d. Update Constants on NCAP***

Once you have entered the new calibration constants and the green light is lit, toggle the 'send data' toggle switch to 'on'. Wait for the green light and then switch to 'off'. The calibration constants are now updated. You may move on to another reading point.

*e. Closing the Program*

Once you have completed the calibration, you may now press the red stop button located on the top of the screen. The program will stop running and you now close the program.

**C. DIAGRAMS OF THE PROGRAM DISPLAY AND CODE.**

**1. Program Display**

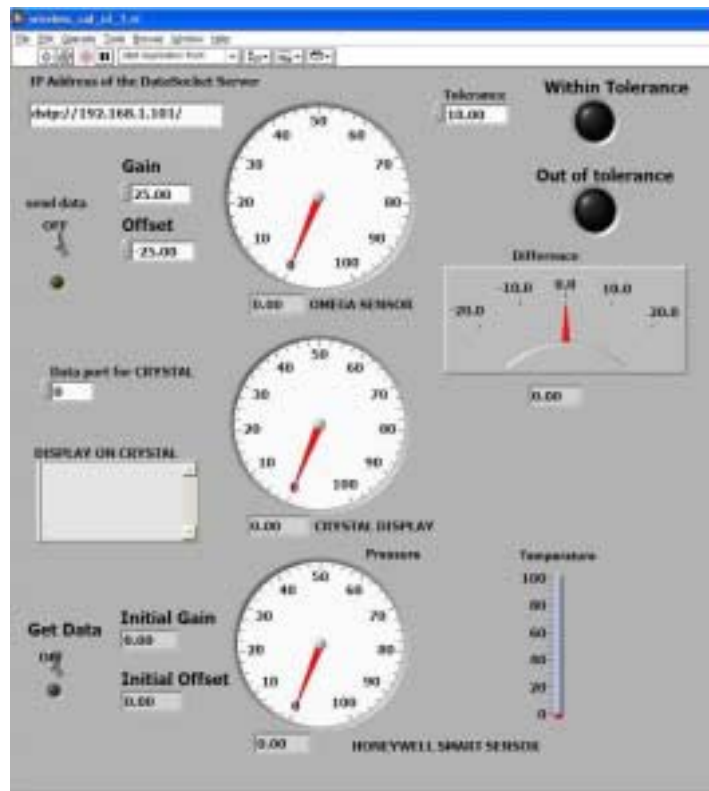

## 2. Program Code

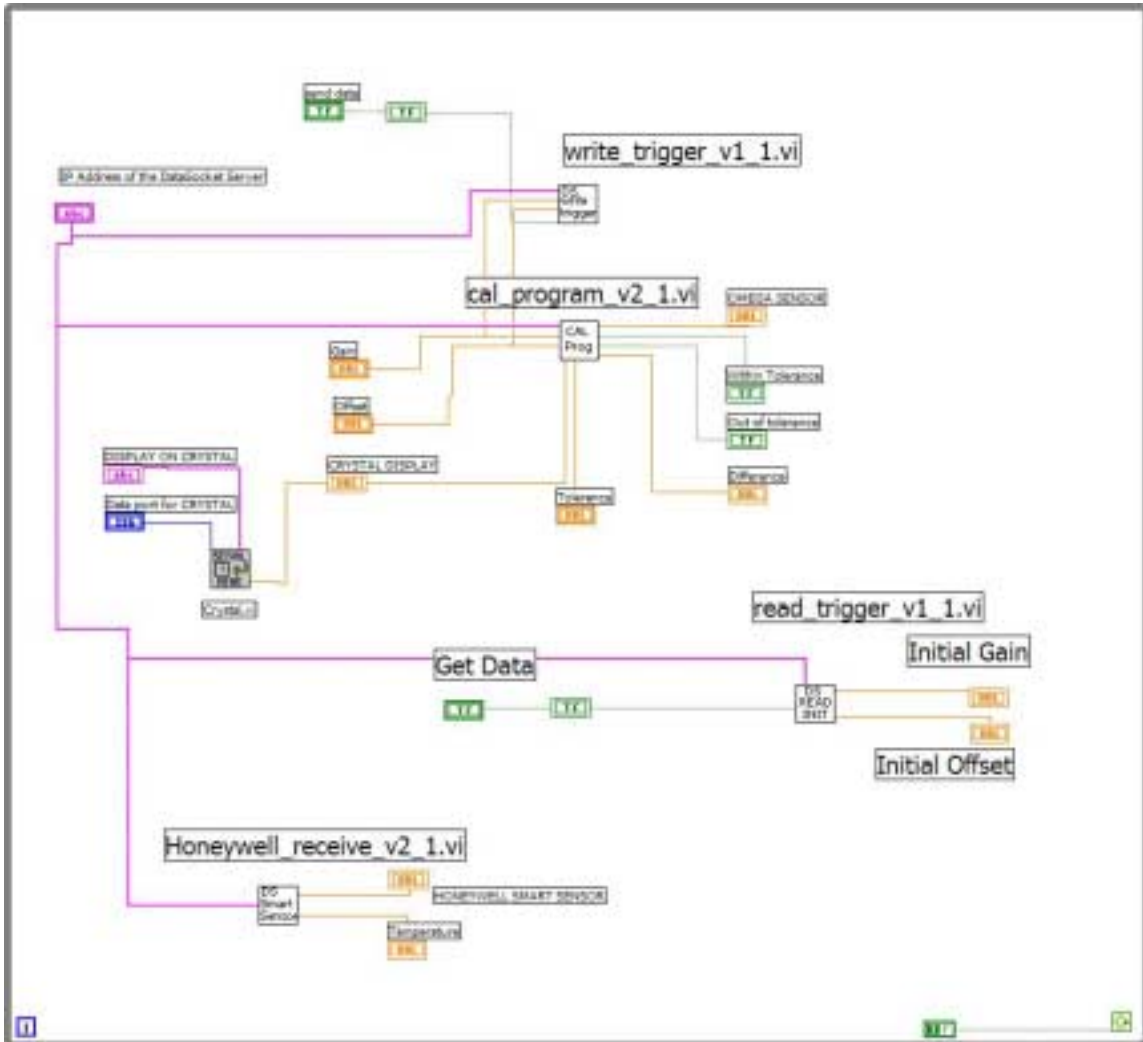

3. Write\_Trigger\_v1\_1.vi Code

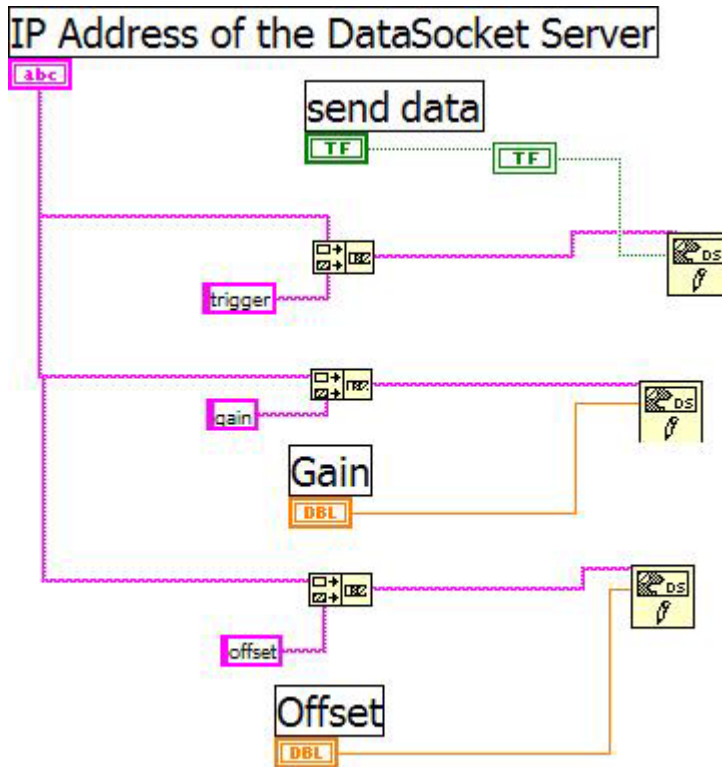

4. Cal\_Program\_V2\_1.vi

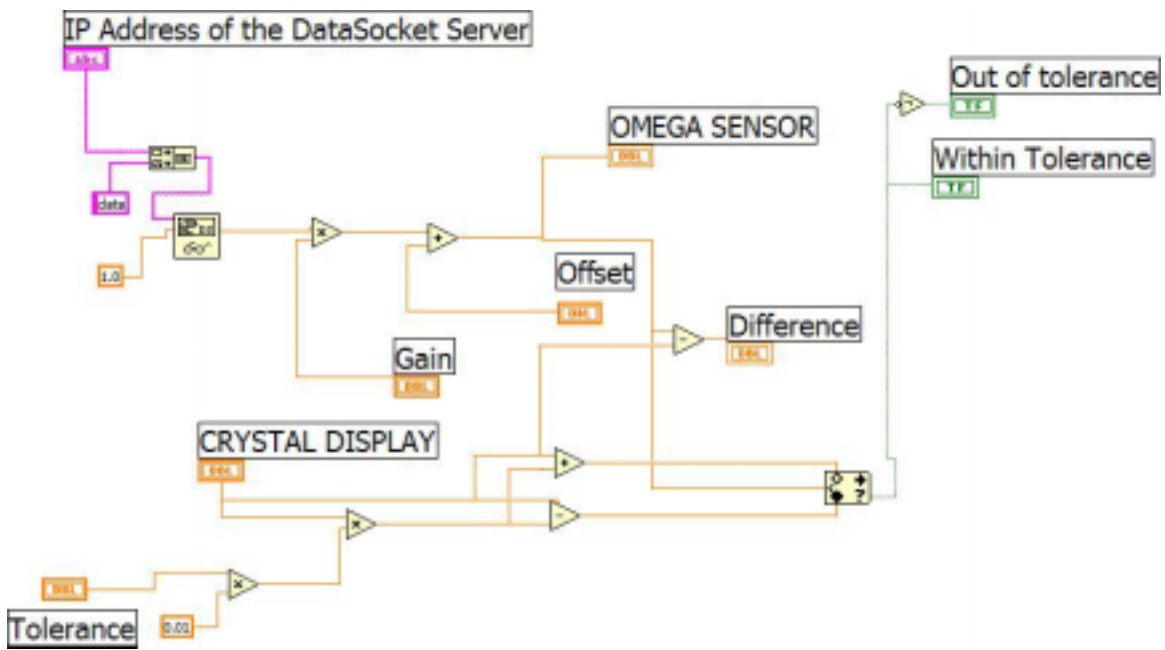

### 5. Read\_Trigger\_V1\_1.vi

IP Address of the DataSocket Server

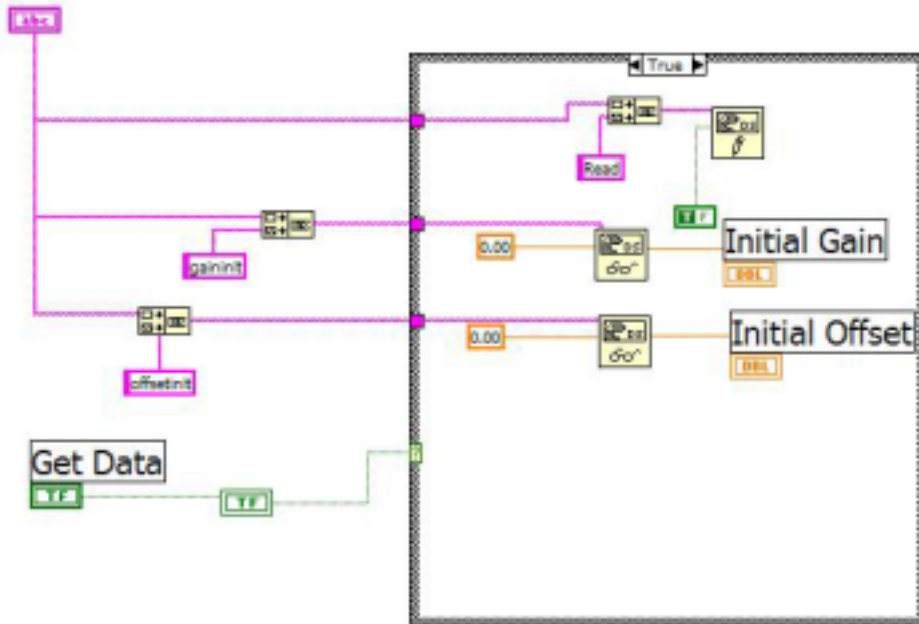

IP Address of the DataSocket Server

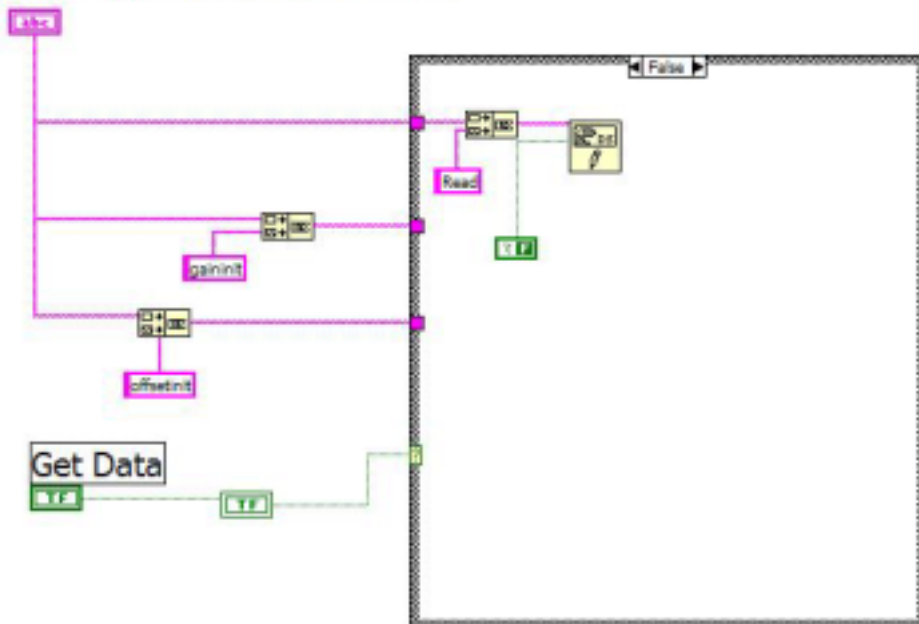

6. Honeywell\_Receive\_V2\_1.vi

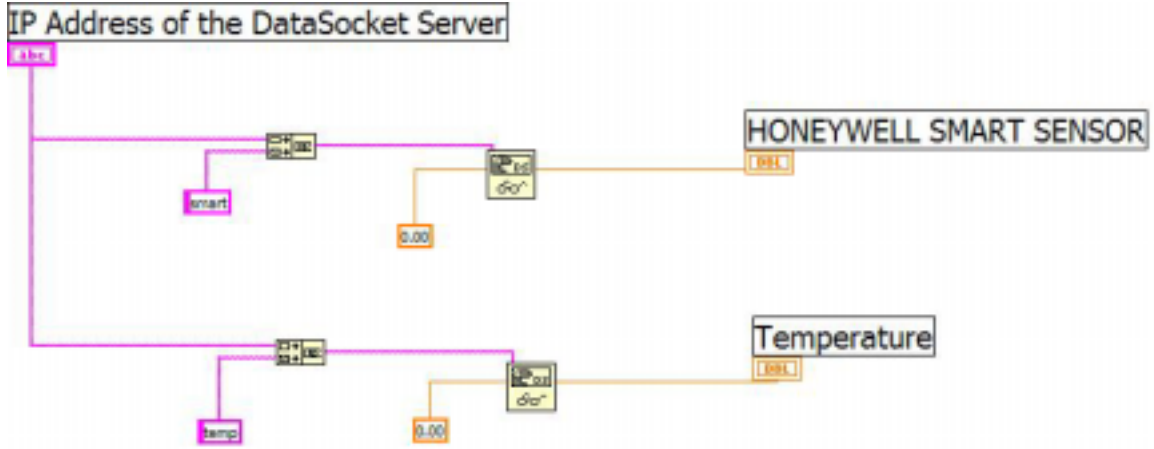

THIS PAGE INTENTIONALLY LEFT BLANK

## **APPENDIX B. PERCHS\_DAQ1\_LOCAL.EXE**

### **A. INTRODUCTION**

This Appendix gives a brief users guide to how to use the perchs\_daql\_local.exe program. It describes what to do when opening the program and the procedures required to operate the program. This Appendix also shows in detail the HMI display and the program code.

### **B. USERS GUIDE**

The shortcut to this program is located on the desktop of the NCAP. It can either be set up to be running continuously or started at the beginning of the calibration process. The vncviewer.exe program located on the tablet PC is used to access the desktop and start the program.

#### **1. Starting Program**

Once the program is displayed, press the single arrow button located at the top of the window. The program starts acquiring data. It also launches the DataSocket server and uses the local IP address as the server. (Note: The DataSocket server program does not appear on the desktop, but the server is running. No more actions are required.)

#### **2. Closing Program**

Once the calibration process is over and the operator no longer needs the program, it can be stopped by clicking on the red stop button at the top of the window. Then the window may be closed.

### 3. Precautions

Ensure that the DataSocket server settings enable permission to both the 'localhost' and 'everyhost' to the DefaultReaders, DefaultWriters and Creators sections. This can be accomplished by opening the DataSocket server manger program located on the Windows start menu. Then, under the permissions groups, add the 'everyhost' to the permissions list. Do not replace, but add the 'everyhost'.

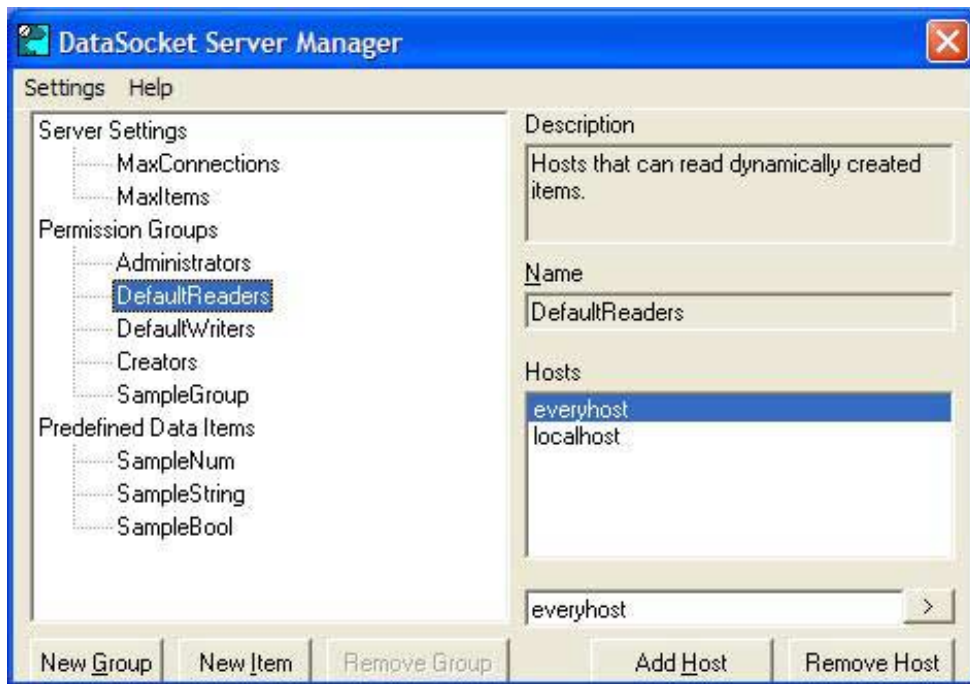

## C. DIAGRAMS OF PERCHS\_DAQ1\_LOCAL.EXE

### 1. Display of Perchs\_daq1\_local.vi

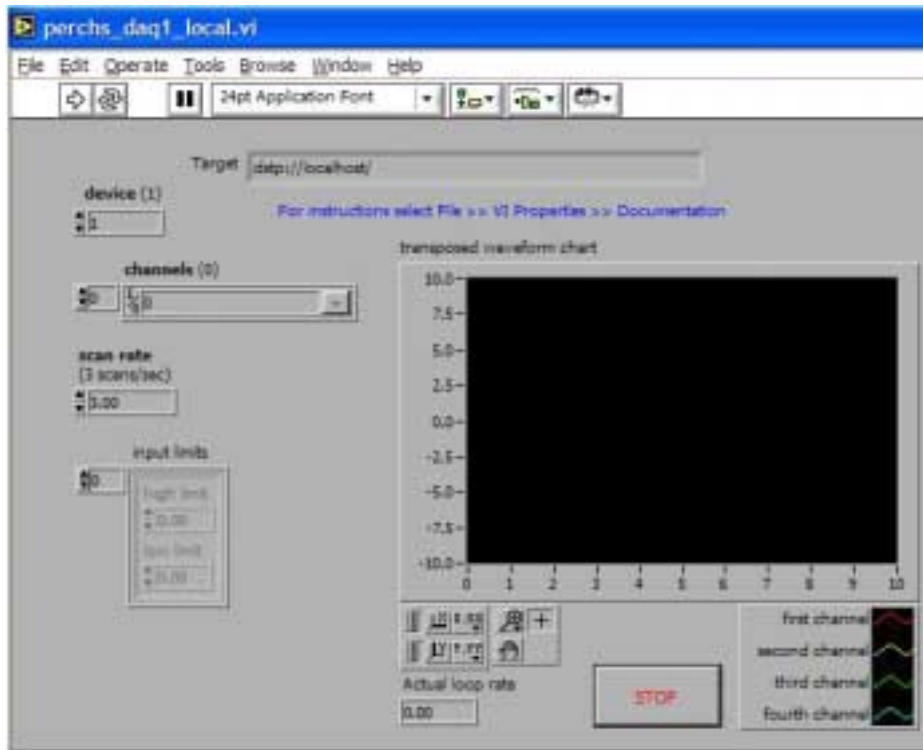

## 2. Diagram of Perchs\_daq1\_local.vi

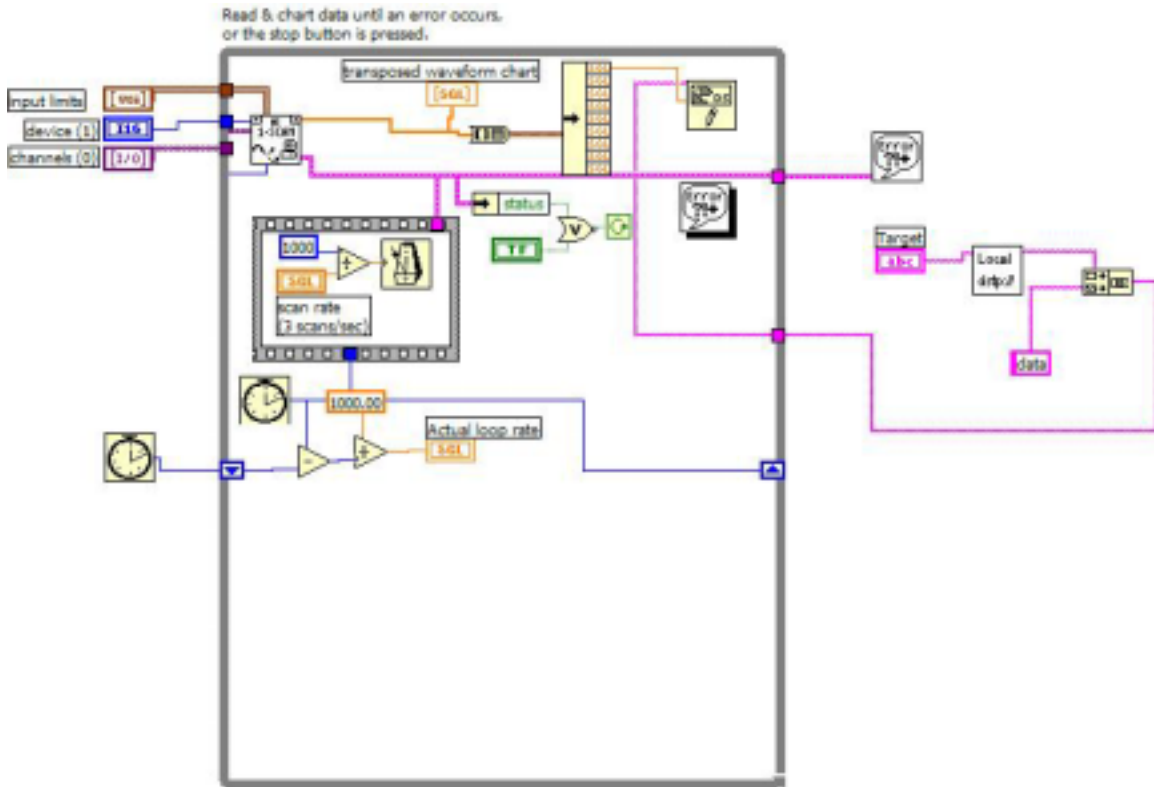

## **APPENDIX C. UPDATE\_READ\_LOCAL\_V2\_3.EXE**

### **A. INTRODUCTION**

This Appendix gives a brief users guide to how to use the update\_read\_local\_v2\_3.exe program. It describes what to do when opening the program and the procedures required when operating the program. This Appendix also shows in detail the HMI display and the program code.

### **B. USERS GUIDE**

The shortcut to this program is located on the desktop of the NCAP. It can either be set up to be running continuously or started at the beginning of the calibration process. The vncviewer.exe program located on the tablet PC is used to access the desktop and start the program.

#### **1. Starting Program**

Once the program is displayed, press the single arrow button located at the top of the window. The program starts and waits for the trigger values from the wireless calibration code. The update read program also launches the DataSocket server and uses the local IP address as the server. (Note: The DataSocket server program does not appear on the desktop, but the server is running. No more actions are required.)

#### **2. Closing Program**

Once the calibration process is over and the operator no longer needs the program, it can be stopped by clicking on the red stop bottom at the top of the window. Then the window may be closed.

### 3. Precautions

Ensure that the DataSocket server settings enable permission to both the 'localhost' and 'everyhost' to the DefaultReaders, DefaultWriters and Creators sections. This can be accomplished by opening the DataSocket server manger program located on the Windows start menu. Then, under the permissions groups, add the 'everyhost' to the permissions list. Do not replace, but add the 'everyhost'.

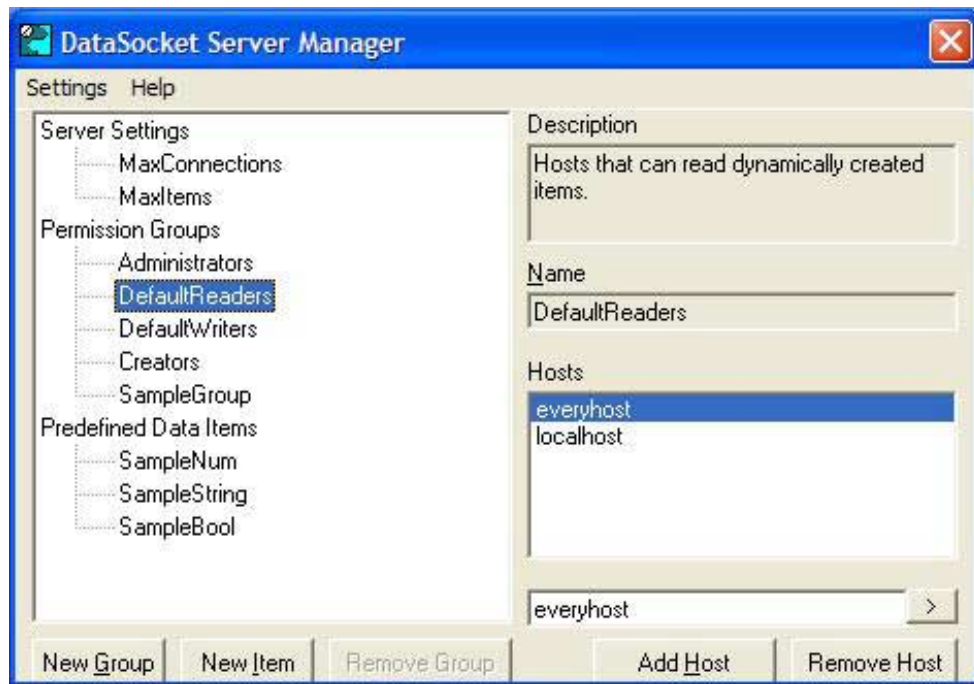



THIS PAGE INTENTIONALLY LEFT BLANK

## **APPENDIX D. HONEYWELL\_SEND\_DATA\_V1\_3.EXE**

### **A. INTRODUCTION**

This Appendix gives a brief users guide to how to use the Honey\_well\_send\_data\_v1\_3.exe program. It describes what to do when opening the program and the procedures required when operating the program. This Appendix also shows in detail the HMI display and the program code.

### **B. USERS GUIDE**

The shortcut to this program is located on the desktop of the NCAP. It can either be set up to be running continuously or started at the beginning of the calibration process. The vncviewer.exe program located on the tablet PC is used to access the desktop and start the program.

#### **1. Starting Program**

Once the program is displayed, press the single arrow button located at the top of the window. The program starts acquiring data. The program also launches the DataSocket server and uses the local IP address as the server. (Note: The DataSocket server program does not appear on the desktop, but the server is running. No more actions are required.)

#### **2. Closing Program**

Once the calibration process is over and the operator no longer needs the program, it can be stopped by clicking on the red stop button at the top of the window. Then the window may be closed.

### 3. Precautions

Ensure that the DataSocket server settings enable permission to both the 'localhost' and 'everyhost' to the DefaultReaders, DefaultWriters and Creators sections. This can be accomplished by opening the DataSocket server manger program located on the Windows start menu. Then, under the permissions groups, add the 'everyhost' to the permissions list. Do not replace, but add the 'everyhost'.

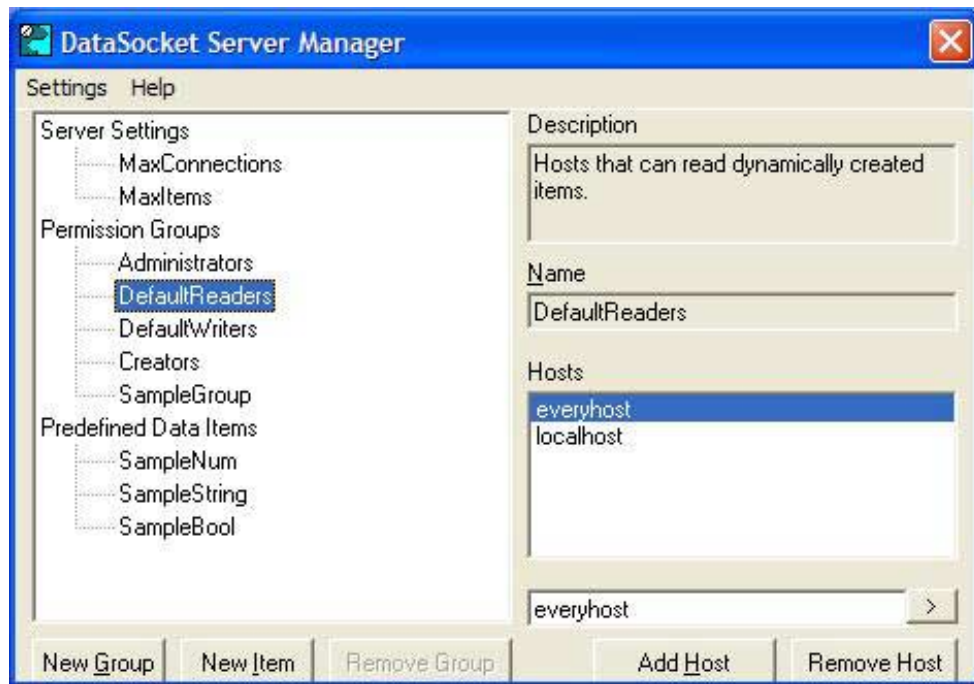

## C. DIAGRAMS OF HONEYWELL\_SEND\_DATA\_V1\_3.VI

### 1. Honeywell\_send\_data\_v1\_3.vi Display

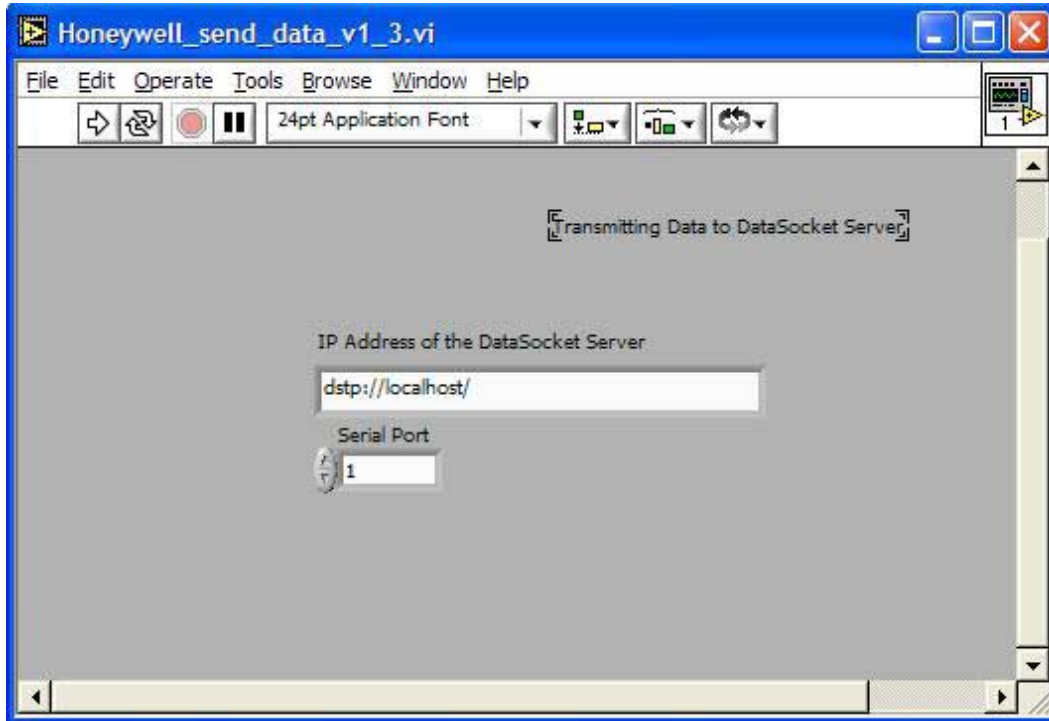

## 2. Honeywell\_send\_data\_v1\_3.vi diagrams

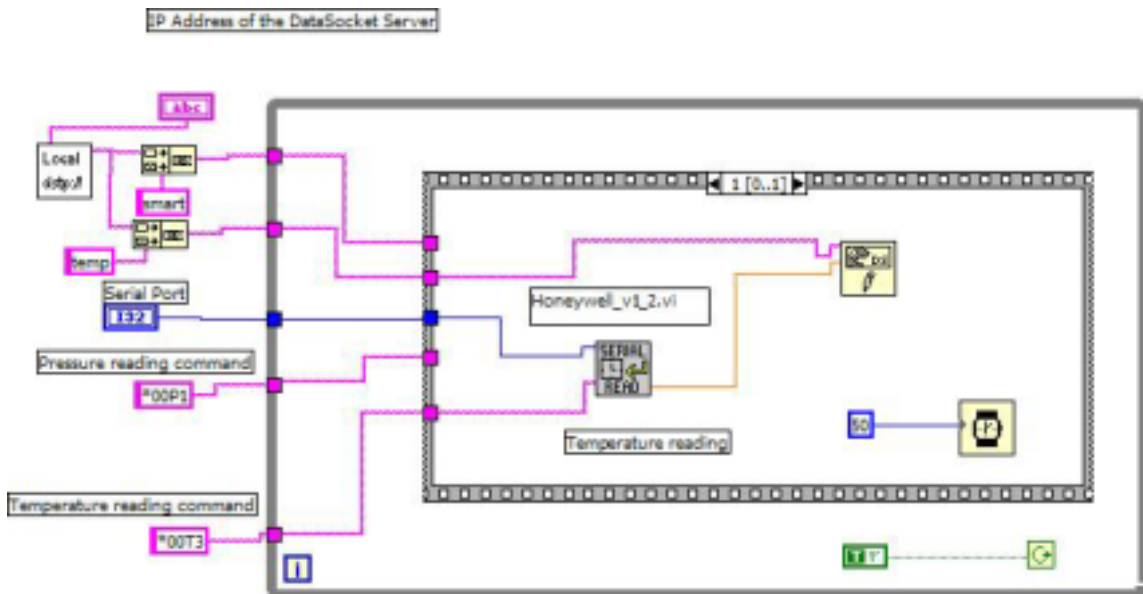
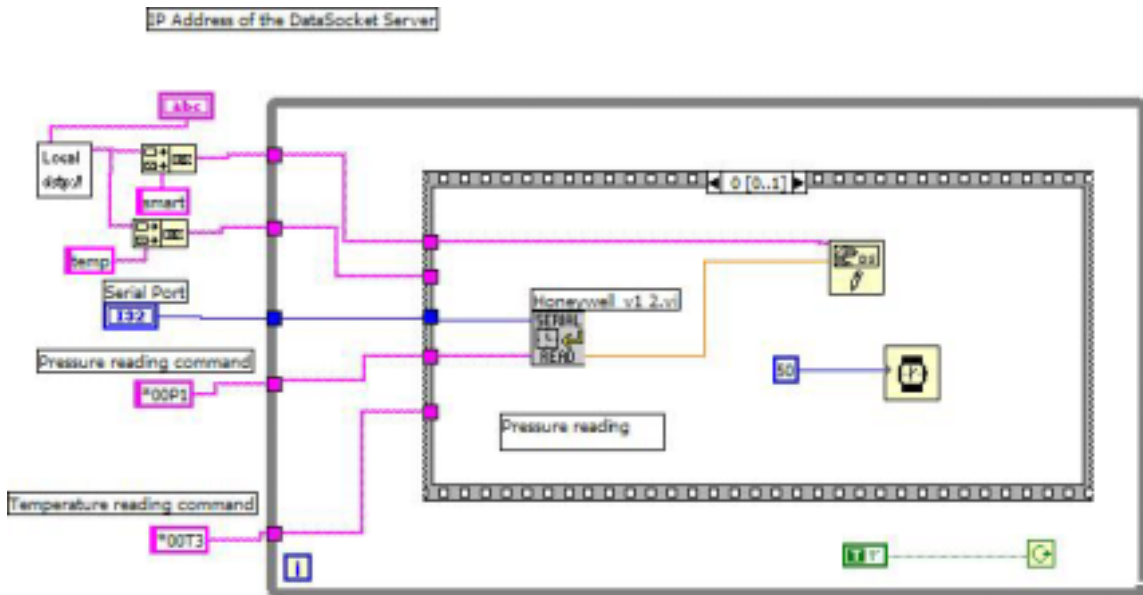

## LIST OF REFERENCES

1. Vern, C., "Sea Power 21, Projecting Decisive Joint Capabilities," *Naval Institute Proceedings*, October 2002.
2. Noguchi, Yuki. "Rockville Firm Hoping to Help the Navy Go Wireless." *Washington Post*, 7 May, 2002.
3. Rupnow, R., Perchalski, S., Walden, J., Yun, X., Greaves, D., Glick, H., "New Calibration Standings for Next Generation Ship's Monitoring Systems," paper presented at the Thirteenth International Ship's Control Systems Symposium (SCSS). Orlando, FL. 7 to 9 April 2003.
4. 3e Technologies International, *3e-550I W-LION Industrial Wireless IO Node*, 3e Technologies International, Rockville, MD., 2002.
5. 3e Technologies International, *3e-521N Series Wireless Dual Mode Gateway User's Guide*, 3e Technologies International, Rockville, MD., 2002.
6. 3e Technologies International, *3e-250 Bluetooth to RS-232 Cordless Adaptor*, 3e Technologies International, Rockville, MD., 2002.
7. CRYSTAL Engineering Corporation, PN: 2975 Rev A, *XP<sup>2</sup> Digital Test Gauge Operational Manual*, CRYSTAL Engineering Corporation, San Luis Obispo, CA., February 2003.
8. TOSHIBA, *Protégé 3500 Series*, Toshiba American Information Systems Inc., October 2002.
9. Honeywell, ADS-14052 Rev. 11/00, *Precision Pressure Transducer PPT and PPTR User's Manual Version 2.4*, Honeywell, Inc., Plymouth, MN., 2000.
10. D-LINK, Rev.2.0, *DBT-120 USB Bluetooth Adaptor*, D-LINK, Taiwan, August 2002.
11. Email From Greaves, D., To: Walden, J., Subject: FW:DDG 87 and WLAN, Friday 25 April 2003, 12:26 PM.
12. Dell<sup>TM</sup>, P/N 1H018 Rev. A02, *Dell<sup>TM</sup> Inspiron<sup>TM</sup> 8200 Owner's Manual*, Dell<sup>TM</sup> Printing, Round Rock, TX, 2002.
13. BELKIN, "BELKIN, connecting people with technology," [[http://catalog.belkin.com/IWCatProductPage.process?Merchant\\_Id=&Section\\_Id=200583&pcount=&Product\\_Id=126318](http://catalog.belkin.com/IWCatProductPage.process?Merchant_Id=&Section_Id=200583&pcount=&Product_Id=126318)], May 2003.

14. OMEGA, *PX202,PX203,PX205,PX212,PX213,PX215 Pressure Transducers M2165/0395*,” Omega, Stamford, CT, 1995.
15. OMEGA, “OMEGA, Your One-Stop Source for Process Measurement and Control!” [<http://www.omega.com/ppt/pptsc.asp?ref=PX205&Nav=preb04>], May 2003.

## INITIAL DISTRIBUTION LIST

1. Defense Technical Information Center  
Ft. Belvoir, VA
2. Dudley Knox Library  
Naval Postgraduate School  
Monterey, CA
3. Chairman, Code EC  
Department of Electrical and Computer Engineering  
Naval Postgraduate School  
Monterey, CA
4. Professor Xiaoping Yun, Code EC/YX  
Department of Electrical and Computer Engineering  
Naval Postgraduate School  
Monterey, CA
5. Professor Fotis Papoulias, Code ME  
Department of Mechanical Engineering  
Naval Postgraduate School  
Monterey, CA
6. Jeff Walden  
NSWC Corona  
Corona, CA
7. Randy Rupnow  
NSWC Corona  
Corona, CA
8. Mark McLean  
NAVAL SEA SYSTEMS COMMAND  
Washington, DC
9. Steven J. Perchalski  
Gaithersburg, MD