

REPORT DOCUMENTATION PAGE

Form Approved
OMB No. 0704-0188

Public reporting for this collection of information is estimated to average 1 hour per response, including the time for reviewing instructions, searching existing data sources, gathering and maintaining the data needed, and completing and reviewing the collection of information. Send comments regarding this burden estimate or any other aspect of this collection of information, including suggestions for reducing this burden to Washington Headquarters Services, Directorate for Information Operations and Reports, 1215 Jefferson Davis Highway, Suite 1204, Arlington, VA 22022-4302, and to the Office of Management and Budget, Paperwork Reduction Project (0704-0188), Washington, DC 20503.

1. AGENCY USE ONLY (Leave Blank)		REPORT DATE 09-06-2003	3. REPORT TYPE AND DATE COVERED Final Report Sep 2002 – May 2003	
4. TITLE AND SUBTITLE Planar Laser Induced Fluorescence as a Diagnostic for Determining Mass Distribution in Gas Puff PRS Loads			FUNDING NUMBERS DTRA01-02-P-0260	
6. AUTHOR(S) Garate, Eusebio Song, Yuanxu Fisher, Amnon				
7. PERFORMING ORGANIZATION NAME(S) AND ADDRESS(ES) Xsci-Tek Inc. 24001 Swallowtail Dr Laguna Niguel, CA 92677			8. PERFORMING ORGANIZATION REPORT NUMBER XST-FR01	
9. SPONSORING/MONITORING AGENCY NAMES(S) AND ADDRESS(ES) Defense Threat Reduction Agency 8725 John J. Kingman Road, MS-6201 Ft. Belvoir, VA 22060-6201			10 SPONSORING/MONITORING AGENCY REPORT NUMBER	
11. SUPPLEMENTARY NOTES This work was sponsored by the Defense Threat Reduction Agency under the SBIR Program.				
12a. DISTRIBUTUION AVAILABILITY STATEMENT Approved for public release; distribution is unlimited			12b. DISTRIBUTION CODE	
13. ABSTRACT (Maximum 200 words) In this work we report on our efforts to develop a laser induced fluorescence system (LIF), using nitric oxide (NO) as the tracer, to determine the mass distribution in a gas puff nozzle assembly used as a z-pinch plasma radiation source load. The same assembly has also been extensively studied at NRL using laser interferometry ans at Titan, Pulsed Sciences Division using LIF with acetone as the tracer. Preliminary results indicate that the NO-LIF, laser interferometry and the previous LIF results agree to within 20%. Concentrations of NO less than 0.1% can be used.				
14. SUBJECT TERMS Z-pinch argon gas puff laser-induced fluorescence laser interferometry			15. PAGE COUNT	
			16. PRICE CODE	
17. SECURITY CLASSIFICATION OF REPORT UNCLASSIFIED	18. SECURITY CLASSIFICATION OF THIS PAGE UNCLASSIFIED	19. SECURITY CLASSIFICATION OF ABSTRACT UNCLASSIFIED	20. LIMITATION OF ABTSTRACT SAR	

NSN 7540-01-280-5500

Standard Form 298 (Rev 2-89)
Prescribed by ANSI Sta. 239-18
298-

20031017 111

TABLE OF CONTENTS

Section	Page
EXECUTIVE SUMMARY	iii
FIGURES	iv
INTRODUCTION AND BACKGROUND	1
TECHNICAL TASKS	
TASK 1: Design, construct and test the LIF chamber and experimental setup.	2
Laser System	2
Optical System	2
Test Chamber	4
Synchronization System	5
Diagnostics and acquisition	6
TASK 2: Perform the LIF measurements.	6
TASK 3: Compare NO LIF, Interferometry and acetone LIF results.	12
TASK 4: Conceptual design of an in-situ PLIF system.	18
DISCUSSION AND CONCLUSION	20
REFERENCES	21

EXECUTIVE SUMMARY

This is the Final Report for Contract DTRA01-02-P-0260 covering the period from September 18, 2002 to May 18, 2003. The main objective of the effort was to demonstrate that laser induced fluorescence (LIF) using NO as the tracer gas can be a reliable diagnostic to determine the mass distribution in gas puff z-pinch loads. The Phase I effort focused primarily on trying to improve previous LIF research on gas puffs which used high concentrations of acetone as the tracer. In our LIF studies we used nitric oxide (NO) as the tracer. Our expectations were that the concentration of NO used as the tracer could be considerably lower than the acetone concentration used in previous studies, which was up to 20%. Also, since NO has approximately the same boiling point as argon, the gas used in the puff valve, we expected there should be little or no problems with clustering that might take place in LIF using an acetone tracer.

The main results of our Phase I effort indicate:

- 1) LIF measurements with tracer concentrations of as low as 0.1% can be made with NO. At concentrations of 1 to 2% the signal to noise ratio is much greater than that for LIF using acetone as a tracer, even for 20% acetone concentrations.
- 2) Comparisons with the previous work done on gas distribution measurements using interferometry at NRL and acetone LIF at Titan indicate our results are in agreement to within 15% at plenum pressures of 10 psia and at a distance of 2 cm from the nozzle. At approximately 30 psia in the plenum our LIF results are within 25% of the NRL interferometry results with the interferometry results indicating higher densities.
- 3) High signal to noise PLIF images can be obtained using NO as a tracer.

FIGURES

Figure		Page
1.	Schematic drawing of the experimental system.	3
2.	Schematic of the LIF geometry.	4
3.	Schematic of the test chamber which houses the puff valve.	5
4.	Block diagram of the timing sequence.	6
5.	Raw LIF output from the CCD for static background fill.	7
6.	Raw LIF output from the CCD for a puff valve shot.	7
7.	Raw PLIF output from the CCD for a puff valve shot.	8
8.	Schematic of the cell used for some static fill tests.	9
9.	LIF signal versus incident laser energy.	10
10.	LIF signal versus gas pressure in the static fill case. Ar/NO is 65 to 1.	10
11.	LIF signal versus gas puff pressure. Ar/NO at 65 to 1.	11
12.	LIF signal versus gas puff pressure. Ar/NO at 1000 to 1.	12
13.	LIF signal versus gas pressure in the static fill case. Ar/NO at 1000 to 1.	15
14.	NO LIF compared to the results of the NRL interferometry work. Ar/NO at 1000 to 1. Plenum pressure in the valve is approximately 10 psia.	16
15.	NO LIF compared to the results of the NRL interferometry work. Ar/NO at 1000 to 1. Plenum pressure in the valve is approximately 30 psia.	17
16.	LIF signal from the gas puff at a plenum pressure of 44 psia. NO concentration is 1%.	17

FIGURES

Figure		Page
17.	Contour plot of the PLIF signal for the data of Figure 7. NO concentration is approximately 1%.	18
18.	Block diagram of in-situ PLIF diagnostic.	19

INTRODUCTION AND BACKGROUND

A key requirement for improved understanding of z-pinch physics is to obtain data on all aspects of the implosion from the initial conditions, through the run-in phase of the implosion to the final conditions. In the case of gas puffs, the gas flow is time-dependent and turbulent with significant axial and radial gradients. Accurate diagnostics for determining the mass distribution in gas puff z-pinch before the current is applied are essential for increasing PRS predictability, efficiency and yield. Poor efficiency, low yield gas puff z-pinch experiments can be directly traced to inaccurate estimates of the initial gas distribution in the load including the radial and axial density profiles, azimuthal symmetry of the gas distribution, and the mass ratio between different gas shells for multi-shell gas puff loading.

The most extensive gas distribution measurements on gas puff nozzles have been carried out by NRL [1]. Gas distributions for the shell-on-shell nozzle used in past Double Eagle PRS experiments were measured at NRL using high-sensitivity interferometry. Recently a proof-of-principle experiment has shown that laser induced fluorescence (LIF) can be a useful diagnostic for determining the gas density profile in a gas puff z-pinch [2]. In LIF, a short wavelength, pulsed laser excites transitions in atoms or molecules in the gas to a metastable state. The atoms relax to a stable state, emitting light at a characteristic wavelength of the atom. The intensity of this fluorescence is proportional to the intensity of the exciting laser beam and the number of atoms in the beam. Imaging the fluorescence normal to the laser beam gives an image with intensity proportional to the density of the atoms at all points along the probing laser beam.

By comparison to a laser interferometer LIF is straightforward and would be much easier to construct as an in-situ diagnostic. To obtain the radial profile in a single shot using laser interferometry would require multiple interferometers to be operated simultaneously. An Abel inversion is then required. Given the requirements on beam alignment for the multiple beams, this is impractical. LIF can provide accurate information which is both temporally resolved (usually to nanoseconds) and spatially resolved (routinely under 1 mm). In contrast, other techniques, e.g., emission and absorption spectroscopy, interferometry, and schlieren/shadowgraphy are averaged over a line of sight, and other spatially resolved techniques e.g., CARS, Raman scattering, and Rayleigh scattering typically have very low signal levels and have not been used to obtain 2-D spatial information. LIF and Planar LIF (PLIF) are routinely used diagnostics to study hydrodynamic flow so there is a wealth of information available on its use [see e.g. 3 to 6]. PLIF has the confidence of the hydrodynamic flow community as a reliable diagnostic.

The proof-of-principle LIF experiments on gas puffs used acetone as a tracer in an argon gas puff. Comparison between these LIF measurements and laser interferometry measurements indicate good agreement at plenum pressures in the gas puff at 10 psia [2]. At higher pressures the results diverge, with LIF yielding significantly higher density than interferometry measurements, possibly due to acetone clustering. Although acetone is routinely used in LIF, it is usually used to monitor combustion processes. In a combustion environment there is little chance of the acetone clustering. However, in the supersonic flow environment of a gas puff temperatures are low enough to cause clustering. As is well known, acetone is a liquid at room temperature. In practice a rather high acetone concentration, 10% or more, is required for low

plenum pressure cases, for example, when the plenum pressure is below 10 psia. This makes acetone LIF an impractical in-situ diagnostic tool in these cases.

In Phase I we carried out LIF measurements using NO as the tracer. NO has approximately the same boiling point as argon so clustering of the tracer gas should not be an issue in interpreting the LIF results. NO is excited by UV (in our experiments we used 193 nm) and fluoresces in the visible, it is a frequently used tracer gas in LIF studies of combustion processes. It has also been used in studies of hydrodynamic flow as a tracer gas in argon [7]. Trace amounts of 1 in 2000 can be used. This is much lower than the >10% acetone used in the preliminary LIF research.

TECHNICAL TASKS

There were four main technical tasks that were to be performed for the Phase I effort. A discussion of each task and the work done follows.

TASK 1: Design, Construct and Test the PLIF Chamber and Experimental System

A block diagram of the experimental system used in our studies is shown in Figure 1. The system can be divided into the following groups; the laser system, the optical system, the synchronization system, the vacuum chamber and puff valve systems and the diagnostics and data acquisition system. A discussion of each subsystem follows.

Laser system: The laser system we used is a Lambda Physik EMG 201 excimer capable of producing up to 0.5 Joules, depending on the gas mixture used, in a 15 ns pulse. The laser can be operated in 'free run' mode with a repetition rate of up to 50 Hz and in a single shot, externally triggered mode. The emission wavelength of this type laser depends on the type of gas used in the laser chamber. In our experiments the laser gas fill was helium, argon and fluorine resulting in an ArF laser with an emission wavelength of 193 nm. The output of the laser is a rectangular beam of approximately 1.5 cm by 4 cm. The largest energy per pulse we managed to extract from the laser was 150 mJ.

Optical system: The optical system consists of a beam shaper which is an adjustable iris so that the diameter of the laser can be changed and therefore the amount of laser energy which is focused into the system. The other components are a calorimeter to measure the laser output for each shot, and a simple UV fused silica lenses to focus the laser beam. In the case of our LIF studies we used lenses with 40 cm, 50 cm and 100 cm focal lengths. This results in an incident laser beam which is cylindrical in cross section but has a waste at the focal point of the lens. For the PLIF studies we used the 100 cm focal length lens to focus the laser light onto a cylindrical

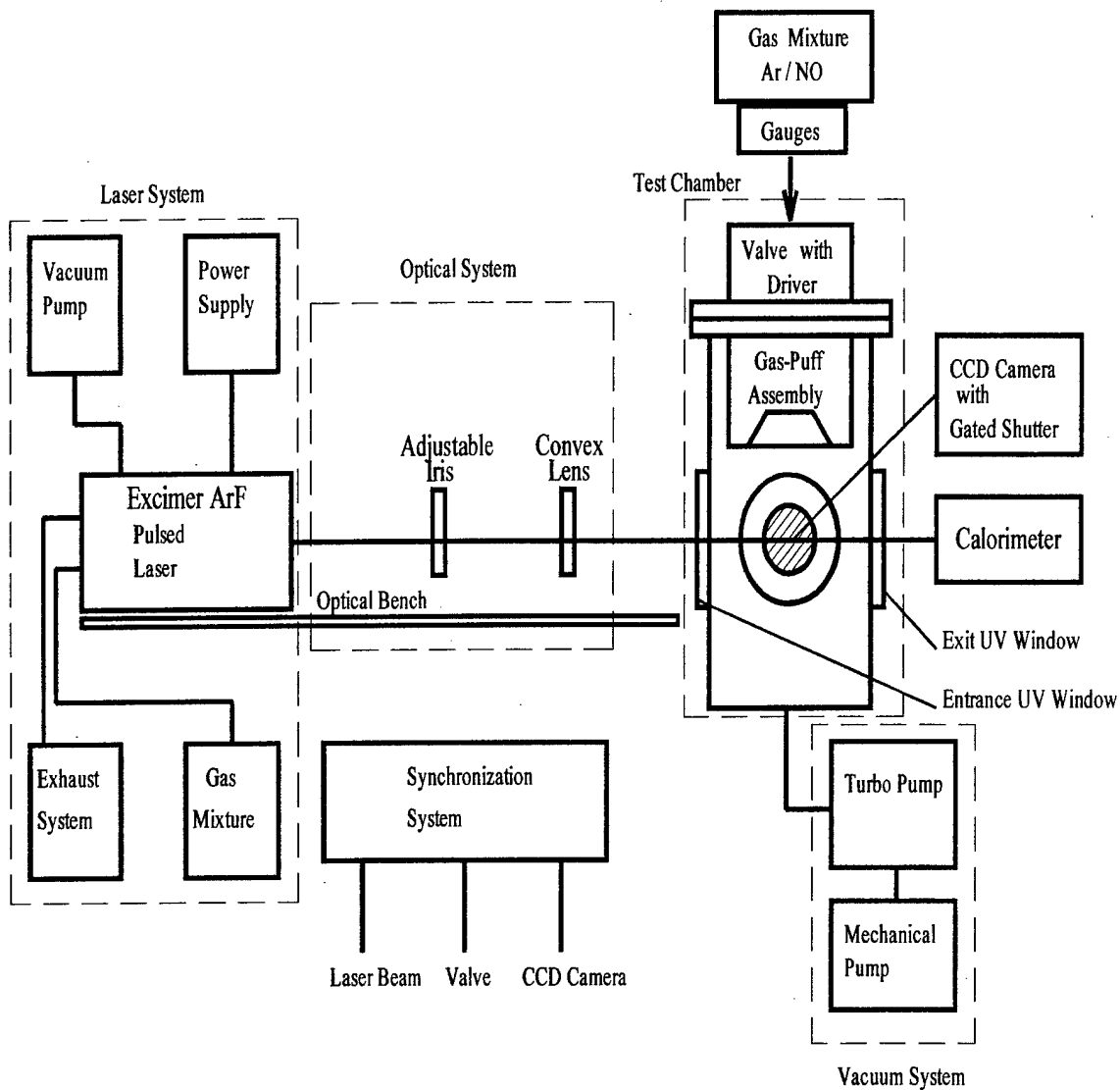

Figure 1: Schematic of the experimental system.

lens which resulted in a sheet beam which entered the chamber. The laser beam enters and exits the chamber through UV fused silica windows. At a right angle to the incident laser beam there is an observation window which the LIF signal is observed through. The observation window is also made of UV grade fused silica. We used several different diameter windows during the course of our research, 25 cm and 50 cm diameter. The LIF signal is then imaged by a single 5 cm focal length UV quartz lens onto a CCD camera. A schematic of the LIF geometry is shown in Figure 2 (taken from reference [2]).

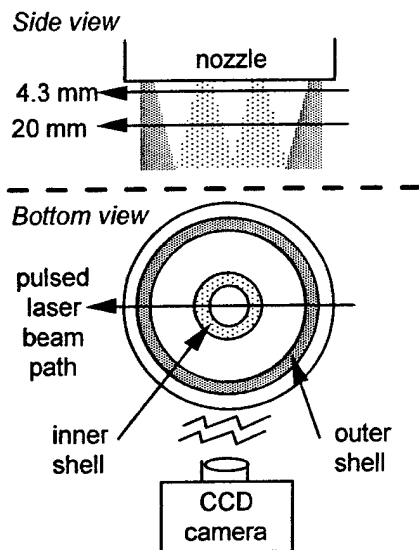

Figure 2: Schematic of the LIF geometry.

Test chamber: The test chamber houses the gas puff valve assembly. A schematic of the test chamber system is shown in Figure 3.

The chamber consists of several different stainless steel pieces including a 10 inch diameter cylinder that is 60 cm long which is mounted to a 6-way cross with 6 inch flanges. The top of the cross has the puff valve and micrometer drive system attached to it. The cylindrical section that houses the puff valve is 30 cm long and 15 cm in diameter. The bottom part of the test chamber has a turbo pump mounted to it which can evacuate the system to better than 5×10^{-6} Torr. The test chamber is mounted in a stand that has adjustable legs so the height of the entrance window can be adjusted relative to the incoming laser beam (see Figure 1). This allows us to adjust the height of the system so that the laser beam enters approximately at the midpoint of the entrance window. The puff valve assembly is connected, via long rods, to a micrometer drive system. The position of the bottom of the puff valve can be varied, relative to the probing laser beam, by adjusting the micrometer.

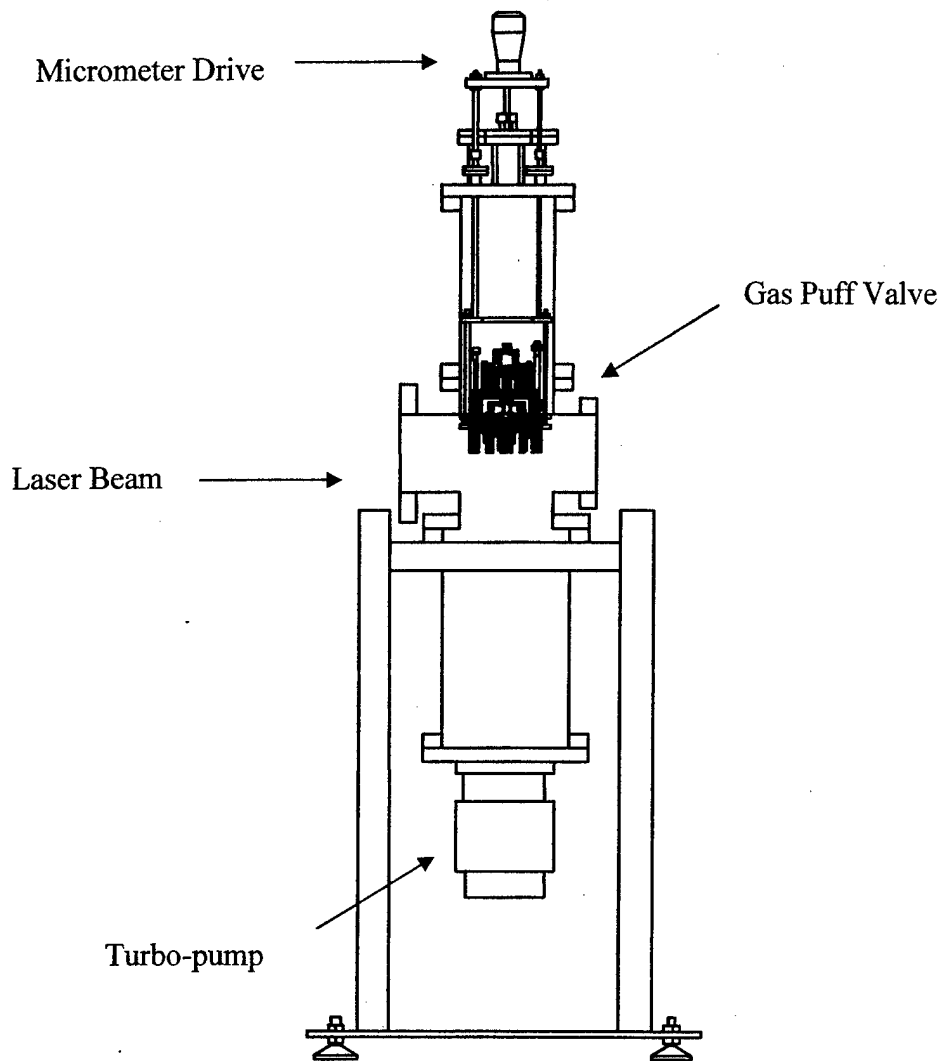
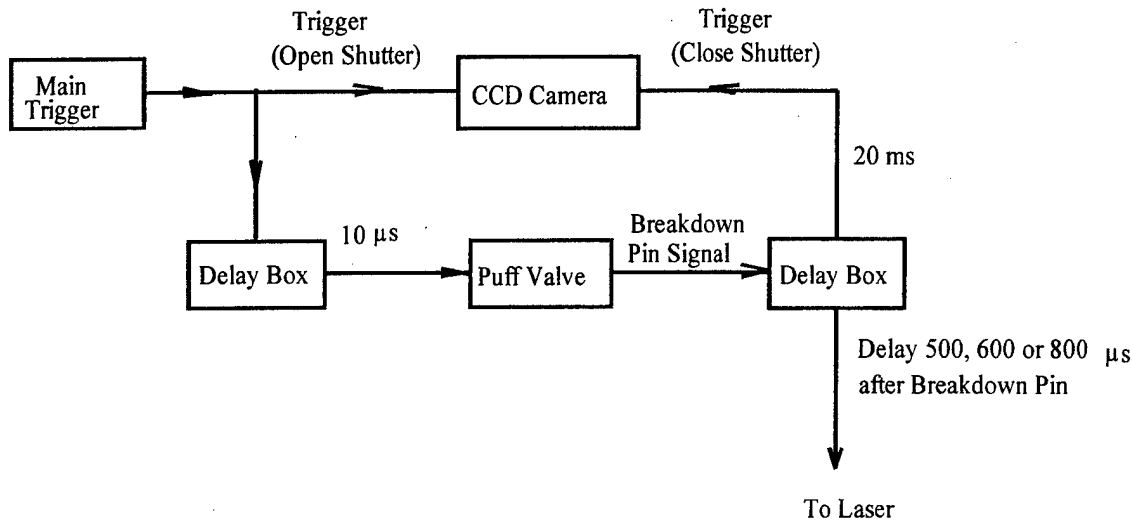

Figure 3: Schematic of the test chamber.

Different locations of the gas distribution can then be probed relative to the end of the valve. The puff valve assembly is connected to the gas cylinder that charges the puff valve by polyflow tubing. Mechanical gauges are used to measure the gas pressure in the puff valve. The pulsed power supply for the puff valve basically consists of a large capacitor and SCR for switching and a charging supply to charge the capacitor. The puff valve and pulsed power supply for the puff valve were obtained from Titan and are similar to the systems used in their LIF experiments. A detailed description of the gas puff hardware is given in [8].

Synchronization system: The synchronization system consists of a set of adjustable delay boxes each with delays up to 10 milliseconds. The timing sequence for a shot is as follows: First a trigger signal is sent to the CCD camera and the shutter is opened, secondly, after a delay of up to several tens of microseconds the puff valve is triggered. The gas flows through the valve and reaches a pre-ionization pin which is biased to -800V. The gas breaks down from the biased pin

and a signal is sent to a delay box. After a suitable delay (we used delays of 500 μs , 600 μs and 800 μs) a trigger signal is sent to the laser which fires. The CCD shutter is closed by a delayed signal approximately 20 ms after the laser is fired. The data is then read out from the CCD. A block diagram of the timing sequence is shown in Figure 4.



Figure

4: Block diagram of timing sequence for the LIF studies.

Diagnostics and acquisition: The fluorescence from the NO tracer gas is imaged by a Princeton Instruments TE/CCD-512SB cooled CCD camera system which was on loan to us from Titan, Pulsed Science Division. Data acquisition is done by downloading the raw data from the CCD to a PC. After the raw data is acquired we produce line images by data analysis which amounts to counting the signal in each pixel of the CCD and then outputting this to a graph. We also use oscilloscopes to capture the timing signals discussed above and to capture the output trace of the calorimeter each shot of the laser.

TASK 2: Perform the NO PLIF Measurements

In all the work carried out in our Phase I effort we configured the excimer laser to operate using ArF with an emission wavelength of 193 nm. This wavelength will excite the NO [B-X] and [D-X] transitions resulting in emission from below 200 nm to about 350 nm. Since the output of the laser is a rectangular beam, we shaped the laser pulse using an adjustable iris and then focused the beam into the interaction chamber using a simple plano-convex lens. For the PLIF studies we used an $f = 1\text{m}$ plano-convex lens to focus the laser light onto a cylindrical lens which then results in a sheet beam which enters the chamber. The energy output of our laser could vary shot to shot so it was important to monitor the laser energy. Therefore, after the laser beam exited the interaction chamber its energy was recorded, each shot, on a calorimeter.

Typical raw data output from the CCD for our LIF studies, where the incident laser beam is cylindrical in cross-section, can be seen in Figures 5 and 6 which are from shots for a static fill of gas in the test chamber and from firing the puff valve, respectively. Figure 7 shows a typical result for our PLIF studies on the gas puff where the incident laser energy is in the form of a sheet beam.

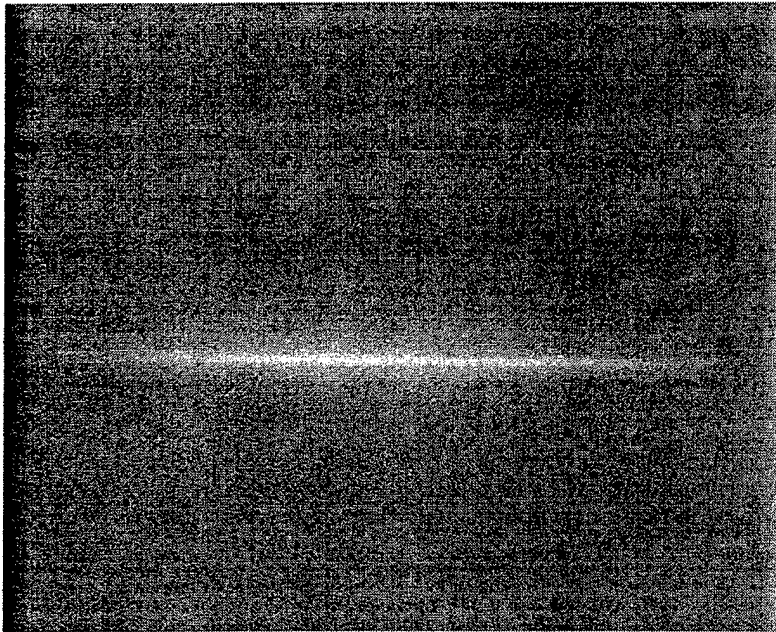

Figure 5: Typical raw LIF signal for the static fill case. The decrease in intensity at both ends of the signal is due to focusing of the laser light by the 40 cm focal length lens. The NO concentration is approximately 1.5%.

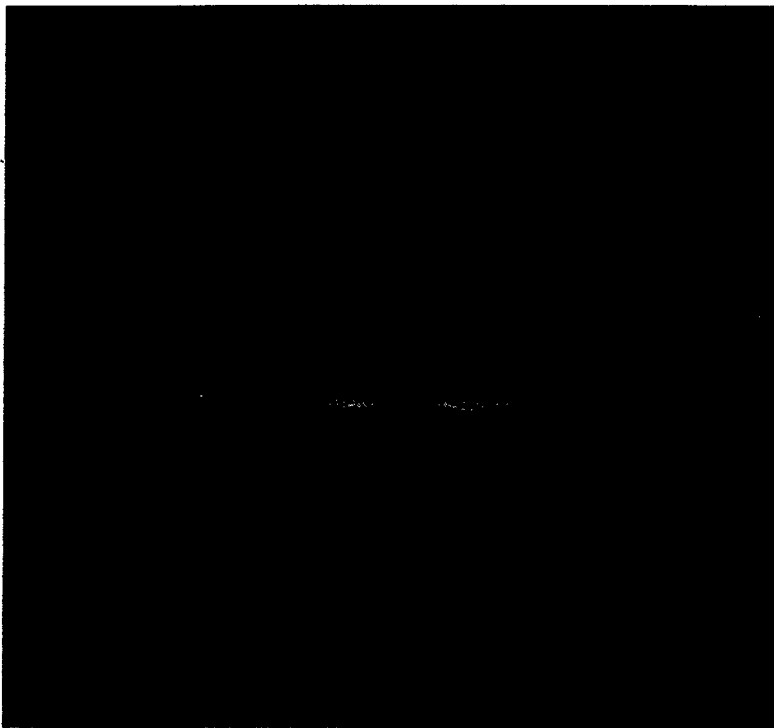

Figure 6: Typical raw data of the LIF signal for a puff valve shot. Here the pressure in the valve was 44 psia. NO concentration is approximately 1%.

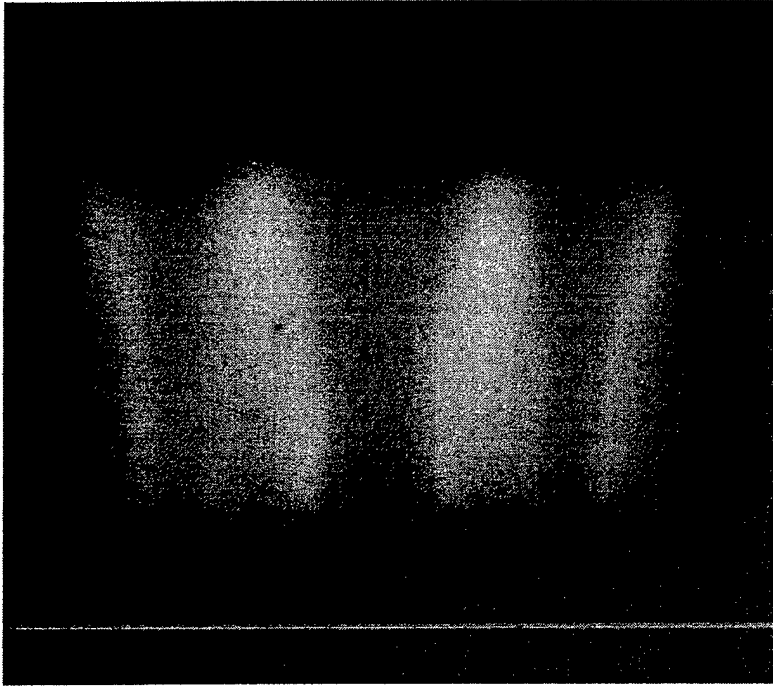

Figure 7: Typical raw CCD data for PLIF of the gas puff. The plenum pressure is 9.7T. The NO concentration is approximately 1%.

The raw LIF CCD images are analyzed by a slightly modified version of the program used at Titan for their LIF studies. Using the program requires the user to choose a line along which to calculate the LIF signal for a group of pixels, the number of which can be chosen as input. The averaged LIF signal is then output as a function of position along the line. The PLIF images are calculated in somewhat the same manner except that the intensity is calculated as a function of (x,y) positions for the CCD image rather than along a single line. The actual path length over which the LIF signal is collected depends on the optics. In our experiments we placed a ruler in the system at the location of the laser beam line and then took an image of the ruler using the CCD. This allowed us to accurately determine the line length which could be viewed by the CCD. Raw data reduced as just described is shown in the section describing Task 3 (Figures 15 and 16).

We conducted a series of experiments to verify that the LIF signal was a linear function of the input laser energy. This way we could correct the data for any changes in the input energy on a shot to shot basis. We did these experiments in a 'test' cell as well as in the system chamber that housed the gas puff assembly. A schematic of the test cell is shown in Figure 8.

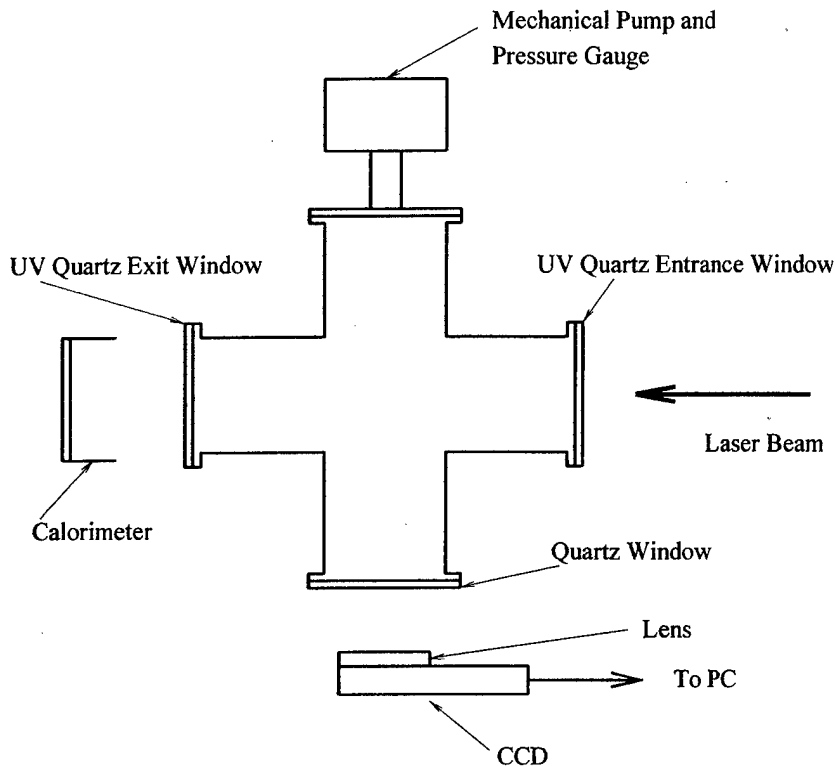

Figure 8: Schematic of test cell used for preliminary studies on linearity of the LIF signal versus energy and pressure.

The cell is made from a stainless steel cross with 2 3/4 inch conflat flanges. We also carried out a series of experiments to determine if the LIF signal was a linear function of the gas pressure in the system. These tests were principally conducted in the main system. The tests for signal linearity with laser input energy and gas pressure were done at different mixing ratios of Ar to NO. The mixing ratios we used varied from 2% NO (50 Ar to 1 NO) to approximately 0.09% NO (1100 Ar to 1 NO). We did the gas mixing ourselves in the laboratory. We chose a piezoresistive pressure gauge to aid in the gas mixing. This is because convectron gauges and thermocouple gauges are calibrated for air and have sensitivities that depend on the gas in the system. We checked the calibration of the piezoresistive gauge against a convectron gauge from 0.5 Torr to 760 Torr using air. All pressure measurements in our Phase I work were done using the piezoresistive gauge.

Representative results for the linearity with laser energy and gas pressure are shown in Figures 9 and 10, respectively. Here we analyze a raw data shot as described above and then we plot the peak LIF signal from the result. It is clear from these figures that the LIF signal is a linear function of the incident laser energy and the gas pressure in the system for the concentrations showed in the figures.

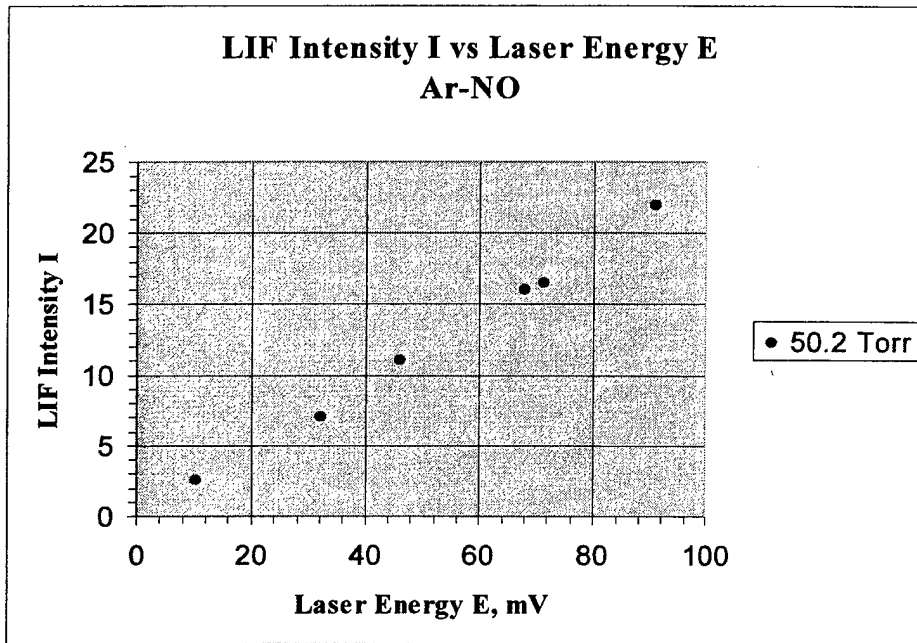

Figure 9: LIF signal versus incident laser energy. Ar / NO mixture is 65 to 1.

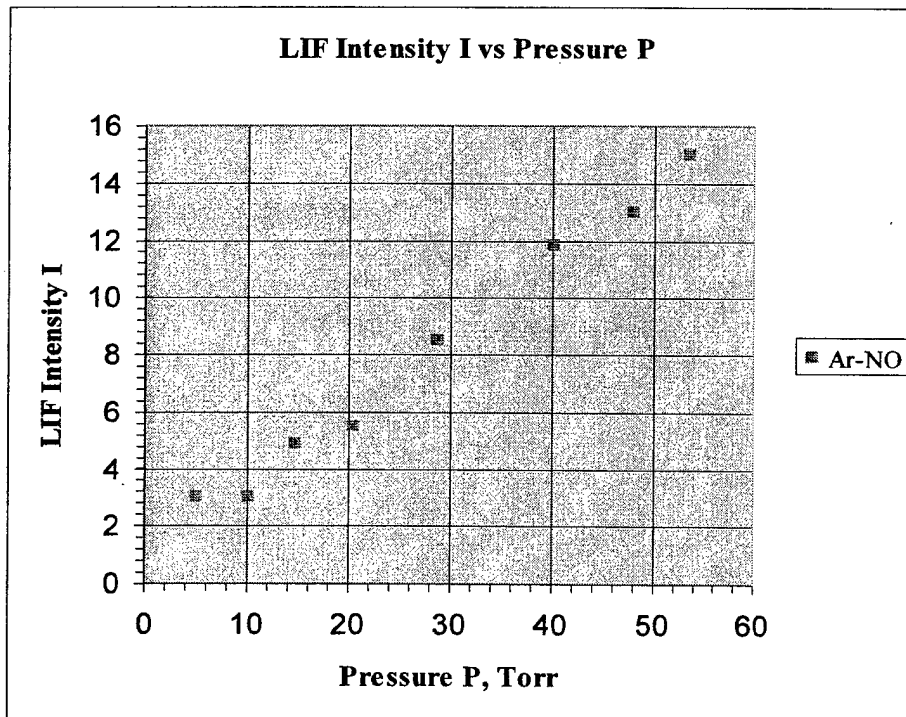

Figure 10: LIF signal versus gas pressure for the static fill case. Ar / NO mixture is 65 to 1.

However, sometimes we did note anomalies in the LIF signal when we used the gas puff and mixing ratios that were high, 1 to 2 %. A representative result that shows these anomalies is Figure 11. Note that at higher pressures the LIF signal begins to saturate (with error +/- 5%). Perhaps at higher pressures collisional deexcitation may be occurring (see discussion in Task 3). Also note the large LIF signal from the puff valve compared to the static backfill case (Figure 9). The LIF signal from the puff valve is several orders of magnitude higher. We still don't completely understand this phenomenon but it is likely related to cooling of the gas in the puff and a decrease in collisional deexcitation.

We noticed other effects in our analysis for much lower concentrations (900 parts Ar to 1 NO), as can be seen in Figure 12. The plateau effect we see in this figure is also typical for the results using low concentrations of NO in Ar. The plateau always occurred for plenum pressures in the 15 to 25 psia region of gas fill. We are not sure at this time whether the anomalous results are due to the puff valve operation at these pressures or if this is an artifact of the diagnostics, although it seems likely that it is due to the puff valve since we do not see plateaus then increases in signal when we do the static fill tests for varying pressures. We note here that the puff valve we used for our Phase I effort was fielded on Double Eagle and had visible signs of erosion. Perhaps this could account for the 'plateau' in the LIF signal.

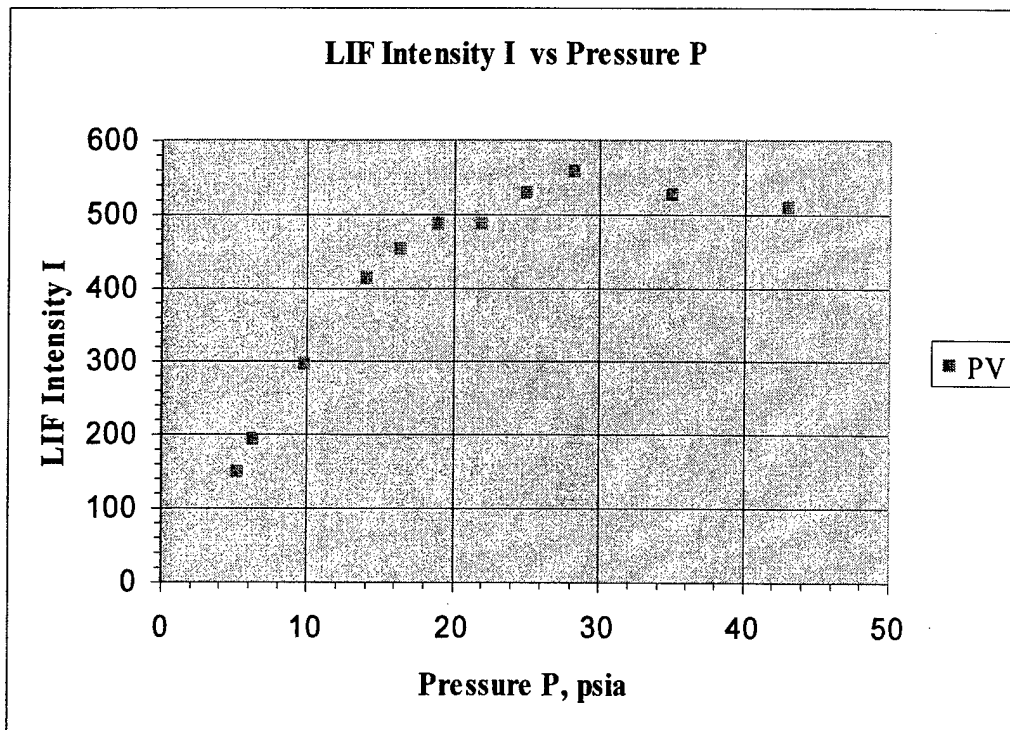

Figure 11: LIF signal versus pressure in the plenum of the puff valve. The peak signal from the inner shell is plotted. Ar / NO mixture is 65 to 1 and the laser energy is approximately 60 mJ.

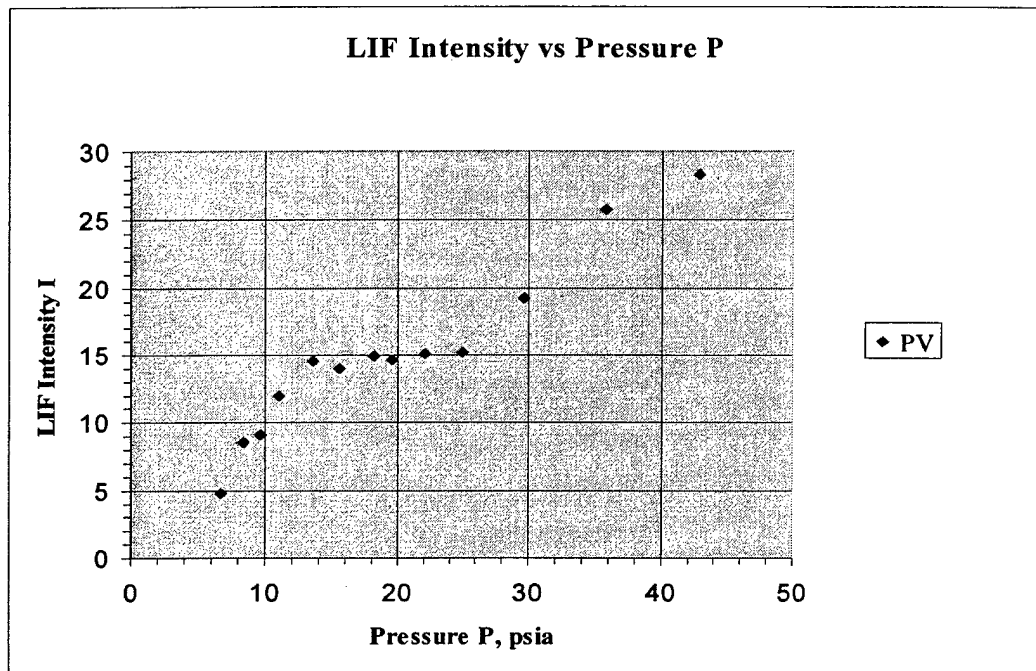

Figure 12: LIF signal versus pressure in the plenum of the puff valve. The peak signal from the inner shell is plotted and the laser is incident about 1 cm from the nozzle exit. Here the concentration of NO is approximately 0.1% and the laser energy is approximately 60 mJ.

TASK 3: Compare NO PLIF, Acetone PLIF and Laser Interferometry Results

We carried out the (P)LIF studies on the same gas puff assembly that had been previously diagnosed by laser interferometry at NRL and by LIF, with acetone as the tracer, at Titan Pulsed Sciences Division. However, before we received the nozzle it had been modified, the inner shell being recessed about 1 cm. In addition, over the past 3 years since it was diagnosed at NRL the gas puff assembly has been fielded many times on Double Eagle and shows considerable wear. Perhaps this wear can account for the 'plateau' we see in the LIF signal versus plenum pressure that is typical of our results. Because of the 1 cm recess, the minimum distance from the valve exit that we could interrogate was approximately 1 cm.

In order to compare quantitatively our LIF results to the gas density distributions of previous work [1, 2] we need to assign quantitative gas density values to the LIF intensities we measure in the gas puff. We measure the LIF signal from the puff valve over a range of plenum pressures and then after the tests we measure the LIF signal from the static backfill in the test chamber. We correct all signals for any scattered light by taking background shots with no gas in the system. However, scattered light is not a significant problem in our setup since the quantum efficiency of the CCD camera is very low at 193 nm.

Both the puff valve and static fill measurements are done without any change in the collection optics and the same NO concentration is used in both cases. By comparing the LIF intensity signals from the gas puff to those of the static fill case we can determine the gas density in the

puff. However, this cannot be done directly without taking into account the temperature and pressure dependence of the LIF signal. The LIF signal, S_{LIF} , is a function of temperature, T , pressure, P , mole fraction of the NO tracer, α_{NO} , and other known experimental parameters and can be written as [9]

$$S_{LIF} = C_{det}(E/A_L)(\alpha_{NO} P/kT)[f(T)Bg(\lambda P)](A/(A+Q(P,T))). \quad \text{Equation [1]}$$

Here C_{det} is a constant accounting for the collection optics efficiency, E is the energy of the incident laser pulse, A_L is the cross-sectional area of the laser pulse, $f(T)$ is Boltzmann's factor which accounts for the population levels of the states excited by the laser, B is Einstein's absorption coefficient, and $g(\lambda P)$ is an overlap integral which accounts for the laser bandwidth overlap with the particular transition. The product of $f(T)Bg(\lambda P)$ can also be considered an effective cross-section for laser excitation. Also, A is the effective rate of spontaneous emission for all direct and indirectly populated states and $Q(P,T)$ is the collisional quenching rate which is a function of temperature, pressure and species of molecule that collides with the NO.

In our experiments the collection geometry does not change for the static fill and gas puff conditions so C_{det} is a constant. We have measured the LIF intensity signal as a function of energy, E , and it is linear as shown in Figure 9, so any changes in the incident energy of the laser shot-to-shot can be easily corrected for in the calculation. The same mole fraction of NO is used in the gas puff and static fill conditions so this is also a constant in the comparison. Therefore to make a quantitative assessment of the gas density we must concern ourselves with the important temperature and pressure dependences which come from the Boltzmann factor, the overlap function and the collisional quenching rate, $Q(T,P)$.

We have studied the excitation cross-section, $f(T)Bg(\lambda P)$, using the program LIFBASE [10]. LIFBASE is a computational program that permits one to determine the LIF excitation cross-section and emission spectrum for transitions in NO, OH, and other molecules. LIFBASE indicates that there are two different transitions that could contribute to the LIF signal, the [B-X] and [D-X] transitions. Both of these transitions should make contributions to the room temperature, static fill LIF results. However, for vibrational temperatures of 200K the [D-X] transition is 'frozen' out but the [B-X] transition still occurs. The [B-X] transition is not susceptible to vibrational temperature but it is frozen out for rotational temperatures lower than 200K and the [D-X] transition is also frozen out at rotational temperatures lower than 200 K. During the calculations of cross-section we assumed that the vibrational temperature of the gas is near 295K which is based on [11] and work done in [2]. In reference [2] it is estimated that the rotational temperature could be on the order of the translational temperature, 15-25 K. This would completely freeze out the both the [B-X] and [D-X] transitions, however we clearly see a LIF signal. Since we have no reliable data on the translational, vibrational and rotational temperatures in the gas flow we will assume the values used in [2] except use a rotational temperature of 250K. This means that both the [B-X] and [D-X] transitions contribute to our LIF signal. The fact that two transitions can contribute to our LIF signal would seem to complicate the comparison between the static filled room temperature result and the gas puff result. However, the emission signal from the [D-X] transition occurs at wavelengths below 225 nm, but the [B-X] transitions are at wavelengths longer than 225 nm up to 400 nm. We believe that the CCD camera is not very sensitive to the [D-X] emission spectra, however, a simple

solution to this problem would be to insert a filter to cut-off the shorter wavelength contributions to the LIF signal. We note from our studies using LIFBASE that a more suitable excitation wavelength would be at 226 nm, the NO [A-X] ground state transition (see Conclusion section).

The final term containing critical temperature and pressure dependence is the collisional quenching, $Q(P,T)$. A model for the P,T dependence of Q can be written as

$$Q(P,T) = (8kT/\pi M_{NO})^{1/2} (P\alpha_{Ar}\sigma/kT). \quad \text{Equation [2]}$$

In equation 2, k is Boltzmann's constant, M_{NO} is the mass of the NO molecule, α_{Ar} is the mole fraction of argon in the gas and σ is the quenching cross-section of the perturbing species, here argon. Given the linear dependence of the quenching rate on pressure and noting the pressure dependence in Equation 1, it is clear that at pressures where the quenching rate is much less than the spontaneous emission coefficient, A , the LIF signal should be linearly dependent on the pressure in the system, i.e.,

$$\text{Lim}_{Q \ll A} S_{LIF} \sim P \quad \text{Equation [3]}$$

for a given laser energy and gas temperature. However, at pressures where the collisional quenching rate is greater than A the LIF signal should be a constant for a given incident laser energy and gas temperature, i.e.,

$$\text{Lim}_{Q \gg A} S_{LIF} \sim \text{Constant} \quad \text{Equation [4]}$$

Both behaviors were observed in our LIF experiments as can be seen in Figure 9 for the linear behavior and in Figure 13, below, for the constant behavior at higher pressures. Note that in Figure 13 the LIF signal could be considered linear with pressure at small pressures and then rounding off to a constant value. It appears as if the region between 1 and 10 T corresponds to the region where the collisional quenching becomes significant. Unfortunately we did not carry out our static filled LIF experiments for pressures less than $\sim 1T$ so we cannot say what the LIF signal dependence on pressure would be at lower pressures than 1T.

These contradictory behaviors were observed for some of our experimental runs and it is still not clear why this is the case. Further investigation is required. We do note that the LIF signal behavior of Figure 13 was observed for our puff valve results only in one instance as shown in Figure 11. The puff valve LIF signal was almost always an increasing function of the gas puff plenum pressure. This could be due to the temperature dependence of the quenching rate. We note that computational gas flow models indicate that translational temperatures can be between 15 to 25 K [12 and see comments in 2]. This would considerably decrease the collisional quenching rate as can be seen from equation 2 (where $\rho_{Ar} = P\alpha_{Ar}/kT$ is the number density of argon atoms), which for a given number density of perturbing argon atoms, depends on $T^{1/2}$.

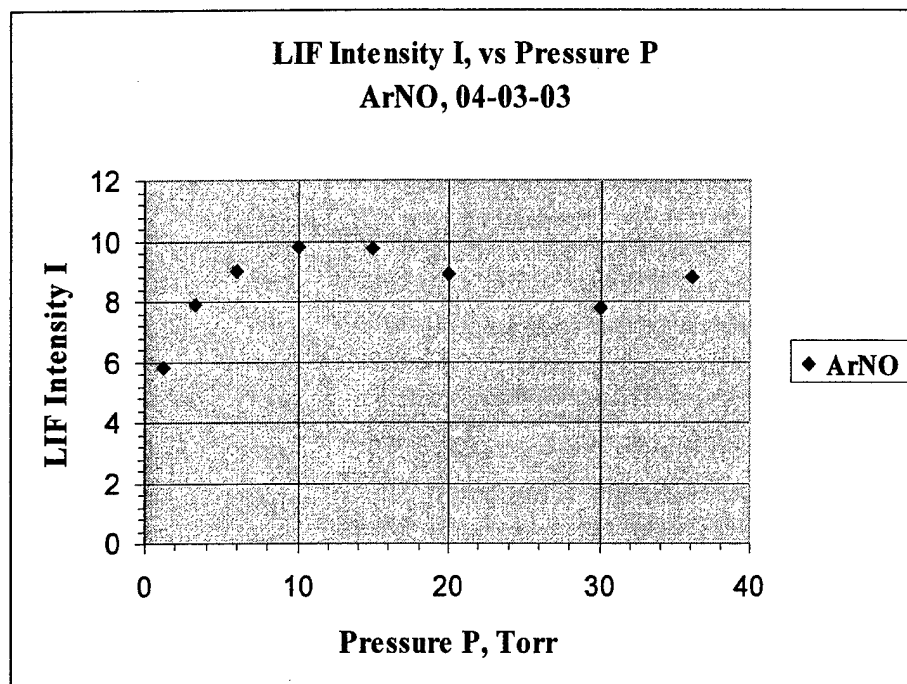

Figure 13. LIF signal versus pressure. Here the NO concentration is $\sim 0.1\%$ and the incident laser energy is about 80mJ. Note that this is the static fill data that corresponds to the puff valve data of Figure 12.

The most straightforward comparison we can make is with the NRL interferometry data and Titan's LIF data [2] for plenum pressures of 10 psia at a distance of 2 cm from the nozzle exit. In Figure 14 we show reduced CCD data for a puff valve plenum pressure of 9.7 psia and at a position of about 2 cm from the nozzle exit. The figure compares data from our NO LIF to the NRL interferometry data. The NRL data, which consists of a discreet set of data points, was taken from [2] and then plotted using a smooth curve through the data set. The 'noisy' trace is the NO LIF result. Our LIF results are also in basic agreement with the acetone LIF studies carried out at Titan, Pulse Science Division [2]. All 3 results are within 15% of each other.

In Figure 15 we show a comparison of our results for the NO-LIF at 32 psia compared to the NRL interferometry results at 30 psia. We stress that in arriving at a density for the gas puff NO-LIF results in Figures 14 and 15 we have used the 'linear' part of the signal versus pressure of Figure 13. This seems appropriate because, as can be seen in Figure 12, the LIF signal amplitude from the puff is less than 10 (the data shown in Figure 12 is taken at a position of ~ 1 cm from the puff valve exit. The LIF signal at 2 cm from the nozzle is smaller).

It is worth noting that at higher NO concentrations we got much higher LIF signals so the signal to noise ratio was much better than that of Figure 14. An example of such a result is shown in Figure 16 where the NO concentration was 1%. We have not been able to reliably assign a density to the LIF signal because, at these concentrations, the static fill LIF signal is much smaller than the gas puff signal for any reasonable density (compare, e.g. Figures 10 and 13). Perhaps by extrapolating the 0.1% static fill results to the 1% case we could assign a density to gas puff LIF signal. We have not looked into this in any detail.

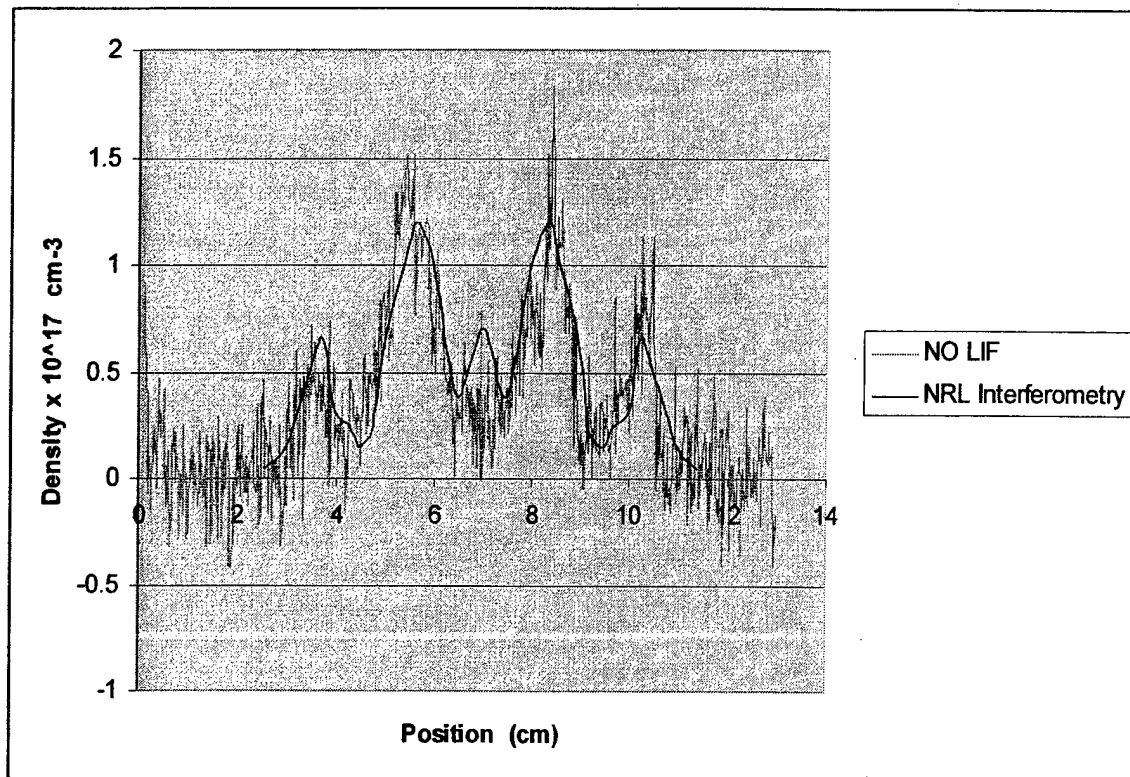

Figure 14: NO LIF compared to the results of the NRL interferometry. The comparison is made for a position approximately 2 cm from the nozzle exit. The plenum pressure in the gas puff is 10 psia. The NO concentration is 0.1%.

We also carried out a series of PLIF studies in which a sheet laser beam is used to excite the gas from the gas puff. Raw data of the PLIF CCD image can be seen in Figure 7 above. All the data we have taken to date in our PLIF studies was done at 1% concentration of NO. We did not have the time during our Phase I work to vary the concentration of NO and do extensive studies of linearity of the PLIF signal versus concentration. Therefore, we are not confident enough to assign gas densities to PLIF signals at this time. A contour map of the PLIF signal in Figure 7 as a function of position in the gas puff can be seen in Figure 17.