

AD \_\_\_\_\_

Award Number: DAMD17-00-1-0465

TITLE: A Novel Method for Determining Calcification Composition

PRINCIPAL INVESTIGATOR: Andrew D. Maidment, Ph.D.

CONTRACTING ORGANIZATION: Thomas Jefferson University  
Philadelphia, Pennsylvania 19107

REPORT DATE: June 2003

TYPE OF REPORT: Annual

PREPARED FOR: U.S. Army Medical Research and Materiel Command  
Fort Detrick, Maryland 21702-5012

DISTRIBUTION STATEMENT: Approved for Public Release;  
Distribution Unlimited

The views, opinions and/or findings contained in this report are those of the author(s) and should not be construed as an official Department of the Army position, policy or decision unless so designated by other documentation.

20031104 098

**REPORT DOCUMENTATION PAGE**Form Approved  
OMB No. 074-0188

Public reporting burden for this collection of information is estimated to average 1 hour per response, including the time for reviewing instructions, searching existing data sources, gathering and maintaining the data needed, and completing and reviewing this collection of information. Send comments regarding this burden estimate or any other aspect of this collection of information, including suggestions for reducing this burden to Washington Headquarters Services, Directorate for Information Operations and Reports, 1215 Jefferson Davis Highway, Suite 1204, Arlington, VA 22202-4302, and to the Office of Management and Budget, Paperwork Reduction Project (0704-0188), Washington, DC 20503

<b>1. AGENCY USE ONLY</b> (Leave blank)	<b>2. REPORT DATE</b> June 2003	<b>3. REPORT TYPE AND DATES COVERED</b> Annual (1 Jun 2002 - 31 May 2003)
--	------------------------------------	--

<b>4. TITLE AND SUBTITLE</b> A Novel Method for Determining Calcification Composition	<b>5. FUNDING NUMBERS</b> DAMD17-00-1-0465
--	---

<b>6. AUTHOR(S)</b> Andrew D. Maidment, Ph.D.
--

<b>7. PERFORMING ORGANIZATION NAME(S) AND ADDRESS(ES)</b> Thomas Jefferson University Philadelphia, Pennsylvania 19107  E-Mail: maidment@rad.upenn.edu	<b>8. PERFORMING ORGANIZATION REPORT NUMBER</b>
--	---

<b>9. SPONSORING / MONITORING AGENCY NAME(S) AND ADDRESS(ES)</b> U.S. Army Medical Research and Materiel Command Fort Detrick, Maryland 21702-5012	<b>10. SPONSORING / MONITORING AGENCY REPORT NUMBER</b>
--	---

<b>11. SUPPLEMENTARY NOTES</b>
--------------------------------

<b>12a. DISTRIBUTION / AVAILABILITY STATEMENT</b> Approved for Public Release; Distribution Unlimited	<b>12b. DISTRIBUTION CODE</b>
--	-------------------------------

<b>13. ABSTRACT (Maximum 200 Words)</b> Calcifications can be divided into two broad categories. Type I are composed of weddellite, while type II calcifications all have some phosphorus content, most typically calcium hydroxyapatite. Type II calcifications are known to be associated with carcinoma, while it is generally accepted that the exclusive finding of type I calcifications is indicative of benign lesions. We are attempting to develop a technique that will determine the composition of calcifications prior to biopsy, thereby allowing one to avoid biopsy on Type I calcifications. We believe that coherent scatter imaging (which is similar to x-ray diffraction imaging) may best determine the chemical composition of calcifications. To date in this grant, we have designed a dedicated detector and are in the process of optimizing image acquisition. We have characterized the detector, in part, and have characterized specific raw materials to determine a basis set for compositional analysis. We intend to validate this design using a clinical trial of surgical biopsy specimens prior to histology.
--

<b>14. SUBJECT TERMS</b> Breast Cancer, Mammography, Pendant Mammography	<b>15. NUMBER OF PAGES</b> 15
	<b>16. PRICE CODE</b>

<b>17. SECURITY CLASSIFICATION OF REPORT</b> Unclassified	<b>18. SECURITY CLASSIFICATION OF THIS PAGE</b> Unclassified	<b>19. SECURITY CLASSIFICATION OF ABSTRACT</b> Unclassified	<b>20. LIMITATION OF ABSTRACT</b> Unlimited
--	---	--	--

FOREWORD

Opinions, interpretations, conclusions and recommendations are those of the author and are not necessarily endorsed by the U.S. Army.

N/A Where copyrighted material is quoted, permission has been obtained to use such material.

N/A Where material from documents designated for limited distribution is quoted, permission has been obtained to use the material.

N/A Citations of commercial organizations and trade names in this report do not constitute an official Department of Army endorsement or approval of the products or services of these organizations.

N/A In conducting research using animals, the investigator(s) adhered to the "Guide for the Care and Use of Laboratory Animals," prepared by the Committee on Care and use of Laboratory Animals of the Institute of Laboratory Resources, national Research Council (NIH Publication No. 86-23, Revised 1985).

X For the protection of human subjects, the investigator(s) adhered to policies of applicable Federal Law 45 CFR 46.

N/A In conducting research utilizing recombinant DNA technology, the investigator(s) adhered to current guidelines promulgated by the National Institutes of Health.

N/A In the conduct of research utilizing recombinant DNA, the investigator(s) adhered to the NIH Guidelines for Research Involving Recombinant DNA Molecules.

N/A In the conduct of research involving hazardous organisms, the investigator(s) adhered to the CDC-NIH Guide for Biosafety in Microbiological and Biomedical Laboratories.



PI - Signature

6/27/03  
Date

## Table of Contents

Cover.....	1
SF 298.....	2
Foreword.....	3
Table of Contents.....	4
Introduction.....	5
Body.....	6
Key Research Accomplishments.....	15
Reportable Outcomes.....	15
Conclusions.....	15
References.....	15
Appendices.....	

# 1. Introduction

Calcifications can be divided into two broad categories. Type I are composed of weddellite (calcium oxalate dihydrate) and whewellite (calcium oxalate monohydrate), while type II calcifications all have some phosphorus content, most typically calcium hydroxyapatite. Type II calcifications are known to be associated with carcinoma, while it is generally accepted that the exclusive finding of type I calcifications is indicative of benign lesions.

We have proposed to develop a technique that will determine the composition of calcifications prior to biopsy, thereby allowing one to avoid biopsy on Type I calcifications. We believe that coherent scatter imaging (which is similar to x-ray diffraction imaging) may best determine the chemical composition of calcifications. In this grant, we propose to design a dedicated detector and optimize image acquisition. We will characterize the detector, and characterize specific raw materials to determine a basis set for compositional analysis. We will validate this design using a clinical trial of surgical biopsy specimens prior to histology. Finally, we propose to design a larger clinical trial designed to answer our main hypothesis, that Type I calcifications are exclusively benign, and hence do not require surgical resection.

This annual report presents our research to date.

## 2. Body

### 2.1. Statement of Work

The work for this grant was divided into six tasks. They are outlined as follows:

#### **TASK 1: COHERENT SCATTER DETECTOR DEVELOPMENT**

- Design and construct the detector
- Modify as needed using data from Tasks 2 and 3

#### **TASK 2: COMPUTER MODELING OF COHERENT SCATTER**

- Generate a monoenergetic model of the coherent scatter from the literature
- Combine to generate a polyenergetic model to study effect of spectrum on scatter
- Add effects of pencil beam size, and finite object size to study effect on scatter
- Develop initial methods of separating data into basis sets
- Add issues related to SNR and dose to optimize detector design and operating conditions

#### **TASK 3: DETECTOR CHARACTERIZATION**

- Characterize the detector in terms of imaging parameters linearity, MTF, NPS, NEQ, and DQE
- Use these data to optimize detector design

#### **TASK 4: PHANTOM STUDIES – BASIS SET DETERMINATION**

- Characterize the detector in terms of basis materials, including linearity.
- Develop a basis set of materials (calcifications, adipose, glandular, etc.)
- Characterize the detector in its ability to distinguish admixtures of materials.
- Develop beam hardening and other corrections as needed to make system accurately report data that are linear in terms of the basis materials.

#### **TASK 5: SPECIMEN STUDY**

- Recruit 100 patients scheduled for surgery on the basis of breast calcifications
- Image the surgical specimens prior to biopsy
- Analyze data and correlate pathology results with compositional analysis

#### **TASK 6: *IN VIVO* IMAGING FEASIBILITY STUDY DESIGN**

- Perform calculations on the feasibility of *in vivo* imaging, including dose.
- Use those data derived in Task 5 to estimate the statistical properties of this test (e.g. Type I calcification prevalence, specificity and sensitivity of composition characterization, etc.)
- Use these data to design larger multi-center clinical trial to definitively determine the correlation between Type I calcifications and benign disease.

## 2.2. Administrative Note

The work in this grant was supposed to commence on July 1, 2000. However, we delayed the start of the research under the belief that the research would commence when the Medical Physics Graduate Program at Thomas Jefferson University was approved and a graduate student hired. However, due to continued delays in the start of the graduate program, we decided in the early summer of 2001 that we could no longer delay work on this grant. Under approval of the DOD, we started of the grant July 1, 2001. Since that time, Dr. Andrew Maidment (PI) and Dr. Michael Albert (Research Associate) have worked on the grant.

Effective February 1<sup>st</sup>, 2003, Dr. Maidment resigned his position at Thomas Jefferson University and began working at the University of Pennsylvania. It is Dr. Maidment's desire and intent to continue this research project at the University of Pennsylvania. Dr. Maidment is in the process of transferring this grant to the University of Pennsylvania. Thomas Jefferson University has already relinquished the grant and returned the unspent funds to the DOD. A one-year no-cost extension will be requested concurrent with the transfer request.

## 2.3. Imaging System Development

At this time, tasks 1 through 4 are substantially complete. An imaging system has been built for performing coherent scatter and small angle x-ray diffraction. The system is shown in Figure 1. The system consists of an x-ray tube, added filtration to shape the x-ray spectrum, a series of collimators, a sample stage, an x-ray image intensifier (XRII) and a CCD camera (not shown). The x-ray tube has a molybdenum target. Typically, the tube is operated in conjunction with 25  $\mu\text{m}$  or 50  $\mu\text{m}$  Niobium added filtration. This serves to eliminate the molybdenum K- $\beta$  radiation, producing an essentially monochromatic x-ray beam at the K- $\alpha$  line of molybdenum (17.4 keV). The collimators serve to form a small spot of radiation that is used to generate the scattered image. We have learned that it is necessary to have 3 collimators in the beam; one to define the x-ray source size, one to collimate the beam to the sample size, and one to clean up small angle scatter from the edges of the 2<sup>nd</sup> collimator. A set of interchangeable x-ray collimators has now been built and tested, and has been incorporated into the test device. The x-ray image intensifier was chosen after initial experiments were performed on a series of test devices. The intensifier has a 4" open diameter, and high spatial resolution. A lead blocker is placed on the front of the image intensifier to prevent the primary x-ray beam from striking the XRII. A new x-ray generator has been included in the imaging system at the University of Pennsylvania. The new x-ray generator/x-ray tube combination allows exposures of up to 49 kVp and 800 mAs. Greater counting statistics can be obtained but averaging multiple images.

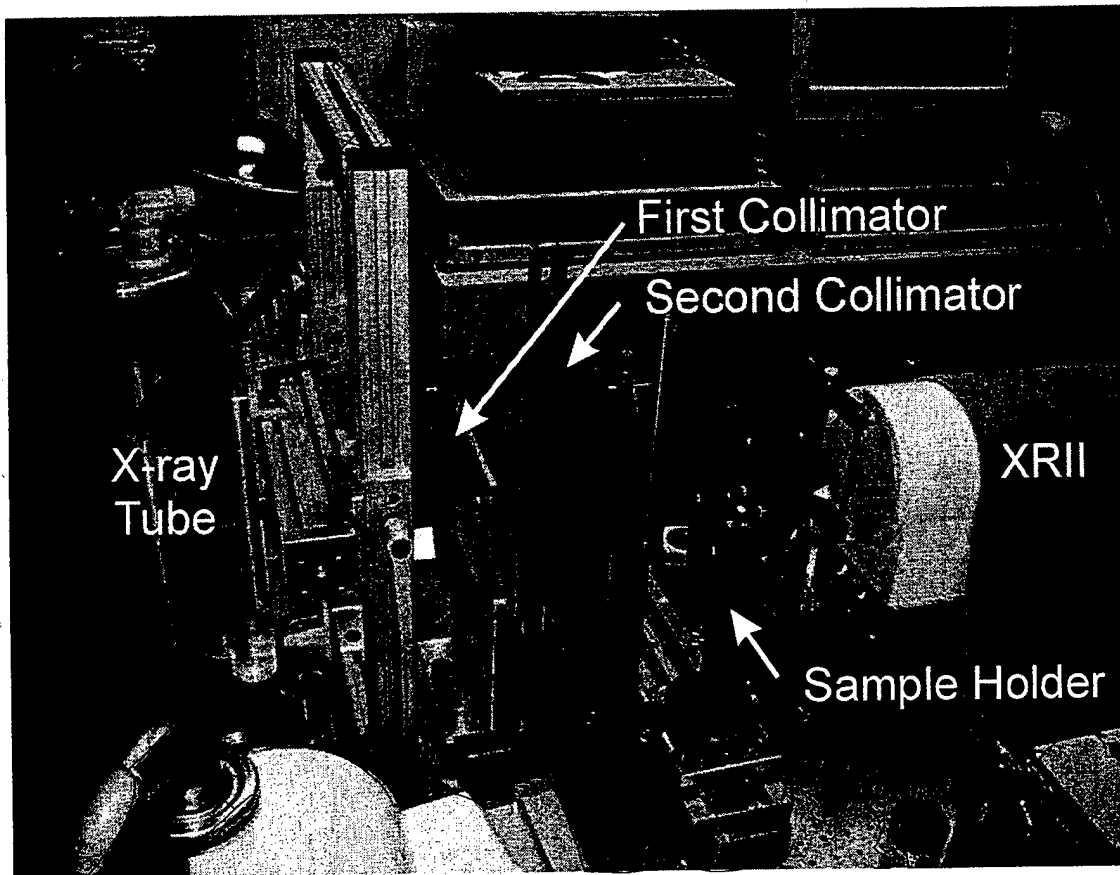
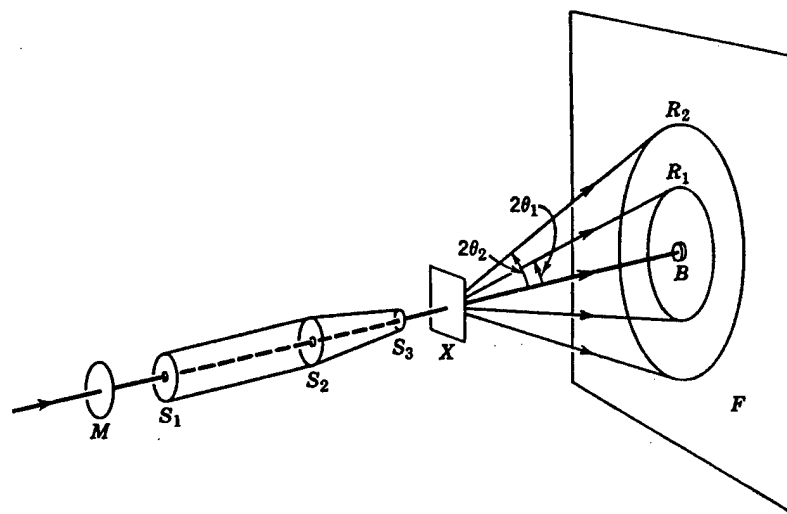

Figure 1: Picture of the imaging system (above). The system consists of an x-ray source, collimators, a sample holder, and an x-ray image intensifier (XRII) and CCD camera. The imaging system is shown in schematic below. The x-ray beam is filtered ( $M$ ) and collimated ( $S_1, S_2, S_3$ ) before being incident on the sample ( $X$ ). The diffracted beam forms rings on the detector ( $F$ ).



## 2.4. Imaging System calibration

Pursuant to Task 4, experiments have been performed to map the spatial domain of the images into diffraction angle ( $2\theta$ , Figure 1 bottom). Diffraction patterns were obtained with an x-ray beam from a molybdenum target x-ray tube operated at 35 kVp with 50  $\mu\text{m}$  niobium filtration to obtain the K- $\alpha$  line. A pinhole collimator is situated 25 cm from the x-ray focus. A second lead sheet, containing an aperture aligned with the pinhole and the x-ray source, is placed 19 cm downstream from the pinhole to remove scatter from the pinhole itself. The material being investigated is placed an additional 17 cm downstream from the lead aperture. The active surface of the image intensifier is 10 cm from the sample being investigated. A small lead cylinder is placed on the face of the image intensifier to block the primary beam. The output of the image intensifier is recorded with a CCD camera using a 75 mm – 50 mm relay lens pair. Images were acquired by running the tube at 35kVp, 75mAs, for either one or three 6-second intervals. When multiple images were acquired, the resultant images were averaged.

Background intensity was measured without any material in the beam. This was used for subtraction from data acquired with materials in place. All acquired data were then plotted as a function of distance on the image intensifier (in terms of pixels) away from the position of the primary beam, as determined without the beam stop. Using these plots, the background was scaled appropriately and then subtracted from the data for each of the materials.

The known positions (described below) of the first rhodium diffraction peaks were used to estimate the geometric factors need to scale distances in pixels into degrees. These data indicated that some effort was required to compensate for geometric distortions, presumably due to the curved surface of the image intensifier and distortions related to the electron optics. These corrections have been designed and applied.

## 2.5. Calcification Investigations

We have tested the imaging system using three types of calcium crystals. Two of the materials, hydroxyapatite and whewellite, were obtained commercially. Weddellite was not commercially available; therefore, we chemically prepared our own weddellite.

We followed two papers on producing weddellite.<sup>1,2</sup> Precipitation is performed in distilled water at a pH of 10. The pH is set using a 0.01N NaOH solution. All chemicals are reagent grade. 1.2 liters of the CaCl<sub>2</sub> solution is prepared at approximately 0.4 molar. To this is added 10 grams of Na<sub>2</sub>C<sub>2</sub>O<sub>4</sub> dissolved in approximately 350 ml of water, again at pH 10. The sodium oxalate solution is added to the calcium chloride solution dropwise. The resulting calcium oxalate precipitates in very fine particles that require about a day to precipitate. We then remove the supernatant liquid, and wash the crystals by resuspending them several times in distilled water.

We have also calculated the diffraction spectra of these materials and compare these calculations to our measurements. The diffraction spectra of all of the materials investigated to date were calculated using Fhkl (Version 1.2 - 1994; <http://www.lmcp.jussieu.fr/sincris/logiciel/Fhkl/>). As input, we have been using data from "webelements" (<http://www.webmineral.com/>), the "MINCRYST" database (<http://database.iem.ac.ru/mincryst>) and the AMS database (<http://www.geo.arizona.edu/AMS>). These spectra were used to calibrate the imaging system using rhodium and molybdenum, and were used to assess this calibration using hydroxyapatite, whewellite and weddellite (2 forms of calcium oxalate).

The source images are shown in Figure 2 and the calculated and derived data are shown in Figures 3-5. The measured spectra show excellent agreement with theoretically predicted values. As can be seen by comparing the spectra of the three materials, each can be distinguished from the other based upon the diffraction spectra. This is the single most important finding we have had to date, as this means that it is very likely that we will be able to distinguish breast calcifications based upon their composition using x-ray diffraction.

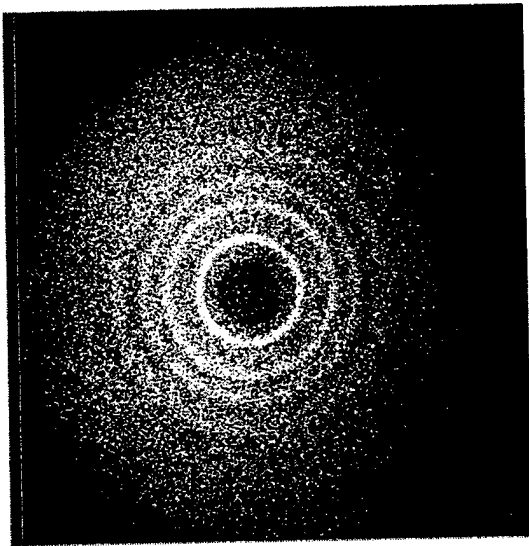

Whewellite

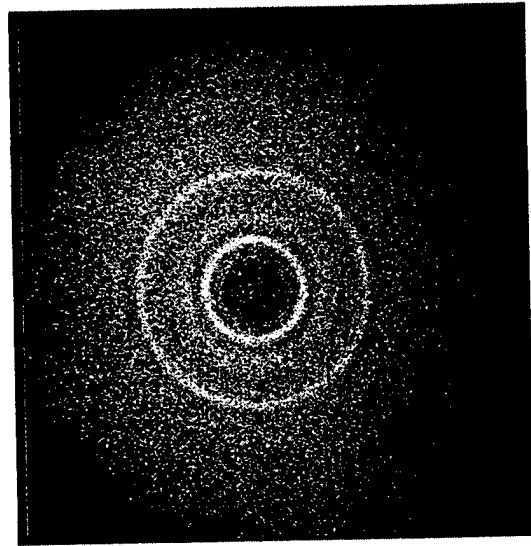

Weddellite

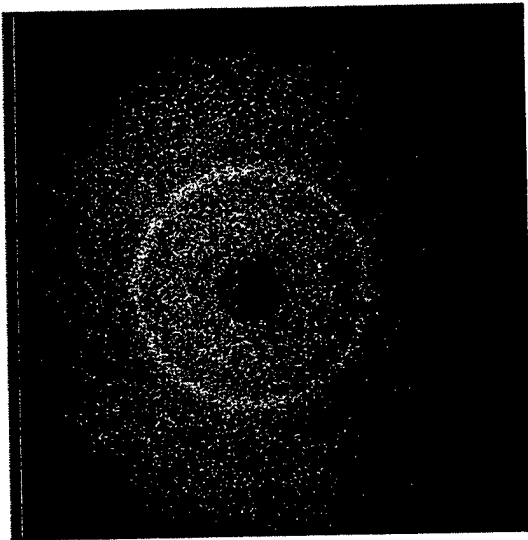

Hydroxyapatite

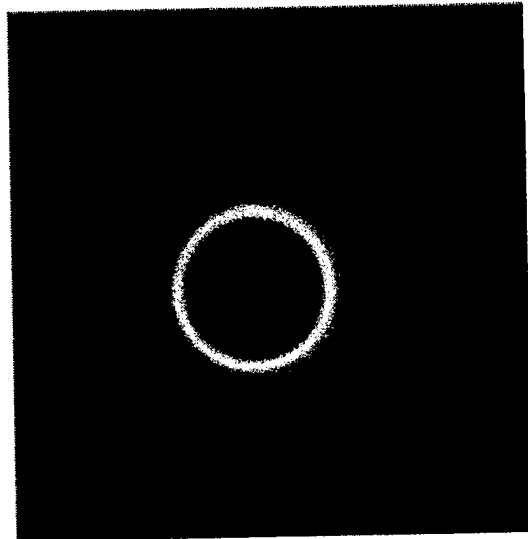

Wax

**Figure 2: Images obtained with the imaging system shown in Figure 1, for a variety of materials, as labeled. The diffraction spectra derived from these images are given in Figures 3-5.**

### Hydroxyapatite

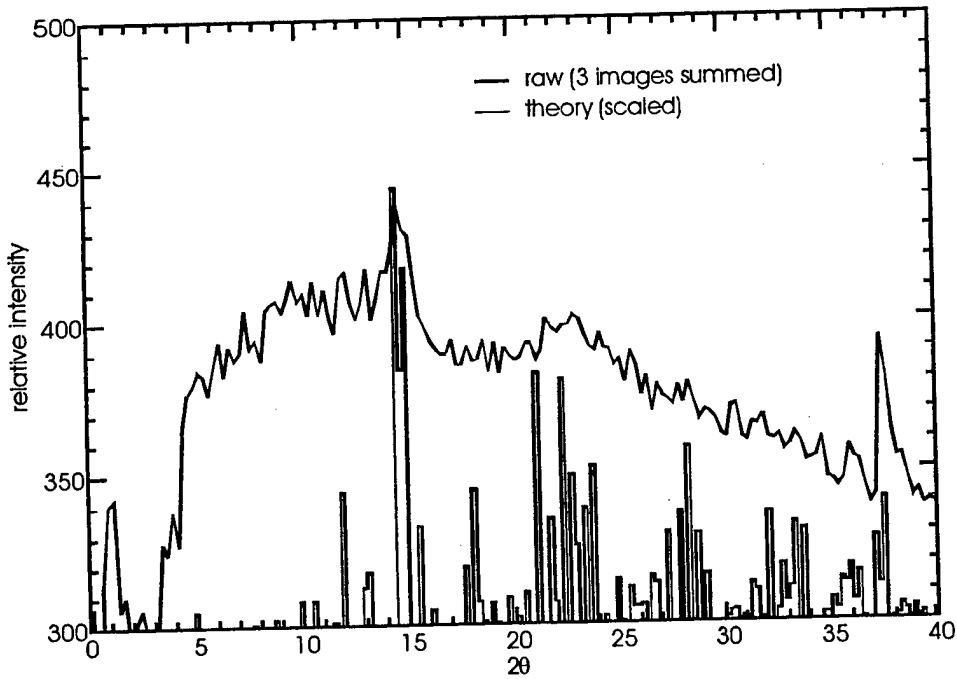

Figure 3: Diffraction spectra of calcium hydroxyapatite

### Whewellite

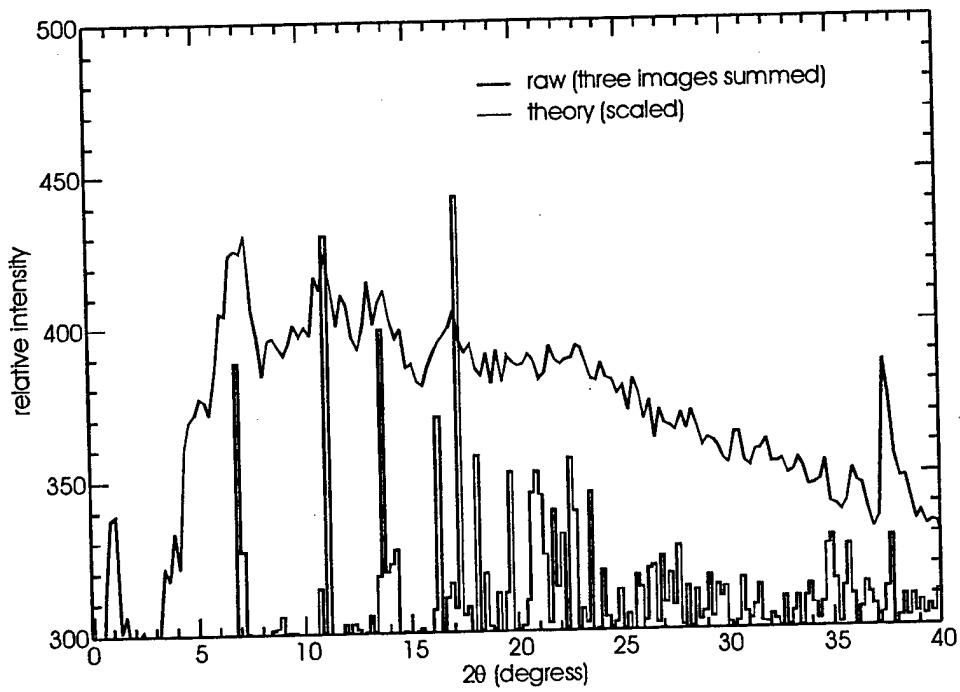

Figure 4: Diffraction spectra of whewellite (calcium oxalate).

## Weddellite precipitate

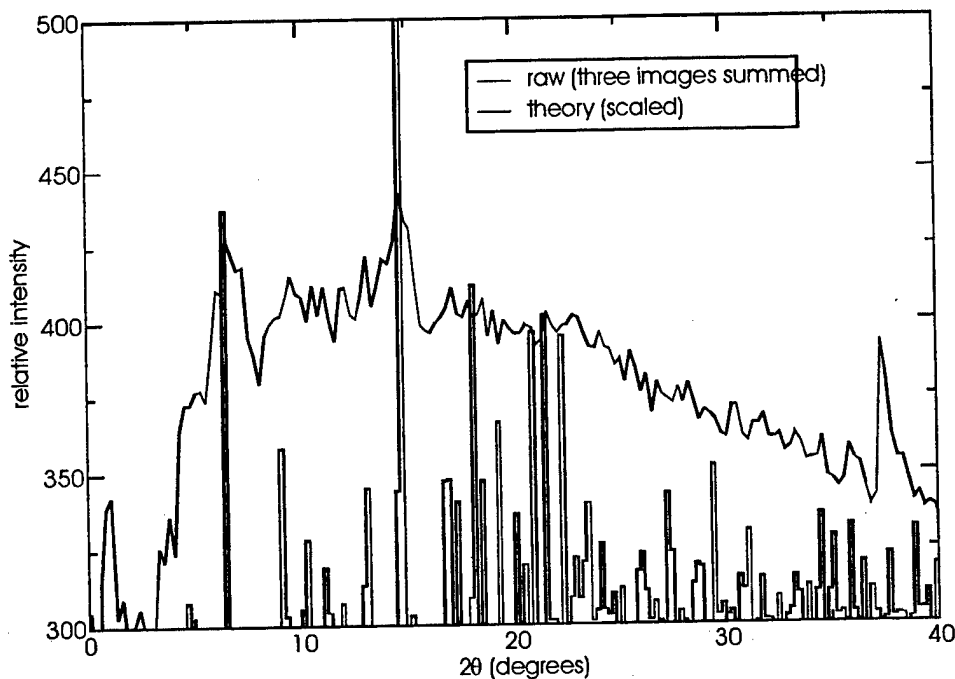
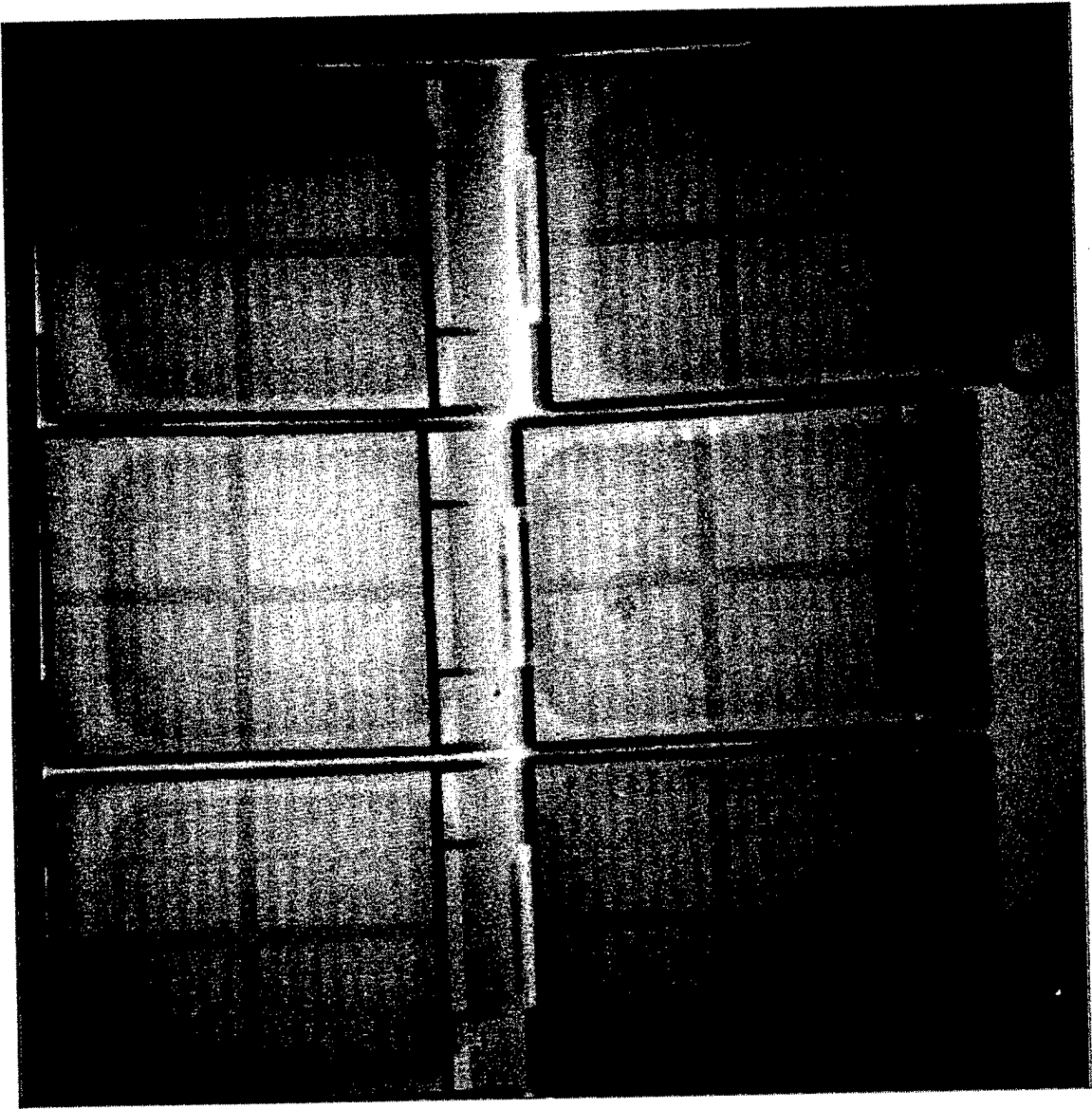

Figure 5: Diffraction spectra of weddellite (calcium oxalate).

### 2.6. Initial Experiments with Breast Specimens

We have tested the imaging system using breast biopsy specimens. These specimens were obtained after IRB review as an exempt study, under expedited review. The specimens were anonymous when provided to us. An example of six such specimens is shown in Figure 6. The specimens are held in a plastic cassette, and set in wax. At this time, we have not been able to measure diffraction spectra from the calcifications in such specimens. This is due, in part, to the fact that the wax is highly scattering. For example if you examine figure 2 (lower right), you will notice that the wax image is much less noisy (there were many more photons scattered into the ring in the image). It is also possible that the process of fixing the tissue has leached the calcified material out of the specimen, and what remains (as seen is the radiograph – Figure 6), is the protein matrix that holds the specimens together.

After the experiments with the samples, we moved the lab to the University of Pennsylvania. We have now established a new collaborative effort with Dr. Carolyn Mais in the Department of Pathology. We are currently in the process of seeking IRB approval to acquire surgically removed breast tissue and evaluate it prior to fixing and setting the specimen in wax.



**Figure 6: Sample radiograph of 6 biopsy specimens, each held in a plastic cassette and set in wax. The middle cassette on the right column shows several large calcifications.**

### **3. Key Research Accomplishments:**

Since the start of the grant, we have assembled a working x-ray diffraction imaging system using the monochromatic-forward technique. We optimized the design of the system, including the detector, collimators and beam stop. We have characterized the detector using known materials, and have begun to experimentally measure the diffraction spectra of calcifications, and compared them to calculated values with considerable agreement. We are currently planning the implementation of the clinical trial of this grant. Pending approval of the grant transfer and IRB approval of the clinical trial, we will acquire clinical cases and complete the grant.

### **4. Reportable Outcomes:**

None to date. We are currently drafting our first paper from this work.

### **5. Conclusions:**

At the conclusion of this, the second, year of experiments, we have successfully been able to measure diffraction spectra of calcified materials, and have shown that the diffraction spectra of calcium hydroxyapatite, whewellite and weddellite are sufficiently different to allow discrimination of the materials by diffraction.

### **6. References:**

- 
- <sup>1</sup> L. W.-Levy and J. Lanipece. Sur la formation des hydrates de l'oxalate de calcium. Comptes Rendus Hebdomadaires Des Seances de L'Academie Des Sciences, 1962, v. 254, p. 296--298.
  - <sup>2</sup> B. Tomazic and G. H. Nancollas. Crystal Growth of Calcium Oxalate Hydrates: A Comparative Kinetics Study, Journal of Colloid and Interface. Science, v. 75, no. 1, 1980, p. 149-160

### **7. Appendices:**

None.