

**FINAL REPORT
OCTOBER 2003**

REPORT NO. 03-11

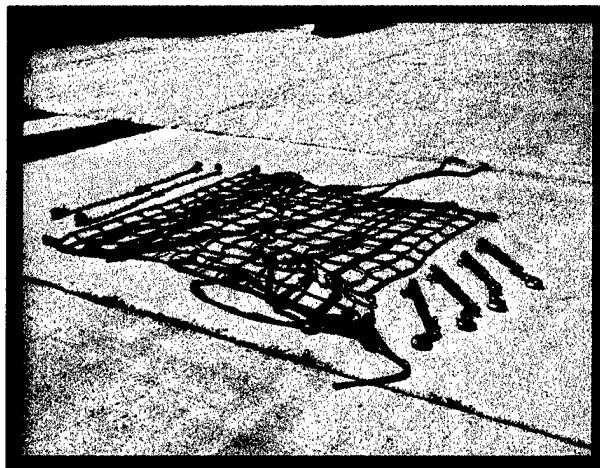

**SMART TIE-DOWN SYSTEM,
TP-94-01, REVISION 1, JULY 2002
"TRANSPORTABILITY TESTING PROCEDURES"**

DISTRIBUTION STATEMENT A
Approved for Public Release
Distribution Unlimited

Prepared for:

Distribution Unlimited:

TACOM/ ARDEC
Logistics Research and Development Activity
ATTN: AMSTA-AR-ASL
Picatinny Arsenal, NJ 07806

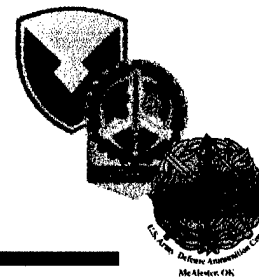

**VALIDATION ENGINEERING DIVISION
MCALESTER, OKLAHOMA 74501-9053**

20031119 062

AVAILABILTY NOTICE

A copy of this report will be furnished each attendee on automatic distribution. Additional copies or authority for reprinting may be obtained by written request from:

Director
U.S. Army Defense Ammunition Center
ATTN: SJMAC-DEV
1 C Tree Road, Bldg. 35
McAlester, OK 74501-9053

Reports may also be downloaded or viewed in PDF format from our web site at:

<http://www/dac.army.mil/DEV/TestReports>

DISTRIBUTION INSTRUCTIONS

Destroy this report when no longer needed. Do not return.

Citation of trade names in this report does not constitute an official endorsement.

The information contained herein will not be used for advertising purposes.

**REPORT NO. 03-11
SMART TIE-DOWN SYSTEM, TP-94-01,
REVISION 1, JULY 2002
"TRANSPORTABILITY TESTING PROCEDURES"**

OCTOBER 2003

ABSTRACT

The U.S. Army Defense Ammunition Center (DAC), Validation Engineering Division (SJMAG-DEV), was tasked by the TACOM/ARDEC, Logistics Research and Development Activity, Picatinny, NJ, to conduct transportability testing using the Smart Tie-Down System manufactured by Creare Incorporated. The test loads consisted of load bays of SCL #23, SCL #2 and C445 wooden boxes. The testing was conducted in accordance with TP-94-01, Revision 1, July 2002 "Transportability Testing Procedures."

The objective of the testing was to evaluate if the Smart Tie-Down System, manufactured by Creare Incorporated, could adequately restrain the load bays when transportability tested in accordance with TP-94-01, Revision 1, July 2002.

Based on the results of testing the Smart Tie-Down System did not adequately restrain the ammunition loads.

Deficiencies in the Smart Tie-Down System include:

1. The load tensioning devices are excessively bulky and exceed the CROP deck width when used with the load bay of SCL #23 which has a width of 87 ¾ inches. This will prohibit loading of the CROP into an intermodal container.
2. The Smart Tie-Down System could not secure the load bay of SCL #2 which has a width of 89 inches. The system could not interface with the tie-down rings on the CROP. The system can only secure payloads up to 85 inches in width without exceeding the CROP deck width and/or interfacing with the tie-down rings.

3. The load tensioning devices backed off during testing and no longer adequately held the net. Auxiliary equipment (wire) was required to prevent the load tensioning devices from backing off.
4. The net stretched which caused the load tensioning devices to loosen and the load to move excessively. The net stretched between initial tensioning and the start of test and during testing.
5. Auxiliary tools are required to tension the system.
6. The load tensioning device components are loose items.
7. There is no limit on the amount of tension that can be applied to the load. Therefore, the payload could easily be damaged when tensioning.
8. The Smart Tie-Down System did not provide adequate load restraint.
9. The net and tensioning device weight is excessive in that a single net and load tensioning devices weigh 119 pounds.
10. The net and load tensioning devices will not stow in the CROP stowage boxes.
11. The net frayed during testing at contact points with the edges of the containers.
12. The net does not interface with the SCL load configurations. As designed the SCL loads would have to be reduced to accommodate the net and tensioning devices.
13. Unable to secure a high load with a single net.
14. Installation of the net and load tensioning devices was difficult and required an excessive amount of time. The installation required that the load tensioning devices be tensioned several times to equalize the tension.

Therefore, the Smart Tie-Down System, as tested, is not satisfactory to transport ammunition.

Prepared by:

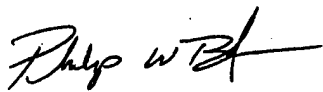

PHILIP W. BARICKMAN
Lead Validation Engineer

Reviewed by:

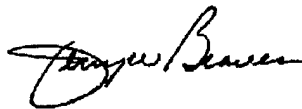

JERRY W. BEAVER
Chief, Validation Engineering Division

U.S. ARMY DEFENSE AMMUNITION CENTER

**VALIDATION ENGINEERING DIVISION
MCALESTER, OK 74501-9053**

REPORT NO. 03-11

**CREARE SMART TIE-DOWN SYSTEM,
TP-94-01, REVISION 1, JULY 2002, "TRANSPORTABILITY TESTING
PROCEDURES"**

TABLE OF CONTENTS

PART	PAGE NO.
1. INTRODUCTION	1-1
A. BACKGROUND.....	1-1
B. AUTHORITY.....	1-1
C. OBJECTIVE	1-1
D. CONCLUSION	1-1
2. ATTENDEES.....	2-1
3. TEST EQUIPMENT.....	3-1
4. TEST PROCEDURES	4-1
A. RAIL TEST	4-1
B. ON/OFF ROAD TESTS.....	4-3
1. HAZARD COURSE	4-3
2. ROAD TRIP	4-4
3. PANIC STOPS.....	4-4
4. WASHBOARD COURSE	4-4
C. SHIPBOARD TRANSPORTATION SIMULATOR (STS).....	4-5
5. TEST RESULTS	5-1
5.1 TESTING DATE –12 AUGUST 2003	5-1
A. RAIL TEST	5-2
B. ON/OFF ROAD TESTS	5-3
1. HAZARD COURSE.....	5-3
2. ROAD TRIP.....	5-4
3. PANIC STOPS.....	5-4
4. HAZARD COURSE	5-4
5. WASHBOARD COURSE.....	5-4
C. SYSTEM TENSION.....	5-6
D. CONCLUSION.....	5-7
5.2 TESTING DATE – NO TEST	5-8

5.3 TESTING DATE –15-25 August 2003	5-9
A. RAIL TEST	5-9
B. ON/OFF ROAD TESTS	5-11
1. HAZARD COURSE	5-11
2. ROAD TRIP	5-12
3. PANIC STOPS	5-12
4. HAZARD COURSE	5-12
5. WASHBOARD COURSE	5-13
C. SHIPBOARD TRANSPORTATION SIMULATOR (STS)	5-13
D. RAIL TEST	5-14
E. SYSTEM TENSION (POUNDS)	5-16
F. CONCLUSION	5-17
6. LOAD CELL DATA	6-1
7. DRAWINGS	7-1

PART 1 – INTRODUCTION

A. BACKGROUND. The U.S. Army Defense Ammunition Center (DAC), Validation Engineering Division (SJMAG-DEV), was tasked by TACOM/ARDEC, Logistics Research and Development Activity, Picatinny, New Jersey, to conduct transportability testing using the Smart Tie-Down System manufactured by Creare Incorporated. The test loads consisted of load bays of SCL #23, SCL #2 and C445 wooden boxes. The testing was conducted in accordance with TP-94-01, Revision 1, July 2002, "Transportability Testing Procedures."

B. AUTHORITY. This test was conducted IAW mission responsibilities delegated by the U.S. Army Joint Munitions Command (JMC), Rock Island, IL. Reference is made to the following:

1. AR 740-1, 15 June 2001, Storage and Supply Activity Operation.
2. OSC-R, 10-23, Mission and Major Functions of U.S. Army Defense Ammunition Center (DAC) 21 Nov 2000.

C. OBJECTIVE. The objective of the testing was to evaluate if the Smart Tie-Down System, manufactured by Creare Incorporated, could adequately restrain the load bays when transportability tested in accordance with TP-94-01, Revision 1, July 2002.

D. CONCLUSION. The Smart Tie-Down System was tested in accordance with TP-94-01, Revision 1, July 2002. Based on the results of testing the Smart Tie-Down System did not adequately restrain the ammunition loads.

Deficiencies in the Smart Tie-Down System include:

1. The load tensioning devices are excessively bulky and exceed the CROP deck width when used with the load bay of SCL #23 which has a width of 87 $\frac{3}{4}$ inches. This will prohibit loading of the CROP into an intermodal container.
2. The Smart Tie-Down System could not secure the load bay of SCL #2 which has a width of 89 inches. The system can only secure payloads up to 85 inches in width without exceeding the CROP deck width. The system could not interface with tie-down rings on the CROP. The system can only secure payloads up to 85 inches in width without exceeding the CROP deck width and/or interfacing with the tie-down rings.
3. The load tensioning devices backed off during testing and no longer adequately held the net. Auxiliary equipment (wire) is required to prevent the load tensioning devices from backing off.
4. The net stretched, which caused the load tensioning devices to loosen and the load to move excessively. The net stretched between initial tensioning and the start of test and during testing.

5. Auxiliary loose tools are required to tension the system.
6. The load tensioning device components are loose items.
7. There is no limit on the amount of tension that can be applied to the load. Therefore, the payload could easily be damaged when tensioning.
8. The Smart Tie-Down System did not provide adequate load restraint.
9. The net and load tensioning device weight is excessive in that a single net and tensioning devices weigh 119 pounds.
10. The net and load tensioning devices will not stow in the CROP stowage boxes.
11. The net frayed during testing at contact points with the edges of the containers.
12. The net does not interface with the SCL load configurations. As designed, the SCL loads would have to be reduced to accommodate the net and tensioning devices.

13. Unable to secure a high load with a single net.
14. Installation of the net and load tensioning devices was difficult and required an excessive amount of time. The installation required that the load tensioning devices be tensioned several times to equalize the tension.

Therefore, the Smart Tie-Down System, as tested, is not satisfactory to transport ammunition.

PART 2 - ATTENDEES

ATTENDEE

MAILING ADDRESS

Philip Barickman
DSN 956-8992
(918) 420-8992

Director
U.S. Army Defense Ammunition Center
ATTN: SJMAC-DEV
1 C Tree Road, Bldg. 35
McAlester, OK 74501-9053

Nelson Gravenstede
DSN 880-2115
(973) 724-2115

TACOM/ARDEC Logistics R&D Activity
Advanced Systems Concept Office
AMSTA-AR-ASL
Picatinny, NJ 07806-5000

James Kisner
DSN 746-1773
(256) 876-1773

U.S. Army Ordnance Missile &
Munitions Center and School
ATTN: ATSK-CMT-Z
Redstone Arsenal, AL 35897-6095

David Hale
DSN 687-0579
(804) 734-0579

Combined Armed Services Command
DCD – Ordnance
3901 A Avenue, Suite 250
Fort Lee, VA 23801

Major Sabrina Francis
DSN 687-0002
(804) 734-0002

Combined Armed Services Command
DCD – Ordnance
3901 A Avenue, Suite 250
Fort Lee, VA 23801

Peter Burghardt
(603) 643-3800, ext. 2365

Creare Incorporated
16 Great Hollow Road
P.O. Box 71
Hanover, NH 03755

William Baschnagel
(603) 640-2411

Creare Incorporated
16 Great Hollow Road
P.O. Box 71
Hanover, NH 03755

PART 3 - TEST EQUIPMENT

1. Smart Tie Down System
Manufactured by Creare Incorporated, Hanover, NH

2. Truck, Tractor
5 Ton, 6 X 6
Model #: XM818 with winch
Manufactured by General Products Division, Jeep Corporation
ID #: 05A-74971-C124-13529
Weight: 20,955 pounds

3. Semitrailer, flatbed, breakbulk/container transporter, 22.5 ton
Model #: M871
Manufactured by Southwest Truck Body, St. Louis, MO
ID #: NX03PJ – 0063
NSN: 2330 00 122 6799
Weight: 15,630 pounds

4. Semitrailer, flatbed, breakbulk/container transporter, 22.5 ton
Model #: M872A1
Manufactured by Heller Truck Body Corporation, Hillsdale, NJ
ID #: 11-1505 NX05NZ
NSN: 2330 01 109 8006
Weight: 19,240 pounds

5. Intermodal Container
ID # CMCU 200006-8
Date of Manufacture: 06/99
Manufactured by Charleston Marine Containers, Charleston, SC
Tare Weight: 4870 pounds
Maximum Gross Weight: 67,200 pounds

6. Container Roll in/out Platform

Model Number: M3

Serial Number: 0007

Manufactured by Summa Technologies Incorporated

NSN: 3990 01 442 2751

Tare Weight: 3650 Pounds

7. Container Roll in/out Platform

Model Number: M3A1

Serial Number: Yuma 18 122

Manufactured by Hyundai Precision America

Tare Weight: 4000 Pounds

PART 4 - TEST PROCEDURES

The test procedures outlined in this section were extracted from TP-94-01, "Transportability Testing Procedures," July 1994, for validating tactical vehicles and outloading procedures used for shipping munitions by tactical or commercial truck, railcar, and ocean-going vessel.

Inert (non-explosive) items will be used to build the load. The test loads will be prepared using the blocking and bracing procedures proposed for use with munitions (**see Part 7 for procedures**). The weight and physical characteristics (weights, physical dimensions, center of gravity, etc.) of the test loads will be similar to live (explosive) ammunition.

A. RAIL TEST. RAIL IMPACT TEST METHOD. The test load or vehicle will be secured to a flatcar. The equipment needed to perform the test will include the specimen (hammer) car, four empty railroad cars connected together to serve as the anvil, and a railroad locomotive. The anvil cars will be positioned on a level section of track with air and hand brakes set and with draft gears compressed. The locomotive unit will push the specimen car toward the anvil at a predetermined speed, then disconnect from the specimen car approximately 50 yards away from the anvil cars allowing the specimen car to roll freely along the track until it strikes the anvil. This will constitute an impact. Impacting will be accomplished at speeds of 4, 6, and 8.1 mph in one direction and at a speed of 8.1 mph in the reverse direction. The speeds will have a tolerance of plus .5 mph and minus zero mph. The impact speeds will be determined by using an electronic counter to measure the time for the specimen car to traverse an 11-foot distance immediately prior to contact with the anvil cars (see Figure 1).

ASSOCIATION OF AMERICAN RAILROADS (AAR)

STANDARD TEST PLAN

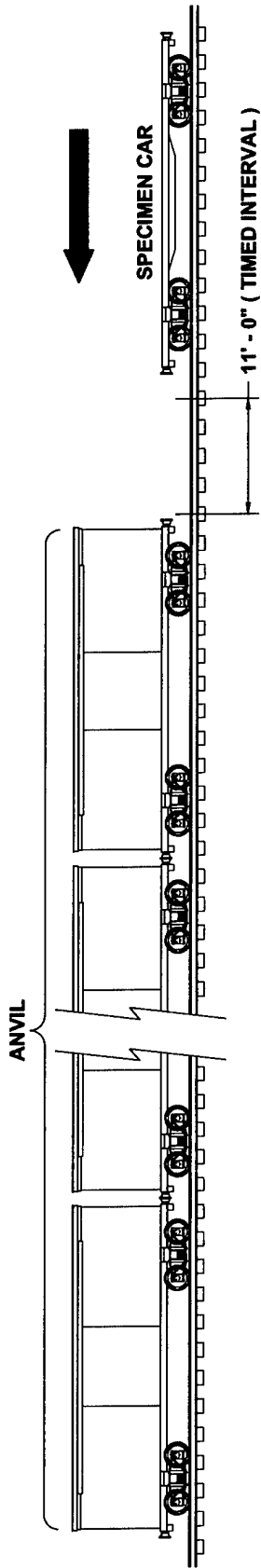

SPECIMEN CAR IS RELEASED BY SWITCH ENGINE TO ATTAIN:

- IMPACT NO. 1 @ 4 MPH**
- IMPACT NO. 2 @ 6 MPH**
- IMPACT NO. 3 @ 8.1 MPH**

THEN THE CAR IS REVERSED AND RELEASED BY SWITCH ENGINE TO ATTAIN:

- IMPACT NO. 4 @ 8.1 MPH**

4 BUFFER CARS (ANVIL) WITH DRAFT GEAR COMPRESSED AND AIR BRAKES IN A SET POSITION

ANVIL CAR TOTAL WT. 250,000 LBS (APPROX)

Figure 1. Rail Impact Sketch

B. ON/OFF ROAD TESTS.

1. **HAZARD COURSE**. The test load or vehicle will be transported over the 200-foot-long segment of concrete-paved road consisting of two series of railroad ties projecting 6 inches above the level of the road surface. The hazard course will be traversed two times (see Figure 2).

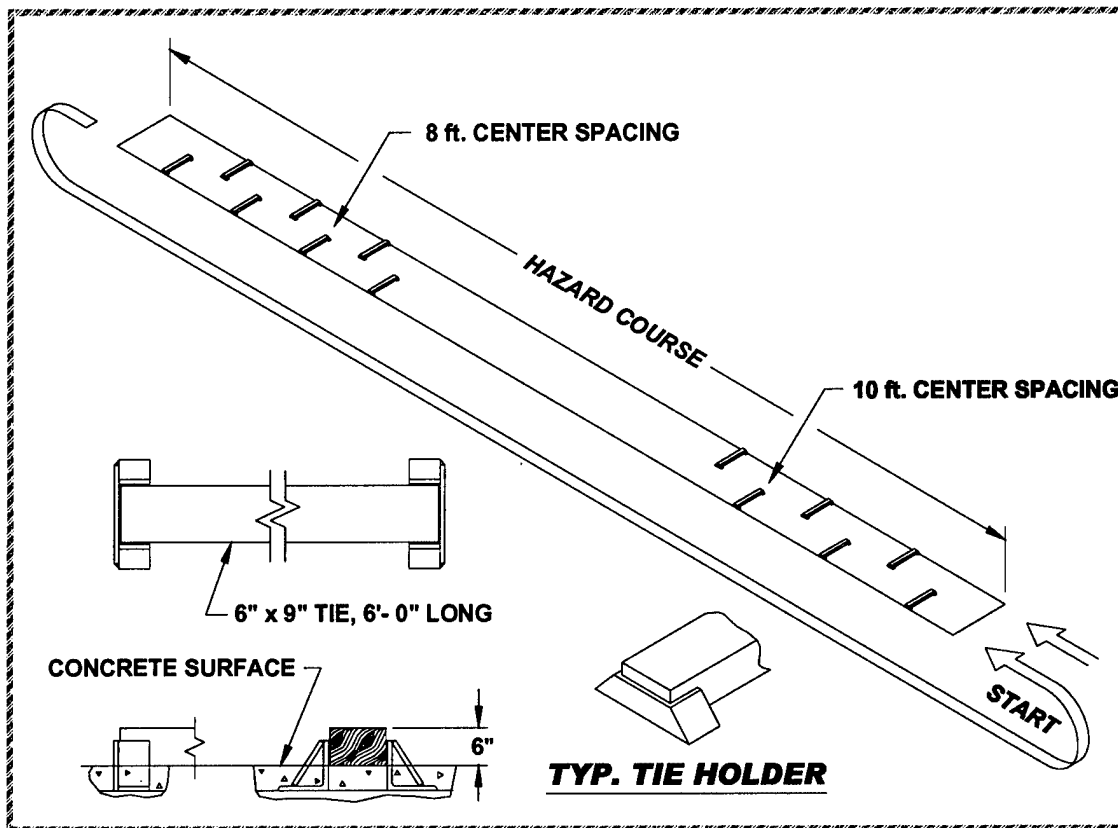

Figure 2. Hazard Course Sketch

- a. The first series of 6 ties are spaced on 10-foot centers and alternately positioned on opposite sides of the road centerline for a distance of 50 feet.
- b. Following the first series of ties, a paved roadway of 75 feet separates the first and second series of railroad ties.
- c. The second series of 7 ties are spaced on 8-foot centers and alternately positioned on opposite sides of the road centerline for a distance of 50 feet.

d. The test load is driven across the hazard course at speeds that will produce the most violent vertical and side-to-side rolling reaction obtainable in traversing the hazard course (approximately 5 mph).

2. **ROAD TRIP**. The test load or vehicle will be transported for a distance of 30 miles over a combination of roads surfaced with gravel, concrete, and asphalt. The test route will include curves, corners, railroad crossings and stops and starts. The test load or vehicle will travel at the maximum speed for the particular road being traversed, except as limited by legal restrictions.

3. **PANIC STOPS**. During the road trip, the test load or vehicle will be subjected to three (3) full airbrake stops while traveling in the forward direction and one in the reverse direction while traveling down a 7 percent grade. The first three stops are at 5, 10, and 15 mph while the stop in the reverse direction is approximately 5 mph. This testing will not be required if the Rail Impact Test is performed.

4. **WASHBOARD COURSE**. The test load or vehicle will be driven over the washboard course at a speed that produces the most violent response in the vertical direction.

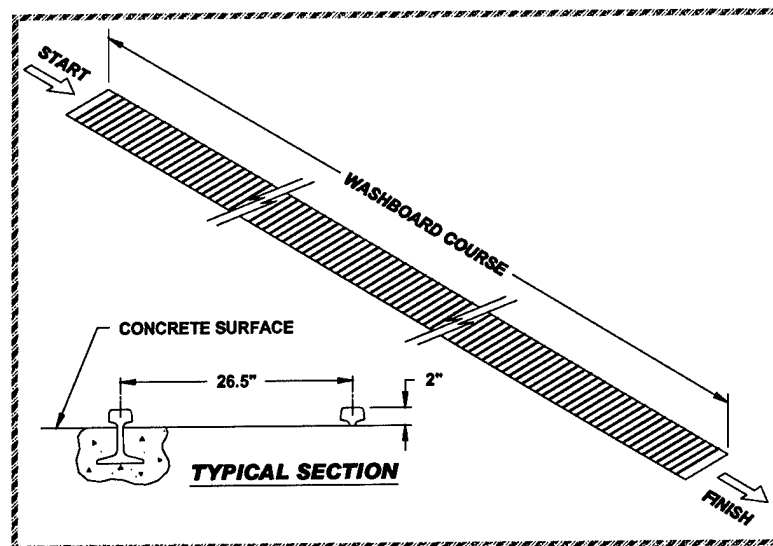

Figure 3. Washboard Course Sketch

C. OCEAN-GOING VESSEL TEST. SHIPBOARD TRANSPORTATION

SIMULATOR (STS) TEST METHOD. The test load will be secured inside an ISO container and will be positioned onto the STS and securely locked in place using the cam locks at each corner. Oscillation of the STS will be started and rotate to an angle of 30 degrees plus or minus 2 degrees, either side of center and at a frequency of 2 cycles-per-minute (30 seconds, plus or minus 2 seconds total roll period). This frequency will be observed for apparent defects that could cause a safety hazard. The frequency of oscillation will then be increased to 4 cycles-per-minute (15 seconds, plus or minus 1 second per roll period) and the apparatus operated a period of two (2) hours. An inspection of the load will then be conducted. If the inspection does not indicate an impending failure, the frequency of oscillation will be further increased to 5 cycles-per-minute (12 seconds, plus or minus 1 second-cycle time), and the apparatus operated for four (4) hours. The operation does not necessarily have to be continuous, however, no change or adjustments to the load or load restraints will be permitted at any time during the test. After once being set in place, the test load (specimen) will not be removed from the apparatus until the test has been completed or is terminated.

PART 5 - TEST RESULTS

5.1

Payload: Load Bay of SCL #23 on a Hyundai CROP.

The load bay consisted of 12 pallets of D563 155MM Projectiles and 2 light pallet units of D541 155MM Prop Charges.

Remarks: The load bay with the net and the load tensioning devices exceeded the overall width of the CROP. Therefore, the CROP could not be inserted into an intermodal container.

Testing Date: 12 August 2003

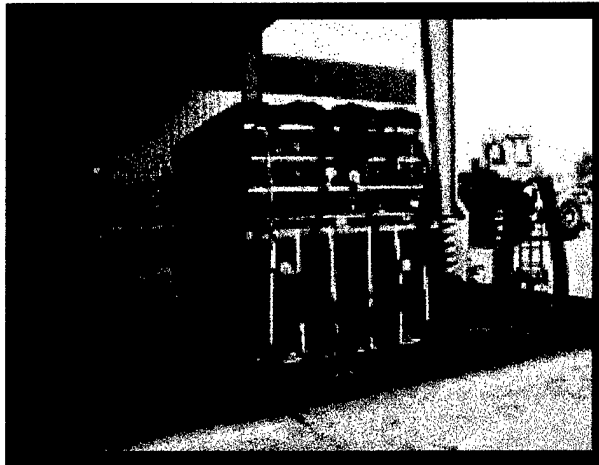

Photo 1. SCL #23 Load Bay with Smart Tie-Down System.

A. RAIL TEST.

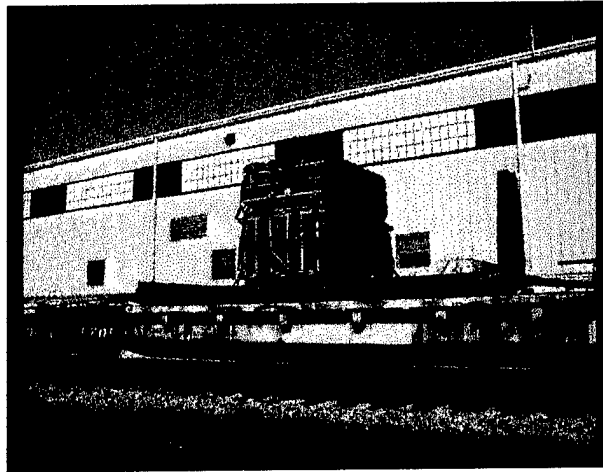

Photo 2. Rail Impact Testing of Smart Tie-Down with SCL #23 Load Bay.

Description	Weight
Flatcar Number: OTTX 97099	68,100 lbs.
CROP with Load Bay of SCL #23	16,555 lbs.
Total Specimen Wt.	84,655 lbs.
Buffer Car (four cars)	257,900 lbs.

Figure 4.

Remarks: Figure 4 lists the test components and weights of the items used during the Rail Impact Tests.

Impact Number	Avg. Velocity (mph)
1	3.5
2	4.5
3	6.3
4	8.1
5	8.2

Figure 5.

Remarks:

1. Figure 5 lists the average speeds of the specimen car immediately prior to impact with the anvil. Impact #1 was determined to be a “no test” due to the inadequate impact speed (minimum 4 mph). Impact #5 is the reverse impact.
2. Following Impact #3 the payload moved 0.13 inches in the direction of impact.
3. Following Impact #4 the center base pallets of 155MM Projectiles moved in the direction of impact 1 inch. The outside pallets of 155MM Projectiles moved 0.25-0.5 inches in the direction of impact.
4. Following Impact #5 the center base pallets of 155MM Projectiles moved 3.75 inches in the direction of impact. The outside pallets of 155MM Projectiles moved 1.25-2.5 inches in the direction of impact.

B. ON/OFF ROAD TESTS.

1. HAZARD COURSE.



Photo 3. Hazard Course Testing of the Smart Tie-Down System with SCL #23 Load Bay

Pass No.	Elapsed Time	Avg. Velocity (mph)
1	25 Seconds	5.9
2	26 Seconds	5.7

Figure 6.

Remarks:

1. Figure 6 lists the average speeds of the test load through the Hazard Course.
2. Inspection following Pass #1 revealed that the 155MM Projectile load had moved 0.38 inches toward the passenger side.
3. Inspection following Pass #2 revealed that the 155MM Projectile load had moved an additional 0.38 inches toward the passenger side. The 155MM Projectile load had also moved toward the cab 0.75 inches.

2. ROAD TRIP:

Remarks:

1. The Road Trip was conducted following the Road Hazard Course Pass #2.
2. Following completion of the Road Trip inspection revealed the top pallets (Prop Charges) moved toward the rear of the trailer 0.75-1.25 inches and toward the driver's side 1 inch. The Projectile pallets moved toward the driver's side 1.75-2.75 inches during the Road Trip. The load tensioning devices backed off during testing.
3. The testing was stopped due to the Smart Tie-Down System was no longer performing adequately.

3. PANIC STOPS: Testing was not required since the Smart Tie-Down System was rail impact tested.

4. HAZARD COURSE: Passes #3 & #4 were not conducted due to the Smart Tie-Down System was no longer performing adequately.

5. WASHBOARD COURSE:

Remarks:

1. The Smart Tie-Down System was retensioned prior to the start of the Washboard Course.
2. The load tensioning devices backed off 1.0-3.25 inches during the test and were no longer providing proper tension to the net.

3. The 155MM Projectile pallets moved 2-6 inches toward the passenger side of the trailer and an additional 0.75 inches toward the cab during testing.
4. The top pallets (Prop Charges) moved 1.5-2.0 inches toward the passenger side.
5. Inspection following the completion of the Washboard Course revealed that the payload overhung the side of the CROP.

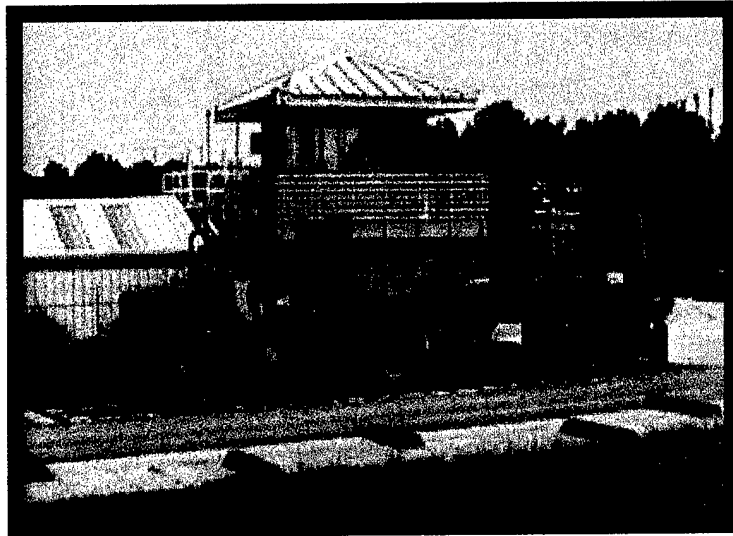

Photo 4. Washboard Course Testing of Smart Tie-Down System with SCL #23 Load Bay.

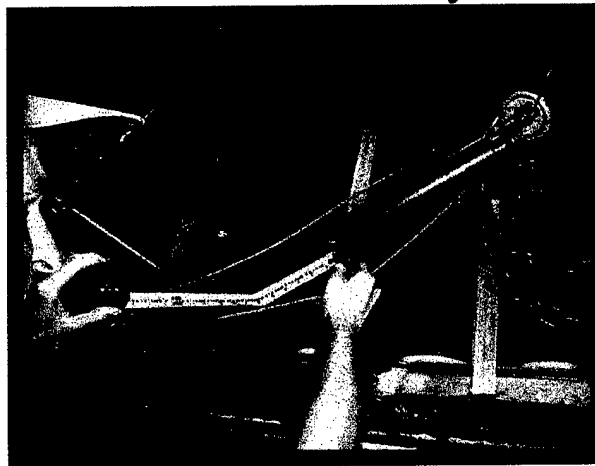

Photo 5. Backing off of Load Tensioning Devices.



Photo 6. Payload Overhanging the Edge of the CROP

C. SYSTEM TENSION (POUNDS).

Load Cell	#4	#5	#6	#7
Start of Rail Impact	1377	961	1064	808
Completion of Rail Impact	607	467	644	674
Start of Washboard Course (retensioned)	1377	1805	378	472
Completion of Washboard Course	5	0	9	24

Figure 7

Figure 7 lists the load cell data throughout the testing. As shown by the data, the net stretched or the binders backed off during testing. This enabled the load to move excessively during testing. The load cells were initially preloaded to approximately 2,500 lbs. at the conclusion of the loading. During the period between the loading and the initiation of the testing, the netting stretched resulting in a decrease of preload. The maximum tension experienced during testing was 5,380 lbs. for the 8.1 mph (actual 8.1 mph) Rail Impact. However,

this may not be representative of actual events due to the fact that the net stretched and the load binders backed off during testing.

D. CONCLUSION:

1. The Smart Tie-Down System did not adequately restrain the ammunition load during testing and the payload moved excessively during testing.

2. A single Smart Tie-Down System net could not be used to secure the load bay. Two nets were used to secure the SCL #23 load bay.

3. The load bay with the net and the load tensioning devices of the Smart Tie-Down System exceeded the deck width of the CROP. Therefore the CROP could not be inserted and tested inside an intermodal container.

4. During testing the load tensioning devices backed off and no longer adequately held the net secure.

5. The net stretched which caused the load tensioning devices to loosen and the load to move excessively. The net stretched between initial tensioning, start of test and during testing.

6. Auxiliary loose tools are required to tension the system.

7. The load tensioning devices are loose items.

8. There is no limit on the amount of tension that can be applied to the load. Therefore, the payload could easily be damaged when tensioning.

9. The net frayed during testing at contact points with the edges of the containers.

10. Installation of the net and tensioning devices was difficult and required an excessive amount of time. The installation required that the load tensioning devices be tensioned several times to equalize the tension.

5.2

Payload: Load Bay of SCL #2 on Summa CROP

The load bay consisted of 4 pallets of C792 120MM Prop Charges and a Light G815/G826 Pallet Unit.

Remark: Testing of this load was not conducted. The Smart Tie-Down System could not secure an 89-inch payload and interface with the tie-down rings on the CROP. The loading and securement were not attempted.

CONCLUSION: The Smart Tie-Down System does not interface with all SCL configurations.

5.3

Payload: Load bay of two pallets of C445 wooden boxes.

Remark: This load was assembled especially for the Smart Tie-Down System and the C445 pallets were not oriented in the traditional pinwheel pattern. Additionally the load tensioning devices were wired to prevent backing off during the test.

Testing Date: 15-25 August 2003



Photo 8. Smart Tie-Down System with Load Bays of C445 Wooden Boxes.

A. RAIL TEST.



Photo 9. Rail Impact Testing of Smart Tie-Down System with C445 Load Bay.

Description	Weight
Flatcar Number: OTTX 97099	68,100 lbs.
CROP with Load Bay of C445	9785 lbs.
Total Specimen Wt.	77,885 lbs.
Buffer Car (four cars)	257,900 lbs.

Figure 8.

Remarks: Figure 8 lists the test components and weights of the items used during the Rail Impact tests.

Impact Number	Avg. Velocity (mph)
1	3.5
2	3.5
3	4.5
4	5.7
5	6.1
6	7.0
7	7.7
8	8.5
9	9.1

Figure 9.

Remarks:

- Figure 9 lists the average speeds of the specimen car immediately prior to impact with the anvil. Impact #1, #2, #4, #6 and #7 were determined to be a "no test" due to the inadequate impact speed. Impact #9 is the reverse impact.
- Inspection following Impact #5 revealed that one load binder had backed off 0.13 inches.

3. Following Impact #8 the payload moved 0.25 inches in the direction of impact and 0.5 inches toward the passenger side.
4. Following Impact #9 the second binder on the passenger side loosened 0.13 inches. The payload moved 1.5-2.0 inches in the direction of impact.

B. ON/OFF ROAD TESTS.

1. HAZARD COURSE.



Photo 10. Hazard Course Testing of the Smart Tie-Down System with C445 Load Bay

Pass No.	Elapsed Time	Avg. Velocity (mph)
1	26 Seconds	5.9
2	26 Seconds	5.9

Figure 10

Remarks:

1. Figure 10 lists the average speeds of the test load through the Hazard Course.
2. Inspection following Pass #1 revealed that the payload had moved 1.5-2.5 inches toward the passenger side.
3. Inspection following Pass #2 revealed that the payload had moved an additional 1.5-1.75 inches toward the passenger side.

2. ROAD TRIP:

Remarks:

1. The Road Trip was conducted following the Road Hazard Course Pass #2.
2. Following completion of the Road Trip inspection revealed that the payload moved an additional 0.25-1.0 inches toward the passenger side. The passenger side pallet also move 0.75 inches toward the rear of the trailer and the driver side pallet moved 0.25 inches toward the front of the trailer.

3. PANIC STOPS: Testing was not required since the Smart Tie-Down System was rail impact tested.

4. HAZARD COURSE:

Pass No.	Elapsed Time	Avg. Velocity (mph)
3	24 Seconds	6.4
4	25 Seconds	6.1

Figure 11

Remarks:

1. Figure 11 lists the average speeds of the test load through the Hazard Course.
2. Passes #3 & #4 were conducted following completion of the Road Trip.
3. Inspection following Pass #3 revealed that the load had moved an additional 0.25 inches toward the passenger side. The passenger side pallet moved an additional 0.25 inches toward the rear of the trailer and the driver side an additional 0.25 inches toward the front of the trailer.
4. Inspection following Pass #4 revealed that the payload moved toward the driver side 0.25-1.0 inches. The passenger side pallet moved an additional 0.25 inches toward the rear of the trailer and the driver side an additional 0.25 inches toward the front of the trailer.

5. WASHBOARD COURSE:

Remarks:

1. The load moved an additional 2.25 inches toward the passenger side.
2. The load tensioning system was outside the external dimensions of the CROP.

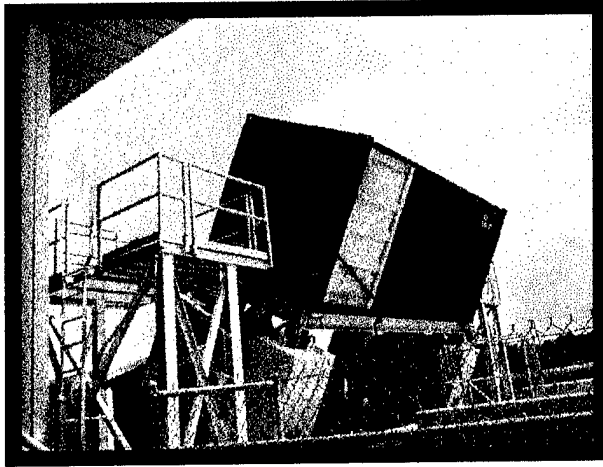

Photo 11. Washboard Course Testing of Smart Tie-Down System with C445 Load Bay.

C. SHIPBOARD TRANSPORTATION SIMULATOR (STS).

Remarks:

1. The payload and the Smart Tie-Down System were repositioned and retensioned prior to the start of the STS. Therefore, the results of the test are not representative.
2. The CROP and payload were then inserted into an intermodal container.
3. No significant movement occurred with the payload during the STS Testing.



**Photo 12. STS Testing of Smart Tie-Down System
with C445 Load Bay**

D. RAIL TEST.



Photo 13. Rail Impact Testing of Smart Tie-Down with C445 Load Bay.

Description	Weight
Flatcar Number: DODX 48,797	62,700 lbs.
CROP with Load Bay of C445 inside an Intermodal end opening container	14,655 lbs.
M1 Flatrack with MLRS Pods	28,265 lbs.
Total Specimen Wt.	105,620 lbs.
Buffer Car (four cars)	257,900 lbs.

Figure 12.

Remarks:

1. Figure 12 lists the test components and weights of the items used during the Rail Impact Tests.
2. The Smart Tie-Down System was retensioned and the CROP with payload was inserted into an intermodal container for rail impact.

Impact Number	Avg. Velocity (mph)
1	4.2
2	6.3
3	8.3
4	8.4

Figure 13.

Remarks:

1. Figure 13 lists the average speeds of the specimen car immediately prior to impact with the anvil. Impact #4 is the reverse impact.
2. Following Impact #4 the payload moved 0.13-0.5 inches in the direction of impact.
3. Each pallet moved toward the center 0.25 inches.

E. SYSTEM TENSION (POUNDS):

Load Cell	#4	#5	#6	#7
Initial	2529	2355	2207	2220
Start of Rail Impact #3	1041	984	859	862
Completion of Rail Impact	42	5	653	686
Start of Hazard Course Pass #2	135	261	42	15
Completion of Hazard Course Pass #4	103	126	37	54
Prior to STS (Retensioned)	2785	2458	2440	2540
Start of STS	1035	821	756	838
End of STS	612	373	397	399
Prior to Rail Impact in Intermodal Container (Retensioned)	2100	2123	2048	2351
Start of Rail Impact	1260	1171	1227	1349
Completion of Rail Impact	1470	1148	588	545

Figure 14

Figure 14 lists the load cell data throughout the testing. As shown by the data, the net stretched throughout testing. This enabled the load to move excessively during testing. The maximum tension experienced during testing was 6,664 lbs. for the 8.1 mph (actual 8.4 mph) Reverse Rail Impact.

However, this may not be representative of actual events due to the fact that the net stretched during testing.

F. CONCLUSION:

1. The Smart Tie-Down System did not adequately restrain the ammunition load during testing.

2. The net does not interface with the SCL load configurations. As designed the SCL loads would have to be reduced to accommodate the net and load tensioning devices.

3. The net stretched which caused the load tensioning devices to loosen and the load to move excessively. The net stretched between initial tensioning, start of test and during testing.

4. Auxiliary loose tools are required to tension the system.

5. The load tensioning devices are loose items.

6. There is no limit on the amount of tension that can be applied to the load. Therefore, the payload could easily be damaged when tensioning.

7. Installation of the net and tensioning devices was difficult and required an excessive amount of time. The installation required that the load tensioning devices be tensioned several times to equalize the tension.

PART 6 – LOAD CELL DATA

The load cells were located on the test specimen as shown below. The load cell readings are described on each of the following graphic depictions of each of the railcar impacts, hazard course, road course, and washboard course.

SMART TIE-DOWN SYSTEM			
SCL 23 LOAD BAY	PAGE	C445 LOAD BAY	PAGE
Rail Impact	6-3	Rail Impact	6-17
Hazard Course	No Data	Hazard Course – Passes #2 - 4 Pass #1 - No Data	6-35
Washboard Course	6-12	Washboard Course	No Data
		Rail Impact in Intermodal Container	6-41

SCL 23 LOAD BAY SENSOR LOCATION

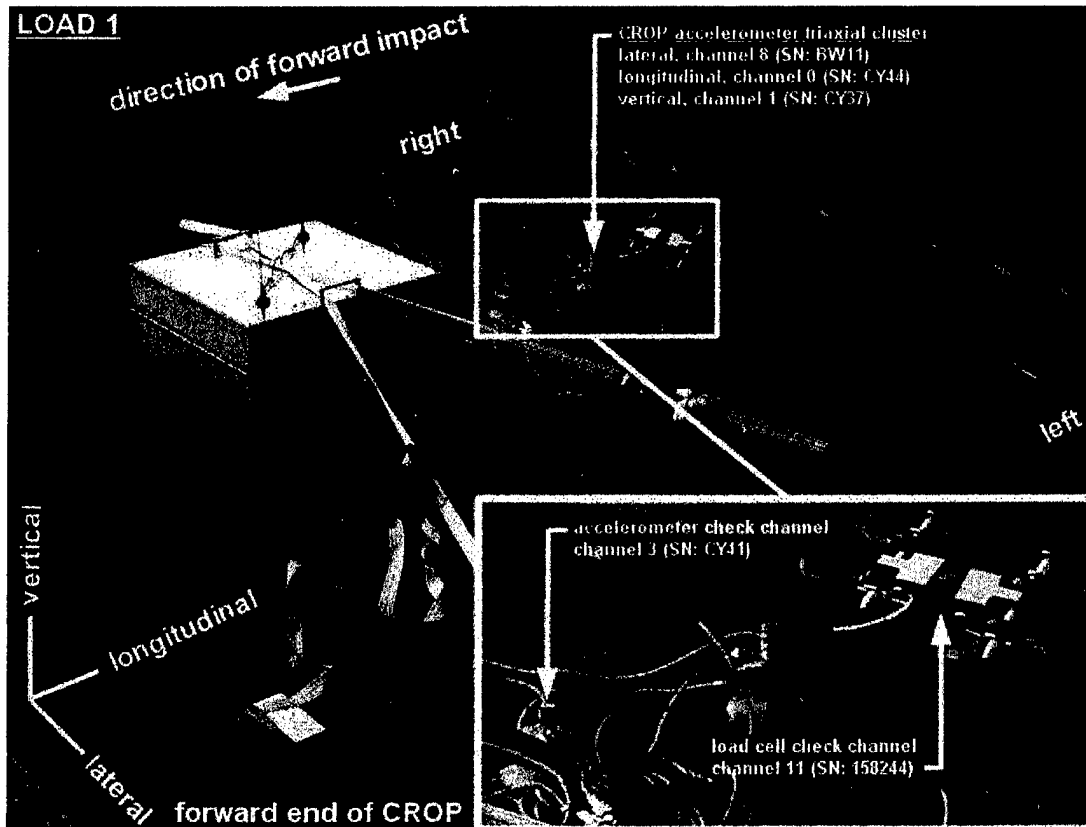

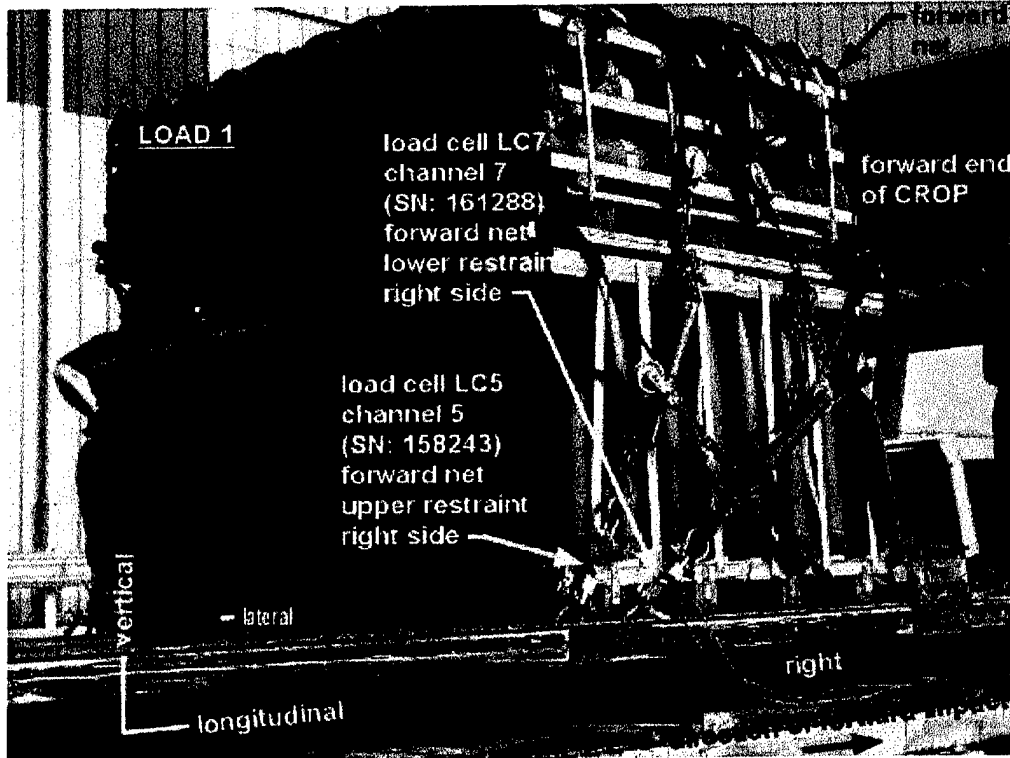
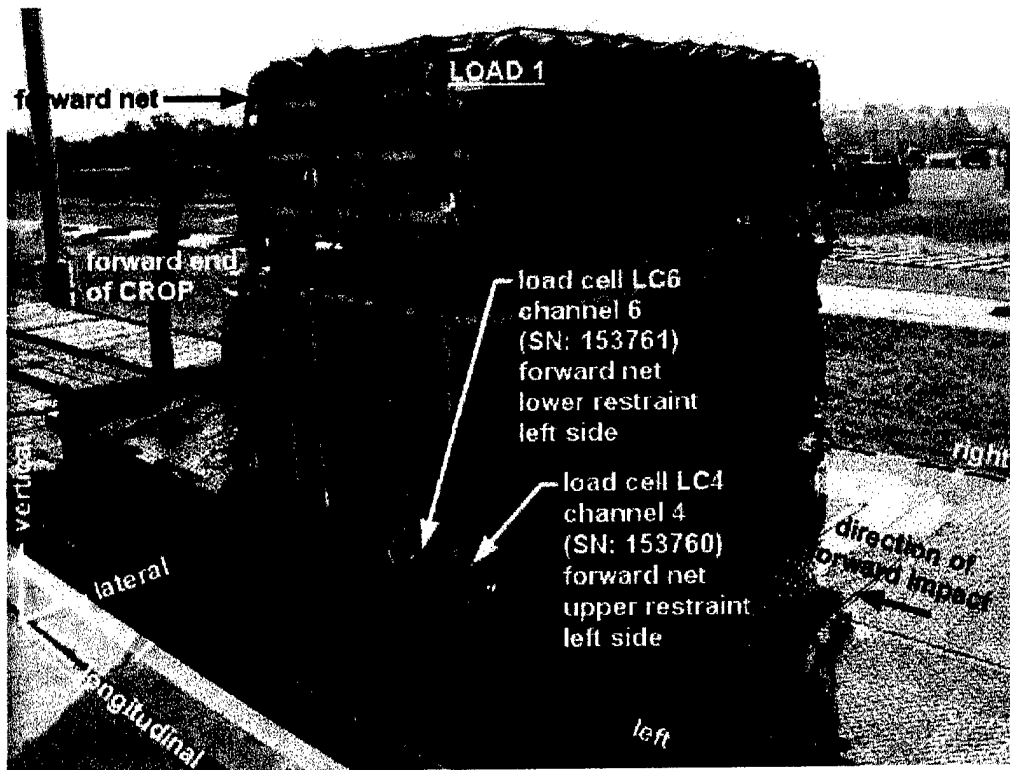

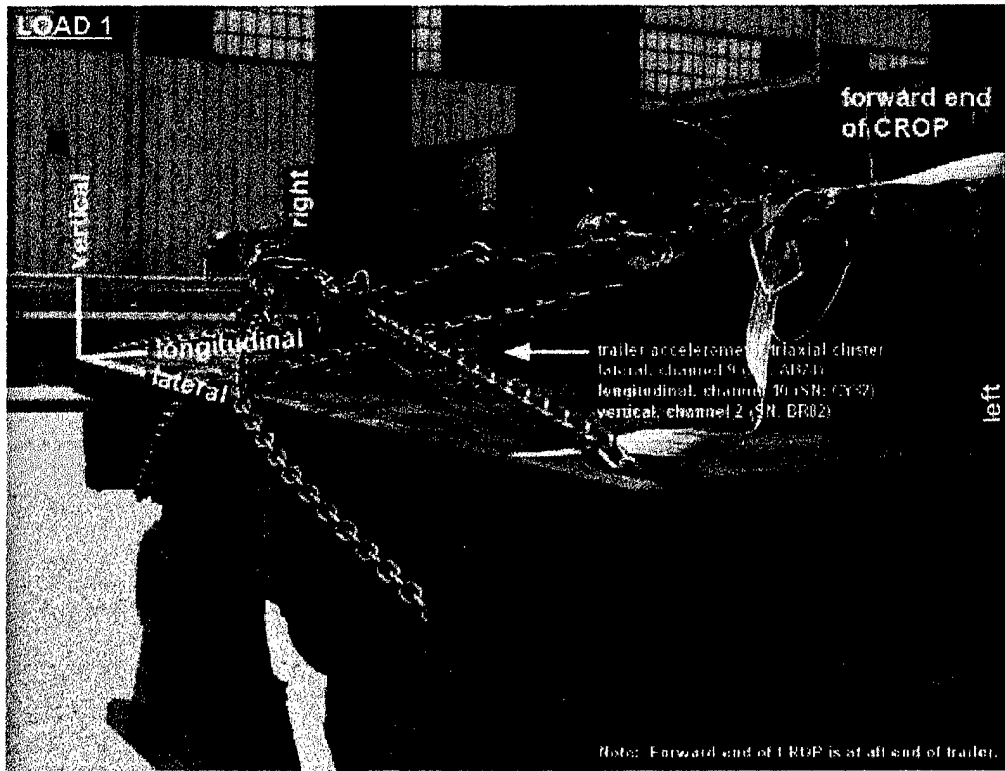

LOAD 1 - RAIL IMPACT - 4.50 MPH - Load Cells 4, 5, 6, and 7

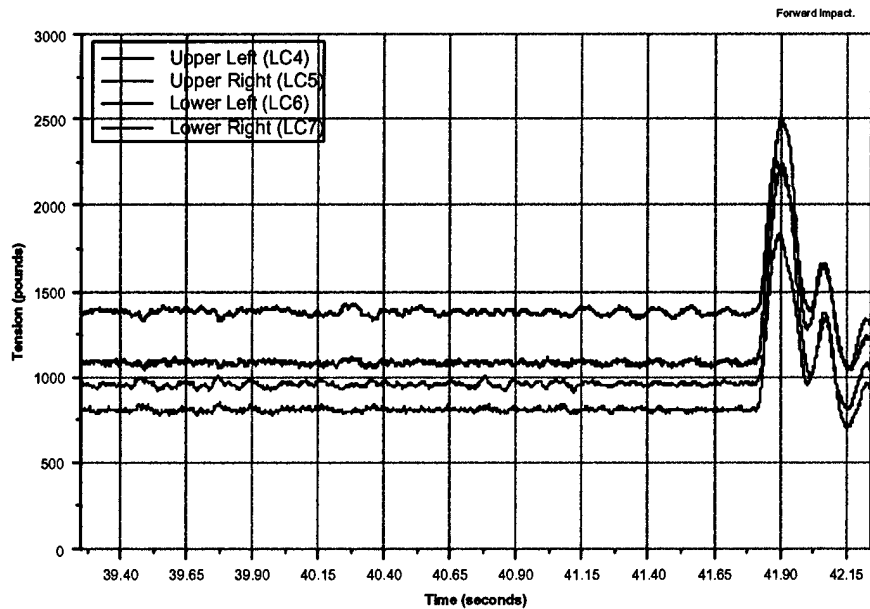

LOAD 1 - RAIL IMPACT - 4.50 MPH - Load Cell 4

Forward Impact,
Forward Net,
Left Side,
Upper Restraint.

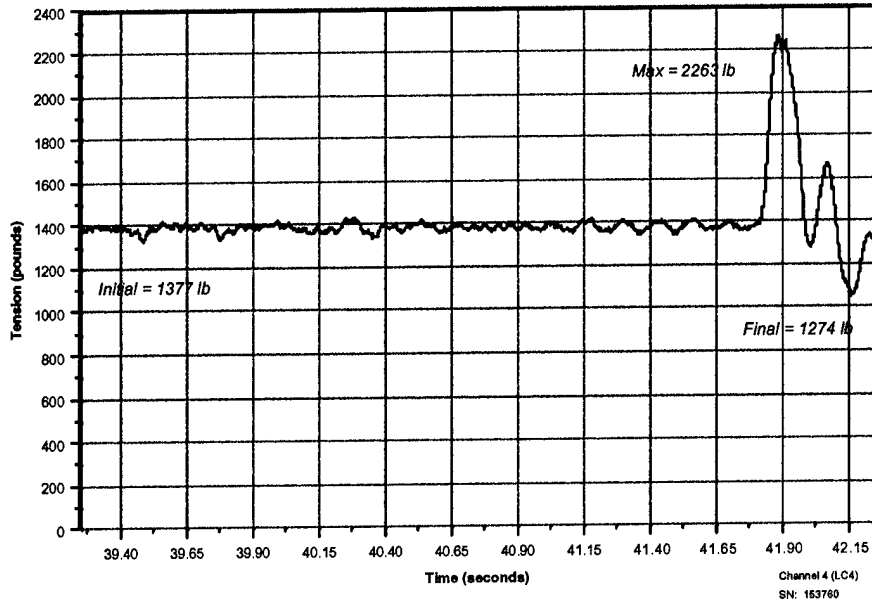

LOAD 1 - RAIL IMPACT - 4.50 MPH - Load Cell 5

Forward Impact,
Forward Net,
Right Side,
Upper Restraint.

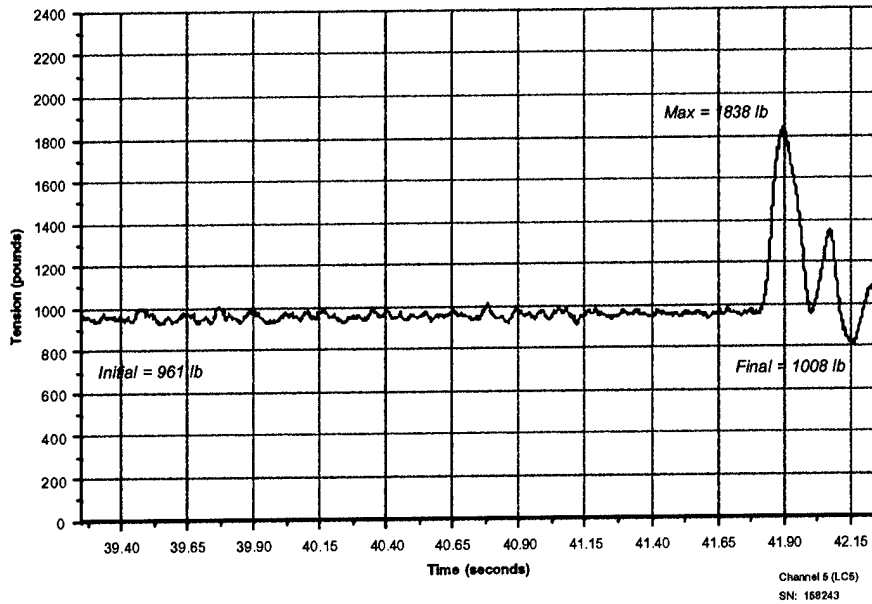

LOAD 1 - RAIL IMPACT - 4.50 MPH - Load Cell 6

Forward Impact,
Forward Net,
Left Side,
Lower Restraint.

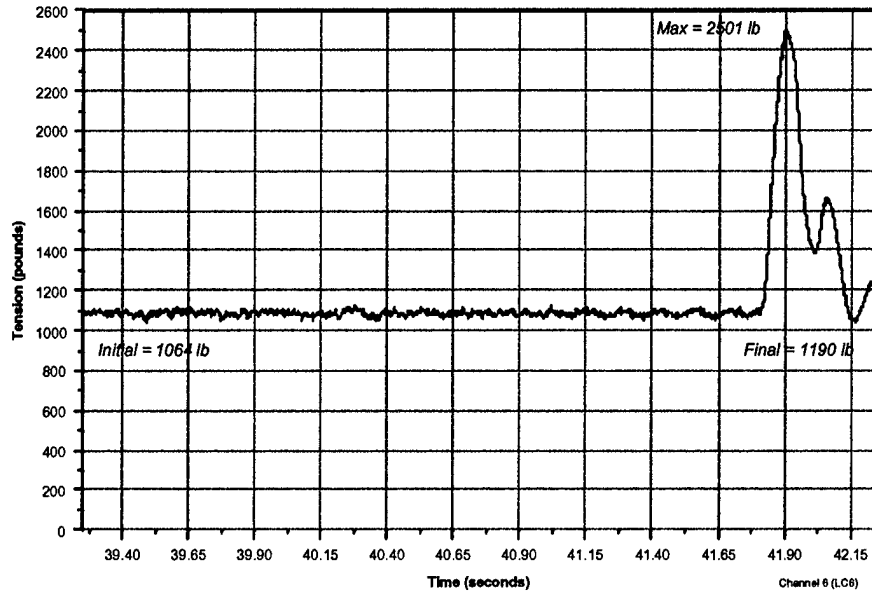

LOAD 1 - RAIL IMPACT - 4.50 MPH - Load Cell 7

Forward Impact,
Forward Net,
Right Side,
Lower Restraint.

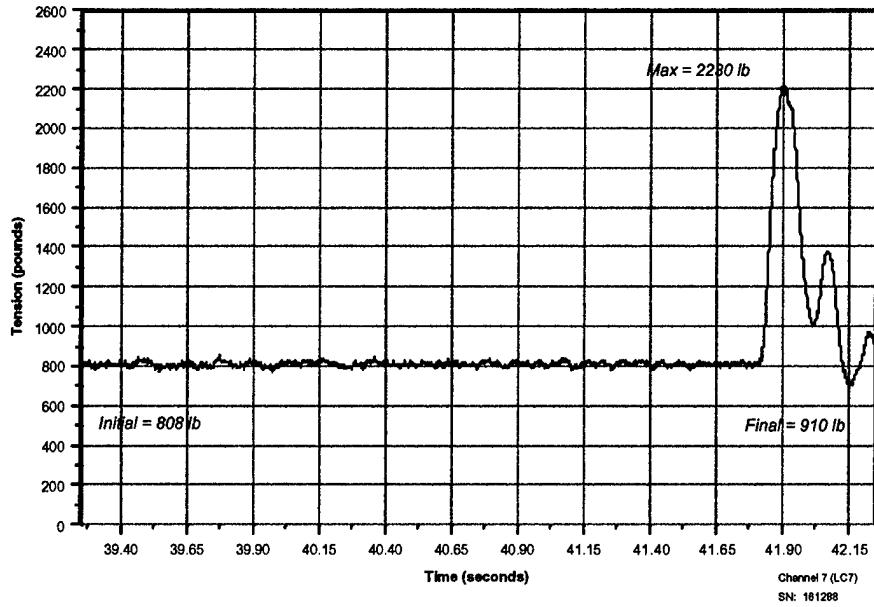

LOAD 1 - RAIL IMPACT - 6.29 MPH - Load Cells 4, 5, 6, and 7

Forward Impact.

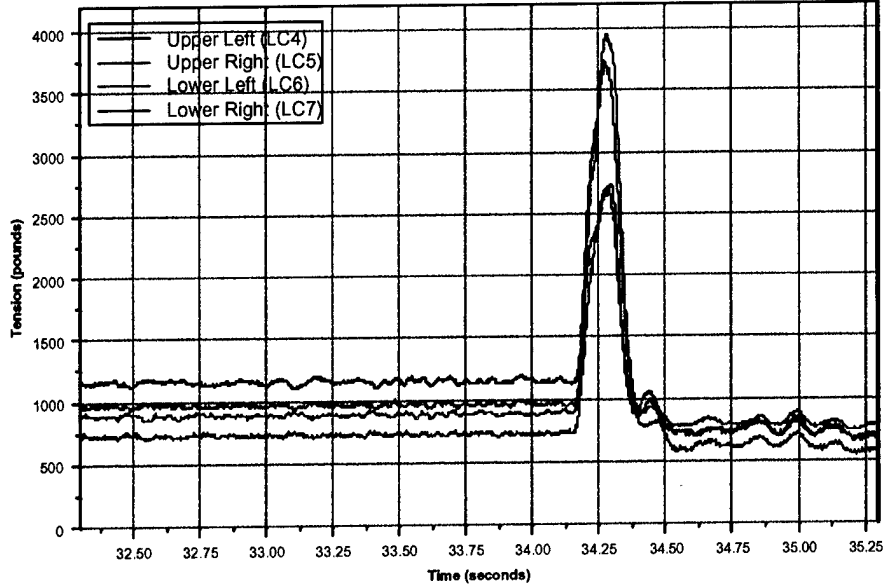

LOAD 1 - RAIL IMPACT - 6.29 MPH - Load Cell 4

Forward Impact,
Forward Net,
Left Side,
Upper Restraint.

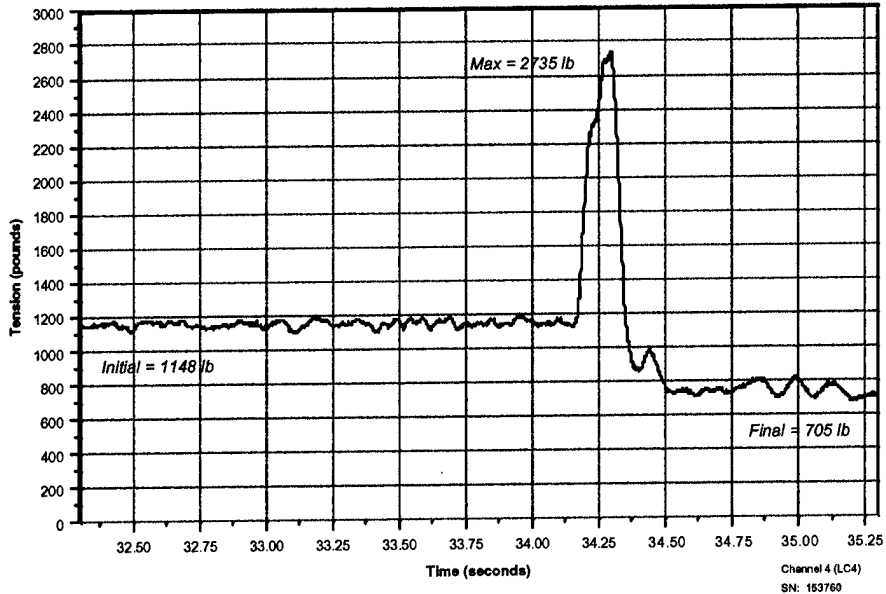

LOAD 1 - RAIL IMPACT - 6.29 MPH - Load Cell 5

Forward Impact,
Forward Net,
Right Side,
Upper Restraint.

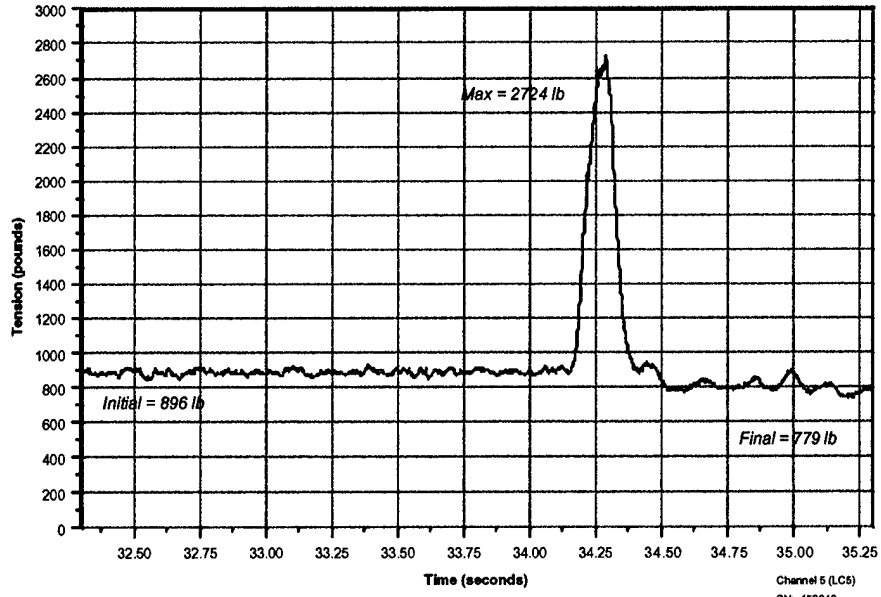

LOAD 1 - RAIL IMPACT - 6.29 MPH - Load Cell 6

Forward Impact,
Forward Net,
Left Side,
Lower Restraint.

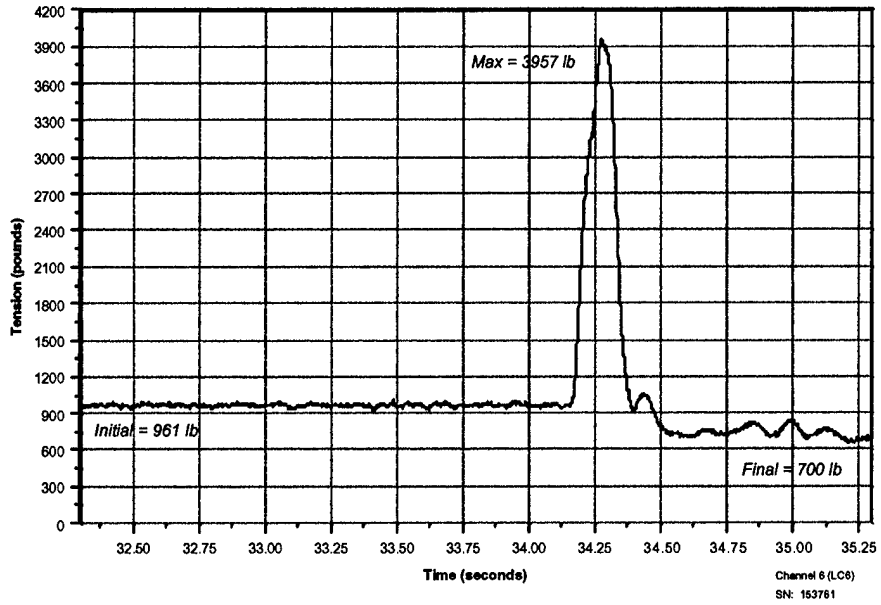

LOAD 1 - RAIL IMPACT - 6.29 MPH - Load Cell 7

Forward Impact,
Forward Net,
Right Side,
Lower Restraint.

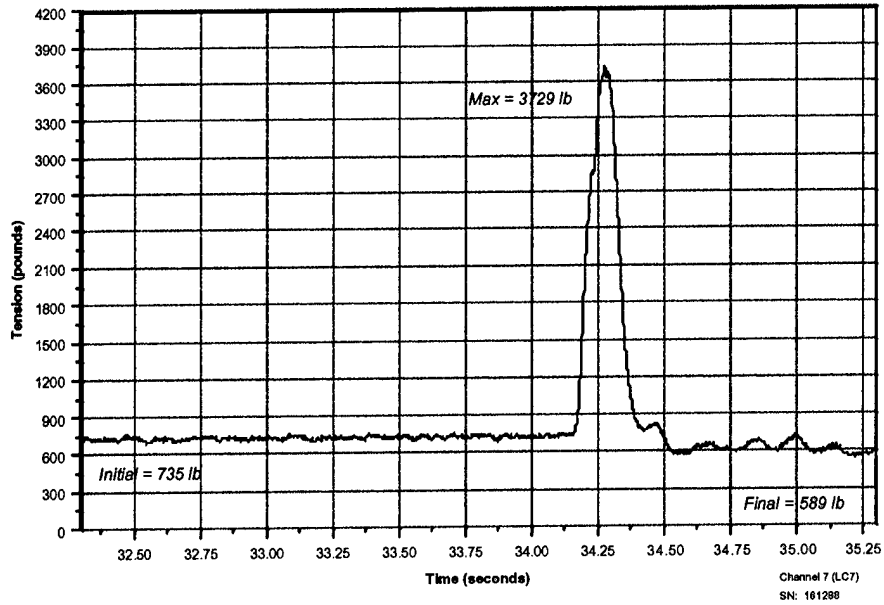

LOAD 1 - RAIL IMPACT - 8.15 MPH - Load Cells 4, 5, 6, and 7

Forward Impact.

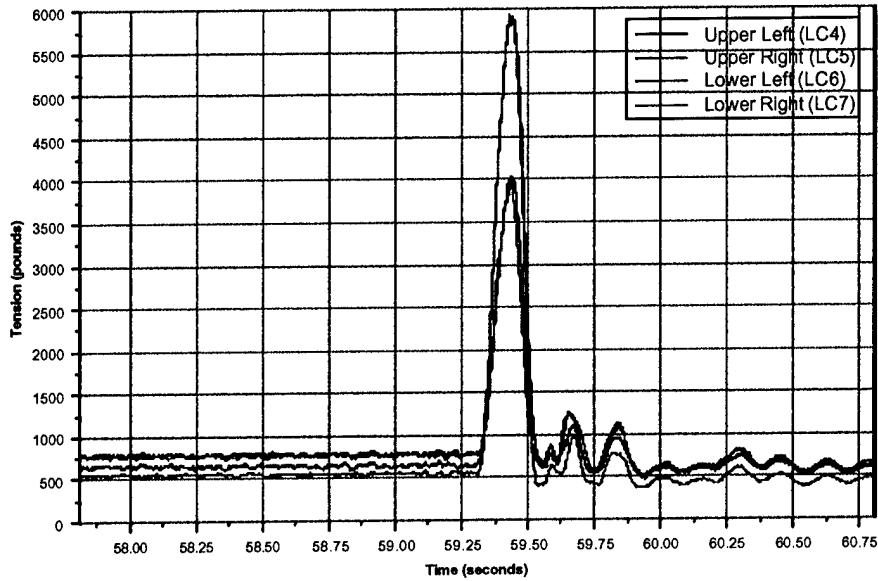

LOAD 1 - RAIL IMPACT - 8.15 MPH - Load Cell 4

Forward Impact,
Forward Net,
Left Side,
Upper Restraint.

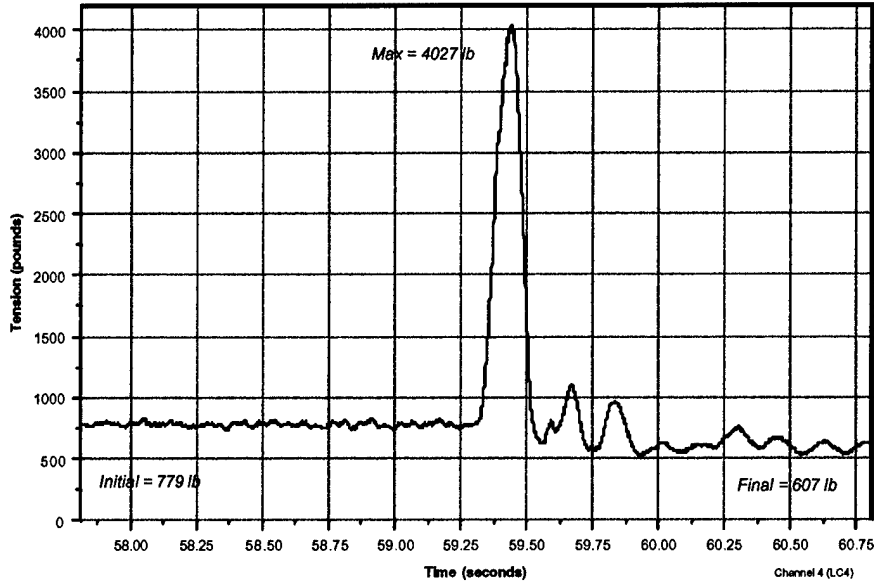

LOAD 1 - RAIL IMPACT - 8.15 MPH - Load Cell 5

Forward Impact,
Forward Net,
Right Side,
Upper Restraint.

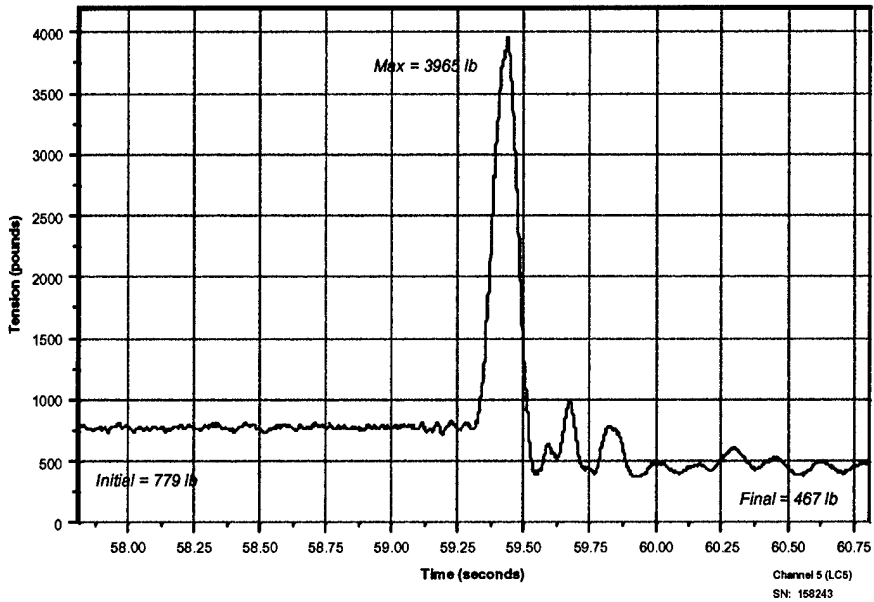

LOAD 1 - RAIL IMPACT - 8.15 MPH - Load Cell 6

Forward Impact,
Forward Net,
Left Side,
Lower Restraint.

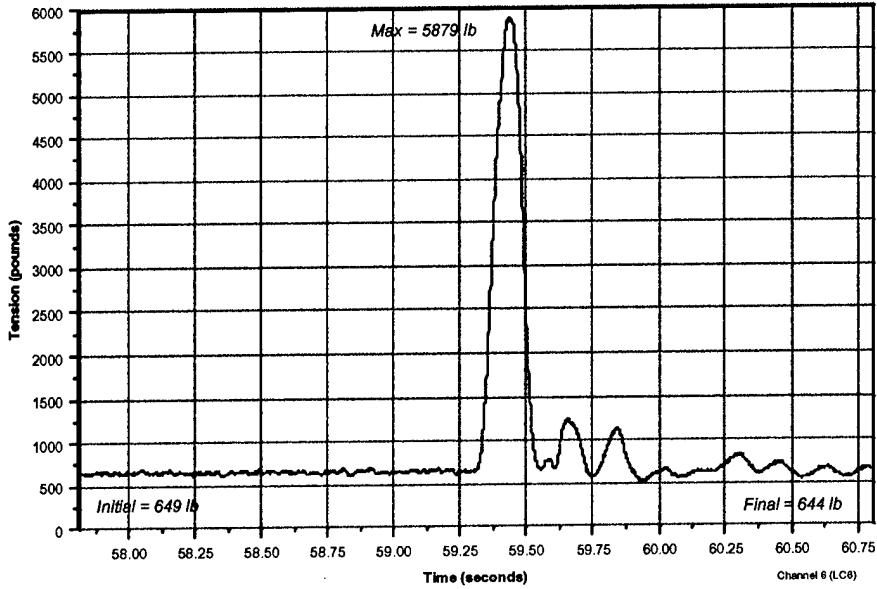

LOAD 1 - RAIL IMPACT - 8.15 MPH - Load Cell 7

Forward Impact,
Forward Net,
Right Side,
Lower Restraint.

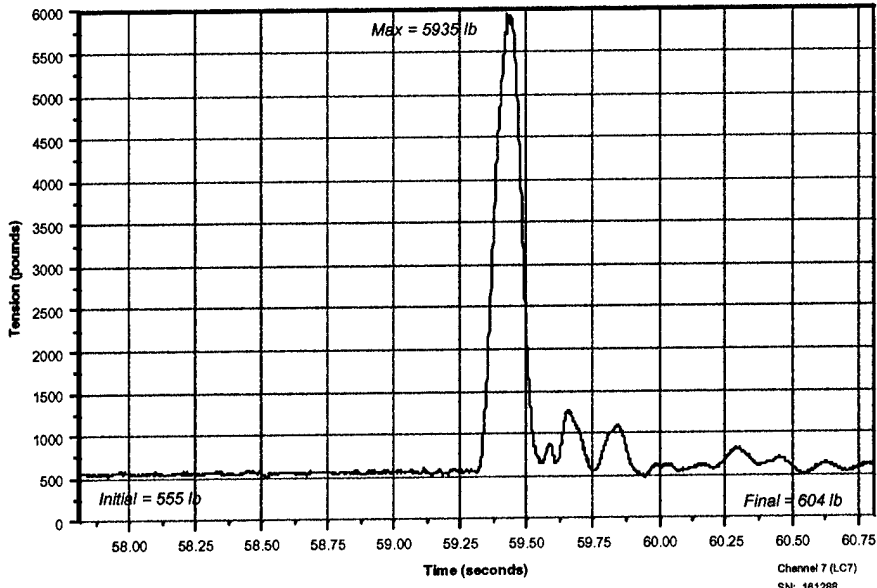

LOAD 1 - WASHBOARD - Load Cell 4

Forward Net,
Left Side of CROP,
Upper Restraint.

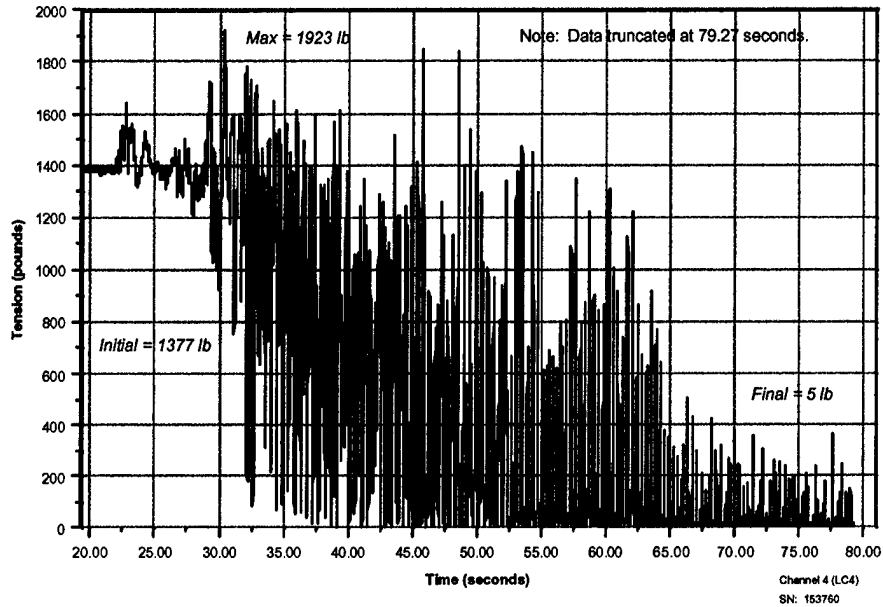

LOAD 1 - WASHBOARD - Load Cell 5

Forward Net,
Right Side of CROP,
Upper Restraint.

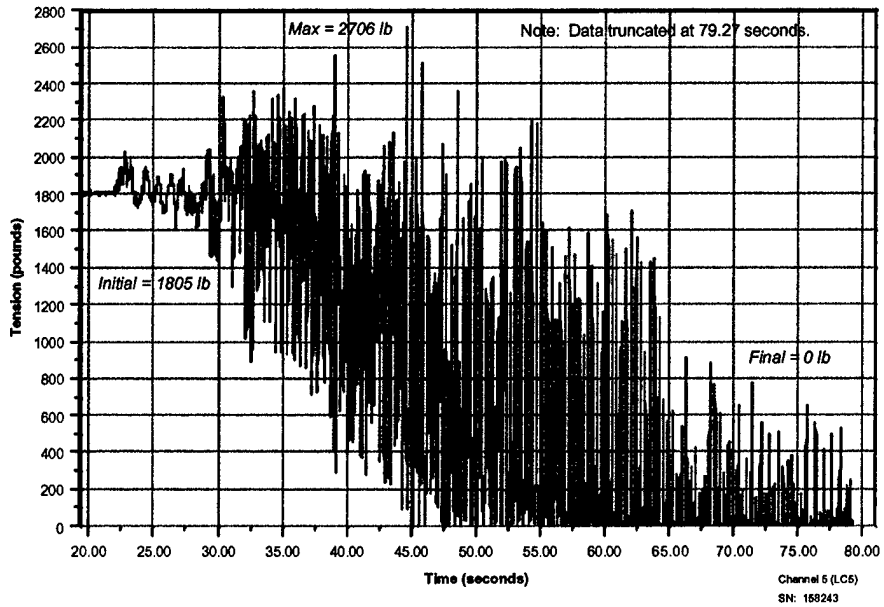

LOAD 1 - WASHBOARD - Load Cell 6

Forward Net,
Left Side of CROP,
Lower Restraint.

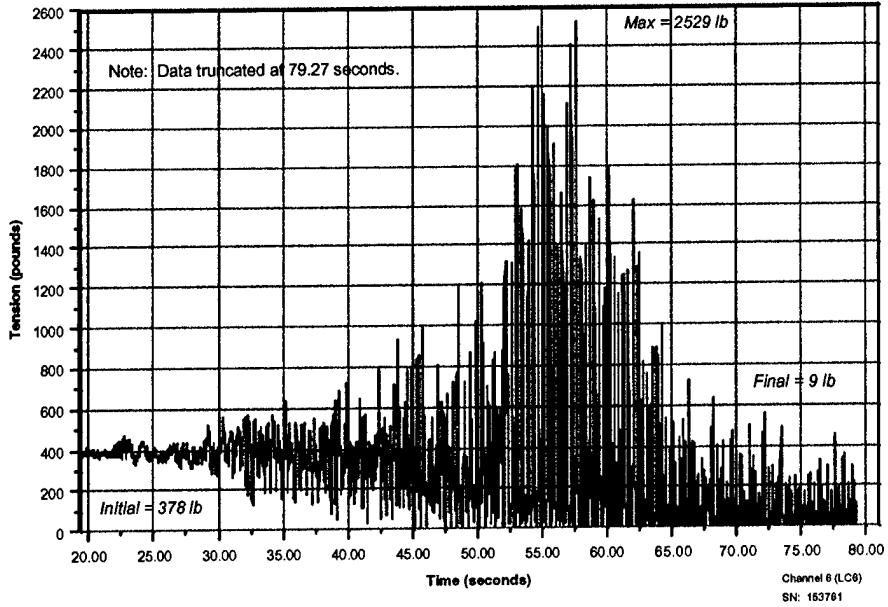

LOAD 1 - WASHBOARD - Load Cell 7

Forward Net,
Right Side of CROP,
Lower Restraint.

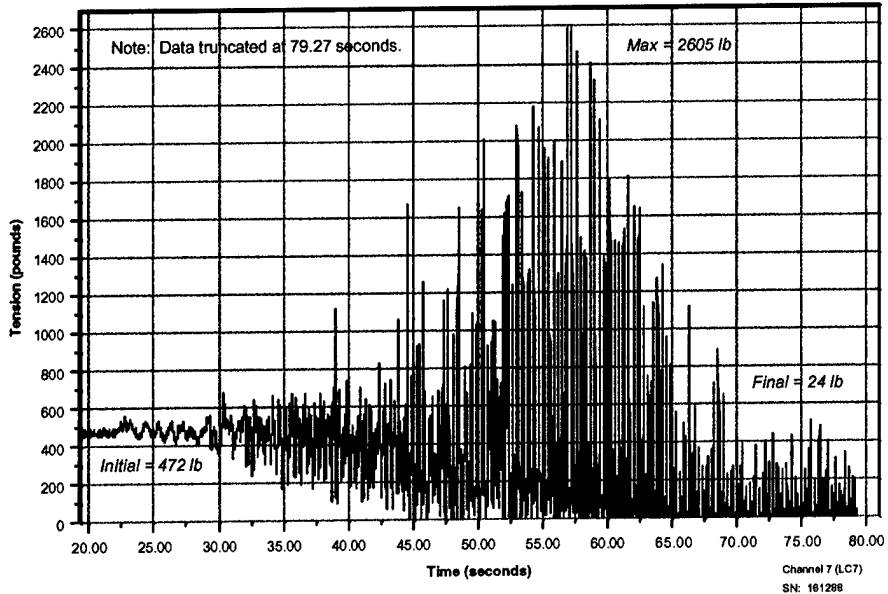

C455 LOAD BAY SENSOR LOCATION

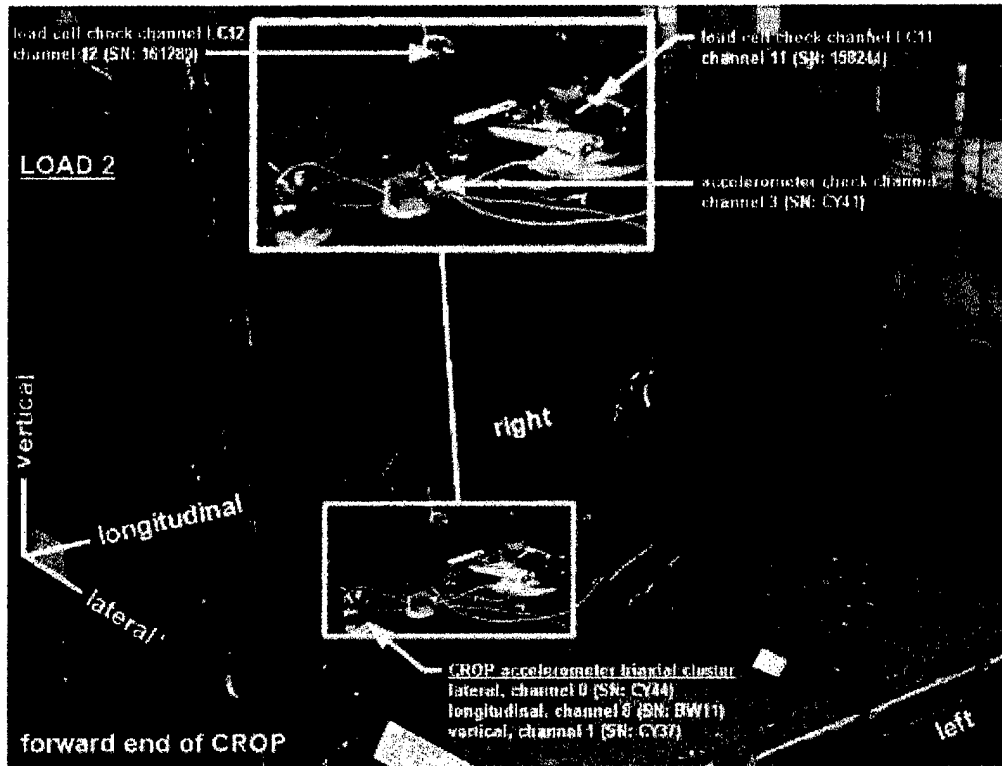

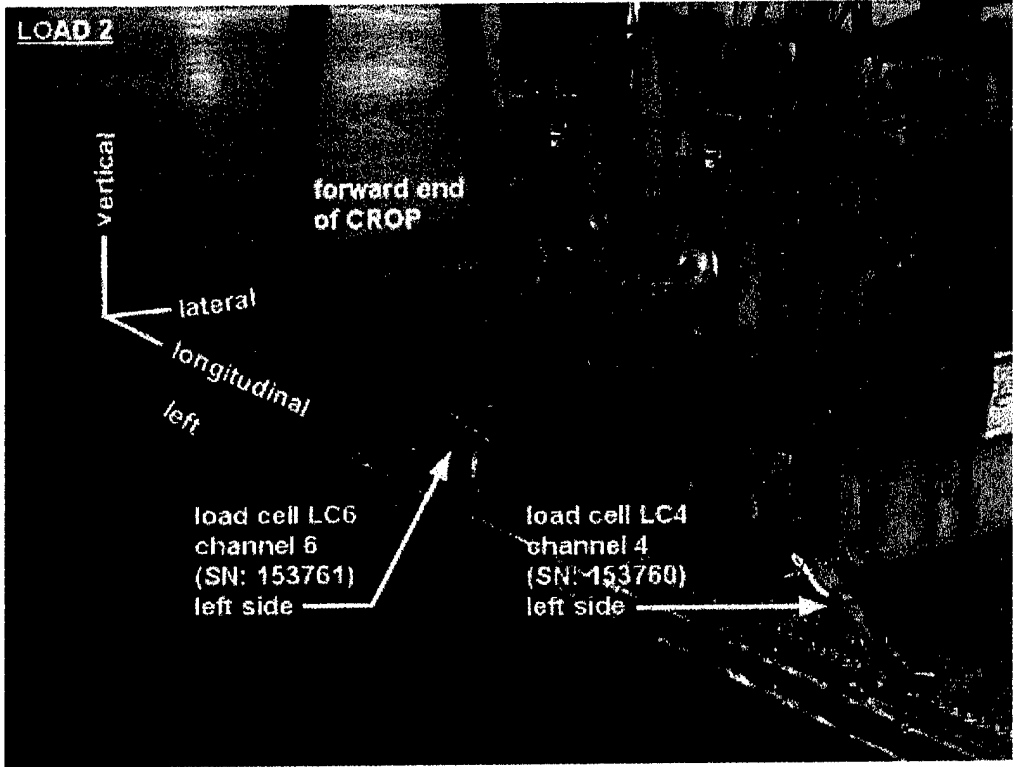

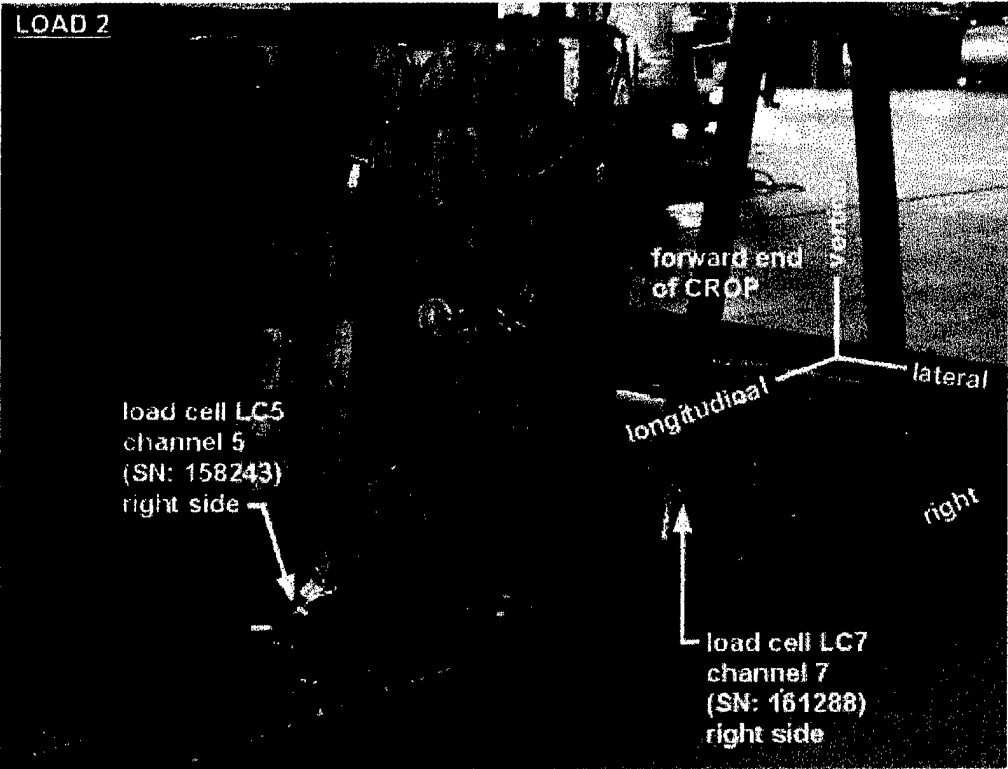

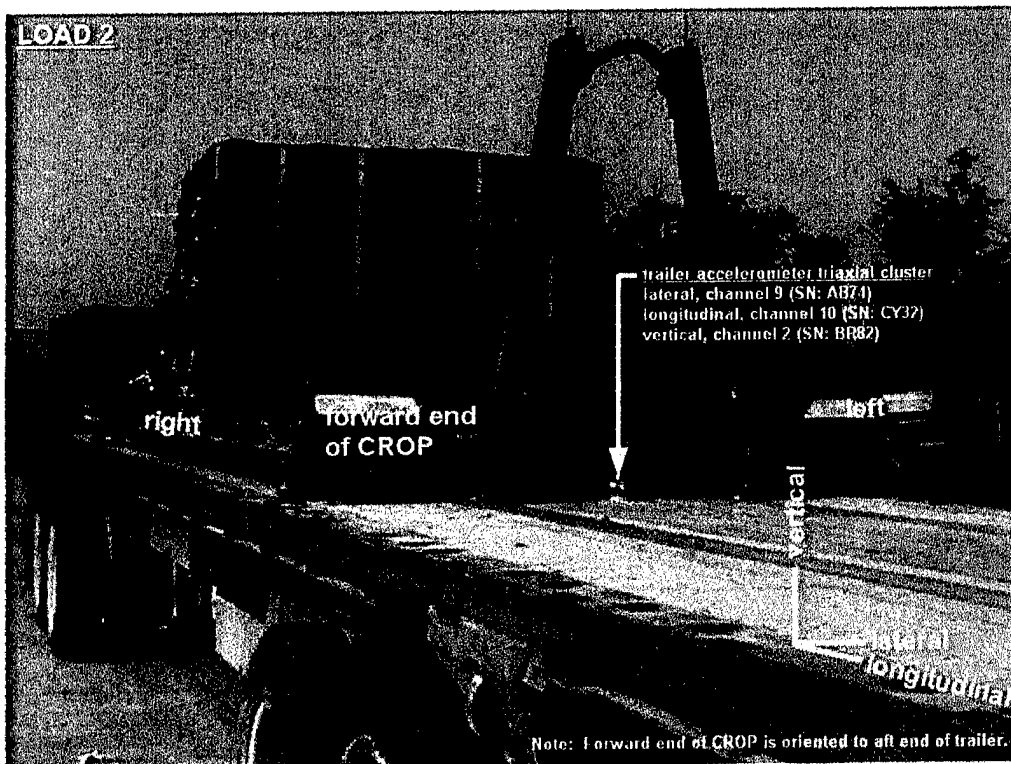
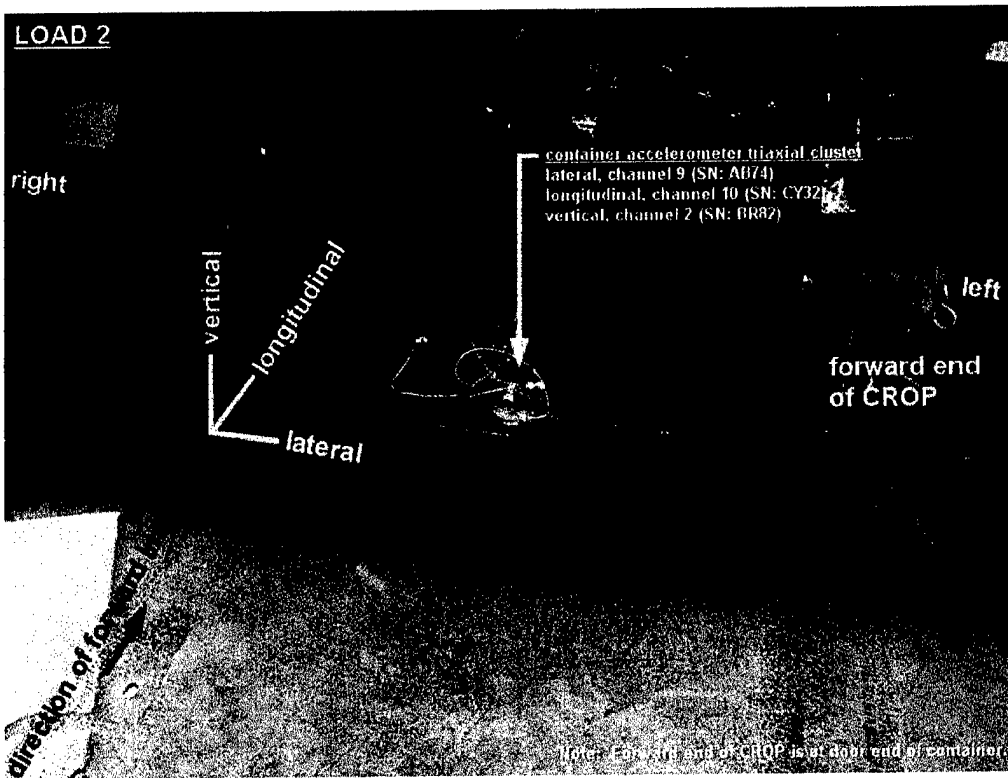

LOAD 2 - RAIL IMPACT 1 - 4.53 MPH - Load Cells 4, 5, 6, and 7

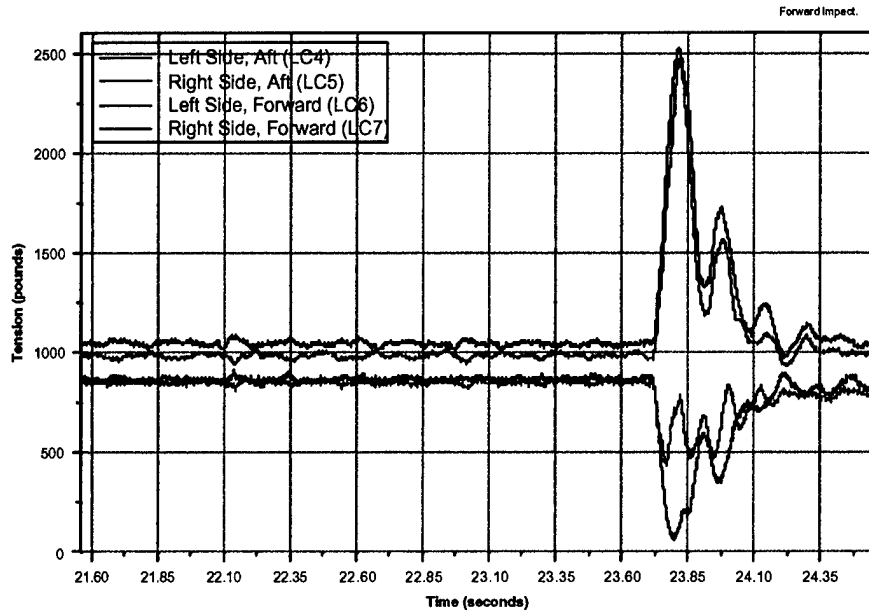

LOAD 2 - RAIL IMPACT 1 - 4.53 MPH - Load Cell 4

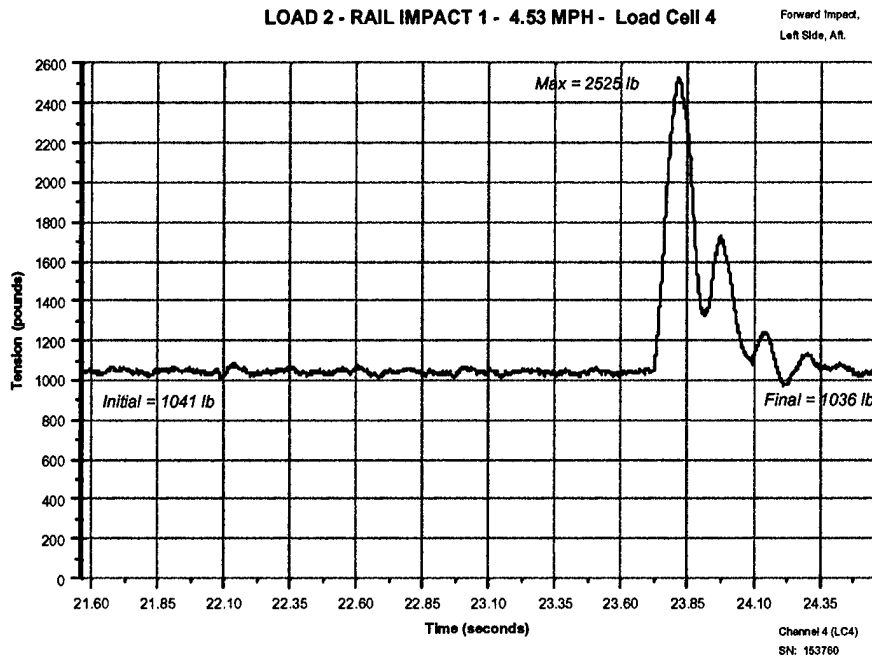

LOAD 2 - RAIL IMPACT 1 - 4.53 MPH - Load Cell 5

Forward Impact,
Right Side, Aft.

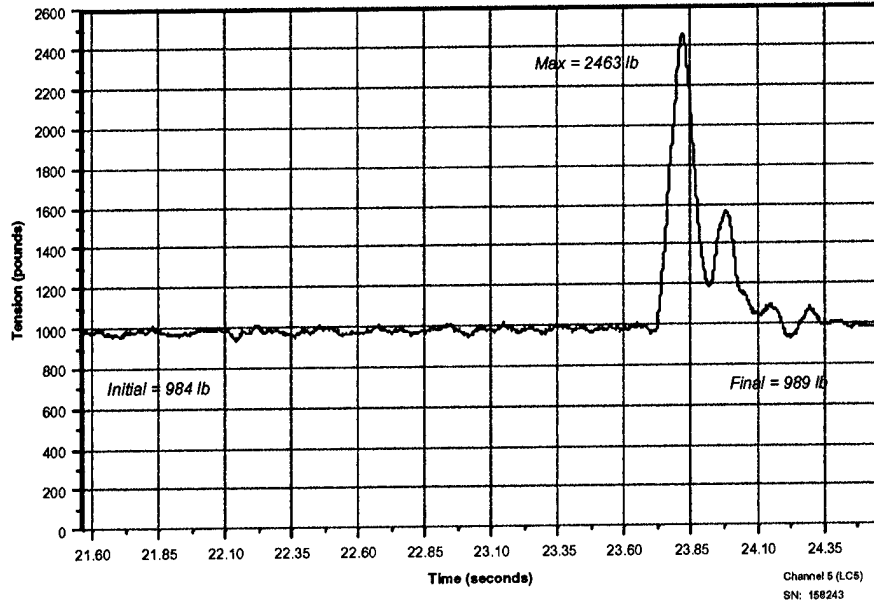

LOAD 2 - RAIL IMPACT 1 - 4.53 MPH - Load Cell 6

Forward Impact,
Left Side, Forward.

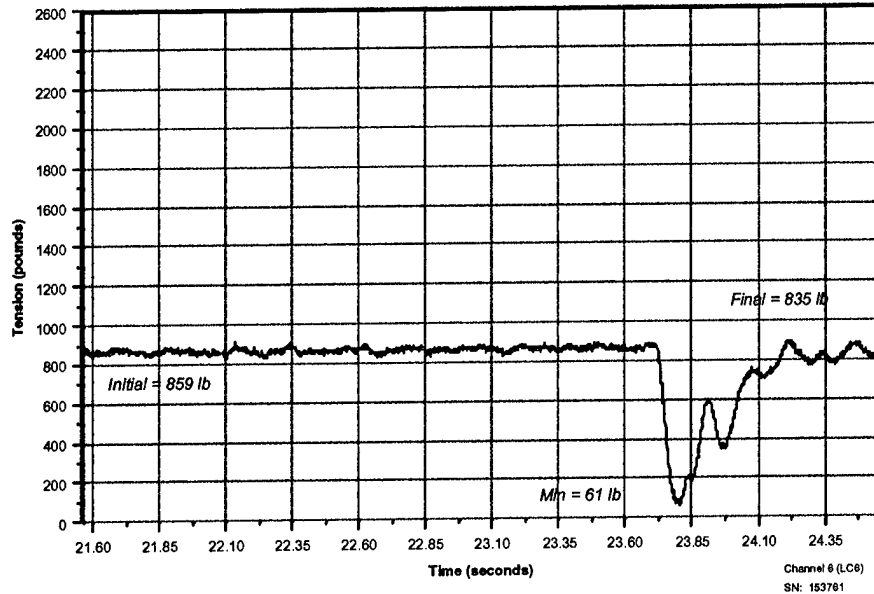

LOAD 2 - RAIL IMPACT 1 - 4.53 MPH - Load Cell 7

Forward Impact,
Right Side, Forward.

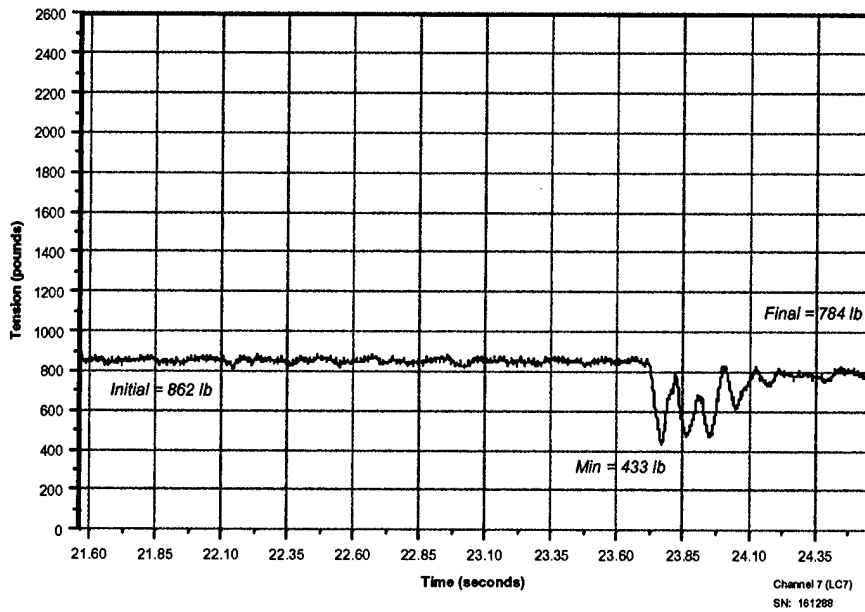

LOAD 2 - RAIL IMPACT 1 - 5.72 MPH - Load Cells 4, 5, 6, and 7

Forward Impact.

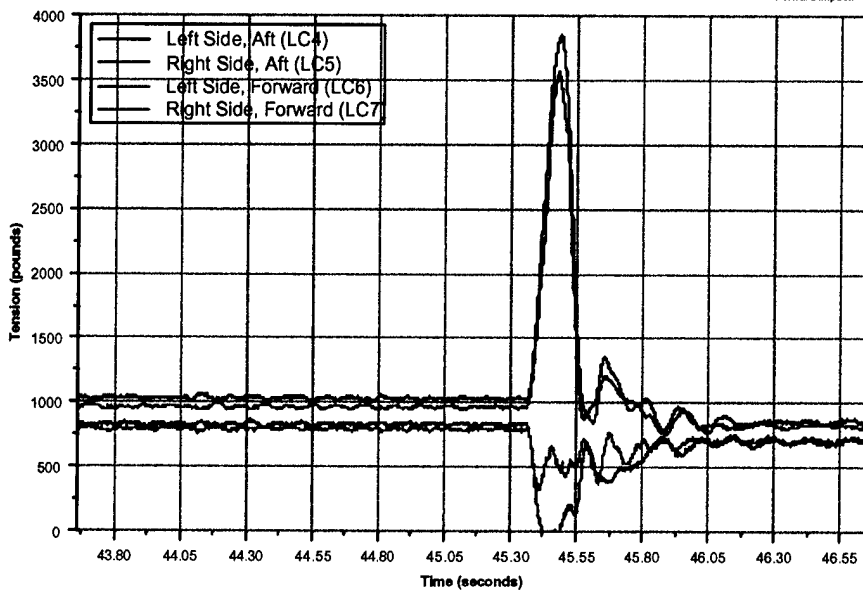

LOAD 2 - RAIL IMPACT 1 - 5.72 MPH - Load Cell 4

Forward Impact,
Left Side, A.R.

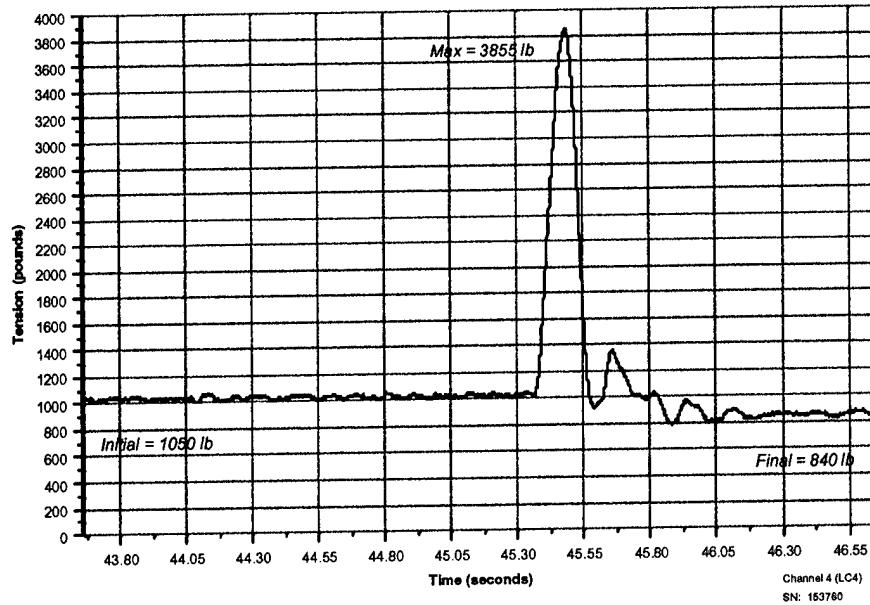

LOAD 2 - RAIL IMPACT 1 - 5.72 MPH - Load Cell 5

Forward Impact,
Right Side, A.R.

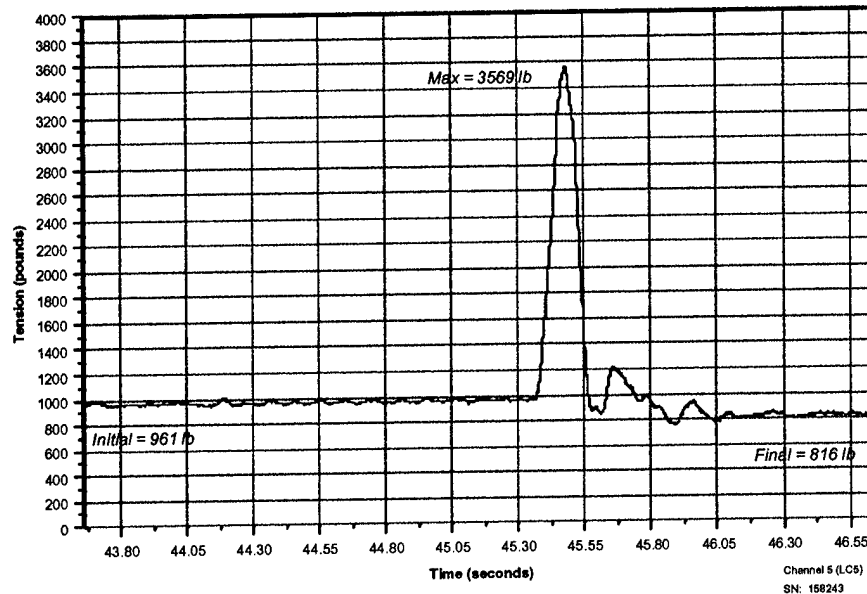

LOAD 2 - RAIL IMPACT 1 - 5.72 MPH - Load Cell 6

Forward Impact,
Left Side, Forward.

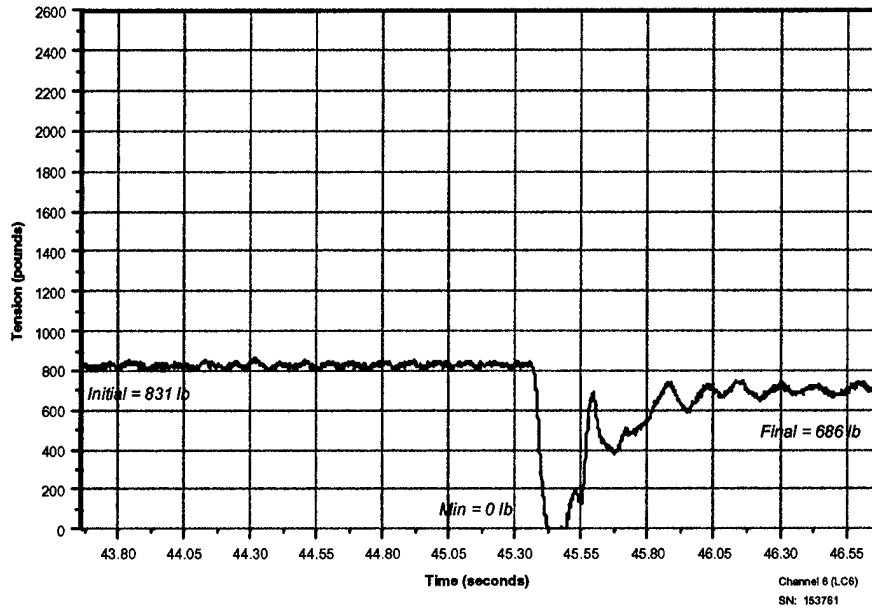

LOAD 2 - RAIL IMPACT 1 - 5.72 MPH - Load Cell 7

Forward Impact,
Right Side, Forward.

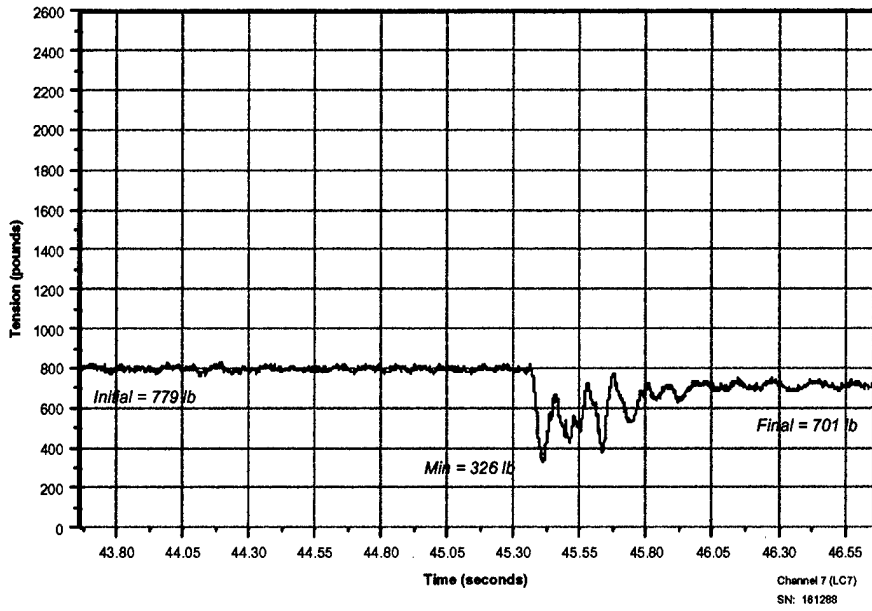

LOAD 2 - RAIL IMPACT 1 - 6.11 MPH - Load Cells 4, 5, 6, and 7

Forward Impact.

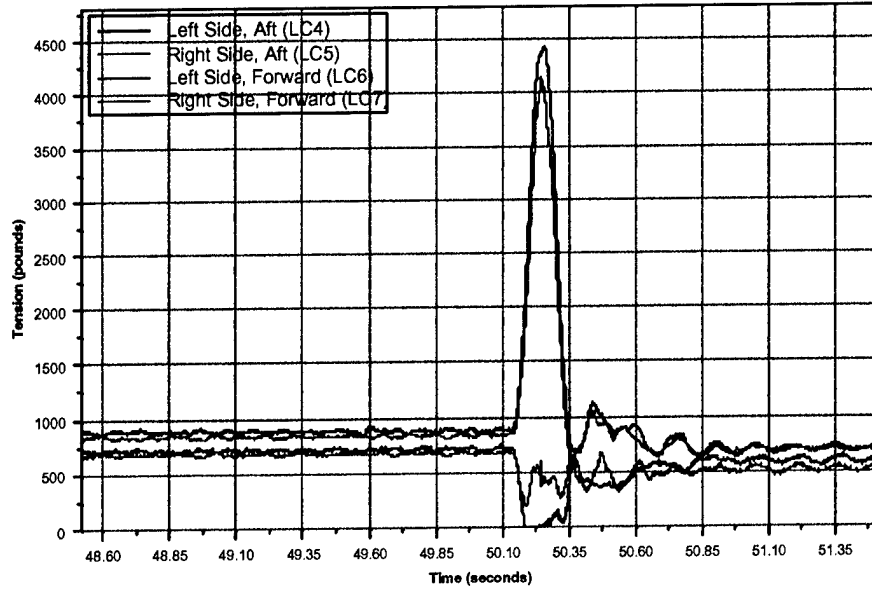

LOAD 2 - RAIL IMPACT 1 - 6.11 MPH - Load Cell 4

Forward Impact,
Left Side, Aft.

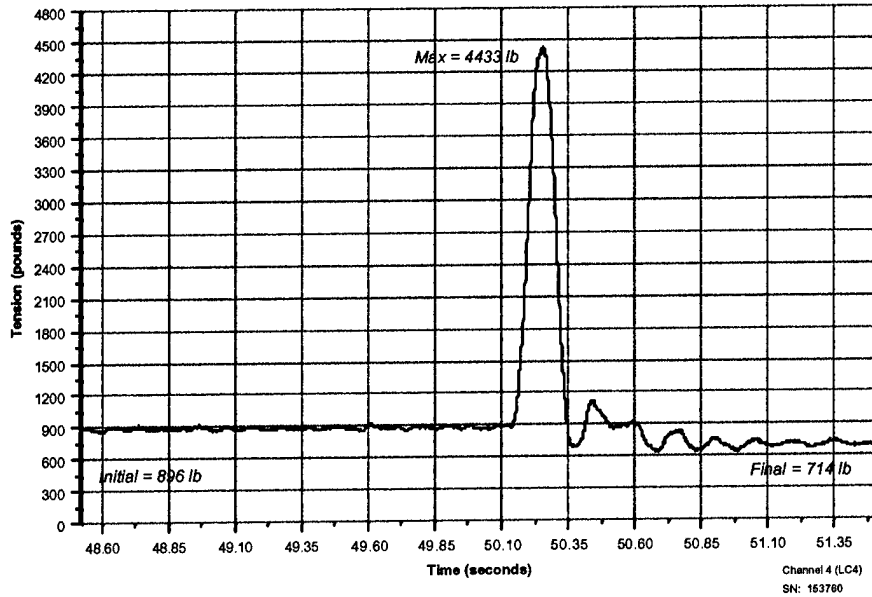

LOAD 2 - RAIL IMPACT 1 - 6.11 MPH - Load Cell 5

Forward Impact,
Right Side, Aft.

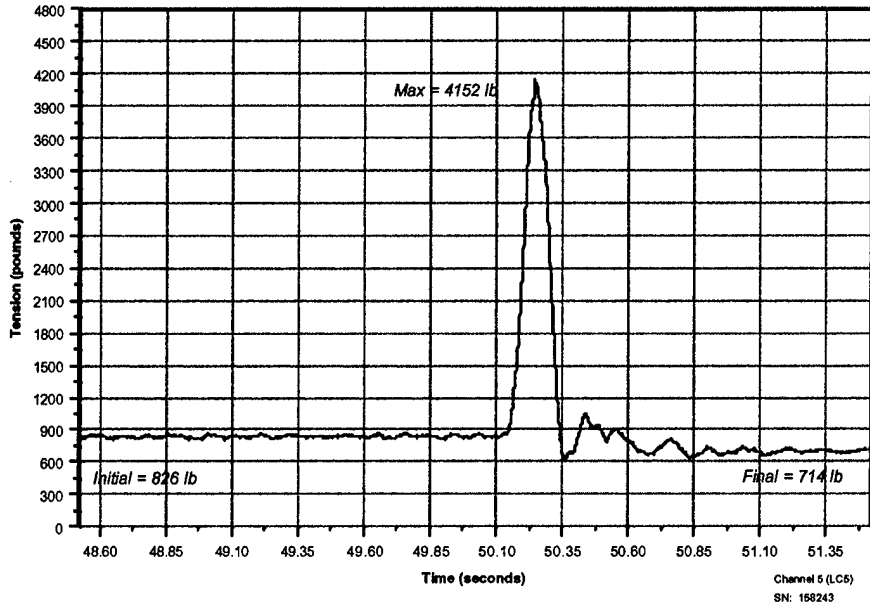

LOAD 2 - RAIL IMPACT 1 - 6.11 MPH - Load Cell 6

Forward Impact,
Left Side, Forward.

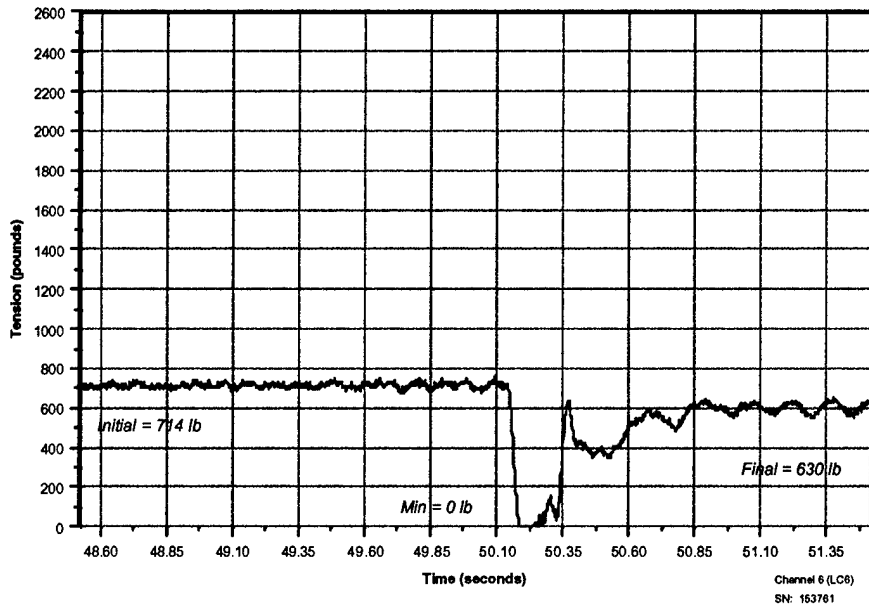

LOAD 2 - RAIL IMPACT 1 - 6.11 MPH - Load Cell 7

Forward Impact,
Right Side, Forward.

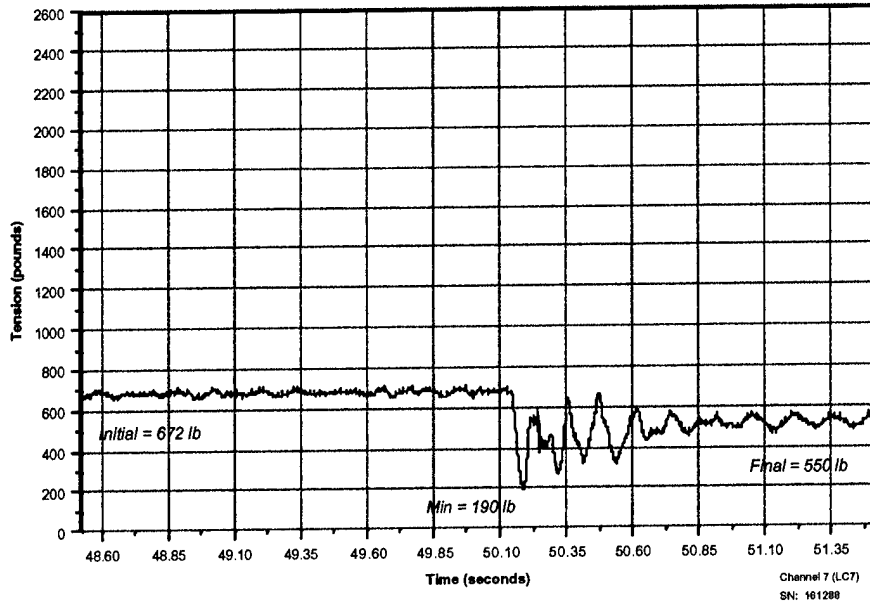

LOAD 2 - RAIL IMPACT 1 - 6.97 MPH - Load Cells 4, 5, 6, and 7

Forward Impact.

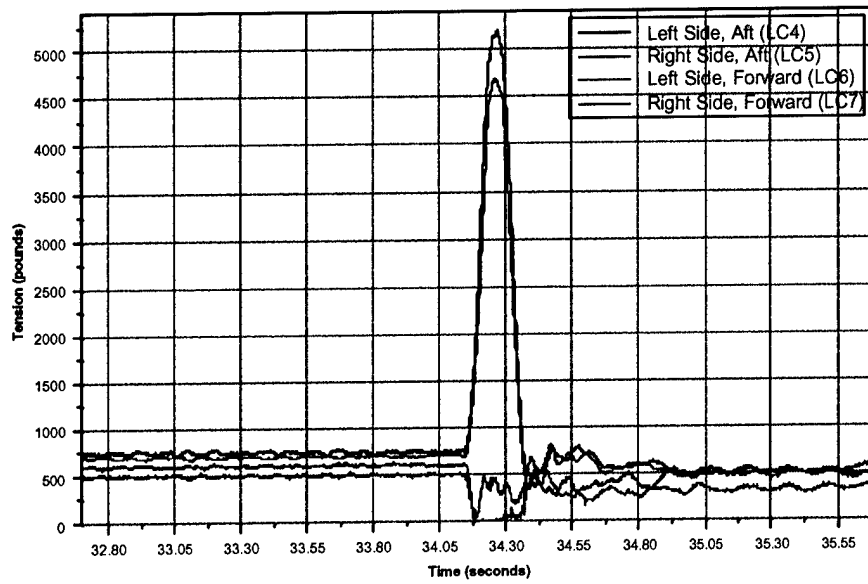

LOAD 2 - RAIL IMPACT 1 - 6.97 MPH - Load Cell 4

Forward Impact,
Left Side, Aft.

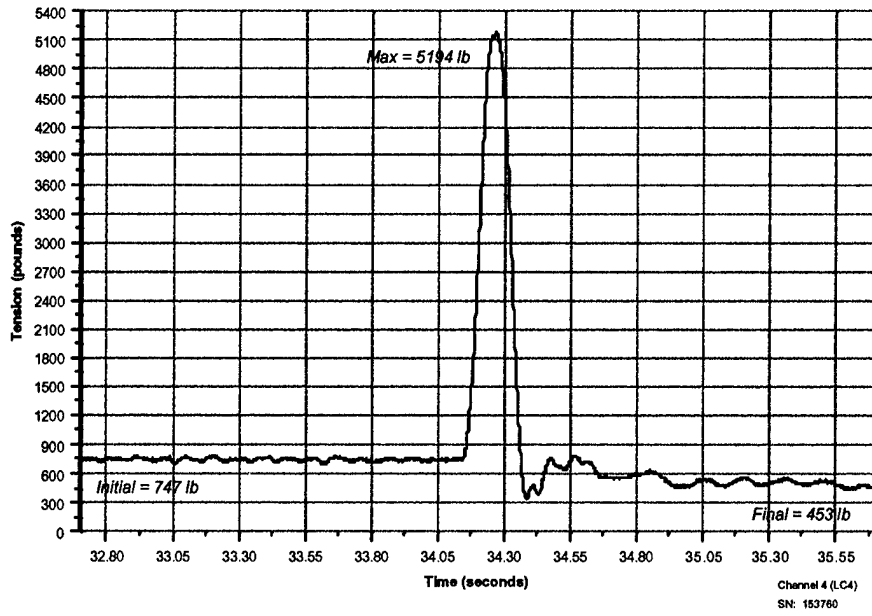

LOAD 2 - RAIL IMPACT 1 - 6.97 MPH - Load Cell 5

Forward Impact,
Right Side, Aft.

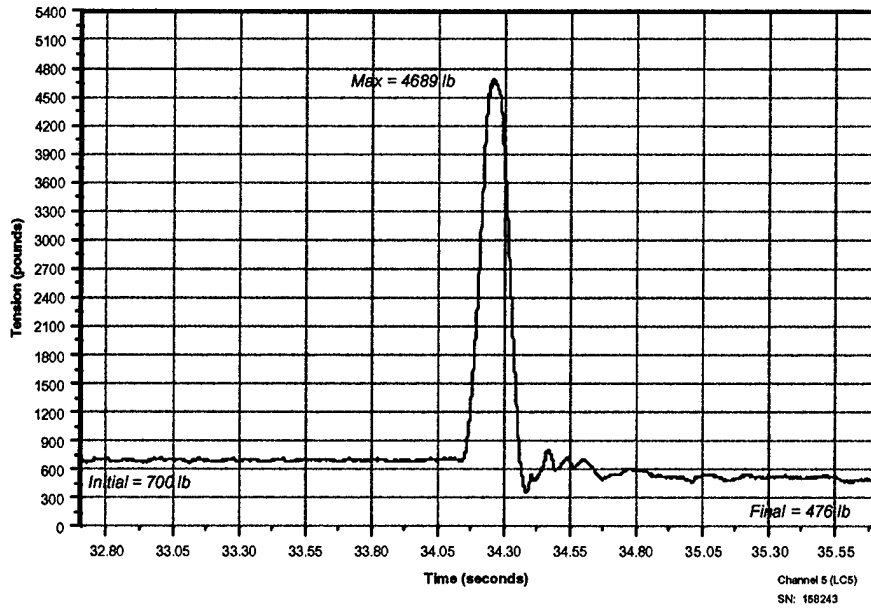

LOAD 2 - RAIL IMPACT 1 - 6.97 MPH - Load Cell 6

Forward Impact,
Left Side, Forward.

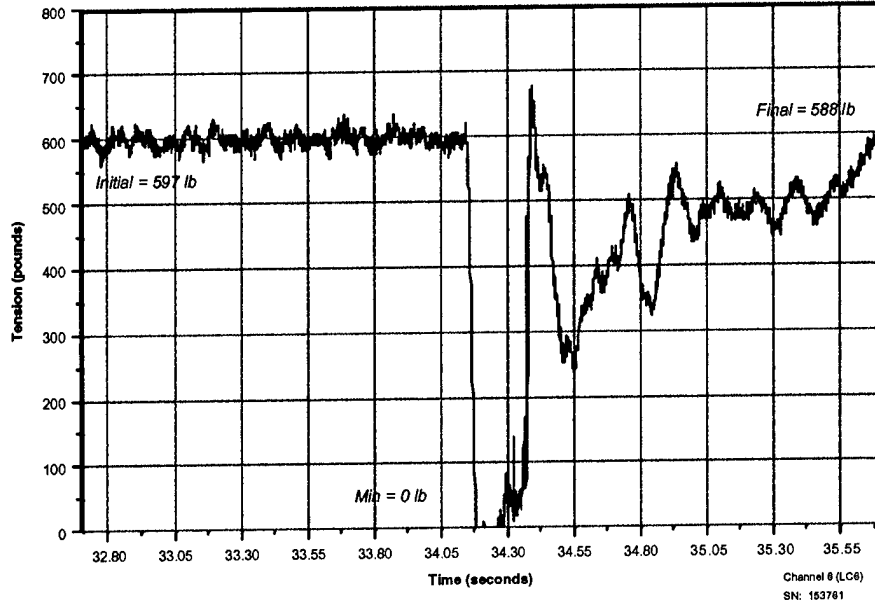

LOAD 2 - RAIL IMPACT 1 - 6.97 MPH - Load Cell 7

Forward Impact,
Right Side, Forward.

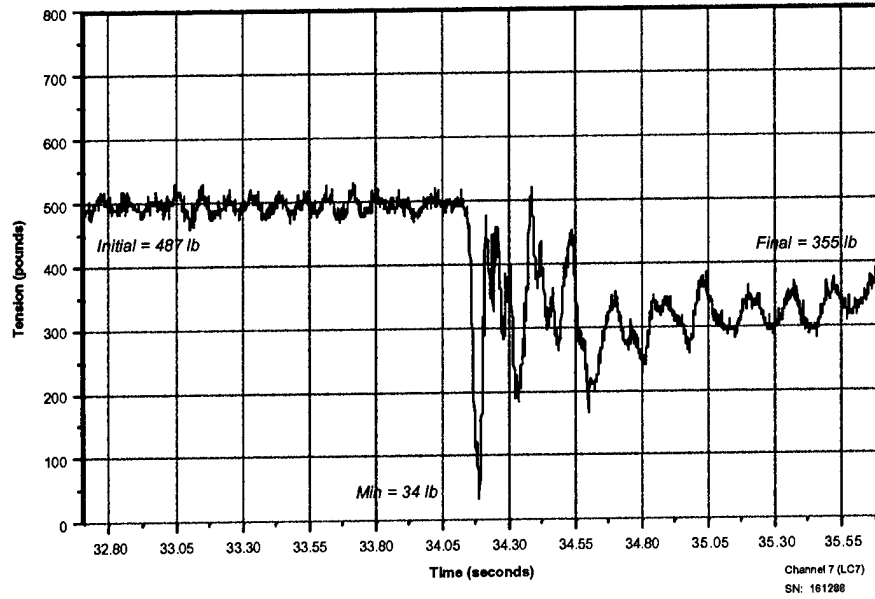

LOAD 2 - RAIL IMPACT 1 - 7.73 MPH - Tension

Forward Impact.

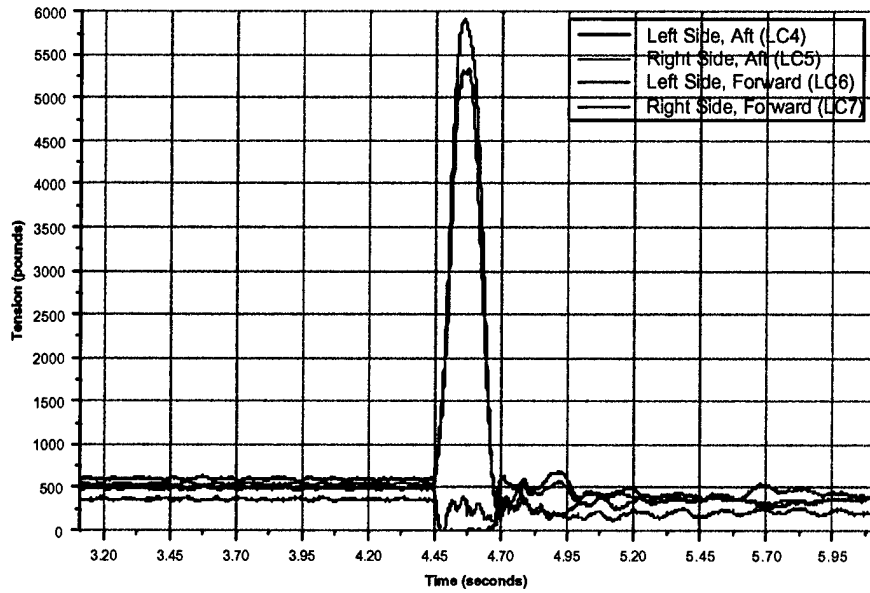

LOAD 2 - RAIL IMPACT 1 - 7.73 MPH - Load Cell 4

Forward Impact.
Left Side, Aft.

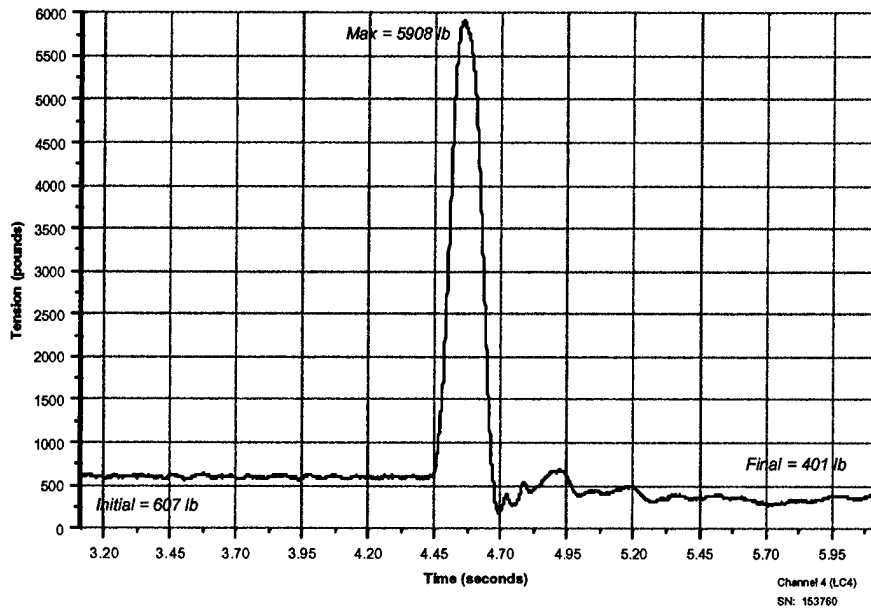

LOAD 2 - RAIL IMPACT 1 - 7.73 MPH - Load Cell 5

Forward Impact,
Right Side, Aft.

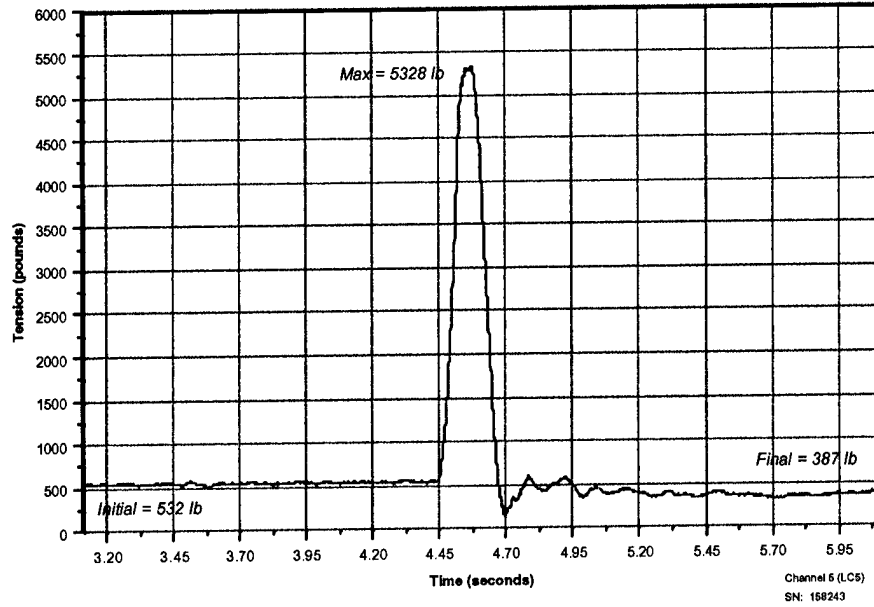

LOAD 2 - RAIL IMPACT 1 - 7.73 MPH - Load Cell 6

Forward Impact,
Left Side, Forward.

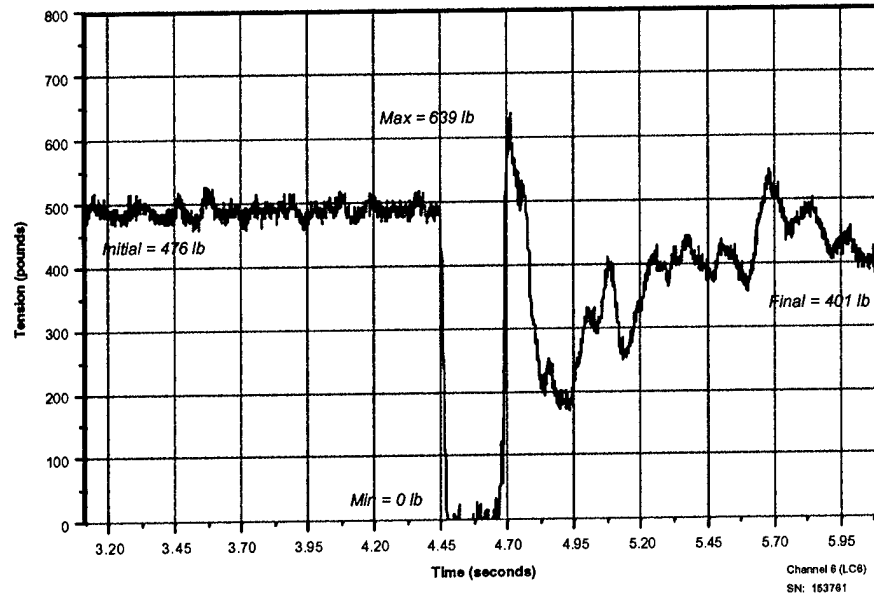

LOAD 2 - RAIL IMPACT 1 - 7.73 MPH - Load Cell 7

Forward Impact,
Right Side, Forward.

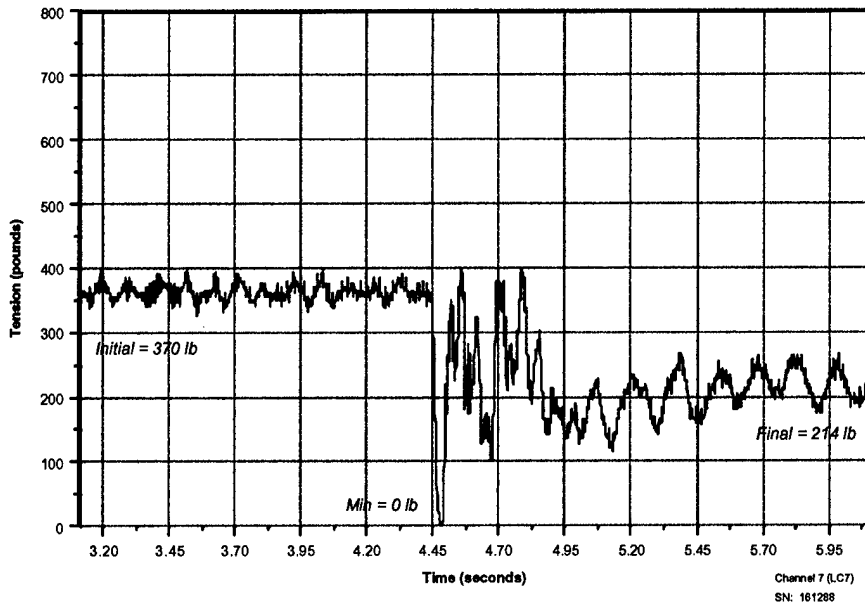

LOAD 2 - RAIL IMPACT 1 - 8.48 MPH - Load Cells 4, 5, 6, and 7

Forward Impact.

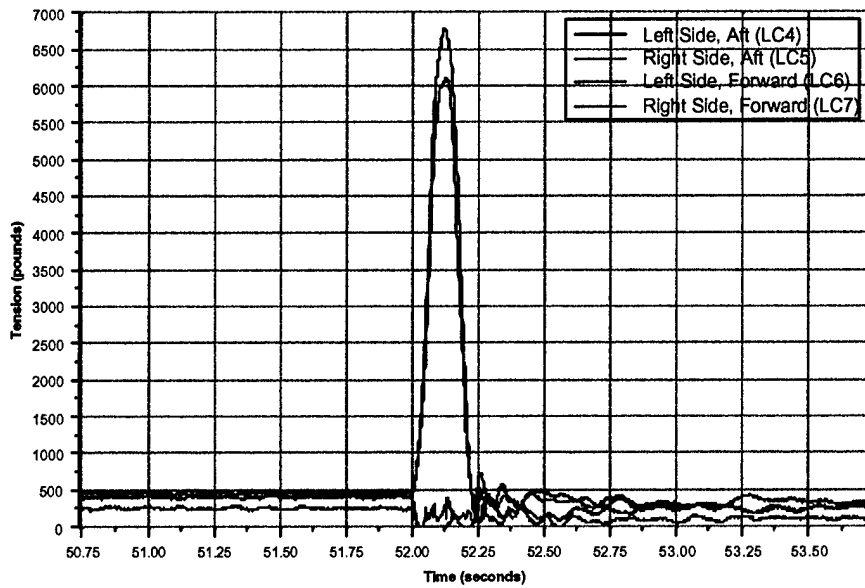

LOAD 2 - RAIL IMPACT 1 - 8.48 MPH - Load Cell 4

Forward Impact,
Left Side, Att.

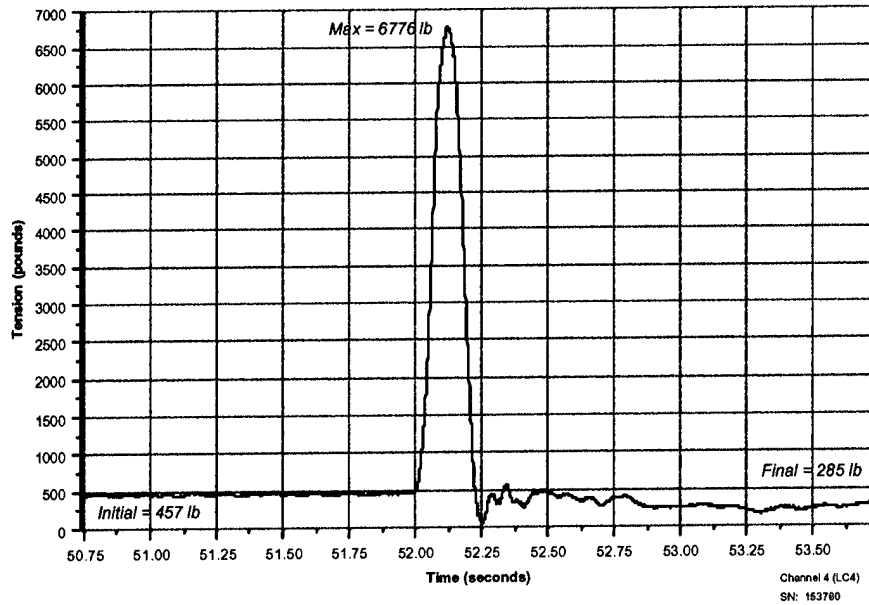

LOAD 2 - RAIL IMPACT 1 - 8.48 MPH - Load Cell 5

Forward Impact,
Right Side, Att.

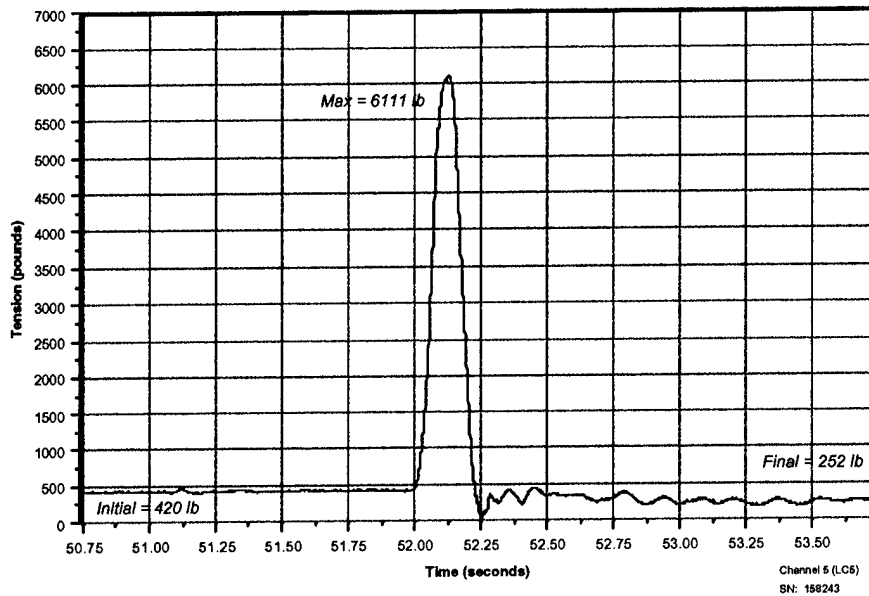

LOAD 2 - RAIL IMPACT 1 - 8.48 MPH - Load Cell 6

Forward Impact,
Left Side, Forward.

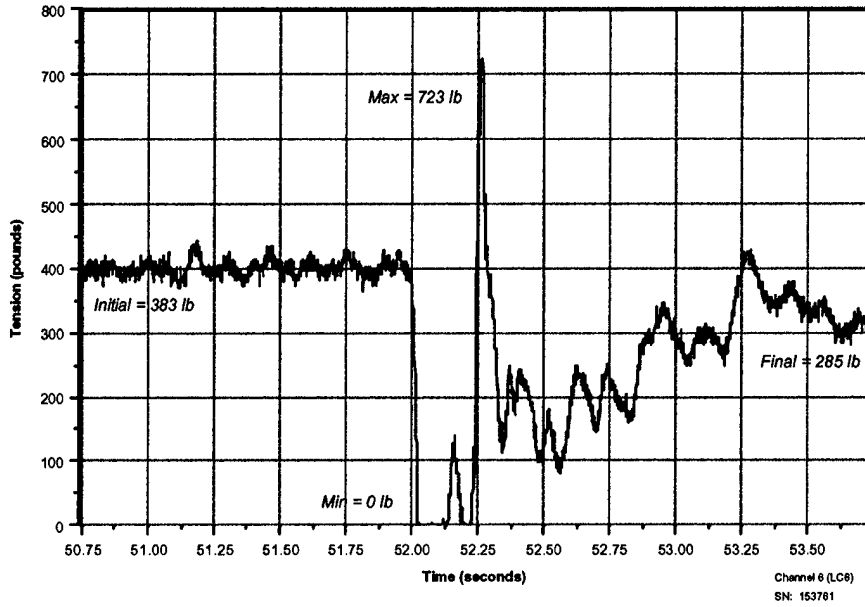

LOAD 2 - RAIL IMPACT 1 - 8.48 MPH - Load Cell 7

Forward Impact,
Right Side, Forward.

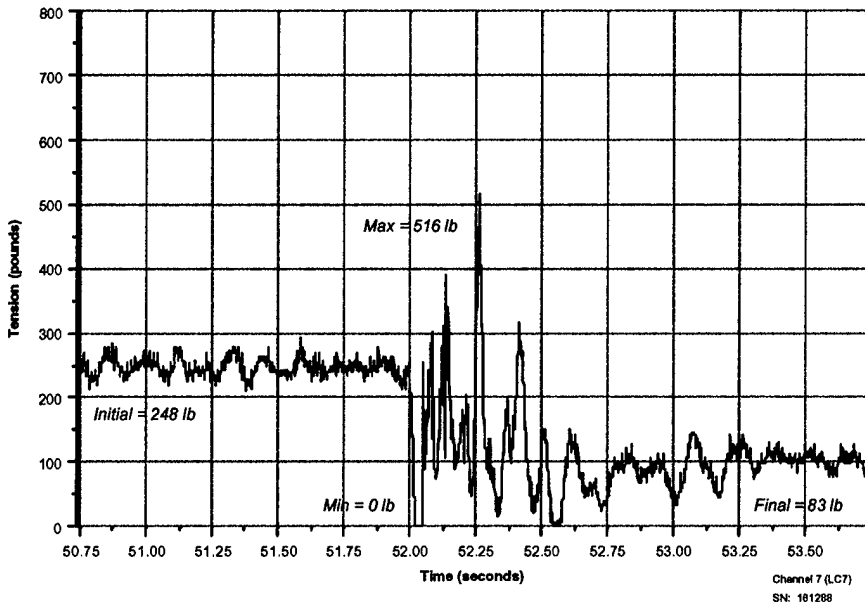

LOAD 2 - RAIL IMPACT 1 - 9.14 MPH - Load Cells 4, 5, 6, and 7

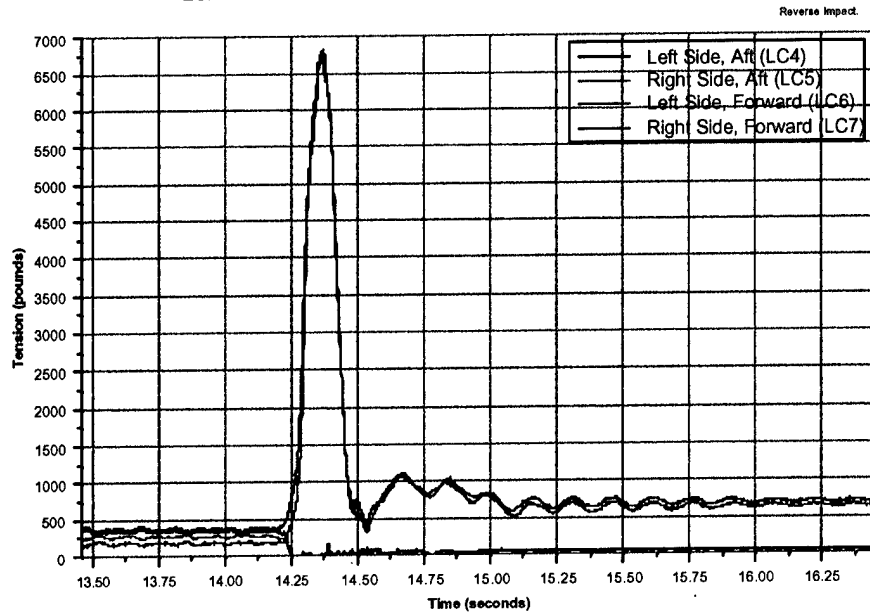

LOAD 2 - RAIL IMPACT 1 - 9.14 MPH - Load Cell 4

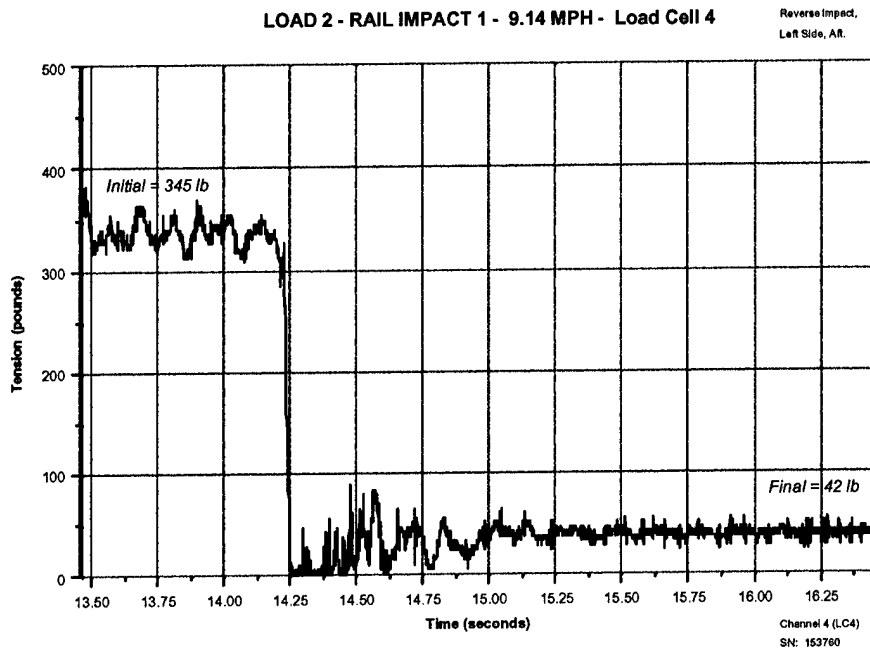

LOAD 2 - RAIL IMPACT 1 - 9.14 MPH - Load Cell 5

Reverse Impact,
Right Side, Aft.

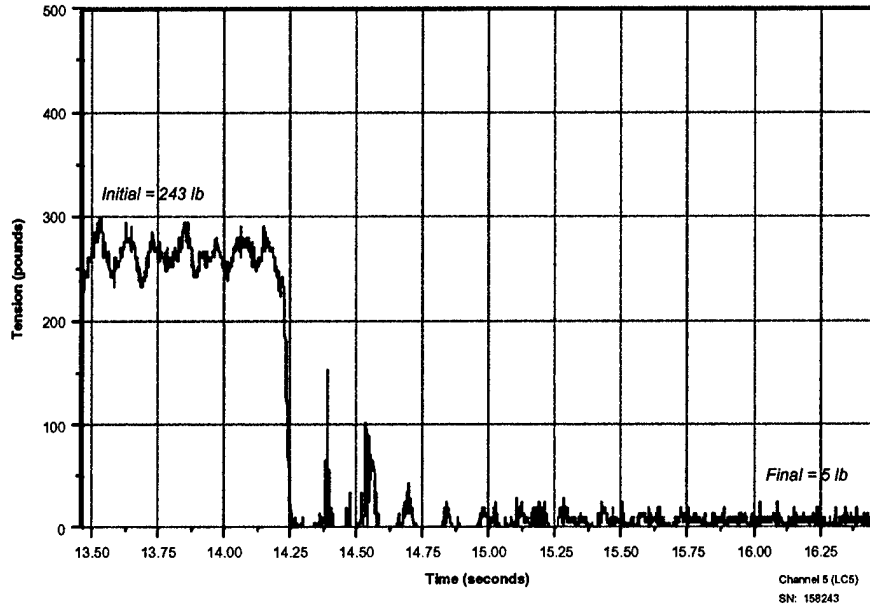

LOAD 2 - RAIL IMPACT 1 - 9.14 MPH - Load Cell 6

Reverse Impact,
Left Side, Forward.

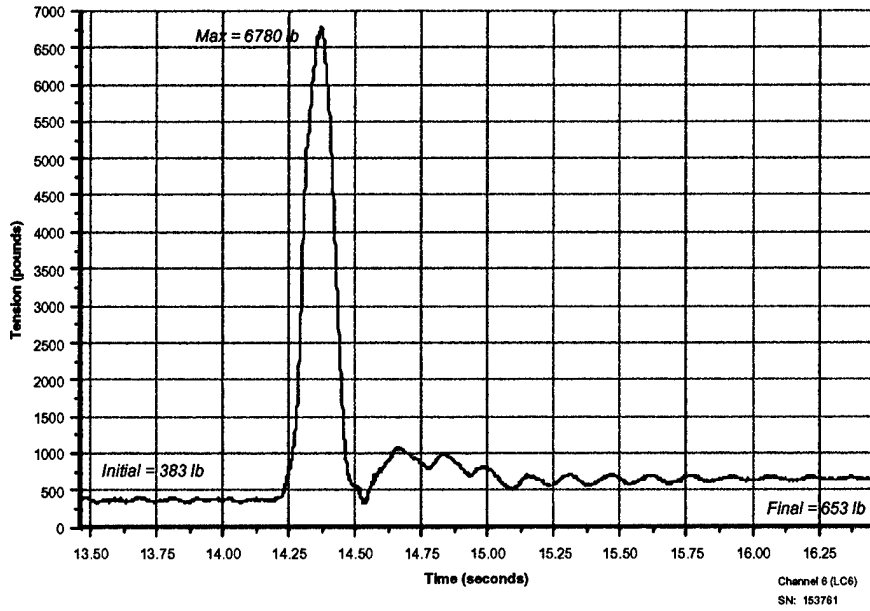

LOAD 2 - RAIL IMPACT 1 - 9.14 MPH - Load Cell 7

Reverse Impact,
Right Side, Forward.

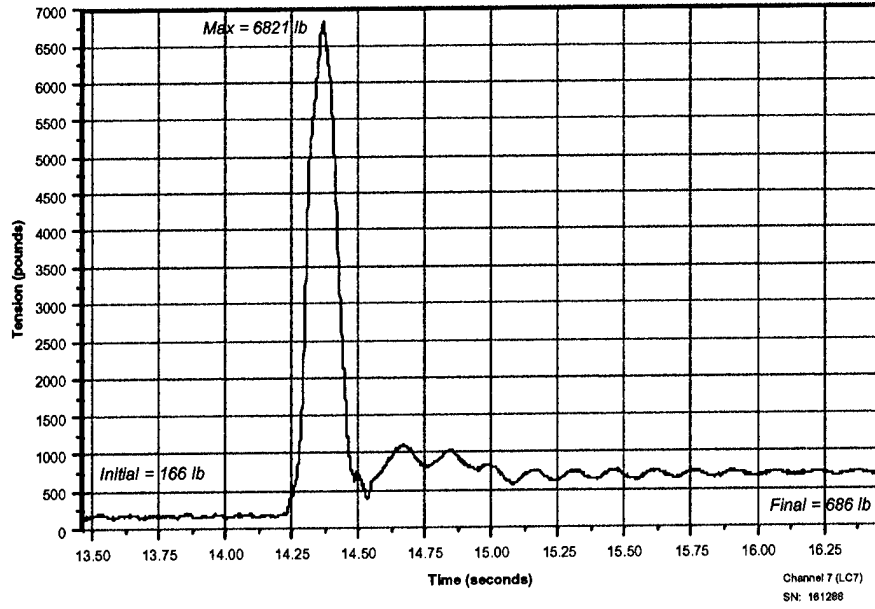

LOAD 2 - HAZARD PASS 2 - Load Cell 4

Left Side, Alt.

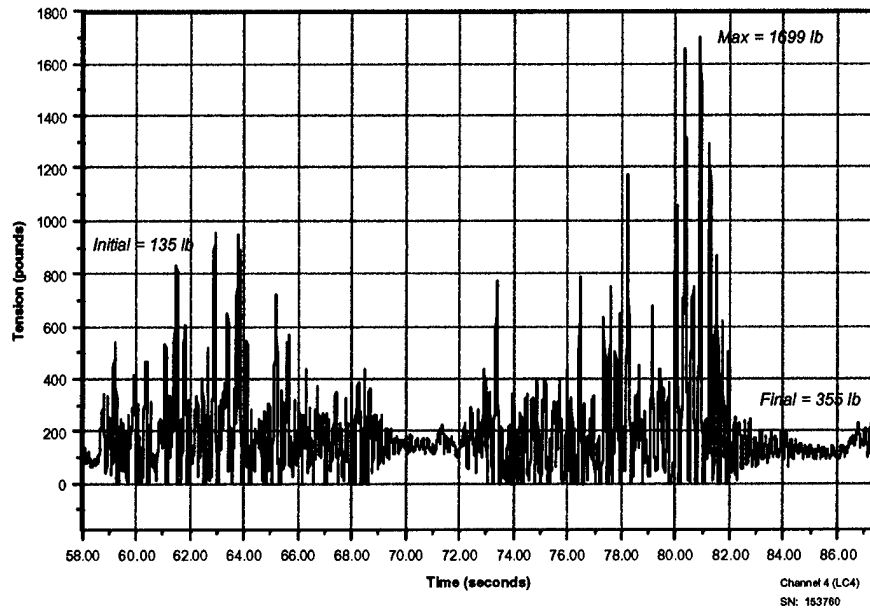

LOAD 2 - HAZARD PASS 2 - Load Cell 5

Right Side, Alt.

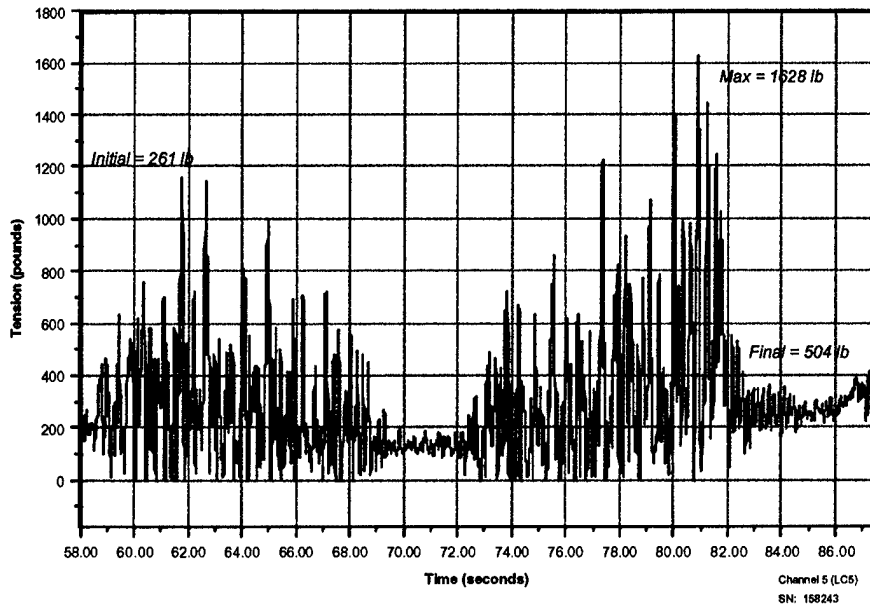

LOAD 2 - HAZARD PASS 2 - Load Cell 6

Left Side, Forward.

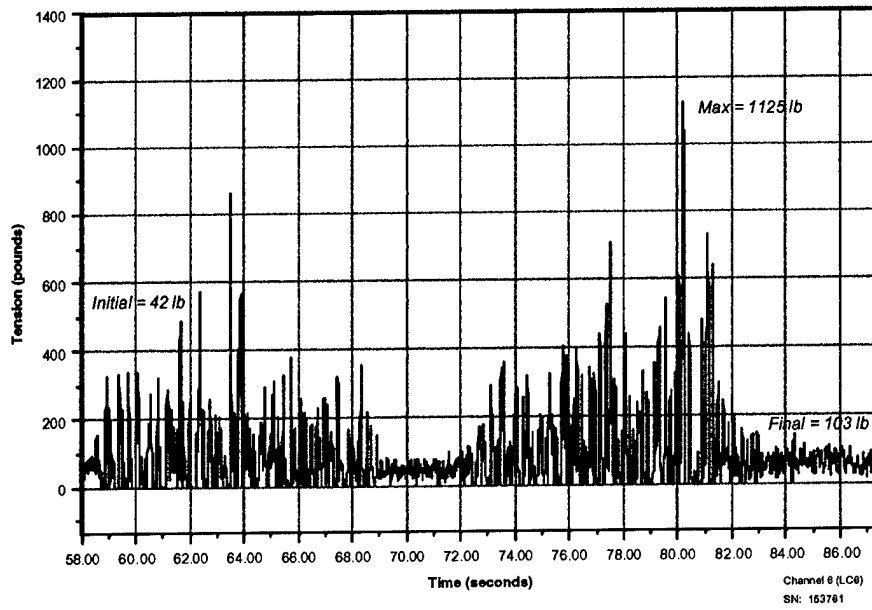

LOAD 2 - HAZARD PASS 2 - Load Cell 7

Right Side, Forward.

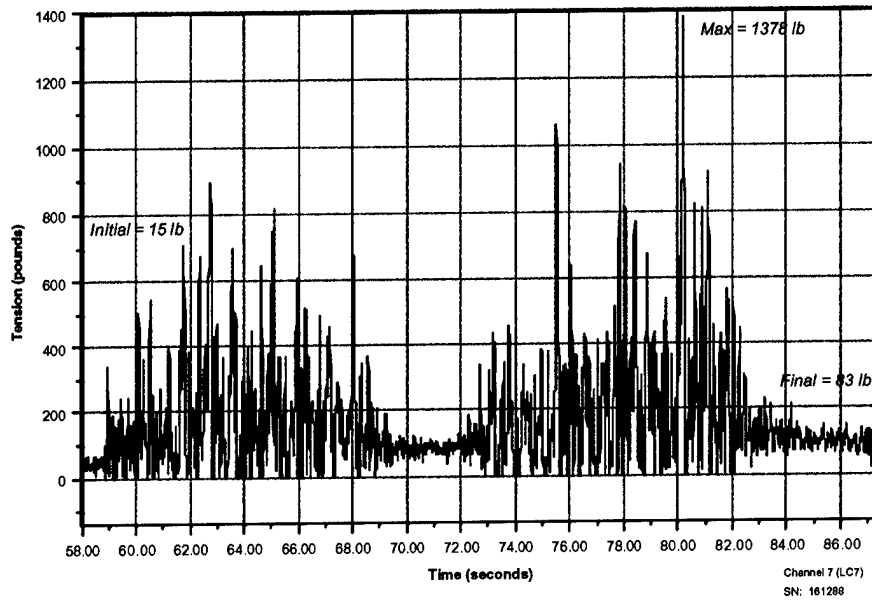

LOAD 2 - HAZARD PASS 3 - Load Cell 4

Left Side, Aft.

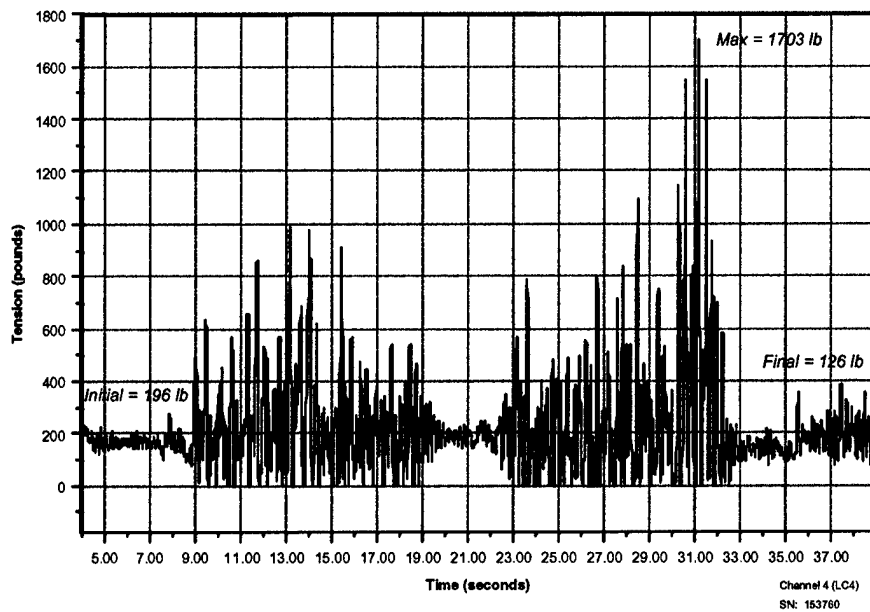

LOAD 2 - HAZARD PASS 3 - Load Cell 5

Right Side, Aft.

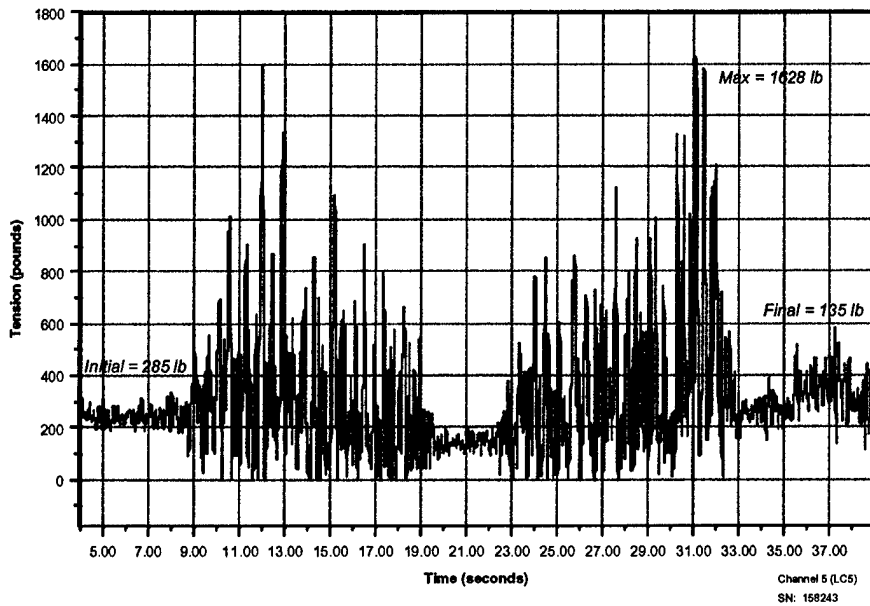

LOAD 2 - HAZARD PASS 3 - Load Cell 6

Left Side, Forward.

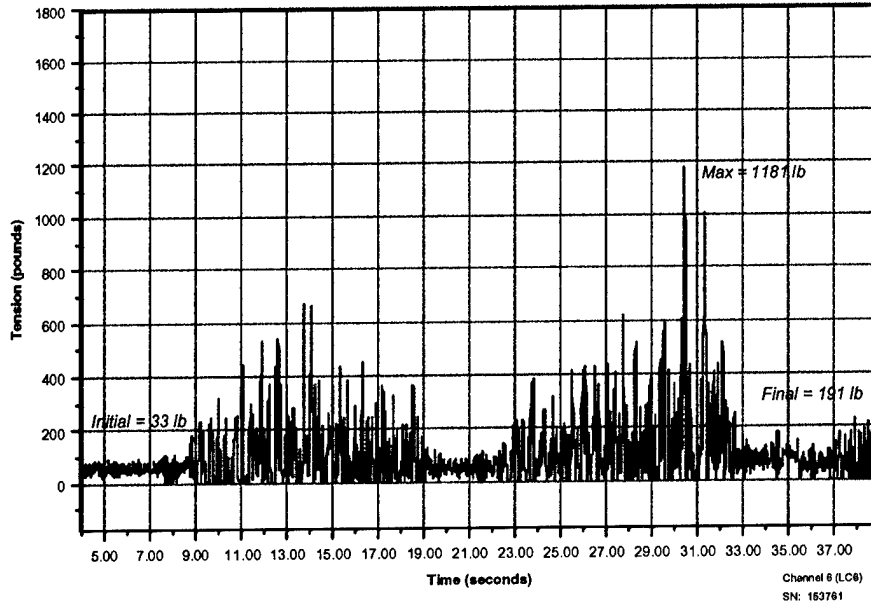

LOAD 2 - HAZARD PASS 3 - Load Cell 7

Right Side, Forward.

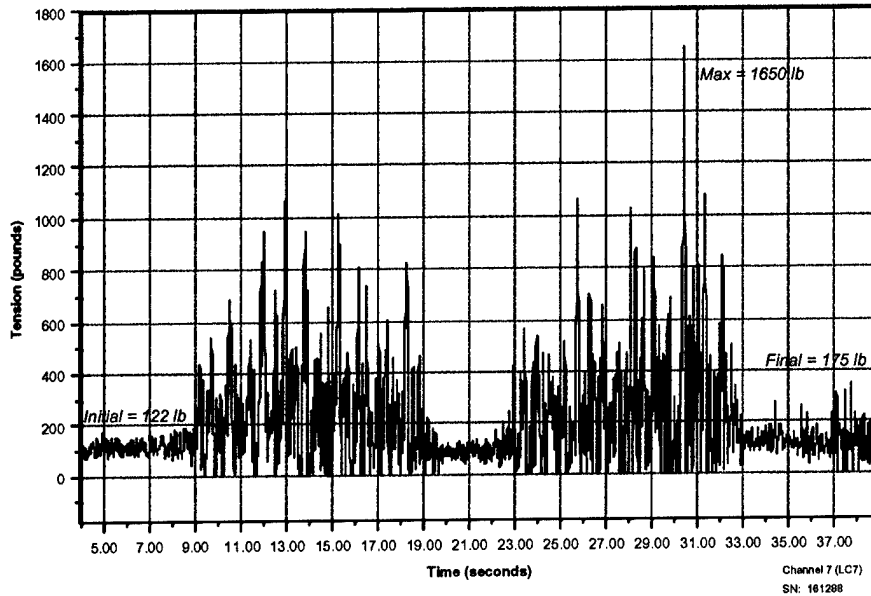

LOAD 2 - HAZARD PASS 4 - Load Cell 4

Left Side, Alt.

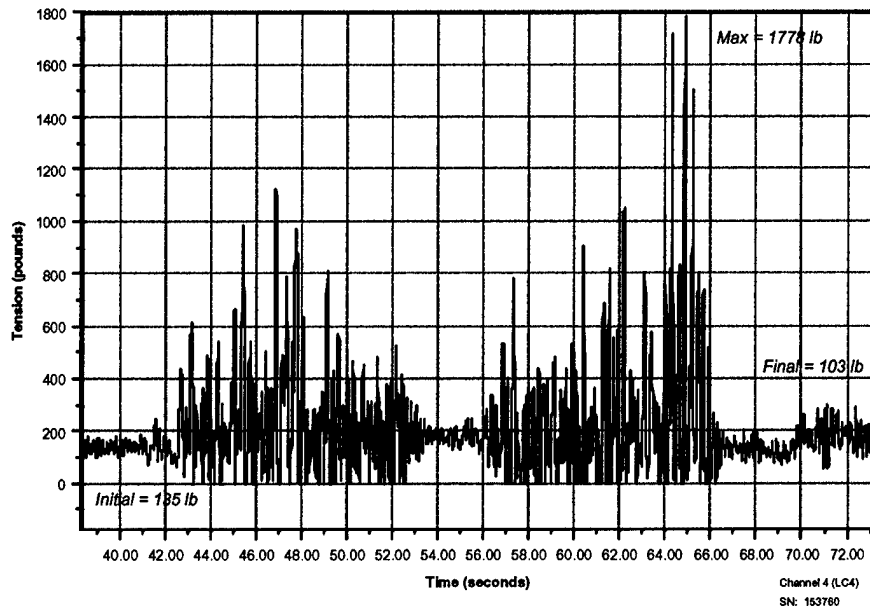

LOAD 2 - HAZARD PASS 4 - Load Cell 5

Right Side, Alt.

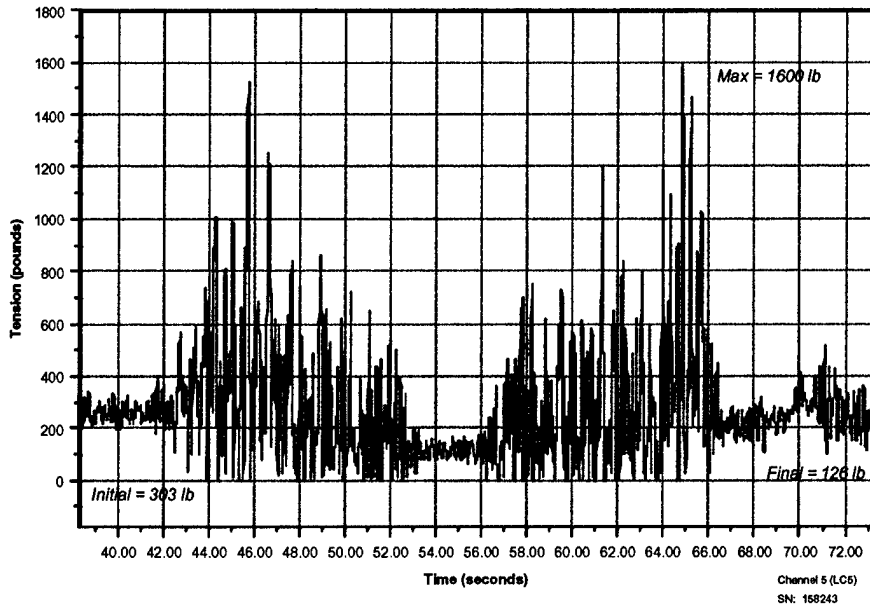

LOAD 2 - HAZARD PASS 4 - Load Cell 6

Left Side, Forward.

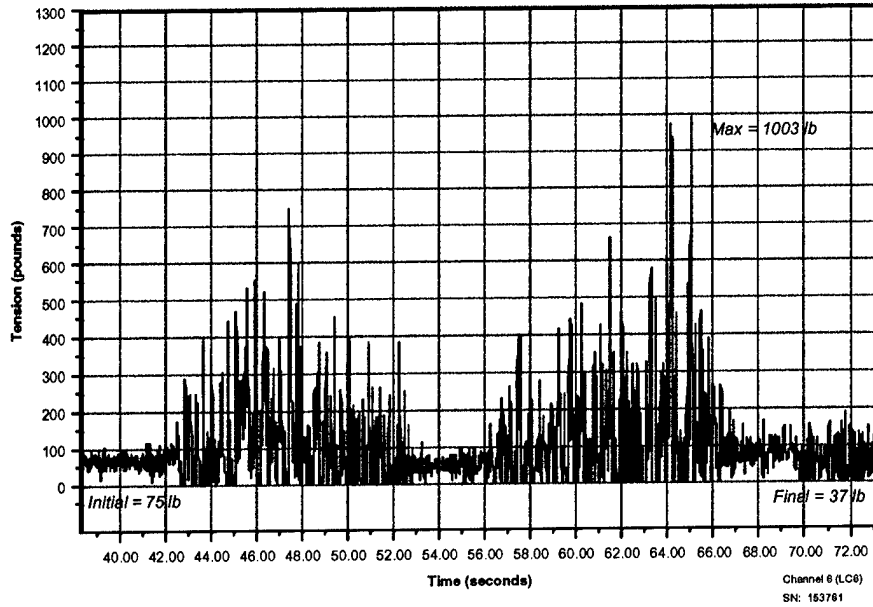

LOAD 2 - HAZARD PASS 4- Load Cell 7

Right Side, Forward.

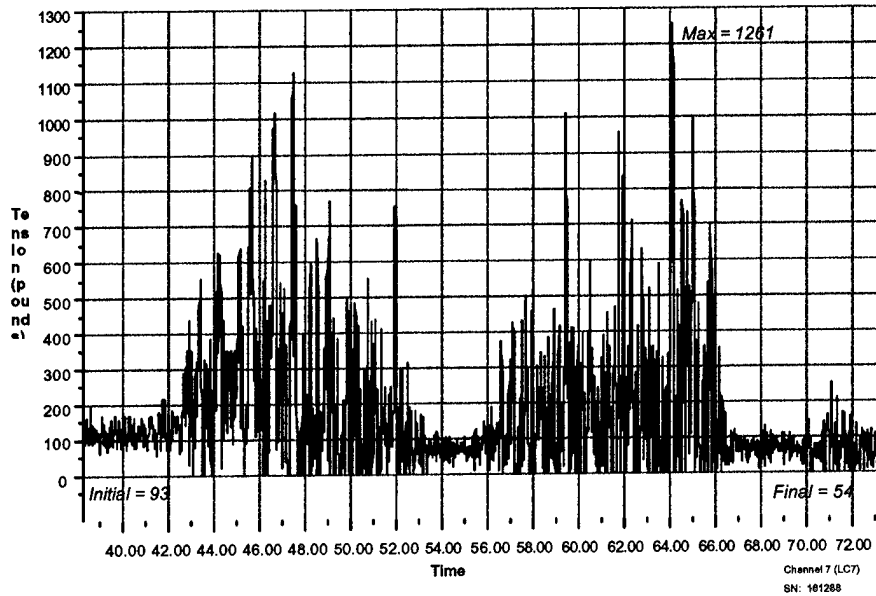

LOAD 2 - RAIL IMPACT 2 - 4.25 MPH - Load Cells 4, 5, 6, and 7

Forward Impact.

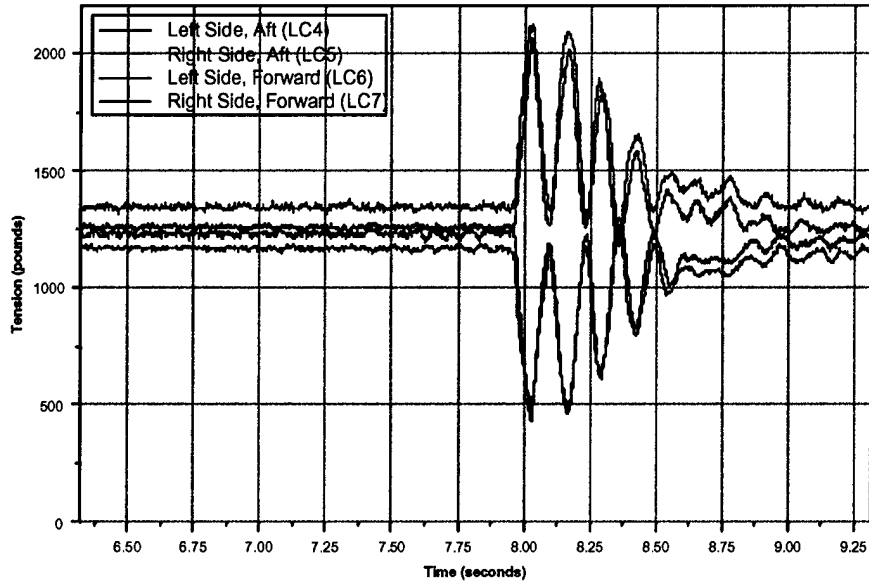

LOAD 2 - RAIL IMPACT 2 - 4.25 MPH - Load Cell 4

Forward Impact.
Left Side, Aft.

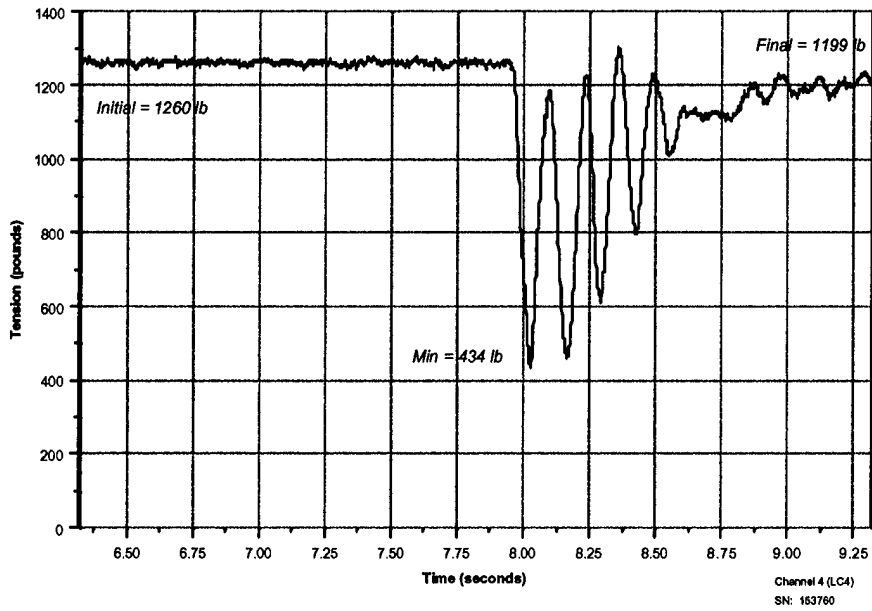

LOAD 2 - RAIL IMPACT 2 - 4.25 MPH - Load Cell 5

Forward Impact,
Right Side, AR.

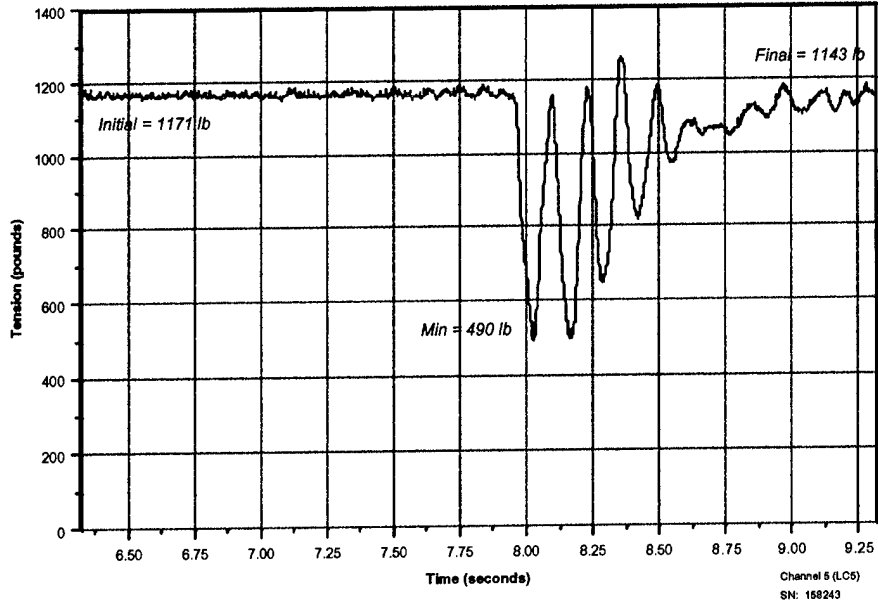

LOAD 2 - RAIL IMPACT 2 - 4.25 MPH - Load Cell 6

Forward Impact,
Left Side, Forward.

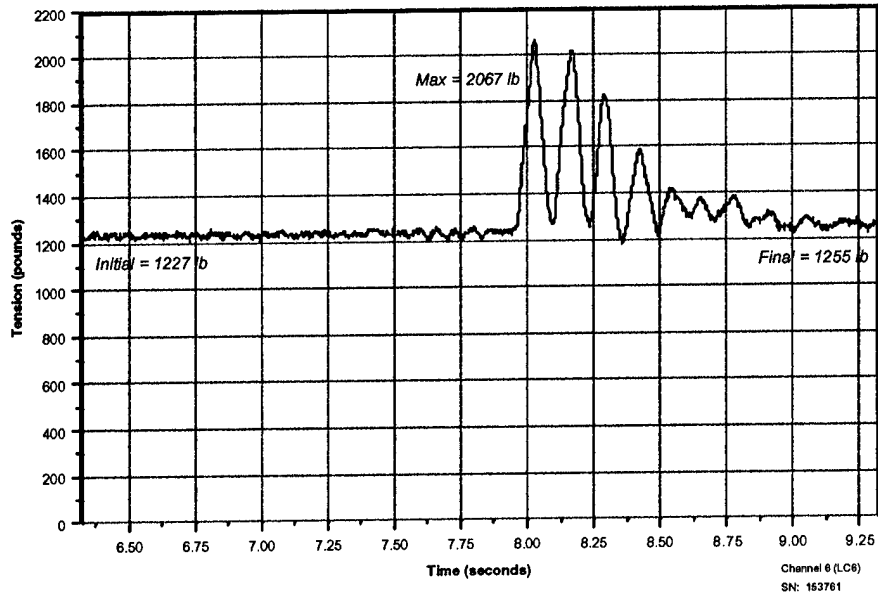

LOAD 2 - RAIL IMPACT 2 - 4.25 MPH - Load Cell 7

Forward Impact,
Right Side, Forward.

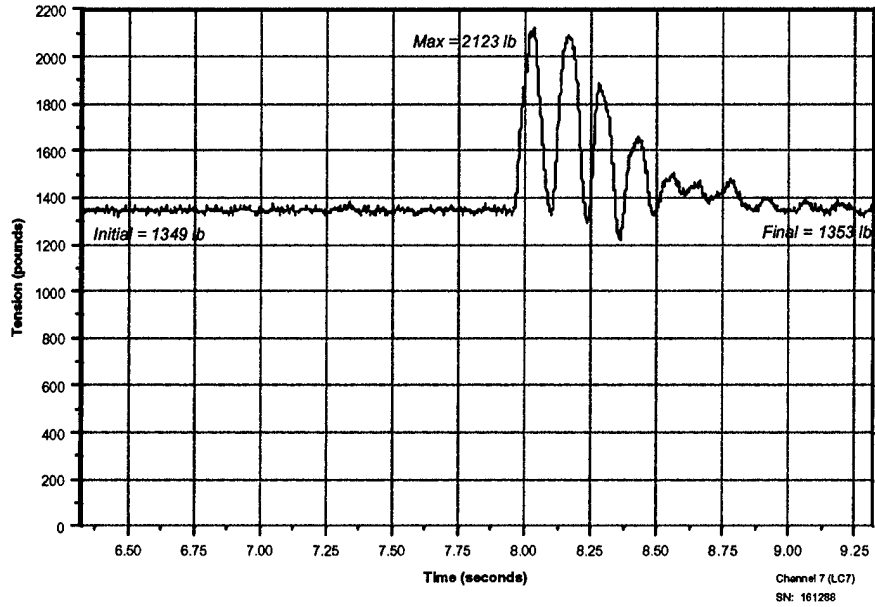

LOAD 2 - RAIL IMPACT 2 - 6.31 MPH - Load Cells 4, 5, 6, and 7

Forward Impact.

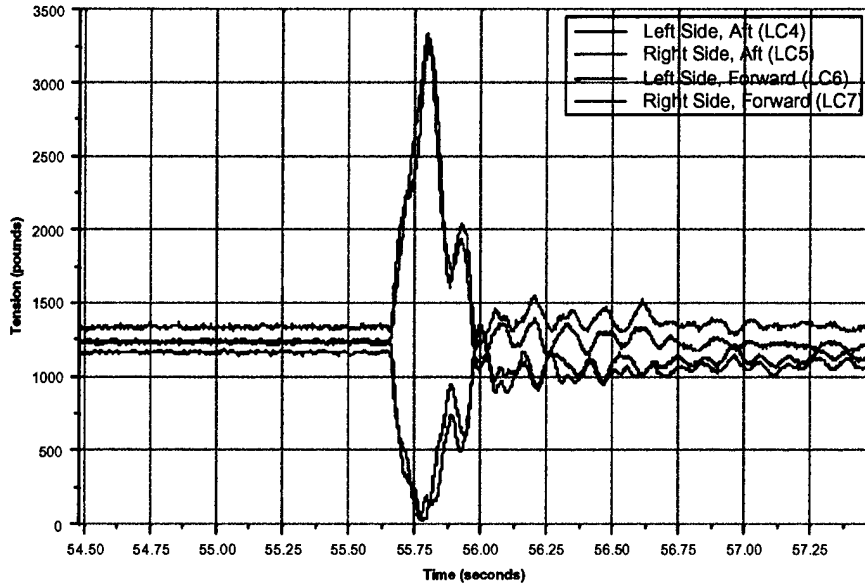

LOAD 2 - RAIL IMPACT 2 - 6.31 MPH - Load Cell 4

Forward Impact,
Left Side, Aft.

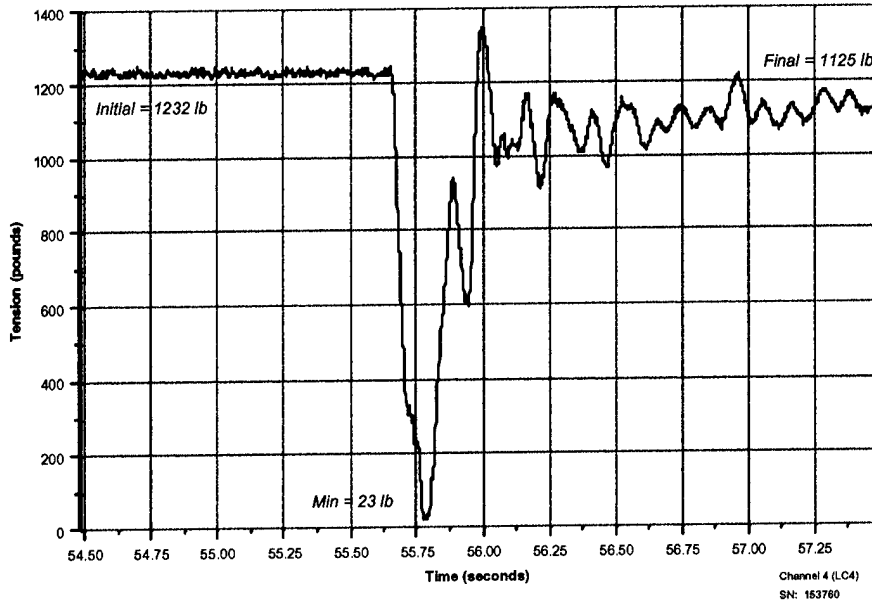

LOAD 2 - RAIL IMPACT 2 - 6.31 MPH - Load Cell 5

Forward Impact,
Right Side, Aft.

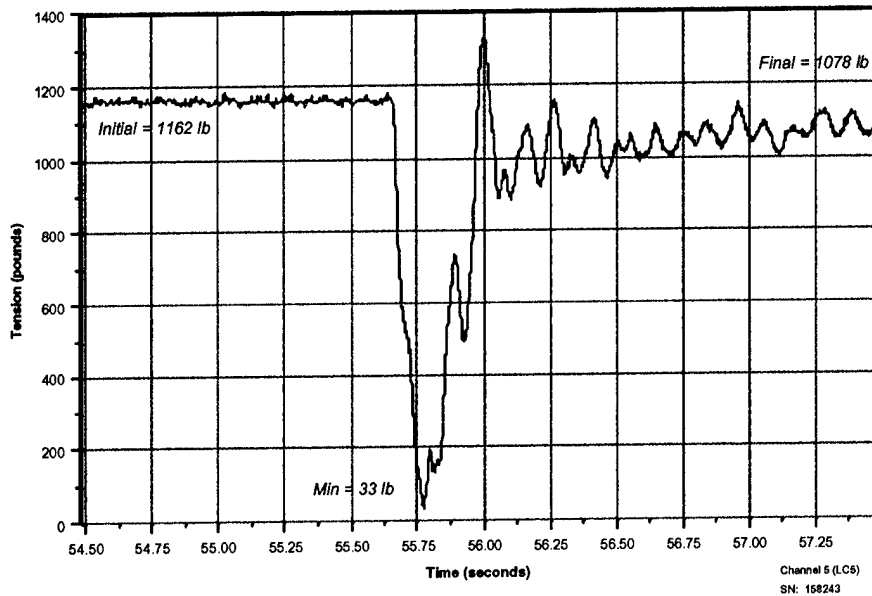

LOAD 2 - RAIL IMPACT 2 - 6.31 MPH - Load Cell 6

Forward Impact,
Left Side, Forward.

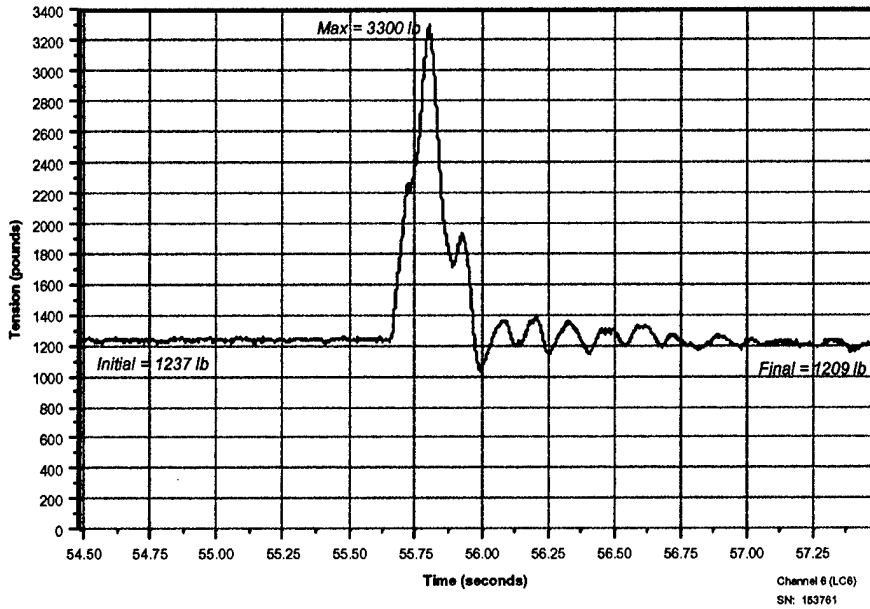

LOAD 2 - RAIL IMPACT 2 - 6.31 MPH - Load Cell 7

Forward Impact,
Right Side, Forward.

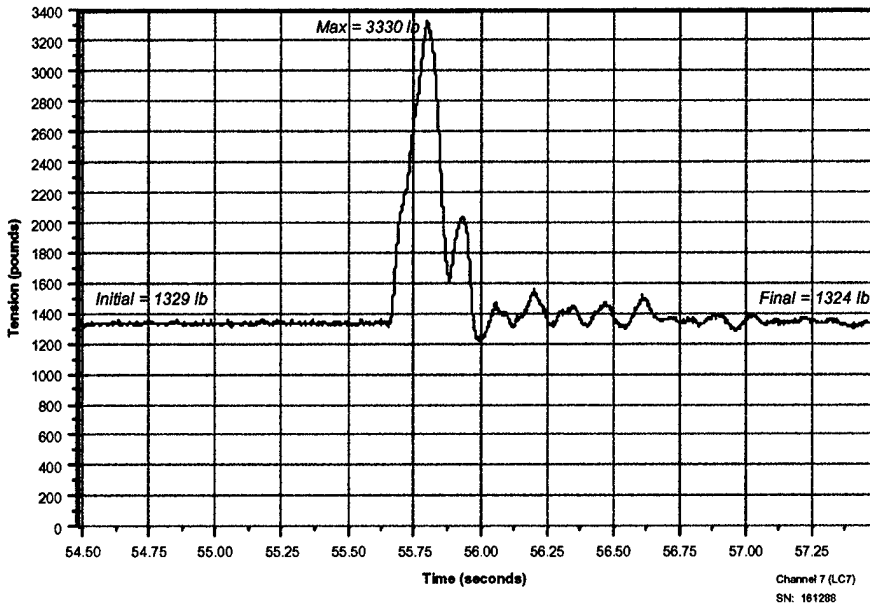

LOAD 2 - RAIL IMPACT 2 - 8.31 MPH - Load Cells 4, 5, 6, and 7

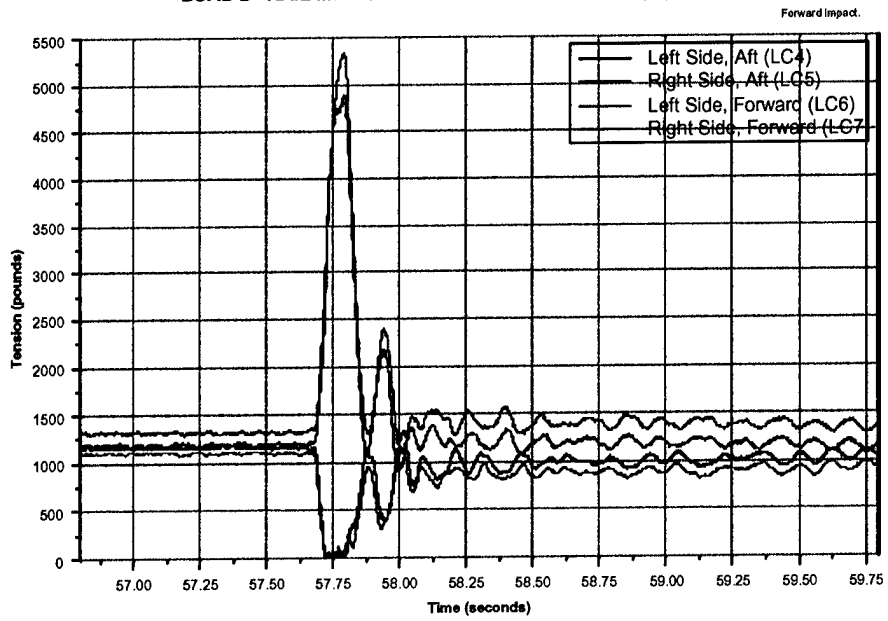

LOAD 2 - RAIL IMPACT 2 - 8.31 MPH - Load Cell 4

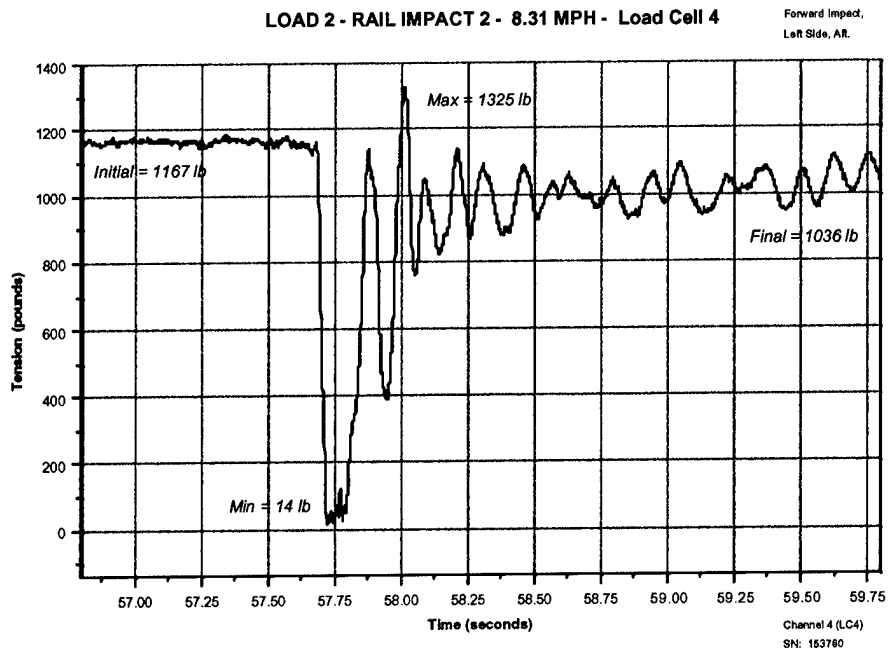

LOAD 2 - RAIL IMPACT 2 - 8.31 MPH - Load Cell 5

Forward Impact,
Right Side, Aft.

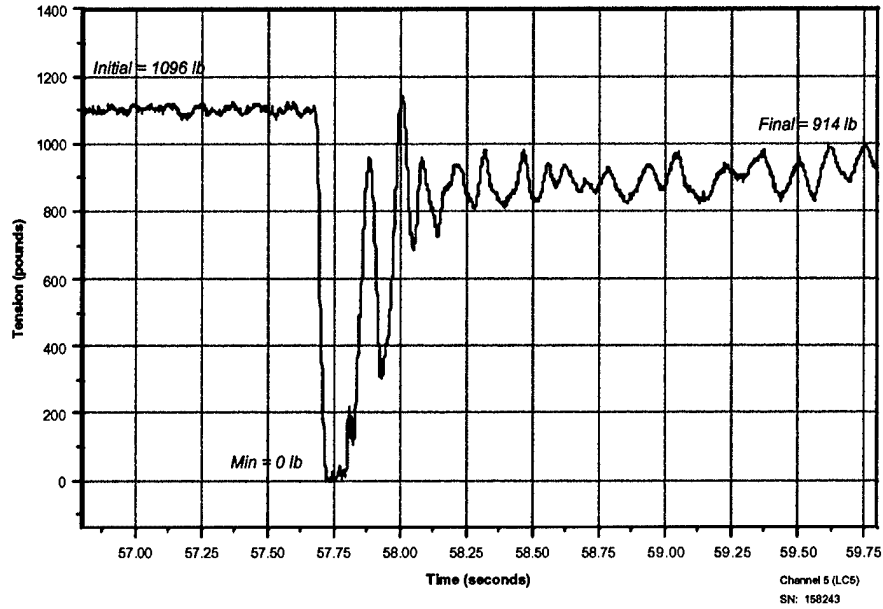

LOAD 2 - RAIL IMPACT 2 - 8.31 MPH - Load Cell 6

Forward Impact,
Left Side, Forward.

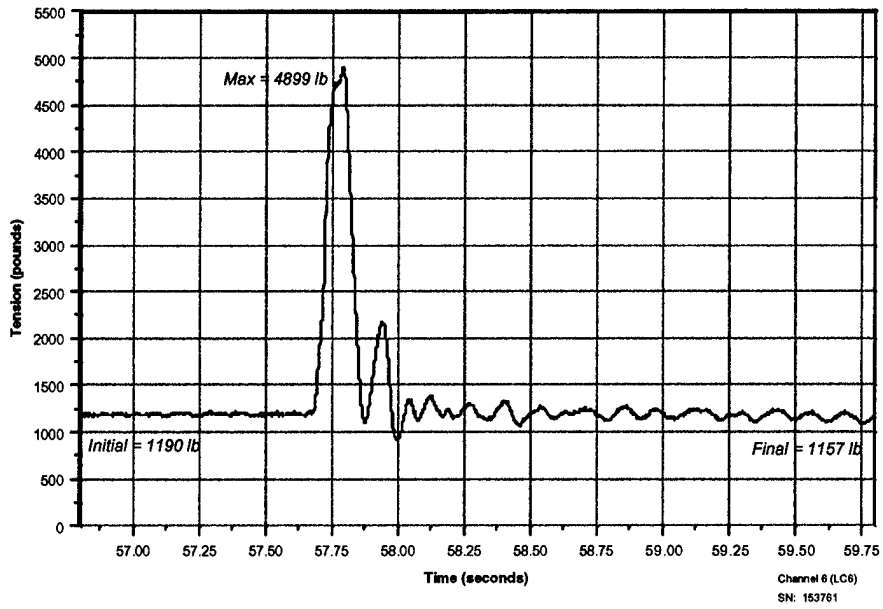

LOAD 2 - RAIL IMPACT 2 - 8.31 MPH - Load Cell 7

Forward Impact,
Right Side, Forward.

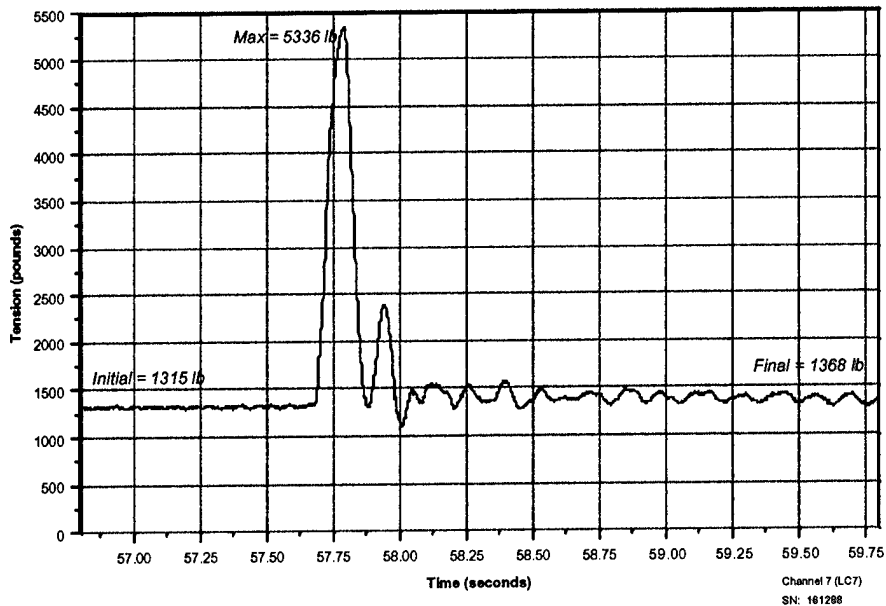

LOAD 2 - RAIL IMPACT 2 - 8.37 MPH - Load Cells 4, 5, 6, and 7

Reverse Impact.

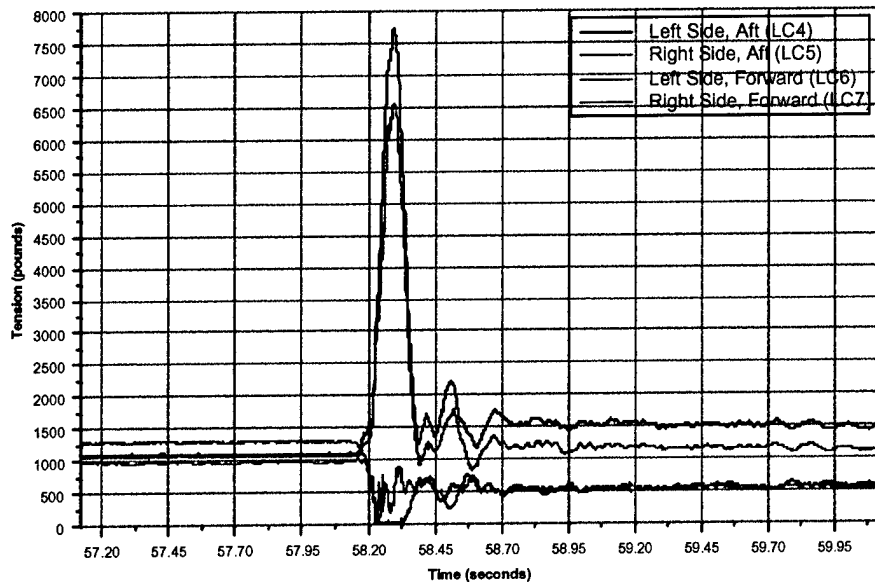

LOAD 2 - RAIL IMPACT 2 - 8.37 MPH - Load Cell 4

Reverse Impact,
Left Side, Aft.

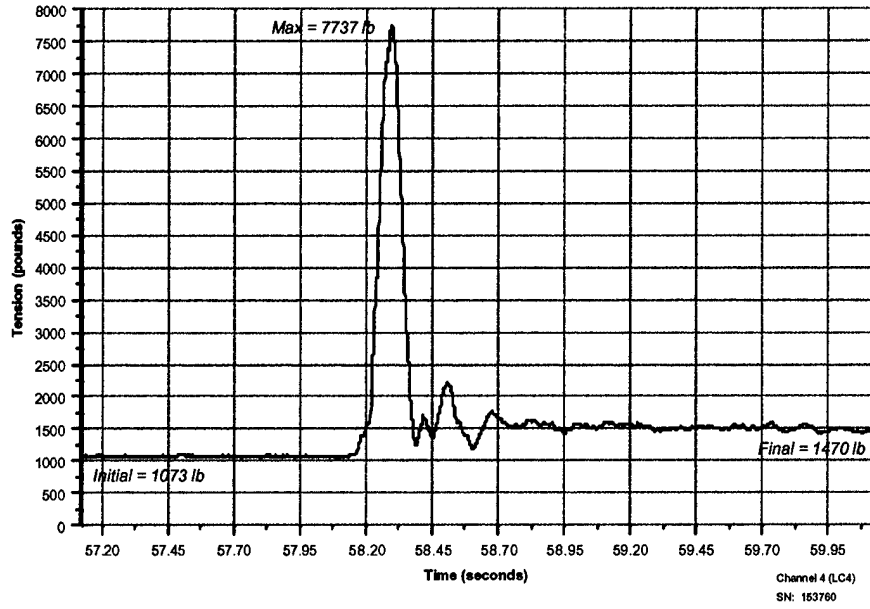

LOAD 2 - RAIL IMPACT 2 - 8.37 MPH - Load Cell 5

Reverse Impact,
Right Side, Aft.

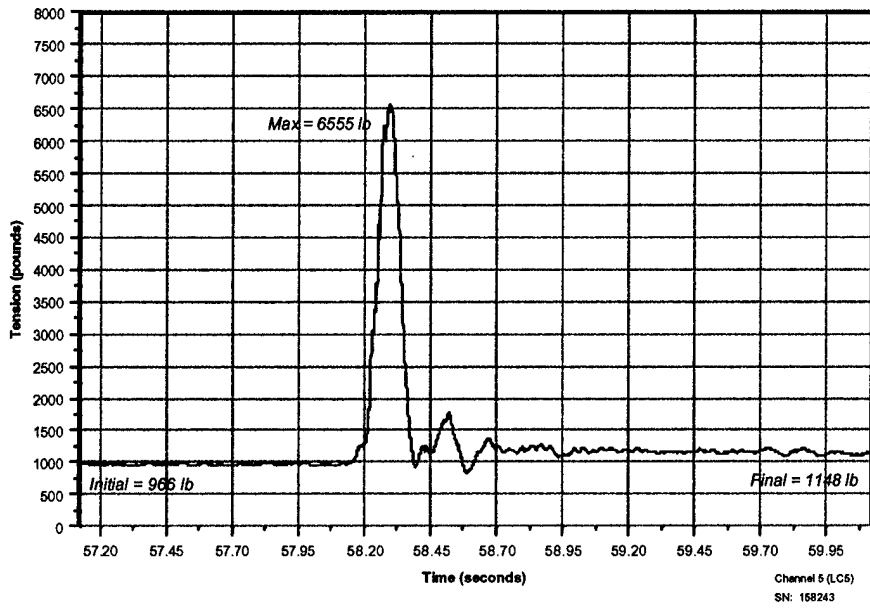

LOAD 2 - RAIL IMPACT 2 - 8.37 MPH - Load Cell 6

Reverse Impact,
Left Side, Forward.

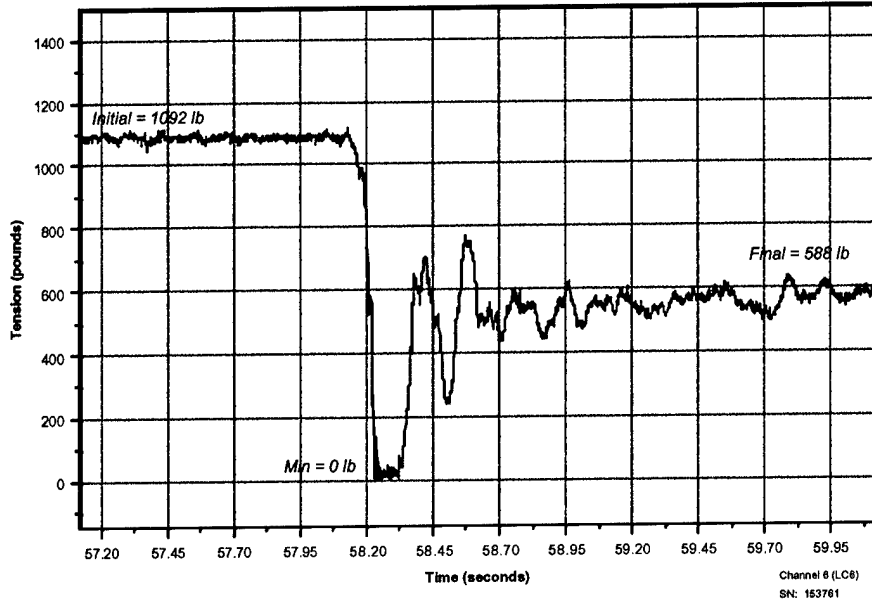

LOAD 2 - RAIL IMPACT 2 - 8.37 MPH - Load Cell 7

Reverse Impact,
Right Side, Forward.

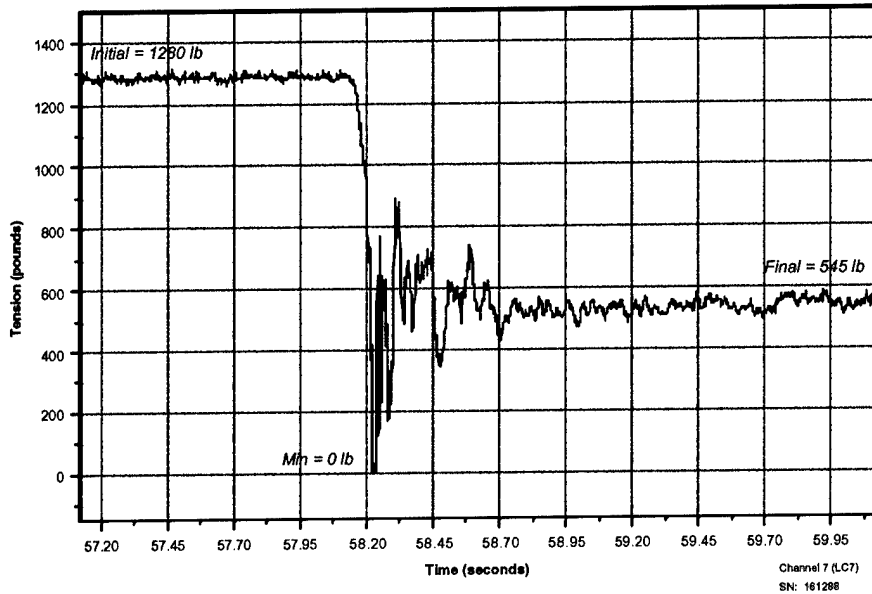

PART 7 – DRAWINGS

The following drawings represent the load configurations that were subjected to the test criteria.

4/11/01

APPROVED BY
BUREAU OF EXPLOSIVES

0-12

DATE 1/11/01

APPENDIX 2

LOADING AND BRACING PROCEDURES FOR STRATEGIC CONFIGURED LOAD (SCL) ON CONTAINER ROLL IN/OUT PLATFORM (CROP) - SCL #2

120MM HEAT-MP-T & APFSDS-T

INDEX

ITEM	PAGE(S)
TYPICAL LOADING PROCEDURES - - - - -	2
GENERAL NOTES AND SEQUENTIAL LOADING PROCEDURES - - - - -	3
PALLET UNIT DETAILS - - - - -	4-6
DETAILS - - - - -	7-10

NOTICE: THIS APPENDIX CANNOT STAND ALONE BUT MUST BE USED IN CONJUNCTION WITH THE BASIC CROP OUTLOADING PROCEDURES DRAWING 19-48-4905-CA17Q6.

- LOADING AND BRACING SPECIFICATIONS SET FORTH WITHIN THIS DRAWING ARE APPLICABLE TO LOADS THAT ARE TO BE SHIPPED BY TRAILER/CONTAINER-ON-FLATCAR (T/COFC) RAIL CARRIER SERVICE. THESE SPECIFICATIONS MAY ALSO BE USED FOR LOADS THAT ARE TO BE MOVED BY MOTOR OR WATER CARRIERS.

U.S. ARMY MATERIEL COMMAND DRAWING

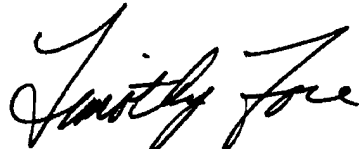
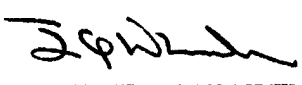
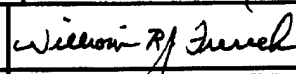
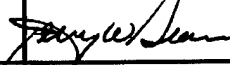
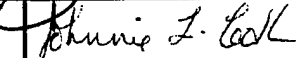
APPROVED, U.S. ARMY OPERATIONS SUPPORT COMMAND 	ENGINEER	BASIC	RICHARD GARSIDE	DO NOT SCALE				
		REV.		WEBSITE: HTTP://WWW.DAC.ARMY.MIL				
	TECHNICIAN	BASIC		DECEMBER 2000				
	REV.							
	DRAFTSMAN	BASIC						
		REV.						
APPROVED BY ORDER OF COMMANDING GENERAL, U.S. ARMY MATERIEL COMMAND  U.S. ARMY DEFENSE AMMUNITION CENTER	TRANSPORTATION ENGINEERING DIVISION							
	VALIDATION ENGINEERING DIVISION			TESTED	CLASS	DIVISION	DRAWING	FILE
	ENGINEERING DIRECTORATE				19	48	4905/ 2	CA17Q6

PROJECT CAP-TV 6/2-00

NOTE: POSITION PALLETS WITH OPENING
END OF CONTAINERS FACING OUTWARDS.

FORWARD END
OF CROP.

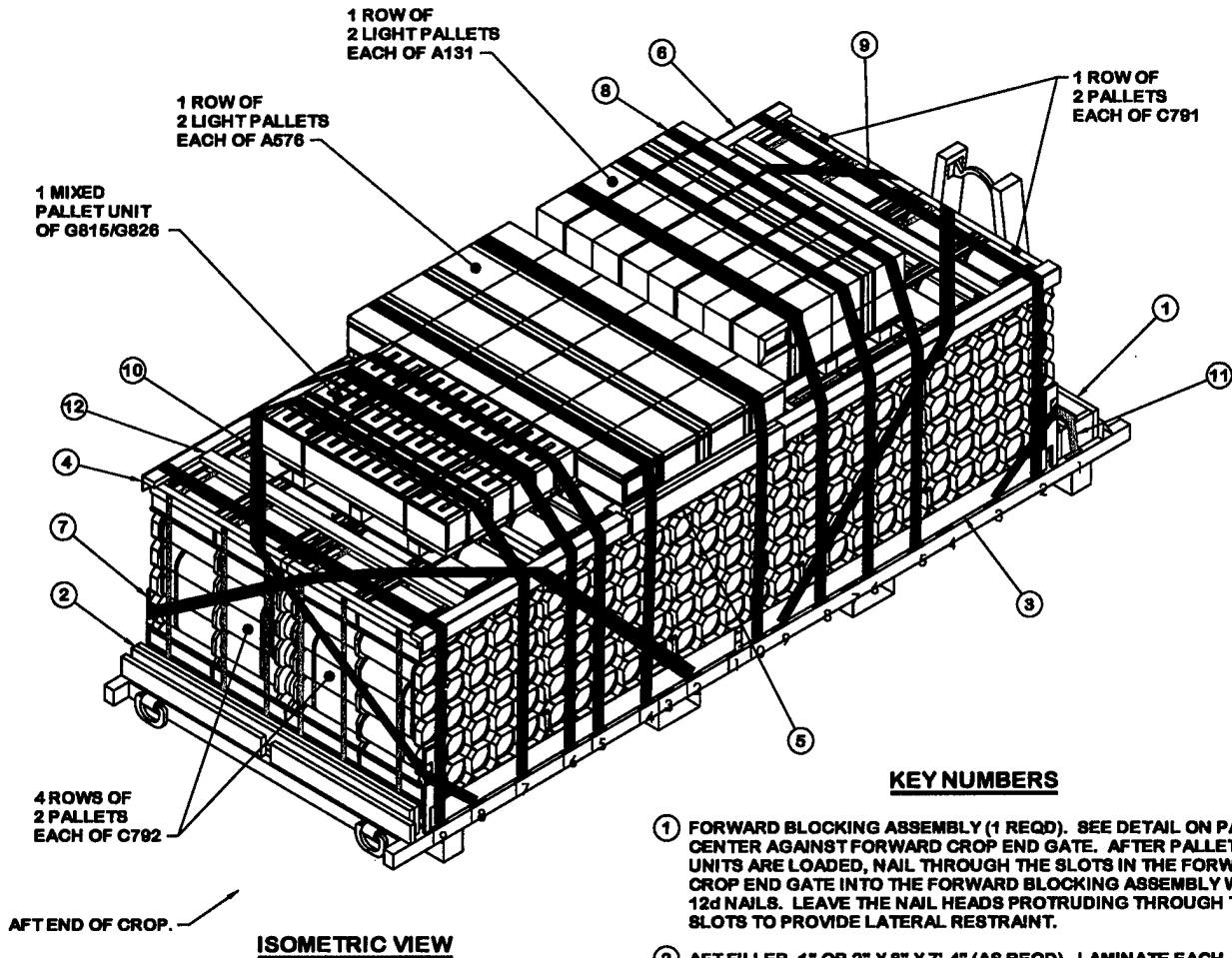

ISOMETRIC VIEW

KEY NUMBERS

(KEY NUMBERS CONTINUED)

- ⑨ FORWARD END RESTRAINT STRAP, 3-INCH WIDE CROP STRAP (2 REQD). INSTALL EACH STRAP TO EXTEND FROM THE THIRD TIEDOWN ANCHOR ON ONE SIDE OF CROP, AROUND THE SIDE OF THE FORWARD C791 PALLET UNITS, OVER THE TOP OF THE FORWARD C791 PALLET UNITS, TO THE NINTH TIEDOWN ANCHOR ON THE OPPOSITE SIDE OF THE CROP. ALIGN SCUFF SLEEVES OVER ALL SHARP EDGES AND FIRMLY TENSION STRAP. SEE GENERAL NOTE "H" ON PAGE 3.
- ⑩ AFT END RESTRAINT STRAP, 3-INCH WIDE CROP STRAP (2 REQD). INSTALL EACH STRAP TO EXTEND FROM THE EIGHTEENTH TIEDOWN ANCHOR ON ONE SIDE OF CROP, AROUND THE SIDE OF THE AFT C792 PALLET UNITS, OVER THE TOP OF THE AFT C792 PALLET UNITS, TO THE TWELFTH TIEDOWN ANCHOR ON THE OPPOSITE SIDE OF THE CROP. ALIGN SCUFF SLEEVES OVER ALL SHARP EDGES AND FIRMLY TENSION STRAP. SEE GENERAL NOTE "H" ON PAGE 3.
- ⑪ RETAINER STRAP, 2-INCH WIDE WEB 8 STRAP ASSEMBLY (1 REQD). INSTALL TO EXTEND FROM THE FIRST TIEDOWN ANCHOR ON ONE SIDE OF CROP, OVER TOP OF THE FORWARD BLOCKING ASSEMBLY STRAPPING BOARD, TO THE FIRST TIEDOWN ANCHOR ON OPPOSITE SIDE OF CROP. ALIGN SCUFF SLEEVES OVER ALL SHARP EDGES AND FIRMLY TENSION STRAP. SEE GENERAL NOTE "H" ON PAGE 3.
- ⑫ STRAPPING BOARD STRUT, 2" X 4" X 6'-9 1/4" (2 REQD). INSTALL ACROSS TOP OF C791 AND C792 PALLET UNITS, 14 1/4" FROM END OF STRAPPING BOARD ASSEMBLIES. TOE NAIL EACH END OF STRUT TO STRAPPING BOARD ASSEMBLIES WITH 2-10d NAILS.

- ① FORWARD BLOCKING ASSEMBLY (1 REQD). SEE DETAIL ON PAGE 5. CENTER AGAINST FORWARD CROP END GATE. AFTER PALLET UNITS ARE LOADED, NAIL THROUGH THE SLOTS IN THE FORWARD CROP END GATE INTO THE FORWARD BLOCKING ASSEMBLY W/2-12d NAILS. LEAVE THE NAIL HEADS PROTRUDING THROUGH THE SLOTS TO PROVIDE LATERAL RESTRAINT.
- ② AFT FILLER, 1" OR 2" X 8" X 7'-4" (AS REQD). LAMINATE EACH PIECE TO THE PREVIOUS PIECE W/8 NAILS OF A SUITABLE SIZE (6d NAILS FOR 1" THICK MATERIAL OR 10d NAILS FOR 2" THICK MATERIAL). CENTER AGAINST AFT CROP END GATE AND NAIL THROUGH THE SLOTS IN THE AFT CROP END GATE INTO THE AFT FILLER W/2-12d NAILS. LEAVE THE NAIL HEADS PROTRUDING THROUGH THE SLOTS TO PROVIDE LATERAL AND VERTICAL RESTRAINT.
- ③ SIDE BLOCKING ASSEMBLY (4 REQD). SEE DETAIL ON PAGE 8. INSTALL TWO ON EACH SIDE OF THE CROP ADJACENT TO THE C791 AND C792 PALLET UNITS.
- ④ AFT END STRAPPING BOARD ASSEMBLY (2 REQD). SEE THE DETAIL ON PAGE 7. INSTALL ONE ON EACH SIDE OF THE CROP, ON THE EDGES OF THE C792 PALLET UNITS, WITH END OF ASSEMBLY AGAINST BASE OF A576 PALLET UNIT.
- ⑤ SIDE STRAPPING BOARD ASSEMBLY (2 REQD). SEE THE DETAIL ON PAGE 8. INSTALL ONE ON EACH SIDE OF THE CROP, ON THE EDGES OF THE C792 PALLET UNITS.
- ⑥ FORWARD END STRAPPING BOARD ASSEMBLY (2 REQD). SEE THE DETAIL ON PAGE 7. INSTALL ONE ON EACH SIDE OF THE CROP, ON THE EDGES OF THE C791 AND C792 PALLET UNITS, WITH END OF ASSEMBLY AGAINST BASE OF A576 PALLET UNIT.
- ⑦ CORNER STRAPPING BOARD ASSEMBLY (4 REQD). SEE THE DETAIL ON PAGE 8. INSTALL TWO EACH OF ASSEMBLY A AND ASSEMBLY B, ON THE CORNERS OF THE C791 AND C792 PALLET UNITS, WITH BASE OF ASSEMBLY AGAINST DECK OF CROP AND BEARING PIECE ALONG SIDE OF LOAD.
- ⑧ HOLD-DOWN STRAP, 3-INCH WIDE CROP STRAP (10 REQD). INSTALL EACH STRAP TO EXTEND FROM THE DESIGNATED TIEDOWN ANCHOR ON ONE SIDE OF CROP, OVER THE TOP OF THE PALLET UNITS, TO THE CORRESPONDING TIEDOWN ANCHOR ON THE OPPOSITE SIDE OF THE CROP. ALIGN SCUFF SLEEVES OVER ALL SHARP EDGES AND FIRMLY TENSION STRAP. SEE GENERAL NOTE "H" ON PAGE 3.

(CONTINUED AT LEFT)

RECOMMENDED SEQUENTIAL PROCEDURES

1. PREFABRICATE FORWARD BLOCKING ASSEMBLY, TWO AFT END STRAPPING BOARD ASSEMBLIES, TWO FORWARD END STRAPPING BOARD ASSEMBLIES, TWO SIDE STRAPPING BOARD ASSEMBLIES, FOUR SIDE BLOCKING ASSEMBLIES, AND FOUR CORNER STRAPPING BOARD ASSEMBLIES (TWO OF ASSEMBLY A AND TWO OF ASSEMBLY B).
2. INSTALL FORWARD BLOCKING ASSEMBLY, AS NOTED IN KEY NUMBER ①. ALIGN STRAPPING BOARD TO FIRST TIEDOWN ANCHOR AND NAIL TO STRUTS. INSTALL RETAINER STRAP, AS NOTED IN KEY NUMBER ①.
3. LOAD ONE ROW OF TWO PALLET UNITS OF C791 AGAINST THE FORWARD BLOCKING ASSEMBLY, FOLLOWED BY FOUR ROWS OF TWO PALLET UNITS OF C792, CENTERING THE ROWS Laterally ON THE CROP AND POSITIONING TIGHT AGAINST THE ADJACENT PALLET UNITS.
4. INSTALL AFT FILLER PIECES TO A TIGHT FIT BETWEEN PALLET UNITS AND AFT CROP END GATE, AS NOTED IN KEY NUMBER ②.
5. LOAD ONE ROW OF TWO A576 LIGHT PALLET UNITS ON TOP OF THE C792 PALLET UNITS USING AFT END AND FORWARD END STRAPPING BOARD ASSEMBLIES TO POSITION PALLETS APPROPRIATE DISTANCE FROM ENDS OF LOAD, CENTERING THE ROW Laterally ON THE CROP.
6. LOAD ONE ROW OF TWO A131 LIGHT PALLET UNITS FORWARD AND THE G815/G826 LIGHT PALLET UNIT AFT OF THE ROW OF A576 LIGHT PALLET UNITS, CENTERING THE ROWS Laterally ON THE CROP AND POSITIONING TIGHT AGAINST THE ADJACENT PALLET UNITS.
7. INSTALL TWO SIDE STRAPPING BOARD ASSEMBLIES, AS NOTED IN KEY NUMBER ⑤.
8. INSTALL TWO AFT END STRAPPING BOARD ASSEMBLIES, AS NOTED IN KEY NUMBER ④.
9. INSTALL TWO FORWARD END STRAPPING BOARD ASSEMBLIES, AS NOTED IN KEY NUMBER ⑥.
10. INSTALL FOUR SIDE BLOCKING ASSEMBLIES, AS NOTED IN KEY NUMBER ③.
11. INSTALL FOUR CORNER STRAPPING BOARD ASSEMBLIES, AS NOTED IN KEY NUMBER ⑦.
12. INSTALL TWO STRAPPING BOARD STRUTS, AS NOTED IN KEY NUMBER ⑫.
13. INSTALL TEN HOLD-DOWN STRAPS, AS NOTED IN KEY NUMBER ⑧.
14. INSTALL TWO FORWARD END RESTRAINT STRAPS, AS NOTED IN KEY NUMBER ⑨.
15. INSTALL TWO AFT END RESTRAINT STRAPS, AS NOTED IN KEY NUMBER ⑩.
16. NAIL TWO 12d RETAINING NAILS THRU THE SLOTS IN THE AFT CROP END GATE INTO THE AFT FILLER PIECE, LEAVING THE NAIL HEADS PROTRUDING THRU THE SLOTS TO PROVIDE LATERAL AND VERTICAL RESTRAINT.
17. NAIL THE TWO REMAINING 12d RETAINING NAILS THRU THE SLOTS IN THE FORWARD CROP END GATE INTO THE FORWARD BLOCKING ASSEMBLY, LEAVING THE NAIL HEADS PROTRUDING THRU THE SLOTS TO PROVIDE LATERAL RESTRAINT.

BILL OF MATERIAL

LUMBER	LINEAR FEET	BOARD FEET
1" X 4"	8	3
2" X 4"	69	46
1" X 8"	8	6
2" X 8"	18	24
NAILS	NO. REQD	POUNDS
6d (2")	110	3/4
10d (3")	56	1
12d (3-1/4")	4	NIL
2" WEB STRAP TIEDOWN ASSEMBLY - 1 REQD - - - - 6 LBS		
HARDBOARD, 1/8" THICK - - - - 33 SQ FT - - - 13 LBS		
2" STEEL EDGE PROTECTOR - - - - 8 REQD - - - 1/2 LBS		

GENERAL NOTES

- A. THIS APPENDIX CANNOT STAND ALONE BUT MUST BE USED IN CONJUNCTION WITH THE BASIC LOADING PROCEDURES DRAWING 19-48-4905-CA17Q8. TO PRODUCE AN APPROVED LOAD, ALL PERTINENT PROCEDURES, SPECIFICATIONS AND CRITERIA SET FORTH WITHIN THE BASIC DRAWING WILL APPLY TO THE PROCEDURES DELINEATED IN THIS APPENDIX. ANY EXCEPTIONS TO THE BASIC PROCEDURES ARE SPECIFIED IN THIS APPENDIX.
- B. THE OUTLOADING PROCEDURES DEPICTED IN THIS DRAWING ARE APPLICABLE TO LOADS OF SCL #2. SEE PAGES 4 THRU 6 FOR DETAILS OF THE PALLET UNITS. AN M3 (SUMMA) CROP IS SHOWN AS TYPICAL. OTHER MANUFACTURER'S CROPS CAN BE USED FOR THE LOAD SHOWN ON PAGE 2. THE SEQUENTIAL LOADING PROCEDURES DEPICTED AT LEFT DESCRIBE THE SEQUENCE USED TO LOAD AN M3 CROP. FOR AN M3A1 (HYUNDAI) CROP, SEQUENTIAL LOADING PROCEDURES 2 THROUGH 4 MUST BE REVERSED. ACTUAL CROP CONFIGURATION WILL DETERMINE WHETHER THE SEQUENTIAL LOADING STARTS AT THE AFT OR THE FORWARD END OF THE CROP.
- C. THE LOADING PROCEDURES DEPICTED HEREIN MAY ALSO BE USED FOR OUTLOADING SIMILAR SCL LOADS WHEN IDENTIFIED BY DIFFERENT NATIONAL STOCK NUMBERS (NSN) THAN WHAT IS SHOWN ON PAGE 4, PROVIDED THE OVERALL PALLET UNIT DIMENSIONS DO NOT VARY FROM WHAT IS DELINEATED HEREIN.
- D. LIGHT PALLET UNITS MUST BE CONSTRUCTED IN ACCORDANCE WITH THE GUIDELINES DELINEATED IN THE BASIC UNITIZATION PROCEDURES DRAWING APPLICABLE TO THAT PALLET UNIT.
- E. DIMENSIONS, CUBE AND WEIGHT OF THE PALLET UNITS WILL VARY SLIGHTLY DEPENDING UPON THE ACTUAL DIMENSIONS OF THE BOXES AND THE WEIGHT OF THE SPECIFIC ITEM BEING UNITIZED.
- F. ALTERNATE NSN/DODIC COMBINATIONS ARE SHOWN IN THE CHART ON PAGE 4. THESE ALTERNATES MAY BE SUBSTITUTED FOR SOME OR ALL THE DEPICTED NSN/DODICS IF NECESSARY DUE TO THE ITEMS OR QUANTITIES ON HAND.
- G. DIMENSIONS GIVEN FOR DUNNAGE ASSEMBLIES WILL BE FIELD CHECKED PRIOR TO THEIR ASSEMBLY. PALLET UNITS MUST FIT SNUGLY AGAINST THE DUNNAGE ASSEMBLIES. THIS GUIDANCE MUST BE APPLIED PRIOR TO BEGINNING AN OUTLOADING OPERATION. ALSO, DUE TO VARIATION OF PALLET UNIT DIMENSIONS, ADJUSTMENTS MAY BE REQUIRED AS TO THE LOCATION OF CERTAIN PIECES ON DUNNAGE ASSEMBLIES.
- H. ALL WEB STRAP TIEDOWN ASSEMBLIES MUST HAVE THE EXCESS LENGTH OF THE STRAP SECURED. ROLL UP AND BUNDLE THE EXCESS LENGTH OF WEB STRAP, SECURING WITH CABLE TIES. SEE THE "STRAP END SECUREMENT" DETAIL AND GENERAL NOTE "K.12" IN THE BASIC PROCEDURE DRAWING 19-48-4905-CA17Q8.
- J. CONVERSION TO METRIC EQUIVALENTS: DIMENSIONS WITHIN THIS DOCUMENT ARE EXPRESSED IN INCHES, AND WEIGHTS ARE EXPRESSED IN POUNDS. WHEN NECESSARY, THE METRIC EQUIVALENTS MAY BE COMPUTED ON THE BASIS OF ONE INCH EQUALS 25.4MM AND ONE POUND EQUALS 0.454 KG.

LOAD AS SHOWN

ITEM	QUANTITY	WEIGHT (APPROX)
A131 PALLET UNIT	2	2,608 LBS
A576 PALLET UNIT	2	1,982 LBS
C791 PALLET UNIT	2	4,960 LBS
C792 PALLET UNIT	8	18,112 LBS
G815/G826 PLT UNIT	1	779 LBS
DUNNAGE		180 LBS
CROP		3,800 LBS
TOTAL WEIGHT		32,421 LBS (APPROX)

SCL #2 COMPOSITION CHART

DODIC	NSN	NOMENCLATURE	UNIT DWG	REQD	UNITS REQD	HC
A131	1305-00-892-2150	CTG, 7.62MM 4 BALL M80/1 TR M62 LINKED	4116/7	25,600	2 LT PLTS	1.4S
A576 ●	1305-00-028-6603	CTG, CAL .50 4 API M8/1 API-T M20 LINKED	4116/14	4,800	2 LT PLTS	1.4G
C791 ▲	1315-01-333-0534	CTG, 120MM HEAT-MP-T M830E1	4231/48	60	2 PALLETS	1.2E
C792 ●	1315-01-361-5023	CTG, 120MM APFSDS-T M829A2	4231/48	240	8 PALLETS	1.2C
G815	1330-01-124-5031	GREND, LNCHR SMK: SCREENING RP UK L8A3	4116/66E	48	12 BOXES	1.4G
G826	1330-01-171-8869	GREND, LNCHR SMK: IR SCREENING M76	4169/56	48	12 BOXES	1.2G

NOTE: THE DODICS LISTED BELOW MAY BE USED AS ALTERNATES FOR THE DODICS WITH MATCHING SYMBOLS SHOWN ABOVE IF THE QUANTITY OF THE DODICS SHOWN ABOVE IS INSUFFICIENT.

A540 ●	1305-00-935-2017	CTG, CAL .50 4 API M8/1 TR M17 LINKED	4116/14			1.4G
C787 ▲	1315-01-232-4638	CTG, 120MM HEAT-MP-T M830	4231/48			1.2E
C380 ●	1315-01-286-2256	CTG, 120MM APFSDS-T M829A1	4231/48			1.2C

THE G815/G826 LIGHT PALLET UNIT CONSISTS OF 24 M2 CANS OF G815/G826 INSERTED INTO THE BOX RESTRAINT PALLET UNIT. SEE DETAIL OF THE BOX RESTRAINT PALLET UNIT ON PAGE 9. FILL BOX RESTRAINTS WITH M2 CANS BEFORE LOAD STRAPS AND TIEDOWN STRAPS ARE TENSIONED AND SEALED.

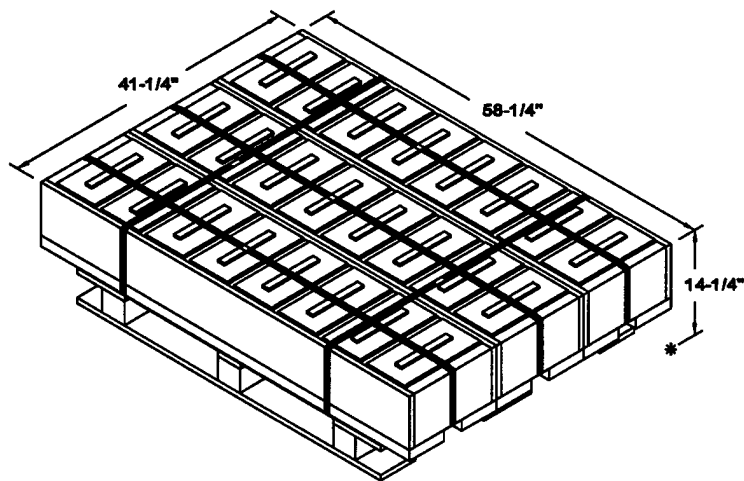

LIGHT G815/G826 PALLET UNIT DETAIL

12 BOXES OF G815 SMOKE GRENADE (4 PER BOX) @ 23 LBS -	276 LBS (APPROX)
12 BOXES OF G826 SMOKE GRENADE (4 PER BOX) @ 23 LBS -	276 LBS (APPROX)
DUNNAGE - - - - -	154 LBS
PALLET - - - - -	80 LBS
<hr/>	
TOTAL WEIGHT - - - - -	786 LBS (APPROX)
CUBE - - - - -	19.8 CU FT (APPROX)

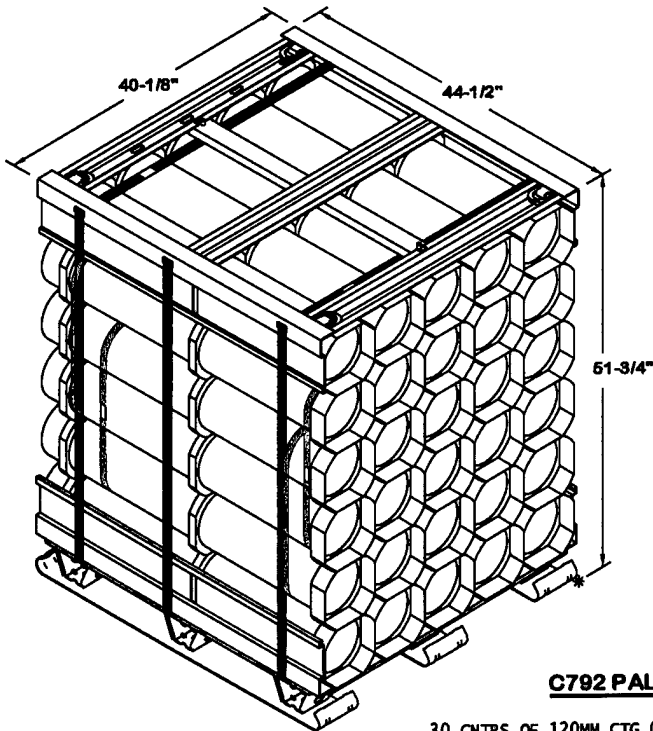

C792 PALLET UNIT DETAIL

30 CNTRS OF 120MM CTG (1 PER CNTR) AT 69 LBS	-----	2,070 LBS (APPROX)
DUNNAGE	-----	89 LBS
PALLET	-----	105 LBS
<hr/>		
TOTAL WEIGHT	-----	2,264 LBS (APPROX)
CUBE	-----	53.5 CU FT (APPROX)

C791 PALLET UNIT DETAIL

30 CNTRS OF 120MM CTG (1 PER CNTR) AT 76 LBS	-----	2,280 LBS (APPROX)
DUNNAGE	-----	100 LBS
PALLET	-----	100 LBS
<hr/>		
TOTAL WEIGHT	-----	2,480 LBS (APPROX)
CUBE	-----	53.5 CU FT (APPROX)

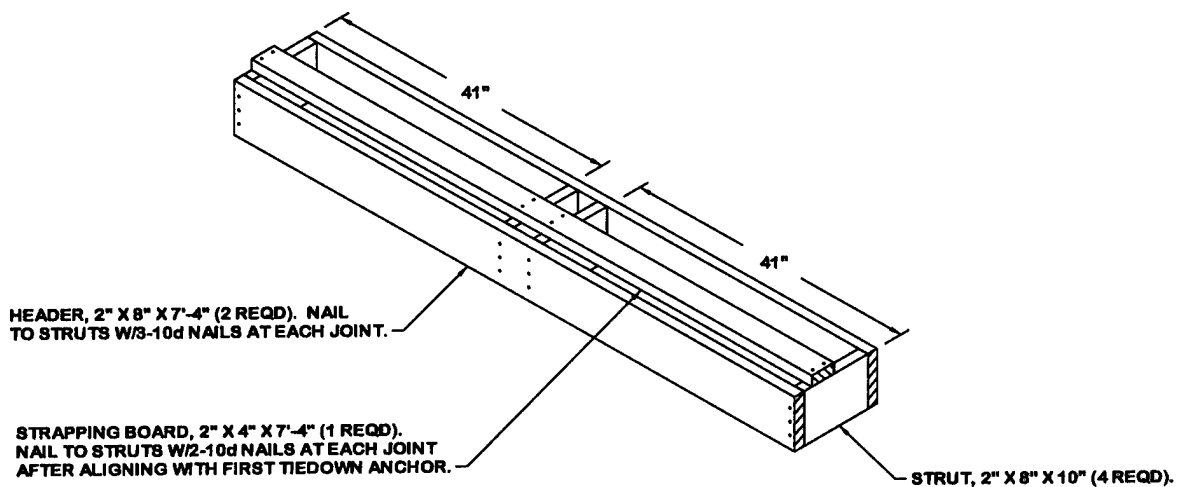

FORWARD BLOCKING ASSEMBLY

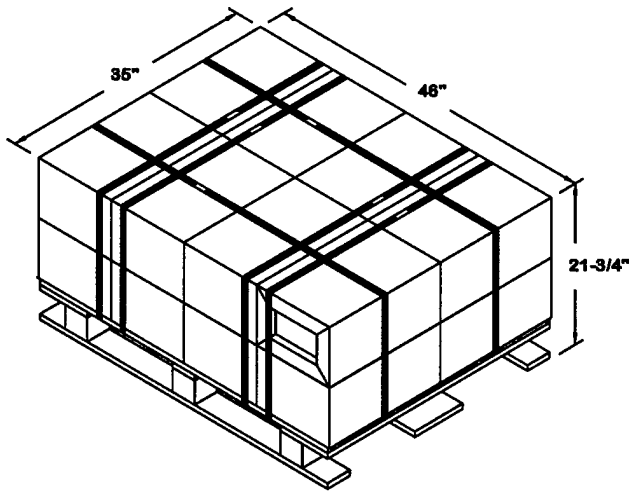

THE A131 LIGHT PALLET UNIT SHOULD BE CONSTRUCTED IAW THE AMC DRAWING LISTED ON PAGE 4 WITH THE FOLLOWING CHANGES:

1. ELIMINATE THREE LAYERS OF BOXES (24 BOXES).
2. ELIMINATE THREE HORIZONTAL STRAPS, IF USED, OR REDUCE LOAD STRAP LENGTH TO 11'-8".
3. REDUCE THE TIEDOWN STRAP LENGTH TO 9'-8".

LIGHT A131 PALLET UNIT DETAIL

16 BOXES OF 7.62MM CTG (800 PER BOX) AT 77 LBS	---	1232 LBS (APPROX)
DUNNAGE	-----	7 LBS
PALLET	-----	65 LBS
<hr/>		
TOTAL WEIGHT	-----	1304 LBS (APPROX)
CUBE	-----	20.2 CU FT (APPROX)

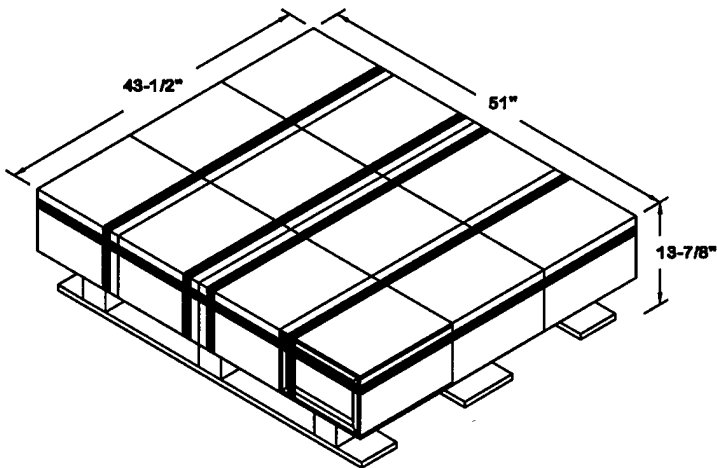

THE A576 LIGHT PALLET UNIT SHOULD BE CONSTRUCTED IAW THE AMC DRAWING LISTED ON PAGE 4 WITH THE FOLLOWING CHANGES:

1. ELIMINATE THREE LAYERS OF BOXES (36 BOXES).
2. ELIMINATE THREE HORIZONTAL STRAPS.
3. REDUCE THE TIEDOWN STRAP LENGTH TO 9'-5".

LIGHT A576 PALLET UNIT DETAIL

12 BOXES OF .50 CAL CTG (200 PER BOX) AT 75 LBS	---	900 LBS (APPROX)
DUNNAGE	-----	11 LBS
PALLET	-----	80 LBS
<hr/>		
TOTAL WEIGHT	-----	991 LBS (APPROX)
CUBE	-----	17.8 CU FT (APPROX)

BEARING PIECE, 2" X 4" X 65" (1 REQD).

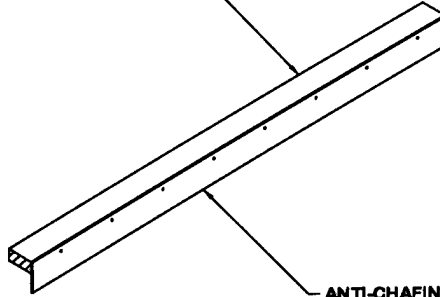

ANTI-CHAFING PIECE, HARDBOARD
1/8" X 4" X 65" (1 REQD). LAMINATE
TO BEARING PIECE W/8d NAILS.

AFT END STRAPPING BOARD ASSEMBLY

BEARING PIECE, 2" X 4" X 7'-4" (1 REQD).

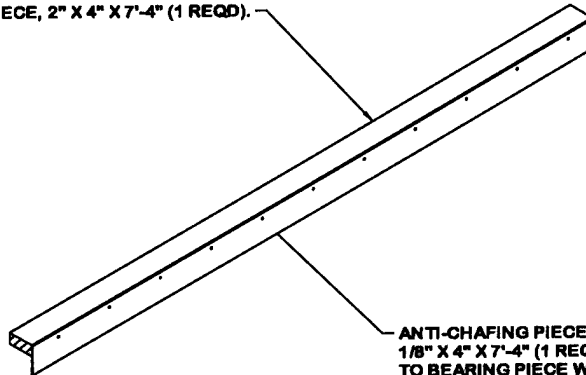

ANTI-CHAFING PIECE, HARDBOARD,
1/8" X 4" X 7'-4" (1 REQD). LAMINATE
TO BEARING PIECE W/11-8d NAILS.

FORWARD END STRAPPING BOARD ASSEMBLY

NOTE: PRODUCE EQUAL QUANTITIES OF ASSEMBLY A AND ASSEMBLY B. EACH CROP LOAD REQUIRES TWO OF EACH (4 TOTAL).

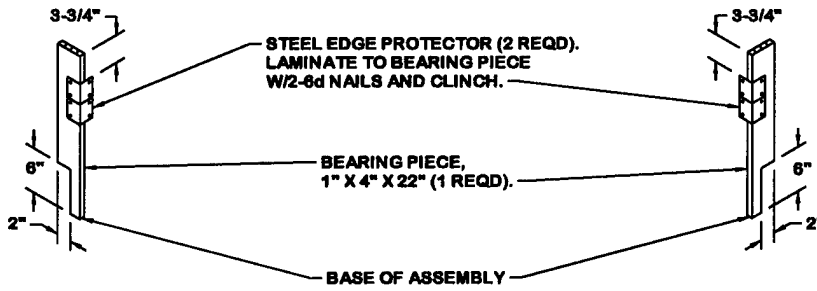

CORNER STRAPPING BOARD ASSEMBLY A

CORNER STRAPPING BOARD ASSEMBLY B

BEARING PIECE, 2" X 4" X 48" (2 REQD). LAMINATE FIRST PIECE TO SECOND PIECE W/4-10d NAILS.

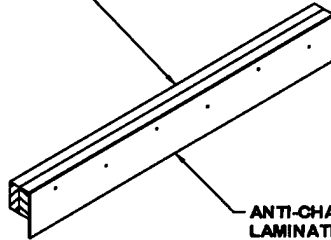

ANTI-CHAFING PIECE, HARDBOARD, 1/8" X 6" X 48" (1 REQD). LAMINATE TO BEARING PIECE W/8-8d NAILS.

SIDE STRAPPING BOARD ASSEMBLY

NOTE: FOR ALL DUNNAGE USING 1/8" HARDBOARD MATERIAL, LUAN UNDERLAYMENT (3/16" THICK) MAY BE SUBSTITUTED IF SUFFICIENT HARDBOARD MATERIAL IS UNAVAILABLE.

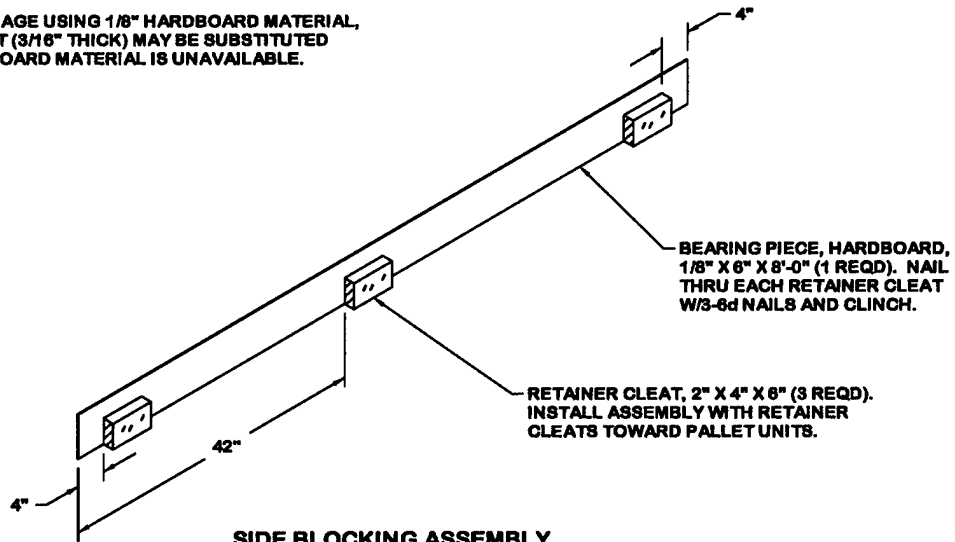

SIDE BLOCKING ASSEMBLY

LOAD STRAP, 3/4" X .035" OR .031" X 12'-5" LONG STEEL STRAPPING (3 REQD). PRE-POSITION ON THE PALLET DECK PRIOR TO PLACING BOX RESTRAINTS. LOAD STRAPS MUST BE TENSIONED AND SEALED PRIOR TO APPLICATION OF TIEDOWN STRAPS.

BOX RESTRAINT (3 REQD). SEE THE DETAIL BELOW.

SEAL FOR 3/4" STRAPPING (5 REQD). CRIMP EACH SEAL WITH TWO PAIR OF NOTCHES.

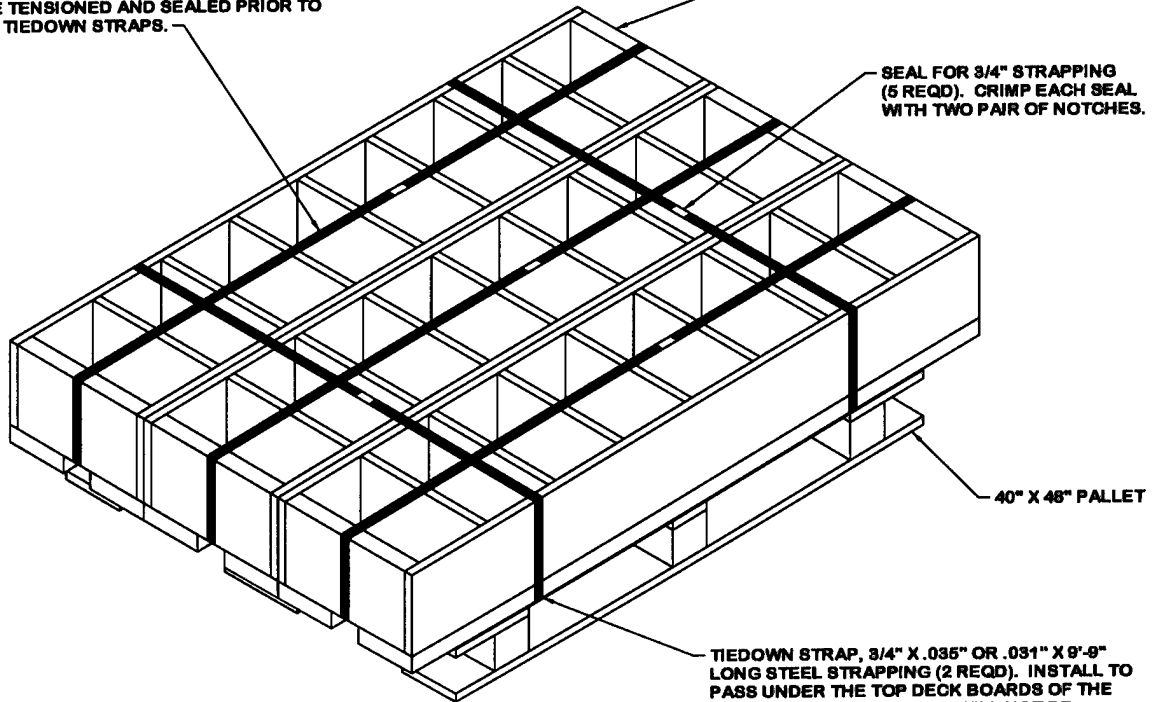

BOX RESTRAINT PALLET UNIT
SEE BILL OF MATERIAL ON PAGE 10.

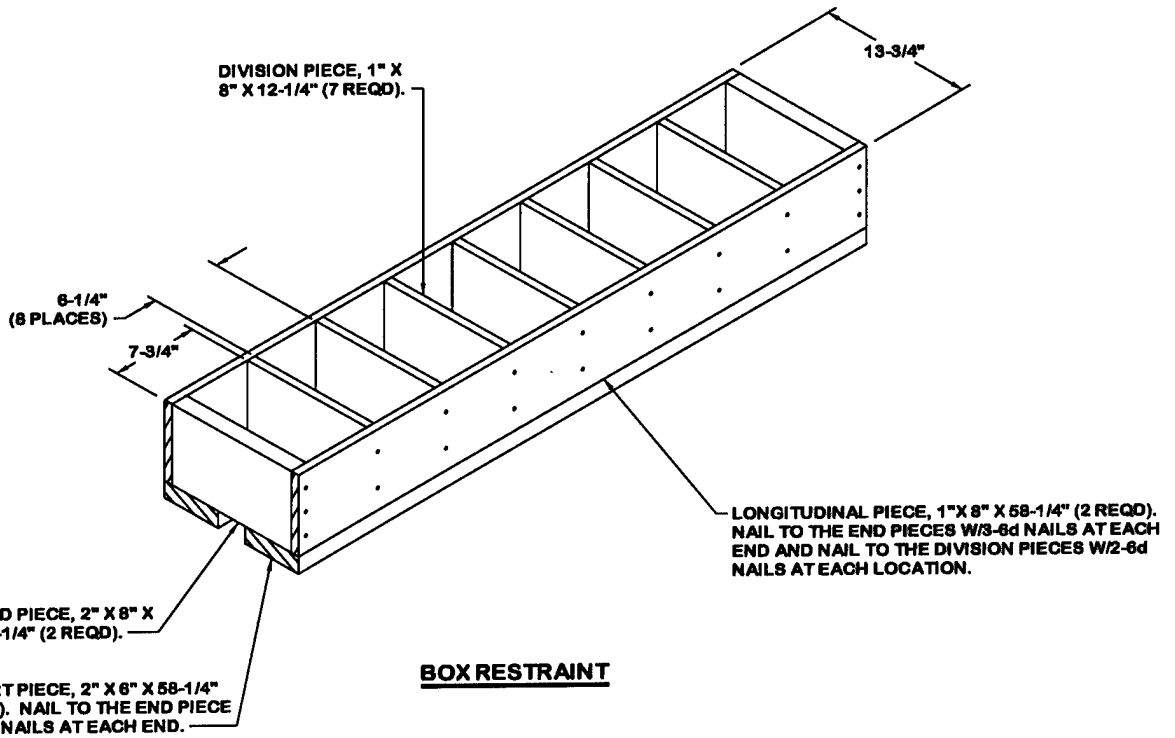

BILL OF MATERIAL (BOX RESTRAINT PALLET UNIT)		
LUMBER	LINEAR FEET	BOARD FEET
2" X 6"	30	30
1" X 8"	51	34
2" X 8"	7	10
NAILS	NO. REQD	POUNDS
6d (2")	120	3/4
10d (3")	24	1/2
3/4" STEEL STRAPPING - - - - - 57 FT - - - - 4 LBS		
SEAL FOR 3/4" STRAPPING - - - - 5 REQD - - - - NIL		
40" X 48" PALLET - - - - - 1 REQD - - - - 80 LBS		

APPROVED BY
BUREAU OF EXPLOSIVES

D. H.

DATE 9/29/00

APPENDIX 23

LOADING AND BRACING PROCEDURES FOR STRATEGIC CONFIGURED LOAD (SCL) ON CONTAINER ROLL IN/OUT PLATFORM (CROP)

SCL #23 - 155MM DPICM M483A1

INDEX

<u>ITEM</u>	<u>PAGE(S)</u>
TYPICAL LOADING PROCEDURES	2
GENERAL NOTES AND SEQUENTIAL LOADING PROCEDURES	3
PALLET UNIT DETAILS	4-6
DETAILS	7-9

NOTICE: THIS APPENDIX CANNOT STAND ALONE BUT MUST BE USED IN CONJUNCTION WITH THE BASIC CROP OUTLOADING PROCEDURES DRAWING 19-48-4905-CA17Q6.

- LOADING AND BRACING SPECIFICATIONS SET FORTH WITHIN THIS DRAWING ARE APPLICABLE TO LOADS THAT ARE TO BE SHIPPED BY TRAILER/CONTAINER-ON-FLATCAR (T/COFC) RAIL CARRIER SERVICE. THESE SPECIFICATIONS MAY ALSO BE USED FOR LOADS THAT ARE TO BE MOVED BY MOTOR OR WATER CARRIERS.

U.S. ARMY MATERIEL COMMAND DRAWING

APPROVED, U.S. ARMY OPERATIONS SUPPORT COMMAND <i>Amaly R. Fore</i> APPROVED BY ORDER OF COMMANDING GENERAL, U.S. ARMY MATERIEL COMMAND <i>[Signature]</i> U.S. ARMY DEFENSE AMMUNITION CENTER	ENGINEER	BASIC	LAURA FIEFFER	DO NOT SCALE			
		REV.		WEBSITE: HTTP://WWW.DAC.ARMY.MIL			
	TECHNICIAN	BASIC		SEPTEMBER 2000			
	REV.						
DRAFTSMAN	BASIC						
	REV.						
	TRANSPORTATION ENGINEERING DIVISION		<i>William P. Merich</i>	CLASS	DIVISION	DRAWING	FILE
	VALIDATION ENGINEERING DIVISION		<i>[Signature]</i>	19	48	4905/ 23	CA17Q6
	ENGINEERING DIRECTORATE		<i>Johnnie L. Beck</i>				

PROJECT CAP-TV 8/23-00

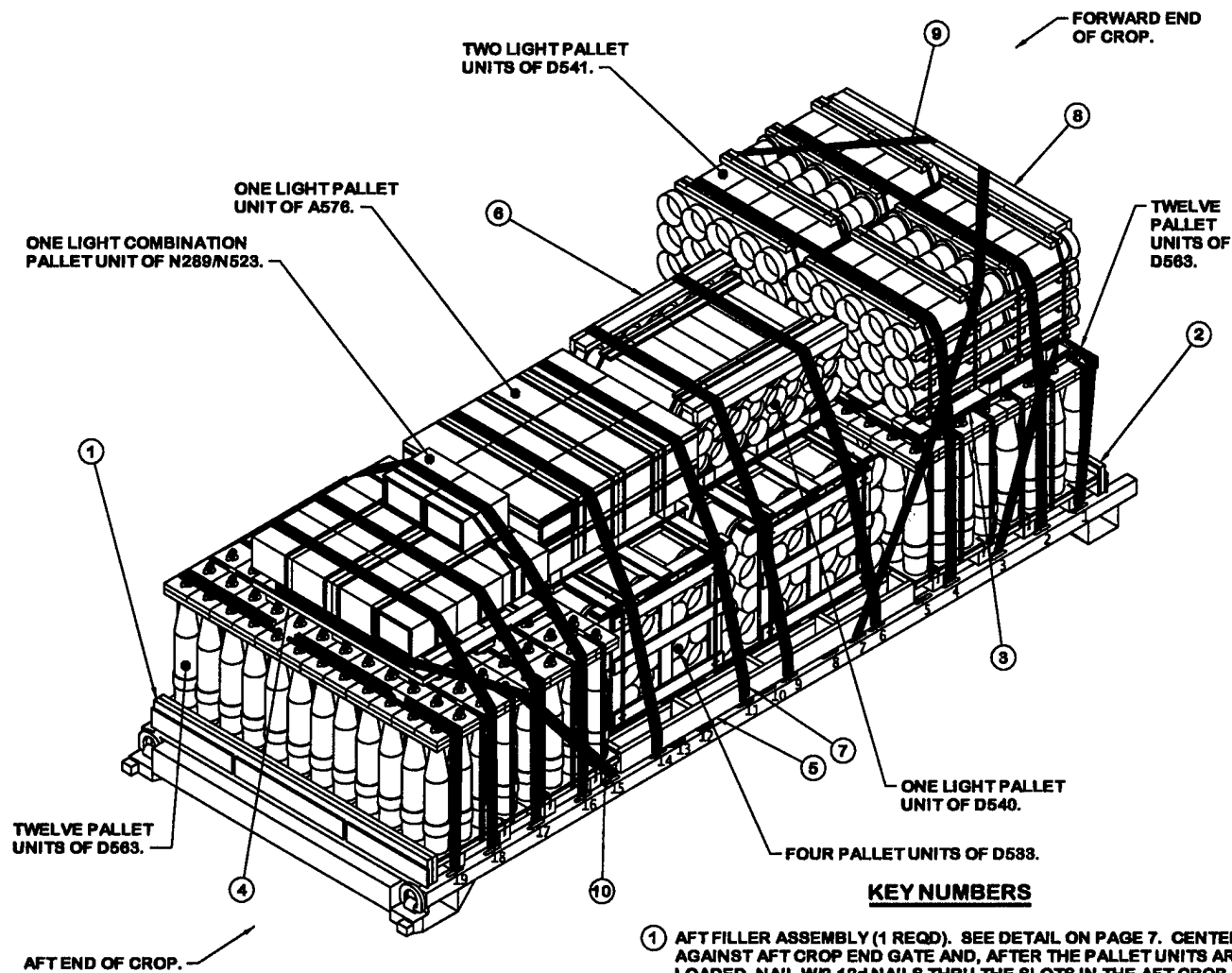

ISOMETRIC VIEW

(KEY NUMBERS CONTINUED)

KEY NUMBERS

- ① AFT FILLER ASSEMBLY (1 REQD). SEE DETAIL ON PAGE 7. CENTER AGAINST AFT CROP END GATE AND, AFTER THE PALLET UNITS ARE LOADED, NAIL W/2-12d NAILS THRU THE SLOTS IN THE AFT CROP END GATE INTO THE AFT FILLER ASSEMBLY, LEAVING THE NAIL HEADS PROTRUDING THRU THE SLOTS TO PROVIDE LATERAL RESTRAINT.
- ② FORWARD FILLER, 1" OR 2" X 8" X 7'-4" (AS REQD). LAMINATE EACH PIECE TO THE PREVIOUS PIECE W/8 NAILS OF A SUITABLE SIZE (6d NAILS FOR 1" THICK MATERIAL). CENTER AGAINST FORWARD CROP END GATE AND, AFTER THE PALLET UNITS ARE LOADED, NAIL W/2-12d NAILS THRU THE HOLES IN THE FORWARD CROP END GATE INTO THE FORWARD FILLER PIECES, LEAVING THE NAIL HEADS PROTRUDING THRU THE HOLES TO PROVIDE LATERAL AND VERTICAL RESTRAINT.
- ③ PALLET SUPPORT ASSEMBLY A (1 REQD). SEE DETAIL ON PAGE 7. POSITION THE ASSEMBLY ON TOP OF THE FORWARD D563 PALLET UNITS SO THAT ASSEMBLY LATERAL PIECES ARE CROSSWISE ON THE LOAD AND FIT BETWEEN THE LIFTING RINGS OF THE D563 PROJECTILES. CENTER THE ASSEMBLY Laterally AND LONGITUDINALLY ON THE D563 PALLET.
- ④ PALLET SUPPORT ASSEMBLY B (1 REQD). SEE DETAIL ON PAGE 8. POSITION THE ASSEMBLY ON TOP OF THE AFT D563 PALLET UNITS SO THAT ASSEMBLY LATERAL PIECES ARE LENGTHWISE ON THE LOAD AND FIT BETWEEN THE LIFTING RINGS OF THE D563 PROJECTILES. CENTER THE ASSEMBLY Laterally ON THE D563 PALLET UNITS AND POSITION SO THAT THE LIGHT COMBINATION N289/N523 PALLET UNIT WILL BE TIGHT AGAINST THE ADJACENT LIGHT A576 PALLET UNIT.
- ⑤ SIDE BLOCKING ASSEMBLY (2 REQD). SEE THE DETAIL ON PAGE 8. INSTALL ONE ON EACH SIDE OF THE CROP ADJACENT TO THE D583 PALLET UNITS. AFTER THE HOLD-DOWN STRAPS ARE INSTALLED, NAIL THROUGH THE STRAP ATTACHMENT SLOTS OF TWO HOLD-DOWN STRAPS (ONE AT EACH END OF THE ASSEMBLY) INTO SIDE BLOCKING W/1-10d PARTIALLY DRIVEN NAIL AND BEND OVER SIDE OF HOOK.
- ⑥ STRAPPING BOARD ASSEMBLY A (2 REQD). SEE THE DETAIL ON PAGE 9. INSTALL ON THE EDGES OF THE D640 PALLET UNIT.
- ⑦ HOLD-DOWN STRAP, 3-INCH WIDE WEB STRAP TIEDOWN ASSEMBLY FOR CROP (11 REQD). INSTALL EACH HOLD-DOWN STRAP TO EXTEND FROM THE DESIGNATED TIEDOWN ANCHOR ON ONE SIDE OF CROP, OVER THE TOP OF THE PALLET UNITS, TO THE CORRESPONDING TIEDOWN ANCHOR ON THE OPPOSITE SIDE OF THE CROP. ALIGN SCUFF SLEEVES OVER ALL SHARP EDGES AND FIRMLY TENSION STRAP. SEE GENERAL NOTE "H" ON PAGE 3.
- ⑧ STRAPPING BOARD ASSEMBLY B (1 REQD). SEE THE DETAIL ON PAGE 9. INSTALL ON THE FORWARD EDGE OF THE D541 PALLET UNITS.
- ⑨ FORWARD END RESTRAINT STRAP, 3-INCH WIDE WEB STRAP TIEDOWN ASSEMBLY FOR CROP (2 REQD). INSTALL EACH STRAP FROM THE THIRD TIEDOWN ANCHOR ON ONE SIDE OF THE CROP (ONE ON EACH SIDE), OVER THE D563 AND LIGHT D541 PALLET UNITS AND STRAPPING BOARD ASSEMBLY B, BACK DOWN TO THE SEVENTH TIEDOWN ANCHOR ON THE OPPOSITE SIDE OF THE CROP. ALIGN SCUFF SLEEVES OVER ALL SHARP EDGES AND FIRMLY TENSION STRAP. CAUTION: THE RATCHET MUST BE POSITIONED TO AVOID CONTACT WITH THE CONTAINER WHEN INSERTING CROP INTO CONTAINER. SEE GENERAL NOTE "H" ON PAGE 3.
- ⑩ AFT END RESTRAINT STRAP, 3-INCH WIDE WEB STRAP TIEDOWN ASSEMBLY FOR CROP (1 REQD). INSTALL THE STRAP FROM THE FIFTEENTH TIEDOWN ANCHOR ON ONE SIDE OF THE CROP, AT AN ANGLE OVER THE D583 PALLET UNITS, AROUND THE PALLET POSTS OF THE LIGHT COMBINATION N289/N523 PALLET UNIT, AND BACK DOWN TO THE FIFTEENTH TIEDOWN ANCHOR ON THE OPPOSITE SIDE OF THE CROP. DO NOT INSTALL OVER THE HOLD-DOWN STRAP ATTACHED TO THE EIGHTEENTH TIEDOWN ANCHOR, THREAD BEHIND THIS STRAP, FLUSH AGAINST THE D583 PALLET UNIT. ALIGN SCUFF SLEEVES OVER ALL SHARP EDGES AND FIRMLY TENSION STRAP. SEE GENERAL NOTE "H" ON PAGE 3.

(CONTINUED AT LEFT)

RECOMMENDED SEQUENTIAL PROCEDURES

1. PREFABRICATE THE AFT FILLER ASSEMBLY, THREE PALLET SUPPORT ASSEMBLIES, TWO STRAPPING BOARD "A" ASSEMBLIES, THE STRAPPING BOARD "B" ASSEMBLY, AND TWO SIDE BLOCKING ASSEMBLIES. STRAP THE N523 BOX AND THE EXTRA N289 BOX TO THE TOP OF THE LIGHT N289 PALLET UNIT.
2. INSTALL THE AFT FILLER ASSEMBLY.
3. LOAD TWO ROWS OF SIX PALLET UNITS OF D563 AGAINST THE AFT END FILLER ASSEMBLY, CENTERING Laterally ON THE CROP.
4. LOAD TWO ROWS OF TWO PALLET UNITS OF D533 AGAINST THE D563 PALLET UNITS, CENTERING Laterally ON THE CROP.
5. LOAD TWO ROWS OF SIX PALLET UNITS OF D563 AGAINST THE D533 PALLET UNITS, CENTERING THE ROWS Laterally ON THE CROP.
6. INSTALL THE FORWARD FILLER PIECES.
7. INSTALL THE PALLET SUPPORT ASSEMBLY "A" ON TOP OF THE FORWARD D563 PALLET UNITS SO THAT THE LATERAL PIECES OF THE ASSEMBLY FIT BETWEEN THE LIFTING EYES ON THE D563 PALLET UNITS AND ARE CROSSWISE ON THE LOAD, AND THE ASSEMBLY IS CENTERED AS MUCH AS POSSIBLE Laterally AND Longitudinally ON THE D563 PALLET UNITS.
8. LOAD TWO LIGHT D541 PALLET UNITS ON TOP OF THE PALLET SUPPORT ASSEMBLY "A", ALIGNING THE PALLET SKIDS WITH THE PALLET SUPPORT ASSEMBLY LONGITUDINAL PIECES.
9. LOAD ONE LIGHT D540 PALLET UNIT, CENTERED Laterally, ON TOP OF THE FORWARD D533 PALLET UNITS, AND AGAINST THE D541 PALLET UNITS.
10. LOAD ONE LIGHT A576 PALLET UNIT, CENTERED Laterally, ON TOP OF THE AFT D533 PALLET UNITS, AND AGAINST THE D540 PALLET UNIT. SEE GENERAL NOTE "F" AT RIGHT.
11. INSTALL THE PALLET SUPPORT ASSEMBLY "B" ON TOP OF THE AFT D563 PALLET UNITS SO THAT THE LATERAL PIECES OF THE ASSEMBLY FIT BETWEEN THE LIFTING EYES ON THE D563 PALLET UNITS AND ARE LENGTHWISE ON THE LOAD, AND ARE CENTERED AS MUCH AS POSSIBLE Laterally ON THE D563 PALLET UNITS.
12. LOAD ONE LIGHT N289/N523 COMBINATION PALLET UNIT ON TOP OF THE PALLET SUPPORT ASSEMBLY "B", ALIGNING THE PALLET SKIDS WITH THE PALLET SUPPORT ASSEMBLY LONGITUDINAL PIECES. SEE GENERAL NOTE "F" AT RIGHT.
13. INSTALL THE TWO SIDE BLOCKING ASSEMBLIES.
14. INSTALL THE STRAPPING BOARD ASSEMBLIES "A".
15. INSTALL 11 WEB STRAP TIEDOWN ASSEMBLIES TO EXTEND FROM A TIEDOWN ANCHOR ON ONE SIDE OF THE CROP, OVER THE TOP OF PALLET UNITS, TO THE CORRESPONDING TIEDOWN ANCHOR ON THE OPPOSITE SIDE OF THE CROP.

(CONTINUED ON PAGE 4)

GENERAL NOTES

- A. THIS APPENDIX CANNOT STAND ALONE BUT MUST BE USED IN CONJUNCTION WITH THE BASIC LOADING PROCEDURES DRAWING 19-48-4905-CA17Q6. TO PRODUCE AN APPROVED LOAD, ALL PERTINENT PROCEDURES, SPECIFICATIONS AND CRITERIA SET FORTH WITHIN THE BASIC DRAWING WILL APPLY TO THE PROCEDURES DELINEATED IN THIS APPENDIX. ANY EXCEPTIONS TO THE BASIC PROCEDURES ARE SPECIFIED IN THIS APPENDIX.
- B. THE OUTLOADING PROCEDURES DEPICTED IN THIS DRAWING ARE APPLICABLE TO LOADS OF SCL #23. SEE PAGES 4 THRU 6 FOR DETAILS OF THE PALLET UNITS. AN M3A1 (HYUNDAI) CROP IS SHOWN AS TYPICAL. OTHER MANUFACTURER'S CROPS CAN BE USED FOR THE LOAD SHOWN ON PAGE 2. THE SEQUENTIAL LOADING PROCEDURES DEPICTED AT LEFT DESCRIBE THE SEQUENCE USED TO LOAD AN M3A1 CROP. FOR AN M3 (SUMMA) CROP, SEQUENTIAL LOADING PROCEDURES 2 THROUGH 6 MUST BE REVERSED. ACTUAL CROP CONFIGURATION WILL DETERMINE WHETHER THE SEQUENTIAL LOADING STARTS AT THE AFT OR THE FORWARD END OF THE CROP.
- C. THE LOADING PROCEDURES DEPICTED HEREIN MAY ALSO BE USED FOR OUTLOADING SIMILAR SCL LOADS WHEN IDENTIFIED BY DIFFERENT NATIONAL STOCK NUMBERS (NSN) THAN WHAT IS SHOWN ON PAGE 4, PROVIDED THE OVERALL PALLET UNIT DIMENSIONS DO NOT VARY FROM WHAT IS DELINEATED HEREIN.
- D. LIGHT PALLET UNITS MUST BE CONSTRUCTED IN ACCORDANCE WITH THE GUIDELINES DELINEATED IN THE BASIC UNITIZATION PROCEDURES DRAWING APPLICABLE TO THAT PALLET UNIT.
- E. DIMENSIONS, CUBE AND WEIGHT OF THE PALLET UNITS WILL VARY SLIGHTLY DEPENDING UPON THE ACTUAL DIMENSIONS OF THE BOXES AND THE WEIGHT OF THE SPECIFIC ITEM BEING UNITIZED.
- F. ALTERNATE NSN/DODIC COMBINATIONS ARE SHOWN IN THE CHART ON PAGE 4. THESE ALTERNATES MAY BE SUBSTITUTED FOR SOME OR ALL THE DEPICTED NSN/DODICS IF NECESSARY DUE TO THE ITEMS OR QUANTITIES ON HAND.
- G. DIMENSIONS GIVEN FOR DUNNAGE ASSEMBLIES WILL BE FIELD CHECKED PRIOR TO THEIR ASSEMBLY. PALLET UNITS MUST FIT SNUGLY AGAINST THE DUNNAGE ASSEMBLIES. THIS GUIDANCE MUST BE APPLIED PRIOR TO BEGINNING AN OUTLOADING OPERATION. ALSO, DUE TO VARIATION OF PALLET UNIT DIMENSIONS, ADJUSTMENTS MAY BE REQUIRED AS TO THE LOCATION OF CERTAIN PIECES ON DUNNAGE ASSEMBLIES.
- H. ALL WEB STRAP TIEDOWN ASSEMBLIES MUST HAVE THE EXCESS LENGTH OF THE STRAP SECURED. ROLL UP AND BUNDLE THE EXCESS LENGTH OF WEB STRAP, SECURING WITH CABLE TIES. SEE THE "STRAP END SECUREMENT" DETAIL AND GENERAL NOTE "K.12" IN THE BASIC PROCEDURE DRAWING 19-48-4905-CA17Q6.
- J. CONVERSION TO METRIC EQUIVALENTS: DIMENSIONS WITHIN THIS DOCUMENT ARE EXPRESSED IN INCHES, AND WEIGHTS ARE EXPRESSED IN POUNDS. WHEN NECESSARY, THE METRIC EQUIVALENTS MAY BE COMPUTED ON THE BASIS OF ONE INCH EQUALS 25.4MM AND ONE POUND EQUALS 0.454 KG.

BILL OF MATERIAL		
LUMBER	LINEAR FEET	BOARD FEET
1" X 4"	7	3
1" X 6"	24	12
1" X 8"	8	5
2" X 3" (ACTUAL)	2	1
2" X 4"	82	55
2" X 6"	34	34
2" X 8"	30	40
NAILS	NO. REQD	POUNDS
6d (2")	56	1/2
10d (3")	122	2
12d (3-1/4")	8	1/4

LOAD AS SHOWN

ITEM	QUANTITY	WEIGHT (APPROX)
LIGHT A576 PALLET UNIT	1	1,886 LBS
D533 PALLET UNIT	4	4,640 LBS
LIGHT D540 PALLET UNIT	1	786 LBS
LIGHT D541 PALLET UNIT	2	2,146 LBS
D563 PALLET UNIT	24	20,976 LBS
COMBO N289/N523 PALLET UNIT	1	594 LBS
DUNNAGE		297 LBS
CROP		3,800 LBS

TOTAL WEIGHT - - - - - 35,125 LBS (APPROX)

SCL #23 COMPOSITION CHART

DODIC	NSN	NOMENCLATURE	UNIT DWG	REQD	UNITS REQD	HC
A576 *	1305-00-028-6603	CTG, CAL .50 4 API M8/1 API-T M20 LINKED	4116/14	4,800	1 LIGHT PLT	1.4G
D533	1320-01-093-6856	CHG, PROPELLING 155MM WB M119A2 W/O PRIMER	4042A/9	96	4 PALLETS	1.3C
D540	1320-00-935-1922	CHG, PROPELLING 155MM GB M3	4042A/3	48	1 LIGHT PLT	1.3C
D541	1320-00-935-1923	CHG, PROPELLING 155MM WB M4A2	4042A/2	60	2 LIGHT PLTS	1.3C
D563	1320-01-260-8720	PROJ, 155MM HE APER ICM M483A1	8837839	192	24 PALLETS	1.1D
N289 ^	1390-01-282-6038	FUZE, ELECTRONIC TIME W/O BOOSTER M762	4116/156S	208	13 BOXES	1.4S
N523	1390-00-892-4202	PRIMER, PERCUSSION M82	4116/158E	200	1 BOX	1.4S

NOTE: THE DODICS LISTED BELOW MAY BE USED AS ALTERNATES FOR THE DODICS WITH MATCHING SYMBOLS SHOWN ABOVE IF THE QUANTITY OF THE DODICS SHOWN ABOVE IS INSUFFICIENT.

A540 *	1305-00-935-2017	CTG, CAL .50 4 API M8/1 TR M17 LINKED	4116/14			1.4G
N285 ^	1390-01-247-4013	FUZE, MTSQ W/O BOOSTER M577A1	4116/156			1.4S

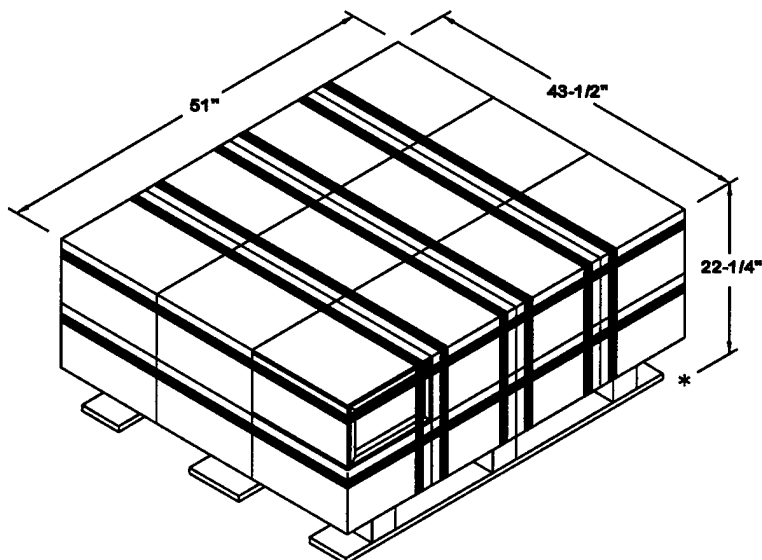

LIGHT A576 PALLET UNIT DETAIL

24 BOXES OF .50 CAL CTG (200 PER BOX) AT 75 LBS - - 1,800 LBS (APPROX)
 DUNNAGE - - - - - 6 LBS
 PALLET - - - - - 80 LBS

TOTAL WEIGHT - - - - - 1,886 LBS (APPROX)
 CUBE - - - - - 28.6 CU FT (APPROX)

THE LIGHT A576 PALLET UNIT SHOULD BE CONSTRUCTED IAW THE AMC DRAWING LISTED ABOVE WITH THE FOLLOWING CHANGES:

1. ELIMINATE TWO LAYER OF BOXES (24 BOXES).
2. ELIMINATE TWO HORIZONTAL STRAPS.
3. REDUCE THE TIEDOWN STRAP LENGTH TO 12'-5".

SEQUENTIAL PROCEDURES CONTINUED FROM PAGE 3

16. INSTALL ONE WEB STRAP TIEDOWN ASSEMBLY FROM THE THIRD TIEDOWN ANCHOR ON ONE SIDE OF THE CROP, AT AN ANGLE OVER THE D563 AND LIGHT D541 PALLET UNITS, OVER THE STRAPPING BOARD ASSEMBLY "B", BACK DOWN TO THE SEVENTH TIEDOWN ANCHOR ON THE OPPOSITE SIDE OF THE CROP. REPEAT WITH ANOTHER WEB STRAP TIEDOWN ASSEMBLY, STARTING AT THE SEVENTH ANCHOR ON THE FIRST SIDE OF THE CROP AND ENDING AT THE THIRD ANCHOR ON THE OPPOSITE SIDE OF THE CROP. CARE MUST BE TAKEN TO ENSURE THAT THE STRAPS ARE APPLIED IN SUCH A MANNER THAT THE RATCHET WILL BE OUT OF THE WAY, TO AVOID DAMAGE AND CONTACT WHEN THE CROP IS INSERTED INTO THE ISO CONTAINER.
17. INSTALL ONE WEB STRAP TIEDOWN ASSEMBLY FROM THE FIFTEENTH TIEDOWN ANCHOR ON ONE SIDE OF THE CROP, AT AN ANGLE OVER THE D563 PALLET UNITS, AROUND THE PALLET POSTS OF THE LIGHT COMBINATION N289/N523 PALLET UNIT, AND BACK DOWN TO THE FIFTEENTH TIEDOWN ANCHOR ON THE OPPOSITE SIDE OF THE CROP. DO NOT INSTALL OVER THE HOLD-DOWN STRAP ATTACHED TO THE EIGHTEENTH TIEDOWN ANCHOR, THREAD BEHIND THIS STRAP, FLUSH AGAINST THE D563 PALLET UNIT.
18. NAIL THROUGH THE HOOK SLOT OF A HOLD-DOWN STRAP INTO EACH END OF THE SIDE BLOCKING ASSEMBLIES W/1-10d PARTIALLY DRIVEN NAIL AND BEND OVER SIDE OF HOOK.
19. NAIL THROUGH THE STRAP ATTACHMENT SLOT OF THE HOLD-DOWN STRAP INTO EACH END OF THE SIDE BLOCKING ASSEMBLIES W/1-10d PARTIALLY DRIVEN NAIL AND BEND OVER SIDE OF HOOK.
20. NAIL TWO 12d RETAINING NAILS THRU THE SLOTS IN THE AFT CROP END GATE INTO THE AFT FILLER ASSEMBLY, LEAVING THE NAIL HEADS PROTRUDING THRU THE SLOTS TO PROVIDE LATERAL RESTRAINT.
21. NAIL THE TWO REMAINING 12d RETAINING NAILS THRU THE HOLES IN THE FORWARD CROP END GATE INTO THE FORWARD FILLER PIECES, LEAVING THE NAIL HEADS PROTRUDING THRU THE HOLES TO PROVIDE LATERAL AND VERTICAL RESTRAINT.

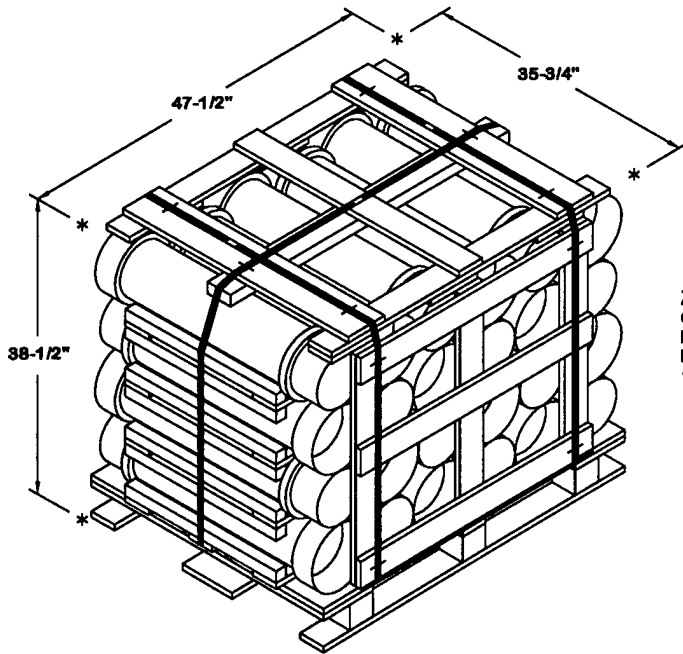

D533 PALLET UNIT DETAIL

24 CONTAINERS OF PROPELLING CHARGES (1 PER PA37 CONTAINER) AT 42 LBS	-	1,008 LBS (APPROX)
DUNNAGE	-	87 LBS
PALLET	-	65 LBS

TOTAL WEIGHT	-	1,160 LBS (APPROX)
CUBE	-	37.8 CU FT (APPROX)

THE LIGHT D540 PALLET UNIT DEPICTED AT RIGHT SHOULD BE CONSTRUCTED IAW THE AMC DRAWING LISTED IN THE CHART ON PAGE 4 WITH THE FOLLOWING CHANGES:

1. ELIMINATE TWO LAYERS OF CONTAINERS (16 CONTAINERS).
2. ELIMINATE ONE INTERMEDIATE DUNNAGE ASSEMBLY A AND ONE INTERMEDIATE DUNNAGE ASSEMBLY B.
3. REDUCE THE LOAD STRAP LENGTH TO 12'-6".

LIGHT D540 PALLET UNIT DETAIL

24 CONTAINERS OF PROPELLING CHARGES (2 PER M14 CONTAINER) AT 28 LBS	-	672 LBS (APPROX)
DUNNAGE	-	49 LBS
PALLET	-	65 LBS

TOTAL WEIGHT	-	786 LBS (APPROX)
CUBE	-	26.0 CU FT (APPROX)

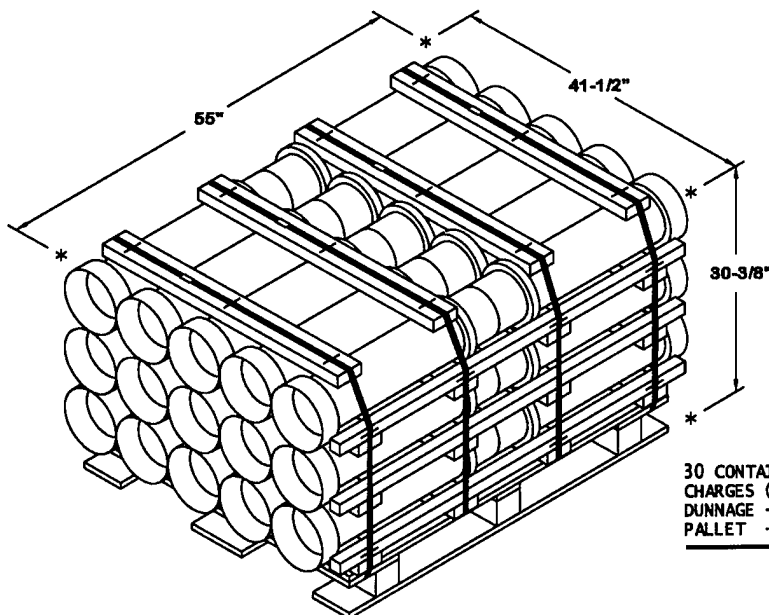
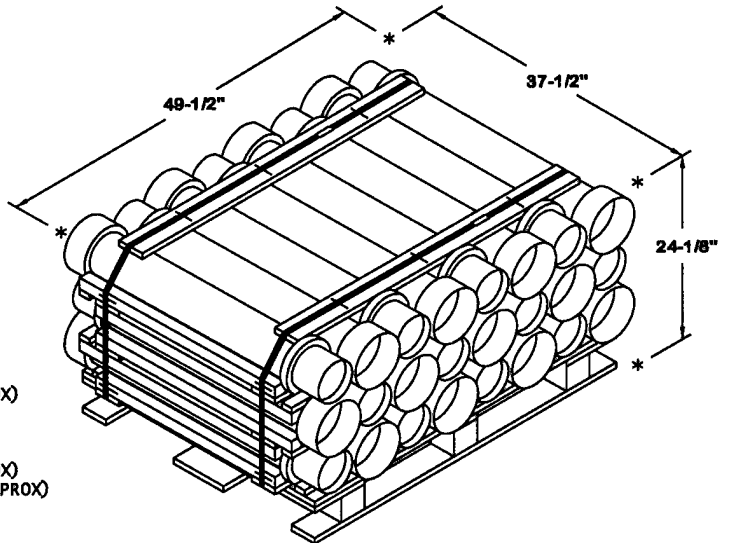

THE LIGHT D541 PALLET UNIT DEPICTED AT LEFT SHOULD BE CONSTRUCTED IAW THE AMC DRAWING LISTED IN THE CHART ON PAGE 4 WITH THE FOLLOWING CHANGES:

1. ELIMINATE TWO LAYERS OF CONTAINERS (20 CONTAINERS).
2. ELIMINATE TWO DUNNAGE ASSEMBLIES.
3. REDUCE THE TIEDOWN STRAP LENGTH TO 12'-2".

LIGHT D541 PALLET UNIT DETAIL

30 CONTAINERS OF PROPELLING CHARGES (1 PER M13 CONTAINER) AT 30 LBS	-	900 LBS (APPROX)
DUNNAGE	-	93 LBS
PALLET	-	80 LBS

TOTAL WEIGHT	-	1,073 LBS (APPROX)
CUBE	-	40.2 CU FT (APPROX)

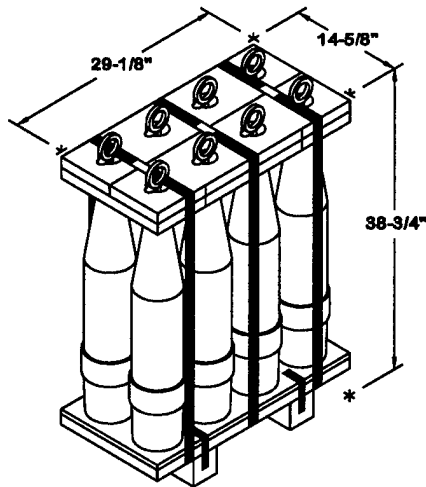

D563 PALLET UNIT DETAIL

8 155MM CTG AT 103 LBS	-----	824 LBS (APPROX)
DUNNAGE AND PALLET	-----	50 LBS
<hr/>		
TOTAL WEIGHT	-----	874 LBS (APPROX)
CUBE	-----	9.6 CU FT (APPROX)

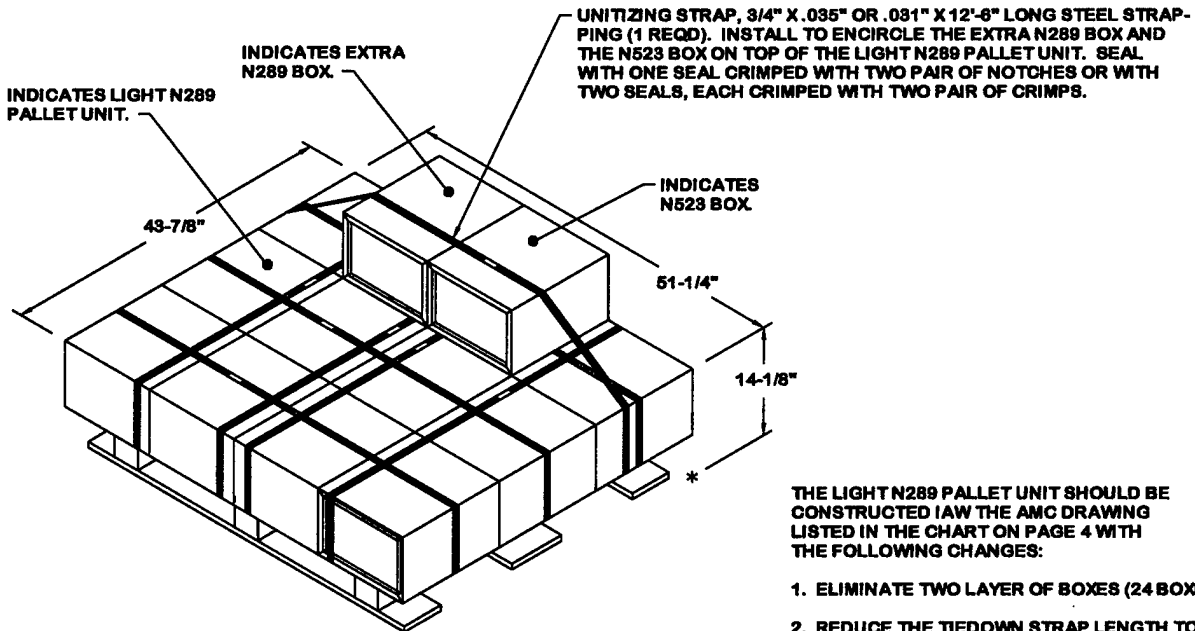

THE LIGHT N289 PALLET UNIT SHOULD BE CONSTRUCTED IAW THE AMC DRAWING LISTED IN THE CHART ON PAGE 4 WITH THE FOLLOWING CHANGES:

1. ELIMINATE TWO LAYER OF BOXES (24 BOXES).
2. REDUCE THE TIEDOWN STRAP LENGTH TO 9'-10".
3. REDUCE THE LOAD STRAP LENGTH TO 11'-1".

SPECIAL NOTE:

ALIGN THE TWO EXTRA BOXES WITH THE OUTER CENTER BOXES ON THE PALLET UNIT. INSTALL THE UNITIZATION STRAP OVER THE TWO BOXES, TOWARDS THE CENTER OF THE PALLET UNIT, AS SHOWN ABOVE.

LIGHT N289/N523 COMBINATION PALLET UNIT DETAIL

13 BOXES OF FUZES (16 PER BOX) AT 40 LBS	-----	480 LBS (APPROX)
1 LIGHT BOX OF PRIMERS (200 PER BOX) AT 25 LBS	-----	25 LBS (APPROX)
DUNNAGE	-----	9 LBS
PALLET	-----	80 LBS
<hr/>		
TOTAL WEIGHT	-----	594 LBS (APPROX)
CUBE	-----	29.7 CU FT (APPROX)

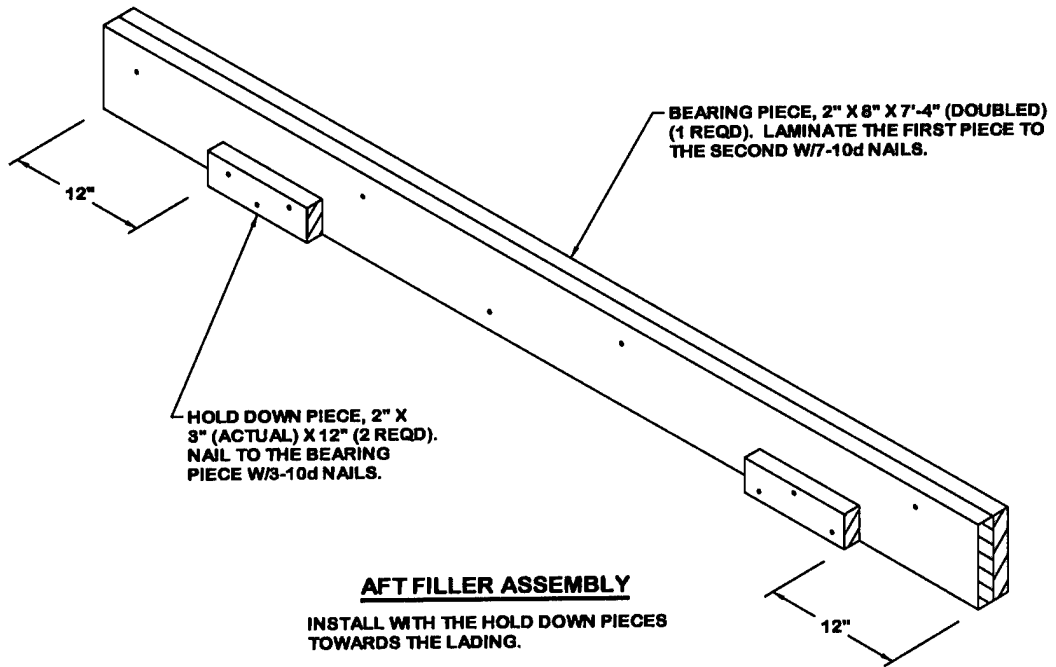

AFT FILLER ASSEMBLY

INSTALL WITH THE HOLD DOWN PIECES TOWARDS THE LADING.

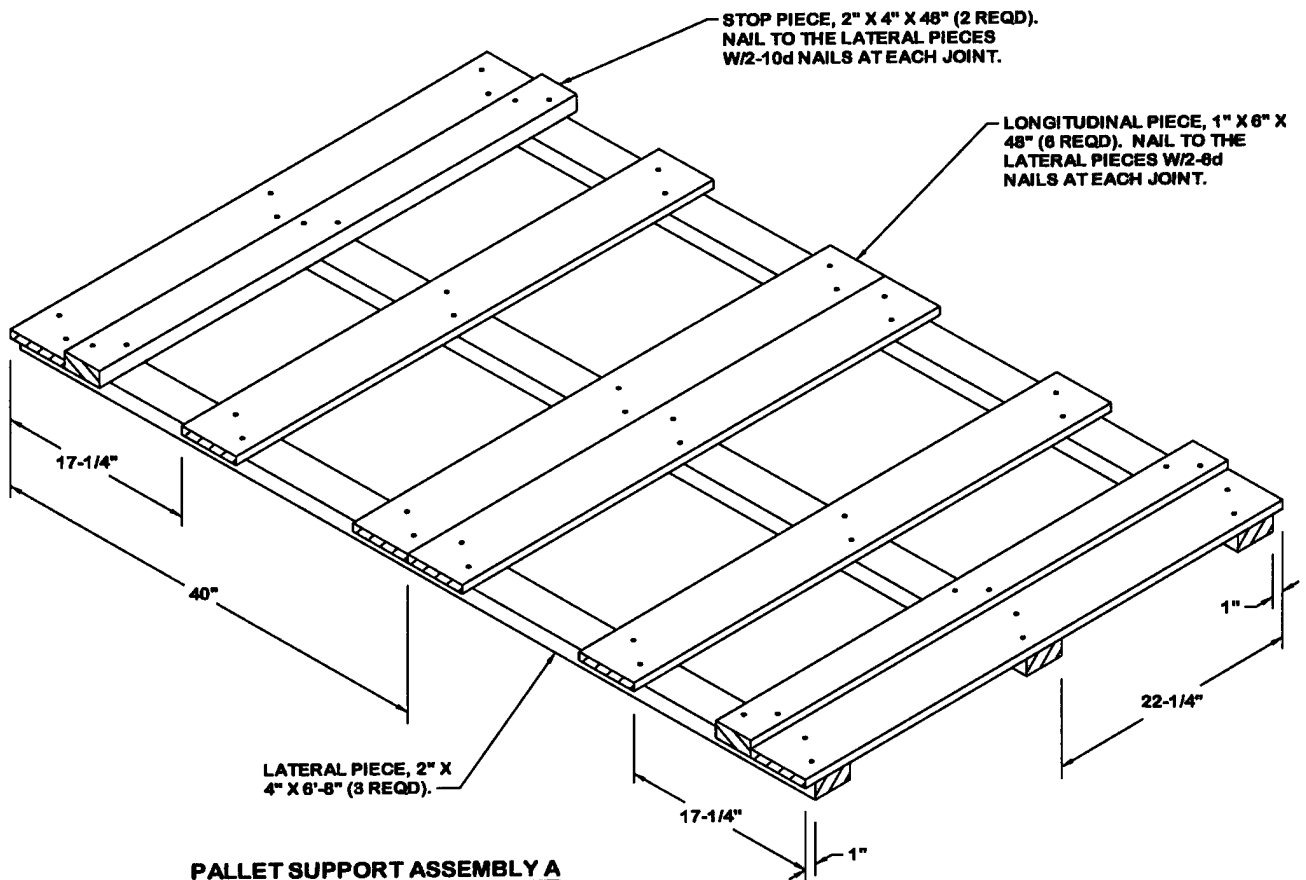

PALLET SUPPORT ASSEMBLY A

NOTE: THE LONGITUDINAL PIECES MUST NOT CONTACT THE TOP OF THE LIFTING RINGS OF THE D563 PALLET UNITS. IF THE SINGLE 2" X 4" LATERAL PIECES DO NOT PROVIDE SUFFICIENT CLEARANCE FOR THE D563 LIFTING RINGS, ADDITIONAL PIECES MAY BE ADDED. LAMINATE AN ADDITIONAL 1" OR 2" PIECE TO EACH LATERAL PIECE AS NEEDED TO CLEAR THE LIFTING RINGS.

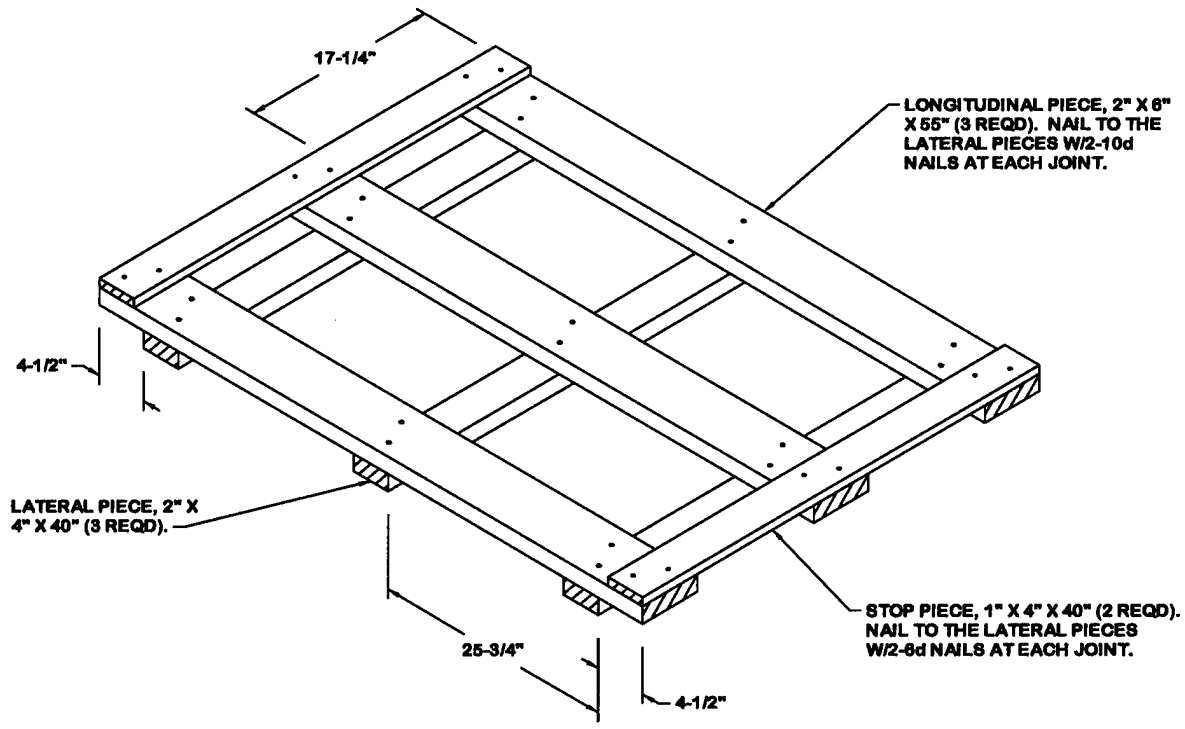

PALLET SUPPORT ASSEMBLY B

NOTE: THE LONGITUDINAL PIECES MUST NOT CONTACT THE TOP OF THE LIFTING RINGS OF THE D563 PALLET UNITS. IF THE SINGLE 2" X 4" LATERAL PIECES DO NOT PROVIDE SUFFICIENT CLEARANCE FOR THE D563 LIFTING RINGS, ADDITIONAL PIECES MAY BE ADDED. LAMINATE AN ADDITIONAL 1" OR 2" PIECE TO EACH LATERAL PIECE AS NEEDED TO CLEAR THE LIFTING RINGS.

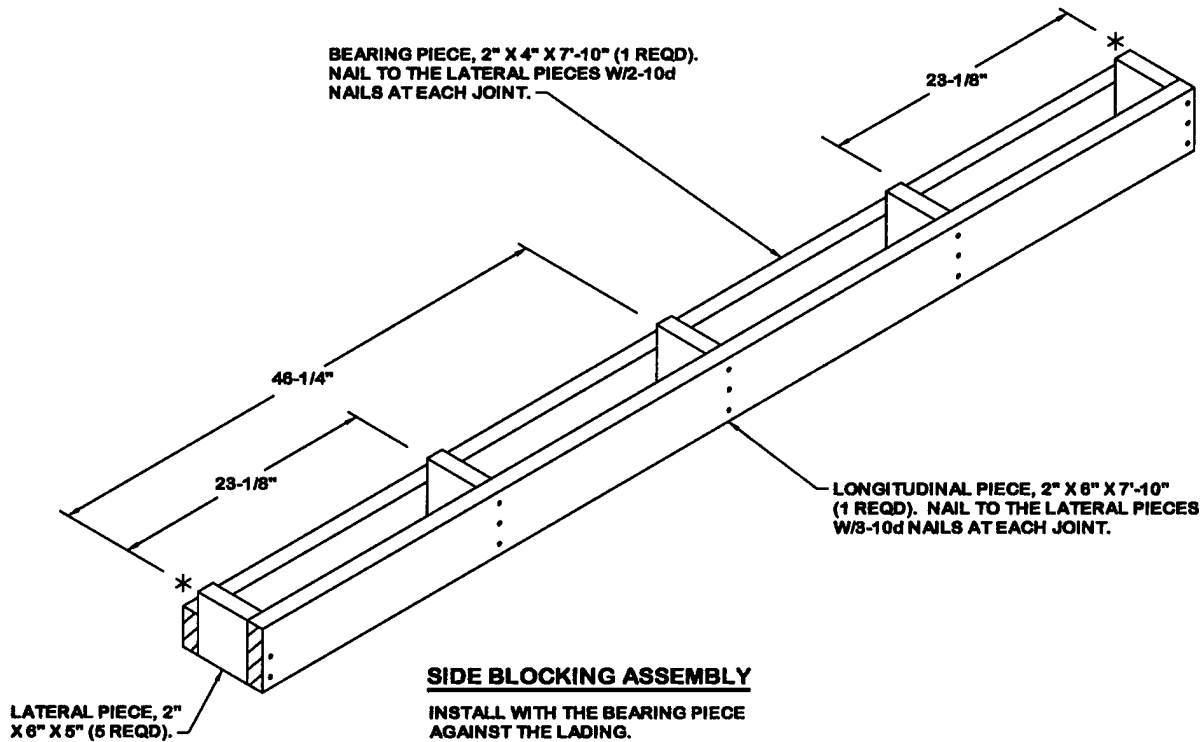

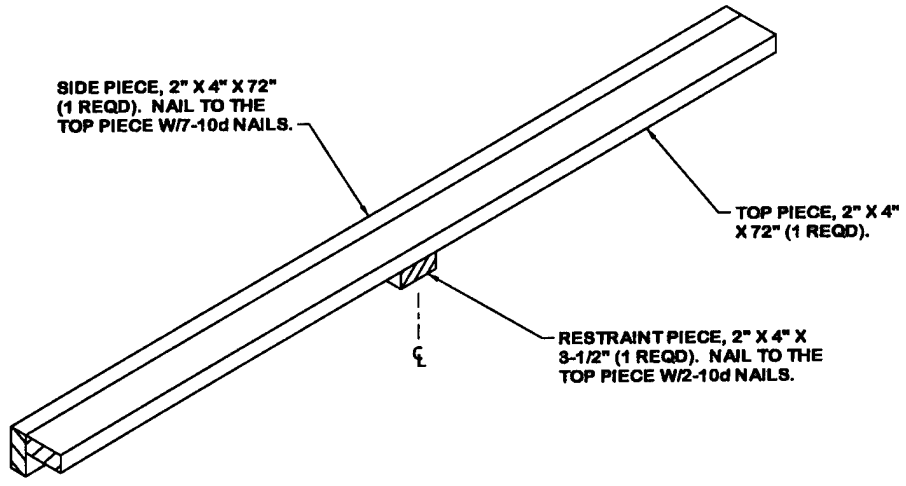

STRAPPING BOARD ASSEMBLY A

INSTALL WITH THE RESTRAINT PIECE POSITIONED BETWEEN THE TWO LIGHT D541 PALLET UNITS.

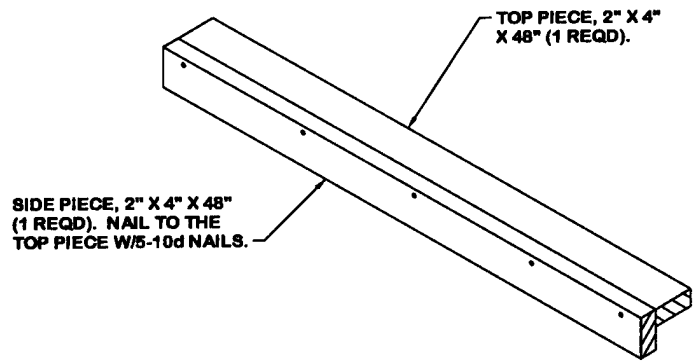

STRAPPING BOARD ASSEMBLY B

NOTE: THE ASSEMBLY SHOWN ABOVE IS ROTATED 180° FROM THE ORIENTATION IT WILL BE INSTALLED IN FOR CLARITY PURPOSES.

