

PENNSSTATE



Applied Research Laboratory

Water Tunnel Downstream Array (ARL No. 02-16) Design and Test Report

C. W. Allen, E. C. Myer, B. L. Kline

Technical Memorandum
File No. 02-080
SE02-192
27 October 2003

Copy No. //

20031119 139

Approved for Public Release; Distribution is Unlimited

Applied Research Laboratory
P.O. Box 30
State College, PA 16804

Contracted by the Department of the Navy
Naval Sea Systems Command
ONR Grant No. N00014-01-1-0311

WATER TUNNEL DOWNSTREAM ARRAY (ARL NO. 02-16) DESIGN AND TEST REPORT

C. W. Allen, E. C. Myer, B. L. Kline

Technical Memorandum

File No. 02-080

SE02-192

27 October 2003

Issued as an IM on 17 August 2002

Abstract: A four-ring, broad band receive array was designed, fabricated, and tested by ARL Penn State to replace the existing downstream array in the large diameter water tunnel. The new array (ARL no. 02-16) provides a substantially larger frequency-operating band (0.5 to 200 kHz) than the previous array. The array is fabricated from 1-3 composite material and has four separate ring channels and a sum (all four rings) channel, which, along with the preamplifier, incorporates amplitude shading to provide low sidelobe levels (typically less than -30 dB). The array and preamplifier exhibits low noise levels that are less than 20 dB re: $\mu\text{Pa}/\text{Hz}^{1/2}$ for the sum channel over the majority of the operating band.

Acknowledgement: This material is based upon work supported by Office of Naval Research through the Naval Sea Systems Command under Grant No. N00014-01-1-0311, Instrumentation and Equipment Upgrades to Improve Acoustical and Fluid Dynamic Measurements in the Garfield Thomas Water Tunnel.

Disclaimer: Any opinions, findings and conclusions, or recommendations expressed in this material are those of the authors and do not necessarily reflect the views of Dr. Patrick Purtell, ONR 333 or the Naval Sea Systems Command.

The contractor, the Pennsylvania State University, hereby certifies that, to the best of its knowledge and belief, the technical data delivered herewith under Grant No. N00014-01-1-0311 is complete, accurate, and complies with all requirement of the grant.

Date: 11/7/03

Name and Title of Certifying Official: 
Dr. E. G. Liszka, Director

TABLE OF CONTENTS

Abstract	i
List of Figures	ii
List of Tables	iii
List of Appendices	iii
List of References	iii
1.0 Introduction.....	1
2.0 Array Design	1
2.1 Array Mechanical Design	1
2.2 Electrical Design	3
2.3 Array Interface Information.....	3
2.4 Sum Channel Weights	4
3.0 Calibration Set-Up	5
4.0 Array Calibration Results.....	6
4.1 Array Capacitance	6
4.2 Array Receive Sensitivity.....	6
4.3 Array Directivity Measurements	8
4.4 Array Noise Measurements	9
5.0 Summary	10

LIST OF FIGURES

Figure 2-1: Sketch of Downstream Array Design.....	10
Figure 2-2: Downstream Array Assembly	11
Figure 2-7: Preamplifier Summing Stage	14
Figure 2-8: Preamplifier Output Stage.....	14
Figure 2-9: Remote Programmable Gain Circuit.....	15
Figure 4-1: Receive Response for All Channels, 0dB Gain, 5 to 200 kHz.....	15
Figure 4-2: Receive Response, Sum Channel, Variable Gains, 5 to 200 kHz.....	16
Figure 4-3: Receive Response, Channel No. 1, Variable Gains, 5 to 200 kHz.....	16
Figure 4-4: Receive Response, Channel No. 2, Variable Gains, 5 to 200 kHz.....	17
Figure 4-5: Receive Response, Channel No. 3, Variable Gains, 5 to 200 kHz.....	17
Figure 4-6: Receive Response, Channel No. 4, Variable Gains, 5 to 200 kHz.....	18
Figure 4-7: Receive Response, All Channels, 0.5 to 10 kHz.....	18

Figure 4-8: Measured Directivity Pattern, Sum Channel, 5 kHz, 0° Roll Angle.....19

Figure 4-9: Measured Directivity Pattern, Sum Channel, 10 kHz, 0° Roll Angle.....20

Figure 4-10: Measured Directivity Pattern, Sum Channel, 20 kHz, 0° Roll Angle.....21

Figure 4-11: Measured Directivity Pattern, Sum Channel, 50 kHz, 0° Roll Angle.....22

Figure 4-12: Measured Directivity Pattern, Sum Channel, 75 kHz, 0° Roll Angle.....23

Figure 4-13: Measured Directivity Pattern, Sum Channel, 100 kHz, 0° Roll Angle.....24

Figure 4-14: Measured Directivity Pattern, Sum Channel, 150 kHz, 0° Roll Angle.....25

Figure 4-15: Measured Directivity Pattern, Sum Channel, 200 kHz, 0° Roll Angle.....26

Figure 4-16: Measured Directivity Pattern, Sum Channel, 50 kHz, -75° Roll Angle.....27

Figure 4-17: Measured Directivity Pattern, Sum Channel, 100 kHz, -75° Roll Angle.....28

Figure 4-18: Measured Directivity Pattern, Sum Channel, 200 kHz, -75° Roll Angle.....29

Figure 4-19: Measured Directivity Pattern, Channels 1 Through 4 Summed on ATAR System
(Area Corrected Only), 50 kHz, 0° Roll Angle.....30

Figure 4-20: Measured Directivity Pattern, Channels 1 Through 4 Summed on ATAR System
(Full Weighting), 50 kHz, 0° Roll Angle.....31

Figure 4-21: Noise for All Channels, 0 to 200 kHz.....32

Figure 4-22: Noise for All Channels, 0 to 20 kHz.....32

LIST OF TABLES

Table 1-1. Downstream Array Requirements1

Table 2-1. Pin out for Array, Junction Box Connector, Preamplifier, and Output Cable.....4

Table 2-2. Array Weights.....5

Table 4-1. Measured Array Capacitance and Estimated Channel Loss6

Table 4-2. Receive Sensitivities vs. Frequency Measurements for Various Gain Settings7

Table 4-3. Description of Array Receive Sensitivity Calibration Figures7

Table 4-4. Sum Channel Receive Sensitivities at Each Gain Setting for 25 and 200 kHz.....8

Table 4-5. Summary of Array Sum Channel Directivity Parameters.....9

LIST OF APPENDICES

Appendix I. List of Test Data Files.....33

LIST OF REFERENCES

- (2.) “Microwave Scanning Antennas”, R. C. Hansen, Pages 64-67, Peninsula Publishing, 1985.

1.0 Introduction

The downstream array is utilized to measure acoustic radiation from various bodies being tested in the large diameter water tunnel. The previous downstream array (CATS array) consisted of 37 longitudinal resonator transducer elements that had a limited frequency band of operation from about 10 to 40 kHz. There are currently many applications where it is desired to measure acoustic radiation at frequencies anywhere from 0.5 to 200 kHz. Another desirable feature is to form beams with low sidelobes, especially at high incidence angles, in order to reduce the reception of noise and acoustic reflections from the tunnel walls. It is also important to reduce the array self noise in order to receive very low-level acoustic signals. The array aperture was kept the same as the previous array in order to meet cost constraints. Since the array aperture remained the same, the existing shell and array mounting hardware were to be utilized for the new array.

The general downstream array requirements are given below in Table 1-1.

Table 1-1. Downstream Array Requirements

Parameters	Array Requirements
Operating frequency - receive only (kHz)	0.5 to 200
Aperture diameter – maximum (inches)	9.5
Side lobe levels	Shaded to obtain low levels
Peak pressure with gain (dB re:μPa/Hz ^{1/2})	180
Self-noise (dB re:μPa/Hz ^{1/2}) (continuous function defined by these points)	56 @ 0.5 kHz 40 @ 12 kHz 0 @ 50 kHz -5 @ 200 kHz
Steering	None

Preamplifier electronics were required to reduce cable loss to acceptable values for each array channel, to provide a channel with all the rings summed together, and provide variable gains to meet the dynamic range requirements.

2.0 Array Design

2.1 Array Mechanical Design

The downstream array (ARL no. 2-16) consists of 1-3 composite active transducer material, lead/urethane attenuative backing, a stainless-steel mounting plate, a polyurethane window, and

an aluminum shell (see Figures 2-1 and 2-2). The array design details are documented in ARL drawing no. 117471. The array aperture consists of an 8.80-inch diameter disk of 1-3 composite (25% PZT5H volume fraction, shore D 80 matrix with phenolic microspheres) fabricated by Material Systems, Incorporated. The disk is 0.25 inches thick with a thickness resonance around 200 kHz. The array is made up of four concentric rings with active outer diameters of:

- Ring one (inner) = 2.16 inches
- Ring two = 4.33 inches
- Ring three = 6.49 inches
- Ring four (outer) = 8.65 inches

The rings have separate electrodes for both high and low electrical connections (electrode rings on both sides of the array).

Several noise control features have been incorporated into this new array design. First, the 1-3 composite array is mounted in a lead/urethane backing to absorb sound energy coming from behind the array. It is 1.33 inches thick directly behind the array and has a 0.25-inch border around the array edge to reduce lateral modes in the 1-3 composite. Twisted shielded wires are connected to both sides of the array and brought through holes in the backing. Secondly, the array backing assembly is mounted to a 0.84-inch thick stainless steel backing plate. The backing plate was designed to be as massive as possible to reduce structural vibration energy transferred from the shell. The output wires are brought through the backing plate into a junction box and terminated at a waterproof connector. The array is completely sealed from water intrusion via the waterproof connector, and O-ring seals in the junction box and back plate, in case the array is flooded.

The array assembly is bolted into the shell from the back. The backing plate is acoustically isolated from the shell by using a 1/8-inch thick neoprene gasket between the backing plate and the shell flange, and by using nylon washers between the bolts and the backing plate. The array shell was produced by modifying an existing CATS shell. The shell was found to be slightly different than the CATS shell drawing (D70333). The length was slightly off which affected the contour of the back end of the shell (by the joint). The shell was cleaned up by machining one to two mils off all the surfaces. A few gouges and scratches were present near the back of the shell and were almost completely removed by sanding and polishing. The shell was then hard anodized for long-term corrosion protection. A polyurethane window was potted onto the array and the shell, and machined to the required contour (see drawing no. 117472).

The array is electrically shielded by a copper mesh screen in front of the array and sheets of copper clad Kapton on the sides and back of the array. The copper screen in front of the array is potted in the polyurethane window. A sheet of copper clad Kapton is wrapped around the sides of the 1-3 composite and the backing, and is electrically connected to the front screen. A sheet of copper clad Kapton is bonded between the backing and the backing plate, and electrically connected to the side screen. The array shield is connected to a single wire and brought out separately to the preamplifier through the junction box waterproof connector. All the array outputs (rings 1 through 4) are connected via four twisted shielded pair cables (one per ring).

2.2 Electrical Design

The array consists of four output channels, rings one (inner) through four (outer). Each channel consists of a high, low, and shield. The high connection is made at the front of the array (water side) and the low connection is made at the back of the array. The connection is made using twisted shielded pair wire, with the shield floating at the array. The cables are connected to a 10 pin underwater connector (Impulse MSSJ-10-BCR) with all the cables shields tied together and brought out on a separate pin. The array shield wire is also connected to a pin of its own. The array is electrically connected to the preamplifier electronics via a non-waterproof cable consisting of a waterproof in-line connector (Impulse MSSJ-10-CCP), four twisted-shielded pair wires, and two single conductor insulated wires. The twisted-shielded pair wires have individual three-pin in-air connectors, and the two single conductor wires have banana plug connectors. The wiring diagram from the array to the preamplifier is shown in Figure 2-3.

The preamplifier electronics consist of four identical input circuits for amplifying each of the four elements and one weighted amplifier for the sum channel. The first stage (see Figure 2-4) of the input circuits consist of a THS4031 100-MHz low noise amplifier set to a fixed gain of 20db and the first stage of the band pass filter. The output of the first stage is capacitively coupled into the second gain stage, a PGA103 digitally programmable gain amplifier which provides the gain steps of 0db, 20db and 40db (see Figure 2-5). The output then feeds into an OPA132 FET input wide bandwidth operational amplifier (see Figure 2-6) which provide the third gain stage and second active filter stage. The gain on the OPA132 is setup with a digitally programmable ADG441 four channel analog switch, which provides gain steps of -20db, 0db, 6db and 12db. The output of this stage is then capacitively coupled to both the final output stage for the individual element and the input of the sum channel. Each of the four elements feed into an OPA132 amplifier which is configured as a weighted summing amplifier (see Figure 2-7). The output is then fed into its final output stage. The final output stage for each of the individual elements and the sum channel are identical (see Figure 2-8) and consist of a THS4130 low noise fully differential amplifier. This amplifier was chosen to provide differentially driven output signal to help reduce common mode noise that can be a problem in applications with long cable length and noisy environments.

The remote programmable gain is controlled via a 15 pin connector that is mounted on the preamp enclosure. There are four digital data bits that are used for setting up the user selectable gains form 0db up to 72db. Each of the bits is optically coupled into the main preamp board for noise isolation (see Figure 2-9).

2.3 Array Interface Information

Mechanically, the array bolts onto the downstream array adaptor shell (drawing no. D86968), in the same manner as the CATS array. The array adaptor shell then bolts onto the water tunnel model. Electrically, the preamplifier has two output cables with "D" connectors. One output cable has the outputs of all four channels (rings one through four) and the sum channel (all four channels summed together). The sum channel applies weights to each channel to reduce the beam sidelobe levels, and then coherently sums them together to provide 9.8 dB higher signal output compared to a single channel. The weighting analysis is discussed in more detail in section 2.4.

The other output cable goes to a remote programmable gain switch box that controls the gain on all five channels. The available gains are 0, 20, 26, 32, 40, 46, 52, 60, 66, and 72 dB. The gain settings of 60, 66, and 72 are not flat above 150 kHz (see section 4.2). The pin out for the array, junction box connector, preamplifier, and output cable is shown in Table 2-1.

Table 2-1. Pin out for Array, Junction Box Connector, Preamplifier, and Output Cable

Array Channel	Junction Box Connector	Array/ Preamp Cable	Preamp Input Connectors	Preamp Channels	Preamp Output Connectors	Output Cables
CH1 (inner)-H	Pin 8	CH1-H	Connector 1, pin 1	CH1-H	2	Red with Black
CH1 (inner)-L	Pin 7	CH1-L	Connector 1, pin 2	CH1-L	3	Black with Red
	NC	CH1-S	Connector 1, pin 3	Ground	13,25	
CH2 (inner)-H	Pin 6	CH2-H	Connector 2, pin 1	CH2-H	4	White with Black
CH2 (inner)-L	Pin 5	CH2-L	Connector 2, pin 2	CH2-L	5	Black with White
	NC	CH2-S	Connector 2, pin 3	Ground	13,25	
CH3 (inner)-H	Pin 4	CH3-H	Connector 3, pin 1	CH3-H	6	Green with Black
CH3 (inner)-L	Pin 3	CH3-L	Connector 3, pin 2	CH3-L	7	Black with Green
	NC	CH3-S	Connector 3, pin 3	Ground		
CH4 (inner)-H	Pin 2	CH4-H	Connector 4, pin 1	CH4-H	8	Blue with Black
CH4 (inner)-L	Pin 1	CH4-L	Connector 4, pin 2	CH4-L	9	Black with Blue
	NC	CH4-S	Connector 4, pin 3	Ground		
CH1 thru CH4-S	Pin 9	CH1 thru CH4-S	Banana plug - Black	Ground	13,25	
Array Shield	Pin 10	Array Shield	Banana plug - White	Ground	13,25	
				SUM-H	10	Yellow with Black
				SUM-L	11	Black with Yellow
				+12 Volts DC	12	Brown with Black
				- 12 Volts DC	24	Orange with Black
				GND	13	Black with Brown
				GND	25	Black with Orange

2.4 Sum Channel Weights

The sum channel consists of the sum of all four array channels with the appropriate weights applied to compensate for the difference in array channel impedance (relative to ring area) and to shade the rings to reduce the beam sidelobe levels. The weights applied for the impedance correction and the sidelobe reduction, along with the total weights are shown in Table 2-2. The impedance correction weights are given by:

$$W_{area_i} = A_{ring_i} / A_{ring_4}$$

Where: W_{area_i} = Weight of individual ring (channel)

A_{ring_i} = Area of i^{th} ring (channel)

A_{ring_4} = Area of ring no. four

The weights for reducing the sidelobes were obtained from a shading function formulated specifically for concentric ring arrays (see reference 1). The values of b and n were chosen to reduce maximum sidelobe levels to a level of -33 dB. The equation for calculating the shading

function values is given by:

$$Wsh_i = (b + (1-(p_i/\pi)^2)^n) / (b + (1-(p_1/\pi)^2)^n) \text{ where: } \begin{matrix} b = 0.25 \\ n = 2.5 \end{matrix}$$

and $p_i = \pi R_{c_i} / (2R_4)$ where: R_{c_i} = radius of center of i^{th} ring
 R_4 = outer radius of outer ring

The combined weights are then obtained by multiplying the two weights together and normalizing the result by the channel with the highest weight (channel 2), as shown below:

$$Wt_i = (Warea_i \times Wsh_i) / (Warea_2 \times Wsh_2)$$

Table 2-2. Array Weights

Channel (Ring) No.	Area Weights	Shading Weights	Total Weights
1 (inner)	0.152	1.000	0.458
2	0.436	0.761	1.000
3	0.718	0.435	0.940
4 (outer)	1.000	0.225	0.678

3.0 Calibration Set-Up

The receive sensitivity, directivity pattern, and self-noise calibrations were all performed in the ARL Acoustic Test Facility. The array was connected to a 12 3/4-inch diameter test housing using the downstream array adaptor shell and another test interface shell (located in the ARL ATF) made specifically to test the downstream array. Two test cables made specifically for the new downstream array were used to electrically connect the preamplifier topside. The cables were brought out of the test housing bulkhead using Tygon tubing attached to a flange on the bulkhead.

The test cable assembly, two test cables, Tygon tubing, and bulkhead flange, are currently stored at the ARL Penn State Acoustic Test Facility. The test shells were then attached to a 12 3/4-inch test frame with the capability to manually vary the roll angle. Once the shells are attached, the array can be rolled in 15° increments. The following test conditions were used for all the measurements in the 5 to 200 kHz frequency range:

- distance from rotator pole to standard: 3.160 meters
- offset distance from rotator pole to array: 0.450 meters
- net distance from array to standard: 2.710 meters
- test depth: 2.375 meters
- operator: Greg Granville

In order to make measurements over a total frequency range of 0.5 to 200 kHz, three different standard acoustic transmitters were used. The standards used were: (1) EA33, both sections, for the 0.5 to 10 kHz range, (2) F33, inner section only, for the 5 to 50 kHz range, and (3) ARL Penn State 96-10 for the 50 to 200 kHz range. The data was corrected for the array offset of 0.45

meters for all receive response and directivity measurements.

For the measurements made in the low frequency range of 0.5 to 10 kHz, a different test set-up was used since only about one period of the received signal can be sampled at these low frequencies. Therefore, a long pulse method was used where the received pulse is sampled in the region of the pulse where reverberation is present. The data was then averaged over a specified frequency band to smooth out the peaks and nulls due to constructive and destructive interference. Also, the test separation distance between the array and the standard was shortened to 1.0 meters in order to reduce reverberation effects.

4.0 Array Calibration Results

The array calibration parameters, such as array capacitance, receive sensitivities (including the preamplifier), directivity patterns, and noise (including preamplifier), are provided in this section.

4.1 Array Capacitance

The capacitance of the four different array channels at the end of approximately two feet of cable (approximate distance from array to preamplifier) is shown in Table 4-1. The capacitance was measured at 1 kHz with the cable shields and the overall array shield attached to the low electrode of the array. There is some cable loss for each channel due to the cable and the parasitic capacitance of the array shield from the array to the connector. The tan delta parameter is the imaginary capacitance or resistive loss across each of the array elements. A value of 0.018 is expected for the 1-3 composite transducer material utilized.

Table 4-1. Measured Array Capacitance and Estimated Channel Loss

Channel	Capacitance (nF)	Tan Delta	Cable Loss (dB)
1 (inner)	2.45	0.018	-0.72
2	6.80	0.019	-0.47
3	11.04	0.019	-0.38
4 (outer)	15.60	0.018	-0.31

The cable loss was calculated by using the ratio of the array channel capacitances without any wires or shields to the capacitance of the array channels at the end of two feet of cable with the cable shields and the array shield tied to low. The difference in cable loss is insignificant between all the channels except for possibly channel one, and even this small error should not affect the array shading significantly, especially since channel one is the most heavily weighted element. The cable loss was not taken into account when the array weights were calculated, however, they could be if the individual channels are weighted and summed externally, which could result in lower sidelobe levels.

4.2 Array Receive Sensitivity

The receive sensitivity of all four channels and the weighted sum beam were measured over three

different frequency ranges and at selected preamplifier gains. The frequency ranges were 0.5 to 10 kHz, 5 to 50 kHz, and 50 to 200 kHz. The receive sensitivity of the sum channel was also measured for each gain setting at 25 and 200 kHz. The listing of the receive sensitivity vs. frequency measurements taken at various gain settings are shown in Table 4-2. All measurements were made at a 0° roll angle unless specified otherwise.

Table 4-2. Receive Sensitivities vs. Frequency Measurements for Various Gain Settings

Gain Settings (dB)	0.5 to 10 kHz	5 to 50 kHz	50 to 200 kHz	25 kHz	200 kHz
0	---	Sum,1,2,3,4	Sum,1,2,3,4	Sum	Sum
20	Sum	---	---	Sum	Sum
26	---	---	---	Sum	Sum
32	1,2,3,4 ¹	---	---	Sum	Sum
40	---	Sum,1,2,3,4	Sum,1,2,3,4	Sum	Sum
46	---	---	---	Sum	Sum
52	---	---	---	Sum	Sum
60	---	Sum,1,2,3,4	Sum,1,2,3,4	Sum	Sum
66	---	---	Sum,1,2,3,4 ¹	Sum	Sum
72	---	---	Sum,1,2,3,4 ¹	Sum	Sum

¹Measurements made at a -75° roll angle

All the receive response vs. frequency measurements behaved as expected and the gains were constant over the frequency operating bands except for the higher gain settings (60 dB and above). The majority of the receive response measurements were taken at a 0° roll angle, but some of the measurements were taken at a -75° roll angle. Measurements were taken at an arbitrary roll angle (-75°) to demonstrate that the beam properties were similar at all roll angles. After it was demonstrated that the on axis sensitivity (0° azimuth) was independent of roll angle, some unique sensitivity measurements were taken in this roll plane to save rigging time to change back to the 0° roll angle. The array receive sensitivity calibration curves for all channels for the frequency range from 5 to 200 kHz are shown in Figures 4-1 through 4-7 and Table 4-3 describes the contents of each figure.

Table 4-3. Description of Array Receive Sensitivity Calibration Figures

Figure No.	Frequency Range (kHz)	Channels	Gain Setting(s) (dB)	Roll Angle (deg)
4-1	5 - 200	Sum,1,2,3,4	0	0
4-2	5 - 200, 50 - 200 ¹	Sum	0,40,60,66 ¹ ,72 ¹	0 and -75 ¹
4-3	5 - 200, 50 - 200 ¹	1	0,40,60,66 ¹ ,72 ¹	0 and -75 ¹
4-4	5 - 200, 50 - 200 ¹	2	0,40,60,66 ¹ ,72 ¹	0 and -75 ¹
4-5	5 - 200, 50 - 200 ¹	3	0,40,60,66 ¹ ,72 ¹	0 and -75 ¹
4-6	5 - 200, 50 - 200 ¹	4	0,40,60,66 ¹ ,72 ¹	0 and -75 ¹
4-7	0.5 - 10	Sum,1,2,3,4	20(Sum), 32(1,2,3,4)	-75

¹Gain settings of 66 and 72 dB taken over 50 to 200 kHz frequency range and at -75° roll angle.

The sum channel receive sensitivity calibration measurements taken at every gain setting and at

frequencies of 25 and 200 kHz are given in Table 4-4. The intent of these measurements was to check out the preamplifier gain settings. The gains were referenced to the 20 dB gain setting since the 0 dB setting has a 10 dB attenuator in the circuit and is not considered to be as accurate as the other gain settings. The results of these measurements indicate that the response of the preamplifier is not flat at frequencies above 150 kHz and at gain settings above 52 dB. This effect was not unexpected and is documented in the receive response vs. frequency calibration curves for gain settings of 60, 66, and 72 dB shown in Figures 4-2 through 4-6. Based on these results it is important to note that the actual calibration curves for a particular gain setting should be used when taking measurements at gain settings at 60 dB or above and at frequencies above 150 kHz.

Table 4-4. Sum Channel Receive Sensitivities at Each Gain Setting for 25 and 200 kHz

Gain Setting (dB)	25 kHz		200 kHz	
	RR (dB V/ μ Pa)	Gain ¹ (dB)	RR (dB V/ μ Pa)	Gain ¹ (dB)
0	-180.1	0.20	-179.9	0.40
20	-160.3	---	-160.3	---
26	-154.2	25.9	-154.3	26.0
32	-148.3	31.8	-148.6	31.7
40	-140.1	40.0	-140.8	39.5
46	-134.2	45.9	-134.8	45.5
52	-128.4	51.7	-129.1	51.2
60	-120.2	59.9	-123.6	56.7
66	-114.2	65.9	-117.7	62.6
72	-108.4	71.7	-112.3	68.0

¹Gain relative to receive sensitivity measured for 20 dB gain setting.

An estimate of the receive sensitivity of the array channels (accurate to within +/- 3 dB) was obtained at frequencies from 0.5 to 10 kHz using the long pulse calibration method described in section 3.0. The receive sensitivity estimates from 0.5 to 10 kHz are shown in Figure 4-7. Due to the backing becoming more acoustically transparent at these low frequencies, the receive response has peaks and nulls due to interference from acoustic energy reflecting off the back plate.

4.3 Array Directivity Measurements

Sum channel directivity patterns were measured at various frequencies throughout the operating frequency range at 0° and -75° roll angles. A summary of the array sum channel directivity parameters at roll angles of 0° and -75° at various frequencies are shown in Table 4-5. The sum channel directivity patterns for frequencies 5, 10, 20, 50, 75, 100, 150, and 200 kHz are shown in Figures 4-8 through 4-15. The directivity patterns agree well with theory. The sidelobe levels are higher than predicted at the higher frequencies (100 to 200 kHz), which may be due to slight errors in the array flatness (about 0.007 inches) that occurred during construction. The beamwidths and sidelobe levels of the directivity patterns at the -75° roll angle measured at 50, 100, and 200 kHz agree fairly well with the pattern properties measured at the 0° roll angle, which suggests that the array pattern properties can be considered to be fairly constant with roll angle (see Figures 4-16 through 4-18).

Table 4-5. Summary of Array Sum Channel Directivity Parameters

Frequency (kHz)	0° Roll Angle					-75° Roll Angle				
	BW (deg)		SLL (dB)		BR ¹ (dB)	BW (deg)		SLL (dB)		BR ^{1,2} (dB)
	Meas.	Theor.	Meas.	Theor.		Meas.	Theor.	Meas.	Theor.	
1	---	129.0	---	---	---	189.0	129.0	---	---	0
5	71.8	84.0	---	---	-17	---	---	---	---	---
10	42.7	47.0	---	---	-30	---	---	---	---	---
20	23.6	24.0	-34.3	-36.0	-43	---	---	---	---	---
50	9.5	9.7	-32.0	-33.0	< -50	9.7	9.7	-28.5	-33.0	---
75	6.5	6.0	-30.7	-32.0	< -50	---	---	---	---	---
100	4.9	4.8	-28.4	-31.0	< -50	5.1	4.8	-26.3	-31.0	---
150	3.5	3.2	-28.0	-31.0	< -50	---	---	---	---	---
200	2.7	2.4	-23.0	-31.0	< -50	2.7	2.4	-24.6	-31.0	---

¹Back response (maximum response from 90° to 270°).

²No back response data was taken for -75° roll angles at frequencies above 1 kHz.

Directivity patterns were measured with the four individual channels weighted topside using the ARL Penn State ATAR weighting system. The four individual channels (1 through 4) were connected to the ATAR system and summed together using weights to correct for the impedance (area) difference between the elements and then the total weights to achieve low sidelobe levels (-33 dB). In the case of the weights applied to just correct for the impedance differences, the theoretical pattern should be the same for a non-weighted circular aperture with a diameter of 8.65 inches. The directivity pattern measured at 50 kHz agrees well with the theoretical pattern. The measured beamwidth is 7.9° compared to the 8.2° theoretical value and the measured maximum sidelobe level is -17.0 dB compared to the -17.8 dB theoretical value (see Figure 4-19). For the case where the total weights were applied, the ATAR sum beam and the downstream electronics sum beam were almost exactly the same (see Figures 4-11 and 4-20). This indicates that the downstream array electronics are applying the correct weights in an accurate manner.

4.4 Array Noise Measurements

The measured noise performance of the downstream array is as expected and is excellent for a broadband receive array and preamplifier system, but it still did not meet the desired noise levels above 15 kHz (greater than 20 dB deficit). The measured array noise performance for all five channels is shown in Figure 4-21 for the frequency range from 0.5 to 200 kHz and Figure 4-22 for the frequency range from 0.5 to 20 kHz. The noise is dominated by preamplifier noise above 15 kHz, so the only way to improve the noise performance is to design a lower noise preamplifier, significantly increase the receive sensitivity of the array, and/or greatly increase the number of elements to realize a larger array gain against noise. The current preamplifier already utilizes state-of-the-art low noise voltage and current components and designs. It uses a low noise Op-Amp and sums together two Op-Amps at the input to reduce the signal-to-noise ratio by 3 dB. The array sensitivity is already very high for a broadband (non-resonant) acoustic receiver without overly decreasing the capacitance of the elements. The array could have been divided up into

many more elements (100 times more would be required for a 20 dB gain), but this would have substantially increased the cost by increasing the number of preamplifier channels required and complicated array fabrication. The current array and preamplifier design was chosen as a balanced tradeoff between desired performance and cost.

5.0 Summary

The array has the same aperture and housing as the previous downstream array, but it has a much larger frequency band of operation (0.5 to 200 kHz). The array consists of four concentric rings and is fabricated from 0.25-inch thick 1-3 composite material. The preamplifier has five outputs, which are the four individual rings and a sum channel (all four rings summed together). The sum channel amplitude weights the rings to provide a forward beam with low sidelobes (typically less than -30 dB). The individual ring channels can be used individually or externally summed together in different combinations or with various weightings to provide even lower sidelobe levels if desired. The newly fabricated broadband downstream array meets or exceeds performance expectations. The receive responses and directivity patterns are very close to theory. The noise levels are as expected, but are still about 20 dB higher than desired.

Acknowledgement

The array hardware described in this report was developed under ONR grant N00014-01-1-0311 administered by Dr. L. Patrick Purtell (ONR 333). The ARL principal investigators for the grant were R. C. Marboe and M. L. Billet.

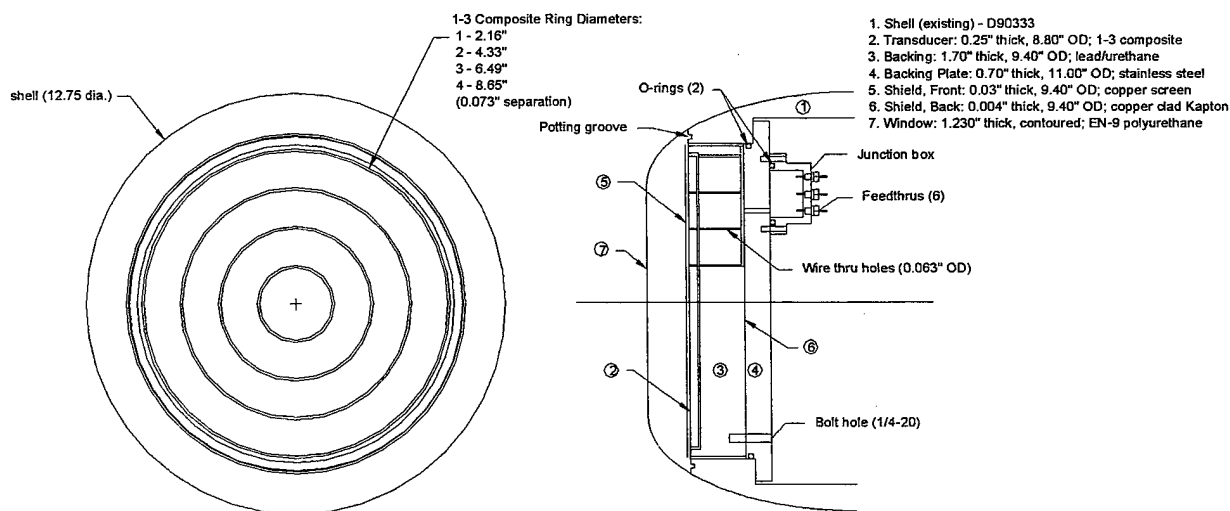
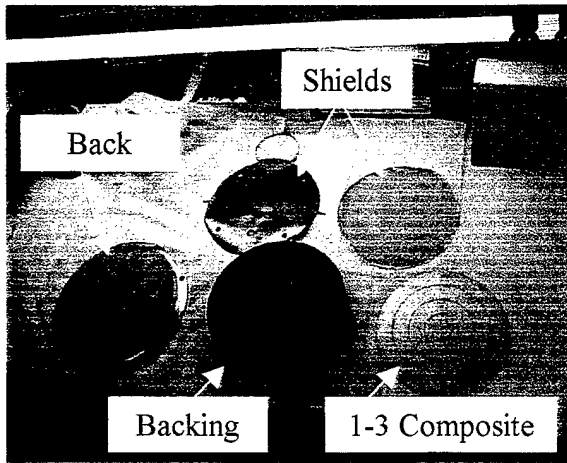
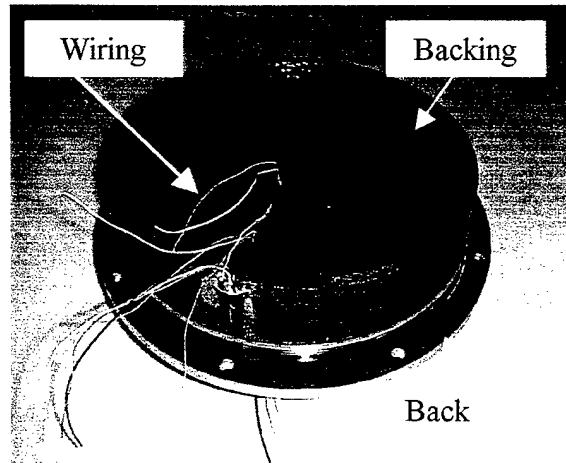

Figure 2-1: Sketch of Downstream Array Design



(a) Array Parts



(b) Backing/Backing Plate Assembly

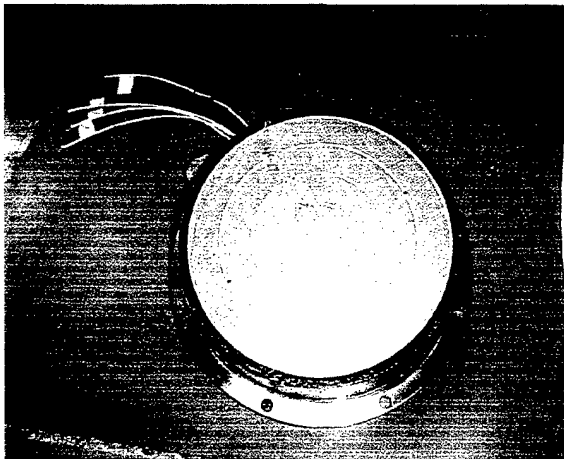

(c) Array Assembly w/o shields

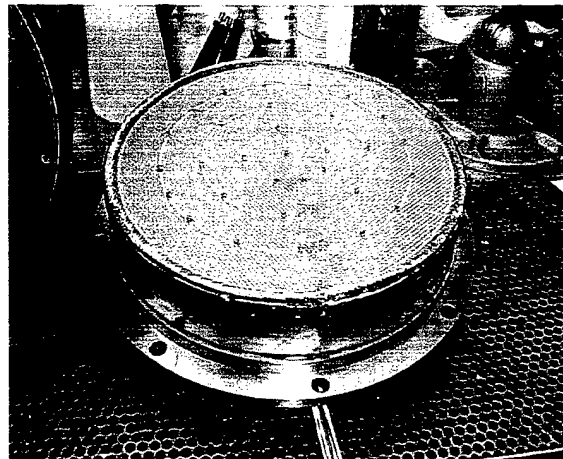

(d) Array Assembly with shields

Figure 2-2: Downstream Array Assembly

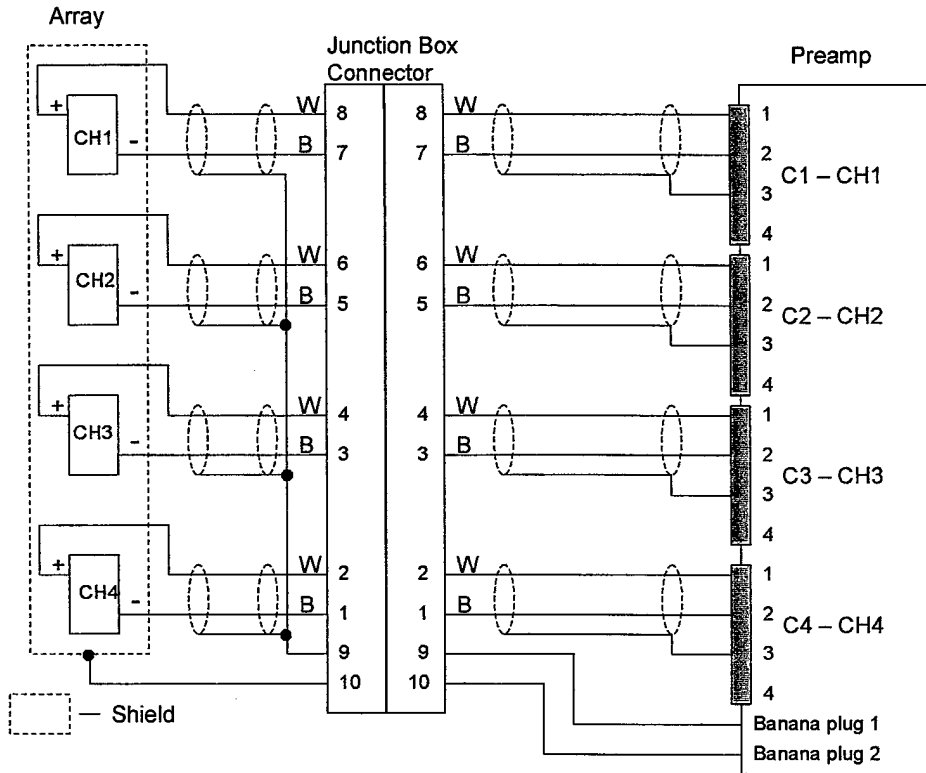

Figure 2-3: Wiring Diagram of Array/Preamp Interface

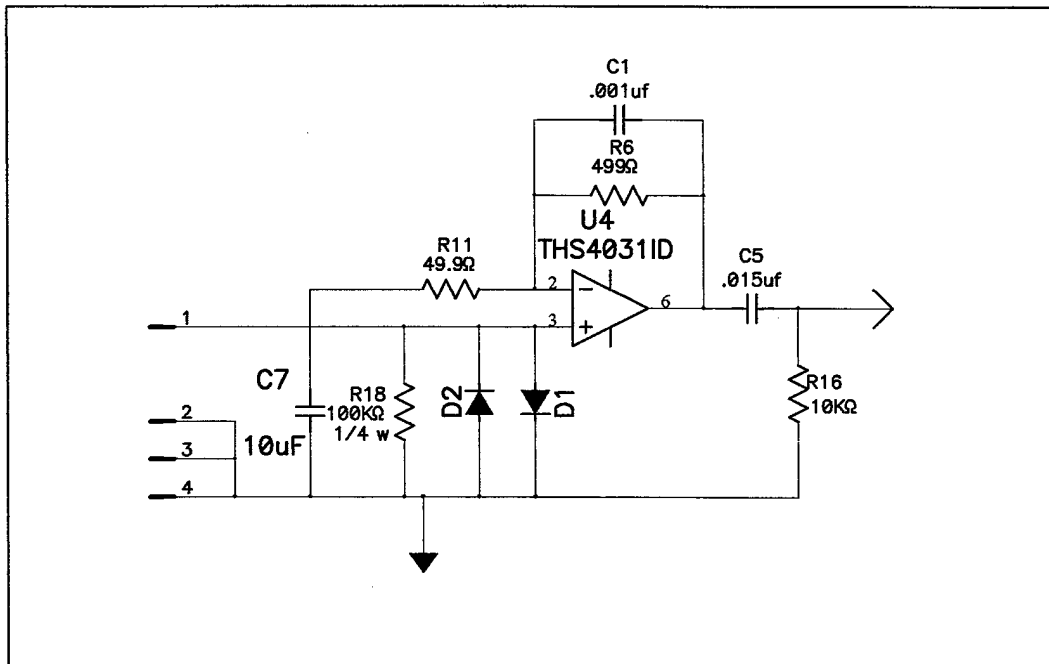

Figure 2-4: Preamplifier First Stage

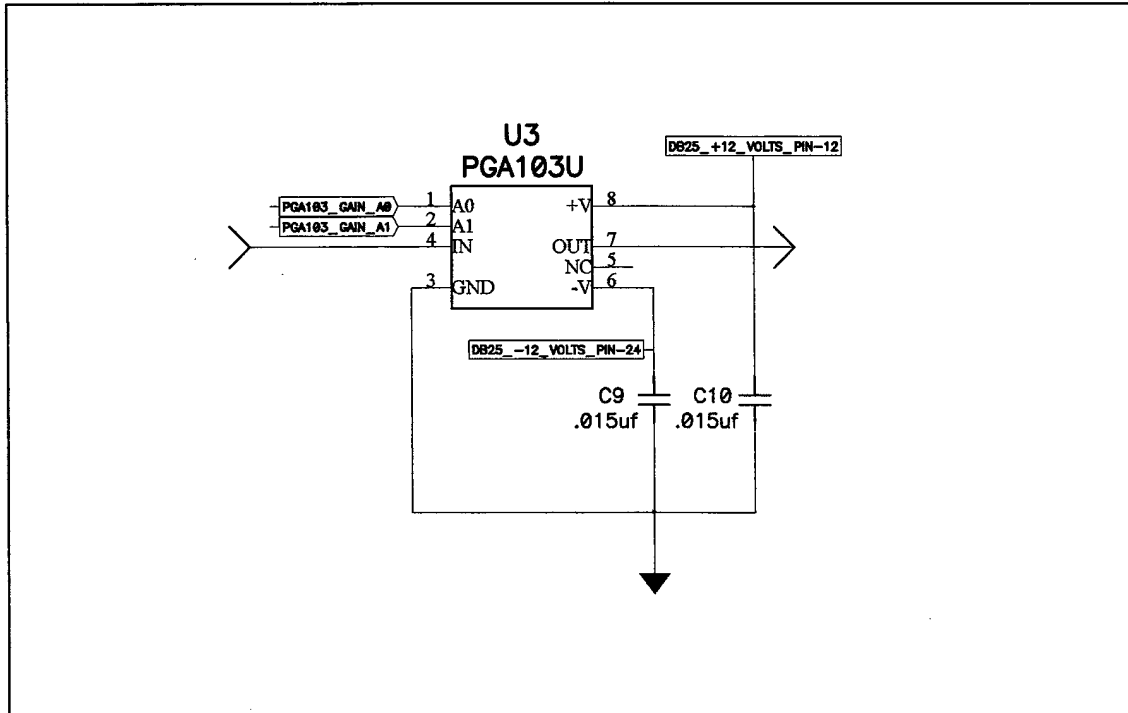

Figure 2-5: Preamp Second Stage

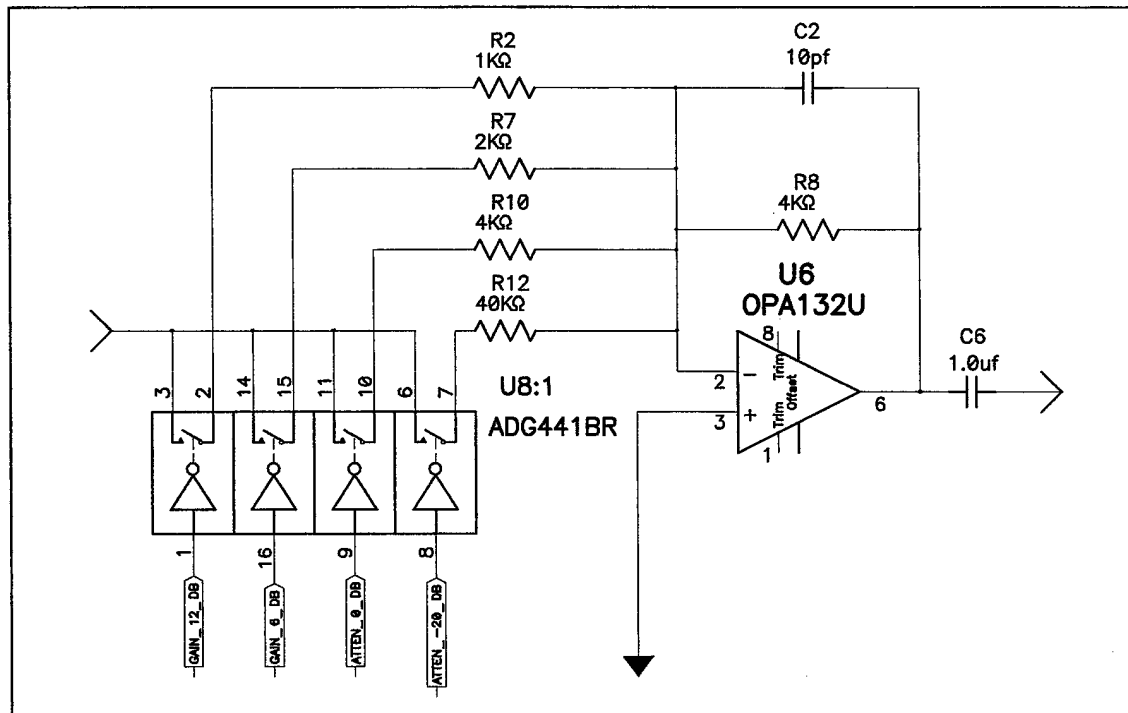

Figure 2-6: Preamp Third Stage

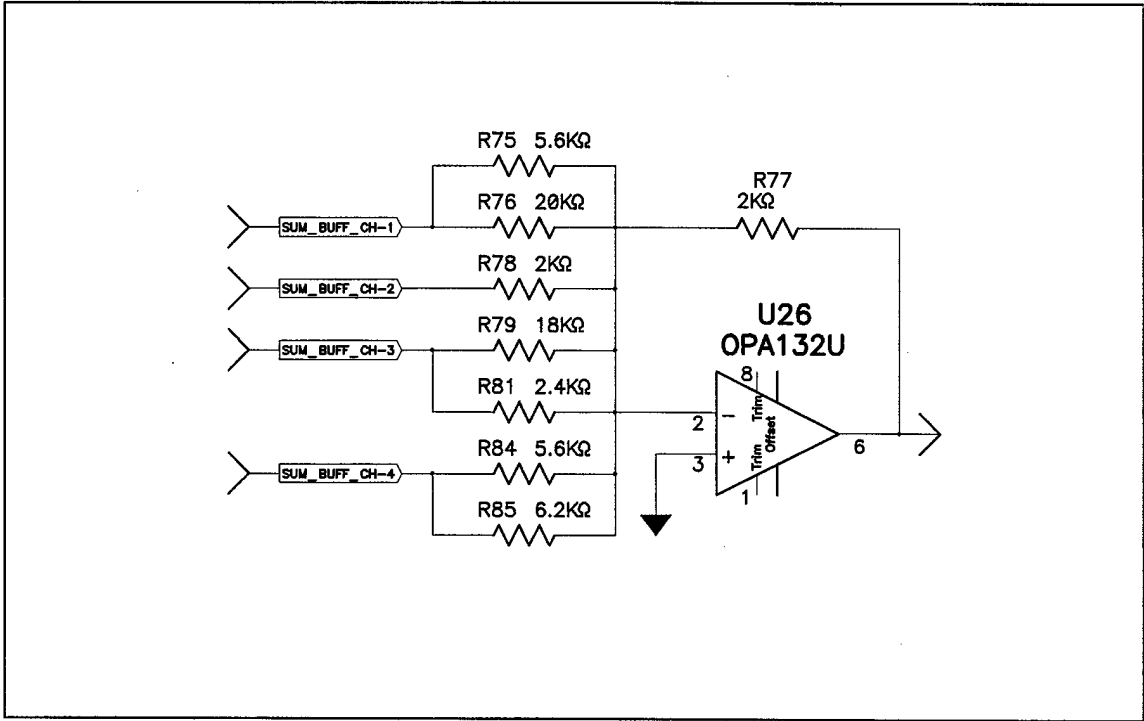

Figure 2-7: Preamplifier Summing Stage

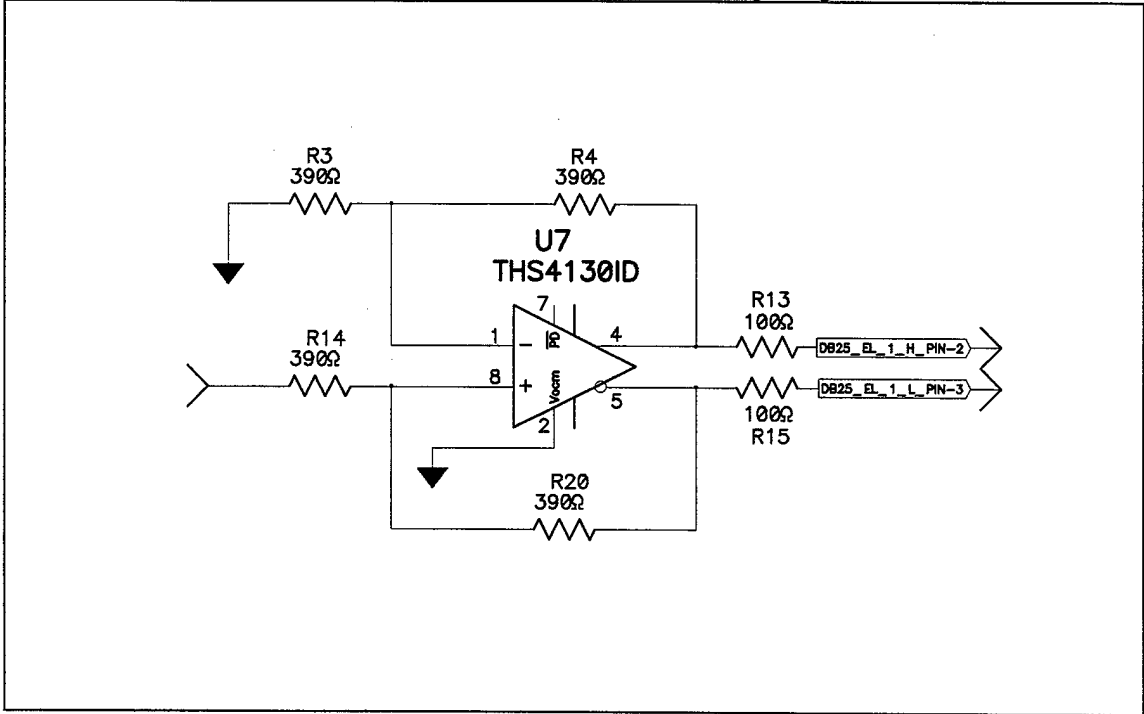

Figure 2-8: Preamplifier Output Stage

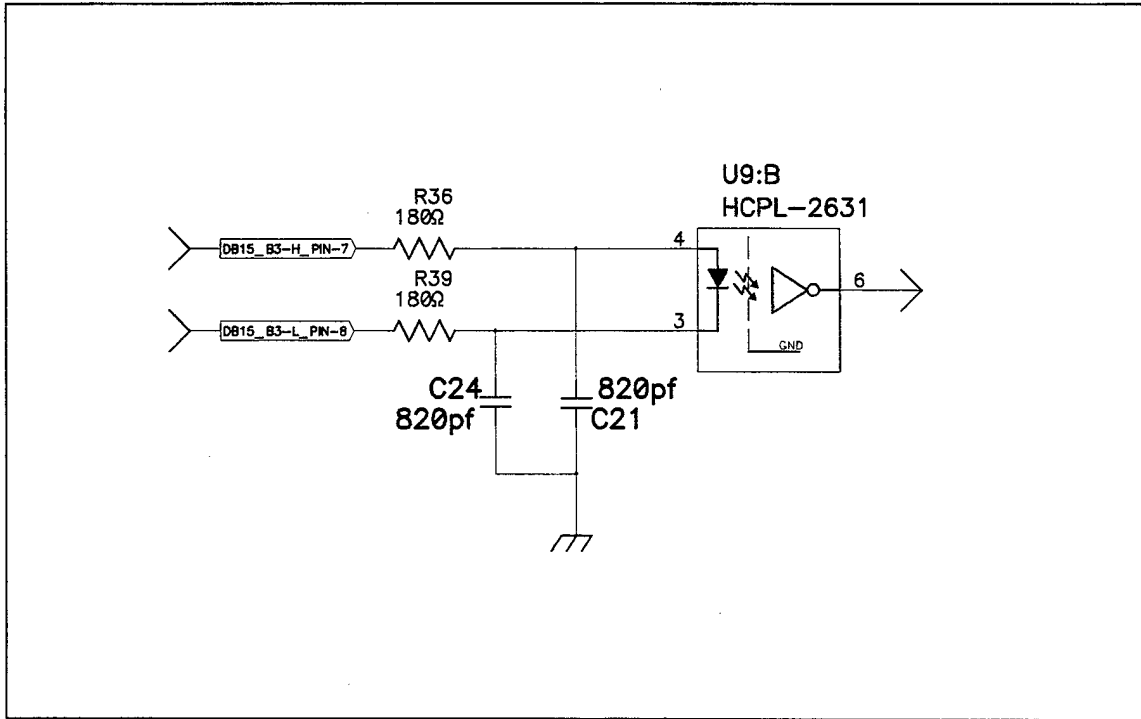

Figure 2-9: Remote Programmable Gain Circuit

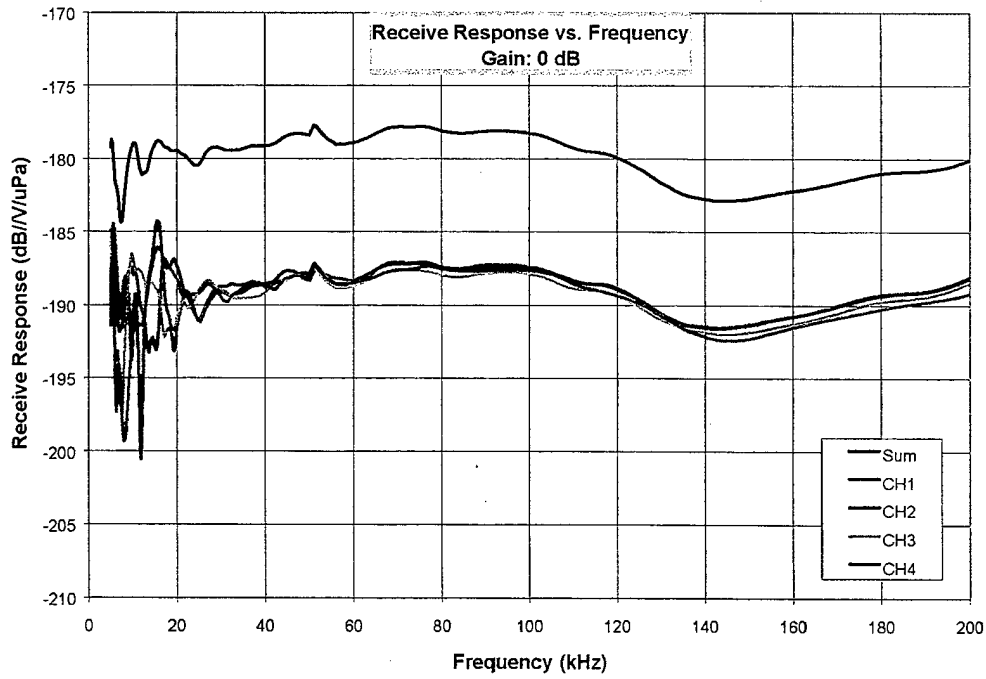

Figure 4-1: Receive Response for All Channels, 0 dB Gain, 5 to 200 kHz

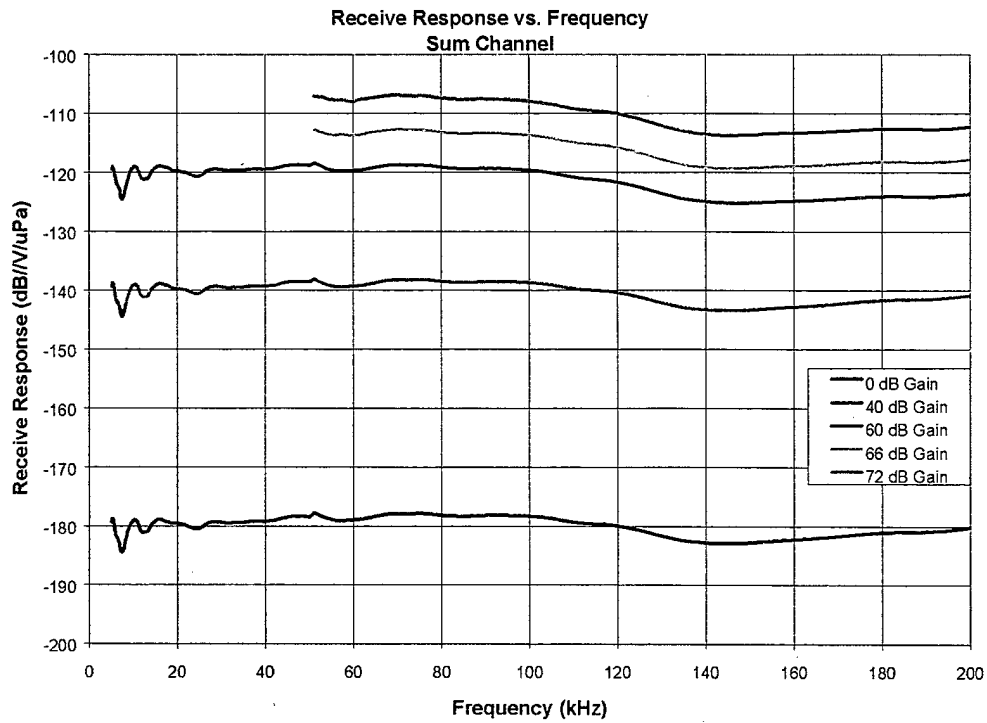

Figure 4-2: Receive Response, Sum Channel, Variable Gains, 5 to 200 kHz

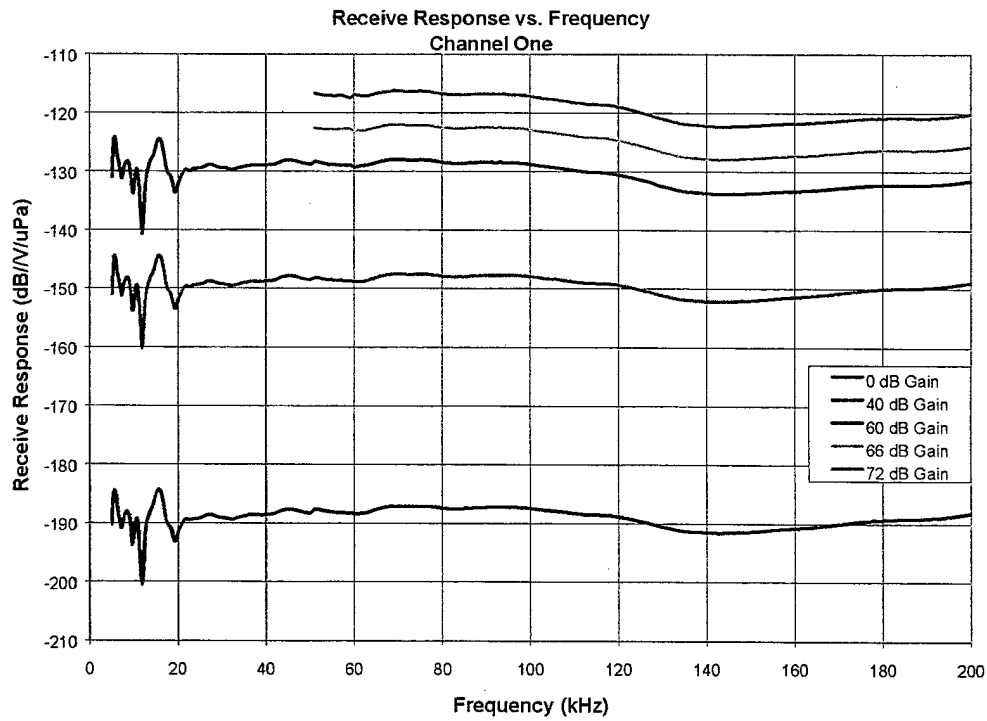

Figure 4-3: Receive Response, Channel No. 1, Variable Gains, 5 to 200 kHz

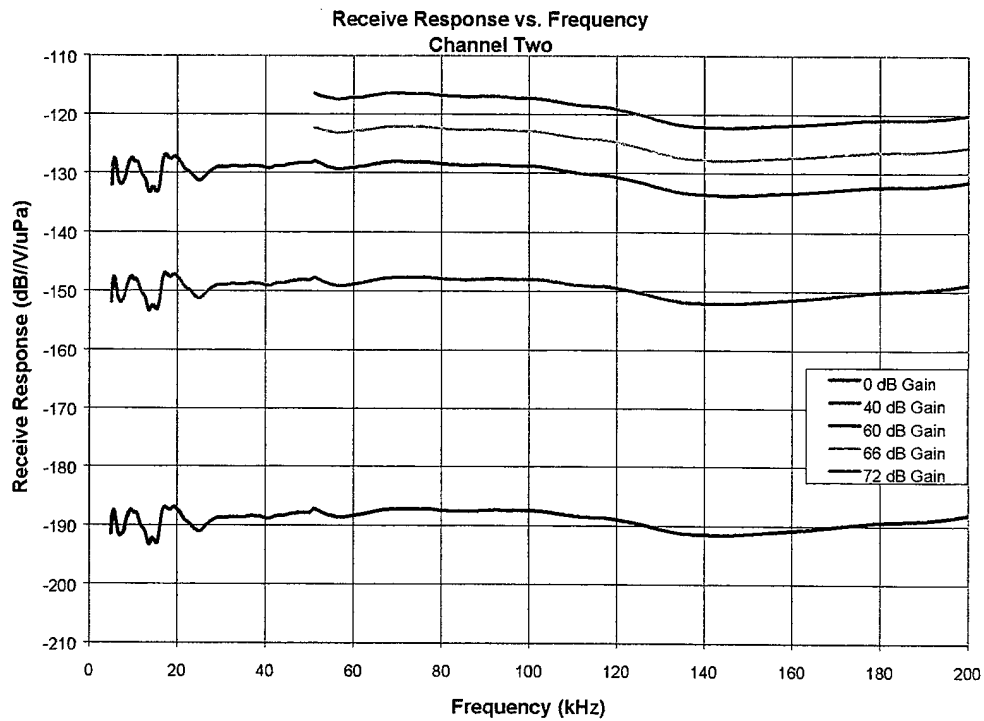

Figure 4-4: Receive Response, Channel No. 2, Variable Gains, 5 to 200 kHz

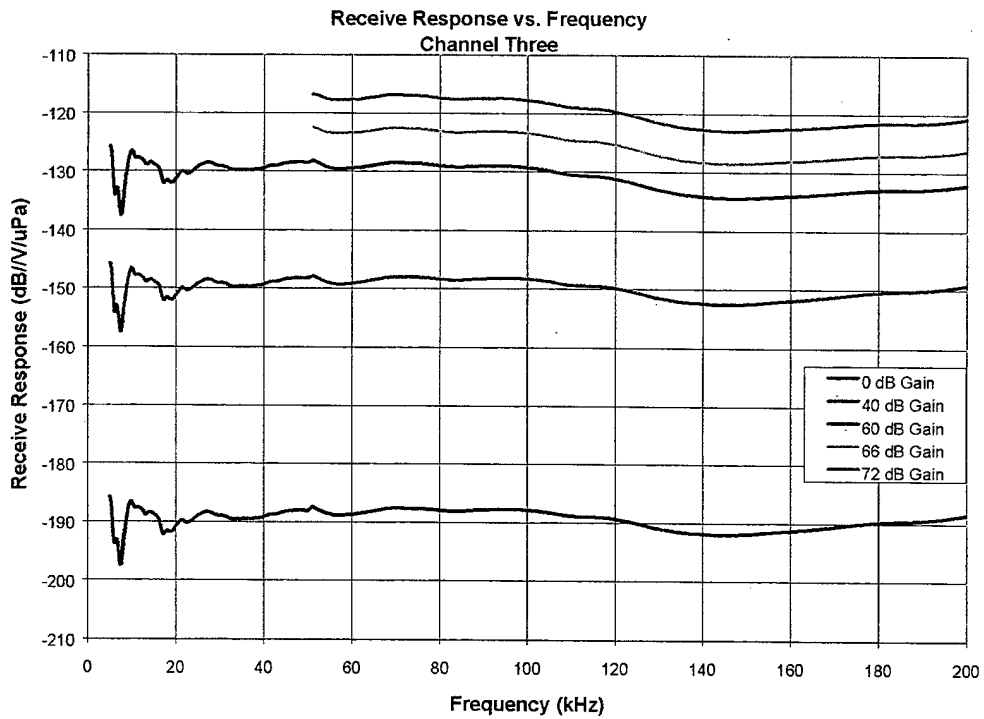

Figure 4-5. Receive Response, Channel No. 3, Variable Gains, 5 to 200 kHz

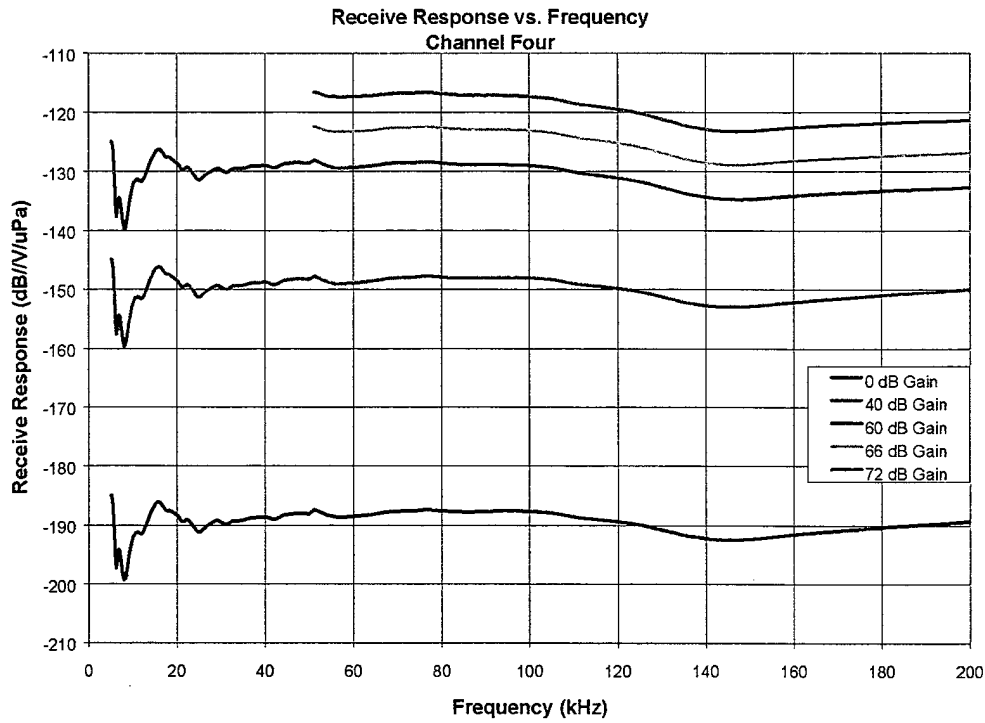

Figure 4-6: Receive Response, Channel No. 4, Variable Gains, 5 to 200 kHz

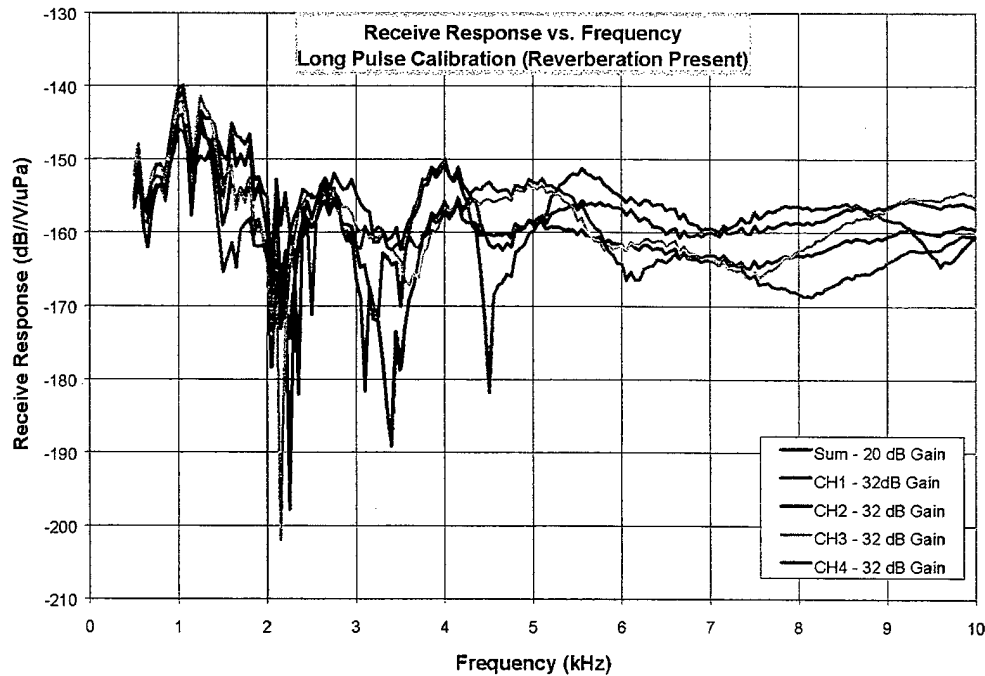

Figure 4-7: Receive Response, All Channels, 0.5 to 10 kHz

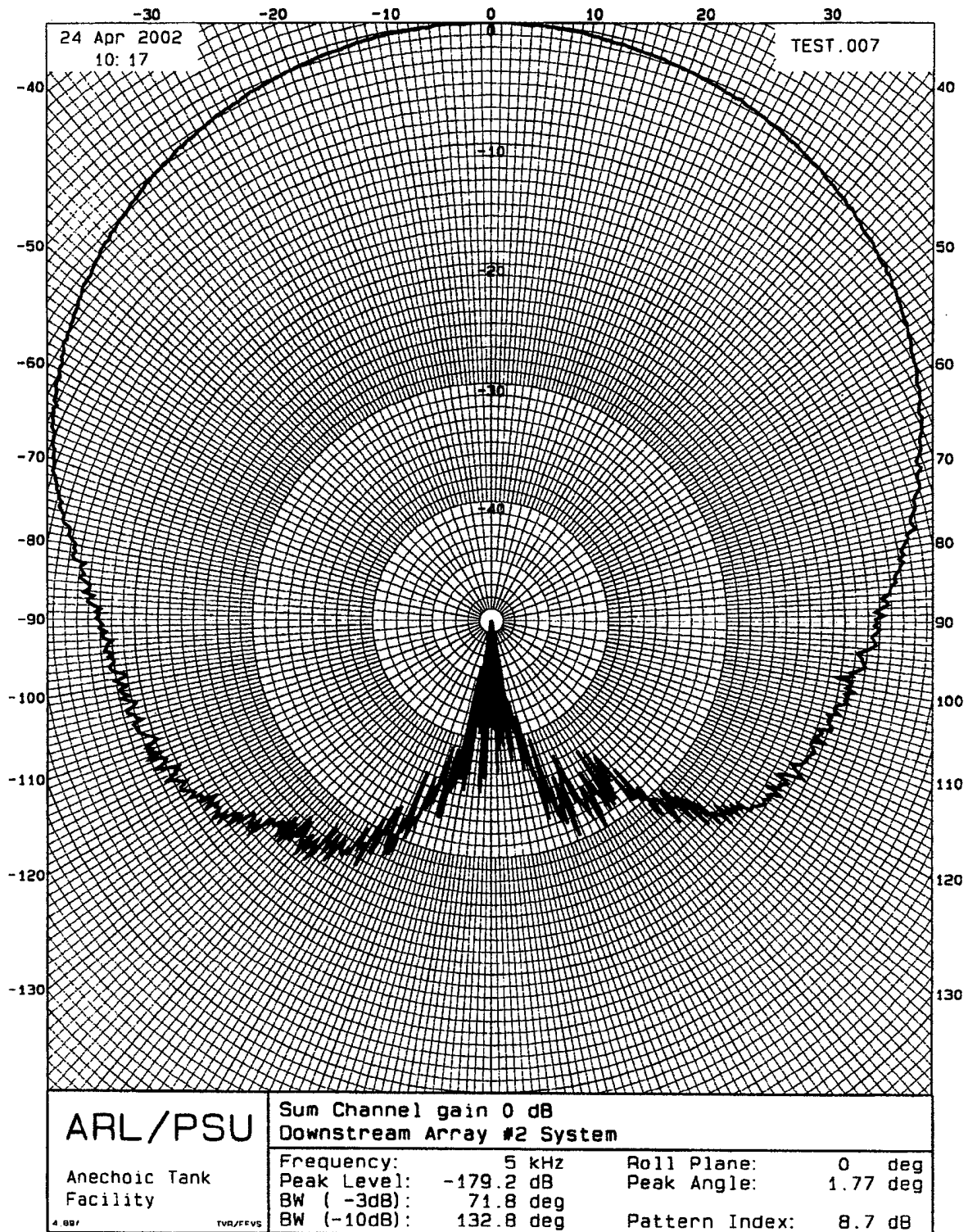

Figure 4-8. Measured Directivity Pattern, Sum Channel, 5 kHz, 0° Roll Angle

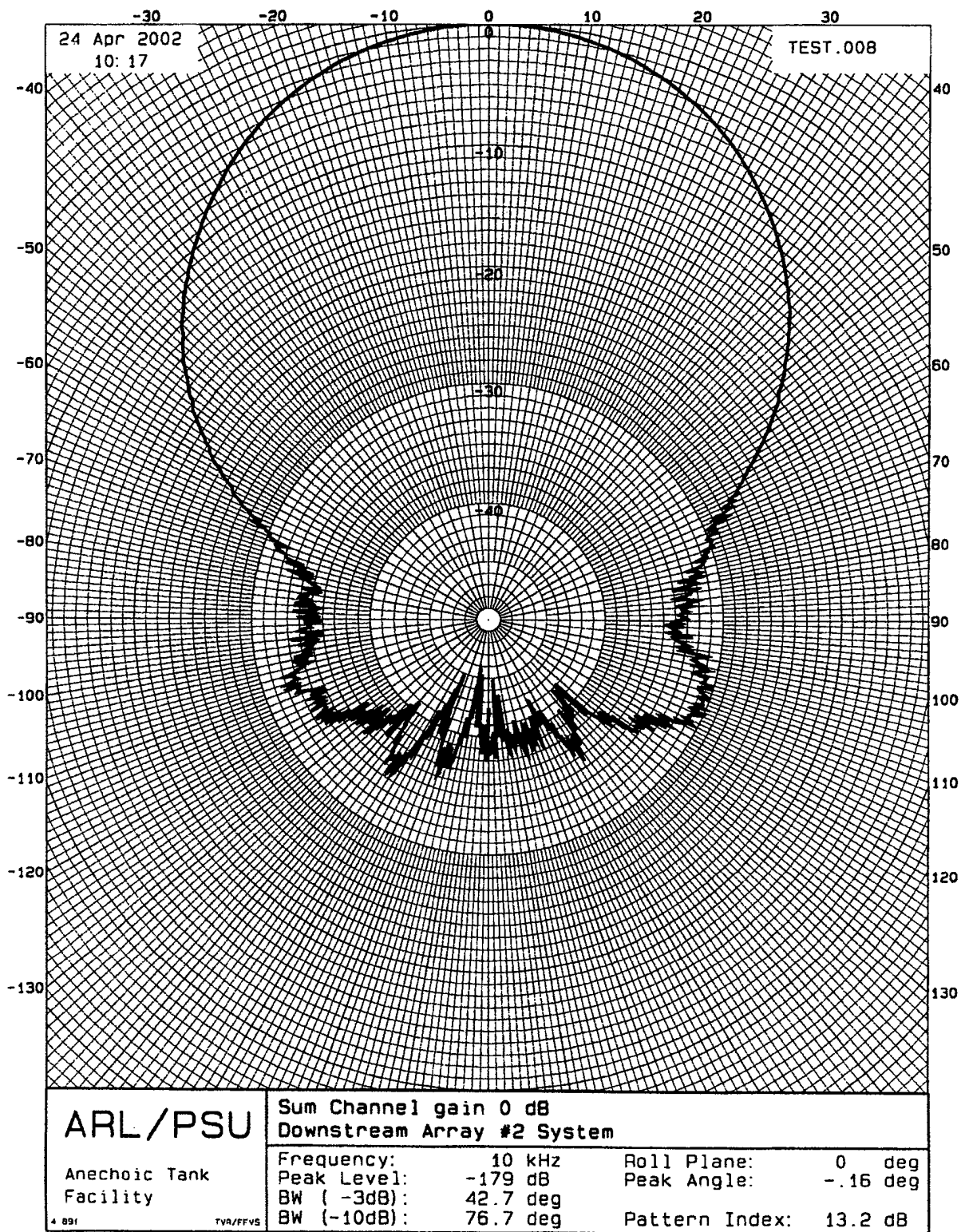

Figure 4-9. Measured Directivity Pattern, Sum Channel, 10 kHz, 0° Roll Angle

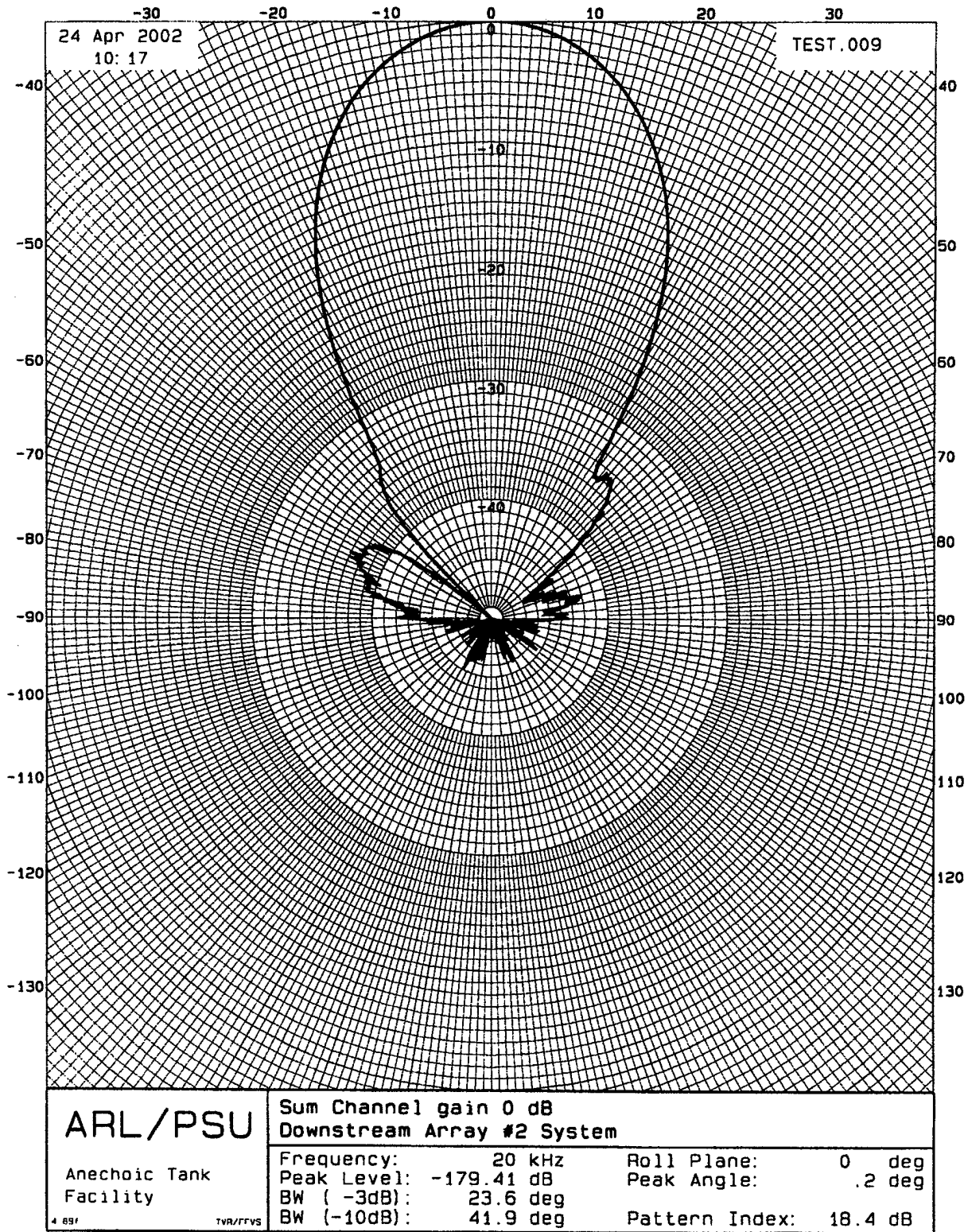
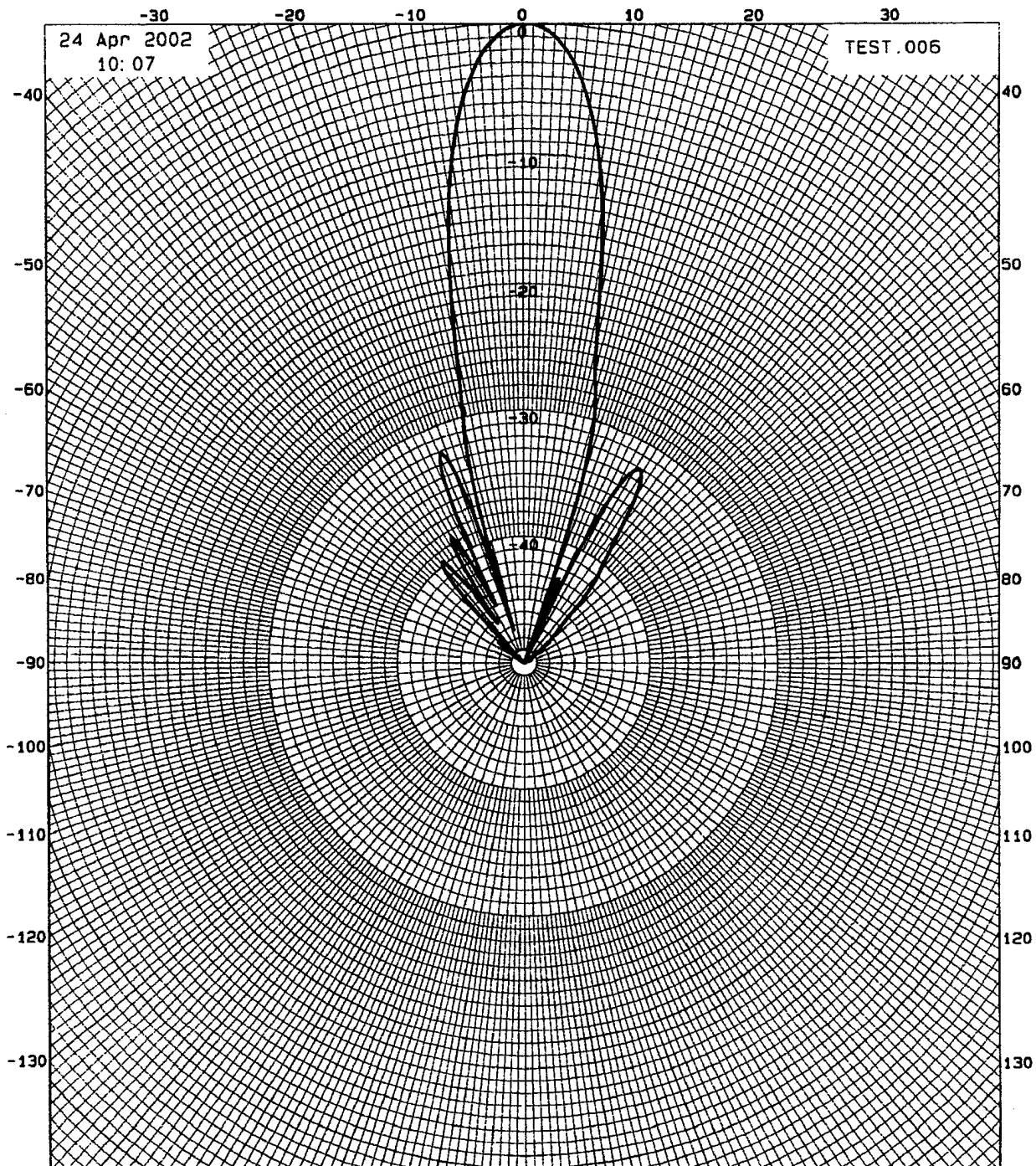

Figure 4-10. Measured Directivity Pattern, Sum Channel, 20 kHz, 0° Roll Angle



ARL/PSU Anechoic Tank Facility	Sum Channel gain 0 dB Downstream Array #2 System		
	Frequency: 50 kHz Peak Level: 161.11 dB BW (-3dB): 9.53 deg BW (-10dB): 16.8 deg	Roll Plane: 0 deg Peak Angle: .37 deg Pattern Index: 26.2 dB	

Figure 4-11. Measured Directivity Pattern, Sum Channel, 50 kHz, 0° Roll Angle

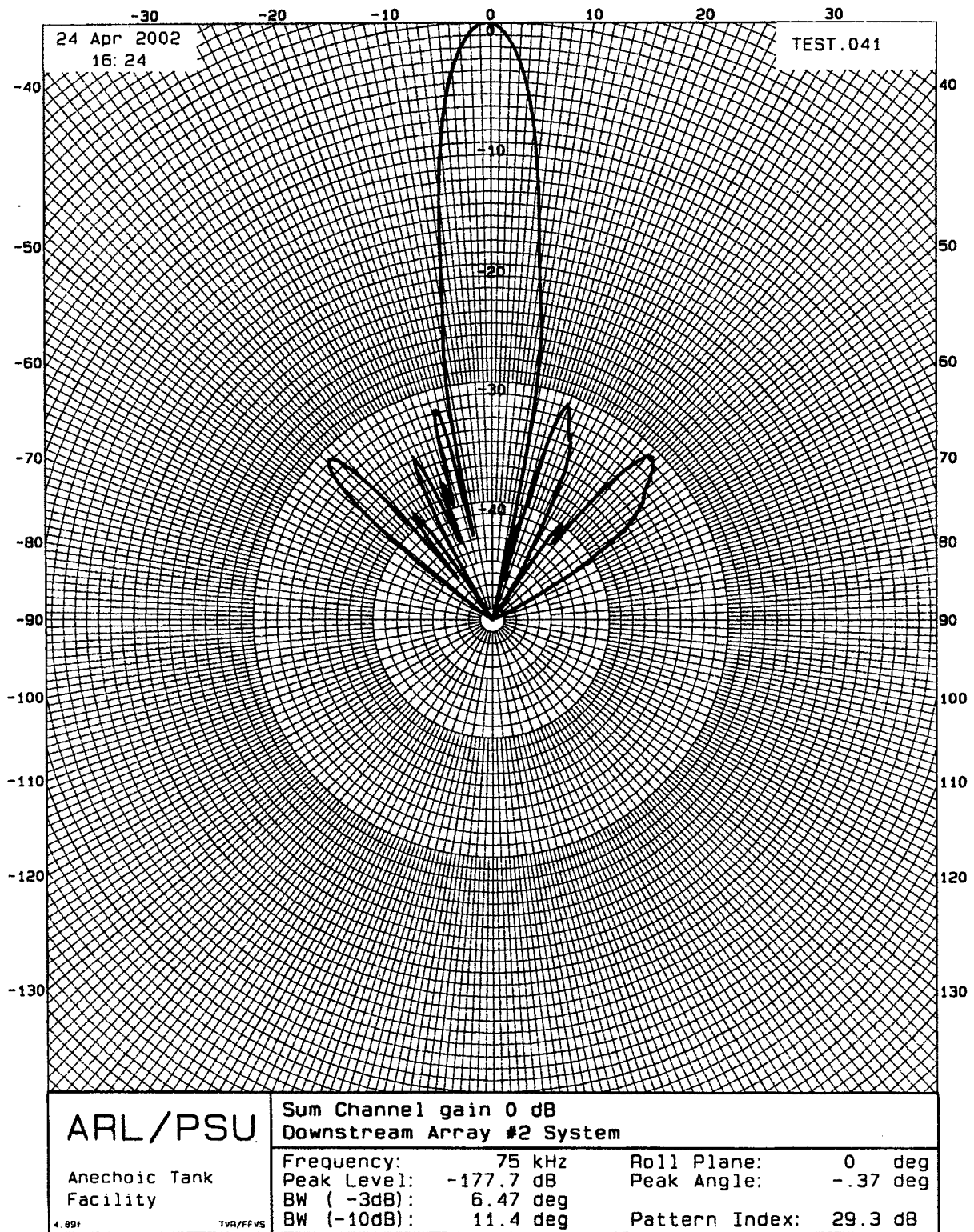

Figure 4-12. Measured Directivity Pattern, Sum Channel, 75 kHz, 0° Roll Angle

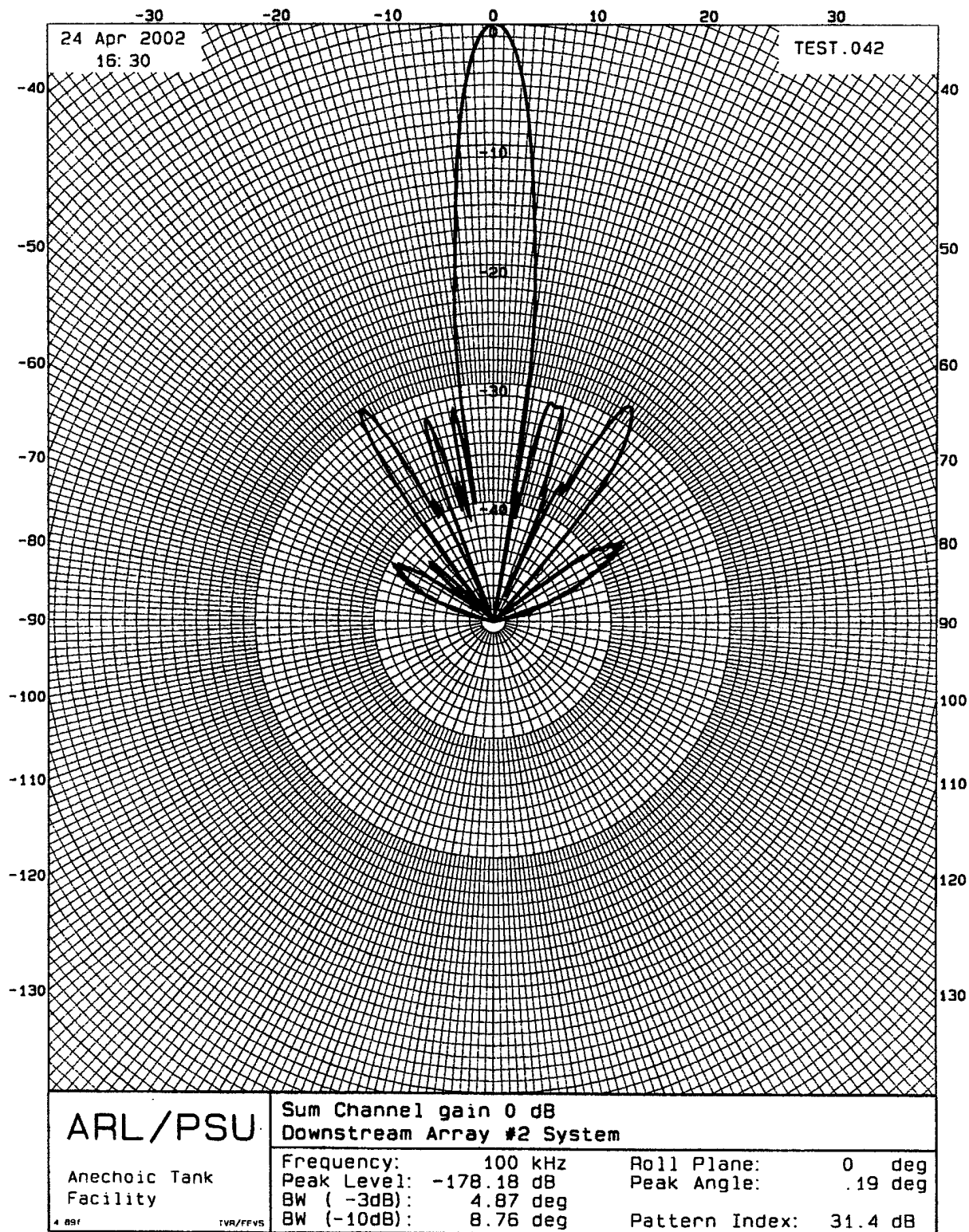

Figure 4-13. Measured Directivity Pattern, Sum Channel, 100 kHz, 0° Roll Angle

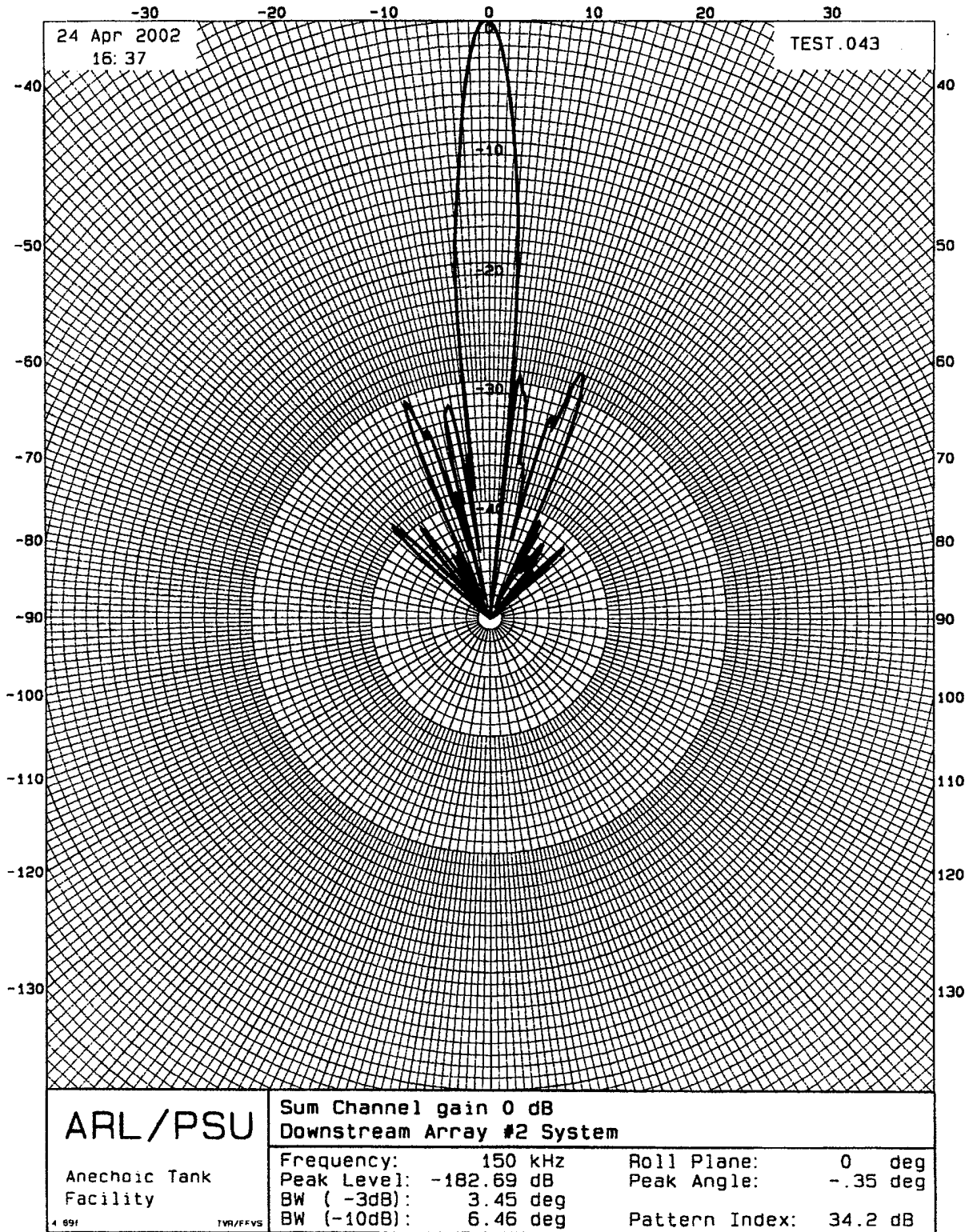

Figure 4-14. Measured Directivity Pattern, Sum Channel, 150 kHz, 0° Roll Angle

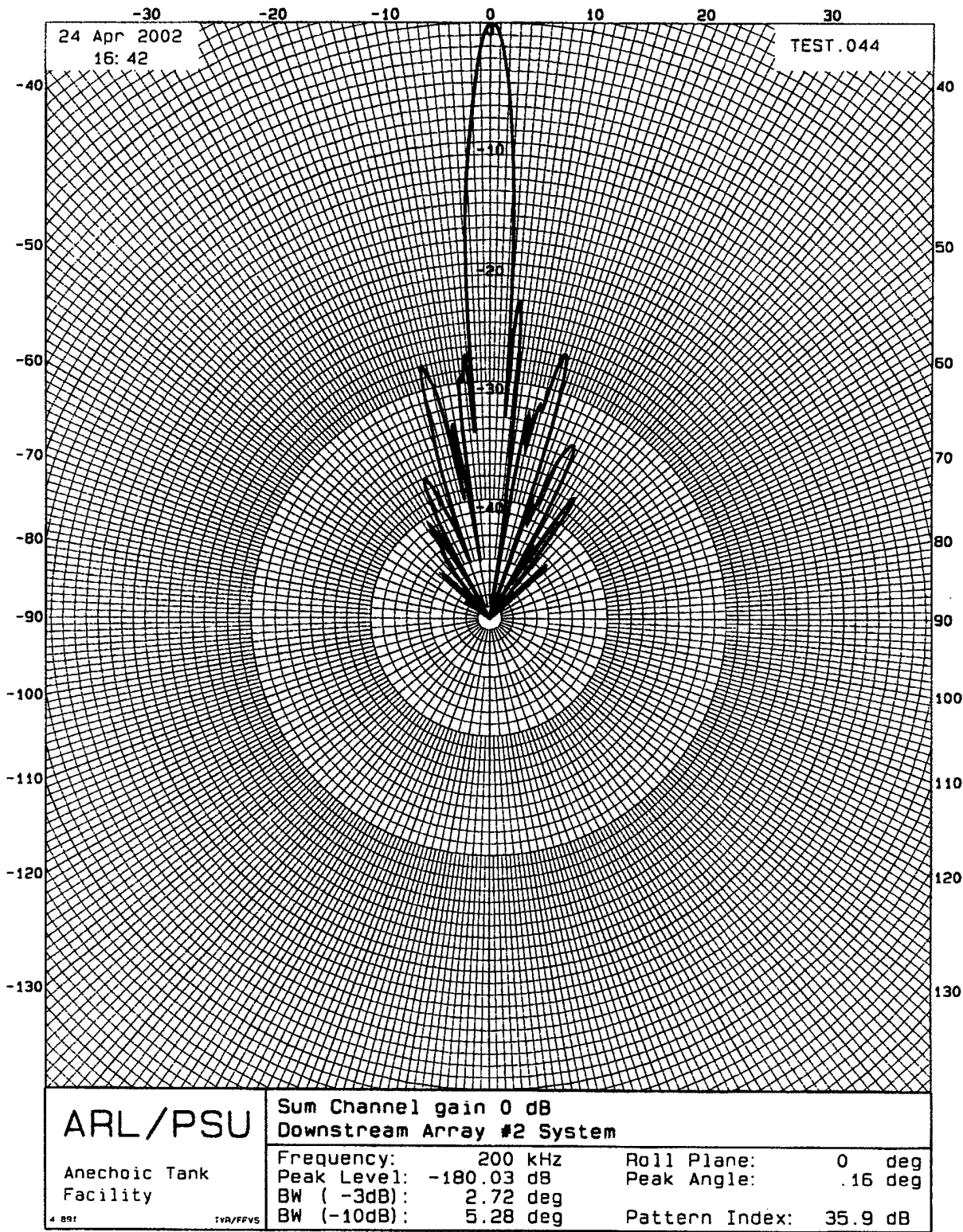

Figure 4-15. Measured Directivity Pattern, Sum Channel, 200 kHz, 0° Roll Angle

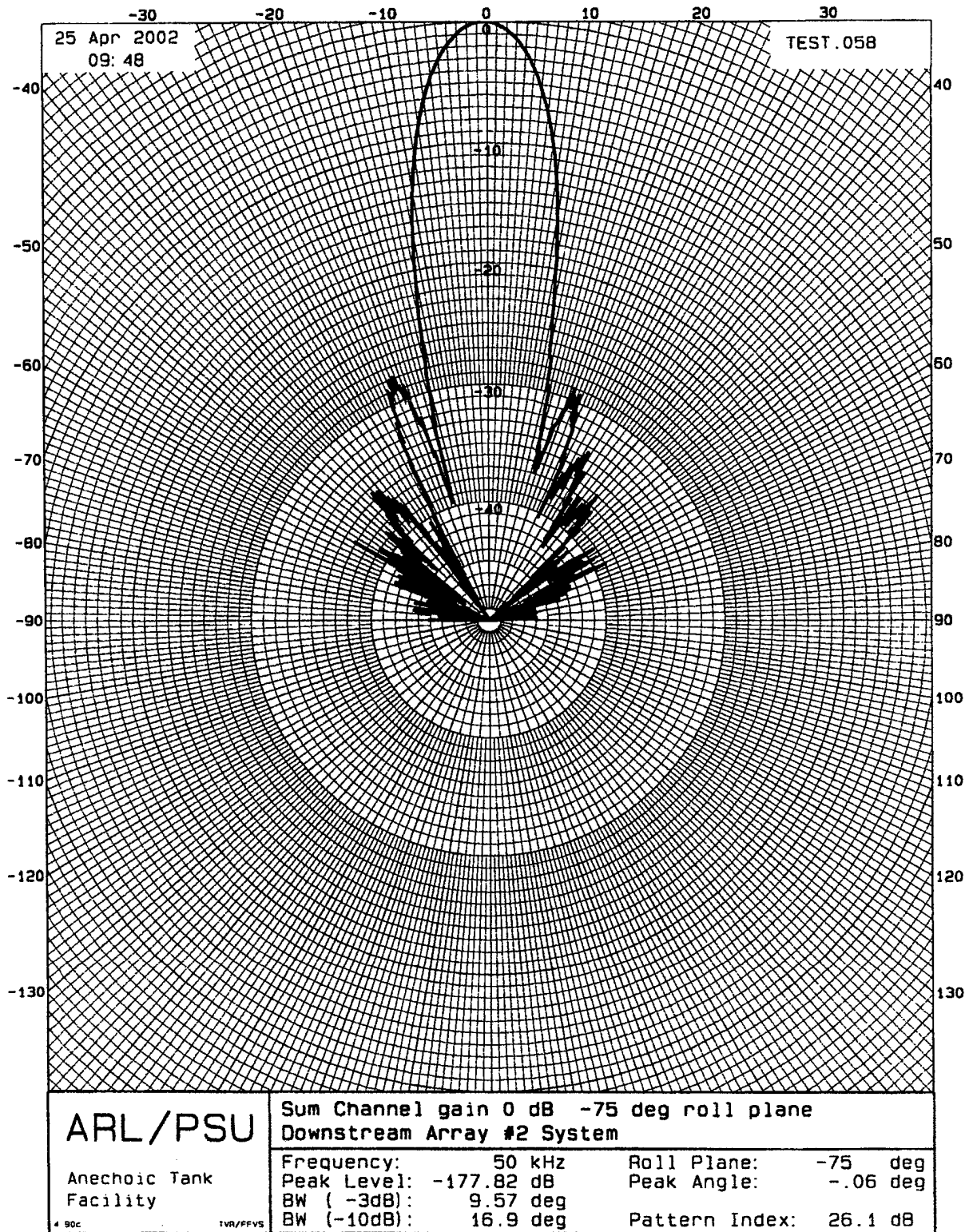

Figure 4-16. Measured Directivity Pattern, Sum Channel 50 kHz, -75° Roll Angle

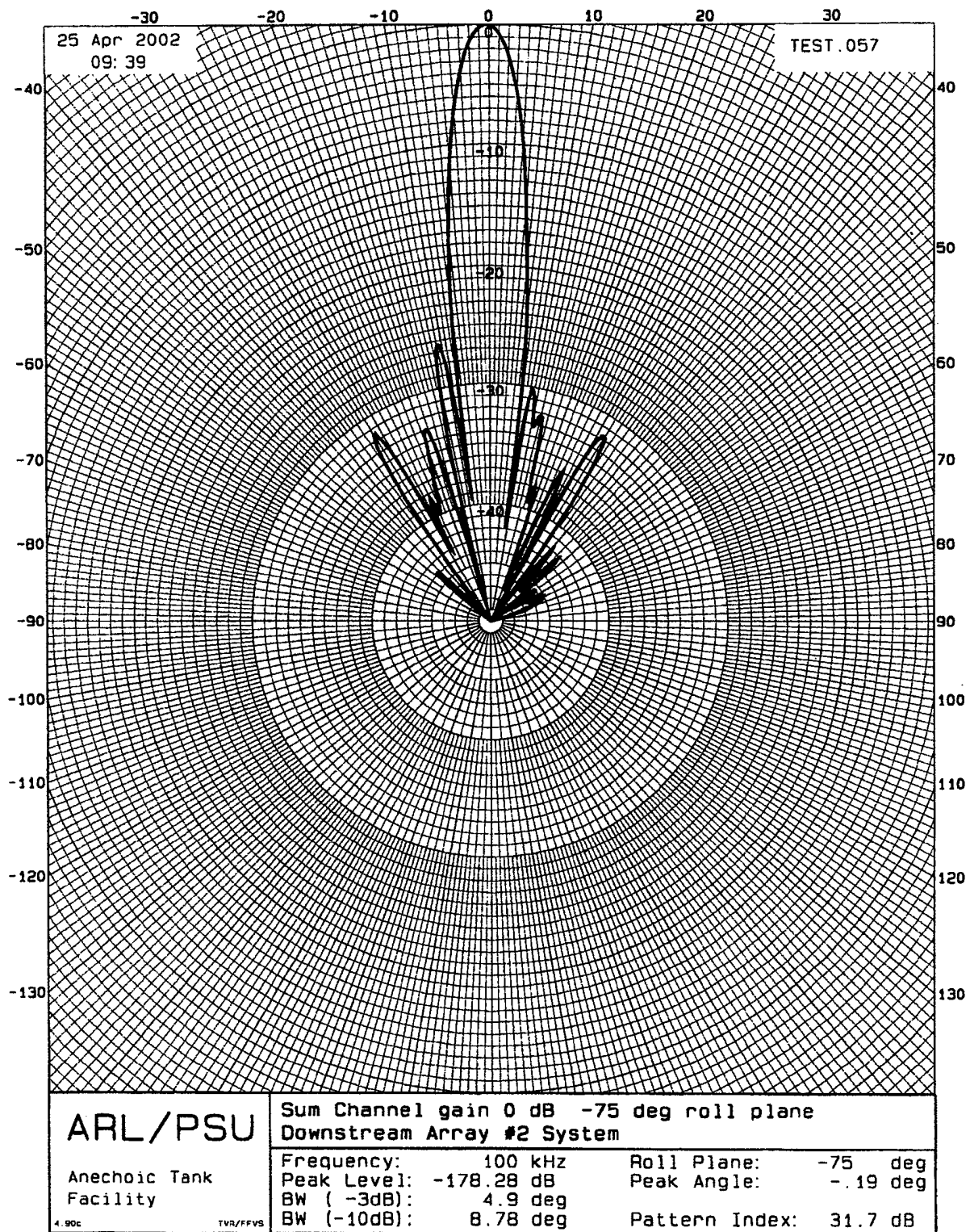

Figure 4-17. Measured Directivity Pattern, Sum Channel, 100 kHz, -75° Roll Angle

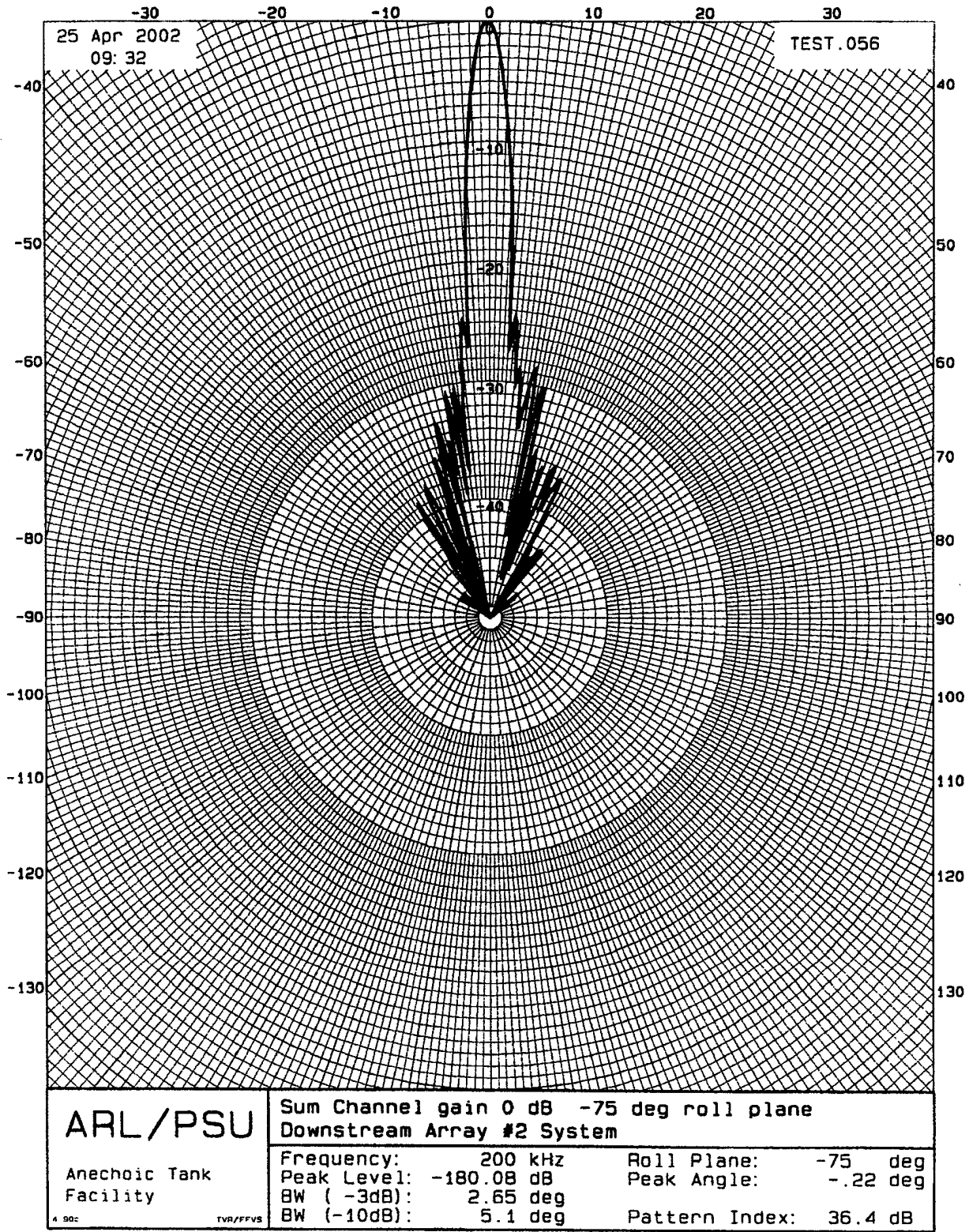

Figure 4-18. Measured Directivity Pattern, Sum Channel, 200 kHz, -75° Roll Angle

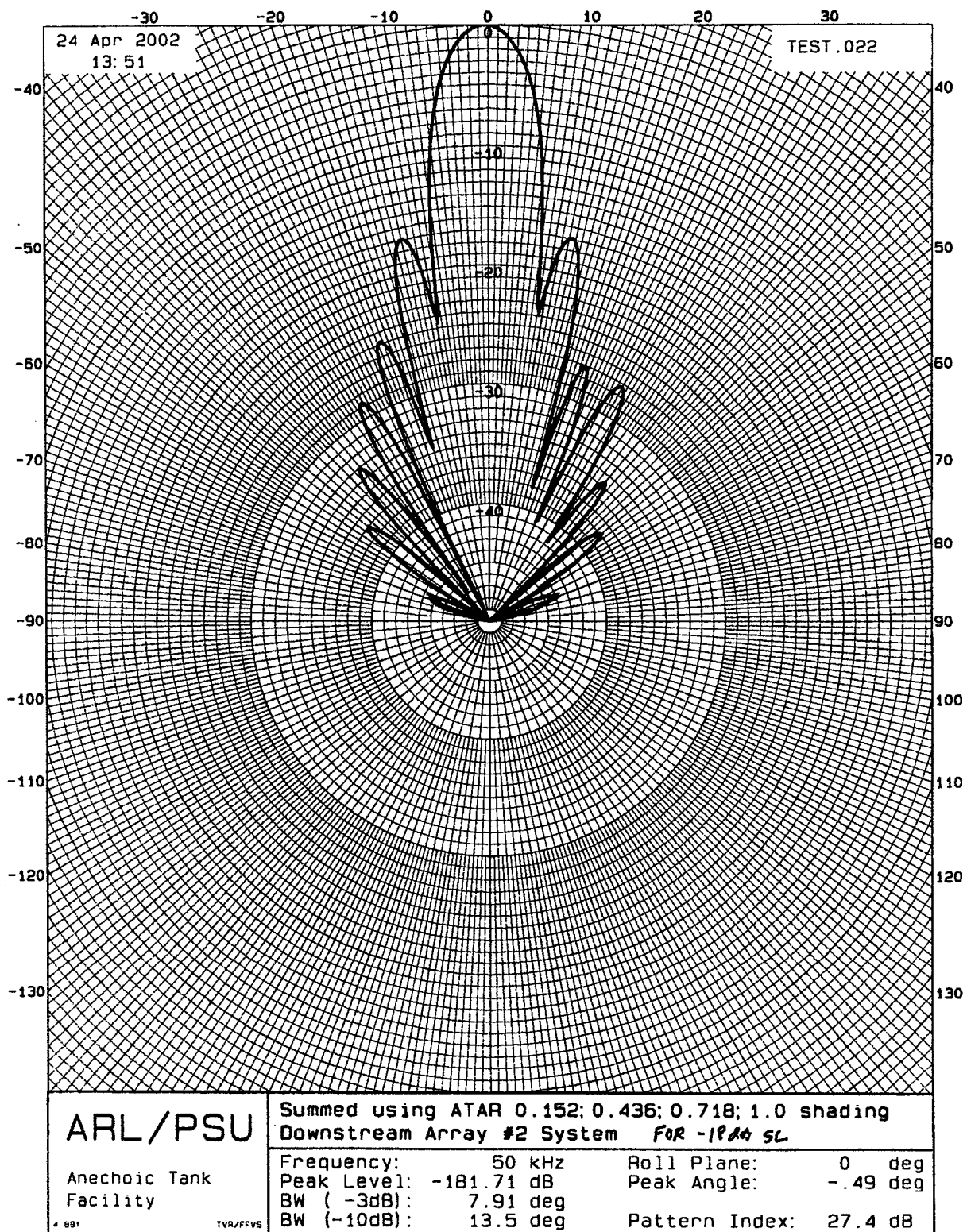

Figure 4-19. Measured Directivity Pattern, Channels 1 Through 4 Summed on ATAR System (Area Corrected Only), 50 kHz, 0° Roll Angle

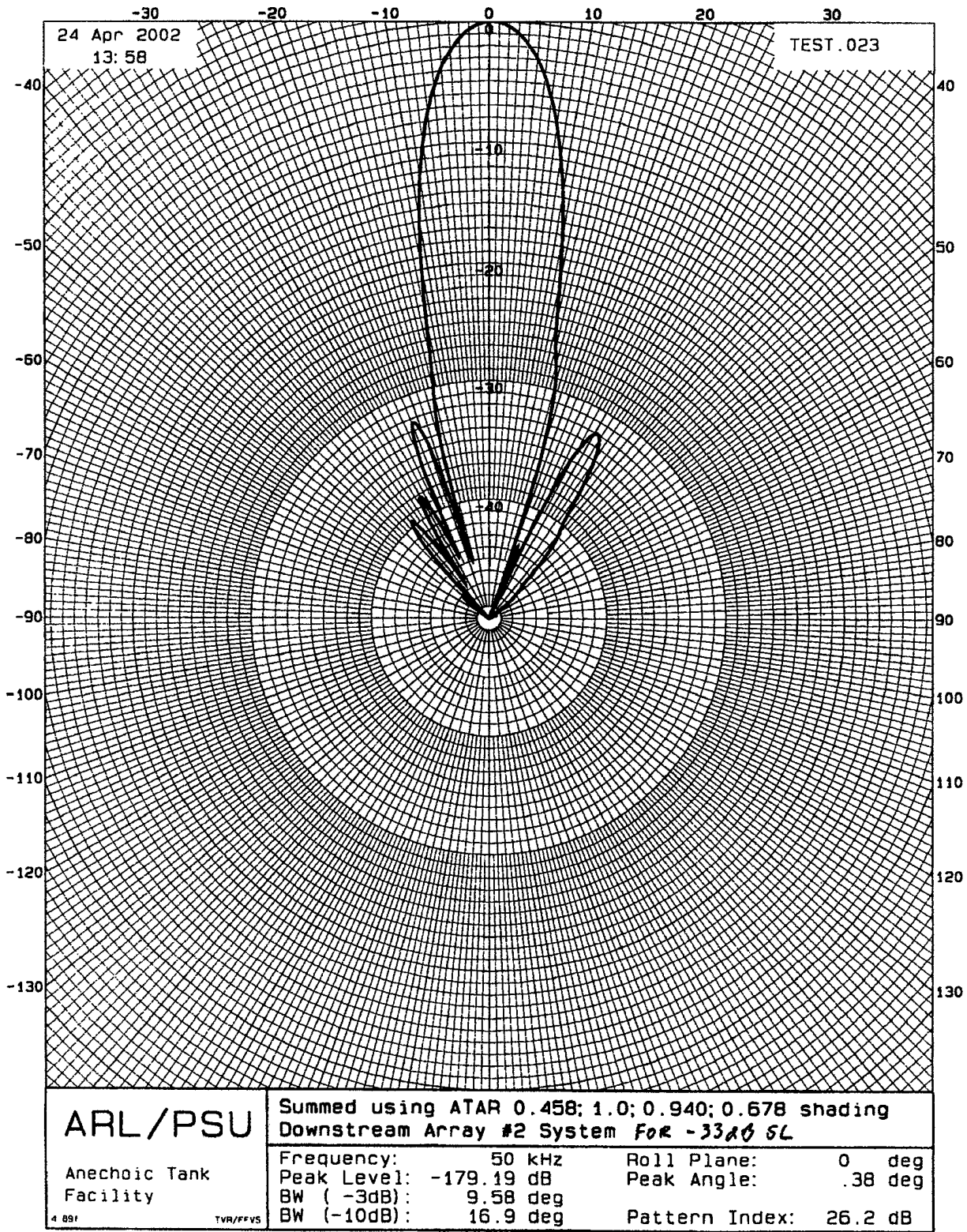

Figure 4-20. Measured Directivity Pattern, Channels 1 Through 4 Summed on ATAR System (Full Weighting), 50 kHz, 0° Roll Angle

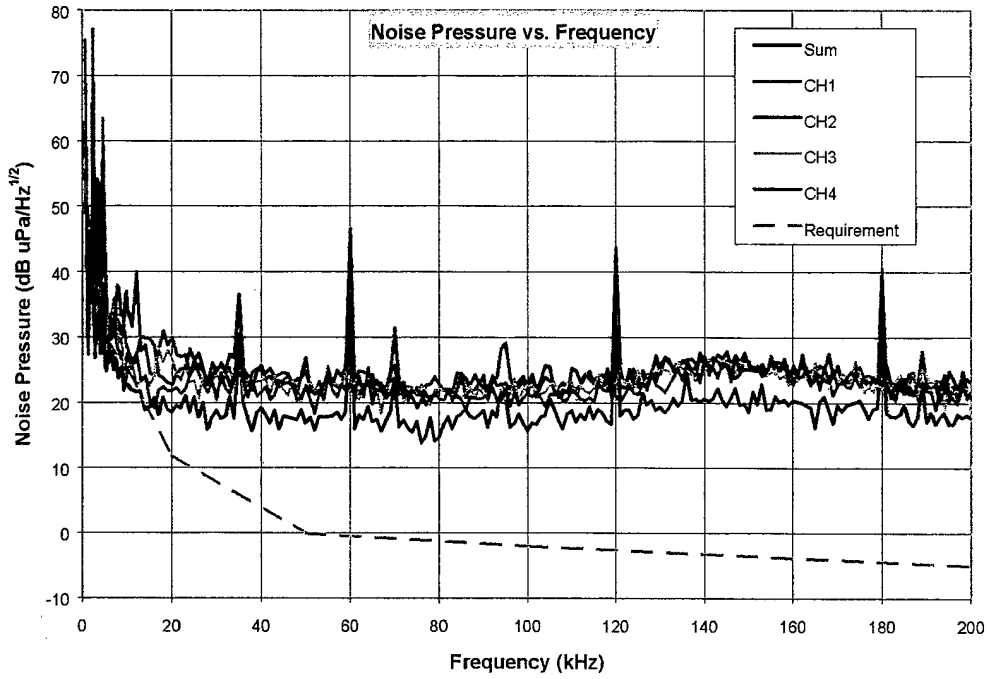

Figure 4-21. Noise for All Channels, 0 to 200 kHz

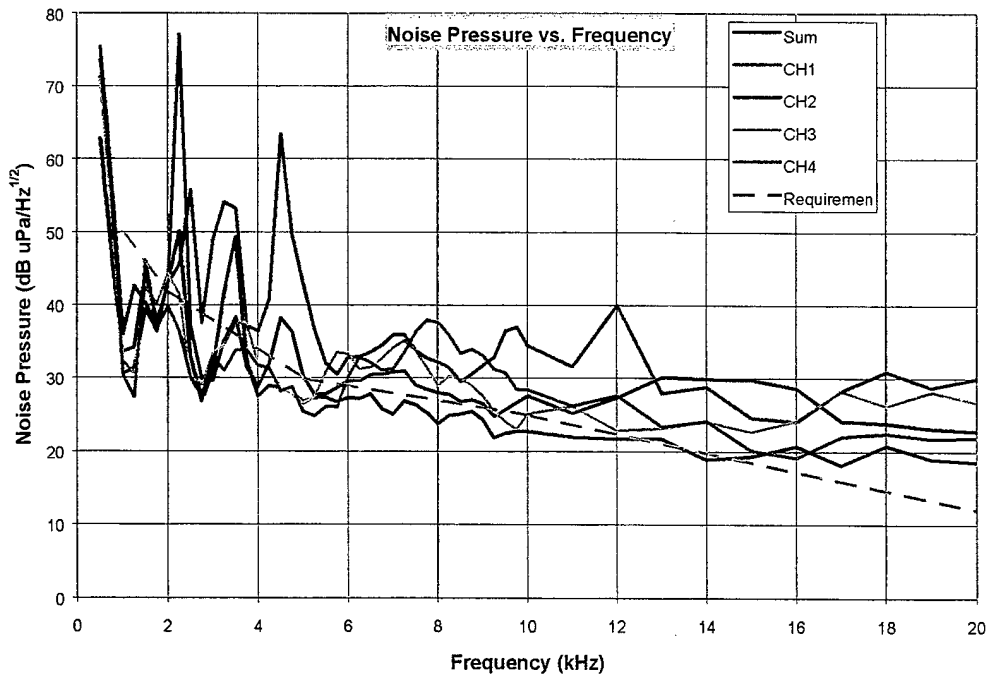

Figure 4-22. Noise for All Channels, 0 to 20 kHz

Appendix I. List of Test Data Files

Filename	Meas_Type	Frequency_Range	Test_Title	Measurement_Title
TEST.001	FFVS	5kHz to 50kHz	Downstream Array #2 System	Sum Channel gain 0 dB
TEST.002	FFVS	5kHz to 50kHz	Downstream Array #2 System	Channel #1 gain 0 dB
TEST.003	FFVS	5kHz to 50kHz	Downstream Array #2 System	Channel #2 gain 0 dB
TEST.004	FFVS	5kHz to 50kHz	Downstream Array #2 System	Channel #3 gain 0 dB
TEST.005	FFVS	5kHz to 50kHz	Downstream Array #2 System	Channel #4 gain 0 dB
TEST.006	BeamPatt	Pattern at 50 kHz	Downstream Array #2 System	Sum Channel gain 0 dB
TEST.007	BeamPatt	Pattern at 5 kHz	Downstream Array #2 System	Sum Channel gain 0 dB
TEST.008	BeamPatt	Pattern at 10 kHz	Downstream Array #2 System	Sum Channel gain 0 dB
3 TEST.009	BeamPatt	Pattern at 20 kHz	Downstream Array #2 System	Sum Channel gain 0 dB
TEST.010	FFVS	5kHz to 50kHz	Downstream Array #2 System	Sum Channel gain 40 dB
TEST.011	FFVS	5kHz to 50kHz	Downstream Array #2 System	Channel #1 gain 40 dB
TEST.012	FFVS	5kHz to 50kHz	Downstream Array #2 System	Channel #2 gain 40 dB
TEST.013	FFVS	5kHz to 50kHz	Downstream Array #2 System	Channel #3 gain 40 dB
TEST.014	FFVS	5kHz to 50kHz	Downstream Array #2 System	Channel #4 gain 40 dB
TEST.015	FFVS	5kHz to 50kHz	Downstream Array #2 System	Sum Channel gain 60 dB
TEST.016	FFVS	5kHz to 50kHz	Downstream Array #2 System	Channel #1 gain 60 dB
TEST.017	FFVS	5kHz to 50kHz	Downstream Array #2 System	Channel #2 gain 60 dB
TEST.018	FFVS	5kHz to 50kHz	Downstream Array #2 System	Channel #3 gain 60 dB
TEST.019	FFVS	5kHz to 50kHz	Downstream Array #2 System	Channel #4 gain 60 dB

Filename	Meas_Type	Frequency_Range	Test_Title	Measurement_Title
TEST.020	FFVS	5kHz to 50kHz	Downstream Array #2 System	Summed using ATAR panel (unshaded)
TEST.021	BeamPatt	Pattern at 50 kHz	Downstream Array #2 System	Summed using ATAR panel (unshaded)
TEST.022	BeamPatt	Pattern at 50 kHz	Downstream Array #2 System	Summed using ATAR 0.152;0.436;0.718;1.0 shading
TEST.023	BeamPatt	Pattern at 50 kHz	Downstream Array #2 System	Summed using ATAR 0.458;1.0;0.940;0.678 shading
TEST.024	FFVS	5kHz to 50kHz	Downstream Array #2 System	Summed using ATAR 0.458;1.0;0.940;0.678 shading
TEST.025	FFVS	5kHz to 50kHz	Downstream Array #2 System	Summed using ATAR 0.152;0.436;0.718;1.0 shading
TEST.026	FFVS	50kHz to 200kHz	Downstream Array #2 System	Sum Channel gain 0 dB
TEST.027	FFVS	50kHz to 200kHz	Downstream Array #2 System	Channel #1 gain 0 dB
TEST.028	FFVS	50kHz to 200kHz	Downstream Array #2 System	Channel #2 gain 0 dB
TEST.029	FFVS	50kHz to 200kHz	Downstream Array #2 System	Channel #3 gain 0 dB
TEST.030	FFVS	50kHz to 200kHz	Downstream Array #2 System	Channel #4 gain 0 dB
TEST.035	FFVS	50kHz to 200kHz	Downstream Array #2 System	Sum Channel gain 40 dB
TEST.031	FFVS	50kHz to 200kHz	Downstream Array #2 System	Channel #1 gain 40 dB
TEST.032	FFVS	50kHz to 200kHz	Downstream Array #2 System	Channel #2 gain 40 dB
TEST.033	FFVS	50kHz to 200kHz	Downstream Array #2 System	Channel #3 gain 40 dB
TEST.034	FFVS	50kHz to 200kHz	Downstream Array #2 System	Channel #4 gain 40 dB
TEST.036	FFVS	50kHz to 200kHz	Downstream Array #2 System	Sum Channel gain 60 dB
TEST.037	FFVS	50kHz to 200kHz	Downstream Array #2 System	Channel #1 gain 60 dB
TEST.038	FFVS	50kHz to 200kHz	Downstream Array #2 System	Channel #2 gain 60 dB
TEST.039	FFVS	50kHz to 200kHz	Downstream Array #2 System	Channel #3 gain 60 dB
TEST.040	FFVS	50kHz to 200kHz	Downstream Array #2 System	Channel #4 gain 60 dB

Filename	Meas_Type	Frequency_Range	Test_Title	Measurement_Title
TEST.041	BeamPatt	Pattern at 75 kHz	Downstream Array #2 System	Sum Channel gain 0 dB
TEST.042	BeamPatt	Pattern at 100 kHz	Downstream Array #2 System	Sum Channel gain 0 dB
TEST.043	BeamPatt	Pattern at 150 kHz	Downstream Array #2 System	Sum Channel gain 0 dB
TEST.044	BeamPatt	Pattern at 200 kHz	Downstream Array #2 System	Sum Channel gain 0 dB
TEST.055	FFVS	50kHz to 200kHz	Downstream Array #2 System	Sum Channel gain 60 dB
TEST.045	FFVS	50kHz to 200kHz	Downstream Array #2 System	Sum Channel gain 66 dB 75 deg roll plane
TEST.046	FFVS	50kHz to 200kHz	Downstream Array #2 System	Sum Channel gain 72 dB 75 deg roll plane
TEST.047	FFVS	50kHz to 200kHz	Downstream Array #2 System	Channel #1 gain 66 dB 75 deg roll plane
TEST.048	FFVS	50kHz to 200kHz	Downstream Array #2 System	Channel #2 gain 66 dB 75 deg roll plane
TEST.049	FFVS	50kHz to 200kHz	Downstream Array #2 System	Channel #3 gain 66 dB 75 deg roll plane
TEST.050	FFVS	50kHz to 200kHz	Downstream Array #2 System	Channel #4 gain 66 dB 75 deg roll plane
TEST.051	FFVS	50kHz to 200kHz	Downstream Array #2 System	Channel #1 gain 72 dB 75 deg roll plane
TEST.052	FFVS	50kHz to 200kHz	Downstream Array #2 System	Channel #2 gain 72 dB 75 deg roll plane
TEST.053	FFVS	50kHz to 200kHz	Downstream Array #2 System	Channel #3 gain 72 dB 75 deg roll plane
TEST.054	FFVS	50kHz to 200kHz	Downstream Array #2 System	Channel #4 gain 72 dB 75 deg roll plane
TEST.056	BeamPatt	Pattern at 200 kHz	Downstream Array #2 System	Sum Channel gain 0 dB 75 deg roll plane
TEST.057	BeamPatt	Pattern at 100 kHz	Downstream Array #2 System	Sum Channel gain 0 dB 75 deg roll plane
TEST.058	BeamPatt	Pattern at 50 kHz	Downstream Array #2 System	Sum Channel gain 0 dB 75 deg roll plane
TEST.060	FFVS	.5kHz to 10kHz	Downstream Array #2 System	Channel #1 gain 32 dB 75 deg roll plane
TEST.061	FFVS	.5kHz to 10kHz	Downstream Array #2 System	Channel #2 gain 32 dB 75 deg roll plane
TEST.062	FFVS	.5kHz to 10kHz	Downstream Array #2 System	Channel #3 gain 32 dB 75 deg roll plane

Filename	Meas_Type	Frequency_Range	Test_Title	Measurement_Title
TEST.063	FFVS	.5kHz to 10kHz	Downstream Array #2 System	Channel #4 gain 32 dB - 75 deg roll plane
TEST.064	BeamPatt	Pattern at 1 kHz	Downstream Array #2 System	Sum Channel gain 32 dB - 75 deg roll plane
TEST.065	FFVS	.5kHz to 10kHz	Downstream Array #2 System	Sum Channel gain 20 dB - 75 deg roll Long pulse
TEST.066	FFVS	.5kHz to 10kHz	Downstream Array #2 System	Channel #1 gain 32 dB - 75 deg roll Long pulse
TEST.067	FFVS	.5kHz to 10kHz	Downstream Array #2 System	Channel #2 gain 32 dB - 75 deg roll Long pulse
TEST.068	FFVS	.5kHz to 10kHz	Downstream Array #2 System	Channel #3 gain 32 dB - 75 deg roll Long pulse
TEST.069	FFVS	.5kHz to 10kHz	Downstream Array #2 System	Channel #4 gain 32 dB - 75 deg roll Long pulse

Distribution List for Unclassified ARL Penn State TM 02-080, entitled "Water Tunnel Downstream Array (ARL No. 02-16) Design and Test Report", by C. W. Allen, E. C. Myer and B. L. Kline, dated 27 October 2003.

Office of Naval Research
Ballston Centre Tower One
800 North Quincy Street
Arlington, VA 22217-5660

Attn: Dr. Patrick Purtell, ONR 333
Copy No. 1

Dr. Steven Schreppler, ONR 334
Copy No. 2

Ms. Lynn Peterson, ONR
Copy No. 3

Naval Sea Systems Command
614 Sicard Street SE
Washington Navy Yard, DC 20376

Attn: Mr. Joseph Meijide, 073R
Copy No. 4

Ms. Margaret Stout, 073R
Copy No. 5

Mr. James Kearney, 08
Copy No. 6

Naval Surface Warfare Center
9500 Naval Surface Warfare Center
Carderock Division
MacArthur Boulevard
West Bethesda, MD 20817

Attn: Mr. Jude Brown, 508
Copy No. 7

Knolls Atomic Power Lab
P.O. Box 1072
Schenectady, NY 12301-1072

Attn: Dr. Martin Pollack
Copy No. 8

Electric Boat Corporation
75 Eastern Point Road
Groton, CT 06340

Attn: Mr. Glenn Clark
Copy No. 9

Office of Naval Research Regional Office
Chicago
536 South Clark Street, Room 208
Chicago, IL 60605-1588
Copy No. 10

Defense Technical Information Center
8725 John J. Kingman Road, Suite 0944
Fort Belvoir, VA 22060-6218
Copy No. 11

Naval Research Laboratory
4555 Overlook Avenue SW
Washington, DC 20375-5320

Attn: Code 5227
Copy No. 12

Applied Research Laboratory
P.O. Box 30
State College, PA 16801

Attn: R. C. Marboe
Copy No. 13

A. A. Fontaine
Copy No. 14

T. Cawley
Copy No. 15

M. L. Billet
Copy No. 16

D. E. Capone
Copy No. 17

W. C. Zierke
Copy No. 18

R. E. Masters
Copy No. 19

M. J. Pierzga
Copy No. 20

C. W. Allen
Copy No. 21

E. C. Myer
Copy No. 22

B. L. Kline
Copy No. 23

SED Files
Copy No. 24
WT Files
Copy No. 25

ARL Library
Copy No. 26