



NAVAL
POSTGRADUATE
SCHOOL

MONTEREY, CALIFORNIA

THESIS

**LEAST SQUARES AND ADAPTIVE MULTIRATE
FILTERING**

by

Anthony H. Hawes

September 2003

Thesis Advisor:
Second Reader:

Charles W. Therrien
Roberto Cristi

Approved for public release; distribution is unlimited

THIS PAGE INTENTIONALLY LEFT BLANK

REPORT DOCUMENTATION PAGE			<i>Form Approved OMB No. 0704-0188</i>
Public reporting burden for this collection of information is estimated to average 1 hour per response, including the time for reviewing instruction, searching existing data sources, gathering and maintaining the data needed, and completing and reviewing the collection of information. Send comments regarding this burden estimate or any other aspect of this collection of information, including suggestions for reducing this burden, to Washington headquarters Services, Directorate for Information Operations and Reports, 1215 Jefferson Davis Highway, Suite 1204, Arlington, VA 22202-4302, and to the Office of Management and Budget, Paperwork Reduction Project (0704-0188) Washington DC 20503.			
1. AGENCY USE ONLY (Leave blank)	2. REPORT DATE September 2003	3. REPORT TYPE AND DATES COVERED Master's Thesis	
4. TITLE AND SUBTITLE: Least Squares and Adaptive Multirate Filtering			5. FUNDING NUMBERS
6. AUTHOR(S) Anthony H. Hawes			
7. PERFORMING ORGANIZATION NAME(S) AND ADDRESS(ES) Naval Postgraduate School Monterey, CA 93943-5000			8. PERFORMING ORGANIZATION REPORT NUMBER
9. SPONSORING /MONITORING AGENCY NAME(S) AND ADDRESS(ES) N/A			10. SPONSORING/MONITORING AGENCY REPORT NUMBER
11. SUPPLEMENTARY NOTES The views expressed in this thesis are those of the author and do not reflect the official policy or position of the Department of Defense or the U.S. Government.			
12a. DISTRIBUTION / AVAILABILITY STATEMENT Approved for public release; distribution is unlimited			12b. DISTRIBUTION CODE
13. ABSTRACT (maximum 200 words) This thesis addresses the problem of estimating a random process from two observed signals sampled at different rates. The case where the low-rate observation has a higher signal-to-noise ratio than the high-rate observation is addressed. Both adaptive and non-adaptive filtering techniques are explored. For the non-adaptive case, a multirate version of the Wiener-Hopf optimal filter is used for estimation. Three forms of the filter are described. It is shown that using both observations with this filter achieves a lower mean-squared error than using either sequence alone. Furthermore, the amount of training data to solve for the filter weights is comparable to that needed when using either sequence alone. For the adaptive case, a multirate version of the LMS adaptive algorithm is developed. Both narrowband and broadband interference are removed using the algorithm in an adaptive noise cancellation scheme. The ability to remove interference at the high rate using observations taken at the low rate without the high-rate observations is demonstrated.			
14. SUBJECT TERMS Multirate filtering, Adaptive filtering, Multirate Adaptive Filter, Multirate Optimal Filter, Least squares Filtering			15. NUMBER OF PAGES 65
			16. PRICE CODE
17. SECURITY CLASSIFICATION OF REPORT Unclassified	18. SECURITY CLASSIFICATION OF THIS PAGE Unclassified	19. SECURITY CLASSIFICATION OF ABSTRACT Unclassified	20. LIMITATION OF ABSTRACT UL

THIS PAGE INTENTIONALLY LEFT BLANK

Approved for public release; distribution is unlimited

LEAST SQUARES AND ADAPTIVE MULTIRATE FILTERING

Anthony H. Hawes
Lieutenant, United States Coast Guard
B.S., United States Coast Guard Academy, 1999

Submitted in partial fulfillment of the
requirements for the degree of

MASTER OF SCIENCE IN ELECTRICAL ENGINEERING

from the

**NAVAL POSTGRADUATE SCHOOL
September 2003**

Author: Anthony H. Hawes

Approved by: Charles W. Therrien
Thesis Advisor

Roberto Cristi
Second Reader

John P. Powers
Chairman, Department of Electrical and Computer Engineering

THIS PAGE INTENTIONALLY LEFT BLANK

ABSTRACT

This thesis addresses the problem of estimating a random process from two observed signals sampled at different rates. The case where the low-rate observation has a higher signal-to-noise ratio than the high-rate observation is addressed. Both adaptive and non-adaptive filtering techniques are explored. For the non-adaptive case, a multirate version of the Wiener-Hopf optimal filter is used for estimation. Three forms of the filter are described. It is shown that using both observations with this filter achieves a lower mean-squared error than using either sequence alone. Furthermore, the amount of training data to solve for the filter weights is comparable to that needed when using either sequence alone. For the adaptive case, a multirate version of the LMS adaptive algorithm is developed. Both narrowband and broadband interference are removed using the algorithm in an adaptive noise cancellation scheme. The ability to remove interference at the high rate using observations taken at the low rate without the high-rate observations is demonstrated.

THIS PAGE INTENTIONALLY LEFT BLANK

TABLE OF CONTENTS

I.	INTRODUCTION.....	1
II.	THE MULTIRATE WIENER FILTER.....	3
A.	PROBLEM DESCRIPTION.....	3
B.	THREE FORMS OF THE FILTER	5
1.	Direct Form	5
a.	<i>Derivation of Estimate</i>	<i>7</i>
b.	<i>Least Squares Formulation</i>	<i>8</i>
2.	Innovations Form.....	9
3.	Interpolation Form	11
C.	COMPUTATIONAL REQUIREMENTS	11
D.	SIMULATION RESULTS	13
1.	Preliminaries	13
2.	Multirate vs. Single-rate Filter.....	13
3.	Required Training Data	15
a.	<i>Low-rate Filter Order $Q = 3$</i>	<i>15</i>
b.	<i>Low-rate Filter Order $Q = 10$.....</i>	<i>16</i>
4.	Optimizing Filter Tap Weights.....	17
III.	THE MULTIRATE LMS FILTER.....	21
A.	BACKGROUND	21
B.	FILTER DESCRIPTION.....	22
C.	SIMULATION PRELIMINARIES.....	25
D.	SIMULATION RESULTS	27
1.	Narrowband Interference	27
a.	<i>Using Both Observation Signals.....</i>	<i>28</i>
b.	<i>Using Low-Rate Observations Alone.....</i>	<i>28</i>
2.	Broadband Interference	29
IV.	CONCLUSIONS AND RECOMMENDATIONS.....	33
A.	CONCLUSIONS	33
1.	Optimal Filtering	33
2.	Adaptive Filtering	34
B.	RECOMMENDATIONS FOR FUTURE WORK.....	34
APPENDIX.....		37
A.	GENERATION OF OBSERVED SIGNALS	37
B.	GENERATION OF THE DESIRED SIGNALS.....	38
C.	CALCULATION OF THE SIGNAL-TO-NOISE RATIO.....	39
D.	CALCULATION OF ANTI-ALIASING FILTER COEFFICIENTS	40
LIST OF REFERENCES.....		45
INITIAL DISTRIBUTION LIST		47

THIS PAGE INTENTIONALLY LEFT BLANK

LIST OF FIGURES

Figure 1.	Thesis Outline Flow Diagram.....	2
Figure 2.	Overview of Estimation Process.....	3
Figure 3.	Direct Form of the Multirate Wiener Filter.....	5
Figure 4.	Internal Operation of Multirate Wiener Filter.....	6
Figure 5.	Innovations Form of Multirate Wiener Filter.....	10
Figure 6.	Interpolation Form of Multirate Wiener Filter.....	11
Figure 7.	Mean-Squared Error versus Data Length for $Q = 3$. TOP: Low-rate data alone. MIDDLE: High-rate data alone. BOTTOM: Both data sets.....	16
Figure 8.	Mean-Squared Error versus Data Length for $Q = 10$. TOP: Low-rate data alone. MIDDLE: High-rate data alone. BOTTOM: Both data sets.....	17
Figure 9.	Sample time-varying filters used in multirate Wiener filtering. (a) FM Signal: High-rate weights, (b) FM Signal: Low-rate weights. (c) AR Signal: High-rate weights, (d) AR Signal: Low-rate weights. (e) SINE signal: High-rate weights, (f) SINE signal: Low-rate weights.....	19
Figure 10.	Simplified Diagram of Multirate LMS Filter.....	22
Figure 11.	Detailed Diagram of Multirate LMS Algorithm.....	24
Figure 12.	Adaptive Interference Cancellation with Two Reference Inputs.....	26
Figure 13.	Plot of voice signal of the spoken word 'hello' used in narrowband interference simulation. (a) Original speech signal. (b) Speech signal including tones.....	27
Figure 14.	Signals after filtering. (a) Original speech signal. (b) Filtered signal using both data sequences with $K = 4$. (c) Filtered signal using low-rate data alone with $K = 4$	29
Figure 15.	Results for multirate LMS filtering using low-rate observations alone. (a) Original speech signal. (b) Signal plus interference. (c) Filtered signal. (d) Original interference signal. (e) Estimate of interference.....	31
Figure 16.	Diagram of data generation process for simulation of multirate Wiener-Hopf filtering.....	37
Figure 17.	Listing of Antialiasing Filter Coefficients (for $N = 172$ and $K = 3$).....	41
Figure 18.	Listing of Antialiasing Filter Coefficients (for $N = 570$ and $K = 10$).....	42

THIS PAGE INTENTIONALLY LEFT BLANK

LIST OF TABLES

Table 1.	List of Notation.....	4
Table 2.	Computational Requirements for the Three Forms of the Filter.....	12
Table 3.	Mean-Squared Error for $Q = 3$ (100 trial average).	14
Table 4.	Mean-Squared Error for $Q = 10$ (100 trial average).....	14
Table 5.	Listing of the Multirate LMS algorithm.	24

THIS PAGE INTENTIONALLY LEFT BLANK

ACKNOWLEDGMENTS

I would like to thank my mother, Veronica, whose support and guidance has always allowed me to achieve great things.

I wish to thank my thesis advisor, Professor Charles Therrien, for his guidance, patience and thoughtful comments, which were central to the completion of this thesis research. I would also like to thank Professor Roberto Cristi for his helpful comments on this report.

I also wish to thank Professors Monique Fargues, Arthur Schoenstadt, and Xiaoping Yun, whose lucid and thorough lectures helped me better understand the subject matter in this report.

THIS PAGE INTENTIONALLY LEFT BLANK

EXECUTIVE SUMMARY

This thesis addresses the problem of estimating a random process using two observation sequences; one sequence is sampled at a lower rate than that of the estimated process. This has potential military applications in the areas of satellite-based remote sensing, network-based sensor suites, and various other multirate signal and image processing applications.

Two new multirate filtering algorithms are described. The first multirate filtering algorithm is based on the Wiener-Hopf least squares optimal filtering equations. Results show that using both observation sequences with this filter provides a lower mean-squared error than when using a classic Wiener-Hopf filter with either the high-rate or low-rate observations alone. Additionally, the amount of training data needed to estimate the filter weights proved to be comparable to that needed when using either data sequence alone. The second multirate algorithm is adaptive and based on the least mean square (LMS) algorithm of Widrow and Hoff. Results are presented in terms of an adaptive noise cancellation scenario. The ability to remove both narrowband and broadband interference from a signal at the high rate using low-rate observations alone is demonstrated.

THIS PAGE INTENTIONALLY LEFT BLANK

I. INTRODUCTION

Multirate signal processing has become an important area of digital signal processing since there are few standards that govern the rate at which data is collected and sampled. Multirate signal processing is a rich field for research, encompassing everything from deterministic operations like sampling rate conversion to statistical treatments using multiple observations. Some applications include sampling rate conversion for oversampling subsystems for CD or DAT players [1], and subband coding of speech in digital communications systems [2]. Some statistical research involves wavelets for modulating signals to be transmitted over channels with unknown characteristics [3].

This thesis describes research which is part of an overall project to investigate methods of combining information taken from sensors with different sampling rates. Specifically, this thesis addresses the situation where an underlying continuous-time signal is measured by multiple sensors, each with a different sampling rate, and a different signal-to-noise ratio.

The basis for this research was established previously [4]. The purpose of this work was to 1) investigate and validate the previous theoretical work with simulation results; 2) extend the methods using a least squares approach, and 3) extend the methods to adaptive filtering.

The organization of this thesis is depicted in Figure 1. The thesis consists of four chapters and an appendix. Chapter I introduces the topic and provides a description of the filtering problem. Chapters II and III address related but separate problems. Chapter II develops a multirate form of the Wiener-Hopf equation for optimal filtering using least squares methods and presents results using this filter. Chapter III describes an adaptive multirate filter and shows results in the context of an adaptive noise cancellation algorithm. Chapter IV presents conclusions and recommendations for future studies. The Appendix provides details about the various test data used in this work.

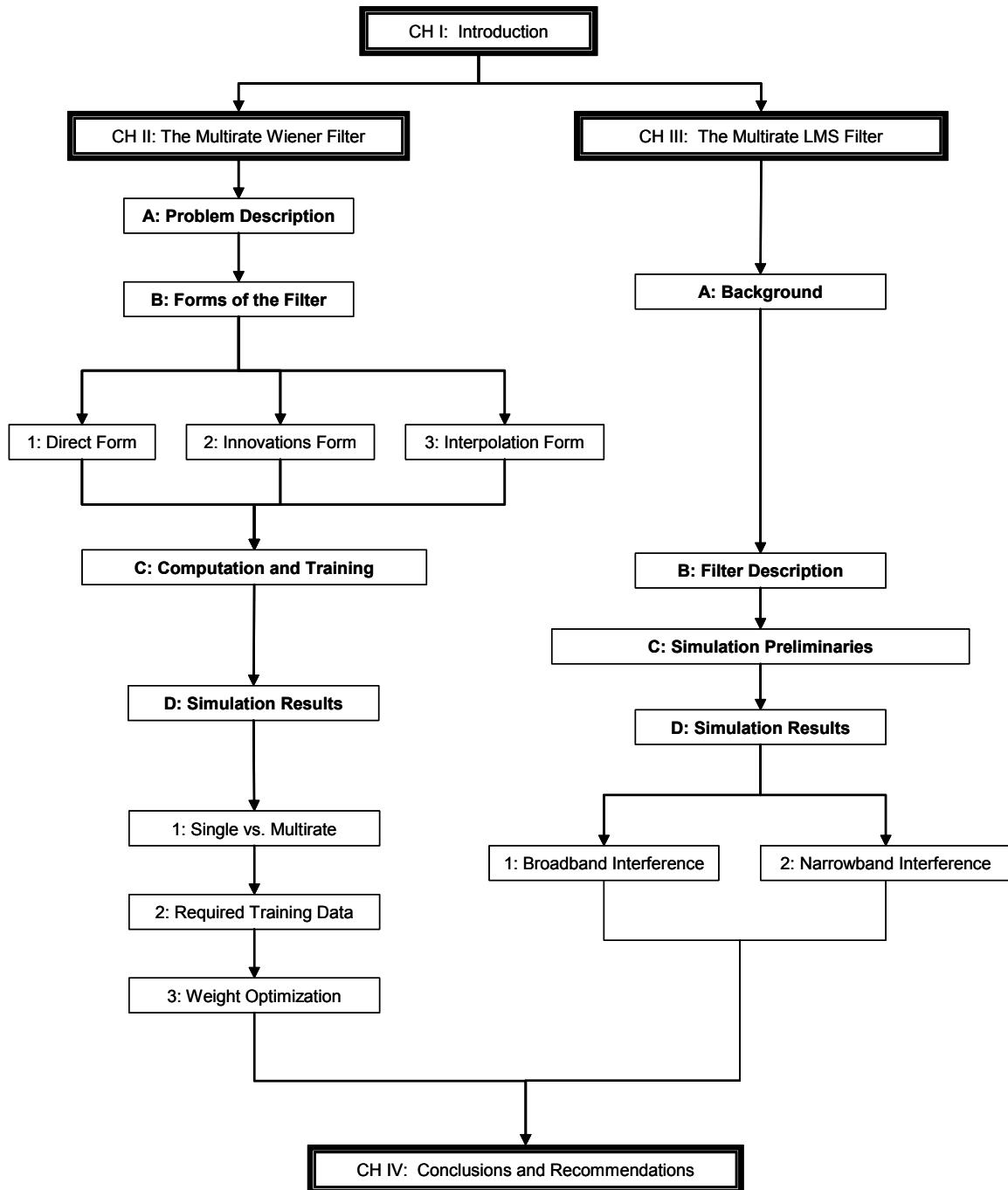

Figure 1. Thesis Outline Flow Diagram.

II. THE MULTIRATE WIENER FILTER

This chapter discusses three (non-adaptive) forms of the optimal multirate filter. Quantitative results comparing the single-rate and multirate Wiener filters are given. The amount of training data required to estimate the filter coefficients is addressed. In particular, the results of experiments using various lengths of training data are presented.

A. PROBLEM DESCRIPTION

The problem to be considered here is as follows. Given sensor data sampled at different rates and with different signal-to-noise ratios (SNR), optimally combine the data to form an estimate of the original signal. The system-level diagram for the case of two sensors is depicted in Figure 2.

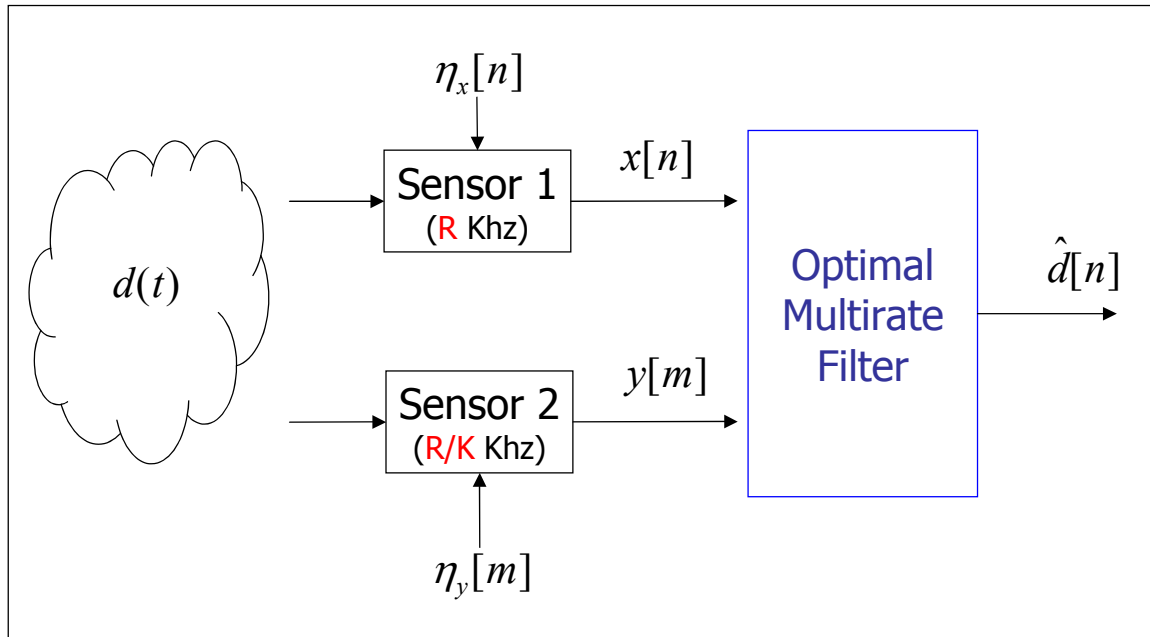

Figure 2. Overview of Estimation Process.

An underlying continuous-time signal $d(t)$ is monitored by two sensors which produce noisy observation sequences. The noise sequences are represented by $\eta_x[n]$ and $\eta_y[m]$ and are assumed to be additive. Different discrete time indices ‘ n ’ and ‘ m ’ are

used to indicate the different sampling rates. One sensor operates at a sampling rate of R kHz while the other samples at R/K kHz; the faster sampling rate is thus an integer multiple of the slower one. The factor K is the ratio between the two sensor data rates. Both data sequences are fed into a multirate filter where they are used to jointly produce an optimal estimate $\hat{d}[n]$ of the original signal $d(t)$. The estimate is needed or desired to be computed at the higher rate. Table 1 lists the notation used throughout this thesis.

Symbol	Meaning
$x[n]$	The data sequence which is sampled at the higher rate.
$y[m]$	The data sequence which is sampled at the lower rate.
$d[n]$	The desired signal to be estimated.
$\hat{d}[n]$	The estimate of the underlying signal $d[n]$.
P	The order of the filter that operates on the high-rate data $x[n]$.
Q	The order of the filter that operates on the low-rate data $y[m]$.
K	The ratio between the high and low sampling rates.
SNR_{high}	The signal-to-noise ratio of the high-rate data sequence $x[n]$.
SNR_{low}	The signal-to-noise ratio of the low-rate data sequence $y[m]$.
N	The length of the high-rate data sequence $x[n]$.
M	The length of the low-rate data sequence $y[m]$.
$\stackrel{ls}{=}$	Notation denoting the least squares solution to the equation.
n	The discrete time index of the high-rate data sequence.
m	The discrete time index of the low-rate data sequence.
$E\{\bullet\}$	The expected value of the expression inside the braces.
MSE	The mean-squared error between the desired signal and estimate.

Table 1. List of Notation.

B. THREE FORMS OF THE FILTER

Three possible forms of the filter were considered in this thesis. These are discussed separately below.

1. Direct Form

The direct form is the simplest and the most basic form of the filter; hence the name. Figure 3 illustrates the structure of this form of the optimal multirate filter.

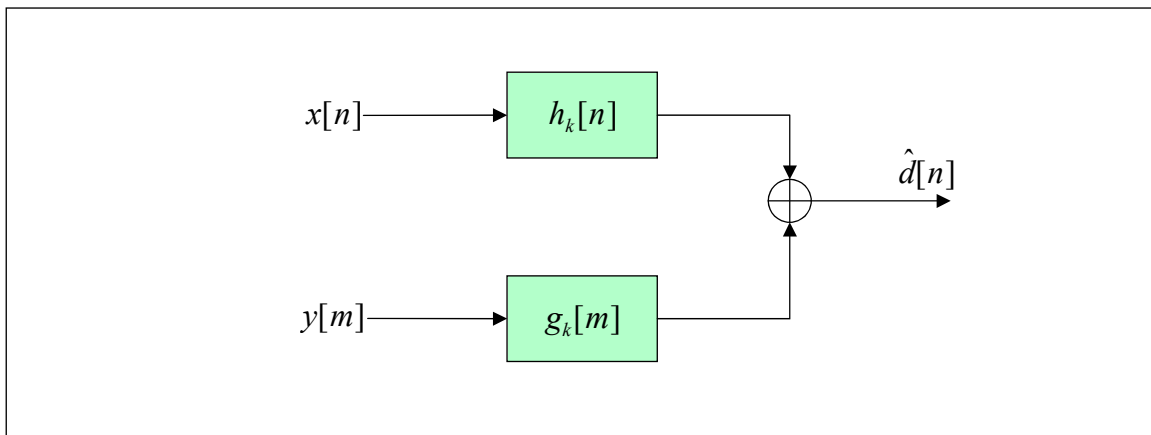

Figure 3. Direct Form of the Multirate Wiener Filter.

The two noisy sensor observation sequences $x[n]$ and $y[m]$ are simultaneously fed into separate time-varying linear filters. The filter $h_k[n]$ operates at the sampling rate of $x[n]$ while $g_k[m]$ operates at the sampling rate of $y[m]$. The two outputs are summed to produce the estimate $\hat{d}[n]$. The filters are to be chosen to minimize the mean-squared error (*MSE*) defined as $E\left\{\left(d[n] - \hat{d}[n]\right)^2\right\}$.

The simultaneous processing of data by these two filters leads to a periodic time dependency in the filter parameters. This is illustrated in Figure 4 and can be explained as follows.

Step	Filter Position		Illustration
	High-rate	Low-rate	
0	n_0	m_0	
1	$n_0 + 1$	m_0	
2	$n_0 + 2$	m_0	
3	$n_0 + 3$	$m_0 + 1$	

Figure 4. Internal Operation of Multirate Wiener Filter.

Recall that the time index of the high-rate filter is n while the time index of the low-rate filter is m . The estimate \hat{d} is to be produced at the high (full) rate. For the case illustrated in Figure 4, the order of the high-rate filter P is 4, the order of the low-rate filter Q is 2, and the ratio of sampling rates K is 3. The filters $h_k[n]$ and $g_k[m]$ are positioned at the corresponding starting points n_0 and m_0 in their respective data sequences. The estimate $\hat{d}[n_0]$ is obtained with the filters in these positions. This is step zero in Figure 4. At step one, $\hat{d}[n_0 + 1]$ (i.e., the estimate for the following point of the high-rate data sequence) is found by sliding the high-rate filter $h_k[n]$ forward by one point *while the low-rate filter remains in place*. This is repeated for the estimate $\hat{d}[n_0 + 2]$, shown in step two in Figure 4. Finally at step three, the estimate $\hat{d}[n_0 + 3]$ is found by sliding both filters forward by one point in their respective sequences. Note that

at this step the filters are now in the same relative positions as the initial step and the process can be repeated. This continues for the entire length of the available data sequences. This pattern for processing the data is what causes the optimal filters to be linear periodically time-varying (LPTV). In general, the filters have K unique positions relative to each other. Each unique position contains a different set of data points and requires unique sets of filter coefficients for the estimate; hence $(P + Q)K$ filter parameters are needed to specify this filter.

a. Derivation of Estimate

The estimate of the desired signal can be written as:

$$\hat{d}[n] = \sum_{i=0}^{P-1} h_k[i]x[n-i] + \sum_{j=0}^{Q-1} g_k[j]y[m-j]. \quad (1)$$

The time sample n can be written as

$$n = Km + k; \quad k \equiv n(\text{mod } K). \quad (2)$$

The subscript k on the filter weights is to indicate that the filters are periodically time-varying with period K . If the filter weights used at the K^{th} step are written as

$$\mathbf{h}_k = [h_k[0] \quad h_k[1] \quad \cdots \quad h_k[P-1]]^T, \quad (3)$$

and

$$\mathbf{g}_k = [g_k[0] \quad g_k[1] \quad \cdots \quad g_k[Q-1]]^T \quad (4)$$

while the observation vectors are defined as

$$\mathbf{x}[n] = [x[n] \quad x[n-1] \quad \cdots \quad x[n-(P-1)]]^T \quad (5)$$

and

$$\mathbf{y}[m] = [y[m] \quad y[m-1] \quad \cdots \quad y[m-(Q-1)]]^T. \quad (6)$$

Then (1) can be written as

$$\hat{d}[n] = \mathbf{h}_k^T \mathbf{x}[n] + \mathbf{g}_k^T \mathbf{y}[m]; \quad k \equiv n(\text{mod } K). \quad (7)$$

b. Least Squares Formulation

Least squares methods offer a convenient and data-dependent way to solve for the filter parameters. In order to pose the problem in terms of least squares methods, define the data vector

$$\mathbf{d} = [d[n_0] \quad d[n_0 + 1] \quad \cdots \quad d[n_0 + (N - 1)]]^T \quad (8)$$

where n_0 is the initial point of the estimate and N is the number of samples. Define the data matrices as:

$$\mathbf{X} = \begin{bmatrix} \mathbf{x}^T[n_0] \\ \mathbf{x}^T[n_0 + 1] \\ \vdots \\ \mathbf{x}^T[n_0 + (N - 1)] \end{bmatrix} \quad \mathbf{Y} = \begin{bmatrix} \mathbf{y}^T[m_0] \\ \mathbf{y}^T[m_0 + 1] \\ \vdots \\ \mathbf{y}^T[m_0 + (M - 1)] \end{bmatrix} \quad (9)$$

where n_0 and m_0 are the corresponding starting points in the observations sequences and $N = KM$. Following the notation in [6] we can write

$$[\mathbf{X}_k \quad \mathbf{Y}] \begin{bmatrix} \mathbf{h}_k \\ \mathbf{g}_k \end{bmatrix} \stackrel{ls}{=} \mathbf{d}_k \quad k \equiv n(\text{mod } K) \quad (10)$$

where the vector of values to be estimated \mathbf{d}_k is formed from the data vector \mathbf{d} by taking every K^{th} element beginning with element $k + 1$. Likewise, \mathbf{X}_k is formed from \mathbf{X} by taking every K^{th} row of \mathbf{X} beginning with row $k + 1$. The notation $\stackrel{ls}{=}$ denotes a least squares solution which minimizes the squared error between the left and right sides of the equation. The solution is well known and is given by

$$\begin{bmatrix} \mathbf{h}_k \\ \mathbf{g}_k \end{bmatrix} = [\mathbf{X}_k \quad \mathbf{Y}]^+ \mathbf{d}_k \quad k \equiv n(\text{mod } K) \quad (11)$$

where ‘+’ denotes the Moore–Penrose pseudoinverse of the matrix $[\mathbf{X}_k \ \mathbf{Y}]$. The mean–squared error is given by:

$$MSE = \frac{1}{N} \sum_{n=0}^{N-1} d[n] (d[n] - \hat{d}[n]) \quad (12)$$

which after substituting Equation (2) and (6) can be written as

$$MSE = \sum_{k=0}^{K-1} \sum_{m=0}^{M-1} d[Km+k] (d[Km+k] - \mathbf{h}_k^T \mathbf{x}[Km+k] - \mathbf{g}_k^T \mathbf{y}[m]). \quad (13)$$

This last equation can be written in vector and matrix notation as

$$MSE = \frac{1}{N} \sum_{n=0}^{N-1} (\mathbf{d}_k^{*T} \mathbf{d}_k - \mathbf{d}_k^{*T} \mathbf{X}_k \mathbf{h}_k - \mathbf{d}_k^{*T} \mathbf{Y} \mathbf{g}_k) \quad (14)$$

where \mathbf{d}_k and \mathbf{X}_k are formed as in the discussion following Equation (10).

2. Innovations Form

The innovations form of the filter, shown in Figure 5, explicitly shows how the low–rate observation sequence contributes to the estimate. The filter $h^0[n]$ in the top branch is time–invariant and is the optimal filter that would be used if the low–rate data were not present. The filter $H_k[n]$ is used to predict the low–rate data from the high–rate data. The prediction error sequence, which is the innovations sequence, is sent to the filter in the lower branch. Consequently, the output of the lower branch constitutes the additional information provided by the low–rate observations. The explicit handling of this new information is the reason the name ‘innovations’ is used for this form of the filter.

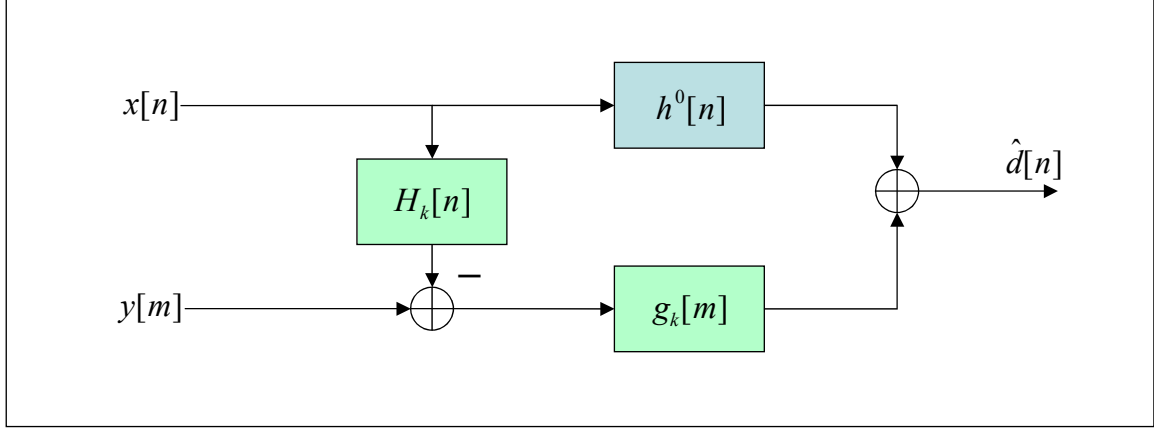

Figure 5. Innovations Form of Multirate Wiener Filter.

This form of the filter can be derived as follows. Using some results from the theory of generalized inverses [8], Equation (10) can be written in partitioned form as

$$\begin{aligned}
 \begin{bmatrix} \mathbf{h}_k \\ \mathbf{g}_k \end{bmatrix} &= [\mathbf{X}_k \quad \mathbf{Y}]^+ \mathbf{d}_k \\
 &= \begin{bmatrix} \mathbf{X}_k^+ - \mathbf{X}_k^+ \mathbf{Y} \mathbf{C}^+ \\ \mathbf{C}^+ \end{bmatrix} \mathbf{d}_k \\
 &= \begin{bmatrix} \mathbf{X}_k^+ \mathbf{d}_k - \mathbf{X}_k^+ \mathbf{Y} \mathbf{C}^+ \mathbf{d}_k \\ \mathbf{C}^+ \mathbf{d}_k \end{bmatrix}
 \end{aligned} \tag{15}$$

where $\mathbf{C} = (\mathbf{I} - \mathbf{X}_k \mathbf{X}_k^+) \mathbf{Y}$. From the above equation it can be seen that, if \mathbf{H}_k is defined as $\mathbf{H}_k = \mathbf{X}_k^+ \mathbf{Y}$, then the high-rate part of the filter can be written as

$$\mathbf{h}_k = \mathbf{h}_k^o - \mathbf{H}_k \mathbf{g}_k \tag{16}$$

where $\mathbf{h}_k^o = \mathbf{X}_k^+ \mathbf{d}_k$ is the optimal filter when estimating the data using only the high-rate observations. In a stochastic process framework, this filter would not be a function of k due to the stationarity of the data [4]. However in this least squares framework, the filter does depend on k , with \mathbf{h}_k^o converging to a common value for long data sequences. The filter estimate can now be written as

$$\begin{aligned}\hat{d}[n] &= \mathbf{h}_k^{oT} \mathbf{x}[n] - \mathbf{g}_k^T \mathbf{H}_k^T \mathbf{x}[n] + \mathbf{g}_k^T \mathbf{y}[m] \\ &= \mathbf{h}_k^{oT} \mathbf{x}[n] + \mathbf{g}_k^T (\mathbf{y}[m] - \mathbf{H}_k^T \mathbf{x}[n]) .\end{aligned}\tag{17}$$

This produces the form of the filter shown in Figure 5.

3. Interpolation Form

This form of the filter avoids the need for time-varying filters to process the data sequences. A diagram is shown in Figure 6. In this form, the low-rate data is interpolated to the high-rate. Both data sequences are then processed by time-invariant filters.

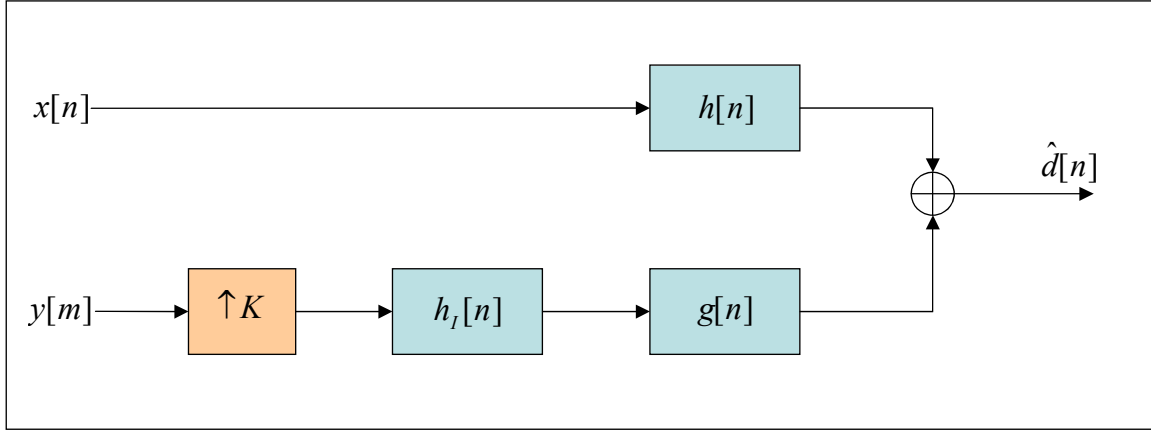

Figure 6. Interpolation Form of Multirate Wiener Filter.

In this realization, all of the branch filters are time-invariant. This filter works as long as the input is stationary. This can be achieved if the low-rate data and corresponding interpolation filter are bandlimited to $\pm\pi/K$ [5]. However the ideal interpolation filter is non-causal and, so, a causal approximation has to be used for this form. This may require the causal approximation filter to be of very high order.

C. COMPUTATIONAL REQUIREMENTS

In comparing the various realizations of the optimal multirate filter, a matter of concern is the number of filter parameters required as well as the number of operations

(multiplications and additions) at each time step. Table 2 lists these quantities for each form of the filter.

<i>Form of Optimal Filter</i>	<i>Filter Parameters</i>	<i>Operations / Unit Time</i>
Direct	$(P + Q)K$	$P + Q$
Innovations	$P + PQK + QK$	$P + PQ + Q$
Interpolation	$P + QK$	$P + QK + I$

Table 2. Computational Requirements for the Three Forms of the Filter.

The direct form of the multirate filter, being the *least* computationally expensive of the three forms, requires $(P + Q)K$ coefficients. A corresponding single-rate filter would require only P coefficients, which differs by approximately a factor of K . Notice however that the number of operations per unit time is $P + Q$ which does *not* depend on K . This means that the computational requirement at each time step is the same as a filter with a fixed set of coefficients (i.e., a linear time-invariant filter).

The innovations form is the most computationally expensive of the three forms of the filter due to the prediction filter \mathbf{H}_k . There are PQK more filter parameters than for the interpolation form due to the prediction process. Additionally, the prediction filter results in PQ more operations than needed using the direct form. This form would not likely be used in practice due to the extra computational cost over the direct form. This form is useful, however, in analyzing the reduction in MSE due to the presence of the low-rate observations.

The interpolation form of the filter requires the fewest number of parameters $P + QK$ (the filter $g[n]$ is assumed to be of order QK since the low-rate data is interpolated by K up to the high rate). The number of operations is thus dependent on K and also depends on the order I of the interpolation filter, which can become the dominant part of the computation.

The length of data needed in solving for these parameters is a valid practical concern, and is addressed in the next section.

D. SIMULATION RESULTS

1. Preliminaries

Since MSE was used as the criterion for the development of the filters, it was also used to measure filter performance in this study. The mean-squared error in decibels (MSE_{dB}), defined as $MSE_{dB} = 10 \log_{10} MSE$, is used in the following discussion. The data used for these experiments is described in the Appendix.

2. Multirate vs. Single-rate Filter

In comparing the performance of the multirate and single-rate filters, a reasonable question to ask is “How much is performance improved (if at all) over using either of the data sequences alone?” This question can be answered by comparing the performance of the multirate filter to that of a single-rate Wiener filter on either of the data sequences separately. In the following experiment, the MSE was calculated while varying the order of the low-rate filter. The results are shown in Tables 3 and 4.

For the simulations described here, the order of the high-rate filter P was 30 and the ratio of sampling rates K was 10. The SNR of the high-rate sequence was 0 dB. The SNR of the low-rate data sequence was 10 dB. The SNRs were obtained by adding channel noise to each of the observation sequences. The data were split into two sets. One set of data, called the ‘training set,’ was used to design the filter. The filter was then applied to the second set of data, which was called the ‘test set.’ The length of both the training and test data sequences was 25,000 points. The use of both a training and test set helps judge performance of the filter with different, but statistically similar, data. The MSE on both the training and test sets was recorded; then the experiment was repeated using different realizations of sensor noise. The results were averaged over 100 trials of sensor noise.

Case[1]: The order of the low-rate filter was taken to be $Q = 3$. This means that the low-rate filter uses points covering the same time frame as the high-rate filter. Table 3 shows that using the high-rate observations alone leads to an MSE of approximately

9.8 dB on both training and test data. The low-rate observations, when used alone, result in a MSE of approximately 13.5 dB which is worse by about 3.7 dB. When both data sets are used together however, the MSE is about 7.6 dB which is about 2.2 dB better than using the high-rate data alone.

<i>Sensor</i>	<i>Mean-Squared Error</i>	
	<i>Training Set (dB)</i>	<i>Test Set (dB)</i>
High-rate	9.84	9.86
Low-rate	13.59	13.53
Both	7.65	7.64

Table 3. Mean-Squared Error for $Q = 3$ (100 trial average).

Case[2]: The order of the low-rate filter was taken to be $Q = 10$. This means that the low-rate filter uses points covering a much larger time frame than the high-rate filter. Table 4 shows that the MSE for the high-rate data alone remains at approximately 9.8 dB as before. The MSE for the low-rate data alone improves (compared to the previous experiment) to about 10.5 dB. The use of both data sets together in this experiment

<i>Sensor</i>	<i>Mean-Squared Error</i>	
	<i>Training Set (dB)</i>	<i>Test Set (dB)</i>
High-rate	9.84	9.86
Low-rate	10.67	10.53
Both	5.96	5.77

Table 4. Mean-Squared Error for $Q = 10$ (100 trial average).

results in a very significant improvement in performance. Specifically there is almost a 4 dB reduction in MSE over using the high-rate data alone and about 3 dB over using the low-rate data alone.

3. Required Training Data

The previous section discussed the computational requirements of the filter. Another matter of practical concern is the amount of training data needed to design the multirate filter. The length of data needed to solve for these parameters is investigated here. The following results are based on the same data used in the previous subsection.

For this experiment, the length of data used to design the filter was varied from 500 to 25,000 points in steps of 500 points. The other factors are as stated above and are reproduced here for continuity: the order of the low-rate filter P was 30, the ratio of sampling rates K was 10, the SNR of the high-rate sequence SNR_{high} was 0 dB, and the SNR of the low-rate sequence SNR_{low} was 10 dB. The error MSE_{dB} on both the training and test sets were computed and plotted. The length of data required for training was defined to be the length at which the relative error between the training and test sets came to within one percent. The results were averaged over 50 trials of sensor noise.

a. Low-rate Filter Order $Q = 3$

The figure shows plots of MSE vs. length of data set. The top pair of curves result when using low-rate data alone; the middle pair is for the high-rate data alone, while the bottom pair results when using both data sets. For each case, the dotted lines correspond to the training sets, and the solid lines to the test sets. The point at which the MSE on the training and test sets come to within one percent of each other is circled. Using low-rate data alone, it took 10,000 points of training data to reach the criterion point. The case of a low-rate filter order $Q = 3$ is depicted in Figure 7.

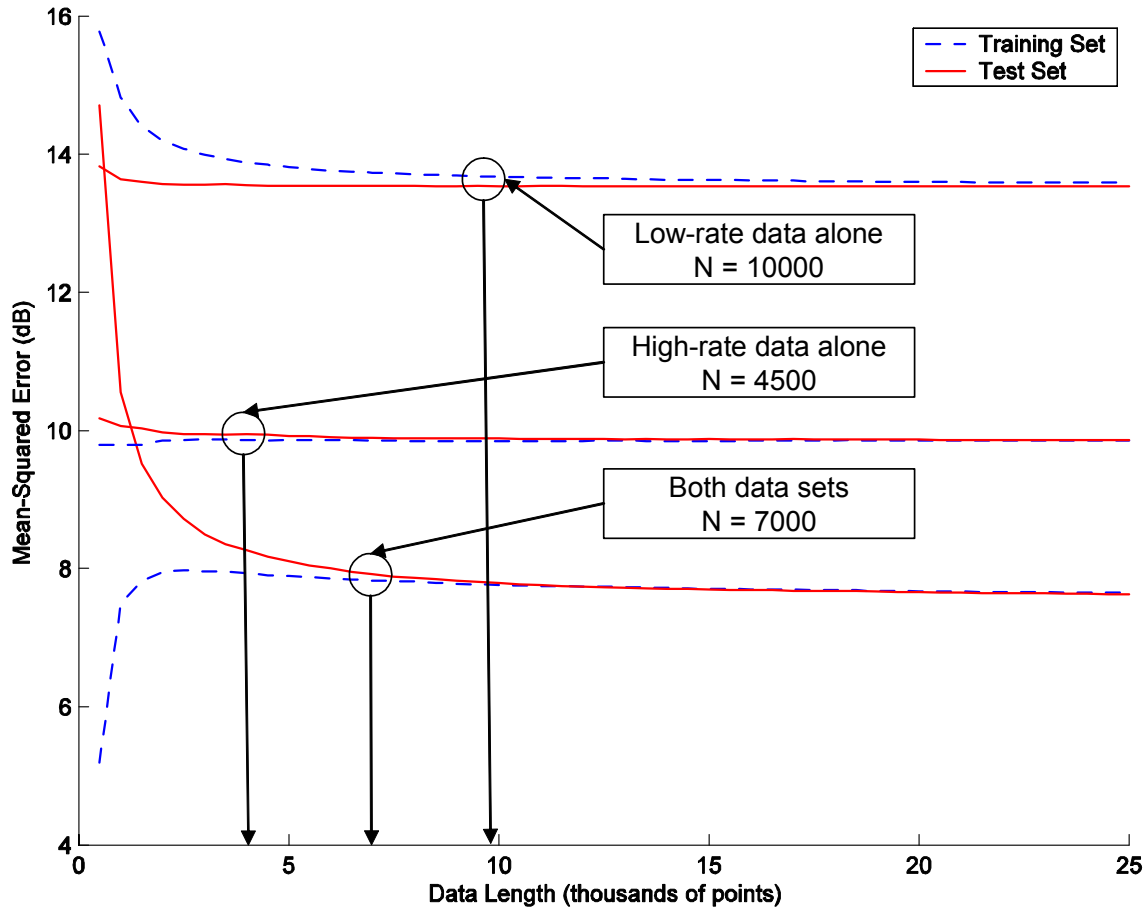

Figure 7. Mean-Squared Error versus Data Length for $Q = 3$. TOP: Low-rate data alone. MIDDLE: High-rate data alone. BOTTOM: Both data sets.

Using high-rate data alone, only 4,500 points were needed. Interestingly, using both data sets, only 7,000 points were needed. This is not an unreasonably high cost to design the multirate Wiener filter.

b. Low-rate Filter Order $Q = 10$

The above simulation was repeated using a low-rate filter order of $Q = 10$. Figure 8 shows the results graphically. Using low-rate data alone required over 25,000 points of data. Designing the filter using both observation sequences, however, required only 4,500 points of data. This turned out to be exactly the same as the number required for using the high-rate data alone.

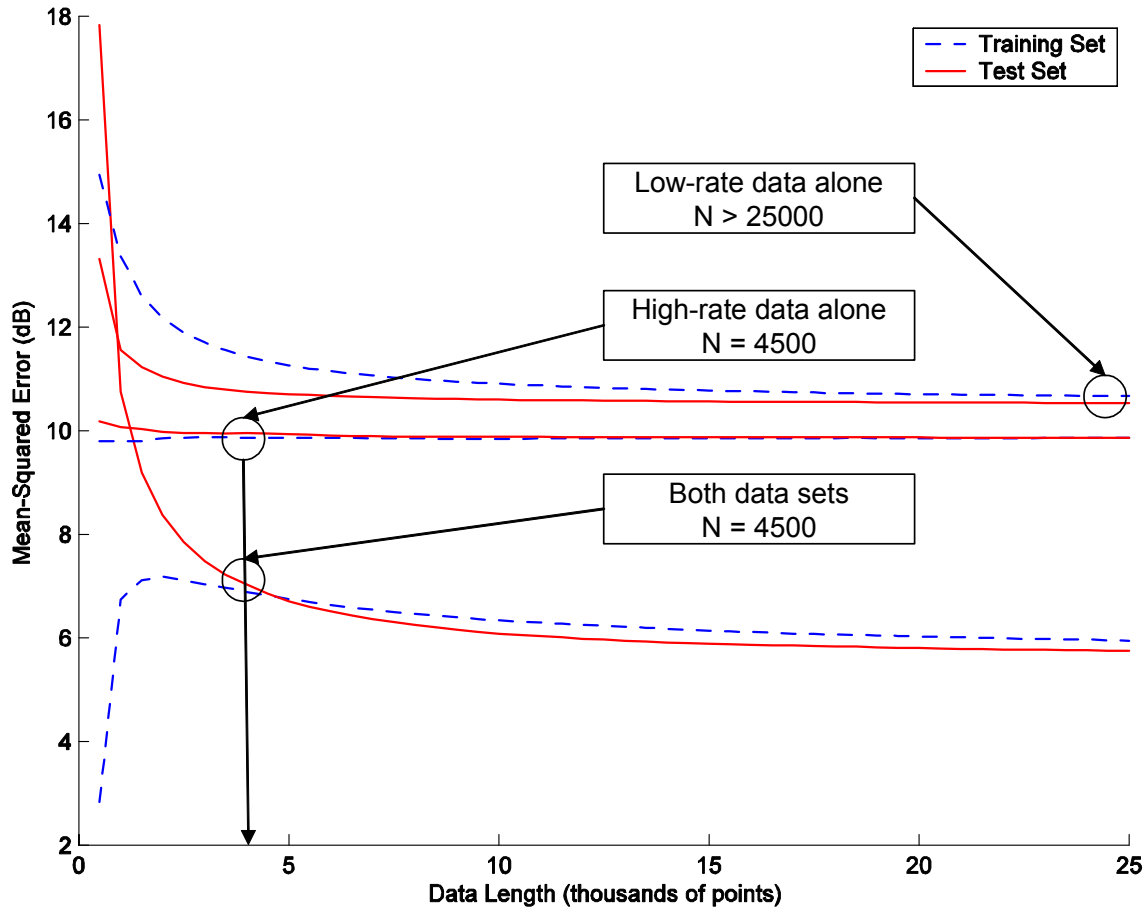

Figure 8. Mean-Squared Error versus Data Length for $Q = 10$. TOP: Low-rate data alone. MIDDLE: High-rate data alone. BOTTOM: Both data sets.

The results of these experiments indicate that the length of training data needed to estimate the filter coefficients is comparable to that when using time-invariant filters on either sequence alone.

4. Optimizing Filter Tap Weights

As part of this research, a parametric representation of the filter impulse response was sought to help to reduce the number of weights to compute. This representation would exploit possible patterns in the filter coefficients. It is the time-variant filters that cause the computations to increase. Therefore, the time-variant behavior of the filters was examined for a pattern to exploit.

The FM, AR, and SINE signals (see Appendix) were used for this experiment. For each of the signals, the high-rate and low-rate filters were examined for patterns. The time-varying nature of the filter coefficients, however, proved to be signal-dependent.

For example, a signal of length $L = 27,000$ points was used to design a multirate Wiener filter with two observations sequences under the following conditions: $P = 100$, $Q = 100$, $K = 20$, $SNR_{high} = 0$ dB, and $SNR_{low} = 10$ dB. These conditions yield $(100 + 100)20 = 4000$ filter weights (see Table 2). The filter coefficients $\mathbf{h}_k[n]$ and $\mathbf{g}_k[m]$ are plotted in Figure 9. Three-dimensional plots of the filter coefficients for the FM, AR, and SINE signals are shown. The left column of coefficients is for the high-rate filters, while the right column holds the low-rate coefficients. The time-varying axis is labeled ‘ k ’ denoting the cycle of the filter. The axis for the filter index is labeled ‘ n ’ or ‘ m ’ depending on whether it shows the index for high-rate or low-rate filter, respectively.

In analyzing Figure 9, we begin by considering the high-rate, time-variant filters (specifically, for the FM signal (Figure 9(a)), which resembles a two-dimensional wave). It seems that along the k axis, the filter values remain relatively constant with only minor fluctuations. This would also appear to be the case for the high-rate coefficients for the AR signal (Figure 9(c)) and SINE signal (Figure 9(e)). In addition, note that there is no general trend where the filter coefficients become small along the n or m direction, except for the case of the AR signal. A similar analysis applies to the low-rate filters. Begin with the low-rate filters for the FM signal (Figure 9(b)). There is no constant behavior along the time-varying axis. The low-rate coefficients of the AR signal (Figure 9(d)) and SINE signal (Figure 9(f)) exhibit similar behavior.

Two things are of note: 1) the constant behavior of the high-rate filters along the time-varying axis seems to validate the discussion of the innovations form of the filter. Specifically, the claim that the \mathbf{h}_k^o converge to a common value for long data sequences is supported; and 2) the filters appear to be *unique* for each type of signal estimated.

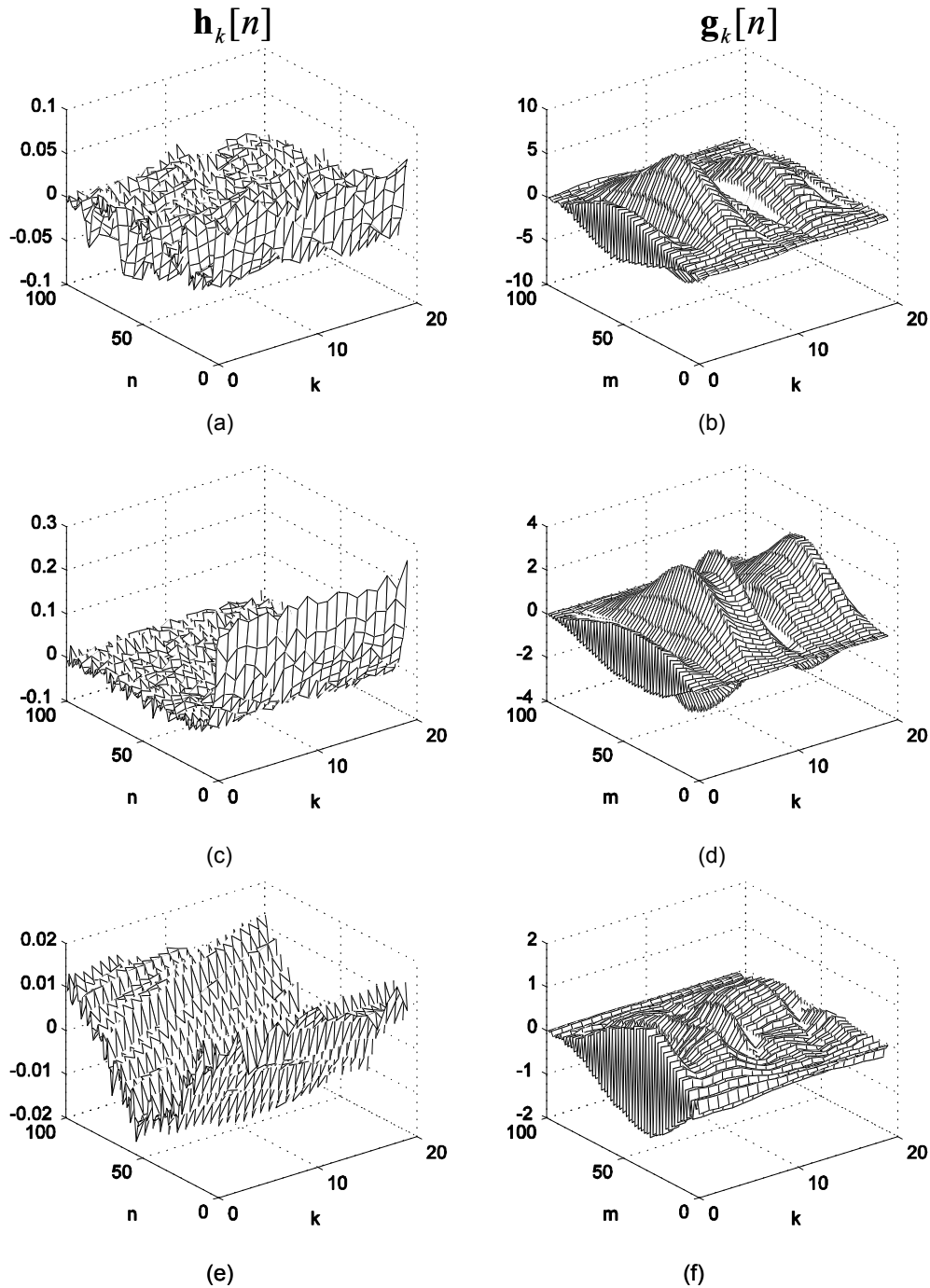

Figure 9. Sample time-varying filters used in multirate Wiener filtering. (a) FM Signal: High-rate weights, (b) FM Signal: Low-rate weights. (c) AR Signal: High-rate weights, (d) AR Signal: Low-rate weights. (e) SINE signal: High-rate weights, (f) SINE signal: Low-rate weights.

The foregoing results covered the non-adaptive forms of the filter. The next chapter introduces an adaptive form of the multirate filter, and provides results in the context of adaptive interference cancellation.

III. THE MULTIRATE LMS FILTER

This chapter presents an adaptive filtering method useful for applications where the statistics of the data are non-stationary. The algorithm is based on the least mean-squares (LMS) algorithm of Widrow and Hoff [9]. This application of the algorithm is in the context of interference removal. Results are given for broadband and narrowband interference in an adaptive noise cancellation (ANC) scenario.

A. BACKGROUND

Adaptive filtering is a wide discipline of which LMS and its variants are a significant part. In an adaptive filtering algorithm the data to be filtered is employed to find the optimum filter tap weights.

The basic, *single-rate* LMS algorithm offers a low cost, elegant solution to adaptive filtering. An arbitrary initial set of filter coefficients is chosen and updated at each time step n and new observation. If the data is wide-sense stationary and the algorithm step size parameter (see below) is chosen appropriately, the filter coefficients will approach the optimal coefficients defined by the Wiener-Hopf equations. The nature of this convergence is discussed in many places [7, 12]. If the data is non-stationary and slowly time-varying, the filter coefficients tend to ‘track’ the optimal time-varying filter for the data. In the basic LMS method the filter coefficient vector \mathbf{w} is updated at each time step n according to the equation [6]

$$\mathbf{w}[n+1] = \mathbf{w}[n] + \mu e[n] \mathbf{x}[n] \quad (18)$$

where

$$e[n] = d[n] - \mathbf{w}^T[n] \mathbf{x}[n] \quad (19)$$

is the error found at time step n and μ is a parameter called the ‘step size.’ For suitably chosen values of the step size, the weights will converge to a solution close to that of the optimal (Wiener) filter. For practical purposes, the bounds on the step size are [7]

$$0 < \mu < \frac{2}{PR_x[0]} \quad (20)$$

where P is the order of the filter and $R_x[0]$ is the value of the autocorrelation sequence of the input signal at lag zero (i.e., the signal power).

B. FILTER DESCRIPTION

The *multirate* LMS estimation algorithm extends the LMS algorithm to the case where multiple inputs at different sampling rates are available. Accordingly for the multirate case, the equations are slightly more complicated. In this discussion it is assumed, as in the previous chapter, that two inputs are available (see Figure 10) and these are to be used jointly to estimate the ‘desired’ signal $d[n]$.

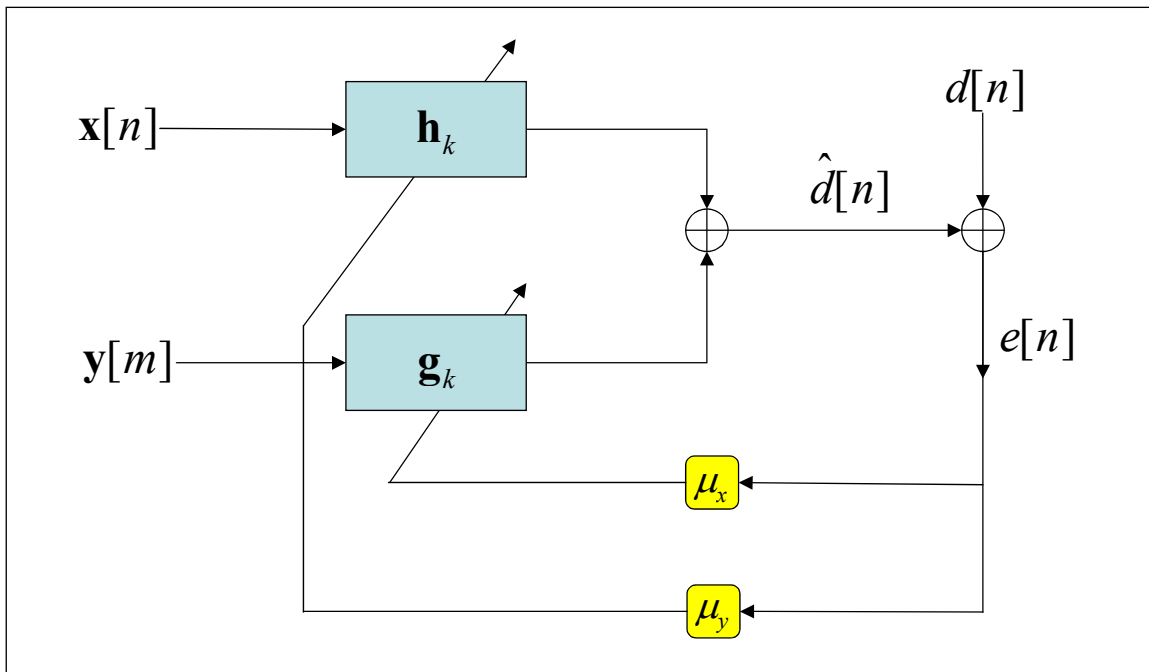

Figure 10. Simplified Diagram of Multirate LMS Filter.

The input x is sampled at the full rate, i.e., the rate of the output estimate. The input y is sampled at a rate of $1/K$ times the full rate. Again at any time n , one can write $n = Km + k$ for $k = 0, 1, \dots, K-1$. Therefore, define a vector of high-rate data points as

$$\mathbf{x}[n] = [x[n] \quad x[n-1] \quad \cdots \quad x[n-(P-1)]]^T \quad (21)$$

and a corresponding vector of low-rate data points as

$$\mathbf{y}[m] = [y[m] \quad y[m-1] \quad \cdots \quad y[m-(Q-1)]]^T. \quad (22)$$

The estimate is then of the form

$$\hat{d}[n] = \mathbf{h}_k^T \mathbf{x}[n] + \mathbf{g}_k^T \mathbf{y}[m]; \quad n = Km + k. \quad (23)$$

In the absence of adaptation the filter coefficients would be periodic, i.e., at any times n_1 and n_2 such that $n_1 \pmod K = n_2 \pmod K = k$ the coefficient vectors are \mathbf{h}_k and \mathbf{g}_k . For the multirate LMS algorithm these coefficient vectors are updated in time. The coefficient vectors at any time n will be denoted by $\mathbf{h}_k[m]$ and $\mathbf{g}_k[m]$ (where $n = Km + k$). The estimate is thus given by

$$\hat{d}[n] = \mathbf{h}_k^T[m] \mathbf{x}[n] + \mathbf{g}_k^T[m] \mathbf{y}[m]; \quad k \equiv n \pmod K. \quad (24)$$

The error is then given by

$$e[n] = d[n] - \hat{d}[n]. \quad (25)$$

The update steps in the multirate LMS algorithm are defined by

$$\mathbf{h}_k[m+1] = \mathbf{h}_k[m] + \mu_x e[n] \mathbf{x}[n] \quad (26)$$

and

$$\mathbf{g}_k[m+1] = \mathbf{g}_k[m] + \mu_y e[n] \mathbf{y}[m]. \quad (27)$$

The complete algorithm is more easily specified with a double index. It is listed in this way in Table 5 and depicted graphically in Figure 11.

Step	Equation
(a)	$\mathbf{x}_k[i] = [x[n_0 + iK + k] \quad x[n_0 + iK + k - 1] \quad \cdots \quad x[n_0 + iK + k - P + 1]]$ $\mathbf{y}[i] = [y[m_0 + i] \quad y[m_0 + i - 1] \quad \cdots \quad y[m_0 + i - Q + 1]]$
(b)	$\hat{d}_k[i] = \mathbf{h}_k^T[i] \mathbf{x}_k[i] + \mathbf{g}_k^T[i] \mathbf{y}[i]$
(c)	$d_k[i] = d[n_0 + iK + k]$
(d)	$e_k[i] = d_k[i] - \hat{d}_k[i]$
(e)	$\mathbf{h}_k[i+1] = \mathbf{h}_k[i] + \mu_x e_k[i] \mathbf{x}_k[i]$ $\mathbf{g}_k[i+1] = \mathbf{g}_k[i] + \mu_y e_k[i] \mathbf{y}[i]$

Table 5. Listing of the Multirate LMS algorithm.

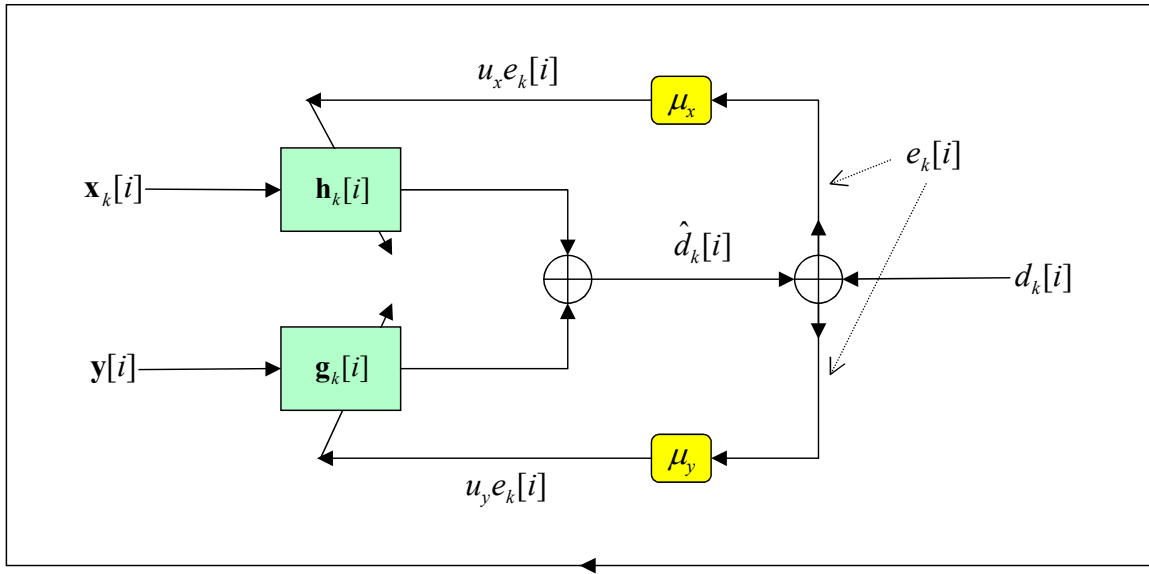

Figure 11. Detailed Diagram of Multirate LMS Algorithm.

The equations in Table 5 require some explanation. The time-varying data filters have period K , so there are PK weights needed for the high-rate filter and QK weights

needed for the low-rate filter. For the high-rate case, if we define a P by K matrix containing all high-rate coefficients

$$\mathbf{H}[i] = \begin{bmatrix} \vdots & \vdots & \cdots & \vdots \\ \mathbf{h}_0[i] & \mathbf{h}_1[i] & \cdots & \mathbf{h}_{K-1}[i] \\ \vdots & \vdots & \cdots & \vdots \end{bmatrix} \quad (28)$$

whose columns represent the filter at each step $k = 0, 1, \dots, K-1$ in its period, then we see that only *one* column of $\mathbf{H}[i]$ is updated for each point of the output sequence that is estimated (see Table 5). Beginning the estimation at corresponding points n_0 and m_0 of the observation sequences, the filter $\mathbf{h}_0[0]$ is found. Then the input matrix $\mathbf{x}_k[i]$ is updated and used to find $\mathbf{h}_1[0]$. The process continues until all K columns of $\mathbf{H}[i]$ have been updated, at which time the cycle repeats. The coefficients for the k^{th} step in the cycle of the time-varying filter \mathbf{h}_k are therefore updated at every K^{th} point of the original sequence.

A similar discussion applies to the low-rate coefficients. The complete set of coefficients are contained in a Q by K matrix

$$\mathbf{G}[i] = \begin{bmatrix} \vdots & \vdots & \cdots & \vdots \\ \mathbf{g}_0[i] & \mathbf{g}_1[i] & \cdots & \mathbf{g}_{K-1}[i] \\ \vdots & \vdots & \cdots & \vdots \end{bmatrix}. \quad (29)$$

A particular column \mathbf{g}_k is then updated at every K^{th} point of the original data sequence.

C. SIMULATION PRELIMINARIES

The multirate LMS filter was tested in the context of adaptive interference cancellation, also known as adaptive noise cancellation (ANC). Results are given for both narrowband and broadband interference. For the basic, single-rate LMS ANC the primary input contains the signal plus interference. The so-called ‘reference’ input contains a correlated version of the interference that the adaptive filter uses to cancel the interference in the primary input.

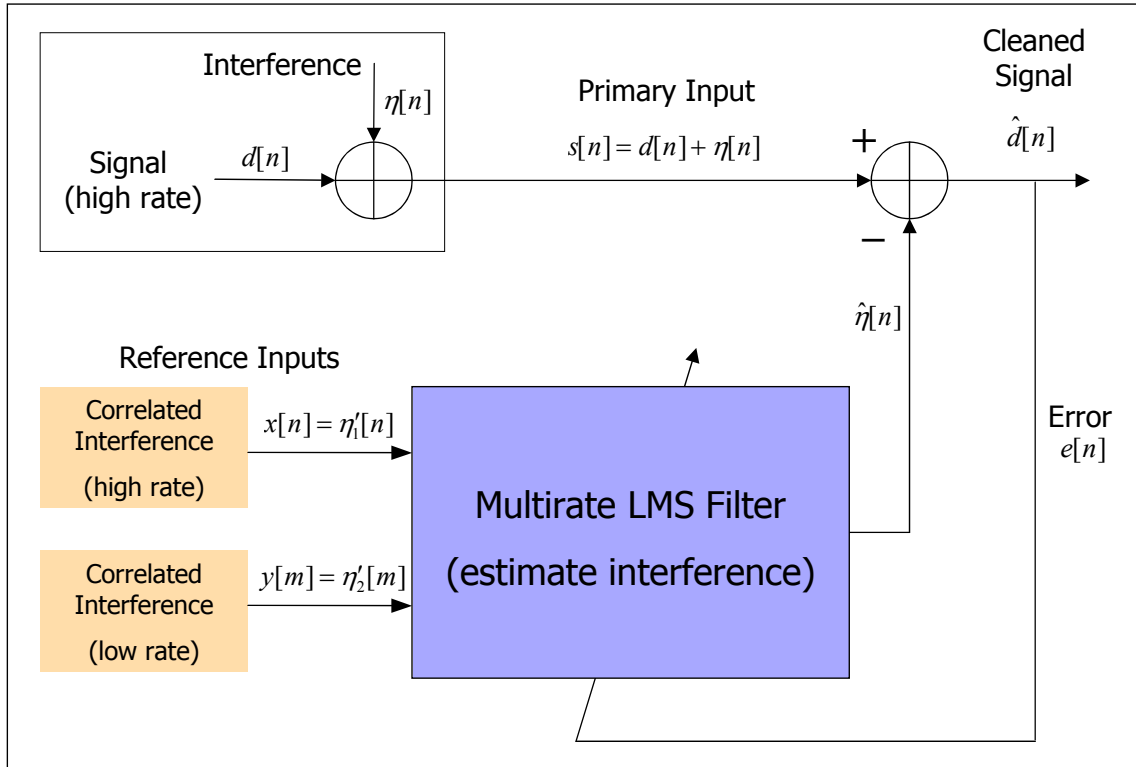

Figure 12. Adaptive Interference Cancellation with Two Reference Inputs.

The ANC extended to the case of multiple reference inputs is shown in Figure 12. The inputs to the filter now contain multiple versions of the interference, sampled at different rates. The goal of the LMS filter is to estimate the interference present in the reference input (at the full rate) from two noisy independent observations of the interference. A case of some interest is the case where the only reference signal is $y[m]$. In other words, the reference signal is at a lower rate compared to the primary input $s[n]$ and the cleaned signal $\hat{d}[n]$. In this case it may be able to perform the ANC with fewer samples (in time) of the correlated interference.

D. SIMULATION RESULTS

Results for both narrowband and broadband interference are presented in this section.

1. Narrowband Interference

In this experiment the interference consisted of tonal ‘noise’ added to recorded speech. Two sinusoidal tones of frequency 4410 and 8820 Hz were added to a segment of speech. The first tone was added at the start of the speech signal, and the second tone added in the middle of the sequence. The original speech signal and corrupted version are shown in Figure 13 below.

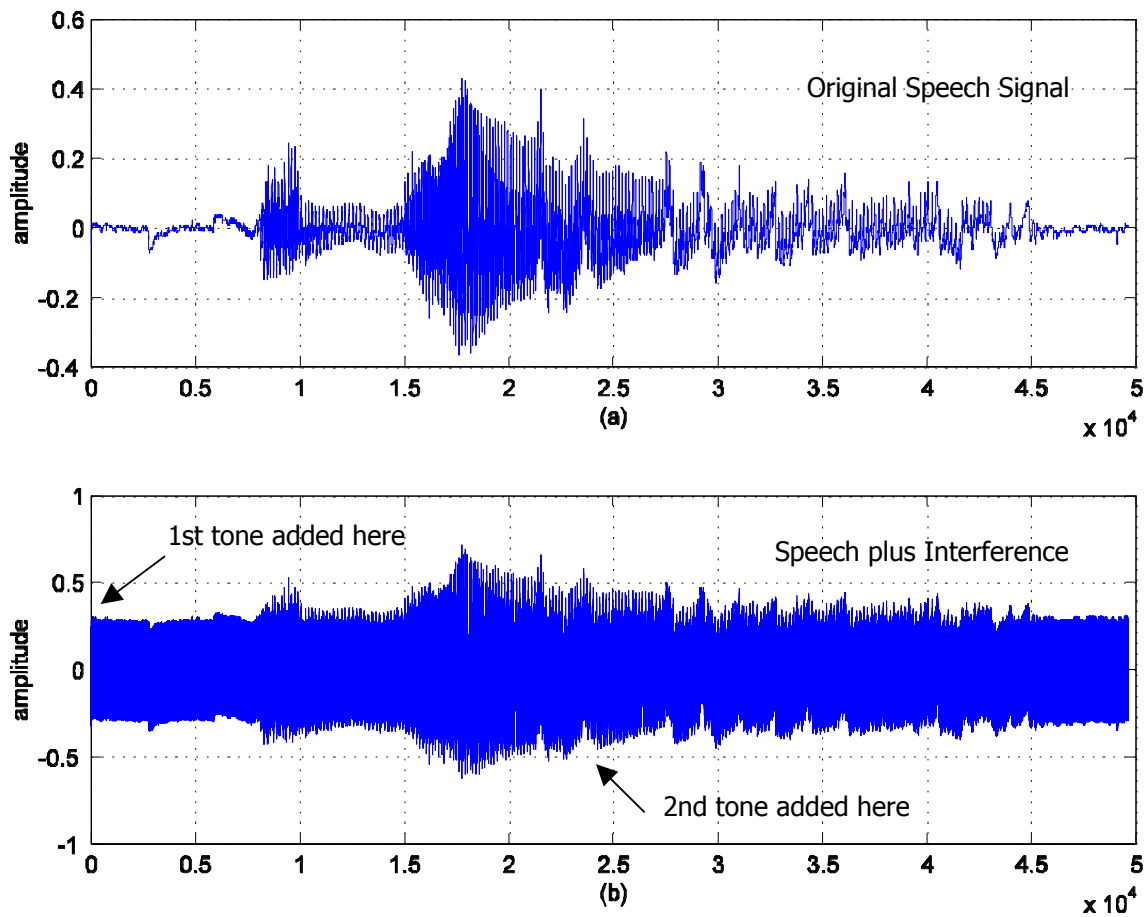

Figure 13. Plot of voice signal of the spoken word ‘hello’ used in narrowband interference simulation. (a) Original speech signal. (b) Speech signal including tones.

The test signal for this experiment was a recording of the spoken word ‘hello’ with a prolonged ‘o.’ The sample of speech was two seconds long and sampled at 22.05 kHz. The waveform is shown in Figure 13(a). Two sinusoidal tones were added to the signal. A tone of 4.41 kHz was added at the beginning of the speech segment. At the midpoint of the speech segment, this first tone was ended and a second tone of 2.205 kHz was added for the remainder of the speech signal. The reference input was generated by sending the interference signal through a third-order FIR filter and downsampling the result (see Appendix). The corrupted signal is shown in Figure 13(b) and illustrates the adverse effect of the interference on signal quality.

The parameters chosen were as follows. The high-rate filter order P was 2, the low-rate filter order Q was 2, the SNR of the high-rate sequence SNR_{high} was 0 dB, and the SNR of the low-rate sequence SNR_{low} was 10 dB. The number of samples required for the filter to mute the initial sinusoid is used as a measure of speed of convergence below. The original speech signal is reproduced in Figure 14(a) for comparison with the following results.

a. Using Both Observation Signals

The corrupted signal was filtered using the parameters described above; a sampling rate ratio of $K = 4$ was used. The resulting MSE was -14.15 dB. It took approximately 4,575 samples to mute the initial sinusoid in this case. For the given sampling rate of 22.05 kHz, this corresponds to only 0.21 seconds. This is slow for channel equalization in a communications system, but may suffice for certain audio applications. The filtered signal is shown in Figure 14(b). The spikes in the sequence at samples zero and 25,000 are the points at which the sinusoids were added.

b. Using Low-Rate Observations Alone

In this case, the corrupted signal is filtered using the low-rate observation sequence *as the only reference input*. The low-rate observation sequence has a sampling rate of 5.51 kHz. The multirate LMS filter estimates the interference at the full rate of

22.05 kHz, using these samples. All other simulation parameters are the same as the previous case. The filtered signal is shown in Figure 14(c). For this case, the filter took approximately 6550 samples (0.3 sec) to mute the initial sinusoid. The resulting MSE was -12.91 dB.

This experiment was also performed using a longer segment of speech taken from the cockpit of a military jet; similar results were obtained.

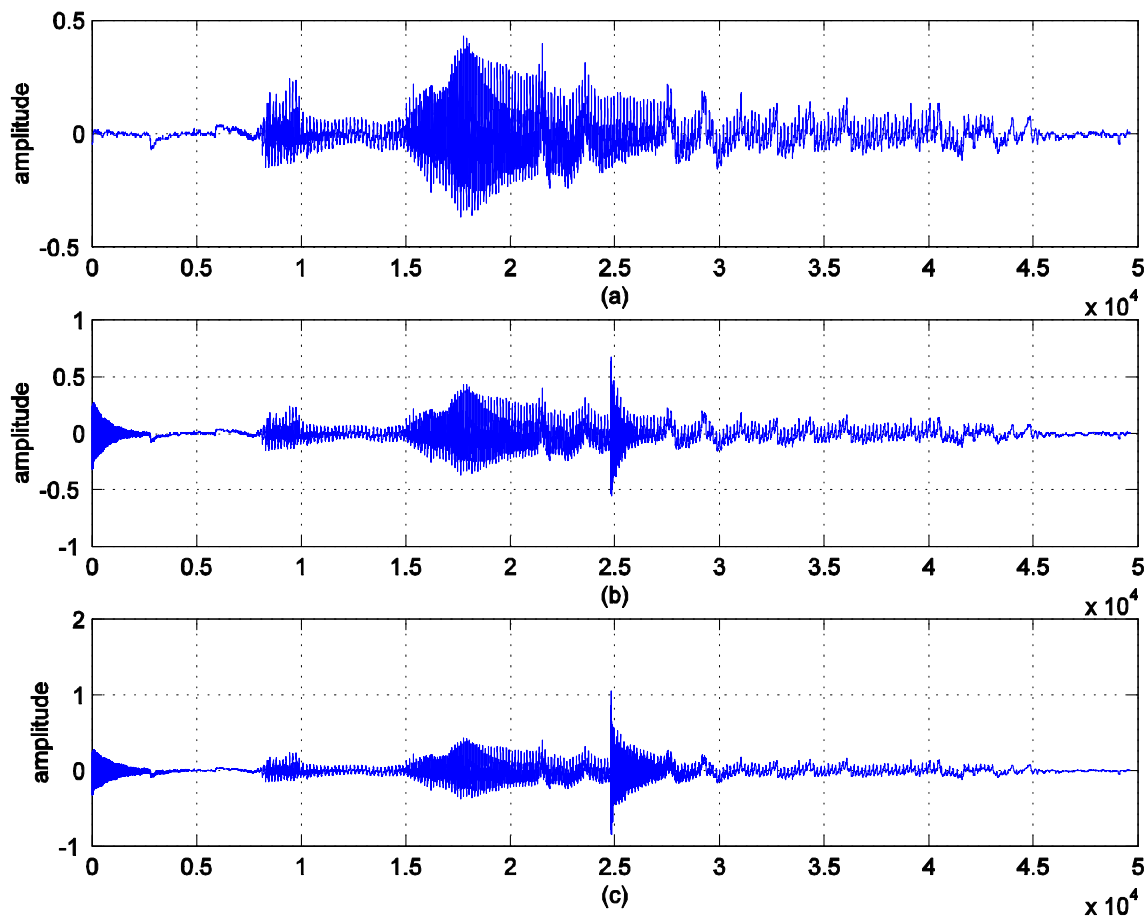

Figure 14. Signals after filtering. (a) Original speech signal. (b) Filtered signal using both data sequences with $K = 4$. (c) Filtered signal using low-rate data alone with $K = 4$.

2. Broadband Interference

An adaptive interference scenario was also used for this scenario. The desired signal for this experiment was a segment of radio traffic from an air traffic control center. The interference was a spoken phrase of speech, which is a broadband signal. The

reference input was generated by sending the interference signal through an FIR filter (see Appendix) and then downsampling the resulting sequence by a factor of K . The interference was removed using the low-rate observations alone. The parameters for this simulation were: the order of the low-rate filter $Q = 40$, the low-rate SNR was $SNR_{low} = -0.26$ dB, the sampling rate ratio was $K = 4$. The SNR of the filtered sequence was 9.65 dB, which is an improvement of 9.91 dB. The supporting plots are shown in Figure 15. The original speech signal and is shown in Figure 15(a) and exhibits some clipping. The speech corrupted with interference is shown in Figure 15(b). The filtered signal is shown in Figure 15(c). Figures 15(d) and (e) show the actual and estimated interference signal, respectively.

The foregoing discussion constitutes the penultimate results of this thesis. The next chapter summarizes the conclusions of this research and offers suggestions for future work.

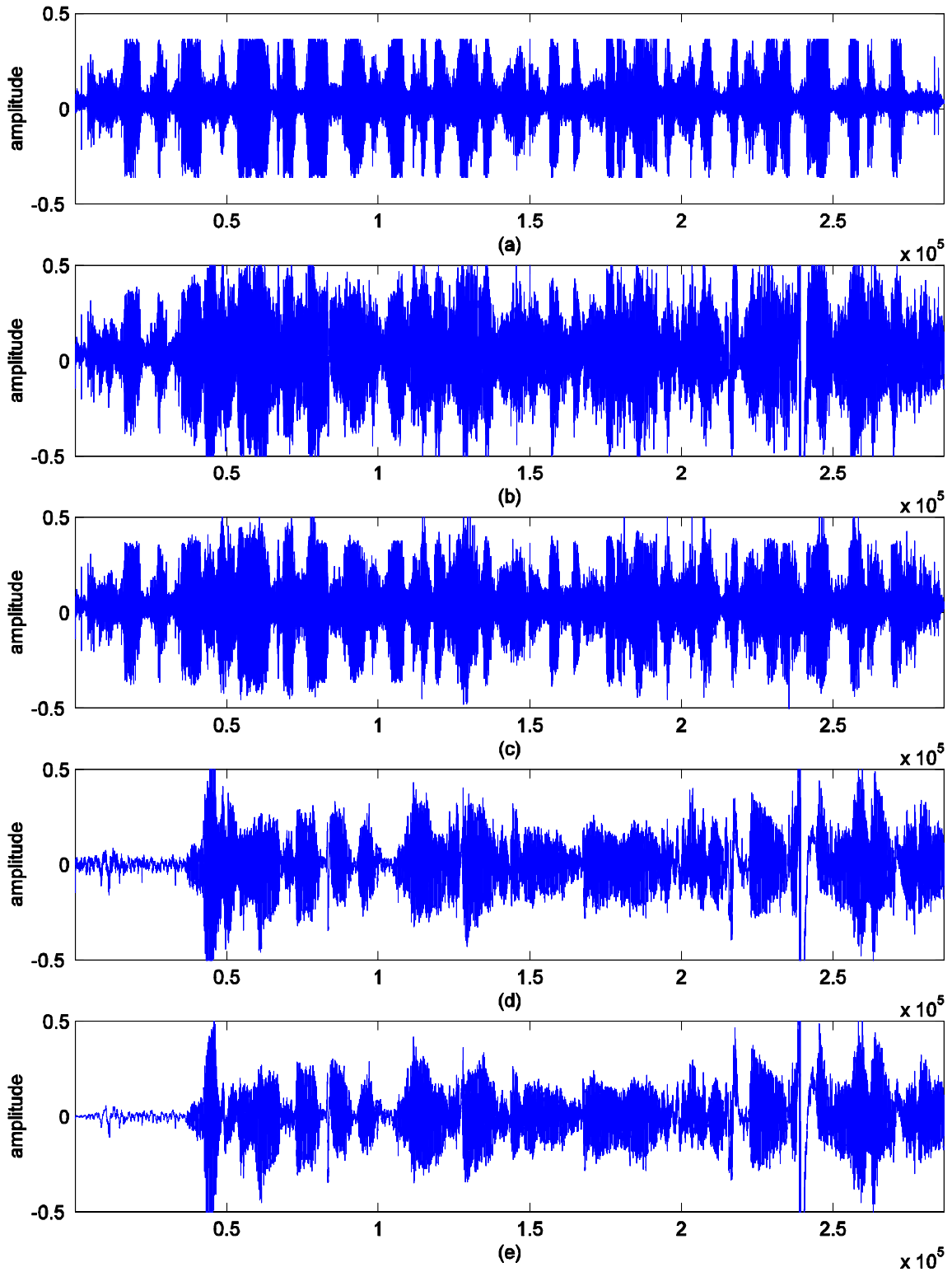

Figure 15. Results for multirate LMS filtering using low-rate observations alone. (a) Original speech signal. (b) Signal plus interference. (c) Filtered signal. (d) Original interference signal. (e) Estimate of interference.

THIS PAGE INTENTIONALLY LEFT BLANK

IV. CONCLUSIONS AND RECOMMENDATIONS

A. CONCLUSIONS

This work developed 1) performance results for the multirate optimal filter and multirate LMS adaptive filters, 2) a least squares approach to finding the filter coefficients, and 3) an adaptive form of the filter based on the LMS algorithm. Both of these filters were used to solve an estimation problem in which multiple independent observations of the data were available. This thesis focused on the case of two observation sequences.

The multirate optimal filter is an extension of the Wiener–Hopf optimal filter for a single input sequence. The use of multiple observation sequences resulted in a lower MSE than the basic Wiener–Hopf filter. For this non–adaptive case, the advantage of using both data sequences over one alone, the amount of training data needed, and observations on optimizing the filter coefficients was addressed.

The multirate LMS filter is an adaptive filter based on the LMS algorithm of Widrow and Hoff. For this adaptive case, results for broadband and narrowband interference in an adaptive noise cancellation scenario were given. Results show that both narrowband and broadband interference may be removed using the low–rate observations alone.

1. Optimal Filtering

The performance of the multirate Wiener filter was compared to that of the single–rate Wiener filter. Since the MSE while using the multirate Wiener filter with both observation sequences is consistently lower than that when using either data set alone, an advantage that can be gained when including more than a single observation signal.

The length of training data needed to solve for the filter parameters was investigated. The required length of training data was found to be comparable to that when using either data sequence alone. Specifically, for the multirate case, solving for K

times as many coefficients required a length of training data comparable to that when using either the high or low-rate sequence alone. In other words, the increase in number of parameters does not translate into an extremely large amount of training data.

A parametric representation of the filter impulse response was investigated and seems possible for high orders of the filter, but this was not further pursued.

2. Adaptive Filtering

The multirate LMS adaptive filter was shown to perform well for adaptive filtering in the context of adaptive noise cancellation. The advantage gained from using the filter is the ability to estimate a signal at the full rate using observations taken at a lower sampling rate. In an adaptive noise cancellation scenario, the multirate LMS filter adequately removed (narrowband) sinusoidal and (broadband) voice interference from a recorded speech signal.

B. RECOMMENDATIONS FOR FUTURE WORK

The use of multirate data and multirate systems is an important part of modern digital signal processing. This thesis has investigated one aspect of the problem, namely filtering and estimation, using a statistical approach. A number of specific extensions of this work are possible and would be beneficial.

Finding a parametric representation of the multirate filter impulse response may be possible; however, this would be a final research step prior to implementation. If the signals could be processed to conform to a known model, then an optimization scheme based on the model might be used, as long as it does not add significantly to the computational cost.

Other forms of the optimal filter could be investigated. A recursive least squares (RLS) form would be a good next step since it is an adaptive method based on least squares [6]. Also, investigation of lattice forms for these filters may give valuable insight into the filtering process.

In addition to these specific topics, other work is currently ongoing in Professor Therrien's research groups on other aspects of statistic multirate problems. The future work will include applications to detection and classification as well as two-dimensional (image) signal processing.

THIS PAGE INTENTIONALLY LEFT BLANK

APPENDIX

This appendix discusses how the simulation data for this thesis was generated. All simulations were performed in MATLAB. Details are given for the methods used to generate both the observed and desired signals.

A. GENERATION OF OBSERVED SIGNALS

Figure 16 illustrates how data was generated for all simulations of multirate Wiener–Hopf filtering.

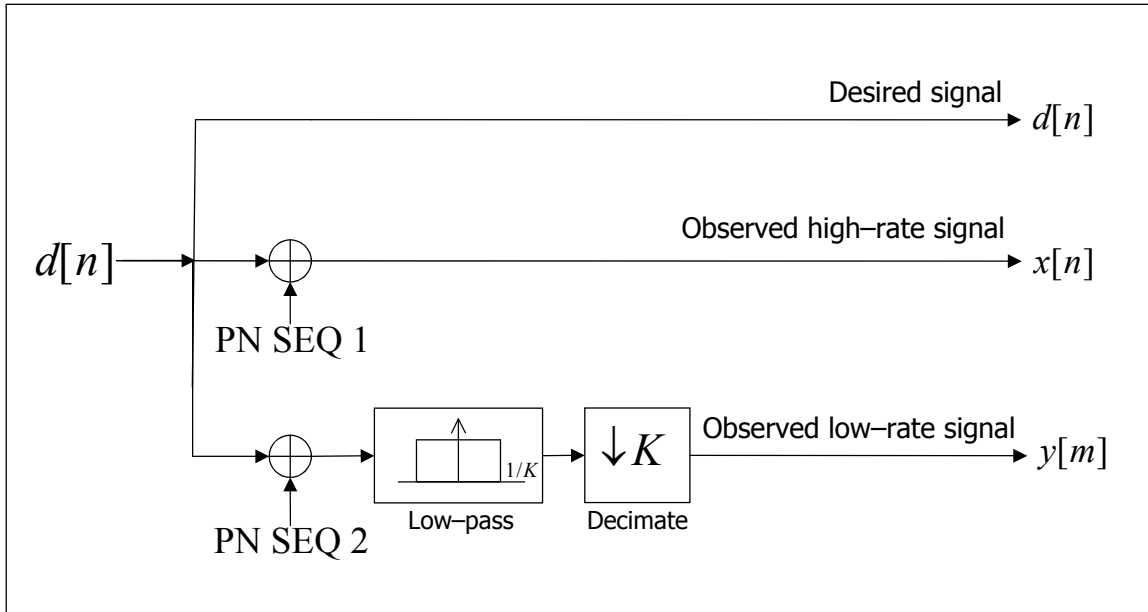

Figure 16. Diagram of data generation process for simulation of multirate Wiener–Hopf filtering.

A desired signal sequence $d(n)$ of length L_d was generated (see Section B below). The power of the desired signal P_d was calculated either from the data or from the theoretical formula (see Section B below). The noisy observations sequences were created as follows: the high-rate observation sequence $x(n)$ was created by adding a pseudorandom Gaussian noise sequence to $d(n)$. This noise sequence is labeled ‘PN SEQ 1’ in Figure 16. The power of the noise sequence was calculated to ensure that $x(n)$

had the desired signal-to-noise ratio of SNR_{high} (see Section C below). The low-rate sequence was generated by adding a second (unique) pseudorandom noise sequence, to the desired signal $d(n)$ (labeled ‘PN SEQ 2’ in Figure 16). The power of the noise sequence was calculated to ensure that the sequence had the desired signal-to-noise ratio of SNR_{low} . The sequence was then sent through a low-pass, anti-aliasing filter with a (normalized) cut-off frequency of $1/K$ (see Section D below). The sequence was then decimated by extracting every K^{th} point to form the low-rate observation sequence $y(m)$.

The reference signals for ANC in the multirate LMS experiments were generated by running the interference through third order FIR filters with randomly selected coefficients. Two separate FIR filters were created, whose coefficients were random numbers uniformly distributed between 1 and 10. Thus, the coefficients were different for each trial of the multirate LMS experiment. The high-rate interference was run through one filter to produce the high-rate reference signal. The same interference was run through the other filter and decimated to produce the low-rate observations.

B. GENERATION OF THE DESIRED SIGNALS

The desired signals for this thesis were the AR, FM, and SINE signals, and a recorded speech signal. The AR signal was obtained by sending a pseudorandom noise sequence of variance $\sigma_w = 0.2$ through a single-pole IIR filter with a denominator polynomial of $1 - \rho z^{-1}$ where $\rho = 0.95$ with a sampling rate of 1 Hz. The theoretical power of this signal is $P_{AR} = \rho^0 \left[\sigma_w^2 / (1 - |\rho|^2) \right]$ [6]. The FM signal was generated from the equation $A \cos(2\pi 0.04t + \cos(0.3t))$ where $A = 10$ with a sampling rate of 1 Hz. The theoretical power of this signal is $P_{FM} = A^2/2$. The SINE signal was generated from the equation $B \cos(2\pi 0.1t)$ with $B = \sqrt{100}$ with a sampling rate of 3.33 Hz. The theoretical power of this signal is $P_{SINE} = B^2/2$. The speech signal was sampled at 44.1 kHz and imported into MATLAB in .WAV format using the `wavread` function. After

processing, all relevant signals were saved in .WAV format using the `wavwrite` function.

C. CALCULATION OF THE SIGNAL-TO-NOISE RATIO

The following logic and procedure was used to produce signals at the desired SNR for these experiments. The SNR in dB for any signal is

$$SNR_{dB} = 10 \log_{10} \left(\frac{P_{signal}}{P_{noise}} \right), \quad (30)$$

where the power of any signal φ is given by

$$P_{\varphi} = \frac{1}{N} \sum_{n=0}^{N-1} |\varphi[n]|^2. \quad (31)$$

For a Gaussian-distributed (normal) noise sequence, the power of the noise sequence is its variance.

A pseudorandom noise sequence was generated using the `randn` function in MATLAB. The function produces a sequence of numbers with a distribution that is *approximately* distributed as $N(0,1)$, i.e., normally distributed with mean zero and variance one. If the desired SNR is SNR_{dB} and the signal power is P_{signal} then the desired variance of the noise is $\sigma_{noise}^2 = P_{signal} / 10^{(SNR_{dB}/10)}$. The noise sequence $N[n]$ from the `randn` function was multiplied by the desired standard deviation to produce a noise sequence with the correct power

$$\eta[n] = \left(\sqrt{\sigma_{noise}^2} \right) N[n]. \quad (32)$$

In order to reproduce results, the seed of the normal random number generator was specified. The two seeds used in these experiments were [362436069; 521288629] for the high-rate data, and [2683551084; 3690929594] for the low-rate data.

D. CALCULATION OF ANTI-ALIASING FILTER COEFFICIENTS

For large sampling rate ratios, the anti-aliasing filter must have a sharp cutoff in order to prevent attenuation of important signal information. With this motivation, the anti-aliasing filter was designed so that the transition bandwidth Δf is always 10 percent of the passband width f_{pass} . The filter was designed for a positive frequency spectrum from 0 to 1 (normalized). Using these constraints, an FIR filter was designed using the Remez exchange algorithm in MATLAB. The parameters were: the (normalized) stopband frequency f_{stop} was $1/K$, the (normalized) passband frequency f_{pass} was $(0.9)f_{stop}$, the passband ripple was 1 dB, and the stopband attenuation was 100 dB. Figures 17 and 18 list the coefficients of the FIR antialiasing filters $F[n]$ used in this thesis (for $K = 3$ and $K = 10$), for those who wish to reproduce the results herein. The filter output is given by

$$y[n] = \sum_{i=0}^{N-1} F[i]x[n-i]. \quad (33)$$

F(0) = -7.98609E-05	F(48) = -0.006759099	F(96) = -0.019984998	F(144) = -0.000491479
F(1) = -0.000361205	F(49) = -0.004741643	F(97) = -0.026823485	F(145) = 0.003080646
F(2) = -0.000969318	F(50) = 0.001674979	F(98) = -0.011232695	F(146) = 0.004172252
F(3) = -0.001862713	F(51) = 0.007097811	F(99) = 0.010903051	F(147) = 0.001910078
F(4) = -0.002665558	F(52) = 0.00659168	F(100) = 0.021057542	F(148) = -0.001878063
F(5) = -0.002646625	F(53) = 0.000125037	F(101) = 0.012838921	F(149) = -0.004142419
F(6) = -0.00098967	F(54) = -0.006997402	F(102) = -0.004696612	F(150) = -0.003007156
F(7) = 0.002673482	F(55) = -0.008433678	F(103) = -0.016242938	F(151) = 0.000789397
F(8) = 0.007742083	F(56) = -0.002396799	F(104) = -0.013197333	F(152) = 0.004470372
F(9) = 0.012550675	F(57) = 0.00634433	F(105) = 0.000272142	F(153) = 0.005311545
F(10) = 0.014966007	F(58) = 0.010158306	F(106) = 0.012047163	F(154) = 0.002656322
F(11) = 0.013517386	F(59) = 0.005143869	F(107) = 0.012709784	F(155) = -0.001593048
F(12) = 0.00843905	F(60) = -0.005014016	F(108) = 0.002871927	F(156) = -0.004283003
F(13) = 0.001871753	F(61) = -0.011632244	F(109) = -0.008357338	F(157) = -0.003120291
F(14) = -0.003120291	F(62) = -0.008357338	F(110) = -0.011632244	F(158) = 0.001871753
F(15) = -0.004283003	F(63) = 0.002871927	F(111) = -0.005014016	F(159) = 0.00843905
F(16) = -0.001593048	F(64) = 0.012709784	F(112) = 0.005143869	F(160) = 0.013517386
F(17) = 0.002656322	F(65) = 0.012047163	F(113) = 0.010158306	F(161) = 0.014966007
F(18) = 0.005311545	F(66) = 0.000272142	F(114) = 0.00634433	F(162) = 0.012550675
F(19) = 0.004470372	F(67) = -0.013197333	F(115) = -0.002396799	F(163) = 0.007742083
F(20) = 0.000789397	F(68) = -0.016242938	F(116) = -0.008433678	F(164) = 0.002673482
F(21) = -0.003007156	F(69) = -0.004696612	F(117) = -0.006997402	F(165) = -0.00098967
F(22) = -0.004142419	F(70) = 0.012838921	F(118) = 0.000125037	F(166) = -0.002646625
F(23) = -0.001878063	F(71) = 0.021057542	F(119) = 0.00659168	F(167) = -0.002665558
F(24) = 0.001910078	F(72) = 0.010903051	F(120) = 0.007097811	F(168) = -0.001862713
F(25) = 0.004172252	F(73) = -0.011232695	F(121) = 0.001674979	F(169) = -0.000969318
F(26) = 0.003080646	F(74) = -0.026823485	F(122) = -0.004741643	F(170) = -0.000361205
F(27) = -0.000491479	F(75) = -0.019984998	F(123) = -0.006759099	F(171) = -7.98609E-05
F(28) = -0.003631442	F(76) = 0.007554848	F(124) = -0.003019216	
F(29) = -0.003731813	F(77) = 0.034455551	F(125) = 0.00296977	
F(30) = -0.000658263	F(78) = 0.034794005	F(126) = 0.006081272	
F(31) = 0.003063166	F(79) = 0.000359361	F(127) = 0.003925625	
F(32) = 0.004281348	F(80) = -0.047179596	F(128) = -0.001359179	
F(33) = 0.001866711	F(81) = -0.066046209	F(129) = -0.005180696	
F(34) = -0.002242833	F(82) = -0.022086413	F(130) = -0.004454695	
F(35) = -0.004567326	F(83) = 0.084055579	F(131) = -6.1619E-05	
F(36) = -0.003009748	F(84) = 0.210619348	F(132) = 0.00412996	
F(37) = 0.001259717	F(85) = 0.29616933	F(133) = 0.004646492	
F(38) = 0.004646492	F(86) = 0.29616933	F(134) = 0.001259717	
F(39) = 0.00412996	F(87) = 0.210619348	F(135) = -0.003009748	
F(40) = -6.1619E-05	F(88) = 0.084055579	F(136) = -0.004567326	
F(41) = -0.004454695	F(89) = -0.022086413	F(137) = -0.002242833	
F(42) = -0.005180696	F(90) = -0.066046209	F(138) = 0.001866711	
F(43) = -0.001359179	F(91) = -0.047179596	F(139) = 0.004281348	
F(44) = 0.003925625	F(92) = 0.000359361	F(140) = 0.003063166	
F(45) = 0.006081272	F(93) = 0.034794005	F(141) = -0.000658263	
F(46) = 0.00296977	F(94) = 0.034455551	F(142) = -0.003731813	
F(47) = -0.003019216	F(95) = 0.007554848	F(143) = -0.003631442	

Figure 17. Listing of Antialiasing Filter Coefficients (for $N = 172$ and $K = 3$).

F(0) = -1.05419E-05	F(48) = -0.002042278	F(96) = -0.0011838	F(144) = 0.00018565
F(1) = -1.50752E-05	F(49) = -0.001943538	F(97) = -0.000983982	F(145) = 0.000682242
F(2) = -2.48133E-05	F(50) = -0.001731552	F(98) = -0.000704219	F(146) = 0.001131282
F(3) = -3.75925E-05	F(51) = -0.001421941	F(99) = -0.000366504	F(147) = 0.001494268
F(4) = -5.33876E-05	F(52) = -0.001035706	F(100) = 2.38063E-06	F(148) = 0.001739112
F(5) = -7.18891E-05	F(53) = -0.000598062	F(101) = 0.000372948	F(149) = 0.001842947
F(6) = -9.23109E-05	F(54) = -0.000136994	F(102) = 0.000715333	F(150) = 0.001794228
F(7) = -0.000113329	F(55) = 0.000318405	F(103) = 0.001001672	F(151) = 0.001593929
F(8) = -0.000133018	F(56) = 0.00073969	F(104) = 0.001208359	F(152) = 0.001255721
F(9) = -0.000148802	F(57) = 0.001100825	F(105) = 0.001317985	F(153) = 0.000805102
F(10) = -0.000157442	F(58) = 0.001379813	F(106) = 0.001320806	F(154) = 0.00027751
F(11) = -0.000155078	F(59) = 0.001560107	F(107) = 0.001215613	F(155) = -0.00028442
F(12) = -0.000137334	F(60) = 0.001631677	F(108) = 0.001009935	F(156) = -0.000834273
F(13) = -9.94761E-05	F(61) = 0.001591677	F(109) = 0.000719533	F(157) = -0.00132565
F(14) = -3.66224E-05	F(62) = 0.001444645	F(110) = 0.000367229	F(158) = -0.001716051
F(15) = 5.59829E-05	F(63) = 0.001202208	F(111) = -1.88572E-05	F(159) = -0.001970515
F(16) = 0.000182649	F(64) = 0.00088232	F(112) = -0.000407517	F(160) = -0.002064715
F(17) = 0.000346882	F(65) = 0.00050806	F(113) = -0.000766952	F(161) = -0.001987226
F(18) = 0.000551021	F(66) = 0.000106065	F(114) = -0.001067351	F(162) = -0.001740767
F(19) = 0.000795879	F(67) = -0.000295289	F(115) = -0.001283346	F(163) = -0.001342298
F(20) = 0.00108042	F(68) = -0.000667841	F(116) = -0.001396146	F(164) = -0.000821908
F(21) = 0.001401494	F(69) = -0.000985613	F(117) = -0.001395163	F(165) = -0.000220603
F(22) = 0.001753655	F(70) = -0.001226625	F(118) = -0.001278998	F(166) = 0.000412893
F(23) = 0.002129101	F(71) = -0.001374458	F(119) = -0.00105569	F(167) = 0.001026035
F(24) = 0.00251774	F(72) = -0.001419424	F(120) = -0.000742202	F(168) = 0.001566783
F(25) = 0.002907405	F(73) = -0.001359274	F(121) = -0.000363162	F(169) = 0.001987969
F(26) = 0.003284214	F(74) = -0.001199369	F(122) = 5.10378E-05	F(170) = 0.002251373
F(27) = 0.003633083	F(75) = -0.000952311	F(123) = 0.000466647	F(171) = 0.002331136
F(28) = 0.003938362	F(76) = -0.00063704	F(124) = 0.000849283	F(172) = 0.002216221
F(29) = 0.004184596	F(77) = -0.000277461	F(125) = 0.001166747	F(173) = 0.001911688
F(30) = 0.004357341	F(78) = 9.92925E-05	F(126) = 0.001391717	F(174) = 0.001438661
F(31) = 0.004444025	F(79) = 0.000464864	F(127) = 0.001504078	F(175) = 0.000832934
F(32) = 0.004434777	F(80) = 0.000791768	F(128) = 0.001492708	F(176) = 0.000142324
F(33) = 0.004323182	F(81) = 0.001055448	F(129) = 0.001356546	F(177) = -0.000577052
F(34) = 0.004106925	F(82) = 0.001236123	F(130) = 0.001104852	F(178) = -0.001265281
F(35) = 0.003788239	F(83) = 0.001320296	F(131) = 0.000756627	F(179) = -0.0018636
F(36) = 0.003374144	F(84) = 0.001301803	F(132) = 0.000339207	F(180) = -0.002319352
F(37) = 0.002876422	F(85) = 0.00118231	F(133) = -0.000113849	F(181) = -0.002590561
F(38) = 0.002311326	F(86) = 0.000971224	F(134) = -0.000565429	F(182) = -0.00264973
F(39) = 0.001699009	F(87) = 0.000685014	F(135) = -0.00097788	F(183) = -0.002486511
F(40) = 0.001062694	F(88) = 0.000345984	F(136) = -0.001316119	F(184) = -0.002109012
F(41) = 0.000427609	F(89) = -1.9413E-05	F(137) = -0.001550598	F(185) = -0.001543587
F(42) = -0.000180249	F(90) = -0.00038259	F(138) = -0.001659856	F(186) = -0.000833088
F(43) = -0.000735468	F(91) = -0.000715033	F(139) = -0.001632456	F(187) = -3.36958E-05
F(44) = -0.00121462	F(92) = -0.000990513	F(140) = -0.001468132	F(188) = 0.000789459
F(45) = -0.0015976	F(93) = -0.001187154	F(141) = -0.001178018	F(189) = 0.00156753
F(46) = -0.001868843	F(94) = -0.001289171	F(142) = -0.000783949	F(190) = 0.002233647
F(47) = -0.002018327	F(95) = -0.001288156	F(143) = -0.000316853	F(191) = 0.002728587

Figure 18. Listing of Antialiasing Filter Coefficients (for $N = 570$ and $K = 10$).

F(192) = 0.003005954	F(240) = 0.002379954	F(288) = 0.077289475	F(336) = 0.004092641
F(193) = 0.003036426	F(241) = 0.000425134	F(289) = 0.068253626	F(337) = 0.002635803
F(194) = 0.002810683	F(242) = -0.001663526	F(290) = 0.057827931	F(338) = 0.001021788
F(195) = 0.002340735	F(243) = -0.003715678	F(291) = 0.046514503	F(339) = -0.000611768
F(196) = 0.001659503	F(244) = -0.005555448	F(292) = 0.034845205	F(340) = -0.002131099
F(197) = 0.000818627	F(245) = -0.007015673	F(293) = 0.023350962	F(341) = -0.003416894
F(198) = -0.000115352	F(246) = -0.007952108	F(294) = 0.012531739	F(342) = -0.004373324
F(199) = -0.001066159	F(247) = -0.008256471	F(295) = 0.002829064	F(343) = -0.00493486
F(200) = -0.001953928	F(248) = -0.007867222	F(296) = -0.005397213	F(344) = -0.005070423
F(201) = -0.002701808	F(249) = -0.00677712	F(297) = -0.011886527	F(345) = -0.004784619
F(202) = -0.003242509	F(250) = -0.005036805	F(298) = -0.01648858	F(346) = -0.004116078
F(203) = -0.003524236	F(251) = -0.002753927	F(299) = -0.019167165	F(347) = -0.003133118
F(204) = -0.003515494	F(252) = -8.7681E-05	F(300) = -0.019996769	F(348) = -0.001927178
F(205) = -0.003208334	F(253) = 0.002761048	F(301) = -0.019152406	F(349) = -0.000604618
F(206) = -0.002619723	F(254) = 0.005563386	F(302) = -0.016893524	F(350) = 0.000722394
F(207) = -0.001790866	F(255) = 0.008079143	F(303) = -0.013543247	F(351) = 0.001945165
F(208) = -0.000784476	F(256) = 0.010075328	F(304) = -0.009464469	F(352) = 0.002967161
F(209) = 0.000319836	F(257) = 0.011345184	F(305) = -0.005034487	F(353) = 0.003711427
F(210) = 0.001431725	F(258) = 0.011726323	F(306) = -0.000619917	F(354) = 0.004126182
F(211) = 0.002457371	F(259) = 0.011116561	F(307) = 0.003446444	F(355) = 0.004188198
F(212) = 0.003307246	F(260) = 0.009486153	F(308) = 0.00688534	F(356) = 0.003903767
F(213) = 0.003903767	F(261) = 0.00688534	F(309) = 0.009486153	F(357) = 0.003307246
F(214) = 0.004188198	F(262) = 0.003446444	F(310) = 0.011116561	F(358) = 0.002457371
F(215) = 0.004126182	F(263) = -0.000619917	F(311) = 0.011726323	F(359) = 0.001431725
F(216) = 0.003711427	F(264) = -0.005034487	F(312) = 0.011345184	F(360) = 0.000319836
F(217) = 0.002967161	F(265) = -0.009464469	F(313) = 0.010075328	F(361) = -0.000784476
F(218) = 0.001945165	F(266) = -0.013543247	F(314) = 0.008079143	F(362) = -0.001790866
F(219) = 0.000722394	F(267) = -0.016893524	F(315) = 0.005563386	F(363) = -0.002619723
F(220) = -0.000604618	F(268) = -0.019152406	F(316) = 0.002761048	F(364) = -0.003208334
F(221) = -0.001927178	F(269) = -0.019996769	F(317) = -8.7681E-05	F(365) = -0.003515494
F(222) = -0.003133118	F(270) = -0.019167165	F(318) = -0.002753927	F(366) = -0.003524236
F(223) = -0.004116078	F(271) = -0.01648858	F(319) = -0.005036805	F(367) = -0.003242509
F(224) = -0.004784619	F(272) = -0.011886527	F(320) = -0.00677712	F(368) = -0.002701808
F(225) = -0.005070423	F(273) = -0.005397213	F(321) = -0.007867222	F(369) = -0.001953928
F(226) = -0.00493486	F(274) = 0.002829064	F(322) = -0.008256471	F(370) = -0.001066159
F(227) = -0.004373324	F(275) = 0.012531739	F(323) = -0.007952108	F(371) = -0.000115352
F(228) = -0.003416894	F(276) = 0.023350962	F(324) = -0.007015673	F(372) = 0.000818627
F(229) = -0.002131099	F(277) = 0.034845205	F(325) = -0.005555448	F(373) = 0.001659503
F(230) = -0.000611768	F(278) = 0.046514503	F(326) = -0.003715678	F(374) = 0.002340735
F(231) = 0.001021788	F(279) = 0.057827931	F(327) = -0.001663526	F(375) = 0.002810683
F(232) = 0.002635803	F(280) = 0.068253626	F(328) = 0.000425134	F(376) = 0.003036426
F(233) = 0.004092641	F(281) = 0.077289475	F(329) = 0.002379954	F(377) = 0.003005954
F(234) = 0.005262115	F(282) = 0.08449249	F(330) = 0.004049273	F(378) = 0.002728587
F(235) = 0.006032647	F(283) = 0.089505004	F(331) = 0.005311247	F(379) = 0.002233647
F(236) = 0.006321349	F(284) = 0.092075965	F(332) = 0.006082152	F(380) = 0.00156753
F(237) = 0.006082152	F(285) = 0.092075965	F(333) = 0.006321349	F(381) = 0.000789459
F(238) = 0.005311247	F(286) = 0.089505004	F(334) = 0.006032647	F(382) = -3.36958E-05
F(239) = 0.004049273	F(287) = 0.08449249	F(335) = 0.005262115	F(383) = -0.000833088

Figure 18. (continued).

F(384) = -0.001543587	F(432) = -0.001550598	F(480) = -1.9413E-05	F(528) = 0.000427609
F(385) = -0.002109012	F(433) = -0.001316119	F(481) = 0.000345984	F(529) = 0.001062694
F(386) = -0.002486511	F(434) = -0.00097788	F(482) = 0.000685014	F(530) = 0.001699009
F(387) = -0.00264973	F(435) = -0.000565429	F(483) = 0.000971224	F(531) = 0.002311326
F(388) = -0.002590561	F(436) = -0.000113849	F(484) = 0.00118231	F(532) = 0.002876422
F(389) = -0.002319352	F(437) = 0.000339207	F(485) = 0.001301803	F(533) = 0.003374144
F(390) = -0.0018636	F(438) = 0.000756627	F(486) = 0.001320296	F(534) = 0.003788239
F(391) = -0.001265281	F(439) = 0.001104852	F(487) = 0.001236123	F(535) = 0.004106925
F(392) = -0.000577052	F(440) = 0.001356546	F(488) = 0.001055448	F(536) = 0.004323182
F(393) = 0.000142324	F(441) = 0.001492708	F(489) = 0.000791768	F(537) = 0.004434777
F(394) = 0.000832934	F(442) = 0.001504078	F(490) = 0.000464864	F(538) = 0.004444025
F(395) = 0.001438661	F(443) = 0.001391717	F(491) = 9.92925E-05	F(539) = 0.004357341
F(396) = 0.001911688	F(444) = 0.001166747	F(492) = -0.000277461	F(540) = 0.004184596
F(397) = 0.002216221	F(445) = 0.000849283	F(493) = -0.00063704	F(541) = 0.003938362
F(398) = 0.002331136	F(446) = 0.000466647	F(494) = -0.000952311	F(542) = 0.003633083
F(399) = 0.002251373	F(447) = 5.10378E-05	F(495) = -0.001199369	F(543) = 0.003284214
F(400) = 0.001987969	F(448) = -0.000363162	F(496) = -0.001359274	F(544) = 0.002907405
F(401) = 0.001566783	F(449) = -0.000742202	F(497) = -0.001419424	F(545) = 0.00251774
F(402) = 0.001026035	F(450) = -0.00105569	F(498) = -0.001374458	F(546) = 0.002129101
F(403) = 0.000412893	F(451) = -0.001278998	F(499) = -0.001226625	F(547) = 0.001753655
F(404) = -0.000220603	F(452) = -0.001395163	F(500) = -0.000985613	F(548) = 0.001401494
F(405) = -0.000821908	F(453) = -0.001396146	F(501) = -0.000667841	F(549) = 0.00108042
F(406) = -0.001342298	F(454) = -0.001283346	F(502) = -0.000295289	F(550) = 0.000795879
F(407) = -0.001740767	F(455) = -0.001067351	F(503) = 0.000106065	F(551) = 0.000551021
F(408) = -0.001987226	F(456) = -0.000766952	F(504) = 0.00050806	F(552) = 0.000346882
F(409) = -0.002064715	F(457) = -0.000407517	F(505) = 0.00088232	F(553) = 0.000182649
F(410) = -0.001970515	F(458) = -1.88572E-05	F(506) = 0.001202208	F(554) = 5.59829E-05
F(411) = -0.001716051	F(459) = 0.000367229	F(507) = 0.001444645	F(555) = -3.66224E-05
F(412) = -0.00132565	F(460) = 0.000719533	F(508) = 0.001591677	F(556) = -9.94761E-05
F(413) = -0.000834273	F(461) = 0.001009935	F(509) = 0.001631677	F(557) = -0.000137334
F(414) = -0.00028442	F(462) = 0.001215613	F(510) = 0.001560107	F(558) = -0.000155078
F(415) = 0.00027751	F(463) = 0.001320806	F(511) = 0.001379813	F(559) = -0.000157442
F(416) = 0.000805102	F(464) = 0.001317985	F(512) = 0.001100825	F(560) = -0.000148802
F(417) = 0.001255721	F(465) = 0.001208359	F(513) = 0.00073969	F(561) = -0.000133018
F(418) = 0.001593929	F(466) = 0.001001672	F(514) = 0.000318405	F(562) = -0.000113329
F(419) = 0.001794228	F(467) = 0.000715333	F(515) = -0.000136994	F(563) = -9.23109E-05
F(420) = 0.001842947	F(468) = 0.000372948	F(516) = -0.000598062	F(564) = -7.18891E-05
F(421) = 0.001739112	F(469) = 2.38063E-06	F(517) = -0.001035706	F(565) = -5.33876E-05
F(422) = 0.001494268	F(470) = -0.000366504	F(518) = -0.001421941	F(566) = -3.75925E-05
F(423) = 0.001131282	F(471) = -0.000704219	F(519) = -0.001731552	F(567) = -2.48133E-05
F(424) = 0.000682242	F(472) = -0.000983982	F(520) = -0.001943538	F(568) = -1.50752E-05
F(425) = 0.00018565	F(473) = -0.0011838	F(521) = -0.002042278	F(569) = -1.05419E-05
F(426) = -0.000316853	F(474) = -0.001288156	F(522) = -0.002018327	
F(427) = -0.000783949	F(475) = -0.001289171	F(523) = -0.001868843	
F(428) = -0.001178018	F(476) = -0.001187154	F(524) = -0.0015976	
F(429) = -0.001468132	F(477) = -0.000990513	F(525) = -0.00121462	
F(430) = -0.001632456	F(478) = -0.000715033	F(526) = -0.000735468	
F(431) = -0.001659856	F(479) = -0.00038259	F(527) = -0.000180249	

Figure 18. (continued).

LIST OF REFERENCES

- [1] Sophocles J. Orfanidis, *Introduction to Signal Processing*, Prentice Hall, Inc., Upper Saddle River, New Jersey, 1996.
- [2] John G. Proakis and Dimitris G. Manolakis, *Digital Signal Processing*, Prentice Hall, Inc., Upper Saddle River, New Jersey, 1996.
- [3] Gregory W. Wornell, "Emerging Applications of Multirate Signal Processing and Wavelets in Digital Communications," *Proceedings of the IEEE*, Vol. 84, No. 4, pp. 586-603. April 1996.
- [4] Dimitrios Koupatsiaris, "Analysis of Multirate Random Signals," Master's thesis, Naval Postgraduate School, Monterey, California, 2000.
- [5] Charles W. Therrien, "Issues in Multirate Statistical Signal Processing," *Proc. of 35th Asilomar Conf. On Circuits, Systems, and Computers*. November 2001, pp. 573-576. (Pacific Grove, CA).
- [6] Charles W. Therrien, *Discrete Random Signals and Statistical Signal Processing*, Prentice Hall, Inc., Upper Saddle River, New Jersey, 1992.
- [7] Simon Haykin, *Adaptive Filter Theory*, Prentice Hall, Inc., 4th Edition, Upper Saddle River, New Jersey, 2002.
- [8] Thomas L. Boullion and Patrick L. Odell, *Generalized Inverse Matrices*, John Wiley and Sons, 1971.
- [9] Bernard Widrow, Michael Lehr, Françoise Beaufays, Eric Wan, and Michel Bilello, "Learning Algorithms for Adaptive Signal Processing and Control," *IEEE Conference on Neural Networks*, Vol. 1, pp. 1-8, 1993.
- [10] R. Cristi, D.A. Koupatsiaris, and C. W. Therrien, "Multirate Filtering and Estimation: The Multirate Wiener Filter," *Proceedings of the 34th Asilomar Conference on Circuits, Systems, and Computers*. November 2000, pp. 450-454. (Pacific Grove, CA).
- [11] Charles W. Therrien and Anthony H. Hawes, "Least Squares Optimal Filtering with Multirate Observations," *Proceedings of the 36th Asilomar Conference on Circuits, Systems, and Computers*. November 2002, pp. 1782-1786. (Pacific Grove, CA).
- [12] O. Macchi, *Adaptive Processing: the Least Mean Squares Approach*, John Wiley and Sons, 1995.

THIS PAGE INTENTIONALLY LEFT BLANK

INITIAL DISTRIBUTION LIST

1. Defense Technical Information Center
Ft. Belvoir, Virginia
2. Dudley Knox Library
Naval Postgraduate School
Monterey, California
3. Prof. Charles W. Therrien, Code EC/Ti
Department of Electrical and Computer Engineering
Naval Postgraduate School
Monterey, California
4. Prof. Roberto Cristi, Code EC/Cx
Department of Electrical and Computer Engineering
Naval Postgraduate School
Monterey, California
5. Prof. John Powers
Chairman, Department of Electrical and Computer Engineering
Naval Postgraduate School
Monterey, California
6. Anthony H. Hawes
U.S. Coast Guard
Washington, District of Columbia.
7. CAPT Richard Hartnett
Section Chief, Electrical Engineering
Department of Engineering
United States Coast Guard Academy
New London, Connecticut
8. CDR Dean Bruckner
Commandant (G-SRF)
U.S. Coast Guard
Washington, District of Columbia
9. CDR John Knox
Commandant (G-SRF)
U.S. Coast Guard
Washington, District of Columbia