

Naval Submarine Medical Research Laboratory

NSMRL Report 1164

10 December 1990



IDENTIFICATION OF COLOR CODED TARGET LINES OF DIFFERENT ORIENTATIONS ON CRT SCREENS

S. M. Luria

David F. Neri
Naval Aerospace Medical Research Laboratory

Matthew J. Shim

Released by:
R. G. Walter, CAPT, DC, USN
Commanding Officer
Naval Submarine Medical Research Laboratory

20031216 193

Approved for public release; distribution unlimited

IDENTIFICATION OF COLOR CODED TARGET LINES OF DIFFERENT
ORIENTATIONS ON CRT SCREENS

S. M. Luria

David F. Neri
Naval Aerospace Medical Research Laboratory

Matthew J. Shim

NAVAL SUBMARINE MEDICAL RESEARCH LABORATORY

NSMRL REPORT 1164

NAVAL MEDICAL RESEARCH AND DEVELOPMENT COMMAND
RESEARCH WORK UNIT 65856N-M0100.001-5003

Approved and released by

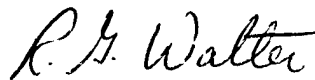

R. G. WALTER CAPT, DC, USN

Commanding Officer

NavSubMedRschLab

Approved for public release; distribution unlimited

SUMMARY PAGE

THE PROBLEM

To determine if the ability to match the color of a target line presented on a CRT varies with its orientation.

THE FINDINGS

When the target tracks were one pixel wide, performance was significantly worse for diagonal tracks than for horizontal or vertical tracks. When the target tracks were two pixels wide, there were no significant differences with orientation. Performance was not affected by the presence of colored distractor lines.

APPLICATION

The use of color coding with target tracks only one pixel wide will result in more errors of color matching for diagonal lines. Designers of color-coded displays should be aware that extensive color coding should be used only with target tracks two or more pixels wide.

ADMINISTRATIVE INFORMATION

This investigation was conducted under Naval Medical Research and Development Command Research Work Unit 65856N-M0100.001-5003. It was submitted for review on 10 October 1990, approved for publication on 10 December 1990, and designated Naval Submarine Medical Research Report 1164.

Abstract

Current passive broadband sonar "waterfall" displays are monochromatic, but color may be added in the future. One possible use of color would be to have the operator assign different colors to the different target tracks. The speed and accuracy of matching a colored target line on a CRT to a standard set of colors was measured as a function of the orientation of the target line. With lines one pixel wide, performance was significantly worse for diagonal than horizontal or vertical lines. There were no significant differences when the width of the line was doubled. Performance was not affected by the presence of colored distractor lines.

INTRODUCTION

Current passive broadband sonar "waterfall" displays are monochromatic, but it is possible that color may be added in the future. One possible use of color would be to have the operator assign different colors to the different target tracks.

We assume that in using color, alphanumeric information about the targets would be displayed in the same color as the relevant target track, and the operator would want to be able to associate as quickly and accurately as possible a given track with its alphanumerics. We have examined the question of how many colors an operator could recognize or recall without undue confusion (Luria, Neri, & Jacobsen, 1986; Jacobsen & Neri, 1985; Jacobsen, 1985). In the initial study, only one target track was displayed (Luria, Neri, & Jacobsen, 1986); subsequently, several target tracks were displayed to see if they detracted from the ability to focus on the track of primary interest (Luria, Neri, Shim, & Bivenour, 1990).

In these studies, the target track was always a vertical line on the display. On actual sonar displays, however, the target track can appear at various angles and orientations. The question arises, what would be the effect of variations in the target track orientation on performance? In displaying target tracks at different orientations, it was immediately apparent that, despite unchanging "instructions" to the computer, the narrow (one pixel wide) tracks varied in width depending on their orientation. They varied in width depending on the color as well. Even if the width were constant, the color for a narrow stimulus could vary because of the variations in the pixels which happen to be illuminated at different orientations (Cf. Merrifield, 1987). This variability according to both color and orientation appears to be characteristic of shadow-mask CRTs. Would this variability at supra-threshold luminances have a significant effect on the operator's ability to respond accurately and quickly to the different colors?

There is a well known perceptual phenomenon which is related to this problem: the so-called "oblique effect". The threshold visibility of fine lines varies with their orientation; horizontal and vertical lines are more detectable or yield higher visual acuity than oblique lines (Higgins & Stultz, 1948, 1950; Leibowitz, 1953; Ogilvie & Taylor, 1958; Nachmias, 1960; Luria, 1963; Campbell, Kulikowski, & Levinson, 1966; Mitchell, Freeman, & Westheimer, 1967; Pointer & Hess, 1990; Taylor, 1963). This effect, which is quite evident at threshold, declines, however, when the visual stimuli are clearly visible (St. John, Timney, Armstrong, & Szpak, 1987). Moreover, Kelly (1975) has reported that there is no oblique effect for the detection of chromatic stimuli. It is, therefore, not likely to play a part in the present study. Any effects on performance will for the most part be due to the physical variations in the stimuli with changes in orientation. To investigate any such effects, we have repeated our previous experiments with colored lines of different orientations.

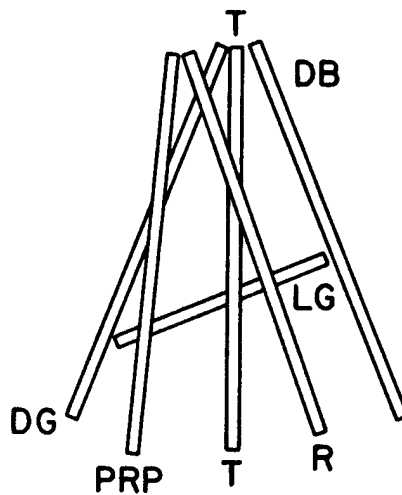
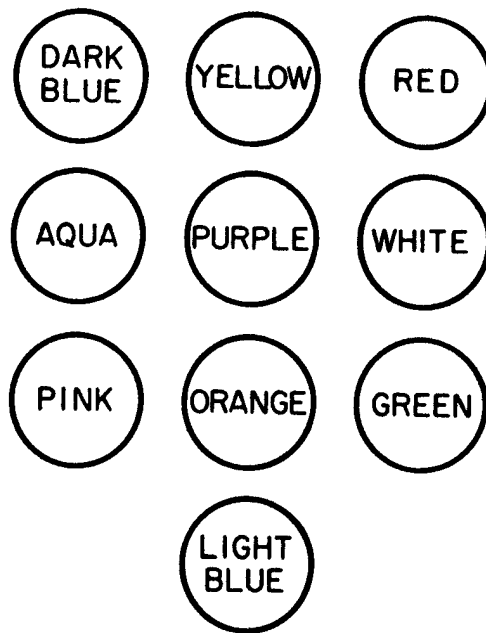

Figure 1. The display. The target line (T), shown here in the vertical position, was presented either alone or with the other five lines colored dark blue (DB), dark green (DG), light green (LG), purple (PRP), and red (R). The target line was also presented in the horizontal position, at 45 deg to the right, and at 45 deg to the left.

METHOD

Subjects

Eight staff members of the laboratory volunteered to participate. All were color normal, according to the Hardy-Rand-Rittler pseudo-isochromatic plates and had 20/20 acuity, with their spectacle corrections, if necessary.

Apparatus

The stimuli were presented on an Advanced Electronics Design, Inc. Color Graphics and Imaging Terminal, Model 1024, under the control of a Digital PDP 11/04 minicomputer. A series of circular stimuli was arranged in the pattern of a telephone pushbutton keypad: a 3x3 matrix plus one additional stimulus centered below these (Figure 1). Each circle was 1 cm in diameter, separated by 0.75 cm from the adjacent stimulus. The total arrangement measured 4.5 cm wide by 6.2 cm high.

A telephone pushbutton response keypad was placed on a table in front of the subject. The arrangement of its 10 keys was identical to that of the circular stimuli on the display.

The circles were of different colors and brightnesses and were always present. The C.I.E. coordinates and luminances were measured with a Photo Research Spectroradiometer, Model PR 703A, and are listed in Table 1 and shown in Figure 2.

TABLE 1

The chromaticity coordinates and luminances
of the colors

Target Color	Chromaticity		Luminance cd/m ²
	x	y	
Dark Blue	.15	.09	2.7
Yellow	.43	.45	42.7
Red	.61	.35	17.8
Aqua	.25	.38	9.8
Purple	.27	.16	2.2
White	.29	.31	44.7
Pink	.37	.35	13.1
Orange	.56	.36	7.0
Green	.30	.52	31.4
Light Blue	.17	.13	12.0

Distractor Color	Chromaticity		Luminance cd/m ²
	x	y	
Dark Blue	.16	.13	2.1
Dark Green	.30	.55	26.4
Light Green	.30	.59	44.1
Purple	.28	.21	5.9
Red	.61	.36	13.8

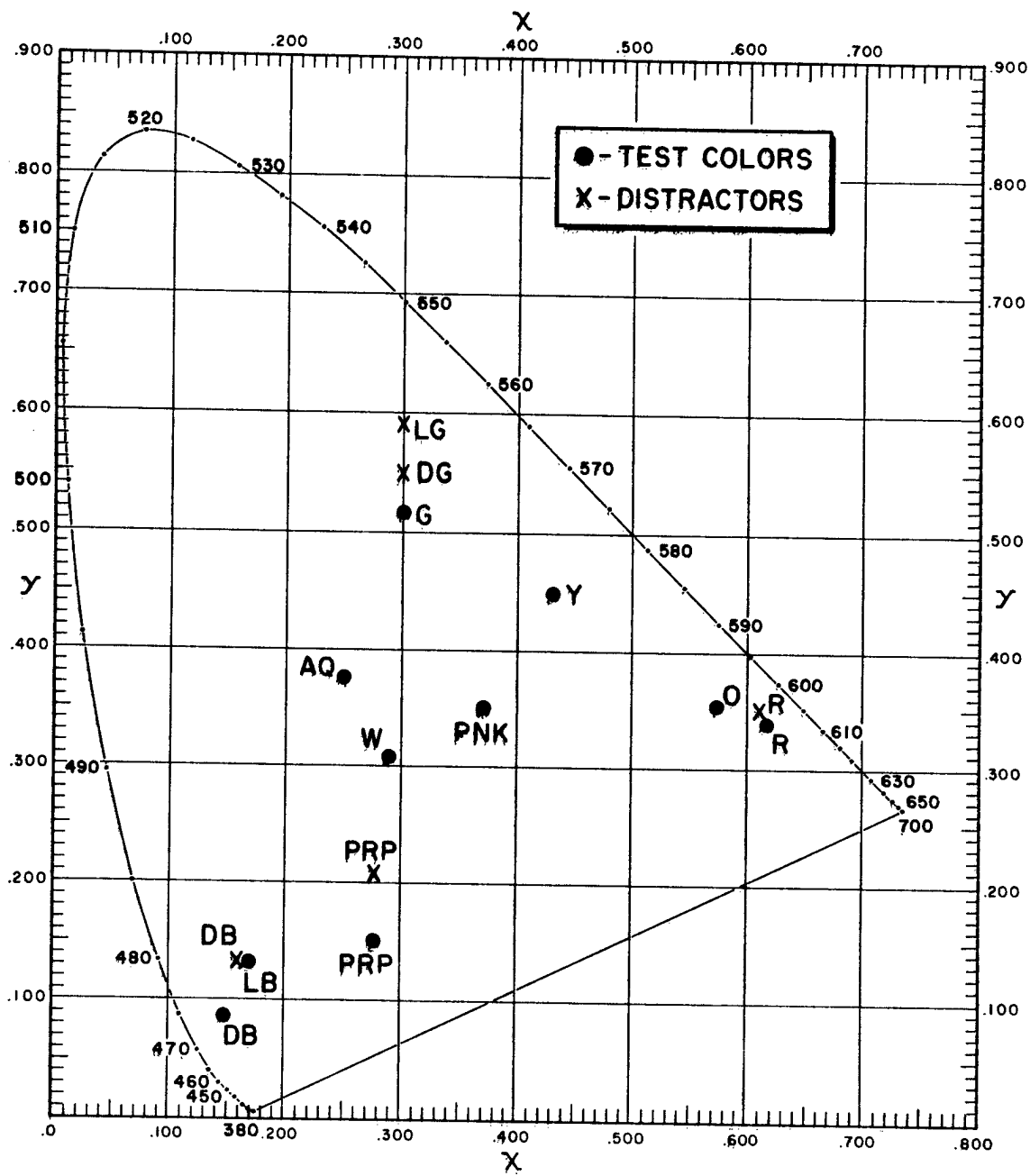

Figure 2. C.I.E. chromaticity coordinates of the stimuli.

The target line was 3 cm long and was presented in one of four orientations: vertical, horizontal, and 45 deg (diagonal right) or 315 deg (diagonal left). Although the computer was instructed to produce a line 1 pixel wide, the actual width of the lines varied about a mean of 1 mm, depending on the color and orientation. The target line was presented in the center of the display with the top of the vertical line 6 cm below the lowest circle or the horizontal line 7.5 cm below the lowest circle. At the viewing distance of about 60 cm, the circular stimuli subtended .95 deg visual angle; the vertical line subtended 2.9 deg visual angle in length and about 0.01 deg visual angle in width.

The target could be presented alone or in the presence of five other lines which were always in the same arrangement (Figure 1). These additional lines (referred to as distractors) were red, dark blue, purple, light green, and dark green (see Table 1).

Procedure

Each subject was first given a series of training runs before starting the experiment. The outlines of the 10 circles were presented in the appropriate color but the circles were unfilled. One second after a warning tone, one of the circles filled with its color. The subject pressed the button on the keypad that corresponded to the position of the filled circle as quickly as possible. The button press caused the circle to return to its original unfilled condition. After a two-second delay, another warning tone sounded, followed by another circle being filled. No color matching was involved. The circles were presented in random order until the subject made 7 correct responses to each circle. One training run thus comprised 70 correct responses and took about three or four minutes. The computer recorded which button had been pushed and the reaction time (RT). Incorrect button pushes were not included in the mean RTs. The training runs continued until the RT had no longer decreased for three runs. The stable mean RTs indicated the times required to respond using each button in the keypad without having to match the colors. The training runs not only gave the subjects practice in responding, but provided them an opportunity to learn the positions of the colors.

During the experiment, the target line appeared one second after a warning tone. It was identical in color to one of the (now filled) circles. The subject matched the line to the correct color as quickly as possible by pressing the corresponding button. Each orientation was presented during the test session. The order of the four orientations was counterbalanced for the eight subjects.

RESULTS

Experiment 1

In the first study, the target line was presented without the distractors. To get the RT for the color matching, the stabilized practice response time for each button was subtracted from the corresponding color matching time for each subject. Table 2 gives the mean RT of the color

matches for each orientation. There were no differences in RT among orientations, but the reaction times to the different colors varied significantly ($F= 14.7, p < .0001$).

TABLE 2

Mean Reaction Times (sec) to the Colors
at the Different Orientations
in Experiment 1

	Horiz	Vert	Diag (R)	Diag (L)
Dark Blue	.54	.48	.62	.55
Yellow	.52	.46	.54	.49
Red	.71	.64	.58	.65
Aqua	.66	.62	.68	.66
Purple	.37	.33	.38	.34
White	.48	.44	.48	.46
Pink	.61	.46	.47	.50
Orange	.59	.77	.58	.61
Green	.60	.66	.59	.59
Lt. Blue	.71	.72	.67	.66
Mean	.58	.56	.56	.55
S.E.M.	.033	.045	.030	.033

The number of matching errors was significantly greater for the diagonal lines than for the horizontal or vertical lines, according to a Friedman non-parametric analysis of variance ($X^2 = 12.6, p < .01$). Table 3 shows the errors for each color at each orientation. It should be noted that because it was obvious that some of the errors were simply motor errors (e.g., pushing button 8 instead of 10 just below it, or matching orange to blue), any errors which occurred no more than twice when summed over the eight subjects were not counted in preparing this table. Thus the smallest number of errors in a cell in Table 3 is three.

It is clear that the same matching errors are made regardless of the target orientation. The only error consistently made to a light blue target is to match it to dark blue; the difference with orientation is that far more errors were made when the target was a diagonal than when it was horizontal or vertical. It was not always the case, however, that the diagonal target always led to increased errors: the dark blue target was erroneously matched to light blue when it was horizontal or vertical but not when it was diagonal. Green was matched to aqua equally when it was diagonal or not.

TABLE 3

Color Matching Errors
at the Different Orientations
in Experiment 1*

Target	Horizontal	Vertical	Diag. (R)	Diag. (L)
Dk. Blue	Lt. Blue (4)	Lt. Blue (8)	-	-
Yellow	-	Pink (4)	Pink (9)	Pink (4)
Red	-	-	Orange (19)	Orange (16)
Aqua	-	Green (9)	Green (13)	Green (16)
Purple	-	-	-	-
White	-	-	-	-
Pink	-	-	-	-
Orange	Red (12)	-	Red (12)	Red (8)
Green	Aqua (4)	-	-	Aqua (3)
Lt. Blue	Dk. Blue (9)	Dk. Blue (13)	Dk. Blue (16)	Dk. Blue (29)
TOTAL	29	34	69	76

* If there were fewer than three errors in a cell summed over the eight subjects, they were not included.

Experiment 2

In an attempt to reduce the orientation effect, the computer was programmed to produce target lines 2 pixels wide. Again there were obvious differences in the apparent width of the lines with changes in orientation and color. We assumed, however, that the color would be more definite under any condition. The same subjects again participated. The orientations were again counterbalanced.

RESULTS

Table 4 presents the RTs to the colors at each orientation. Again the RTs to the different orientations were not significantly different, although the RTs to the different colors once again varied significantly ($p < .0001$). These RTs were appreciably shorter, indicating that the wider target tracks made the matching task easier.

TABLE 4

Mean Reactions Times (sec) to the Colors
for the Different Orientations
in Experiment 2

	Horiz	Vert	Diag (R)	Diag (L)
Dark Blue	.38	.43	.44	.35
Yellow	.31	.35	.25	.34
Red	.41	.40	.51	.43
Aqua	.53	.43	.50	.44
Purple	.16	.17	.18	.16
White	.26	.19	.27	.30
Pink	.33	.29	.32	.33
Orange	.41	.50	.45	.49
Green	.42	.43	.35	.38
Lt. Blue	.38	.51	.52	.55
Mean	.36	.37	.38	.38
S.E.M.	.032	.038	.038	.034

There were now no significant differences in the number of errors for the four orientations according to a Friedman analysis of variance by ranks ($X^2 = 2.43$, $p < .50$). Table 5 shows the breakdown of errors to the different colors as a function of target orientation. Again, those errors which occurred no more than twice when summed over the eight subjects were ignored in this table. Only three matching errors were made with any frequency; light blue was again identified as dark blue; orange was identified as red; aqua was identified as green. These errors were not made systematically with orientation.

TABLE 5

Color Matching Errors
for the Different Orientations
in Experiment 2*

Target	Horizontal	Vertical	Diag. (R)	Diag. (L)
Dk. Blue	-	-	-	-
Yellow	-	-	-	-
Red	-	-	-	Orange (4)
Aqua	-	Green (3)	Green (4)	Green (3)
Purple	-	-	-	-
White	-	-	-	-
Pink	-	-	-	-
Orange	Red (7)	Red (5)	Red (3)	Red (5)
Green	-	-	-	-
Lt. Blue	Dk. Blue (3)	-	Dk. Blue (3)	Dk. Blue (3)
TOTAL	10	8	10	15

* If there were fewer than three errors in a cell summed over the eight subjects, they were ignored.

Experiment 3

Finally, the target line, again two pixels in width, was presented in the presence of the distractors. Again, the same subjects participated.

RESULTS

Table 6 gives the RTs to the colors as a function of orientation. The RTs were not significantly different for the four orientations, according to an analysis of variance. The number of matching errors was not significantly different between orientations, according to a Friedman analysis of variance by ranks ($\chi^2 = 0.71$, $p < .90$) for the various orientations. Table 7 gives the breakdown of errors to the colors at the various orientations; again, those errors occurring no more than twice in a cell were not counted. The errors made were similar to those made in the first two experiments; primarily, light blue was identified as dark blue. The large number of errors for the first diagonal was due to one subject. Since a given color was repeated until ten correct matches had been made, this color was repeatedly presented and repeatedly mismatched by this subject.

TABLE 6

Mean Reaction Times (sec) to the Colors
for the Different Orientations
with the Distractors
in Experiment 3

	Horiz	Vert	Diag (R)	Diag (L)
Dark Blue	.38	.38	.38	.37
Yellow	.26	.21	.22	.26
Red	.39	.38	.47	.55
Aqua	.38	.45	.45	.49
Purple	.16	.29	.25	.26
White	.27	.26	.21	.21
Pink	.26	.32	.32	.26
Orange	.47	.50	.50	.50
Green	.41	.40	.53	.45
Lt. Blue	.51	.47	.49	.54
Mean	.35	.37	.38	.39
S.E.M.	.034	.030	.039	.132

TABLE 7

Color Matching Errors
for the Different Orientations
with the Distractors
in Experiment 3*

Target	Horizontal	Vertical	Diag. (R)	Diag. (L)
Dk. Blue	Lt. Blue (3)	-	-	-
Yellow	-	-	-	-
Red	Orange (5)	-	Orange (8)	-
Aqua	-	-	-	-
Purple	-	-	-	-
White	-	-	-	-
Pink	-	-	-	-
Orange	-	Red (6)	Red (12)	-
Green	-	-	-	-
Lt. Blue	Dk. Blue (7)	Dk. Blue (5)	Dk. Blue (18)	Dk. Blue (5)
TOTAL	15	11	38	5

* If there were fewer than three errors in a cell summed over the eight subjects, they were ignored.

Finally, the RTs were significantly higher in the first experiment than in the other two experiments ($F = 70.20$, $p < .0001$), but they were not significantly different in the second and third experiments ($F = 0.004$, $p < .95$), indicating that the distractors did not impair performance.

The error rate was, as expected, significantly higher in the first experiment according to a Friedman analysis of variance by ranks ($X^2 = 7.00$, $p < .05$).

DISCUSSION

Using this shadow-mask CRT, varying the orientation of the target line altered its width and its apparent color when it was programmed to be only one pixel wide. This resulted from changes in the excitation of the red-green-blue triads as orientation varied, and these changes affected performance with a very thin target line. When, however, the width of the target line was increased to two pixels, the changes in color which resulted from changes in orientation were insignificant. Apparently, if the target line is very narrow, changes in width affect performance; if the target line is two pixels wide, the changes in width do not have a significant effect on performance. It seems reasonable to assume that the same would be true for even wider target tracks. Similarly, Carter and Carter (1988) have reported that colors of symbols subtending less than 30' are less distinct than those that subtend at least one deg. visual angle.

It should be kept in mind that these stimuli were all well above threshold. Performance might be affected much more seriously if very narrow target lines were close to threshold.

These results confirm previous results (Luria, et al., 1990). First, the distractors did not significantly degrade performance, and, second, the results again show very strongly the lack of symmetry or "transitivity" of the matching errors. Although light blue was repeatedly misidentified as dark blue, the reverse occurred much less frequently; similarly, aqua was often confused with green, but not the reverse; and red was confused with orange much more than orange was confused with red.

ACKNOWLEDGMENTS

We thank CAPT Paul Weathersby, MSC, USN for suggesting this study and Ms. Kelly Johnson who collected most of the data.

REFERENCES

- Campbell, F.W., Kulikowski, J.J., & Levinson, J. (1966). The effect of orientation on the visual resolution of gratings. J. Physiol. (London) 187, 427-436.
- Carter, R.C., & Carter, E.C. (1988). Color coding for rapid location of small symbols. COLOR res. and application 13, 226-234.
- Higgins, G.C. & Stultz, K. (1948). Visual acuity as measured with various orientations of a parallel-line test object. J. Opt. Soc. Am. 38, 756-758.
- Higgins, G.C. & Stultz, K. (1950). Variations of visual acuity with various test-object orientations and viewing conditions. J. Opt. Soc. Am. 40, 135-137.
- Jacobsen, A. R. (1985). Effect of set size on time to recall color coded information. NSMRL Rep. 1044.
- Jacobsen, A.R. & Neri, D.F. (1985). Effect of set size on color recognition. NSMRL Rep. 1041.
- Kelly, D.H. (1975). No oblique effect in chromatic pathways. J. Opt. Soc. Am. 65, 1512-1514.
- Leibowitz, H. (1953). Some observations and theory on the variation of visual acuity with the orientation of the test object. J. Opt. Soc. Am. 43, 902-905.
- Luria, S.M. (1963). The effect of body-position on meridional variations in scotopic acuity. Am. J. Psychol. 76, 598-606.
- Luria, S.M., Neri, D.F., & Jacobsen, A.R. (1986). The effects of set size on color matching using CRT displays. Human Factors 29, 49-61.
- Luria, S.M., Neri, D.F., Shim, M.J., & Bivenour, R. (1990). Effect of extraneous color-coded targets on identification of targets on CRT displays. NSMRL Rep. 1154.
- Merrifield, R.M. (1987). Visual parameters for color CRTs. In H. John Durrett (Ed.) Color and the Computer, New York: Academic Press, p. 77.
- Mitchell, D.E., Freeman, R.D., & Westheimer, G. (1967). Effect of orientation on the modulation sensitivity for interference fringes on the retina. J. Opt. Soc. Am. 57, 246-249.
- Nachmias, J. (1960). Meridional variations in visual acuity and eye movements during fixation. J. Opt. Soc. Am. 50, 569-571.
- Ogilvie, J.C. & Taylor, M.M. (1958). Effect of orientation on the visibility of fine wires. J. Opt. Soc. Am. 48, 628-629.

- Pointer, J.S. & Hess, R.F. (1990). The contrast sensitivity gradient across the major oblique meridians of the human visual field. Vis. Res. 30, 497-501.
- St. John, R., Timney, B., Armstrong, K.E., & Szpak, A.B. (1987). Changes in perceived contrast of suprathreshold gratings as a function of orientation and spatial frequency. Spatial Vis. 3, 223-232.
- Taylor, M.M. (1963). Visual discrimination and orientation. J. Opt. Soc. Am. 53, 763-765.

REPORT DOCUMENTATION PAGE

1a. REPORT SECURITY CLASSIFICATION UNCLASSIFIED			1b. RESTRICTIVE MARKINGS		
2a. SECURITY CLASSIFICATION AUTHORITY			3. DISTRIBUTION/AVAILABILITY OF REPORT Approved for public release; distribution unlimited		
2b. DECLASSIFICATION/DOWNGRADING SCHEDULE					
4. PERFORMING ORGANIZATION REPORT NUMBER(S) NSMRL Report # 1164			5. MONITORING ORGANIZATION REPORT NUMBER(S) NA		
6a. NAME OF PERFORMING ORGANIZATION Naval Submarine Medical Research Laboratory		6b. OFFICE SYMBOL (if applicable)	7a. NAME OF MONITORING ORGANIZATION Naval Medical Research and Development Command		
6c. ADDRESS (City, State, and ZIP Code) Naval Submarine Base New London Groton, CT 06349-5900			7b. ADDRESS (City, State, and ZIP Code) National Naval Medical Command Bethesda, MD 20889-5044		
8a. NAME OF FUNDING/SPONSORING ORGANIZATION Same as 7a		8b. OFFICE SYMBOL (if applicable)	9. PROCUREMENT INSTRUMENT IDENTIFICATION NUMBER		
8c. ADDRESS (City, State, and ZIP Code) Same as 7b			10. SOURCE OF FUNDING NUMBERS		
			PROGRAM ELEMENT NO.	PROJECT NO.	TASK NO.
			65856N	M0100	001
			WORK UNIT ACCESSION NO.		5003
11. TITLE (Include Security Classification) (U) Identification of color coded target lines of different orientations on CRT screens					
12. PERSONAL AUTHOR(S) S. M. Luria, David F. Neri, and Matthew J. Shim					
13a. TYPE OF REPORT Interim		13b. TIME COVERED FROM _____ TO _____		14. DATE OF REPORT (Year, Month, Day) 1990 December 10	15. PAGE COUNT 15
16. SUPPLEMENTARY NOTATION					
17. COSATI CODES			18. SUBJECT TERMS (Continue on reverse if necessary and identify by block number)		
FIELD	GROUP	SUB-GROUP	Sonar displays; Spatial orientation; Color coding; CRT displays; Color matching		
19. ABSTRACT (Continue on reverse if necessary and identify by block number)					
<p>Current passive broadband sonar "waterfall" displays are monochromatic, but color may be added in the future. One possible use of color would be to have the operator assign different colors to the different target tracks. The speed and accuracy of matching a colored target line on a CRT to a standard set of colors was measured as a function of the orientation of the target line. With lines one pixel wide, performance was significantly worse for diagonal than horizontal or vertical lines. There were no significant differences when the width of the line was doubled. Performance was not affected by the presence of colored distractor lines.</p>					
20. DISTRIBUTION/AVAILABILITY OF ABSTRACT <input checked="" type="checkbox"/> UNCLASSIFIED/UNLIMITED <input type="checkbox"/> SAME AS RPT. <input type="checkbox"/> DTIC USERS			21. ABSTRACT SECURITY CLASSIFICATION UNCLASSIFIED		
22a. NAME OF RESPONSIBLE INDIVIDUAL Susan D. Monty, Publications Office			22b. TELEPHONE (Include Area Code) (203) 449-3967	22c. OFFICE SYMBOL 421	