

AD _____

Award Number: DAMD17-99-1-9127

TITLE: A Novel Spatially and Temporally Inducible Gene
Expression Vector for the Treatment of Metastatic Breast
Cancer

PRINCIPAL INVESTIGATOR: Anne T'Ang, Ph.D.

CONTRACTING ORGANIZATION: Children's Hospital Los Angeles
Los Angeles, California 90027

REPORT DATE: July 2003

TYPE OF REPORT: Final Addendum

PREPARED FOR: U.S. Army Medical Research and Materiel Command
Fort Detrick, Maryland 21702-5012

DISTRIBUTION STATEMENT: Approved for Public Release;
Distribution Unlimited

The views, opinions and/or findings contained in this report are those of the author(s) and should not be construed as an official Department of the Army position, policy or decision unless so designated by other documentation.

20031216 147

REPORT DOCUMENTATION PAGE

Form Approved
OMB No. 074-0188

Public reporting burden for this collection of information is estimated to average 1 hour per response, including the time for reviewing instructions, searching existing data sources, gathering and maintaining the data needed, and completing and reviewing this collection of information. Send comments regarding this burden estimate or any other aspect of this collection of information, including suggestions for reducing this burden to Washington Headquarters Services, Directorate for Information Operations and Reports, 1215 Jefferson Davis Highway, Suite 1204, Arlington, VA 22202-4302, and to the Office of Management and Budget, Paperwork Reduction Project (0704-0188), Washington, DC 20503

1. AGENCY USE ONLY (Leave blank)		2. REPORT DATE July 2003	3. REPORT TYPE AND DATES COVERED Final Addendum (1 Jul 2002 - 30 Jun 2003)	
4. TITLE AND SUBTITLE A Novel Spatially and Temporarily Inducible Gene Expression Vector for the Treatment of Metastatic Breast Cancer			5. FUNDING NUMBERS DAMD17-99-1-9127	
6. AUTHOR(S) Anne T'Ang, Ph.D.				
7. PERFORMING ORGANIZATION NAME(S) AND ADDRESS(ES) Children's Hospital Los Angeles Los Angeles, California 90027 E-Mail: atang@chla.usc.edu			8. PERFORMING ORGANIZATION REPORT NUMBER	
9. SPONSORING / MONITORING AGENCY NAME(S) AND ADDRESS(ES) U.S. Army Medical Research and Materiel Command Fort Detrick, Maryland 21702-5012			10. SPONSORING / MONITORING AGENCY REPORT NUMBER	
11. SUPPLEMENTARY NOTES				
12a. DISTRIBUTION / AVAILABILITY STATEMENT Approved for Public Release; Distribution Unlimited				12b. DISTRIBUTION CODE
13. ABSTRACT (Maximum 200 Words) A major problem in current standard therapy for breast cancer is systemic toxicity. The overall objective of this proposal is to develop a novel strategy to confine and enhance therapeutic gene expression to tumors spatially and temporally with a novel expression vector. To achieve this, a new vector, pBF (breast tumor specific, feed forward) was constructed to selectively enhance the level of cytotoxic agents at breast tumor sites relative to the rest of the body by using a feed-forward reaction based on a combination of tissue specific promoter (cerbB2p) and the tetracycline promoter (tetp) system. By placing the coding sequence for the cytotoxic agents and that of the fusion transactivator, TETON, under the control of both cerbB2p and tetp, a feedforward reaction is triggered in the presence of tetracycline in breast tumor cells in which cerbB2 is active but not in other cell types. The overall goal is to test and optimize the system to induce the expression of cytotoxic gene products in breast tumor cells at a high and sustained level with minimal background. We have shown that a high level of cytotoxic agent can be achieved by placing multiple copies of the agent behind the tetp promoter. Weakness of the breast tumor specific promoter cerbB2 can be overcome by placing a tetp promoter behind the cerbB2 promoter. These plasmids have been transfected into breast cancer cell lines. Work is in progress to optimize the expression of these plasmids in implanted tumors in SCID mice. The validation of this gene expression vector will solve one of the major obstacles in the treatment of breast cancer (systemic toxicity) and should have significant impact on disease outcome.				
14. SUBJECT TERMS Breast cancer, gene therapy, experimental therapeutics			15. NUMBER OF PAGES 12	
			16. PRICE CODE	
17. SECURITY CLASSIFICATION OF REPORT Unclassified	18. SECURITY CLASSIFICATION OF THIS PAGE Unclassified	19. SECURITY CLASSIFICATION OF ABSTRACT Unclassified	20. LIMITATION OF ABSTRACT Unlimited	

Table of Contents

Cover	1
SF 298	2
Table of Contents	3
Introduction	4
Body	5-9
Key Research Accomplishments	9
Reportable Outcomes	10
Conclusions	10-11
References	N/A
Appendices	12

Introduction

Systemic administration of combinations of cytotoxic agents is a standard therapy for patients with hormone-refractory breast cancer. High-dose chemotherapy regimens in general result in higher complete response rates compared to conventional dose regimens. However, a major obstacle to achieving higher complete response rates is the limitation of the dose of cytotoxic agents that can be administered because of systemic toxicity. A solution to this dilemma may be to find ways to confine the administration of cytotoxic agents to the tumors or their vicinity so that tumor cells are exposed to a higher level of the cytotoxic agents relative to other tissues. The goal of this project is to develop a novel gene expression vector to confine and enhance the expression of cytotoxic gene products to tumors cells in a spatial and temporal dependent manner for the treatment of breast cancer. Our hypothesis is that the effectiveness of many cytotoxic agents will be enhanced if they can be delivered to tumors in high enough doses without causing systemic toxicity. To achieve this, expression of genes encoding cytotoxic drugs is enhanced by a feedforward reaction based on the tetracycline promoter and transactivator. Temporal and spatial expression is restricted through the use of the breast tumor specific promoter *cerbB2*. The overall goal is to test and optimize the system to induce the expression of cytotoxic gene products in breast tumor cells at a high and sustained level with minimal background.

Addendum to Final Report

This report is an addendum to the final report submitted last year. A one year no-cost extension was requested to complete the work.

The purpose of this project is to improve the treatment of metastatic breast cancer by localizing the expression of cytotoxic agents using a novel gene expression vector. Our hypothesis is that the effectiveness of many cytotoxic agents will be enhanced if they can be delivered to tumors in high enough doses without causing systemic toxicity. To achieve this, a vector containing a modified radiation inducible promoter, pRIBs (Radiation Inducible, Breast specific Promoter), was developed to enhance, prolong and confine the expression of cytotoxic genes in irradiated metastatic breast tumors while minimizing toxicity. In a hypothetical treatment scheme, pRIBs-TNF α is delivered systemically in a liposome complex or as a recombinant virus to tumor and normal cells alike. Without radiation and tetracycline, TNF α is not expressed. Oxytetracycline is then administered systemically followed by x-ray irradiation of known metastatic tumor sites. As a result, TNF α expression is induced in the tumor sites by the x-ray and greatly amplified and maintained by oxytetracycline. Even though not all tumor cells may take up pRIBs-TNF α , tumor cells in the vicinity of those that do are exposed to the very high local concentrations of secreted TNF α . The design of pRIBs-TNF α confers TNF α expression in the breast tumor cells only and not in the irradiated normal cells that were in the pathway of the x-rays. As such, systemic toxicity, if any, is limited to the low level of TNF α diffused from the tumor cells.

The construction and testing of this plasmid has been completed and described in the final report. Problems encountered with low expression was discussed. The vector was modified several times till good expression in vitro was obtained with the vector pBF shown below.

pBF

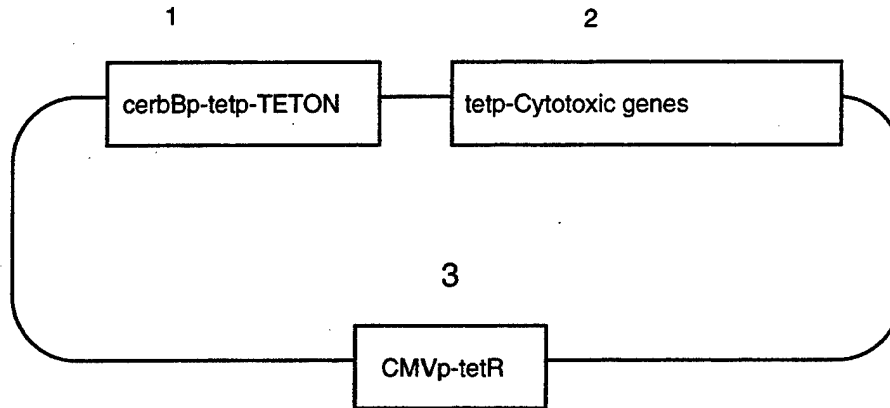

Figure 1 Structure of pBF

- CMVp-tetR(3) binds to tetp in the absence of doxycycline to repress the non-TETON transcription from tetp
- Multiple copies of one or more tetp-cytotoxic drugs ensures that tetp-TETON is fully utilized to produce abundant amount of cytotoxic drugs

In this vector, tetON is placed under the control of both the cerbB2 promoter and the tetracycline-inducible promoter to amplify the level of tetON produced by the weak cerbB2 promoter. Another consideration is that the high level of tetON must be matched by a high number of tetp promoters to which tetON binds. Therefore new vectors containing one, two and four copies of tetp-TNF α were made (cassette 2) and tested.

Before assembling all the components of the cassette, we tested each component separately by cotransfecting plasmids containing one, two or four copies of TNF α together with CMVteton into Saos-2 cells. As reported last year, TNF α production can be increased by using multiple copies of tetpTNF α .

Testing tetpTNF α

Plasmids containing 1,2 and 4 copies of tetpTNF α were cotransfected with CMVteton into Saos-2 cells. We chose this cell line to do the test because it can be transfected efficiently. After 48 hours, cells were treated with 0.2 μ g/ml doxycycline. Supernatants were harvested after 24hours and TNF α concentrations determined by ELISA.

*

Figure 2 Testing tetpTNF α

Figure 2 shows the fold increase in TNF α levels over background level for (1) one (2) two and (3) four copies of TNF α . The data shows that TNF α production can be increased by using multiple copies of tetpTNF α .

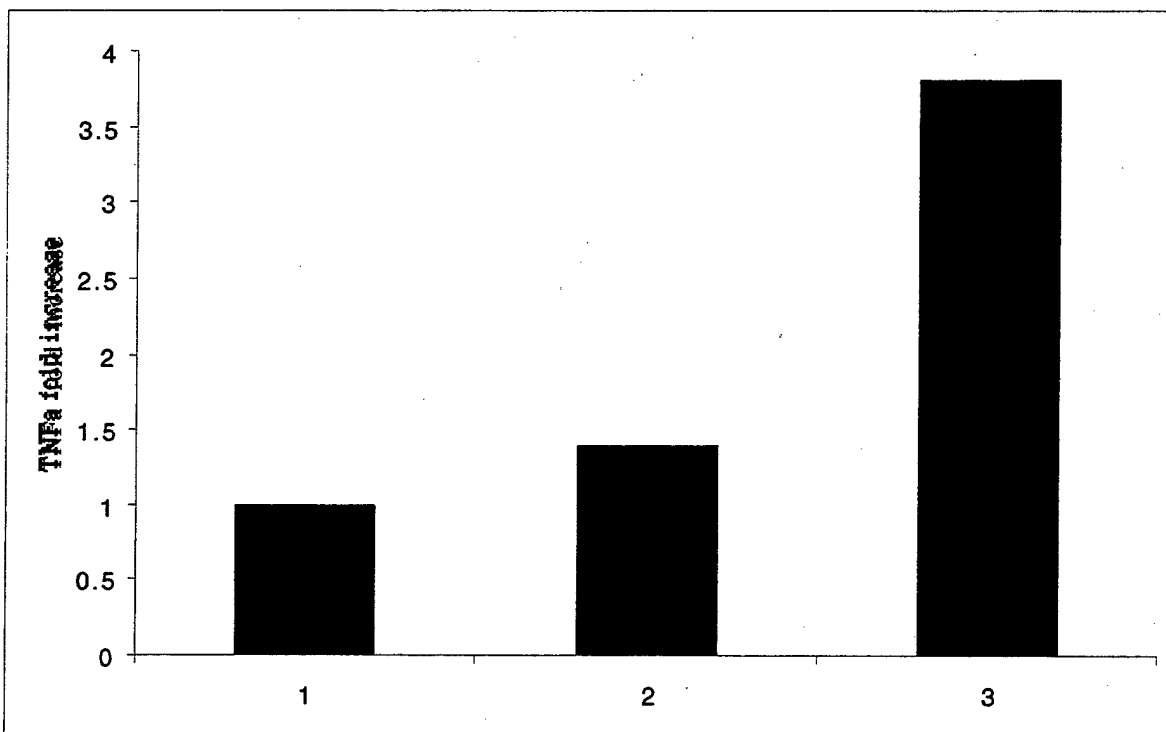

Testing cerbB2teton versus cerbB2tetpteton

Our hypothesis is that by placing tetp behind cerbB2, the initial amount of tetON produced specifically in cerbB2 expressing cells will be further amplified. To prove this, we compared this plasmid with one in which tetON is placed directly behind the cerbB2 promoter. CerbB2-teton or cerbB2tetpteton was cotransfected with 4 copies of tetpTNF α into BT483 cells. After 2 days, the cells were treated with doxycycline

*

(0.2ug/ml) and the supernatant harvested after 24hours and ELISA performed. We expect that since cerbB2 is a very weak promoter, the amount of tetOn produced from cerbB2tetON will be less than for cerbB2tetptetON, and therefore less TNF α will be produced. As shown below, this is indeed the case.

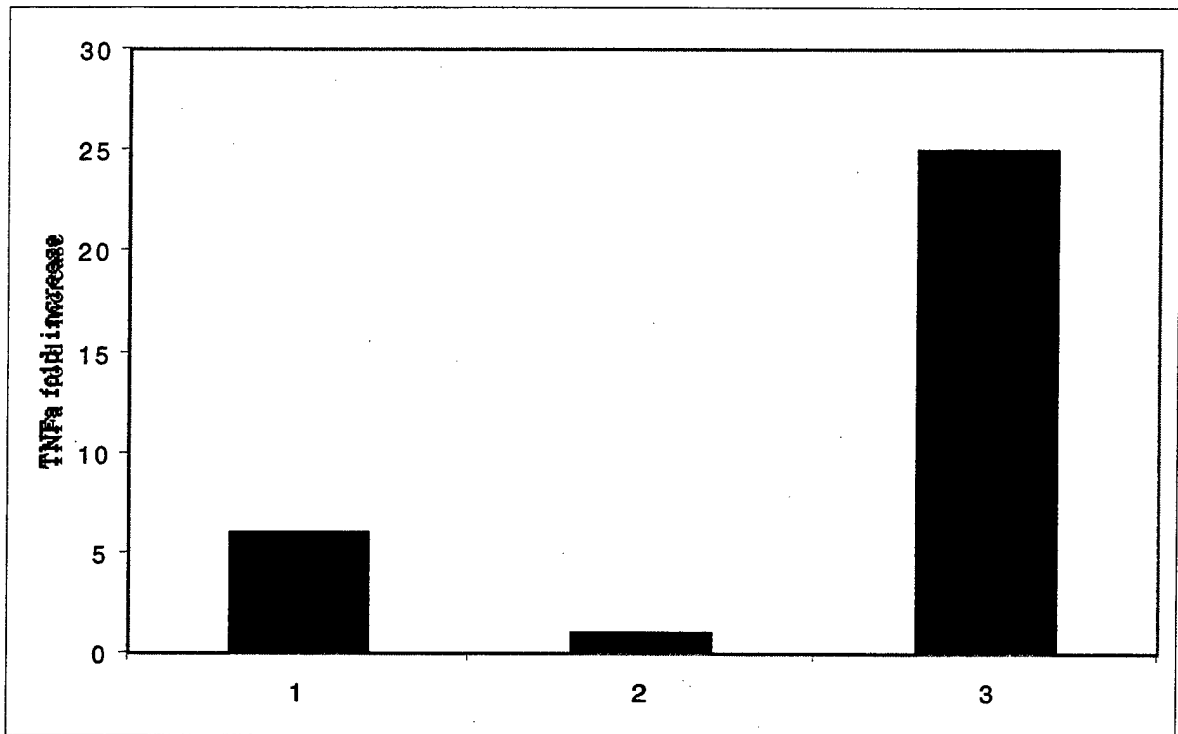

Fig. 3 Comparing cerB2teton and cerbB2tetpteton
Fold enhancement of TNF α levels over background. (1) tetpTNF α tetramer + CMVteton
(2) tetpTNF α tetramer + cerbB2teton and (3) tetpTNF α tetramer + cerbB2tetpteton

In the original plasmid design, CMVptetR was used to suppress any background non-tetON driven transcription in the absence of doxycycline. Our data shows that in vitro, background expression of TNF α is null to very low and this cassette may not be necessary. However, this may not be the case in vivo, therefore, we created vectors with and without this cassette. Thus we have created plasmids containing (A)cassettes 1+2 and (B)1+2+3. Since we have already shown that TNF α can be expressed from cassettes 1 and 2, plasmid A was transfected into BT483 (high c-erbB2 , MDA-MB436 (low c-erbB2) and Saos-2 (non-breast tumor) and colonies selected. Colonies were tested and two clones from each cell line expressing high levels of TNF α were selected for implantation into nude mice.

Experiments were performed to determine the best conditions of tetracycline administration for inducing the transfected plasmid in vivo. 5 X10⁶ cells from each clone were implanted into the flanks of nude mice. After the tumors grew to 0.5 cm in size, the animals were given an injection of oxytetracycline (0, 5,10,15 ug/g) and tumor tissue collected at 0, 4, 8, 12 and 24 hours. Because the tumors from different cell lines grew at different rates, the tumors were snap frozen in liquid nitrogen after treatment and stored in -70^o C so that TNF α levels of the different groups can be measured at the same time. Preliminary experiments using samples obtained from the highest dose of oxytetracycline showed very low levels of TNF α . This may be due to suboptimal extraction of TNF α from the tissues. We are now experimenting with different extraction methods. In addition, we are checking levels of teton protein by western blotting to determine if the problem is insufficient induction of teton in vivo.

Key Research Accomplishments

- pRIBs-1-GFP vector as originally proposed was constructed and transfected into three cell lines. Expression of GFP was found to be low even in the high cerbB2 expressing cell line.
- Even at a ratio of 20:1 CMVteton : DNTet, the dominant negative cassette led to a 66.7% suppression. Therefore, instead of testing 1 and 4 copies of dominant negative cassette as originally proposed, we will modified the vector to test 0 and1 copies.
- Based on the above data, an improved versions of the vector, pRIBs-2 was designed and constructed.
- pRIBs-2 was transfected into two cell lines, and expression of TNF α was found to be low even in the high cerbB2 expressing cell line
- a modified vector pBF was constructed to increase the expression of TNF α
- Individual components of pBF were tested by transfection and high levels of TNF α were achieved
- Stable transfectants of pBF in three different cell lines were selected and tested for TNF α expression. Two of the highest TNF α -expressing clones from each cell

line was selected and implanted into SCID mice. After the tumors grew up, the animals were treated with different doses of oxytetracycline and the tumors removed at different time points. Experiments are now in progress to determine the optimal method for extraction of TNF α in order to compare the TNF α levels in these samples.

Reportable Outcomes

Patent#79035 granted in Singapore : "Methods to Enhance and Confine Expression of Genes"

Abstract/Poster Presentation at Era of Hope Meeting, Orlando, Florida, Sept. 25-28,2002 "A novel spatially and temporally inducible gene expression vector for the treatment of metastatic breast cancer" Anne T'ang, Hui Yang, Xiang-he Shi, Yuen Kai T.Fung

Conclusion

In year one, we constructed pRIBs-1-GFP. The purpose of this vector is two fold: (1) to enhance the expression of genes encoding cytotoxic drugs by a feedforward reaction based on the tetracycline promoter and transactivator, and (2) to restrict the expression of the cytotoxic agents through the use of radiation inducible promoter EGR β and breast cancer specific expression promoter cerbB2 . Antisense and dominant negative DNA elements were designed to reduce the background problem of the radiation promoter. While testing this vector, we came across several findings which led us to improve on the original vector design. The dominant negative cassette was found to be much stronger than we had anticipated, therefore, we decided to use fewer (or no) copies. Other improvements were also made in the design of the new vectors (pRIBs-2) to enhance expression of the cytotoxic gene as discussed above. In year 2, we completed the construction of pRIBs-2 but found that expression of TNF α was low. We attributed this to the possibility that the 2-hybrid system is not working efficiently due to the weakness of the cerbB2 and EGR β promoters. We modified the vector to express TNF α directly from the tetp promoter, and to express tetON from both the cerbB2 and tetp promoters. We also tested multiple copies of TNF α . A much higher level of TNF α was achieved. In year 3, we completed isolation of stable transfectants, and tested them for TNF α expression. Clones expressing high levels of TNF α were transplanted into scid mice. Experiments are now in progress to measure the TNF α levels in vivo and to maximize expression levels by adjusting the dose and schedule of tetracycline administration.

Systemic toxicity is a major problem in designing combination therapy protocols. Many clinical studies are aimed at testing the dose and administration schedule for therapeutic gains. Successfully optimized, our vector should minimize the problem of systemic toxicity and greatly raise the dose of a number of cytotoxic agents that can be administered in the treatment of breast cancer. New cytotoxic gene products with different tumoricidal mechanisms may be introduced in combination regimens. The validation of this gene expression vector and strategy will solve one of the major obstacles in the treatment of breast cancer and should have substantial impact on disease outcome.

Appendix

A. Acronyms and Symbols Definition

- pRIBs - Radiation Inducible, Breast specific Promoter. A selectable plasmid containing a radiation -inducible Egr-1 promoter and several gene cassettes that regulate gene expression
- TNF α - tumor necrosis factor alpha
- HSP - heat shock protein
- TET-ON - a fusion of the coding sequences for amino acids 1-207 of the tet repressor and the c-terminus last 130 amino acids transcription activation domain of the VP16 protein of the herpes simplex virus. TET-ON is inactive in the absence of tetracycline but become activated when bound to it.
- tetp - The tet operator consisting of the 19 bp inverted repeats of the operator O2 of TN10 to which the tet repressor and TET-ON bind, linked to the minimal CMV promoter, mpCMV.
- CMV-tetR- the DNA-binding domain of the tet repressor, binds DNA in the absence of tetracycline.

B. Personnel

The following personnel have received pay from this grant:-

Anne T'ang, PhD, Principal Investigator
Shumin Wen, PhD, postdoctoral fellow
Xiang-He Shi, MD, Research Associate
Denysha Carbonell, B.S., Research Specialist