

U.S. Coast Guard Research and Development Center

1082 Shennecossett Road, Groton, CT 06340-6048

Report No. CG-D-11-03

Standardized Sampling Protocol for Verifying Mid-Ocean Ballast Water Exchange



**FINAL REPORT
SEPTEMBER 2003**

This document is available to the U.S. public through the
National Technical Information Service, Springfield, VA 22161

Prepared for:

Report Documentation Page

Form Approved
OMB No. 0704-0188

Public reporting burden for the collection of information is estimated to average 1 hour per response, including the time for reviewing instructions, searching existing data sources, gathering and maintaining the data needed, and completing and reviewing the collection of information. Send comments regarding this burden estimate or any other aspect of this collection of information, including suggestions for reducing this burden, to Washington Headquarters Services, Directorate for Information Operations and Reports, 1215 Jefferson Davis Highway, Suite 1204, Arlington VA 22202-4302. Respondents should be aware that notwithstanding any other provision of law, no person shall be subject to a penalty for failing to comply with a collection of information if it does not display a currently valid OMB control number.

1. REPORT DATE 00 SEP 2003	2. REPORT TYPE N/A	3. DATES COVERED -			
4. TITLE AND SUBTITLE Standardized Sampling Protocol for Verifying Mid-Ocean Ballast Water Exchange		5a. CONTRACT NUMBER			
		5b. GRANT NUMBER			
		5c. PROGRAM ELEMENT NUMBER			
6. AUTHOR(S)		5d. PROJECT NUMBER			
		5e. TASK NUMBER			
		5f. WORK UNIT NUMBER			
7. PERFORMING ORGANIZATION NAME(S) AND ADDRESS(ES) Center for Lake and Reservoir Study, United States Coast Guard, Marine Safety and Environmental Protection (G-M), Washington, DC 20593-0001 and U.S. Coast Guard, Research and Dev Ctr., 1082 Shennecossett Rd., Groton, CT 06340-6048		8. PERFORMING ORGANIZATION REPORT NUMBER			
		10. SPONSOR/MONITOR'S ACRONYM(S)			
9. SPONSORING/MONITORING AGENCY NAME(S) AND ADDRESS(ES)		11. SPONSOR/MONITOR'S REPORT NUMBER(S)			
		12. DISTRIBUTION/AVAILABILITY STATEMENT Approved for public release, distribution unlimited			
13. SUPPLEMENTARY NOTES The original document contains color images.					
14. ABSTRACT					
15. SUBJECT TERMS					
16. SECURITY CLASSIFICATION OF:			17. LIMITATION OF ABSTRACT UU	18. NUMBER OF PAGES 48	19a. NAME OF RESPONSIBLE PERSON
a. REPORT unclassified	b. ABSTRACT unclassified	c. THIS PAGE unclassified			

U.S. Department of Homeland Security
United States Coast Guard
Marine Safety and Environmental Protection (G-M)
Washington, DC 20593-0001

N O T I C E

This document is disseminated under the sponsorship of the Department of Homeland Security in the interest of information exchange. The United States Government assumes no liability for its contents or use thereof.

The United States Government does not endorse products or manufacturers. Trade or manufacturers' names appear herein solely because they are considered essential to the object of this report.

This report does not constitute a standard, specification, or regulation.



Marc B. Mandler, Ph.D.
Technical Director
United States Coast Guard
Research & Development Center
1082 Shennecossett Road
Groton, CT 06340-6048

1. Report No. <p style="text-align: center;">CG-D-11-03</p>		2. Government Accession Number		3. Recipient's Catalog No.	
4. Title and Subtitle Standardized Sampling Protocol for Verifying Mid-Ocean Ballast Water Exchange				5. Report Date September 2003	
				6. Performing Organization Code Project No. 4124	
7. Author(s) Kate Murphy, Gregory Ruiz, Mark Sytsma				8. Performing Organization Report No. R&DC 602	
9. Performing Organization Name and Address Center for Lake and Reservoir Study Portland State University Portland, OR 97207-0751		U.S. Coast Guard Research and Development Center 1082 Shennecossett Road Groton, CT 06340-6048		10. Work Unit No. (TRAVIS)	
				11. Contract or Grant No. DTCG32-02-C-R00005	
12. Sponsoring Organization Name and Address U.S. Department of Homeland Security United States Coast Guard Marine Safety and Environmental Protection (G-M) Washington, DC 20593-0001				13. Type of Report & Period Covered Final 14. Sponsoring Agency Code Commandant (G-MSO-4) U.S. Coast Guard Headquarters Washington, DC 20593-0001	
15. Supplementary Notes The R&D Center's technical point of contact is Penny Herring, 860-441-2868, e-mail: pherring@rdc.uscg.mil.					
16. Abstract (MAXIMUM 200 WORDS) <p>Laws designed to reduce the number of introductions of aquatic nuisance species into U.S. waters require ships from outside the Exclusive Economic Zone to conduct mid-ocean ballast water exchanges (BWE) before entering the Great Lakes and upper Hudson River. The National Invasive Species Act of 1996 requests ships entering any U.S. waters to conduct BWE. Because of low voluntary compliance, the U. S. Coast Guard recommended to Congress that BWE become mandatory in all waters.</p> <p>When BWE becomes mandatory, the Coast Guard must have means to verify whether BWE occurred. Early research identified several potential characteristics of open ocean and coastal waters that might be used in verification. The Coast Guard sought standardized sampling and handling protocols such that multiple researchers could pursue this issue and have compatible results. This report provides protocols for sampling and handling colored, dissolved organic matter, trace metals, and radium. It gives an overview of the parameters, discusses sampling apparatus and specifications, provides detailed protocols, and explains sample storage prior to shipment. It addresses contamination, representative samples, obtaining blanks, sampling over-the-side, and standardization.</p> <p>Information obtained using these protocols will allow better characterization of open ocean and coastal water, and will enhance the Coast Guard's ability to verify BWE.</p>					
17. Key Words protocol, ballast water exchange, verification, mid-ocean, trace metals, colored dissolved organic matter, radium			18. Distribution Statement This document is available to the U.S. public through the National Technical Information Service, Springfield, VA 22161		
19. Security Class (This Report) UNCLASSIFIED		20. Security Class (This Page) UNCLASSIFIED		21. No of Pages	22. Price

Form DOT F 1700.7 (8/72) Reproduction of form and completed page is authorized.

Acknowledgements

We would like to acknowledge several people who were instrumental in developing the protocols presented in this document. Dr. Paula Coble provided information on sampling for colored dissolved organic matter (CDOM), Dr. Willard Moore proposed the protocols used to sample for radium isotopes, and Drs. Paul Field and Jay Cullen assisted with the protocols for trace metal sampling.

The methods described herein were tested on commercial ships with assistance from Brian Steves, Alan Burdick, Andrew Chang, George Smith and Esther Collinetti.

Many people contributed ideas to this project during an initial workshop session. These included Dr. Larry Brand, Dr. Fred Dobbs, Dr. Rich Everett, Mark Geiger, Penny Herring, Dr. Chad Hewitt, Dr. Robert Hiltabrand, LT Mary Pat McKeown, Dr. Patrick Louchouart, Dr. Whitman Miller, Jae Ryoung Oh and Dr. Patricia Tester. Dr. Elgin Perry has contributed statistical advice on this project.

Useful comments on earlier drafts of this document were received from Robyn Draheim, Penny Herring, Russ Herwig, Emma Verling and Jordan Vinograd.

Executive Summary

In 1990 Congress passed the Nonindigenous Aquatic Nuisance Prevention and Control Act (NANPCA) in an effort to slow the introduction of Aquatic Nuisance Species (ANS) into the Great Lakes and the upper Hudson River. Under NANPCA, ships entering these waters were required to conduct a mid-ocean ballast exchange (or use an equivalent treatment) such that any water released during deballasting would be oceanic rather than coastal. The Coast Guard was tasked with enforcing that requirement and routinely uses salinity readings to verify that ballast water exchange (BWE) has been carried out. Currently, a salinity determination of 30 parts per thousand is used as the indicator of an acceptable exchange.

In 1996, Congress reauthorized NANPCA with the National Invasive Species Act (NISA) and expanded Coast Guard's area of ANS concern to include all U. S. waters. Under NISA, ships entering any U. S. port, other than the areas delimited by NANPCA, are requested to carry out BWE and are required to submit information on their ballast water management practices. After two years of collecting data from mandatory reports, it was found that only 30.4 percent of ships even filed reports and approximately 51.2 percent of those actually performed the BWE. The Coast Guard has therefore recommended to Congress that BWE become mandatory for all ships entering U. S. waters from beyond the Exclusive Economic Zone.

BWE and holding ballast onboard are the two most common ballast management practices today. At present, BWE is verified using the 30 parts per thousand salinity criterion even though it is recognized that this is insufficient to verify exchange if the original ballasting took place in high salinity ports. With the recommendation that BWE become mandatory for all ships comes the requirement to be able to differentiate between exchanged and unexchanged water in ballast tanks. In effect this means distinguishing between open ocean and coastal water. An initial study solicited recommendations from a panel of experts for parameters that varied from coastal waters to offshore waters. At-sea investigations of the most promising parameters led to the identification of several parameters that, when combined with salinity, could potentially identify water as either open ocean or coastal.

To augment the initial findings, a second study was initiated. Part of that study included solidifying the sampling and handling protocols for these parameters. The protocols presented in this document are the result of those two studies. It is recognized that coastal and open ocean waters are highly variable, both temporally and geographically. Likewise, the expense in both time and money of obtaining sufficient coastal and ocean samples to fully characterize the distribution of parameters is prohibitive for a single

agency. The use of standardized protocols and analysis procedures by multiple nations and agencies will help provide sufficient data to define the parameter distribution. When these parameters are coupled with salinity, a determination of BWE can be made.

The goal of this document is to provide background information and specific protocols to allow researchers worldwide to plan for and obtain samples to describe the characteristics of water masses where ballast water might be taken up or exchanged. The potential for contamination from both the ship and the sampling and storage equipment is discussed. The suitability of different materials for contact with the selected parameters (colored dissolved organic matter, trace metals, and radium) is provided to allow selection of appropriate equipment. Suggestions for equipment include descriptions of pumps, water sampling devices, profiling equipment, filters, and specialized rosin cartridges. Access to ballast tanks is discussed along with precautions to be taken when profiling or sampling tanks.

For each of the parameters (salinity, colored dissolved organic matter, trace metals, and radium), a specific protocol is presented. Each includes a brief overview of the parameter, a description of the sampling apparatus, a description of the sample to be obtained, a brief summary of laboratory preparation of the sample devices and sample containers, a step-by-step procedure for shipboard sampling, examples of logbook entries, and handling and treatment procedures for getting the samples to the laboratory. In addition, protocols for obtaining blanks are provided. Methods for obtaining over-the-side samples are also discussed.

The ultimate Coast Guard goal is the ability to verify that a ship has indeed conducted a ballast water exchange in mid-ocean. The information presented in this document should be sufficient for researchers to replicate the methodology already in use, which in turn will allow comparisons of data from very different geographical and water quality regions to existing data. This will aid in the characterization of coastal water differences from open ocean water, and this characterization will lead to the Coast Guard's goal. The protocols themselves will have to be modified before they can be used for Coast Guard enforcement operations.

Finally, it is recognized that the protocols presented in this document are subject to change as methodologies and technologies improve. They do, however, form a framework upon which new methodologies can build. The protocols presented here are therefore considered as Version 1 of an evolving research effort.

Table of Contents

<u>1</u>	<u>Introduction</u>	1
2	Ships, Tanks and Sampling Designs	3
2.1	<u>Representative Sampling</u>	3
2.2	<u>Tank Configurations and Access Ports</u>	3
2.2.1	<u>Hatches and Manholes</u>	6
2.2.2	<u>Sounding Pipes</u>	6
2.3	Instrument Deployment Into Tanks	7
<u>3</u>	<u>Ships and Contaminants</u>	10
<u>4</u>	<u>Ballast Water Sampling Apparatus</u>	12
4.1	<u>Discrete Samplers versus Profiling Instruments</u>	12
4.2	<u>Niskin Bottles</u>	12
4.3	<u>Syringe Samplers</u>	13
4.4	<u>Pumps</u>	13
4.4.1	<u>Power Supply</u>	13
4.4.2	<u>Capacity</u>	14
4.4.3	<u>Performance</u>	14
4.4.4	<u>Materials</u>	14
4.4.5	<u>Air Hose Couplings</u>	14
<u>5</u>	<u>Ballast Water Sampling Protocols</u>	16
5.1	<u>Diaphragm Pump Configuration</u>	16
5.1.1	<u>Overview</u>	16
5.1.2	<u>Equipment Specifications</u>	16
5.2	<u>Salinity Sampling Protocol</u>	17
5.2.1	<u>Overview</u>	17
5.2.2	<u>Sampling Apparatus</u>	17
5.2.3	<u>Procedure</u>	18
5.3	<u>Trace Metal Sampling Protocol</u>	19
5.3.1	<u>Overview</u>	19
5.3.2	<u>Sampling Apparatus</u>	19
5.3.3	<u>Equipment Specifications</u>	20
5.3.4	<u>Products</u>	20
5.3.5	<u>Procedure</u>	20

5.3.6	Sample Log	21
5.3.7	Sample Delivery to Analytical Laboratories	24
5.4	Colored Dissolved Organic Matter (CDOM) Sampling Protocol	24
5.4.1	Overview	24
5.4.2	In-situ CDOM Fluorometers	25
5.4.3	Sampling Apparatus	25
5.4.4	Equipment Specifications	25
5.4.5	Products	26
5.4.6	Procedure	26
5.4.7	Sample Log	27
5.4.8	Sample Delivery to Analytical Laboratories	28
5.5	Radium Sampling Protocol	28
5.5.1	Overview	28
5.5.2	Sampling Apparatus	28
5.5.3	Equipment Specifications	29
5.5.4	Products	29
5.5.5	Procedure	29
5.5.6	Sample Log	31
5.5.7	Sample Delivery to Analytical Laboratories	31
5.6	Blank Sampling Protocol	32
5.6.1	Overview	32
5.6.2	Sampling Apparatus	33
5.6.3	Products	33
5.6.4	Procedure	33
5.7	Ship-side Sampling Protocol	34
5.7.1	Overview	34
5.7.2	Procedure	34
6	Conclusions and Recommendations.....	32
7	References.....	36

List of Figures

Figure 1: Ballast tank access locations on a bulk cargo ship.	5
Figure 2: Common ballast tank configurations on tanker ships.	8
Figure 3: Niskin bottle sampler.	10
Figure 4: Syringe sampler.	11
Figure 5: Types of air hose couplings commonly encountered on ships.	15
Figure 6: Diaphragm pump set-up for ballast water sampling.	17
Figure 7: Trace Metal Pump Sampling Apparatus.	20
Figure 8: CDOM pump sampling apparatus.	25
Figure 9: Radium Pump Sampling Apparatus.	29
Figure 10: Conceptual diagram of pre-blank and blank samples.	29
Figure 11: Preventing CDOM and trace metal bottle breakages during freezing.	34

List of Tables

Table 1: Contaminants on Ships	10
Table 2: Materials compatibility	11
Table 3: Trace metal sampling procedure – 2-person protocol	23
Table 4: Example logbook entries for trace metal samples	24
Table 5: Example logbook entries for CDOM samples	27
Table 6: Example logbook entries for radium samples	31

Acronyms

ANS	Aquatic Nuisance Species
BWE	Ballast Water Exchange
CDOM	Colored Dissolved Organic Matter
cm	Centimeter
DB	Double Bottom
DO	Dissolved Oxygen
EEMS	Emission Excitation Matrix Spectroscopy
EEZ	Exclusive Economic Zone
gal	Gallon
L	Liter
lb	Pound
m	Meter
µm	Micron
mm	Millimeter
min	Minute
mL	Milliliter
Milli-Q	Ultra-clean water treated via a Milli-Q® system
NANCPA	Nonindigenous Aquatic Nuisance Prevention and Control Act
NISA	National Invasive Species Act
ppt	Parts per thousand
psu	Practical Salinity Unit
PVC	Polyvinyl Chloride
U.S.	United States
W	Wing Tank
YSI	Yellow Springs Instruments
°C	Degrees Celsius
Ag	Silver
Al	Aluminum
Ba	Barium
Cu	Copper
Fe	Iron
Mn	Manganese
Ni	Nickel
P	Phosphorus
Th	Thorium
U	Uranium
V	Vanadium
Zn	Zinc
MnO ₂	Manganese Oxide
²²³ Ra, ²²⁴ Ra, ²²⁶ Ra, ²²⁸ Ra	Isotopes of Radium

1 Introduction

The expansion of aquatic nuisance species (ANS) into new habitats has increased dramatically in the past few decades in both United States (U.S.) waters and the rest of the world. In 1990, Congress passed the Nonindigenous Aquatic Nuisance Prevention and Control Act (NANPCA) (PubL. 101-646) in an effort to halt introductions of ANS into the Great Lakes and upper Hudson River. In 1996 this was amended and reauthorized as the National Invasive Species Act (NISA) (PubL. 104-332). NISA called for ballast water management to prevent the introduction and spread of ANS and greatly expanded the role of U. S. Coast Guard regulations to all U. S. waters.

The most prevalent ballast water management technique today is mid-ocean ballast water exchange (BWE). Under NANPACA, ships entering the Great Lakes and upper Hudson River were required to conduct BWEs before entering the U. S. Exclusive Economic Zone (EEZ). Under NISA, it was voluntary for ships entering other ports to conduct BWE and mandatory to report their actions. After several years of monitoring ballast water management activity under NISA, it was found that voluntary BWE was not effective. The Coast Guard is thus planning to make BWE mandatory for all ships entering any port in U. S. waters from outside the EEZ. Once this regulation is enacted, Coast Guard must be able to verify compliance. Accordingly, methods have been sought to enable Coast Guard to discriminate between exchanged and unexchanged water.

As a result of discussions by a panel of experts, a suite of parameters that could potentially differentiate between open ocean and coastal water were identified. A selected subset of these parameters was investigated during oceanic cruises and the most promising parameters identified (Murphy et al, 2003). The protocols for sampling ballast tanks to quantify concentrations of trace metals, colored dissolved organic matter (CDOM), and radium isotopes were first implemented during these cruises and have been refined as part of the Columbia River Aquatic Nuisance Species Initiative research program. Although these protocols have been tested exclusively on wing tanks, it is expected that the same protocols are readily transferable to other ballast tanks accessed from the deck (Cargo Holds and Fore/Aft Peaks). Significant modifications may be required to sample double-bottom tanks.

The purpose of publishing these protocols is two-fold. The first is to provide enough detail to allow other researchers to replicate the methodology already in use, thereby facilitating data accumulation and allowing comparisons across different geographical regions and timeframes as similar research takes place globally.

The second reason is to provide Coast Guard with a framework of sampling methods upon which to base standard protocols for verifying BWE for enforcement purposes.

It is recognized that the protocols presented in this document are subject to change as methodologies and technologies improve. Thus, the sound and concise protocols of this document are to be considered as Version 1 of an evolving research effort.

2 Ships, Tanks and Sampling Designs

2.1 Representative Sampling

The overriding goal when sampling a ship's ballast tank is to obtain enough samples to accurately and sufficiently characterize the ballast water. Replicate profiles obtained from a particular location in the tank can yield precise measurements at that location. However, it may be argued that replicate profiles taken from a single location underrepresent the true variability in the tank by failing to account for spatial differences.

“Representative sampling” is a statistical term used to describe the practice of obtaining samples that provide an unbiased estimate of a population. Non-representative ballast water sampling can occur when the number of samples collected is too few to describe the natural variability in the ballast tank, or when a disproportionate number of samples are obtained from regions of a ballast tank that differ significantly from other regions of the tank. In this case, there exists the risk that any non-compliance determination could be discounted (i.e., either in a scientific venue or a court of law), on the basis that measured concentrations were uncharacteristic.

If the distribution of tracers in a ballast tank is unknown prior to sampling, measurements should be obtained from more than one location in the tank (e.g. forward and aft manholes) and at more than one depth (particularly if the tank is stratified). Where possible, samples should be collected from more than one ballast tank. It is far better to obtain more samples than one intends to analyze, than to collect too few or atypical samples, particularly if a ship appears not to have performed ballast water exchange. Any shortcuts or lack of due diligence on deck may compromise the quality and utility of the resulting information.

2.2 Tank Configurations and Access Ports

In theory, ballast tanks can be accessed from deck via manholes, hatches, vents and sounding pipes (Figure 1). In practice, a subset of these options are often unavailable on a target ship: manholes may be under pressure or obstructed by cargo, vents may be closed with wire mesh, and hatches or sounding pipes may be absent.

The most difficult tanks to sample quantitatively are those in which access is severely restricted by design or safety issues. Because cargo holds can usually be accessed to their full depth through the open hatch, they are generally more amenable to representative sampling than are wing or double-bottom tanks. It is

often impossible to access the entire depth profile of a wing tank except directly below a manhole, while in many cases, ladders and other tank structures below manholes prevent access to all but the top few meters



A. Manhole and vent

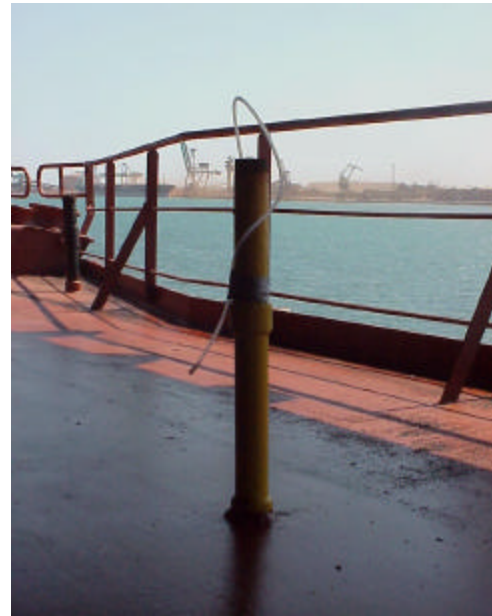

B. Sounding pipe, with pump tubing inserted



C. Hatch

Figure 1: Ballast tank access locations on a bulk cargo ship.

(Figure 2). Pre-inspections of empty ballast tanks, and/or custom-made sampling equipment may be highly beneficial to representative sampling efforts. While the best information is always obtained by visual inspection, design plans showing the dimensions of the ballast tanks provide a useful overview of tank design, and may alert you to problems ahead of time.

If it is not possible to view empty ballast tanks prior to sampling, design plans showing the dimensions of the ballast tanks should be obtained from the ship. Samples should be taken from as many tanks, depths and locations as are feasible. Mark all sampling positions on the design plans as this information may be needed to interpret the resulting data.

2.2.1 Hatches and Manholes

In most cases, tanks can be accessed by at least one manhole/hatch of > 30 cm (~12 inches) diameter. In some cases, there will be two or three access points of this type. Access via a manhole will usually require the removal of 10 – 30 bolts by a crewmember via wrench or air gun. Hatches are opened by unscrewing a single large wing nut that prevents the lid from swinging open.

2.2.2 Sounding Pipes

Sounding pipes are narrow metal tubes that connect a tank to the deck (Figure 1B). Their purpose is to guide a sounding tape as it is lowered in order to estimate the level of fluid in the tank. The sounding pipe may be a continuous tube insulated from the rest of the tank except at the bottom end, or it may have perforated sections that encourage exchange between the pipe and surrounding ballast water. Sounding pipes may be straight or have bends that could prevent the passage of an instrument larger than the weight at the end of a sounding tape. Usually, the exact configuration of a sounding pipe will not be known prior to sampling.

Until proven otherwise, sounding pipes should be treated as specialized micro-environments that are probably not representative of the remainder of the ballast tank. For this reason, collecting BWE verification samples from sounding pipes is not recommended except to supplement other tank samples or where there are no alternative access locations. Should it be necessary to sample ballast tanks via sounding pipes, Dodgshun and Handley (1997) of the Cawthron Institute in New Zealand have published a procedure for using impeller and inertia pumps to obtain water from sounding pipes.

Discussions in the remainder of this document regarding apparatus, protocols and contaminants are also relevant to sampling via sounding pipes.

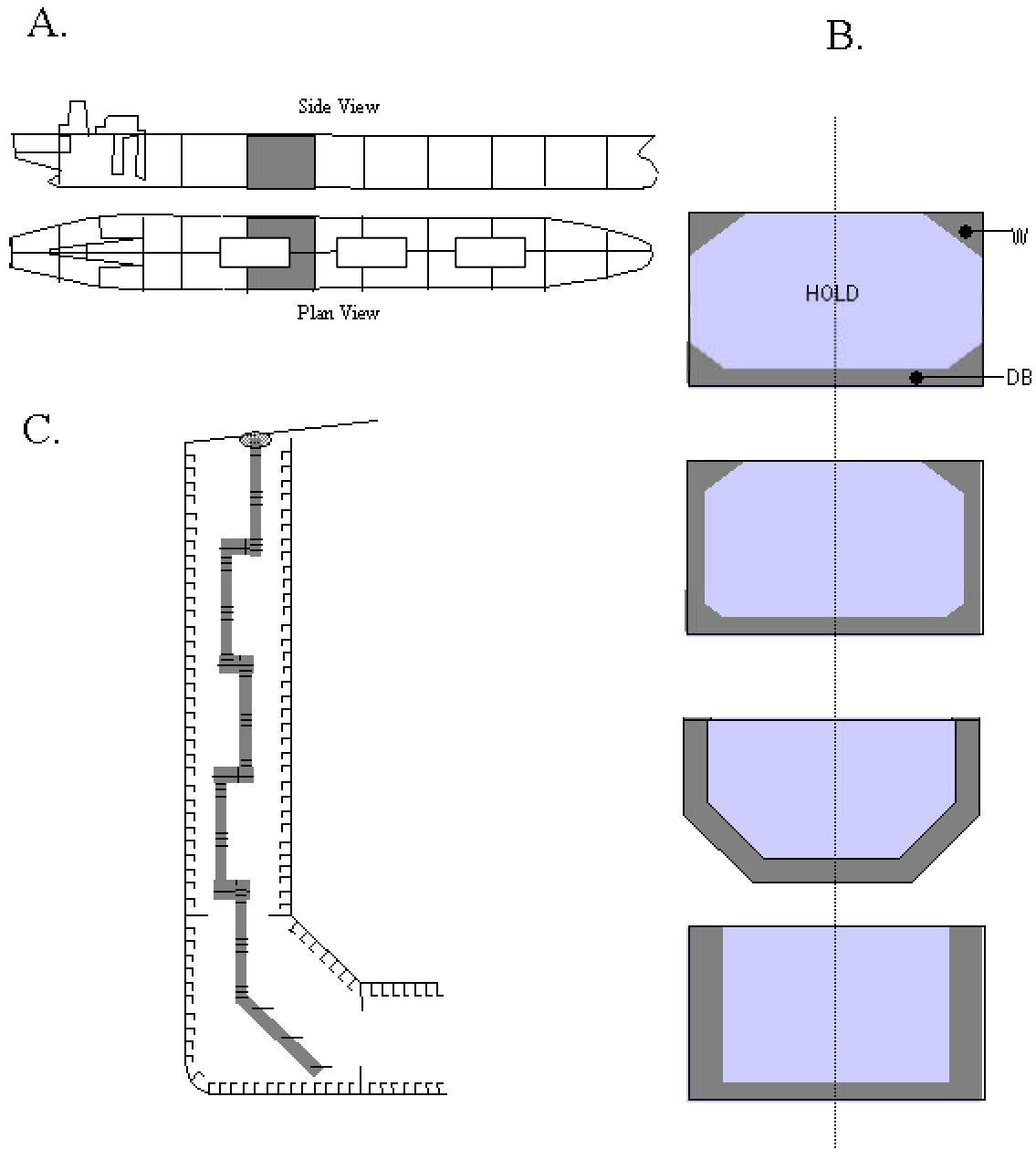

Figure 2: Common ballast tank configurations on tanker ships.

- A) Paired ballast tanks flank the central cargo holds on either side of the vessel
- B) ship cross-sections, showing several possible tank configurations (W = wing tank, DB = double bottom tank)
- C) ballast tank cross-section: on some vessels, staircases and platforms (shaded) present significant obstacles to ballast water sampling beneath manholes and hatches.

2.3 Instrument Deployment Into Tanks

Before lowering an instrument into a hatch or sounding pipe for the first time, always verify that the instrument will have unobstructed passage for the length of the profile. To do this, first lower a “profiling dummy” of length and width no less (and preferably greater) than that of the actual instrument. Note your body position and the position of the cable during lowering because you will want to repeat this precisely with the real instrument. Note the position (depth) whenever you hear clanging noises or feel tugs on the line – these could indicate obstructions that present a real risk of snagging.

If there is a significant risk of snagging the instrument in the ballast tank, abandon the profiling attempt or limit it to the upper portion of the tank, if you know this to be obstruction-free. Alternatively, deploy a back-up instrument that you can afford to lose. Such an instrument should be small, self-contained and lowered on a rope or fishing-wire cable. It should not be connected to a digital display. If you get a backup instrument stuck in the tank, tie it to a ladder so that the crew can retrieve it at a later date, or you may have to cut it loose entirely.

3 Ships and Contaminants

All exchange verification techniques require use of strict protocols in order to minimize the chance of unintentionally contaminating the samples during collection. Ships are inherently biologically and chemically complex environments, in which it is relatively difficult to obtain ‘clean’ samples. For this reason alone, specialized sampling devices which minimize the number of sampling steps and hence the opportunity for contamination are worth developing and should be used if available.

Potential sources of contamination on the vessel include the ship structure and cargo, greases, fuels, dirt and dust (Table 1). Aerosol contaminants may be a significant problem, particularly while the cargo is being shifted and on windy days. At all times, care should be taken to protect samples from aerosol contaminants. Care must also be taken to prevent samples from contacting human skin. Non-talc, surgical gloves should be worn by persons handling CDOM and trace metal samples.

Table 1: Contaminants on Ships. Ships are sources of a variety of contaminants that can contribute error to measurements of the potential verification tracers discussed in the remainder of this document. In the table below, sources of contamination are listed along with the tracers that are likely (Y) or unlikely (N) to be impacted by each contaminant.

Contaminant Source	Potential Verification Tracer		
	Trace Metals	CDOM	Radium
Clean metal structures	Y	N	N
Rust	Y	N	Y
Fuels	Y	Y	N
Aerosols	Y	Y	N
Dust	Y	Y	Y
Sediments	Y	Y	Y
Organic matter	Y	Y	N
Human hands	Y	Y	N

In addition to the contaminants described above, sampling equipment and storage containers can themselves contaminate a sample. The risk of contamination by various materials, in terms of their suitability for trace metals, CDOM and radium sampling, is summarized in Table 2. Note that even where a material is considered suitable, it still needs to be thoroughly cleaned before use. Furthermore, the amount of time a sample stays in contact with any materials other than its storage container, and the number of processing steps, should always be kept at a minimum. Fluorescent materials leaching from new plastic tubing tend to decrease over time, therefore, one should ensure that plastics used for CDOM sampling are both cleaned and well-flushed prior to use.

Table 2: Materials compatibility. The compatibility of a range of materials with tracer (trace metal, CDOM and adium) sampling, in terms of the likelihood that the material will contribute contaminants, are indicated below. Materials are considered suitable (Y), unsuitable (N) or of unknown suitability (-). Materials that should be restricted to short-term exposure applications (e.g. Niskin, pump components, hoses, etc.) rather than prolonged exposure (e.g. sample storage bottles) are further identified by the symbol (*).

Materials	Trace Metals	CDOM	Radium
Synthetics / Plastics			
Nylon	N	Y	Y
Tygon	N	N	Y
HDPE	Y	Y*	Y
Teflon - FEP	Y	Y	Y
Teflon - PTFE	Y*	Y	Y
Polyethylene	Y	Y*	Y
Polycarbonate	Y	Y*	Y
Polysulfone	Y	Y*	Y
Polypropylene	Y	Y*	Y
Polyvinylchloride	N	Y*	Y
Highly colored plastics	N	N	Y
Silicone	Y	N	Y
Buna-N	N	N	Y
Metal			
Stainless steel	N	Y	Y
Titanium	N	Y	Y
Other metals	N	-	-
Glass	N	Y	Y
Pyrex	N	Y	Y
Kimax	N	Y	Y
Vycor	N	Y	Y
Paper cap liners	N	N	Y
Methacrylate	N	-	Y
Rubber	N	N	N
Ultrapure quartz	Y	Y	-
Clean human hands	N	N	-

4 Ballast Water Sampling Apparatus

4.1 Discrete Samplers versus Profiling Instruments

Ballast water samples may be divided into two types – discrete and continuous. Discrete samples are collected from a defined position in the ballast tank at a single point in time. Continuous (or integrated) samples are collected over a longer period of time or over a wider area. Niskin bottles and syringe samplers collect discrete samples from a given location and depth; profiling instruments, such as Hydrolab and YSI multi-probe instruments, collect repeated measurements at programmed intervals while the instrument is mounted in the tank or drawn through the water column. Pumps can be used to collect discrete or integrated samples, depending on the size of the sample and whether samples are drawn from a fixed or changing depth.

Where available, profiling instruments are preferable to discrete samplers, since they give the greatest quantity of data per unit effort, including spatial and/or temporal concentration gradients (e.g. increasing salinity with increasing depth), should these exist. Since profiling instruments are not yet available for most tracers of interest (e.g. trace metals), enough discrete samples should be collected to encompass the range of conditions present in the ballast tanks (e.g. deep and shallow samples).

4.2 Niskin Bottles

Niskin bottles are rigid PVC (polyvinylchloride) tubes, designed to collect a “grab” of water from a discrete depth in the water column (Figure 3). Just prior to deployment, the ends of the tube are arranged to remain open until a catch is released, at which time they snap shut. The bottle is lowered through the water to the desired depth, the catch is triggered (usually by a weight called a “messenger”), and the Niskin bottle is retrieved to the surface. The sample is drained from the Niskin via a small nozzle.

Niskin bottles are available in a range of sizes. For the purposes of sampling ballast water, a Niskin bottle of volume 1.7 L (full weight ~ 9 lb) should be sufficiently large to collect enough water for several samples. Niskin bottles are suited to CDOM sampling, but may be



Figure 3: Niskin bottle sampler.

difficult to keep clean of trace metals. Other methods are better suited for sampling for radium due to the large volume required.

4.3 Syringe Samplers

A messenger-activated syringe sampler (Figure 4) can be used to collect small volume (~ 60 mL) discrete samples. The sampler is lowered into the tank and the messenger activated, causing water to be drawn into a disposable plastic or reusable glass syringe. The syringe is removable as one unit for simple transfer or storage.

The principal advantage of syringe samplers is that contamination risk is reduced due to the decreased number of handling steps and decreased area of apparatus exposed to the sample. Moreover, samples can be taken through openings as small as two inches. Plastic syringe samplers are particularly suited to trace metal sampling, which requires only about 10 mL filtered sample per replicate.



Figure 4: Syringe sampler.

4.4 Pumps

Pumps are highly suited to intensive ballast sampling operations. Such operations may necessitate repeated sampling in a tank, access to regions of tanks that are not normally accessible from deck, and/or the collection of a large volume of water impractical to obtain by other methods. In selecting a pump, important considerations include the type of materials in the pump in contact with the fluid, distance from the pump to the water level, and the power supply.

4.4.1 Power Supply

Pumps suited to ballast tank sampling are typically powered by gas, electricity, batteries or air. Air driven pumps are intrinsically safe - a feature that is required on some types of vessel (e.g. oil tankers). They are also relatively flexible in that they are inexpensive and most ships have air available on deck. Disadvantages of air-driven pumps are that air supply outlets on deck may be far from the sampling location, and air hoses are long, heavy, unwieldy, and may be in short supply. Electrical pumps often require use of transformers and adaptors because electricity supplies vary greatly across ships. Gas and battery-powered pumps may be suitable for ballast water sampling, although due to the risk of sparking, they are not usually permitted on ships with flammable cargo or in confined spaces.

4.4.2 Capacity

Pumps can be purchased that are capable of delivering the full spectrum of flow rates from milliliters to gallons per minute. A low capacity pump (flow rate 0.3 – 3 gal/min) was found to be suitable for radium, trace metal and CDOM sampling, since sample collection requires low flow rates. If the intention is to collect or store large volumes of ballast water, it is advisable to also have available a pump capable of higher flow rates.

4.4.3 Performance

The performance of a pump is a function of both its capacity and how much work is required to lift the water from the ballast tank to the deck. This depends upon the distance between the surface of the water and the outlet of the pump tubing (head), and how much of that distance the water must travel under suction (suction lift) versus the distance the water is pushed by the pump (dynamic head). Pumps operating from deck are limited by their suction lift capacity, which typically varies from just a few feet to a few meters. This renders them unsuitable for deck sampling of partially full or double-bottom tanks. Submersible pumps push water from the submerged pump head rather than lift to the head. They are often capable of elevating water to much greater heights than lift pumps and are better suited to sampling in these situations.

4.4.4 Materials

Pumps, hoses and fittings can be obtained with all-plastic parts, all-metal parts or a combination of metal and plastic parts. Plastic pumps are recommended for collection of radium and trace metal samples. Plastic pumps can be also used to collect CDOM samples providing that the plastic does not leach significant quantities of fluorescent compounds. In diaphragm pumps, internal parts (e.g. diaphragms) may be made of a range of materials, including rubber derivatives (not recommended), Teflon® (suitable but very expensive), and Wil-flex® (lower cost alternative to Teflon). Since plastic products are being developed continually and manufacturers vary in their choices of materials, the suitability of any given pump for CDOM or trace metal work may be difficult to predict. The best way to address this uncertainty is to test products in the laboratory prior to use, and collect blanks as well as ballast water samples (Section 5.6).

4.4.5 Air Hose Couplings

Air supply lines that can be used to power air-driven pumps are generally found at regular intervals on deck, typically between or alongside cargo holds. Each ship usually uses a single type of air-hose coupling on deck; however, different ships may favor different types of couplings. If the coupling type is unknown prior

to boarding a vessel, a variety of connector and adapters should be carried on board to allow access to air supplies under all potential scenarios. Examples are shown in Figure 5.

Note that air pressure on deck may be less than a pump's required rating, which can cause the pump to operate at lower flow rates than specified in technical data sheets.

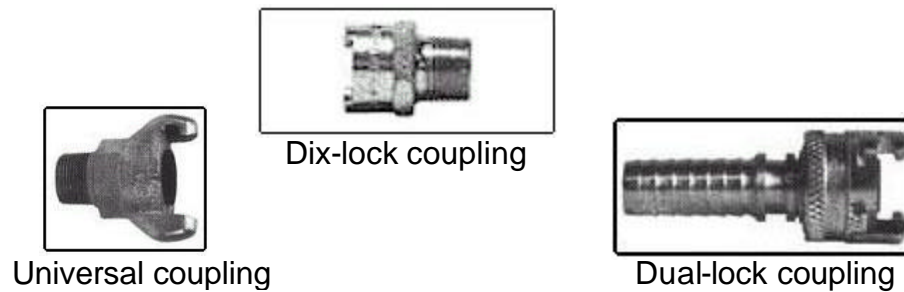

Figure 5: Types of air hose couplings commonly encountered on ships.

5 Ballast Water Sampling Protocols

5.1 Diaphragm Pump Configuration

5.1.1 Overview

As an example for obtaining samples, this section describes the configuration and operation of an air-driven diaphragm pump (Wilden Pro-flo, P.025) used extensively by Murphy *et al.* (2001) for ballast water sampling. Trace metal, CDOM and radium protocols were implemented by connecting the appropriate appendages to the outlet hose of the pump, as described in Sections 5.3.2 - 5.5.2. The pump outlet hose terminates at “C” in Figure 6.

5.1.2 Equipment Specifications

- Air filter / regulator
Example: Master / pneumatic filter-regulator (CFR55-1-E5)
- Diaphragm pump
high capacity (flow rate > 10 gal/ min)
Example: Wilden Pro-flo P.05 Air operated 1/2” double diaphragm pump
low capacity (flow rate 1-2 L / min)
Example: Wilden Pro-flo P.025 Air operated 1/4” double diaphragm pump
- Pulsation dampner (optional) - for smoothing pulses in the flow.

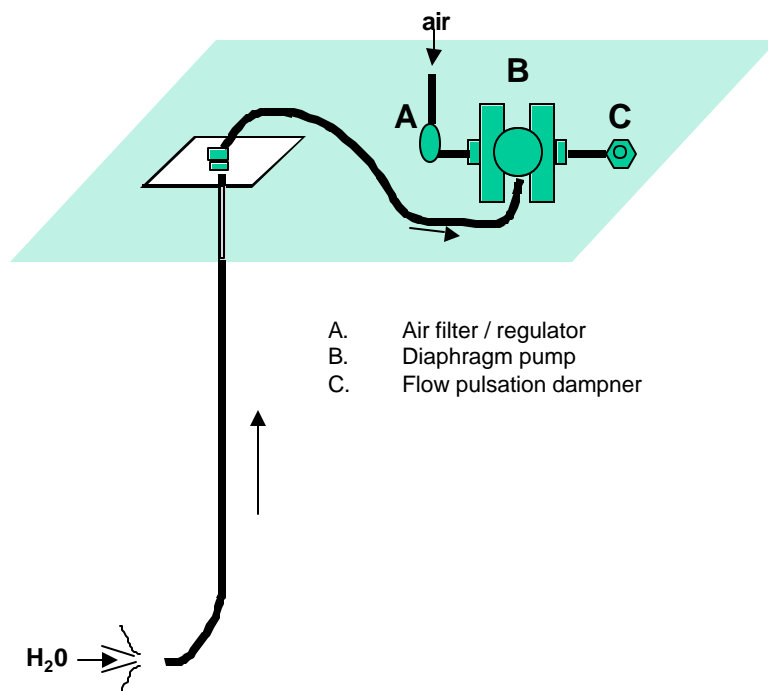

Figure 6: Diaphragm pump set-up for ballast water sampling.

5.2 Salinity Sampling Protocol

5.2.1 Overview

Mid-ocean salinities are generally stable and well defined. In the North Atlantic, surface ocean salinities are typically around 35-36 parts per thousand (ppt). They are slightly lower in the North Pacific (32-33 ppt). In contrast, many coastal ports are characterized by fresh (< 0.5 ppt) or brackish water (0.5 -17 ppt).

While many ports are less salty than the open ocean, coastal regions with little river or rain input can exhibit salinities similar to in the open ocean. It is for this reason that salinity measurements alone are insufficient for verifying mid-ocean ballast water exchange. However, since salinity measurements are simple to perform and may quickly reveal the contents of a ballast tank to be fresh or brackish coastal water, they are a critical part of any ballast water sampling program.

5.2.2 Sampling Apparatus

Salinity can be measured conveniently in real-time using a variety of readily available instruments designed for profiling applications. Many such instruments combine salinity measurement with other water data including depth, temperature, pH and dissolved oxygen (DO).

The use of multi-probe instruments capable of measuring dissolved oxygen is recommended, since oxygen measurements may assist in the interpretation of CDOM and trace metal data. To minimize the risk of getting any instrument caught in the tank, ensure that it is of streamlined design and symmetrical around the rope or cable used to lower it. Two examples of suitable salinity meters (salinometers) are as follows:

- **YSI Environmental DO, Conductivity, Salinity, Temperature Instrument (YSI-85)**

This instrument measures dissolved oxygen, conductivity, salinity and temperature simultaneously. A sensor on the end of a cable (10 – 100 feet) is lowered into the water while the operator reads the measurements from a handheld digital display. This instrument is easily handled and suitable for profiling applications.

- **Hydrolab Minisonde 4a Water Quality Multiprobe**

This programmable instrument measures depth, dissolved oxygen, conductivity, salinity and temperature at pre-programmed intervals and logs the results in a data file that can be later downloaded to a computer. A digital readout option can be purchased for real-time data display. This instrument is suitable for profiling and long-term monitoring applications.

Instruments should always be calibrated using manufacturer's recommendations prior to use. Calibration checks should be done following each use.

5.2.3 Procedure

To take measurements using a salinity-profiling instrument (SPI), first mark 1-m increments on the cable, then:

- Lower the SPI until the sensors are 1 meter below the water surface. Record depth, salinity, and other sensor readings (e.g. DO, pH, etc.).
- Lower the SPI until it just touches the bottom of the tank, or the bottom of the intended profiling region as determined by the "profiling dummy." Record depth, salinity, and other sensor readings.
- If the salinity varies by LESS THAN 1 ppt (or 1 practical salinity unit [psu]) between the top and bottom of the tank, begin raising the SPI, stopping to take further readings at ~ 5 m intervals.
- If the salinity varies by MORE THAN 1 ppt (or 1 psu) between the top and bottom of the tank, begin raising the SPI, stopping to take further readings at ~ 2 m intervals.
- If an abrupt change between two consecutive readings is noticed (readings differ by more than 10 percent), lower the SPI by 1 meter and take readings there also. Note the approximate depth at which the abrupt change occurs – this indicates that there is more than one distinct water mass in the tank (i.e., the tank is stratified). Any discrete samples should be taken from each water mass in a stratified ballast tank.

5.3 Trace Metal Sampling Protocol

5.3.1 Overview

Many metals exhibit pronounced onshore-offshore concentration gradients which reflect their terrestrial origin. Metals enter waterways after leaching naturally from rocks and soil, or in elevated concentrations associated with industrial sources. Particularly common in nearshore waters are the constituents of steel, brass and bronze (iron (Fe), nickel (Ni), zinc (Zn), copper (Cu), aluminum (Al)). In localized regions, high concentrations of silver (Ag) in seawater are found in association with sewage outfalls and the jewelry industry. Main coastal sources for Manganese (Mn), Barium (Ba) and Thorium (Th) are riverine inputs (desorption from minerals), groundwater input (seepage through sediments) and atmospheric deposition of dust.

Trace metal samples are extremely easy to contaminate, consequently, all sampling materials and apparatus should be left sealed in plastic bags until needed, handled as cleanly as possible and returned to sealed bags after use. One person in the sampling party should be designated as “clean hands”. This person only touches “clean” surfaces such as the plastic bags, open ends of pump tubing and sample centrifuge tubes. The designated “dirty hands” handles all other equipment that “clean hands” cannot touch (any metal objects, anything that has come into contact with metal surfaces).

It is imperative that the open ends of the pump tubing (inlet and outlet) remain as clean as possible. Whenever the tubing connected to the pump is not submerged in the ballast tank it should be bagged up such that the system (tubing and pump) is closed to the outside environment. Immediately prior to sampling, the plastic covering the open ends of the tubing should be removed and the tubing lowered into the tank. Utmost care should be taken to avoid brushing the inlet or outlet against the deck or the walls of the ballast tank. Similarly, do not allow the outer surfaces of syringes or hoses to come into contact with the inside of the sample bottles.

5.3.2 Sampling Apparatus

To obtain trace metal samples by pump, the pump apparatus of Figure 6 should be connected to the apparatus of Figure 7. To obtain trace metal samples by Niskin bottle, ballast water should be drained from the Niskin into the filter syringe, then injected into the sample tubes.

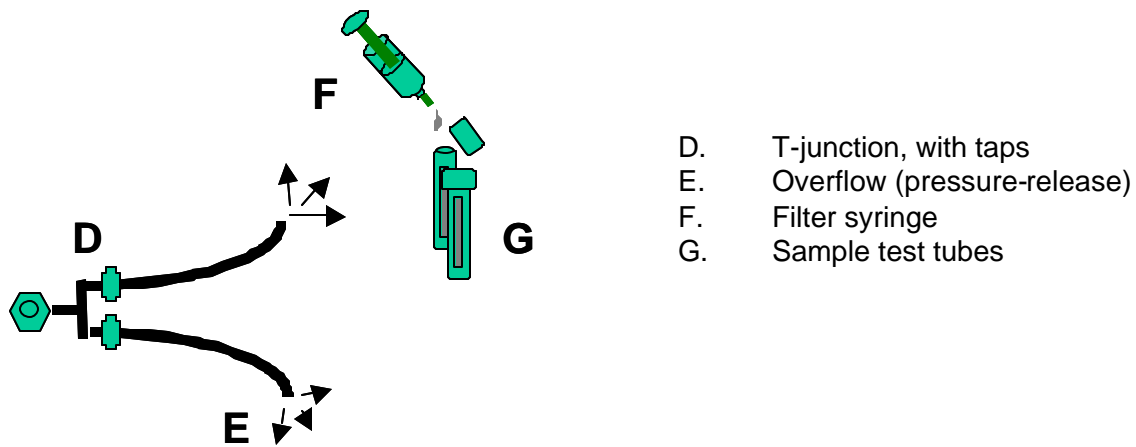

Figure 7: Trace metal pump sampling apparatus.

5.3.3 Equipment Specifications

- Disposable syringe
Example: 20 mL polypropylene syringes (Fisher Scientific: NC 9374 494).
- Syringe Filters (45 μm)
Example: 25 mm syringe filters with 45 μm supor membranes (Fisher Scientific: 09-731-124).
- Sample Tubes: HDPE conical bottom centrifuge tubes
Example: 50 mL polypropylene centrifuge tubes (Fisher Scientific: 05-538-55).

5.3.4 Products

The objective is to obtain ~10 mL of filtered ballast water in each sample bottle (test tube), according to strict cleanliness protocols. Two replicate samples of 10 mL each should be taken at each site. Following collection, the samples are frozen then shipped to the laboratory for ICP-MS analysis.

5.3.5 Procedure

5.3.5.1 Preparation of sampling apparatus

Before setting out for the ship, ensure that any materials that will come in contact with the water sample (i.e. pumps, hoses, syringes, filters and sample bottles) are trace-metal clean, and protected from the elements inside fresh zip-lock plastic bags. Cleaning is performed onshore in specially

designed laboratories by soaking materials in 1 mol L⁻¹ HCl (reagent grade, hydrochloric acid) at 60 °C for at least 24 h prior to use. Following acid leaches all materials should be rinsed thoroughly (5 times) with distilled, deionized water and left to dry in a Class 100 laminar flow bench.

The cleanliness of the sampling apparatus (at least in regard to the metals of interest, e.g. Ba, Mn, P (phosphorus), U (uranium), V (vanadium) should be verified prior to sampling using the sample blank procedure described in Section 5.6.

5.3.5.2 Shipboard Sampling

Collection of trace metal samples requires extremely careful handling to prevent contamination of the samples. The procedure described below and summarized in Table 3 requires two people. The first person (A) should concentrate on operating the pump and passing supplies to the other person (B), who will be responsible for handling filtration apparatus and sample bottles. Person B should wear two pairs of non-talc, latex gloves on deck. Immediately before handling the syringe or opening the sample test tube, Person B should discard the outer pair of gloves.

1. Collect trace metal blanks according to the procedure of Section 5.6.
2. Collect trace metal samples according to the procedure of Table 3.
3. Affix a label to the sample test tube, and write the sample ID number directly on the test tube using a permanent marker.
4. Seal sample bottles with Parafilm® and place samples in individual zip-lock bags. Place bagged samples together inside a larger plastic bag. Note that the Parafilm® does not come in contact with the sample. It prevents the caps from working loose during handling.
5. Fill out the sample log. Be sure to note any problems experienced while collecting the sample, in particular, bad weather conditions (wind or rain).
6. Carefully retrieve sample hoses, cap their ends with Parafilm ® and place the hoses in clearly marked zip-lock bags. The Parafilm® seals the ends of the hoses to protect the hose interior from contamination.

7. In order to prevent bacterial alteration of the sample, freeze samples as soon as possible after sampling. If freezing must be delayed, keep samples as cold as possible until they can be frozen. For example, maintaining samples on ice while sampling on deck is appropriate. Transport to laboratory.

Table 3: Trace metal sampling procedure – 2-person protocol.

Person A: “Dirty Hands”	Person B: “Clean Hands”
<ol style="list-style-type: none"> 1. Connect the pump inlet hose to pre-installed hoses in the ballast tank, or otherwise to the desired sampling location. Connect the pump to the power supply. Use apparatus arrangement of Figure 6 and Figure 7. 2. Turn on the pump and flush ballast water through the sampling system for 5 minutes. Make sure you flush both sides of the T-junction, and then adjust the taps until you have a steady trickle through the hose end you will take the sample from. 	<ol style="list-style-type: none"> 1. Before going out on deck, don two pairs of non-talc, latex surgical gloves. 2. Avoid contact with unclean surfaces as much as possible. The outer pair of gloves keeps the inner pair clean until sampling actually begins.
<ol style="list-style-type: none"> 3. Assist Person B. While you can handle the bags containing sampling accessories, do not touch the interior bags, syringe, filters or test tubes. 	<ol style="list-style-type: none"> 3. Remove and discard your outer pair of gloves. Carefully remove an unused syringe barrel from its zip-lock bag, and with Person A controlling the hose, rinse it with ballast water, then shake off excess water, holding the plunger-end down to prevent any water on your hands from running to the tip. 4. Without removing the filter from its zip-lock bag, screw the filter on to the end of the syringe. Remove the filter (now attached to the syringe) from the bag, invert the syringe barrel, and fill it with ballast water. 5. Insert the plunger in the end of the syringe. Gently push approximately 1 mL of ballast water through the syringe. Discard this water. 6. Without touching the inside of either the test tube or its lid, carefully remove the lid from the sampling test tube. Hand the bottom of the test tube to Person A to hold.
<ol style="list-style-type: none"> 4. Hold the bottom of the test tube while Person B injects the sample. Afterwards, allow Person B to screw on the cap. 	<ol style="list-style-type: none"> 7. Inject ~ 10 mL of sample into the test tube and carefully replace the cap, screwing it tightly closed. Repeat for second sample.
<ol style="list-style-type: none"> 5. Label the sample. Place sample in a zip-lock plastic bag. When all samples are collected, waterproof the seals on the sample bottles 	<ol style="list-style-type: none"> 8. Repeat steps 2-6 for all further samples.

with parafilm, then pack them upright in an ice-packed cooler.	
--	--

5.3.6 *Sample Log*

Table 4 shows an example logbook entry for two hypothetical samples. All fields must be filled out each time a sample is collected.

Table 4: Example logbook entries for trace metal samples.

Sample ID-No.	Method	Date	Depth	Filter	Blank Id-No.	Notes
Met-511	Syringe	1/Jan/03	1 m	0.22 µm	B1-0353-11	As per protocols
Met-512	Pump	1/Jan/03	10 m	0.22 µm	B1-0353-12	Heavy sediment noted

5.3.7 *Sample Delivery to Analytical Laboratories*

Trace metal samples should be frozen to prevent microbial activity that may alter the chemistry of the sample. If it is not possible to freeze the samples, they should be kept cool or on ice until they arrive at the laboratory. Frozen samples will not expire, so these may be accumulated and shipped to the laboratory in bulk.

5.4 Colored Dissolved Organic Matter (CDOM) Sampling Protocol

5.4.1 *Overview*

Fluorescence of colored dissolved organic matter (CDOM) has been used as a sensitive and specific tracer of natural and anthropogenic compounds in the environment for many years. Rivers are the major source of natural CDOM to the oceans; CDOM can vary two orders of magnitude along a 0 - 35 ppt salinity gradient where a river enters the ocean. In addition to large changes in intensity, spectral properties also vary with organic matter source and type. Riverine and marine samples can be distinguished on the basis of CDOM as can contributions from petroleum hydrocarbons, microbial growth, and other specific sources.

Fluorescence can be measured in-situ using field fluorometers or with more complex lab-based instrumentation. While the goal is to eventually measure CDOM in ballast tanks using in-situ profiling instruments, the best possible configuration of such instruments is yet to be determined. Since laboratory equipment is currently able to perform more intensive CDOM analyses than in-situ instruments, collection

of discrete samples for laboratory analysis is advocated at this time. This will help inform the development of in-situ instrumentation.

Even though plastic can be used to collect CDOM samples, plastic contains carbon and is a potential source of contamination. Glass fiber filters are commonly used to filter CDOM samples from coastal environments. However these are also a potential source of low level CDOM contamination and should be flushed with ~ 1 liter of ballast water prior to collecting samples. Thus at least 1.1 L of ballast water should be passed through the filter.

5.4.2 *In-situ CDOM Fluorometers*

Instrumentation and protocols for in-situ CDOM measurements are still to be established. A generalized protocol follows:

- Calibrate and optimize field instrument for detection of CDOM.
- Measure the CDOM profile in the ballast tank in a manner similar to that described for salinity.
- Determine compliance by comparing output with pre-determined standards.

5.4.3 *Sampling Apparatus*

To obtain CDOM samples for laboratory analysis, the pump apparatus of Figure 6 should be connected to the apparatus of Figure 8.

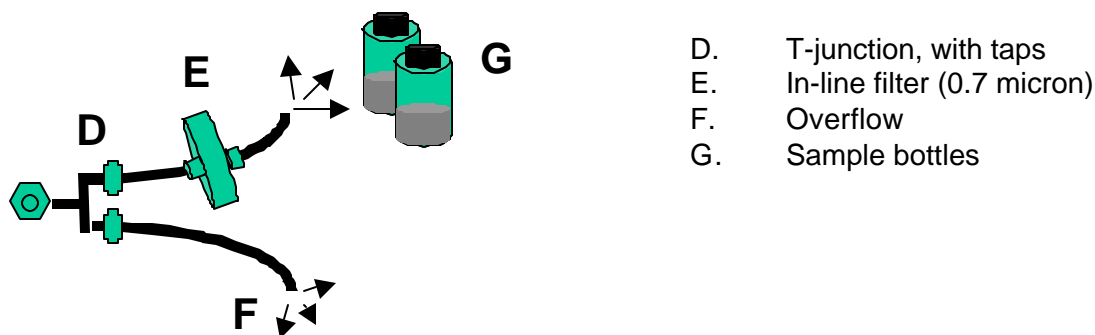

Figure 8: CDOM pump sampling apparatus.

5.4.4 *Equipment Specifications*

- In-line filter holder

Example: 47 mm in-line filter holder (Nalgene 09-740-37A – Fisher Scientific)

- Filter: ~ 0.7 μm

Example: Whatman GF/F (~ 0.7 μm) filters (Fisher Scientific: 09-874-71)

- Cleaned 120 mL amber glass storage bottles with teflon lined caps

Example: 120 mL Amber Boston Round (Fisher Scientific: 03-320-4B)

5.4.5 Products

The objective is to obtain ~ 100 mL of filtered ballast water in each sample bottle, according to strict cleanliness protocols. During sampling events, samples may be stored on ice. Following collection, the samples are frozen as soon as possible and then shipped to the laboratory for analysis by Emission Excitation Matrix Spectroscopy (EEMS).

5.4.6 Procedure

5.4.6.1 Preparation of Sampling Apparatus

Any materials that will come in contact with the sample (i.e. pumps, hoses, syringes, filters and sample containers) must be clean of grease, organic matter and other fluorescent materials. Prior to setting out for the ship, cleaning should be performed in the laboratory as follows:

Glass Fiber Filters:

- Bake at 400 °C for 5-12 hours, then pack in aluminum foil inside zip-lock bags.

Glass Sample Bottles (120 – 150 mL, caps removed):

- Wash with glassware detergent.
- Rinse 2 times with tap water, to remove detergent.
- Rinse 3 times with distilled, deionized water (e.g. Milli-Q).
- Bake bottles at 450 °C for 8-24 hours.

Teflon Bottle Caps:

- Rinse 2 times with MilliQ water (do not soak).
- Rinse 1 time with HPLC grade methanol (do not soak).
- Dry in 30-35 °C oven until methanol evaporates (~ 1 hour).

The cleanliness of the sampling apparatus should be verified prior to sampling using the sample blank procedure described in Section 5.6.

5.4.6.2 Shipboard Sampling

Connect the pump inlet hose to pre-installed hoses in the ballast tank, or otherwise to the desired sampling location. Connect the pump to the power supply. Use apparatus arrangement of Figure 6 and Figure 8.

- Before turning on the pump, make sure that the tap immediately prior to the in-line filter is in the “off” position while the other tap is in the “on” position. This will prevent the filter paper from rupturing when the water begins to flow.
- Collect CDOM blanks according to the procedure of Section 5.6 after flushing the filter and filter apparatus with approximately 1 L of milli-Q water.
- Turn on the pump and flush ballast water through the sampling system for 5 minutes per location. This ensures that undiluted ballast water reaches the filter apparatus. Then adjust the taps until a slow trickle ($\sim 60 \text{ mL min}^{-1}$) of water emerges through the filter.
- The GFF should be rinsed with 1 L of ballast water before the sample is taken. Depending on the dirty the ballast water is, discard the first 30-50 mL of water emerging through the filter. Use the next 20 mL to rinse the sample bottle.
- Taking care not to touch the inside of the cap, fill the sample bottle with filtered ballast water leaving sufficient headspace, i.e., to the beginning of the shoulder. Do not overfill the bottle, or else it may break during freezing.
- Store samples in light-proof Styrofoam™ boxes, freeze, and ship them to laboratory according to instructions in Section 5.4.8.

5.4.7 Sample Log

Table 5 shows an example logbook entry for two hypothetical samples. All fields should be filled out each time a sample is collected and problems noted.

Table 5: Example logbook entries for CDOM samples.

ID-No.	Method	Date	Depth	Filtered?	Blank Id-No.	Notes
CDOM-611	Pump	1/Jan/03	1 m	yes	Bl-0363-11	As per protocols
CDOM-612	Niskin	1/Jan/03	10 m	yes	Bl-0363-12	As per protocols; Niskin touched ladder

5.4.8 Sample Delivery to Analytical Laboratories

Samples should be stored in lightproof Styrofoam™ boxes, with sufficient padding to prevent breakage. If the samples will be analyzed in the next 24 hours, the samples may be refrigerated and shipped (express) to the laboratory responsible for their analysis. If they will not be analyzed in a 24 hour time frame, they must be immediately frozen. Frozen samples must be packed in a way that will ensure that they do not thaw in transit. To prevent their arrival while the laboratory is unattended, frozen samples should be shipped overnight in the early part of the week.

5.5 Radium Sampling Protocol

5.5.1 Overview

Two types of samples (short- and long-lived isotopes) are used to fully characterize radium (Ra) in seawater. Because of the large volume of water required for collection of samples for analysis of long-lived isotopes, extraction of radium onto filters is easiest performed on deck using a pump. In the interests of efficiency, the pumping system should be organized such that the two types of samples are collected simultaneously:

1. Long-lived isotopes and Activity Ratios: ^{226}Ra and ^{228}Ra
2. Short-lived isotopes: ^{223}Ra and ^{224}Ra

For research purposes, it may not be necessary for an operator to be present during the entire pumping process provided that the pump is appropriately secured and automated. Refer to operational requirements if these samples are being taken for enforcement purposes.

5.5.2 Sampling Apparatus

To obtain radium samples by pumping directly from the ballast tanks, the pump apparatus of Figure 6 should be connected to the apparatus of Figure 9.

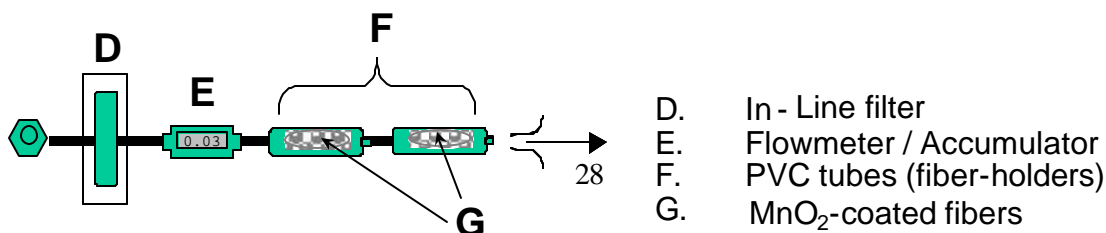

Figure 9: Radium Pump Sampling Apparatus.

5.5.3 Equipment Specifications

- In-line pre-filter:
Example: Cole-Parmer Polycarbonate inline filter holder (29828-00) with spun polypropylene filter (01509-15)
- Volume Measurement
 - Flow meter / accumulator,
Example: Cole-Parmer Electronic Flowmeter/Accumulator (05610-60)
 - or a 55-gallon plastic drum for volume standardization, and a 2-gallon plastic carboy for flow rate standardization
- PVC tube (fiber holder):
Assembled in the laboratory of W.S. Moore from readily-available parts.
- MnO₂-coated fiber:
Magnesium-oxide coated fibers, produced in the laboratory of W.S. Moore or by using a published procedure (Moore 1973, 1976).

5.5.4 Products

Each ballast water-soaked MnO₂-coated fiber constitutes a sample. These are stored in separate zip-lock bags and shipped to the laboratory for analysis. The effluent through these cartridges is not part of the sample.

5.5.5 Procedure

Preparation of MnO₂-coated fibers

- Obtain MnO₂-coated fibers (Mn-fiber) from an approved source or prepare according to published procedure. Fibers are stored in individual zip-lock bags.

5.5.5.1 Control of Volumes and Flow Rates:

The control of volumes and flow rates can be done in several ways. The crucial point is to construct a system that allows a known quantity of filtered ballast water to flow through the MnO₂-coated fiber at a relatively constant low flow rate (1-4 L min⁻¹).

A very simple system might involve pumping the ballast water via a filter into a large drum (at least 55 gallon). Prior to initial use of the drum or carboy, accurately determine the volume of the container and mark that volume on the container. For example, fill the container with a known volume of water and mark the level; thereafter, fill to the same level each time. While the drum is being drained (by pump or under gravity), the flow rate is determined by measuring the time taken to fill a 2 gallon carboy with the effluent.

A more sophisticated system could involve pumping directly from the ballast tank through a flow meter/accumulator that records the flow rate at any instant and the total volume through the meter in that session. In this case, the need for the drum and carboy would be eliminated.

5.5.5.2 Ship-board sampling

A system for pumping directly from the tank using a flow meter/accumulator is described below. It can be readily adapted for the alternative case where ballast water is pumped or drained from a drum, using the drum and carboy in place of the flow meter.

1. Connect the pump inlet hose to pre-installed hoses in the ballast tank, or otherwise to the desired sampling location. Connect the pump to the power supply. Use the apparatus arrangement of Figure 6 and Figure 9.
2. Turn on the pump and flush ballast water through the sampling system water line for 5 minutes.
3. Turn off pump and set flowmeter / accumulator volume to zero.
4. Place a clean, dry MnO₂-coated fiber cartridge in each sample column. Connect these in series to the source of filtered ballast water.
5. Turn on pump. Adjust the air supply until the flow rate through the sample column is between 3 - 4 L min⁻¹.

6. Pump no less than 55 gallons of ballast water through the filter column, then shut off the pump and remove the Mn-fiber cartridges. (More is better, but the volume pumped must be known.) Place the first MnO₂-coated fiber cartridge in a zip-lock bag, squeeze both cartridge and bag to expel excess water, and then pour out excess water and seal the bag. Label the bag, identifying that the sample is from the first column of the series. Place the second MnO₂-coated fiber cartridge in a different zip-lock bag, squeeze out the excess water, and then label the bag identifying the sample as that from the rear column of the series. Place each pair of bags in a single, larger bag that is clearly labeled with information identifying sample site and time.
7. Write the Sample ID, type, volume and date on the zip-lock bag in indelible ink.
8. Fill out the sample log. Be sure to note the accumulated volume displayed by the flow meter (alternatively, record the known volume of the drum).

5.5.6 Sample Log

Table 6 shows an example logbook entry for two hypothetical samples. All fields must be filled out each time a sample is collected.

Table 6: Example logbook entries for radium samples.

ID-No.	Type	Depth	Date	Pump Rate	Collection time		Volume (liters)	
					Start	Stop	Measured	Flow Meter
Ra-123	Radium	1 m	1/Jan/03	3.7 L min ⁻¹	0800	0900	-	199.5
Ra-124	Radium	10 m	1/Jan/03	3.5 L min ⁻¹	1000	1100	206.4	-

5.5.7 Sample Delivery to Analytical Laboratories

Radium samples are time-sensitive and must be analyzed as soon as possible after collection; therefore consideration should be given as to appropriate times to collect samples and samples should be shipped to the laboratory as soon as possible. (For example, the 3.7-day half-life of ²²⁴Ra means that concentrations in samples taken at the beginning of a long voyage will be only a small percentage of their initial value when analyzed.) At the end of the voyage, all samples, together with copies of log sheets, should be shipped overnight in a padded envelope to the processing laboratory. Radium samples are not hazardous and do not require any other special handling such as freezing, chilling, or dark atmosphere. For mailing purposes, they can be described on the package as ‘scientific samples’.

5.6 Blank Sampling Protocol

5.6.1 Overview

Sample “blanks” are used to account for contamination introduced during the sampling process. They play an important role in quality control, particularly in the case of easily contaminated tracers, such as metals and CDOM. Blanks are necessary if there is a risk that samples will be exposed to contaminants affecting their chemical composition as a result of being removed from their original environment. For example, in the case of ballast water sampling, a contaminated trace metal sample will have higher metal concentrations than does the water in the ballast tank. This may lead to a situation in which a vessel that underwent mid-ocean exchange appears not to have done so.

Contaminants due to the sampling process are quantified by subjecting an ultra clean solution, known to

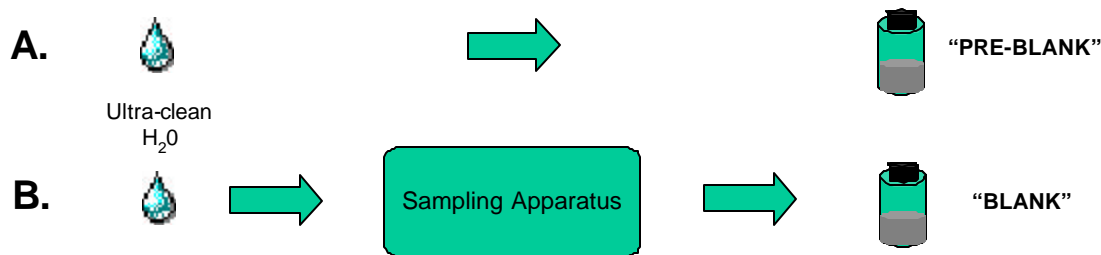

have very low levels of contaminants, to the same sampling procedure as the ballast water samples. The levels of contaminants measured in these “blank” samples are then used to define a baseline that is subtracted from the levels measured in the ballast water samples. This provides verification that tracers measured in ballast water samples originated in the ballast tanks rather than in the sampling apparatus.

Blank samples require ultra-clean water, such as water treated under a Milli-Q® system, which has been stored in specially prepared containers. If there is any doubt that the ultra-clean water is not ultra-clean prior to sampling, a sample of the ultra-clean water should be collected (“pre-blank”, Figure 10A). This allows unintended contaminants in the ultra-clean water to be subtracted from the blank measurements (Figure 10B).

Figure 10: Conceptual diagram of pre-blank and blank samples.

5.6.2 *Sampling Apparatus*

Sampling apparatus and specifications are identical to that required for ballast water sampling for either trace metal or CDOM tracers (Sections 5.3.2 and 5.4.3 respectively).

In addition to the usual sampling equipment, a reliable supply of ultra-clean water is required. This water should be stored in containers made of plastic (trace metal blanks) or glass (CDOM blanks). Containers should have internal tubing and/or spigots so that it is possible to extract the water without inserting any objects (e.g. pump tubing) that may have unclean surfaces.

5.6.3 *Products*

The objective is to obtain samples of filtered ultra-clean water, according to the same protocols used to collect ballast water samples. Following collection, the samples are shipped along with the ballast water samples to the appropriate analytical laboratory for analysis.

5.6.4 *Procedure.*

- Sample blanks should be taken on deck immediately prior to initial ballast water sampling.
- Collect two (2) replicate pre-blank samples, if required. If all sampling gear is sealed and protected between sampling events and if the ultra-clean water remains uncontaminated, additional blanks are not required at each event.
- Flush sampling apparatus with at least three volumes of ultra-clean water (30 mL for CDOM, 20 mL for trace metals). Ideally, the apparatus and filter should be flushed with at least 1 L of ultra-clean water before the blank is taken.
- Collect two (2) replicate blank samples for each analysis type (trace metals or CDOM). Take care to seal and protect pump hoses, filter apparatus, etc after collecting blanks.
- If samples are to be frozen, take particular care not to overfill sample bottles since pure water expands more than does seawater when frozen (Figure 11). Lay bottles on their side while freezing to reduce the chance of breakages.

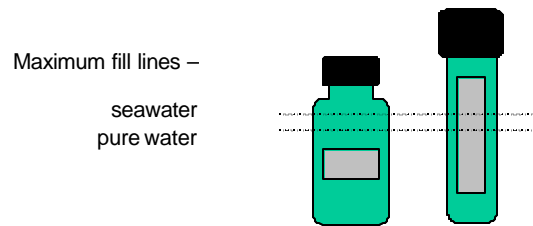

Figure 11: Preventing CDOM and trace metal bottle breakages during freezing.

5.7 Ship-side Sampling Protocol

5.7.1 Overview

While a ship is sailing, it is possible to obtain samples of ambient water by accessing the engine cooling pipe system. Water is circulated constantly from the outside of the vessel, through the engine cooling system and out again. The system should be accessed as near as possible to the point of entry of the seawater, i.e., near the sea-chest in the engine room. A less-convenient alternative is to obtain samples on deck via a fire hose, which also taps water from originating from outside of the ship. Accessing pipes in the engineroom is preferable, since seawater is ejected from fire hoses at high pressure, requiring a separate collection step to obtain water which can be subsequently filtered according to normal protocols.

5.7.2 Procedure

5.7.2.1 Fire hose

- Confirm that the fire hose is supplied with clean, untreated ambient water.
- Stabilize the fire hose by tying it to the railing of the ship.
- Ask a crew member to flush the hose for at least 30 minutes.
- Measure and record salinity and temperature of water supplied by the hose.
- CDOM: Fill a clean amber glass container with water from the hose.
- Trace Metals: Fill a clean plastic container with water from the hose.

- Radium: Fill a clean plastic 55-gallon drum with water from the hose.
- Follow same filtration steps as for ballast tank samples.
- Apply normal trace metal, CDOM or radium protocols to the containers of ambient water.

5.7.2.2 Engine Room

- Ask a ship's engineer to direct you to a tap which accesses clean, untreated ambient water.
- Flush ~ 4 gallons of water through the tap, collecting the waste in a bucket.
- Adjust the flow from the tap to a trickle so that trace metal and CDOM filtration can be performed under low pressure.
- Measure and record salinity and temperature.
- Trace Metals: Filter water directly from the tap, then proceed according to the protocols of Section 5.3.
- CDOM: Filter water directly from the tap, then proceed according to the protocols of Section 5.4.
- Radium: Fill a clean plastic 55-gallon drum with water from the hose, then filter the stored water according to the protocols of Section 5.5.

6 Conclusions and Recommendations

The primary intent of the protocols in this document is to provide a basis for sampling CDOM, trace metals and radium products from ships' ballast tanks. Important considerations include the following:

- Ships have significant contamination problems that must be minimized during sampling for all parameters.
- Sampling and storage equipment must be chosen wisely to avoid further contamination.
- Cooling and freezing capabilities must be available for sample preservation.
- Sounding tubes may not provide samples representative of tank contents.
- Access to tanks varies widely; hatch and manway access may not be available in some cases.
- Profiling instruments provide rapid assessment of tank stratification, but significant potential exists to lose the instrument by tangling it on structures within the tank.
- Pumps can sample water at depth, but power requirements, lift capacity, internal materials, and delivery rates must be considered during pump selection.
- Trace metal samples are highly susceptible to contamination from multiple sources; samples should be taken and handled carefully with contamination issues in mind.

- CDOM samples will generate approximately 1 L of rinse water per sample that must be contained and disposed of.
- Radium sampling requires large volumes (~ 55 gallons) and is probably unsuitable for Coast Guard sampling for enforcement due to the time, volume, and equipment required.
- Blanks are necessary for each parameter. High quality water must be available for blanks.

The detailed information provided in the protocols should enable researchers to collect data compatible with that already residing in a database at the Smithsonian Environmental Research Center. Such additional data will enhance the capability to discriminate between open ocean and coastal water.

Significant modifications to these protocols will be required before they can be used for Coast Guard's enforcement operations.

7 References

Dodgshun, T., and Handley, S., 1997. *Sampling Ships' Ballast Water - A Practical Manual*. Cawthron Report No. 418, Nelson.

Moore, W.S. and Reid, D.F., 1973 Extraction of radium from natural waters using manganese-impregnated acrylic fibers, *Journal of Geophysical Research*, 78 (36), 8880-8886.

Moore W.S., 1976. Sampling ^{228}Ra in the deep ocean. *Deep-Sea Research*, 23, 647-651.

Murphy, K., Coble, P., Boehme, J., Field, P., Cullen, J., Perry, E., Moore, W. and Ruiz, G. 2003. *Mid-ocean ballast water exchange: Approach and Methods for Verification*. Final Report to the US Coast Guard, Research and Development Center 124 pp + app.

United States Environmental Protection Agency, 1996. *Method 1669: Sampling ambient water for trace metals at EPA water-quality criteria levels*. U.S. Environmental Protection Authority online publication EPA# 821R96011. <http://yosemite.epa.gov/water/>

