

REPORT DOCUMENTATION PAGE

AFRL-SR-AR-TR-03-

Public reporting burden for this collection of information is estimated to average 1 hour per response, including the time for reviewing instructions, searching existing data sources, gathering the data, reviewing the collection of information, and completing and reviewing the collection of information. Send comments regarding this burden estimate or any other aspect of this collection of information, including suggestions for reducing the burden, to Washington Headquarters Services, Directorate for Information Operations and Reports, 1215 Jefferson Davis Highway, Suite 1204, Arlington, VA 22202-4302, and to the Office of Management and Budget, Paperwork Project Director, Paperwork Project (0704-0188), Washington, DC 20503.

0502

working
section

1. AGENCY USE ONLY (Leave blank)

2. REPORT DATE

3. REPORT TYPE AND DATES COVERED

01 APR 1999 - 30 SEP 2002 Final Report

4. TITLE AND SUBTITLE

THREE CORNER SAT CONSTELLATION

5. FUNDING NUMBERS

61102F

2305/BX

6. AUTHOR(S)

Dr Reed

7. PERFORMING ORGANIZATION NAME(S) AND ADDRESS(ES)

ARIZONA BOARD OF REGENTS
ON BEHALF OF ARIZONA STATE UNIVERSITY
BOX 871603
TEMPE AZ 85287-1603

8. PERFORMING ORGANIZATION
REPORT NUMBER

9. SPONSORING/MONITORING AGENCY NAME(S) AND ADDRESS(ES)

AFOSR/NE
4015 WILSON BLVD
SUITE 713
ARLINGTON VA 22203

10. SPONSORING/MONITORING
AGENCY REPORT NUMBER

F49620-99-1-0204

11. SUPPLEMENTARY NOTES

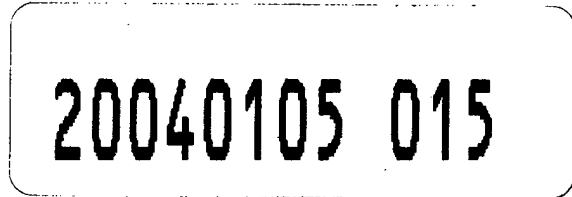

12a. DISTRIBUTION AVAILABILITY STATEMENT

APPROVED FOR PUBLIC RELEASE, DISTRIBUTION UNLIMITED

12b. DISTRIBUTION CODE

13. ABSTRACT (Maximum 200 words)

Three Corner Sat (3CS) is a part of the University Nanosatellite Program sponsored by AFOSR, DARPA and NASA GSFC. A joint collaboration among Arizona State University (ASU), the University of Colorado at Boulder (CU), and New Mexico State University (NMSU), the project demonstrates the feasibility of using nanosatellite technology for useful scientific endeavors while minimizing manufacturing and launch costs.

3CS includes a stack of three nearly identical satellites that will be deployed from the Multi-Satellite Deployment System (MSDS), designed by AFRL, after ejection from the Shuttle Hitchhiker Experiment Launch System (SHELS) in the NASA Space Shuttle. While the project has not been manifested on a particular shuttle launch, late 2003 is the anticipated launch date. Primary mission objectives include virtual formation flying, imaging, and end-to-end command and data handling. Secondary mission objectives include demonstrating MEMS micropropulsion technology, modular spacecraft bus design, and student education.

This final report is concerned with ASU's responsibilities and designated tasks required to successfully complete the team mission: Program Management of the project at the university level; Configuration Management and Safety; Structures, Mechanisms, Thermal and Radiation; Electrical Power System; Ground Support Equipment; MEMS Micropropulsion Experiment; Integration and Test; and SisterSat.

14. SUBJECT TERMS

15. NUMBER OF PAGES

16. PRICE CODE

17. SECURITY CLASSIFICATION
OF REPORT

UNCLASSIFIED

18. SECURITY CLASSIFICATION
OF THIS PAGE

UNCLASSIFIED

19. SECURITY CLASSIFICATION
OF ABSTRACT

UNCLASSIFIED

20. LIMITATION OF ABSTRACT

UL

Three Corner Sat Constellation (3ASat)
F49620-99-1-0204
Final Report to AFOSR/DARPA
December 2002

Abstract

Three Corner Sat (3CS) is a part of the University Nanosatellite Program sponsored by AFOSR, DARPA and NASA GSFC. A joint collaboration among Arizona State University (ASU), the University of Colorado at Boulder (CU), and New Mexico State University (NMSU), the project demonstrates the feasibility of using nanosatellite technology for useful scientific endeavors while minimizing manufacturing and launch costs.

3CS includes a stack of three nearly identical satellites that will be deployed from the Multi-Satellite Deployment System (MSDS), designed by AFRL, after ejection from the Shuttle Hitchhiker Experiment Launch System (SHELS) in the NASA Space Shuttle. While the project has not been manifested on a particular shuttle launch, late 2003 is the anticipated launch date. Primary mission objectives include virtual formation flying, imaging, and end-to-end command and data handling. Secondary mission objectives include demonstrating MEMS micropropulsion technology, modular spacecraft bus design, and student education.

This final report is concerned with ASU's responsibilities and designated tasks required to successfully complete the team mission: Program Management of the project at the university level; Configuration Management and Safety; Structures, Mechanisms, Thermal and Radiation; Electrical Power System; Ground Support Equipment; MEMS Micropropulsion Experiment; Integration and Test; and SisterSat.

Introduction

This final report is intended to give an overview of all areas of the Three Corner Sat (3CS) project while emphasizing areas specifically assigned to Arizona State University (ASU). A background of the project detailing its origins will first be given followed by an overview of management and schedule, system design (as related to ASU), configuration management and safety, and SisterSat. Finally, an assessment of student education and a listing of sponsors will be provided.

Background

3CS is sponsored under the University Nanosatellite Program run through the Air Force Office of Scientific Research (AFOSR), Defense Advanced Research Projects Agency (DARPA) and NASA Goddard Space Flight Center (GSFC). The University Nanosatellite Program is a Special Topic of the Broad Agency Announcement of the Air Force Research Lab (AFRL). Its initial concept stems from the TechSat21 Initiative in which formation flying satellites support five areas of basic research: micro-propulsion, sparse aperture radar, micro-electro-mechanical systems (MEMS), ionospheric effects, and collective behavior of intelligent systems.

Ten universities, split into teams, were given funding to research and show that constellations of nanosatellites could demonstrate the goals of the TechSat21 Initiative. Under the AFRL program name Nanosat-2, 3CS was created through a collaboration of three schools: ASU, the University of Colorado at Boulder (CU), and New Mexico State University (NMSU).

Overview and Mission Objectives

3CS is a stack of three satellites connected by a Lightband Intersatellite Separation System designed by Planetary Systems, Inc. The stack is mated to the Multi-Satellite Deployment System (MSDS) designed by AFRL. The MSDS, in turn, will be connected to the Shuttle Hitchhiker Experiment Launch System (SHELS) on a NASA Space Shuttle. Figure 1 shows a picture of 3CS in its original configuration (see the Post Delivery section for current configuration status). Once ejected from SHELS and MSDS, the stack will separate into three individual and nearly identical satellites. The 3CS mission operations begin at this point.

DISTRIBUTION STATEMENT A
Approved for Public Release -
Distribution Unlimited

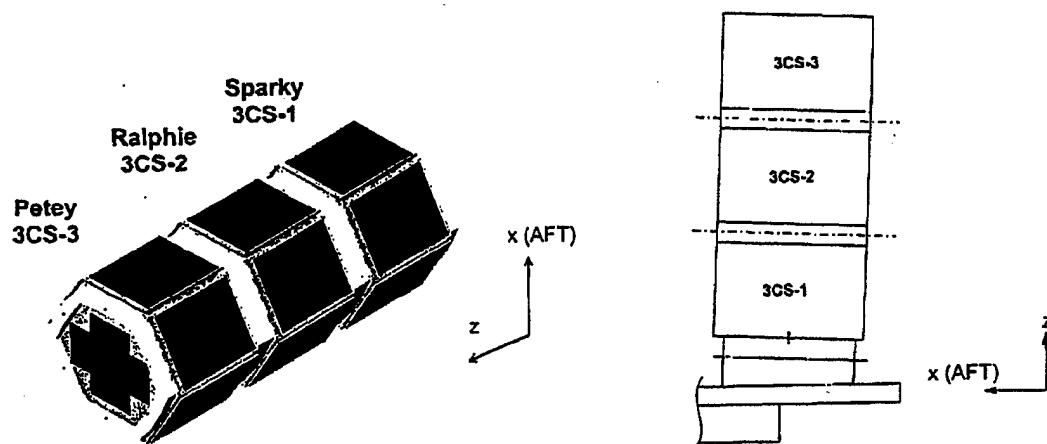

Figure 1: Stack Configuration

The 3CS mission objectives were derived from the TechSat21 goals. Primary mission objectives include virtual formation flying, imaging, and end-to-end command and data handling. Secondary mission objectives consist of demonstrating MEMS micropropulsion technology, modular spacecraft bus design, and student education. Since all secondary objectives are assigned to ASU, they will be discussed in more detail in the System Overview section.

Virtual Formation Flying

Virtual Formation Flying is demonstrated through a constellation of three nearly identical satellites, Petey, Ralphie and Sparky, named after NMSU, CU and ASU's school mascots respectively. The satellites are not required to be within an exact configuration with one another, hence the term virtual formation; however, communication from mission control to the satellites and their positions relative to one another are needed. Once these two requirements are met, the constellation can achieve the same results as an active formation control system. There are five main tasks planned to attain and analyze the virtual formation:

- Inter-satellite communications
- Coordinate mission science data acquisition
- Coordinate mission data results
- Determine the maximum range over which the virtual formation produces useable results
- Determine, to the extent possible, attitude or ranging effects on the ability of the system to produce useable results

The first two tasks will be accomplished by locking the satellites into a master-slave configuration. One satellite will communicate with the other two by transmitting messages. The master satellite will then relay this information to mission control. Master status will switch from satellite to satellite as each has a pass over one of the 3CS ground stations. The third task uses the files from the imaging experiments and sends them to the master satellite for transmission to the ground. It is expected that they will remain in communication with each other over a 100km distance. The final two tasks will quantitatively show maximum distances.

Each satellite uses modified TH-D7 Kenwood radios to communicate with each other and with the ground. These are commercially available ground-based radios. The completion of the experiment will also demonstrate that these radios are applicable to space vehicles as well. In addition to information received from the radios, Satellite Tool Kit (STK) is being used for orbit analysis of all three satellites. This software will help coordinate satellite passes over 3CS selected groundstations and determine orbit conditions such as eclipse for optimized satellite communications.

Imaging

Each spacecraft has four cameras used to take photographs of the Earth. The cameras' primary target is to photograph weather systems and other atmospheric phenomenon. In order to accomplish this, software has been developed to recognize probable pictures of the Earth versus pictures of space. It does this by analyzing the color pixel count. One hundred percent black or white would be considered "junk photos" whereas a mixture of black,

white, and other (blue, green, red, etc.) is a good picture. The images are then ranked on a scale from 0 - 100. The higher the rank, the better mixture of colors and thus the more likely it is an image of the Earth. Image download time is limited so top rankings are transmitted to mission control first. Mission operators can also view rankings before deciding to download.

Located on the top and bottom bulkheads and oriented to give the greatest field of view, each camera is a complimentary metal-oxide semiconductor (CMOS) JamCam2.0 Digital camera supplied by KB Gear Interactive. Other features of the cameras include full color, 640x480 pixel count, fully automatic exposure control, and power consumption of less than 50 mA at 9 volts. As commercial-off-the-shelf (COTS) hardware, their low cost and commercial availability are added advantages to the system. This will be one of the JamCam 2.0's first spaceflights and like the COMM radios, the imaging experiment will help demonstrate their applicability to space systems as well.

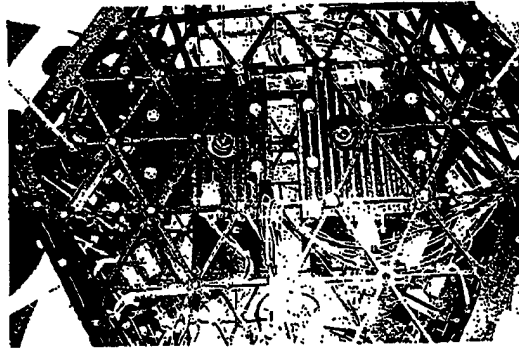

Figure 2: JamCam2.0 digital cameras attached to top bulkhead

End-to-end Command and Data Handling

The end-to-end data subsystem (EEDS) includes flight hardware, software and mission operators. Together, these three groups will plan and execute all mission schedules. The flight software controls all other subsystems and regularly performs data acquisition, storage and monitoring. EEDS provides both autonomous and distributed communications through the flight software and hardware. As a result, each satellite may act as an individual or in a master-slave configuration. The embedded software is written primarily in C++ using a VX Works operating system. A System Control Language (SCL), developed by Interface and Control Systems, Inc., helps organize a sequence of commands into scripts that minimize the number of commands an operator must enter in order to execute a task. In addition, there are two other programs being interfaced together into the flight software. CASPER, developed by the Jet Propulsion Laboratory (JPL), essentially acts as the brain of the satellite, capable of detecting and solving problems without manual intervention from the ground. ASPEN, another component, is a scheduling program that takes into account factors such as available power and compares it with necessary tasks to output a schedule that optimizes the functionality of the satellites.

Management and Schedule

Management and Team Divisions

The project is overseen on several different levels. The universities report to AFRL which in turn reports to NASA GSFC and the Space Test Program (STP) for clearance to launch on Shuttle using the SHIELS system. At the university level, three principal investigators, one from each school, provide guidance and support for the project; however, the program itself is entirely student staffed and run. A majority of the students are undergraduates and they are responsible for everything from initial concept and design to final integration and delivery to AFRL. They may participate as a volunteer, as a paid intern, or for class credit.

Table 1 is a hierarchical outline of program roles and points of contact. Subsystem leads are identified both by name and lead university responsible for the task.

Table 1: Team Organization

Organization / Role	Name	Affiliation
AFRL		
Program Manager	Jeff Ganley	AFRL/VSSV
System Engineer	Mark Kumashiro	Jackson & Tull Chartered Engineer
Payload Safety	Andrew Peffer	Jackson & Tull Chartered Engineer
Department of Defense Integration Manager	Major Don Hill	SMC/TELH
Integration and Test	Guy Robinson	Jackson & Tull Chartered Engineer
University Principal Investigators	Dr. Helen Reed	ASU
	Dr. Stephen Horan	NMSU
	Elaine Hansen	CU
University Program Manager	Lauren Egan	ASU
Subsystem Leads		
Structures Mechanisms Thermal Radiation	Priscilla Varela	ASU
Electrical Power Subsystem	Marc Chung	ASU
End-to-End Data Subsystem	Jennifer Michels	CU
Communications	Stephen Horan	NMSU
Imaging	Brian Egaas	CU
Micropropulsion experiment	Joyce Wong	ASU
Integration and Testing	Erik Henrickson	ASU
Configuration Management and Safety	Lauren Egan	ASU
Ground Support Equipment	Priscilla Varela	ASU

Rather than having each university design a single satellite, it was decided that each school would utilize its past flight history and be the primary lead in that particular area. NMSU is lead for all communications and ground station networks. CU works on the flight software and an imaging payload. ASU is in charge of program management, structures, electrical power systems, integration and testing, a micro-propulsion experiment, configuration management and safety, and ground support equipment.

Meetings and Communication

The University Nanosatellite Program provides a unique opportunity and challenge for students to learn how to communicate both with other subsystems and over long distances. Clear management and communication are necessary components for success in this environment. A weekly telecon is held with AFRL, NASA, STP, and the universities to discuss project development. Another weekly telecon is held for 3CS subsystem leads and PI's to discuss internal progress. Beyond these meetings, email is the primary form of communication for the three schools. During more detailed operations such as integration and testing and during design reviews, the schools also meet face-to-face for further discussion, but this is not on a frequent basis.

In addition to these team communications, ASU subsystem leads hold weekly meetings with their team members to discuss what needs to be done, train students, and teach concepts related to their subsystem.

Schedule

The project is currently in its fourth year of progress. Nanosat-2 has not been manifested on a particular Shuttle launch, but a late 2003 launch date is expected. One of the team's major successes came from its delivery of a complete stack to AFRL on February 19, 2002. The team has also successfully passed its NASA Phase 0/I Safety Review and does not anticipate any problems with the upcoming Phase II and III Safety Reviews. Table 2 shows the major project milestones.

Table 2: Project Milestones

Milestone	Date
Project Start	January 1999
System Requirements Review	August 1999
Technical Interchange Meeting	December 1999
Critical Design Review	April 2001
Phase 0/I Safety Review	June 2001
Build, I&T	July 2001 – Feb 2002
Delivery to AFRL	February 2002
Phase II Safety Review	August 2002
Phase III Safety Review	TBD
Launch	Late 2003

System Development and Overview

Development

3CS has been through some radical changes in its relatively short lifetime. A combination of schedule demands and launch vehicle changes caused major alterations to the program. The most significant alterations are discussed here to illustrate how 3CS has evolved and its greater implications for future satellite design at the university level.

3CS was originally intended for launch on a rocket, similar to the team's previous experience with ASUSat1 which launched on a Minotaur in January of 2000¹. The team took this into consideration during the design phase and planned accordingly. The estimated altitude was 750km, allowing for a gravity-gradient-boom-based attitude and

orbit determination and control (AODC) system. By late 2000, the universities were told that the launch vehicle would instead be a NASA Space Shuttle. Most likely an International Space Station mission, the new altitude would be approximately 350km. At this altitude the original AODC system was no longer appropriate. The AODC system was not the only component to change as a result of the announced launch on the Space Shuttle. Safety and configuration management became a greater concern. Launch on Shuttle meant tougher testing and material requirements. A more detailed explanation of these requirements is given in the CM and Safety section.

The team was also faced with significant time boundaries. The program was initially planned for a two-year time frame from concept to launch, an aggressive schedule even by industry standards. As of 2001, the team decided that it must down-scale some of its original mission objectives in order to ensure delivery. Stereoscopic imaging and a full micropropulsion unit were the two subsystems that had the most significant schedule impact. Design alterations included changing the gimbaled cameras to four stationary cameras. With the pointing accuracy requirement eliminated, the AODC system could be taken off as well. Each satellite would now have passive control. The micropropulsion unit also originally proposed to be flown was a newly developed free molecule micro-resistojet (FMMR)². This experiment was reduced to testing the MEMS heater chip on board. These MEMS chips are the most crucial aspect of the system and it will be the first time this version of the chip is tested in a space environment. As a result, valuable science is still gained from demonstration of the chip alone. Changing some of the original plans allowed for greater flexibility with the schedule.

The team discussed several different ways to accommodate the new launch vehicle and keep up with the schedule, but in the end, it was decided to scale back some of the design. However, the reductions brought three major gains to the team. First and foremost, we successfully delivered our satellite stack. Looking back, the team realizes that none of our mission objectives would have been accomplished without rethinking our approach. It also helped with our Safety Reviews and mass properties. After the reductions, no mechanisms, pressurized vessels or toxic materials were on the spacecraft helping to prevent any concerns or problems at the Phase 0/1 Safety Review. The team was also given a limit of 100lbs. Having the extra equipment on board would have greatly increased our mass.

This brief look at the development of the satellite stack is intended to show that the process is just as valuable as the final design and integration understanding. Experiencing and handling change is a crucial aspect to the student learning process, enabling the student to adapt and decide mission priorities as needed.

System Overview

The following system overview is for subsystems developed by ASU. It includes EPS, SMTR, the micropropulsion experiment, and I&T.

Electrical Power System (EPS)

All boards for EPS were designed and populated in-house by students at ASU. They include electronics for power regulation, CPU watchdog, power switching, voltage, temperature and current measurement. Ten Sanyo Cadnica KR-2300 NiCd cells provide power for each satellite. The cell rating is 1.2 volts and 2.3 A-h and the orbit average power is 12 watts. Each cell is vented and electrolyte-starved to prevent leakage. A copper ring for heat dissipation, and Teflon and PigMat for leak protection surround the cells. The battery box is also vented per NASA Safety Requirements. Battery recharging comes from dual junction Gallium Arsenide (GaAs) solar arrays bonded to non-load-bearing aluminum honeycomb core composite panels attached to the outside of the spacecraft. Each solar cell generates approximately 2.1V. Two strings of nine cells are attached to each composite side panel and one string of nine is bonded to each bulkhead composite panel.

Power from the batteries or solar cells can go to each system through a 12V or a 5V line depending on which subsystem needs the power.

Also due to NASA Safety Requirements, EPS has a total of seven magnetic latching relays to electrically inhibit the satellites until ejection from the MSDS. These relays also prevent the battery from being charged by the solar cells while inhibited. Side connectors on each satellite allow for inhibit verification. Prior to deployment from the MSDS, the inhibits will be removed and mission operations can begin.

Structures, Mechanisms, Thermal and Radiation (SMTR)

The main bus is a hexagonal iso-grid structure machined out of Aluminum 6061. As the primary load bearing structure, the teeth surrounding each panel interlock for a more secure structure. The main frame is connected with #10 SHCS (Socket Head Cap Screws) and supported by side brackets that use #8 SHCS. Each satellite frame measures 16.5 inches face to face and 11.5 inches high. Figure 3 shows a picture of the main bus.

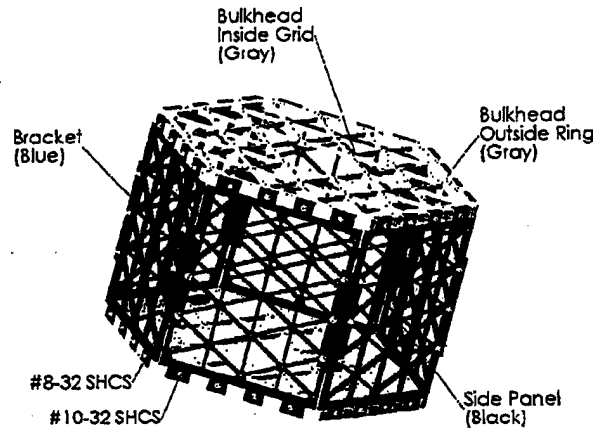

Figure 3: Iso-grid structure

All fasteners are in accordance with GSFC Document 541-PG-8072.1.2, GSFC Fastener Integrity Requirements. Locking helicoil and Uralane 5753 are used to aid in back-out protection for all screws (per MIL-I-8846 and MIL-N-25027). The entire structure, including EMI boxes inside, is anodized black. Particular areas were masked during the anodizing process to ensure electrical continuity per NASA Safety Regulations. EMI boxes are also made of Aluminum 6061 and are designed by students. Figure 4 shows an exploded view of the satellite and its component boxes.

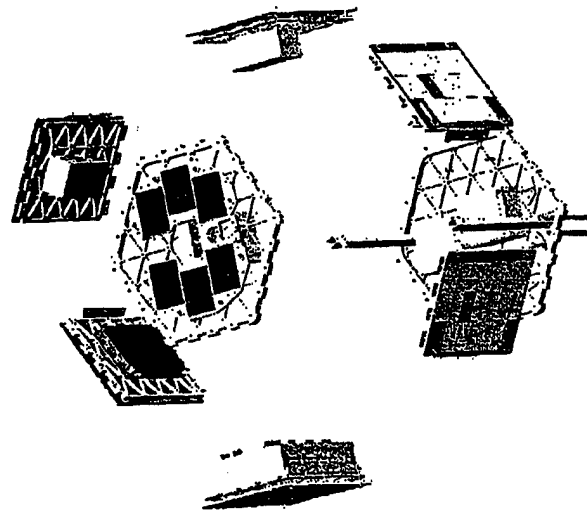

Figure 4: Exploded satellite view

This bus design fulfills the mission objective of a modular, generic design. The iso-grid panels can be taken off one at a time allowing for easy access to specific components. A hole also exists at each ribbing intersection on the iso-

grid. Components can be moved around to accommodate CG and mass requirements. The main bus design can also be used for future missions; the current payloads are swapped out for new ones. Having the ribbed pattern allows for reduction of unnecessary mass while still maintaining the structural integrity of a solid panel.

MEMS Micropropulsion Experiment

Testing of the MEMS chip is a collaborative effort with AFRL Edwards Air Force Base. It is part of a larger unit called the Free Molecule Micro-Resistojet (FMMR). FMMR is an innovative design that uses water, a readily available and non-toxic material, as its propellant to provide micro-newtons of thrust². This experiment will validate the MEMS heater chip for use in the FMMR design. The heater chip is the most vital component of the propulsion system's success. There are two FMMR units on 3CS, one on Petey and one on Ralphie. Each has two FMMR chips mounted on a machined Teflon plenum. The plenum is mounted on the outside of a bottom bulkhead with 2 bolts. The chip measures approximately 0.51 x 1.65 inches (13 x 42 mm) and is primarily made of a silicon nitride coated silicon wafer. One primary difference between the 2 chips is that one will have its backside (exposed to space) completely coated with gold, and the other will expose the silicon nitride layer. Different chip surfaces are being used to characterize them under differing surface temperatures. Even though the chips will be given the same amount of power, the difference in emissivity will cause the surface temperatures to be different. Each chip weighs about 0.02 oz (0.5 gram). The chips will be tested by measuring temperature and current. These data sets will allow the MEMS chips to be characterized for future use in a FMMR unit. Figure 5 shows the chips in the housing that will attach them to the satellite bus. The protective cover shown will be removed before flight.

Integration and Test (I&T)

Almost all I&T took place at ASU. Individual components such as the EEDS box and cameras, assembled at another university, were sent to ASU for final integration. When possible, test equipment at ASU was used. A small vacuum chamber was assembled for all epoxy mixing and a thermal chamber was created for battery cell acceptance testing. Other test requirements such

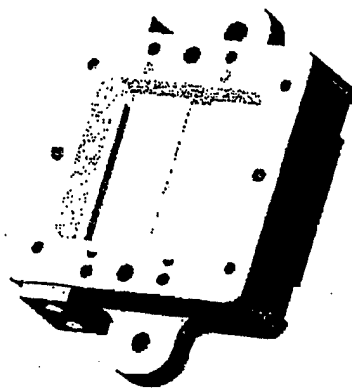

Figure 5: MEMS chip in housing

as random vibration and sine burst were outsourced to local testing facilities in Arizona. A rigorous hardware tracking and integration documentation system was followed ensuring proper integration (see CM and Safety section).

Configuration Management (CM) & Safety

CM and Safety are an integral part of one another and in order to successfully pass our NASA Safety Reviews a detailed CM plan was created. Using guidance from AFRL on required measures, the following list shows the major requirements for CM:

- Two person verification for all design, assembly, integration and testing
- Certificates of Compliance for all components and materials purchased
- Hardware tracking logs
- Restricted access to electronic files related to design
- Lightband operator certification

- Assembly and Test Logs for all components

The team recognized that successful CM meant increased confidence in the safety of our system. In order to pass each safety review, the list below details the requirements the stack had to meet:

- Sine Burst: Test Load = 23.8 G >22 Hz in each axis
- Random Vibration: min. 1st fundamental frequency of >50 Hz (35Hz absolute min.) for 3CS and MSDS together
- Total Nanosat-2 mass < 400 lbm
- Pressurization/depressurization analysis
- Materials with high resistance to stress corrosion cracking (SCC)
- Maximum collectable volatile condensable material content of 0.1% or less
- Total mass loss of 1.0% or less

Post Delivery Update

After combined Nanosat-2 (3CS and MSDS together) testing completed by AFRL, it was found that the system did not meet the minimum first fundamental frequency of 35Hz for random vibration testing. As a result, the stack was partially separated so that Sparky now stands alone on MSDS and Petey and Ralphie remain as a stack. Subsequent testing has shown that Nanosat-2 is now in compliance with all NASA Safety Requirements for testing.

SisterSat

Satellite delivery was not the end of 3CS. The team is now shifting its efforts to SisterSat, an identical working replica of 3CS. Both ASU and CU will have units. Shortly before delivery, another full team meeting was held in Colorado to discuss Mission Operations and brainstorm for Failure Modes and Effects Analysis (FMEAs). CU will be using its units to continue software testing and train mission operators for post launch operations. ASU will be using its units as a training tool for new members coming onto the team and in preparation for the upcoming safety reviews. Information transfer and training tools like SisterSat are essential in the university environment where the man-power turn over rate is high due to a student's limited lifetime. Having working models built to the same standards as the actual 3CS units will also help with any problems encountered on orbit.

Student Education and Lessons Learned

The entire 3CS experience has been a learning lesson for the team. Most obvious are the particular skills students have learned such as CAD programs, software design, and integration practices, but more importantly, the team has gained qualitative experience in the field of engineering that serves to compliment and heighten the academic pursuits at the university level. Some of these lessons learned are discussed below.

Students have had the opportunity to interact with industry and government agencies that have shown them how engineering practices are implemented in a non-university setting. This is beneficial to both the students and industry. Students receive hands-on experience and industry members know they have trained graduates from which to hire. For government agencies and industry, basic research is provided at a low cost, relatively speaking, with high returns.

The team has also found that, usually, simpler is better. When a student first designs a part, complicated mechanisms and patterns are often incorporated. When that student has to go machine the part, she begins to understand that some designs are either impossible to machine or too expensive for consideration. This is knowledge that only comes through experience and cannot be taught in a classroom.

Simplicity can also mean reduction and reevaluation of mission objectives. The team understands that reduction is not about losing, but rather, about winning. Successful delivery would not have occurred without the decision to cut back on some subsystems. More importantly it is about responsible engineering. Satellite delivery is not as valuable unless the job has been done well. Improper craftsmanship is just as serious as failing to deliver.

Another lesson learned comes from documentation. The university environment is constantly changing, especially with the limited lifetime of a student. We have had six university program managers and over 200 students working on 3CS since it first started in 1999. Properly documenting our designs and integration process stabilizes the team and ensures thorough information transfer.

Finally, we have learned that communication is essential to team success. Working together in different states allows for misunderstandings and misrepresentations. Effective communication provides the path in which the team can move forward and make significant progress.

Sponsors

Sponsors are a crucial aspect of mission success. The following groups have generously provided the team with either their time, financial support, expertise, discounts, or free materials.

AFOSR
DARPA
NASA Space Grant
AFRL Kirtland
Space Test Program
NASA Goddard
AFRL Edwards / USC
NASA JPL
Analytical Graphics (STK)
Ball Aerospace
Boeing
Dynamic Labs
Embedded Planet
Enerflex Solutions
FreeFlyer
Hexcel
Honeywell
International Foundation for Telemetry
KB Gear
Lockheed Martin
McFarland Machine & Engineering
Microchip
Orbital Sciences
SpaceWorks
Spectrum Astro
SunCat Solar
Universal Wire
Welch Military Packaging

Conclusion

Working on the 3CS project has been an invaluable experience for all of the students. It has given them the opportunity to learn some new technical skills and begin to understand how smaller subsystems integrate into a much larger picture. More importantly though, it is an opportunity for students to extend their traditional academic education and learn that satellite design requires teamwork, communication and flexibility. It has also been the start of many professional and personal relationships that will continue well beyond the short time at their respective universities.

3CS is a part of the University Nanosatellite Program run by AFRL and sponsored by AFOSR/DARPA/NASA GSFC. At the university level, it is completely student run and managed. A collaboration of ASU, CU, and NMSU, its mission objectives include virtual formation flying, imaging, end-to-end command and data handling, demonstrating MEMS micropropulsion technology, modular spacecraft bus design, and student education. A brief system overview was given explaining the development process and more detailed information was given for subsystems assigned to ASU followed by the present and future status of the project.

Honors (ASU)

Helen Reed named Fellow, American Physical Society, September 2003
1st Place in Team Division, Western Regional Student Competition, AIAA Foundation Student Competition, Seattle, Washington, April 10-13, 2003
Helen Reed received Excellence in Service Award, Faculty Achievement Award, ASU Alumni, Founders' Day, March 12, 2003.
Three Corner Sat team invited to display satellite hardware as part of AFOSR 50th Anniversary, Washington, D.C., April 25, 2002.
Three Corner Sat student satellite successfully delivered to Air Force Research Lab in Albuquerque, February 19, 2002. Launch on NASA Space Shuttle, date TBD.
Three Corner Sat team invited to display satellite hardware as part of DoD STP exhibit at NASA Johnson Space Center Public Open House, August 25, 2001.
4th Place in Student Competition at 14th AIAA/USU Small Satellite Conference, 2000
Helen Reed received Outstanding Mentor Award, Graduate Women's Association, April 2000
Hall of Fame Award for "Pride & Tradition" to ASUSat Team, Student Organization Resource Center (SORC) and ASU Community Service Program, April 19, 2000
SOAR (Student Organization Awards and Recognition) Award to ASUSat Team, College of Engineering Alumni Association, February 24, 2000
Successfully launched and commanded 6-kg very capable nanosatellite ASUSat1, January 26 at 19:03 PST on 1st Air Force OSP from Vandenberg AFB, 2000
ASUSat1 designated AO-37 (ASUSat OSCAR-37) by AMSAT-NA, 2000
Team invited to Washington D.C. for all-expenses-paid 3-day "ASU Space Student Satellite Workshop" by Rear Admiral Paul Gaffney, Chief of Naval Research, May 1999

References

1. "ASUSat1: Low-Cost, Student-Designed Nanosatellite," A. Friedman, B. Underhill, S. Ferring, C. Lenz, J. Rademacher, H. Reed, *AIAA Journal of Spacecraft and Rockets*, Volume 39, Number 5, Pages 740-748, September-October 2002.
2. "The University Microsatellite as a Micropropulsion Testbed," J. Wong, H.L. Reed, A. Ketsdever, *Micropropulsion for Small Spacecraft, AIAA Progress in Astronautics and Aeronautics Series*, Volume 187, Pages 25-44, 2000. (Paper originally peer reviewed and accepted to *AIAA Journal of Propulsion and Power*. Editors decided to create *AIAA Progress Series* volume from selected accepted papers.)