

AD \_\_\_\_\_

Award Number: DAMD17-00-1-0279

TITLE: Kinase Independent Functions of Cyclin D1 Which  
Contribute to its Oncogenic Potential In Vivo

PRINCIPAL INVESTIGATOR: Mark W. Landis  
Philip W. Hinds, Ph.D.

CONTRACTING ORGANIZATION: Harvard Medical School  
Boston, MA 02115-6027

REPORT DATE: July 2003

TYPE OF REPORT: Annual Summary

PREPARED FOR: U.S. Army Medical Research and Materiel Command  
Fort Detrick, Maryland 21702-5012

DISTRIBUTION STATEMENT: Approved for Public Release;  
Distribution Unlimited

The views, opinions and/or findings contained in this report are those of the author(s) and should not be construed as an official Department of the Army position, policy or decision unless so designated by other documentation.

20040112 145

# REPORT DOCUMENTATION PAGE

Form Approved  
OMB No. 074-0188

Public reporting burden for this collection of information is estimated to average 1 hour per response, including the time for reviewing instructions, searching existing data sources, gathering and maintaining the data needed, and completing and reviewing this collection of information. Send comments regarding this burden estimate or any other aspect of this collection of information, including suggestions for reducing this burden to Washington Headquarters Services, Directorate for Information Operations and Reports, 1215 Jefferson Davis Highway, Suite 1204, Arlington, VA 22202-4302, and to the Office of Management and Budget, Paperwork Reduction Project (0704-0188), Washington, DC 20503

<b>1. AGENCY USE ONLY</b> (Leave blank)		<b>2. REPORT DATE</b> July 2003	<b>3. REPORT TYPE AND DATES COVERED</b> Annual Summary (1 Jul 2000 - 30 Jun 2003)	
<b>4. TITLE AND SUBTITLE</b> Kinase Independent Functions of Cyclin D1 Which Contribute to its Oncogenic Potential In Vivo			<b>5. FUNDING NUMBERS</b> DAMD17-00-1-0279	
<b>6. AUTHOR(S)</b> Mark W. Landis Philip W. Hinds, Ph.D.				
<b>7. PERFORMING ORGANIZATION NAME(S) AND ADDRESS(ES)</b> Harvard Medical School Boston, MA 02115  E-Mail: mlnadis@fas.harvard.edu			<b>8. PERFORMING ORGANIZATION REPORT NUMBER</b>	
<b>9. SPONSORING / MONITORING AGENCY NAME(S) AND ADDRESS(ES)</b> U.S. Army Medical Research and Materiel Command Fort Detrick, Maryland 21702-5012			<b>10. SPONSORING / MONITORING AGENCY REPORT NUMBER</b>	
<b>11. SUPPLEMENTARY NOTES</b>				
<b>12a. DISTRIBUTION / AVAILABILITY STATEMENT</b> Approved for Public Release; Distribution Unlimited				<b>12b. DISTRIBUTION CODE</b>
<b>13. ABSTRACT (Maximum 200 Words)</b>  Cyclin D1, an important cell cycle regulator, is a potent oncogene in several tumor types, including breast cancer. The most well understood function of cyclin D1 is to bind and activate cdks 4 and 6. One target of these kinases is pRb. Upon phosphorylation, pRb is inactivated, and cells pass from G1 into S phase. We and others have demonstrated that cyclin D1 has other functions, many of which are independent of kinase activity <i>in vitro</i> . <i>In vivo</i> demonstration of kinase independent functions of cyclin D1 may help elucidate the underlying mechanisms of cyclin D1 oncogenicity. To determine whether cyclin D1 has important kinase-independent functions <i>in vivo</i> , we are generating a cyclin D1 K112E knock-in mouse. This single base change results in a cyclin that can bind to, but not activate the kinase partner. As the locus will be left almost undisturbed, we expect that the mutant allele will be expressed in a normal manner. The phenotype of the mouse will be analyzed to determine whether any of the phenotypes of the cyclin D1 <i>-/-</i> mouse are rescued. This analysis will allow dissection of how the kinase-independent functions of cyclin D1 contribute to development, proliferation and oncogenesis <i>in vivo</i> .				
<b>14. SUBJECT TERMS</b> Cell Cycle, cyclin, development, animal model, proliferation control oncogene, tumor suppressor, knock-in mouse			<b>15. NUMBER OF PAGES</b> 19	
			<b>16. PRICE CODE</b>	
<b>17. SECURITY CLASSIFICATION OF REPORT</b> Unclassified	<b>18. SECURITY CLASSIFICATION OF THIS PAGE</b> Unclassified	<b>19. SECURITY CLASSIFICATION OF ABSTRACT</b> Unclassified	<b>20. LIMITATION OF ABSTRACT</b> Unlimited	

## Table of Contents

Cover.....	1
SF 298.....	2
Table of Contents.....	3
Introduction.....	4
Body.....	4
Key Research Accomplishments.....	6
Reportable Outcomes.....	6
Conclusions.....	6
References.....	7
Appendices.....	8

## Introduction

Cyclin D1, an important cell cycle regulator, is a potent oncogene in several tumor types, including breast cancer. The most well understood function of cyclin D1 is to bind and activate cyclin dependent kinases (cdks) 4 and 6. One target of these kinases is pRb. Upon phosphorylation, pRb is inactivated, and cells pass from G1 into S phase. We and others have demonstrated that cyclin D1 has other functions, many of which are independent of kinase activity *in vitro*. *In vivo* demonstration of kinase independent functions of cyclin D1 may help elucidate the underlying mechanisms of cyclin D1 oncogenicity.

To determine whether cyclin D1 has important kinase-independent functions *in vivo*, we are generating a cyclin D1 K112E knock-in mouse. This single base change results in a cyclin that can bind to, but not activate the kinase partner. As the locus will be left almost undisturbed, we expect that the mutant allele will be expressed in a normal manner. The phenotype of the mouse will be analyzed to determine whether any of the phenotypes of the cyclin D1 *-/-* mouse are rescued. This analysis will allow dissection of how the kinase-independent functions of cyclin D1 contribute to development, proliferation and oncogenesis *in vivo*.

## Body

To determine which functions of cyclin D1 are important *in vivo*, we have undertaken the generation of a knock-in mouse. Mouse embryonic stem cells were targeted for homologous recombination with the targeting construct shown (figure 1). Following selection, ES clones were screened for homologous recombination. Several clones screened positive in Southern Blot, PCR, and karyotyping. Three clones have now been injected into blastocysts. Of these, the first has been transmitted into the germ-line, the other two are currently in progress.

From the first injection, three male and one female chimeras were obtained. Two of the males produced a total of seven agouti offspring, indicating germ line transmission of the ES cells. Of the seven offspring, three males screened positive for the KE allele by PCR (figure 2). These males were then crossed to wild-type animals to generate female animals carrying the allele. Due to technical concerns about treating ES cells with CRE, we opted to remove the flox-neo drug cassette by mating heterozygote animals to transgenic animals carrying the CRE recombinase under control of the nestin promoter (nestin-cre). Progeny of these crosses were screened by PCR for the presence of the KE allele and absence of the flox-neo cassette. These progeny were found and crossed together to generate homozygous KE/KE animals (figure 3). To ensure that these animals carried the desired allele, the PCR product was subcloned and several clones were sequenced. As shown, the wild type animal carries a lysine residue at position 112, whereas the knock-in animals have a glutamate residue at this position.

D1 *-/-* animals are substantially smaller than their wild-type littermates. To determine whether this is also the case for KE/KE animals, we weighed litters of progeny generated from crosses of KE/+ animals. The KE/KE animals are substantially smaller than the wild-type littermates (figure 4A); however, they are probably not quite as small as the D1 *-/-* animals. We are currently back-crossing the KE allele into the same strain background as the D1 *-/-* so that we can make a direct comparison. A second phenotype of the D1 *-/-* animal is a 'claspings' reflex: when the mouse is lifted by the tail, it brings its rear legs together rather than splaying them as the wild-type mouse does. As shown, the KE/KE mouse also exhibits this claspings phenotype when lifted (figure 4B).

In addition to the D1 *-/-* animal's size deficiency, two tissues in this mouse are profoundly affected by the absence of cyclin D1. The retinas of the knockout are severely hypoplastic, developing only a few layers of cells. In addition, the mammary glands of the knockout are deficient in

proliferation in response to the hormonal signals of pregnancy. Eyes from KE animals and their wild-type littermates were dissected and fixed in Bouin's. Eyes were embedded, sliced, and stained with H&E. The KE sections were examined and exhibited only a mild defect, with the cell layers being slightly thinner than the wild-type layers (figure 5). KE females were mated and at day 1 post-partum were sacrificed. Mammary glands were dissected and whole-mount staining performed. Analysis of the mammary glands revealed relatively normal development of the mammary epithelium compared to wild-type (figure 5).

To quantitate the defect in the retinas of the KE animals, electroretinograms (ERG) were performed on three KE mice and three of their wild-type littermates. Following the ERG, the eyes of these mice were dissected and fixed in Bouin's. Sections were stained with H&E and exhibited a partial defect in development, having fewer layers of neurons than wild-type littermates (figure 6). The results of the ERGs showed that the KE eyes functioned at approximately 65% of wild-type levels (figure 7).

To examine the biochemical properties of the KE protein, lysates were made from E. 14.5 embryos. To compare levels of various cell cycle regulators, Western Blot analysis was performed. Levels of cyclin D1, D2, D3, p27, CDK4, CDK6 and pRb were equivalent in the KE animal and the wild-type littermate (figure 8). Mouse cyclin D1 runs as a doublet, and interestingly the relative abundance of the fast vs. slow migrating form is changed in the KE animal, with the faster migrating form being more abundant. We intend to attempt to determine whether these forms are differentially phosphorylated.

To determine the ability of the KE protein to bind to its kinase partner, IPs were performed. Either cyclin D1 or CDK4 was immunoprecipitated from embryo lysates and the material subjected to PAGE. The resulting Western Blots were probed for cyclin D1, CDK4 or p27 (figure 9). Interestingly, not as much KE came down in the IP as did wild-type D1. This presents a technical issue, as measuring the activity of cyclin D1 and KE depends on the ability to IP equivalent amounts of protein from the lysates. It will be necessary to test a panel of anti-D1 antibodies to try to obtain one that will both IP equivalent amounts of protein and support kinase activity. In the CDK4 IP, it appears that a slightly lower amount of KE binds to CDK4 than wild-type D1. However, the total amount of p27 bound to CDK4 is equivalent. This is important because p27 is capable of redistributing away from CDK4 complexes to cyclin E/CDK2 complexes and inhibiting them. To test whether p27 pools were mobilizing and changing the activity of CDK2, a CDK2 IP-kinase assay was performed (figure 10). CDK2 complexes were immunoprecipitated from lysates and used to phosphorylate histone H1 in an *in vitro* kinase assay. Activity was variable in this experiment, and shows no consistent decrease in KE animals.

In addition, we have performed similar biochemical analysis in the retinas of KE animals. Mice were sacrificed on the day of birth and the neural retinas were microdissected and subjected to Western Blot analysis. Interestingly, a number of changes in cell cycle regulators was observed in these tissues. Cyclin A, CDK4, and p27 levels were reduced in knock out and KE animals relative to wild-type littermates. In addition, Cyclin E levels were higher in the KE retinas (figure 11). These observations may suggest that there is a subtle defect in cell cycle control in these retinas. pRb phosphorylation at serine 780, a putative CDK4 target site, was analyzed with a phospho-specific antibody and was shown to be decreased in both knockout and KE retinas. In addition, a pan-Rb antibody revealed significant differences in pRb phosphorylation in the KE retinas (figure 12). These results suggest that there is a defect in the ability of CDKs to phosphorylate their targets in the KE animal. This may be due entirely to deficient activation of CDK4 by KE, or a combination of this and inhibition of Cyclin E. Experiments are ongoing to determine the exact mechanism.

To further investigate the size differences in the knockout and KE animals, we analyzed the levels of serum IGF-1. The pituitary glands of the CDK4 knockout mouse are defective in the number of certain hormone producing cells (1). Therefore, we examined the level of IGF-1, a proxy for the level of growth hormone produced by the pituitary. Interestingly, we found that the level of IGF-1 was lowest in knockout animals, and was low in KE animals relative to wild-type littermates (figure 13). Indeed, these levels of IGF-1 correlate with the relative sizes of these animals. Future investigation of the pituitary gland may reveal an interesting and currently unappreciated role of cyclin D1 in the size control pathway.

To test the KE mutant in a more demanding system, we have crossed the KE mouse and the Cyclin D2 knockout. It has been shown that the cerebella of the Cyclin D1/Cyclin D2 double knockout is profoundly defective, with fewer folia and abnormal layering of the Purkinje cell layer (2). We examined the cerebella from KE; D2<sup>-/-</sup> mice and found a similar defect in the cerebella (figure 11). Cyclins D1 and D2 are expressed in the cerebellum, but no D3 is found. We speculate that the development of this tissue is exquisitely sensitive to the level of cyclin D-associated kinase activity and therefore development collapses in the absence of D2 and presence of the kinase dead KE. Confirmation of this hypothesis awaits the collection of cerebella of the proper genotypes and analysis of biochemistry.

As noted in the previous annual report, the absence of cyclin D1 can completely protect mice against some induced breast cancers (3). We are well on the way to generating the four groups of mice (Wt/MMTV-neu, Wt, KE/MMTV-neu, and KE) that will allow the determination of whether Cyclin D1-associated kinase activity is necessary for the induction of certain types of breast cancer. This study should shed light on the value of cyclin D1 dependent kinase activity as a therapeutic target in breast cancer.

### **Key Research Accomplishments**

- Generation of mice homozygous for the cyclin D1 K112E allele
- Characterization of the phenotype of this animal including: size, retinal development, mammary gland development
- Biochemical characterization of this animal including: KE protein expression, KE complex formation, and CDK2 activity
- Biochemical characterization of the retina of the KE animal including: KE protein expression, analysis of cell cycle regulators, and analysis of pRb phosphorylation
- Investigation of IGF-1 levels in knockout and KE mice
- Generation and analysis of cerebella from KE/D2<sup>-/-</sup> mice
- Generation of the four groups of mice necessary to study the role of Cyclin D1 in breast tumorigenesis

### **Reportable Outcomes**

- Generation of homozygous animals carrying two copies of the K112E allele
- Generation of KE/D2<sup>-/-</sup> mice
- Generation of KE/MMTV-neu mice for use in the tumor study
- Abstract presented at the DOD breast cancer conference

### **Conclusions**

Homozygous mice carrying two alleles of cyclin D1 K112E have been generated. We have been characterizing the phenotype of these animals and comparing them to the wild-type and cyclin D1

knockout animals. The KE animals are smaller than the wild-type animals and clasp their rear legs when lifted. However, the defects in the retina and mammary gland of the KE animal are quite mild compared to the severity of these deficiencies in the knockout.

To analyze the mechanisms at work in these animals we have begun to investigate the biochemistry and molecular biology in these tissues. Cyclin D1 KE is expressed in the knock-in mouse at an approximately equivalent level as in the wild-type mouse. It appears that KE may not bind to CDK4 as robustly as wild-type cyclin D1; however, this does not result in p27 shifting to cyclin E complexes. Indeed, CDK2 activity is similar in KE and wild-type tissues.

In addition, we are investigating the biochemistry of the developing retina in the KE animal. Interesting differences between wild-type, KE, and knockout retinas have been observed. It appears that kinase activity has something to do with development in this tissue, as the eyes were not completely functional. However, other functions of cyclin D1 may also play a role here as they eyes were not profoundly deficient. To examine another tissue which is affected by loss of cyclin D1, we have begun to characterize the cerebellum of the KE/D2<sup>-/-</sup> animal. This organ is profoundly defective, being very small, having fewer folia, and having abnormal purkinje cells. Biochemical analysis of this tissue should be informative.

In addition, we have begun to study the ability of the KE mutant to support breast tumorigenesis. We have chosen to use MMTV-neu to try to induce tumors in various cyclin D1 and KE backgrounds. This study should reveal whether cyclin D1-associated kinase activity is necessary for induction of breast cancer mediated by c-neu. In addition, this study should shed light on the value of cyclin D1 dependent kinase activity as a therapeutic target in breast cancer.

## References

1. Moons DS, Jirawatnotai S, Parlow AF, Gibori G, Kineman R, Kiyokawa H. Pituitary hypoplasia and lactotroph dysfunction in mice deficient for cyclin dependent kinase-4. *Endocrinology* 143(8)
2. Ciemerych MA, Kenney AM, Sicinska E, Kalaszczyńska I, Bronson RT, Rowitch DH, Gardner H, Sicinski P. (2002). Development of mice expressing a single D-type cyclin. *Genes and Development* 16: 3277-3289.
3. Yu Q, Geng Y, Sicinski P. (2001). Specific protection against breast cancers by cyclin D1 ablation. *Nature*. 411(6841):1017-21.

**APPENDIX COVER SHEET**

**FIGURES 1-14**

# Mouse Cyclin D1 K112E Knock-In

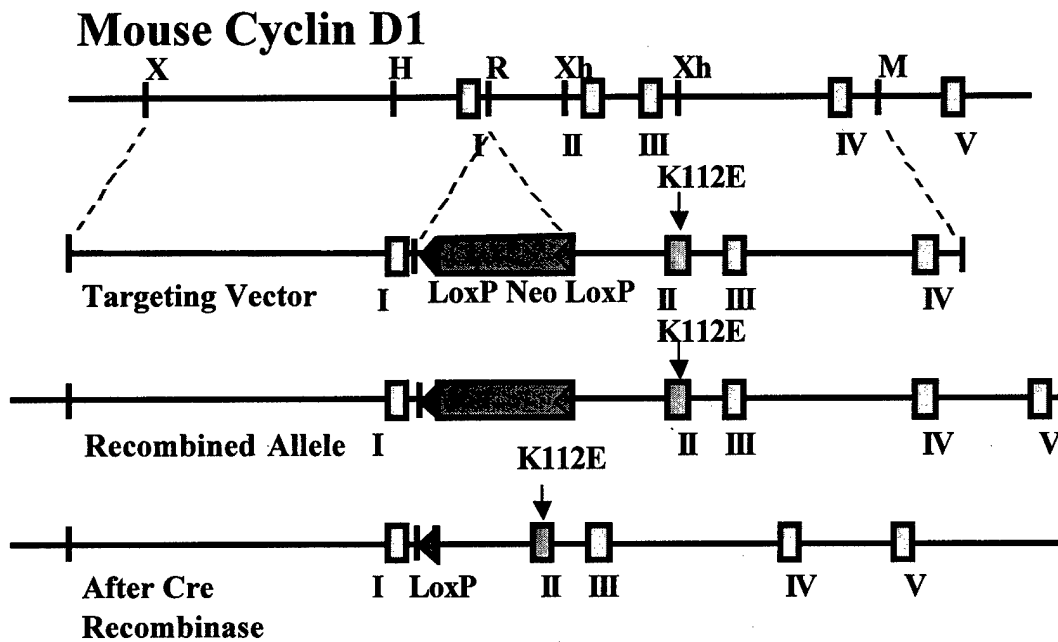

Figure 1. The targeting cassette used to generate ES cells contains a floxed-neo gene used for selection and a single base change that will generate the K112E mutation. After recombination and treatment with the Cre recombinase, the locus will be left virtually undisturbed

**PCR of 3 F1 Progeny of KE Chimeric Males  
Demonstrates Germ-Line Transmission of the Allele**

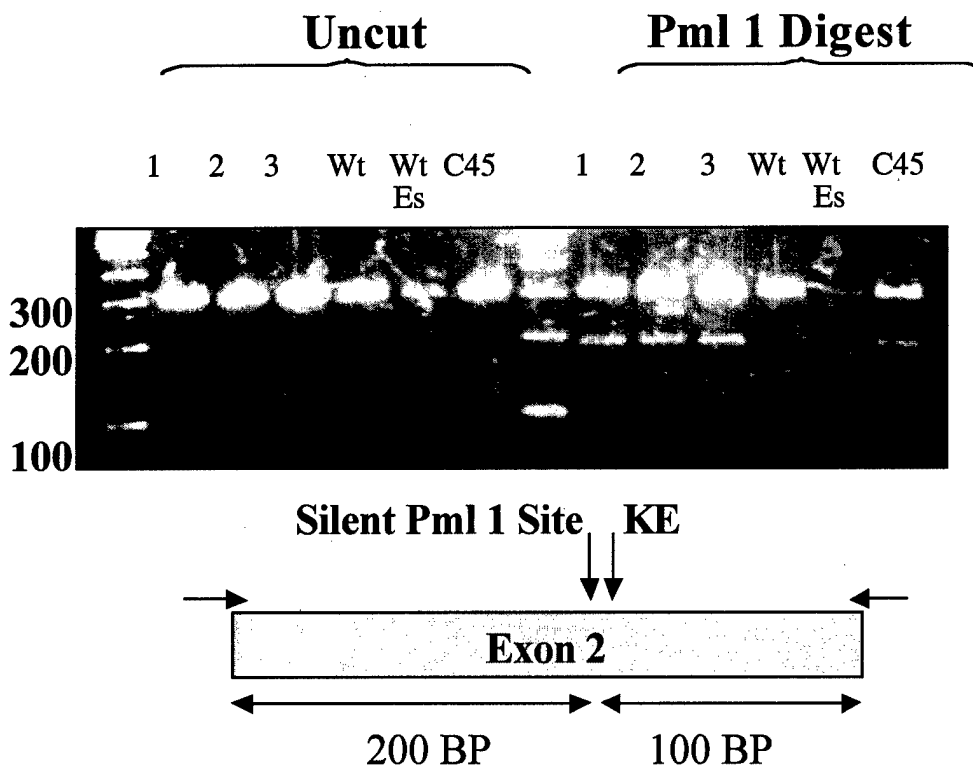

Figure 2. DNA from agouti progeny of the chimeric animals was subjected to PCR to determine whether the animals were transgenic for the desired allele. A silent Pml1 site was built in to the targeting cassette. PCR across the region yields a 300 bp fragment that when digested gives a 200 and 100 bp fragment indicative of the knock-in allele. Agouti progeny 1-3 and C45 (the original ES clone used to generate the chimeras) all demonstrate the knock-in allele, whereas a wild-type (Wt) mouse and wild-type ES cells do not show these bands when digested with Pml1.



## The KE Mouse Exhibits the 'Clasping' Phenotype and is Smaller than its Wild-Type Counterpart

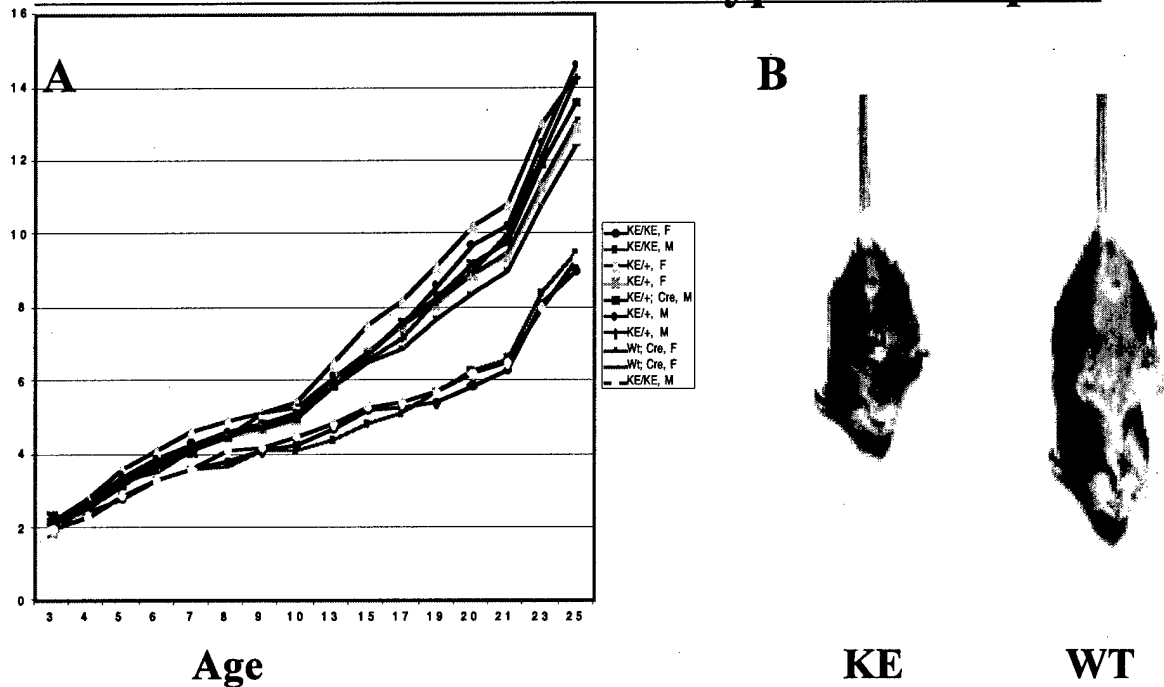

Figure 4. (A) A litter generated from heterozygous parents was weighed periodically over the first 25 days of life. KE/KE animals are substantially smaller than Wt/Wt or Wt/KE littermates. (B) When lifted by the tail, the normal response of the mouse is to spread its rear legs. The cyclin D1 KE mouse exhibits an abnormal 'clasping' phenotype similar to the cyclin D1 knockout mouse (not shown).

## Retinas and Mammary Glands From KE/KE Animals Show Only Subtle Developmental Defects

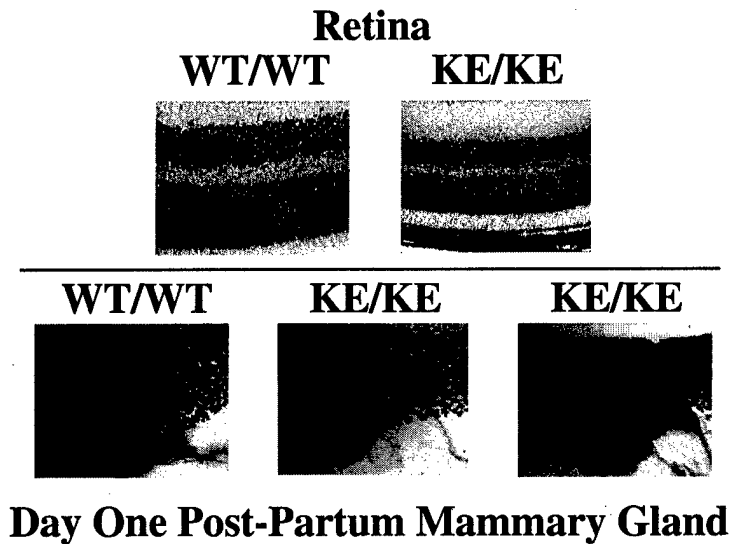

Figure 5. H & E staining of retinas from wild-type and KE mice show only subtle defects in organization and thickness. The wild-type section is cut at an angle resulting in the appearance of extra layers. Mammary glands were dissected from one day post-partum mothers, whole mounted and stained. The mammary glands from KE mice appear to develop in a relatively normal manner.

### Histology of Retinas From Mice which Underwent ERG

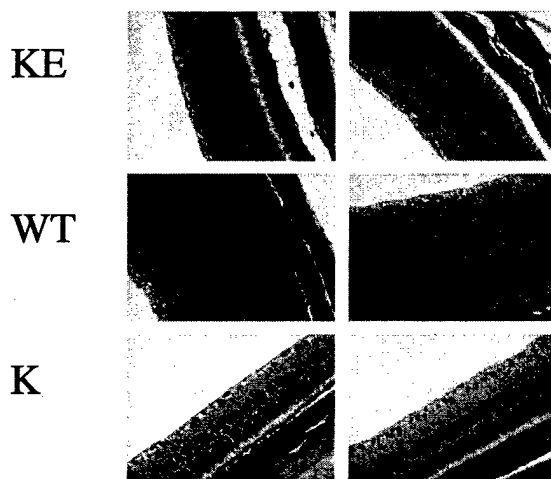

Figure 6. H & E staining of retinas from wild-type, and KE mice that underwent ERG. KO retinas are also shown for comparison.

# Quantitation Reveals that KE Retinas Function at Approximately 65-70% of WT Levels

Electroretinogram

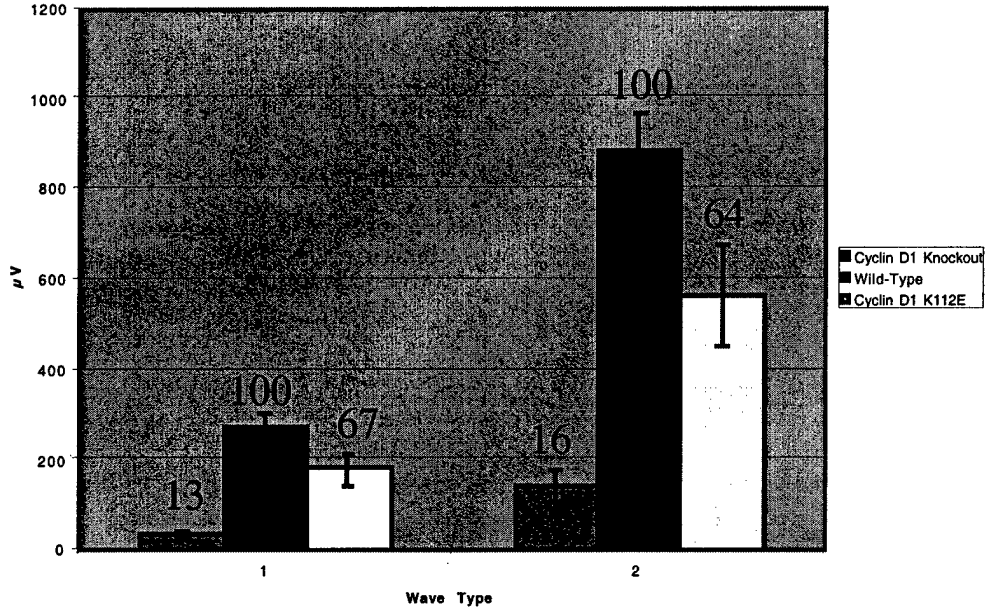

Figure 7. Quantitation of ERG data. The A wave is shown at left, B wave is shown at right. Wild-type values were set at 100%, KO and KE function is expressed as a percent of wild-type.

**Levels Of Cell Cycle Regulators In WT And KE  
E 14.5 Littermates**

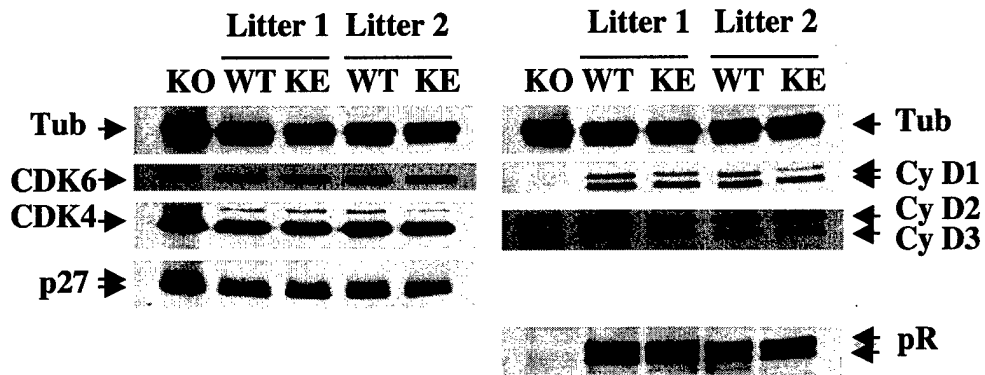

Figure 8. Levels of various cell cycle regulators were assessed by Western Blot analysis. Protein lysates were made from two pairs of wild-type and knock-in littermates. Levels of the different cell cycle regulators are equivalent in the wild-type and knock-in mice.

**Binding of CDK 4 to Cyclin D1 and KE**

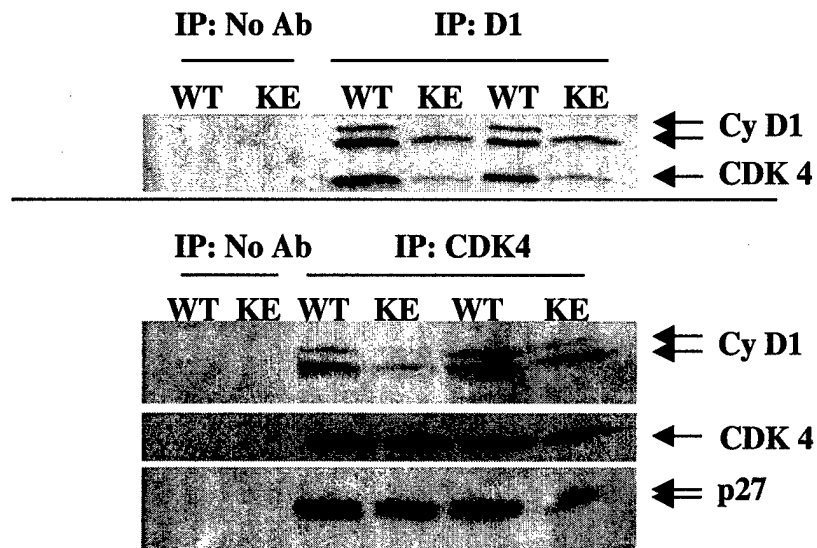

Figure 9. Proteins were immunoprecipitated from lysates with either D1 or CDK4 antibodies. Western blots were then probed for D1, CDK4 or p27.

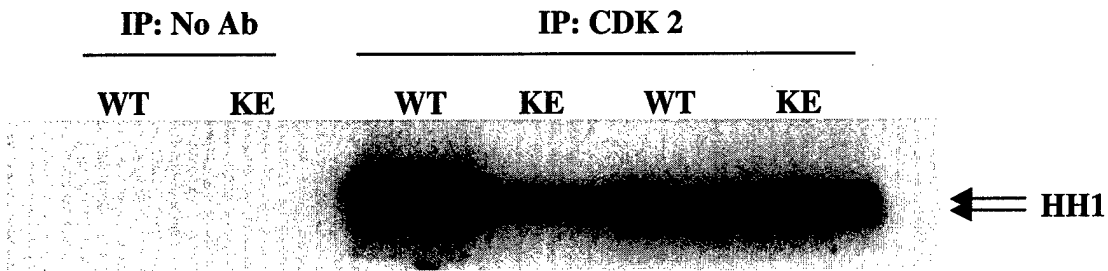

Figure 10. CDK2 complexes were immunoprecipitated from lysates and used to phosphorylate histone H1 in an in vitro kinase reaction.

### Levels Of Cell Cycle Regulators In WT And KE Retinas

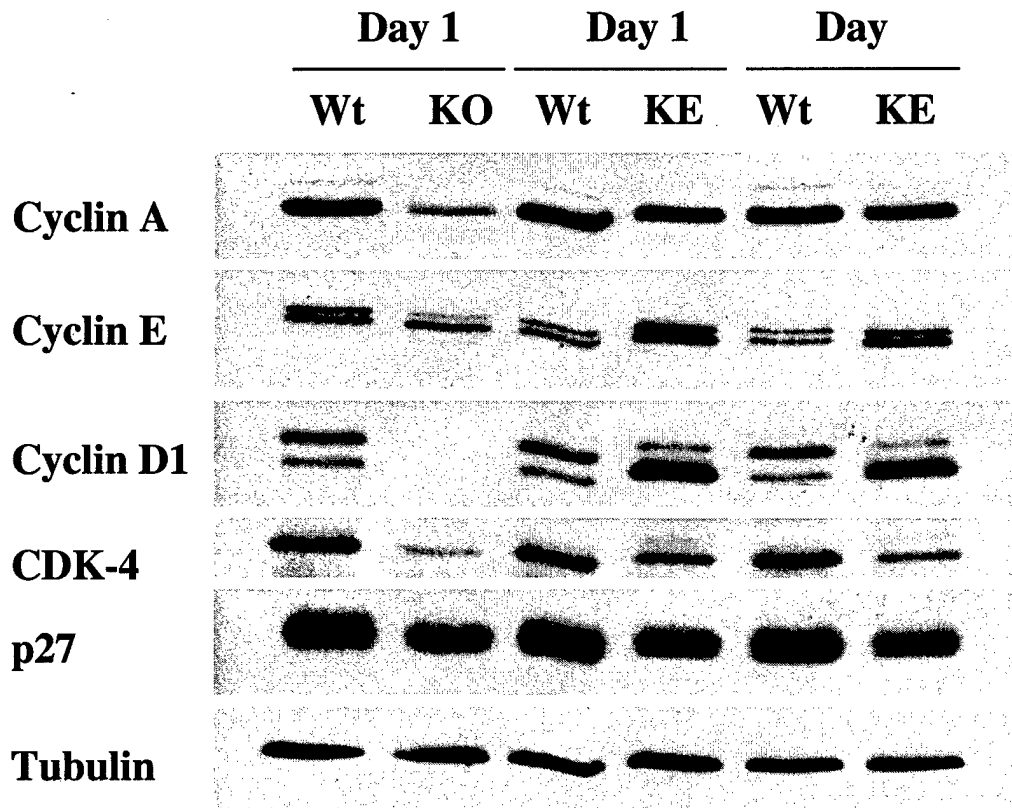

Figure 11. Levels of Cell Cycle Regulators in Wt, KO, and KE retinas. Levels of cyclins A, E, D1, CDK-4 and p27 in retina lysates are shown.

**Phosphorylation of pRb is Deficient in Both KO and KE Retinas**

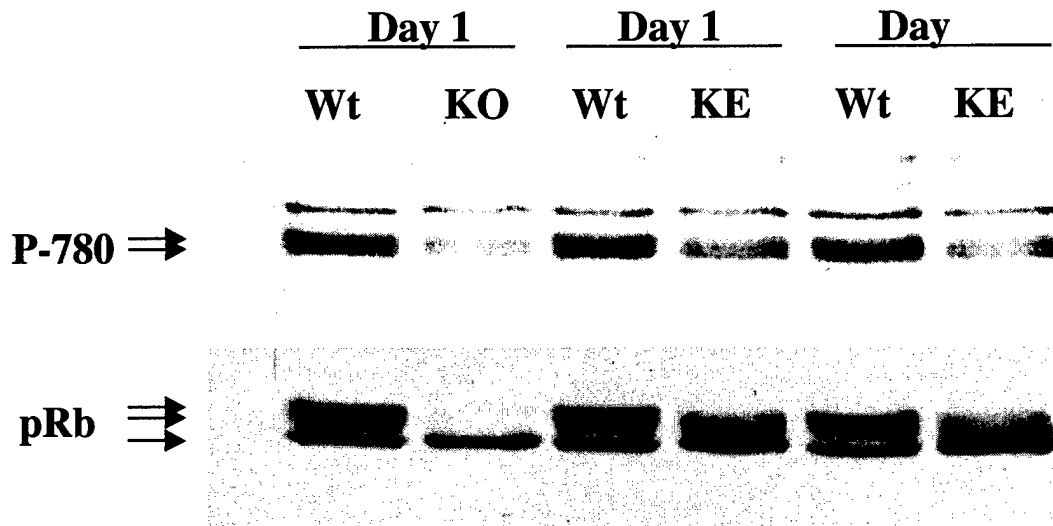

Figure 12. Western Blot of pRb from Wt, KO, and KE retinas analyzed with the phospho-780 specific antibody, and a pan-Rb antibody, which recognizes all forms of the protein. Phospho-780 signal is reduced in KO and KE retina lysates. In addition, phosphorylation of pRb as assessed by mobility is reduced in the KO and KE lanes in the pRb blot.

## Analysis of Serum IGF-1 Levels by RIA Demonstrates Differences Depending on Genotype

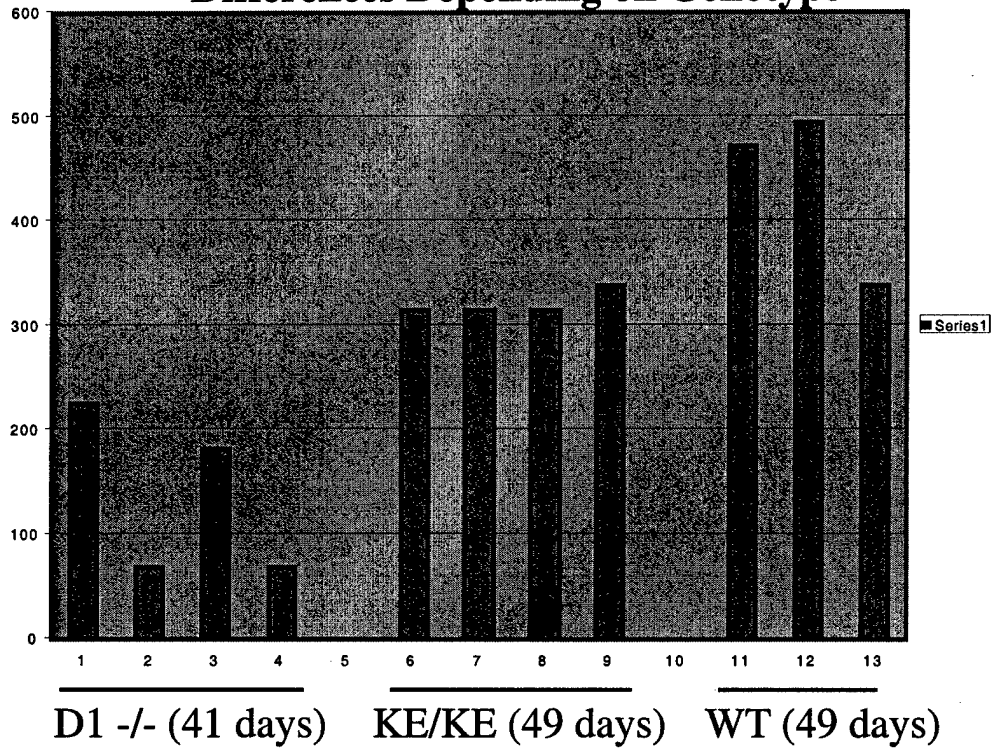

Figure 13. Analysis of serum IGF-1 levels by RIA. Each bar represents the level of IGF-1 in a particular mouse of the given genotype. Levels of IGF-1 in knockout animals were low compared to wild-type, with levels of IGF-1 in KE animals being intermediate.

## Cerebellar Development is Profoundly Defective in KE/D2-/- Double Mutant Animals

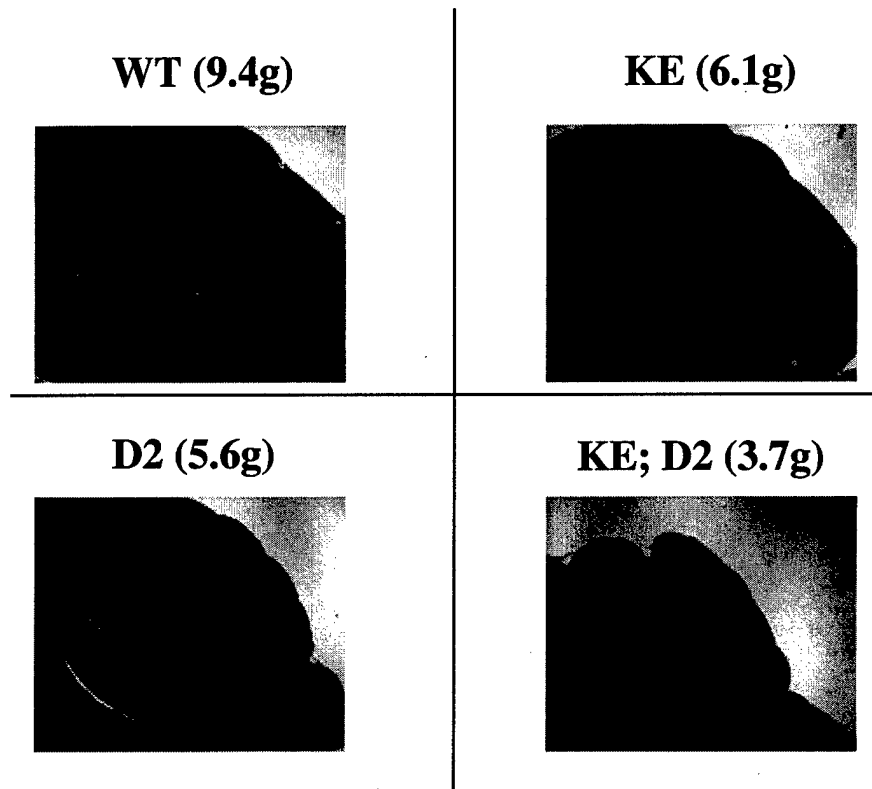

Figure 14. Cerebellar development in wild-type, KE, D2 KO, and KE/D2 animals. The weight of the mice at sacrifice is given in parenthesis after the genotype. The cerebellum of the KE/D2 mouse is profoundly deficient in size and the number of folia observed is smaller than in the other genotypes.