

AD _____

Award Number: DAMD17-00-1-0711

TITLE: International Rehabilitation Network

PRINCIPAL INVESTIGATOR: William Kennedy Smith, M.D.

CONTRACTING ORGANIZATION: Center for International Rehabilitation
Chicago, Illinois 60611

REPORT DATE: October 2003

TYPE OF REPORT: Annual

PREPARED FOR: U.S. Army Medical Research and Materiel Command
Fort Detrick, Maryland 21702-5012

DISTRIBUTION STATEMENT: Approved for Public Release;
Distribution Unlimited

The views, opinions and/or findings contained in this report are those of the author(s) and should not be construed as an official Department of the Army position, policy or decision unless so designated by other documentation.

20040121 062

REPORT DOCUMENTATION PAGE

Form Approved
OMB No. 074-0188

Public reporting burden for this collection of information is estimated to average 1 hour per response, including the time for reviewing instructions, searching existing data sources, gathering and maintaining the data needed, and completing and reviewing this collection of information. Send comments regarding this burden estimate or any other aspect of this collection of information, including suggestions for reducing this burden to Washington Headquarters Services, Directorate for Information Operations and Reports, 1215 Jefferson Davis Highway, Suite 1204, Arlington, VA 22202-4302, and to the Office of Management and Budget, Paperwork Reduction Project (0704-0188), Washington, DC 20503

1. AGENCY USE ONLY (Leave blank)		2. REPORT DATE October 2003	3. REPORT TYPE AND DATES COVERED Annual (29 Sep 02-28 Sep 03)	
4. TITLE AND SUBTITLE International Rehabilitation Network			5. FUNDING NUMBERS DAMD17-00-1-0711	
6. AUTHOR(S) William Kennedy Smith, M.D.				
7. PERFORMING ORGANIZATION NAME(S) AND ADDRESS(ES) Center for International Rehabilitation Chicago, Illinois 60611 E-Mail: Wsm460@nwu.edu			8. PERFORMING ORGANIZATION REPORT NUMBER	
9. SPONSORING / MONITORING AGENCY NAME(S) AND ADDRESS(ES) U.S. Army Medical Research and Materiel Command Fort Detrick, Maryland 21702-5012			10. SPONSORING / MONITORING AGENCY REPORT NUMBER	
11. SUPPLEMENTARY NOTES Original contains color plates. All DTIC reproductions will be in black and white.				
12a. DISTRIBUTION / AVAILABILITY STATEMENT Approved for Public Release; Distribution Unlimited			12b. DISTRIBUTION CODE	
13. ABSTRACT (Maximum 200 Words) Improving the quality of services for landmine survivors and other amputees in low-income countries is the primary goal of the International Rehabilitation Network (IRN). This is being accomplished through the dissemination of educational programs and electronic services to professionals in the rehabilitation field. The innovative use of information and telecommunications technologies, as well as computer-based training, facilitates the dissemination process. Through the IRN, the CIR links its research center and other centers of excellence in the rehabilitation field with rehabilitation centers in under-served, post-conflict regions with large populations of landmine survivors. In year 3, the IRN developed the additional multimedia training content in topics including Ischial Containment, Transhumeral Prosthetics and the Transtibial Socket Fabrication System. The IRN web portal functionality was enhanced and expanded, and a network of disability organizations in Latin America was created. Training was conducted in Central America and the Balkans, with the addition of five new rehabilitation centers and 22 new students, for a total of 75 students actively participating in the Distance Learning Program.				
14. SUBJECT TERMS Distance Learning, Amputee, Rehabilitation Professionals, Database			15. NUMBER OF PAGES 243	
			16. PRICE CODE	
17. SECURITY CLASSIFICATION OF REPORT Unclassified	18. SECURITY CLASSIFICATION OF THIS PAGE Unclassified	19. SECURITY CLASSIFICATION OF ABSTRACT Unclassified	20. LIMITATION OF ABSTRACT Unlimited	

Table of Contents

Cover.....	
SF 298.....	
Table of Contents.....	
Introduction.....	1
Body.....	1
Key Research Accomplishments.....	27
Reportable Outcomes.....	27
Conclusions.....	28
References.....	None
Appendices.....	30
Appendix A – CIR/CNR Action Plan	
CIR/CNR MOU	
Special Topics Proposal	
Lower Extremity Orthotics course outline	
IRN Advisory Council Members	
Scope of Work for IRN Advisory Council	
Executive Summary of IRN Education Panel Meeting	
Appendix B – Spanish Regional Newsletter (English and Spanish)	
Appendix C – ISPO Workshop Plenary discussion summary	
Appendix D – Gradina Prosthetic Center MOU	
MOU with Ministry of Martyrs and Disabled (MMD)	
Action Plan for Ministry of Martyrs and Disabled	
Appendix E - IDRМ Research Guide	
Regional Training Workshops materials	
IDRM Website pages	
Appendix F – Course evaluation results from students and mentors	
Campus Virtual Application	
Appendix G – List of Distance Learning Training Centers	
Appendix H – Sample Modules from New Module Sets	
Transhumeral Prosthetics Module Set	
CIR Casting System Module Set	
Ischial Containment Module Set	

INTRODUCTION

The Center for International Rehabilitation is the contractor for the International Rehabilitation Network (IRN). The Principal Investigator is William Kennedy Smith, M.D. Improving the quality of services for landmine survivors and other amputees in low-income countries is the primary goal of the IRN. This is being accomplished through the dissemination of educational programs and electronic services to professionals in the rehabilitation field. The innovative use of information and telecommunications technologies, as well as computer-based training, facilitates the dissemination process and links the CIR and its research center with other rehabilitation centers of excellence in the U.S. and internationally.

BODY

Accomplishments associated with the approved Statement of Work (SOW):

SOW # 1: The Center for International Rehabilitation (CIR) web-based training curriculum for those providing rehabilitation services to land mine survivors and other amputees will be expanded to include courses in ischial containment and CIR socket fabrication techniques, trans-humeral prosthetics, lower extremity orthotics, and pain management. The CIR will finalize the design of a three-year curriculum for a degree in prosthetics and orthotics, and will further develop content for this curriculum in partnership with universities in Latin America, Europe and Asia/Australia.

Background

The CIR is currently conducting a Distance Learning program that provides continuing education for rehabilitation professionals. The features of the Distance Learning program are as follows:

1. Multiple learning modalities including textbooks, electronic media, internet facilitated communication and in-person training. The blended use of these modalities supports active learning via participation in workshops, projects, labs, tutorials, lectures and simulations.
2. An Advisory Panel of instructional experts who assist with the refinement and expansion of educational content.
3. Interactive learning strategies and participant dialog through the use of communication tools including chat rooms, bulletin boards, and conferencing.
4. Utilization of online mentors facilitating real-time interactivity and individualized instruction.
5. Participation, by trainees and other rehabilitation and medical professionals, in the development of course content in the form of case studies. These case studies are stored in the CIR's digital archive. They provide an overview of many of the challenges involved in providing services to landmine survivors and other

amputees in land mine effected countries, as well as some useful strategies employed in meeting those challenges.

6. On-site follow-up and verification of skill transfer and utilization leading to continuous refinement and strengthening of the Distance Learning program.

Project Update

Curriculum Development

A) During this reporting period the CIR has developed the following modules:

1) Ischial Containment Module Set (English and Spanish)

Module I	Basic Lower Extremity Anatomy
Module II	Prosthetic Patient Evaluation
Module III	Prosthetic Casting Technique
Module V	Modification of Positive Mold
Module VI	Bench Alignment
Module VII	Fitting

2) CIR Casting System for Transtibial Prosthetic Socket (English and Spanish)

Module I	CIR Casting System Overview
Module II	CIR Casting Station Assembly
Module III	CIR Casting Station Set Up and Testing
Model IV	Casting the Transtibial Socket

3) Transhumeral Module Set

Module I	Basic Upper Extremity Anatomy
Module II	Prosthetic Components and Selection Criteria
Module III	Patient Prosthetic Evaluation
Module IV	Transhumeral Socket Design: Principles, Measurements, and Casting Techniques
Module V	Cast Modification
Module VI	Check Socket Fabrication and Evaluation
Module VII	Materials Used in Plastic Lamination
Module VIII	Lay-Up and Plastic Lamination
Module IX	Fabrication Procedures
Module X	Trimming, Assembly, and Harnessing

See sample modules from each of the above module sets are found in Appendix H

B) The CIR is currently developing content in the following areas:

- a) (CIR) Biomechanics for Prosthetics (Spanish. Course design in process)

b) (CIR) Shape and Roll Foot

C) The CIR, cooperation with the National Rehabilitation Center (CNR) of Mexico, is currently developing educational content.

The CIR has established a partnership with the National Rehabilitation Center (CNR) of Mexico to develop and disseminate educational materials in prosthetics and orthotics. The CIR has conducted training sessions with CNR's technical staff in Mexico City on the process of developing content, graphics, video, curriculum, evaluation tools, on-line conferences and case presentations. In addition to prosthetic and orthotic content, the CNR will develop an on-line module set covering basic computer skills and frequently asked questions (FAQ). Please refer to Appendix A for a copy of the Action Plan, course outlines, and the Memorandum of Understanding between CIR and CNR. Specific content areas include the following:

- a) Lower Extremity Orthotics (Spanish) A draft course design, including topics for instruction, has been developed by CNR and CIR. Please refer to Appendix A for course design document.
- b) Upper Extremity Orthotics (Spanish) A draft course design, including topics for instruction, has been developed by CNR and CIR.
- c) Spinal Orthotics (Spanish – Course design in process)
- d) FAQ & Basic Computer Skills

D) Modules completed prior to this reporting period include:

- a) Computer Training and WebCT Tutorial (English, Spanish)
- b) Transtibial Module-Set (English, Spanish and Bosnian)
- c) Transfemoral Module-Set (English, Spanish and Bosnian)
- d) Transradial Module-Set (English, Spanish)
- e) Transfemoral Module-Set (English, Spanish)
- f) Outcome Measures Module-Set (English, Spanish)

E) Additional educational content is being developed on the following special topics:

- a) Pain Management for Landmine Survivors
 - Module 1: Acute pain management
 - Module 2: Sub acute pain management
 - Module 3: Optimization of chronic pain incidence

Status: The CIR in cooperation with the Pan American Health Organization (PAHO) proposes to develop the content for this module at a second regional CIR Network conference to be held in the spring of 2004 in Managua Nicaragua. PAHO and CIR will work with pain management experts and other rehabilitation specialists over the three day course of the conference to develop content using PowerPoint as the primary authoring tool. (See proposal in Appendix A)

- b) Landmine Casualty Stabilization and Evacuation

Status: Course is in early development. Subject matter expert and review team assignments for this course are pending

- c) Life and Limb Saving Surgery:

Status: Course is in early development.

The CIR has created an Advisory Council to provide technical assistance in all aspects of content and program development. The council consists of three panels: Education, Platform and Instructional Design.

Specific functions of the International Rehabilitation Network's (IRN) Advisory Council include:

- Preparing Advisory Council Progress Reports
- Providing guidance to the CIR's Distance Learning Program in the areas of technology, instructional design and educational content
- Providing guidance in the development of a Three Year Distance Learning Degree Curriculum in Prosthetics and Orthotics
- Overseeing student Entry/Exit Evaluations
- Creating Guidelines for Content Review

CIR's Advisory Panel on Educational Content provides guidance in the development, review and evaluation of prosthetics and orthotics educational content in order to:

- Ensure clarity of educational goals of programs according to International Society of Prosthetics and Orthotics guidelines
- Ensure course materials are appropriate for distance education
- Assist with the development of student evaluation tools
- Assist with the tailoring of content to meet the needs of different audiences
- Suggest and evaluate clinical presentations

CIR's Advisory Panel on Educational Content continues to play an active role regarding in formative and summative stages of the development cycle for prosthetics, orthotics, and non-P&O curriculum. A meeting of the Education Panel was organized and held in San Salvador the 13th of December 2002. (see Appendix A for a list of Advisory Council members and a copy of the Education Panel report). Mr. Sepp Heim, President of the International Prosthetics and Orthotics Society (ISPO) serves in the role of chair of the education panel and provides advice to the CIR on international standards relating to prosthetic curriculum development issues. Mr. Heim and the advisory panel on educational content have completed their review of the Transtibial and Transfemoral module sets of the Lower Extremity Prosthetics course. Additionally, the CIR has developed a common standard for the evaluation of practical skills of prosthetists.

Please see Appendix A for additional details on this Council.

E) Conferences

The CIR has engaged in a number of conferences to present on the findings of IRN research and the Distance Learning program. Increasing interest among professional communities in distance learning continuing education has presented a number of opportunities for the IRN project to be highlighted. The following are some examples of CIR workshops and presentations:

Smith, W. K. (2003). A pilot continuing education program in lower extremity prosthetics via distance learning. Army Telemedicine Partnerships 2003: Meeting medical challenges in a changing world. Orlando, FL.

Smith, W. K. (2003). CIR web-based distance learning for prosthetic technicians in Central America - a pilot program. International Society of Prosthetics and Orthotics (ISPO) Central European Conference. Dubrovnik, Croatia.

Potts, M.K., Smith, W.K., Edwards, Z., & Chatterton, P. (2003). CIR distance learning in Bosnia and beyond. Paper presentation at the 2003 Annual WebCT Users Conference. San Diego, CA.

Wortham, D.W., Potts, M.K., & Casanova, H.R. (2003). Visualizing the Community of Learners Using Social Network Analysis Techniques. Division C paper session on learning environments. American Education Research Association Annual Meeting. Chicago, IL.

Casanova, H.R. (2002) CIR web-based distance learning for prosthetic technicians in Central America - a pilot program at the "International Society of Prosthetics and Orthotics Workshop on Prosthetics and Orthotics Training Institutes in Non-industrial Countries" San Salvador, El Salvador (See a copy of the plenary discussion summary in appendix C).

In September 2003 the CIR participated in the World Health Organization (WHO) review of the "Guidelines for Training of Personnel in Developing Countries" in Glasgow, Scotland. This workshop relating to prosthetic/orthotic training was an important opportunity for the CIR to highlight the findings and progress of the IRN project and its use of telecommunication strategies for distance learning. Attendees included representatives from the World Health Organization (WHO) Rehabilitation Unit, International Committee of the Red Cross (ICRC), Handicap International (HI), members of the International Society for Prosthetics and Orthotics (ISPO) Executive Board, United States Agency for International Development (USAID), Cambodia Trust, Tanzania Training Center for Orthopedic Technologists (TATCOT), Vietnamese Technology Center for Orthopedic Technologists (VIETCOT), Don Bosco University (El Salvador), PIPOS (Pakistan), Strathclyde University, and other NGO's involved in prosthetics and orthotics education in the developing world. CIR was the only NGO represented from the United States.

The CIR attended and helped moderate a panel on rehabilitation and reinsertion of landmine survivors in the Central American region, during the "Closing Conference of the Tripartite Agreement" (Mexico, Canada & the Pan-American Health Organization - PAHO) in Nicaragua from March 3rd to 7th, 2003.

The CIR organized training workshops on the collection and reporting of disability data in El Salvador (January 13th to 14th, 2003), Nicaragua (January 16th to 17th, 2003) Ecuador (April 7th to 8th, 2003), and New York (June 15th to 19th, 2003). Attendees included leaders from disability organizations in the two regions (the Americas and Asia Pacific), and topics of instruction included identifying the need for data collection, directions on use of the questionnaire, disability rights, and report writing, among others. The workshops were in support of the creation of a regional network of disability researchers. Please refer to SOW #4b for more information.

Platform Development

The CIR maintains an integrated, secure web platform to facilitate distance learning, data collection, storage and reporting as well as communication between the clinics and hospitals participating in the Center for International Rehabilitation Network (CIRN).

Platform Design

The CIR took a number of steps in the past contract year to upgrade and expand the data collection and reporting functions of its web platform. A new partnership has resulted in the CIR web servers being maintained by Northwestern University, which enhances technical support capacity in a cost-effective manner. In addition, the CIR has implemented two important changes to its platform design.

First, the Center has shifted its programming language from Java to Cold Fusion in order to speed the development of web applications. During the past contract year the CIR

engaged in a partnership with a private software development firm, Control Room Technologies (CRT), to expand and integrate the functionality of the CIR web platform to better disseminate electronic services. CRT uses Cold Fusion as its primary programming language. The partnership with CRT and the introduction of Cold Fusion has resulted in improved functionality of the website's integrated login framework for network users and integration of the CIR's online directory of rehabilitation centers. As of the end of the reporting period, CRT and CIR were finalizing a remote data entry and reporting functionality on the site, with an expected completion date in Fall 2003.

Second, the database application has shifted from MySQL to Oracle, the leading commercial database product. The upgrades will help ensure reliable and efficient network services on a global scale. In addition, an Oracle database will enable CIR through its partnership with WebCT to install, free of charge, the latest version of WebCT software entitled Vista.

This grant year the CIR migrated from WebCT 3.1 to WebCT Campus Edition 3.8. Benefits of this version include Section 508 compliance for accessibility to the widest audience, drag-and-drop content acquisition, management of cross-listed courses, multi-language capabilities (including support for Unicode), support for failover, and randomized display of answers to multiple-choice questions for enhanced quiz security.

The need for users to be online while they are engaging course content or the various communications tools (e.g., online chat, discussion boards) and the lack of availability of WebCT email outside the login framework of online courses presents an ongoing challenge for the Distance Learning program.

The current version of WebCT Vista (v2.1) has been designed to support SCORM 1.2 specifications, allowing course designers to import SCORM packages for use with the software. Additional functionality enabled within WebCT Vista include a single-sign-on (SSO) framework to support authentication to Vista from other applications, learning object import, gradebook auditing, and section archiving.

The platform has two primary functions, distance learning and data management.

1) Distance Learning

The CIR has entered into a cooperative agreement with WebCT to develop the first ever Serbo-Croatian (Bosnian dialect) language plug-in for WebCT's Campus Edition 3.8. CIR is currently engaged in the process of upgrading this language plug-in for adaptation to our new Campus Edition version of WebCT (version 4.1). This plug-in has enabled the CIR to deliver WebCT-based content using a Serbo-Croatian language interface for navigation and help files, and can be made available to all users of the Web-CT platform, enabling other WebCT users to leverage this regional capability of the WebCT platform as an additional benefit of CIR's distance learning development activities.

WebCT runs on our web server and gives students access to course content as well as the means to interact with instructors and each other. We are currently evaluating the next version of WebCT's Campus Edition (version 4.1) to improve students' learning experience and are negotiating an evaluation and upgrade path for WebCT's Enterprise-level learning platform called Vista (version 2.1).

2) Data Management: Data collection, Storage and Reporting

In the past reporting period, the CIR implemented a number of enhancements to its web platform and databases to expand capacity and functionality in support of the collection and dissemination of information to users serving landmine survivors and other people with disabilities in low-income countries. Through a partnership with private software developer Control Room Technologies (CRT), the CIR was able to improve the web interface for rehabilitation professionals, researchers, and the general public to access online information and services, including the distance learning program. An online registration system was developed for users and organizations to register with the IRN and to enable their access to certain services, including a tool to authenticate users for the distance learning program. On the administration level, a security framework, a page content management system, a user management area and an Outcomes reporting tool were developed.

Currently, data entry and reports are protected during transmission over the Internet using SSL, an industry standard protocol that incorporates encryption and verification to ensure the confidentiality of the data. Access is granted only to accounts specifically approved by CIR. Servers are protected by a firewall and operating system software is regularly updated to prevent unauthorized access. All data is stored in an Oracle 8i relational database with restricted access. This means the data can be queried and reports can be generated using standard tools.

Rehabilitation Directory

CIR makes available on the web a directory of rehabilitation centers that are part of the network. This directory includes contact information such as address, phone number as well as information about what services are offered. The directory is public so that land mine survivors and other amputees as well as people working in the rehabilitation field can find centers of interest to them. Work continues to ensure that centers can keep their own data current and to add organizations to the directory.

Disability Data Survey

Social science data pertaining to the condition of people with disabilities is being gathered through the network. An online function is being developed to allow remote entry of data onto the CIR web portal to be stored on the CIR archive. The data will be used to create a report on the condition and rights of people with disabilities and how they vary culturally and geographically.

3) Requirements for Remote Sites

On the receiving end, at the clinics, all students are required to have access to a PC with a minimum of 400-megahertz processor, CD-ROM, and at minimum 33K modem Internet access. Mandatory software on the student side consists of an Internet browser and word processing package. All software used by students is commercially available off-the-shelf and no custom or proprietary software has been installed at the centers participating in the program.

SOW #2

a) Training in lower extremity and upper extremity prosthetics in Central America will continue at the 11 centers currently participating, as well as at up to 5 additional centers in Honduras. Training in transradial and transhumeral prosthetics will be initiated in Central America. Field research on simplified prosthetic alignment techniques for land mine survivors and other amputees will also be conducted in Central America.

Background

The CIR has continued to expand its network of rehabilitation service providers, universities and people with disabilities in Latin America. The goal is to provide assistance through training and education, data collection and dissemination and the transfer of appropriate rehabilitation technology.

Project Update

Latin America

The CIR's Distance Learning program is designed to deliver continuing education to prosthetic technicians working at existing rehabilitation centers in mine affected countries. These technicians have, for the most part been trained "on the job", and for various reasons have been unable to access formal university-based prosthetic and orthotic education programs.

Regional Partnerships - As mentioned under SOW #1, the CIR has formalized a partnership with Mexican National Rehabilitation Center (CNR). Through this strategic partnership, content in the area of lower and upper extremity orthotics as well cervical and spinal orthotics is being developed. In addition, the CNR will play an important role in the dissemination of the CIR's Distance Learning Program by actively participating in workshops, hosting on-line conferences, and participating in the training program. The CNR has identified prosthetic and orthotic faculty members who will work closely with CIR staff to conduct regional training and research activities, and provide input for the further refinement of IRN products and activities.

Education / Dissemination – The CIR has expanded its education and training activities in Latin America to include additional students and affiliated centers.

The CIR continues prosthetics training via distance-learning with the original pilot group of 22 students in 11 rehabilitation centers located in 3 countries (Nicaragua, El Salvador and Guatemala). This group of students began their training in 2001, and has completed Transtibial, Transfemoral, Transradial, and Ischial Containment Module Sets. In November 2003, the group will begin the recently developed Transhumeral course.

This original group of students will continue to serve as a "pilot group" for the initiation of new training content and methodologies. For example, ten students from this pilot group were chosen to participate in a one-week training program using Northwestern University Prosthetic and Orthotic Center's (NUPOC) techniques in Ischial Containment socket fabrication. The students chosen were trained at a workshop in San Salvador that covered the following topics: hand casting, modification, fabrication, and dynamic alignment.

In addition, in the current reporting year the CIR has added a second group of students in Latin America consisting of 22 prosthetic/orthotic technicians from 16 centers, of which 5 are new affiliates to the IRN. Of these new affiliates, three are in Honduras, a country not previously covered by the IRN network. This group has so far completed their theoretical and practical entry evaluation of the Transtibial Module Set. Results follow in SOW #3.

Newsletter - The CIR has developed and distributed a Spanish-Language Newsletter in Latin America that is intended to highlight those activities of the IRN project that are relevant to the rehabilitation, health care and disability communities. The newsletter is disseminated in both electronic and print format. Over 1,000 copies have been distributed to date, 900 of the printed version and 351 electronic copies. The content includes articles on consumer related topics as well as training and engineering activities. It will also include technical briefs that will be based on case presentations and/or on-line conferences developed by prosthetists/orthotists participating in the on-line distance-learning program. See Appendix B for a copy of the most recent newsletter.

Rehabilitation Resource Directory - The CIR Resource Directory is an index of rehabilitation service providers in the Central American region that can assist people with disabilities and rehabilitation professionals. The directory is available in printed format as well as online via the CIR website (please see SOW#1 for an update on the functionality of the online directory). The directory is currently being updated and expanded to include two more countries affected by landmines in Central America (i.e. Honduras and Costa Rica). A total of 544 organizations providing services to landmine survivors and persons with disabilities have been identified and basic information regarding their existing programs is included. The CIR Resource Directory is publicly accessible at the following URL:

<http://banmines.org/DB/Database.ASP>

Degree Programs

The CIR is developing a three-year degree curriculum in prosthetics and orthotics and an international consortium of educational centers to jointly develop distance learning content in prosthetics and orthotics. International Society of Prosthetics and Orthotics (ISPO) President Sepp Heim will oversee the final student evaluation for the lower extremity prosthetics course currently underway in Bosnia. It is anticipated that Mr. Heim's upcoming visit and participation in the final practical evaluations of students studying the Lower Extremity Prosthetics module set in Bosnia will facilitate ISPO recognition of CIR's lower extremity curriculum for incorporation into a potential degree program.

b) Training in lower extremity prosthetics will be conducted with 13 rehabilitation centers in Bosnia, and field research on the CIR socket casting technique will also be conducted in the Balkan region.

Balkan Region

As a result of the war in Bosnia and Herzegovina, this region has the highest amount of contaminated land due to land mines and unexploded ordinance in all of Europe.

The U.S. State Department reports that over 500,000 unmarked land mines and other unexploded ordnance (UXO) remained throughout Bosnia and Herzegovina after the war, and over 300 people have been killed by these devices since 1996. While most urban areas have been largely cleared, special care should be taken when near former lines of conflict, including the suburbs of Sarajevo¹.

The International Campaign to Ban Landmines (ICBL) reports that in 2002, landmine/UXO incidents killed 26 civilians and injured 46 others, including 19 children, representing a decrease from the 87 new casualties reported in 2001. Males accounted for 90 percent of reported casualties. Mines were the cause of 40 casualties, 28 were caused by UXO, two by improvised explosive devices and the cause of two casualties was unknown. Landmines and UXO continued to cause casualties in 2003, with 13 civilians killed and 14 injured up to 9 May 2003. In an incident on 10 March 2003, five members of one family were killed in northern Bosnia after the son stepped on a landmine while clearing a field. The family had recently returned to their village after fleeing during the

¹ U.S. Department of State, Bureau of Consular Affairs, Washington D.C. 20520, Consular Information Sheet, <http://travel.state.gov/bosnia-herzegovina.html>, Accessed, Wed. Oct 15, 10:54:17 2003,

² International Campaign to Ban Landmines, Landmine Monitor, www.icbl.org/lm, Landmine Monitor Report 2003, Accessed, Oct 15, 11:32 2003

1992-1995 war.² The population is, in many cases, aware of the existence of mines and the danger they pose, but all do not practice safe behavior mainly due to the economic necessity of cultivating the land, although other factors also come into play. As of 9 May 2003, the ICRC database contained information on 4,798 landmine/UXO casualties since 1992, of which 927 were killed and 3,871 injured. Between 1996 and 2002 the mine incident rate fell from an average of 52 casualties per month to six casualties per month. An analysis of the type of injury sustained indicates that from 1992 to the end of 2002, there were 2,274 amputations, 411 eye injuries, and 2,691 cases of fragmentation wounds, with some individuals sustaining multiple types of injury.

The CIR has been working in Bosnia and Herzegovina (BiH) since August 2002 with its main office located within the Gradina Prosthetic Center in Tuzla, Bosnia. By operating in close collaboration with the Tuzla Center, the CIR staff are able to work with the Director of the Prosthetic and Orthotic (P&O) services and other P&O staff to provide upgrade training in Prosthetics and Orthotics to 27 technicians working in 12 rehabilitation centers throughout Bosnia and Herzegovina, the Republika Srpska and Slovenia.

The CIR educational program designed for the Balkans provides upgrade training for technicians who have been working as Prosthetic and Orthotic professionals for 3-5 years. The CIR educational program provides these professionals with a structured and formal education that is intended to improve their technical skills in P&O. Until the IRN program in Bosnia, there was no formal education program available to P&O professionals.

Partnerships

On January 8, 2003 CIR engaged in an agreement with the Gradina Prosthetic Center in Tuzla that will allow the CIR the use of its facilities for office and technical space to assist in the implementation of the distance learning program, conferences and clinical workshops. (see MOU in Appendix D).

The CIR is in active dialogue with governmental Ministries of Health and Education to facilitate a process for formal accreditation by the government of P&O training programs, and the Ministry of Education has appointed a liaison to work with the CIR and review CIR's curriculum for possible incorporation into a national curriculum for P&O.

In addition, the CIR has been coordinating with agencies and organizations that are active in the Balkan region, including the Organization for Security and Cooperation in Europe (OSCE), Landmine Survivors' Network (LSN), Handicap International (HI), and the

1 U.S. Department of State, Bureau of Consular Affairs, Washington, D.C. 20520, Consular Information Sheet, <http://travel.state.gov/bosnia-hergovina.html>, accessed, Wednesday Oct 15, 10:54:17 2003.

2 International Campaign to Ban Landmines, Landmine Monitor, www.icbl.org/lm, Landmine Monitor Report 2003, Accessed, Oct 15, 11:32 2003.

United Nations' Children's Fund (UNICEF). This coordination has been primarily related to coordinating services and exchanging information related to education and landmine survivors. Recently the CIR has been approached by HI to assist them in a survey throughout Bosnia and Herzegovina to gather information from P&O centers on landmine survivors. The CIR agreed to assist HI with their UNICEF funded survey as the statistical data derived from such a survey will also benefit the CIR's programs.

Education and Dissemination

Twenty six students completed the first course in lower extremity prosthetics, covering Transtibial prosthetics, in September 2003. The Transfemoral course convened during the end of September and its completion is anticipated by February with the final evaluation for Lower Extremity Prosthetics expected to convene in late February 2004 or early March 2004. The final evaluation for Lower Extremity Prosthetics will be attended by representatives from ISPO, who will assess the skills and knowledge of the students. Students in the region who successfully complete the Lower Extremity Prosthetics courses will participate in training in Upper Extremity Prosthetics, which will include module sets in Transradial Prosthetics and Transhumeral Prosthetics, both adapted for the region.

c) The CIR will collaborate with the Government of Afghanistan to develop training and capacity building activities for service providers assisting land mine survivors and other war wounded in Afghanistan.

The CIR continues to work closely with the Minister of Martyrs and Disabled (MMD) of the Government of Afghanistan through a partnership focused on technical assistance. Under an MOU (see Appendix D), the CIR and the MMD collaborate to identify regional needs, provide technical and administrative support to the MMD, and coordinate regional activities. With assistance from the IRN project, an advisor is provided to the MMD full time. The MMD advisor assists the CIR in reporting activities related to the disabilities legislature in Afghanistan, assesses potential partners for the CIR in the field, establishes communication for the CIR with International Non-government Organizations (INGO's) and Non-Governmental Organizations (NGOs) and assists with information related to funders and future proposals.

In April 2003, the CIR conducted a 20-day assessment in Kabul Afghanistan in coordination with the Ministry of Martyrs and Disabled (MMD). This assessment trip's goal was to make preliminary plans for the implementation of the wheelchair project which is focused on creating a wheelchair that can be used in the difficult terrain of many developing countries, is affordable and is relatively simple to assemble and repair. The trip was also necessary to assess the potential for a national upgrade curriculum in Prosthetics, Orthotics and Assistive Technologies.

d) The CIR will conduct a mission to Tanzania, Ethiopia and Eritrea to evaluate the region for possible IRN program activity.

Program Update

Over the past reporting cycle, the CIR has been in contact with the Tanzania Training Center for Orthopedic Technologists (TATCOT) regarding potential joint activities. As a result, the CIR has made plans to conduct a mission to Tanzania, as well as Ethiopia and Eritrea, in Spring of 2004 to pursue and implement these proposed activities, which are outlined below:

CIR will be conducting an ISPO-sponsored training workshop on the CIR Sand Casting system at TATCOT for 22 participants from several countries and multiple INGO's such as Handicap International and the ICRC, during the week of April 19, 2004. The workshop will start with distance learning for disseminating basic information regarding the new CIR technology a month or two prior to the TATCOT workshop. The weeklong on-site workshop will focus on clinical applications. At this time, CIR plans to send two staff to provide training while ISPO will assist and monitor the technology transfer.

During the assessment mission, the CIR staff will tour the African Medical Research Foundation (AMREF) Distance Learning Facility, which offers courses in various sectors of the medical field but does not provide courses in prosthetic education. The AMREF facility has satellite programs in Eritrea and Ethiopia that are of particular interest to the CIR, as both countries have a significant number of land mine victims. The CIR will discuss with AMREF the possibility of coordinating distance learning courses through its main facility extending to Eritrea and Ethiopia.

e) Data from the projects will be used to examine the feasibility and cost-effectiveness of (i) commercially-available Web-based courseware coupled with hybrid CD-ROMs for the delivery of continuing prosthetics education and (ii) the ability of Plain Old Telephone Service (POTS), ISDN and wireless technologies and devices to support continuing education to those providing services to land mine survivors and other war-wounded.

The CIR continues to evaluate the findings of its distance learning and electronic dissemination research on the basis of impact on the user groups and cost-effectiveness. The following is an update on CIR data and analysis regarding these evaluation criteria:

User Impact

Student Evaluations

At the conclusion of the Transtibial Prosthetics course in Bosnia, students were asked to rate the course on the following categories (Poor =1; Excellent = 5). Overall, the highest and most consistent ratings were given for the performance of the Instructor (CIR staff person Christian Schlierf), the organization and structure of the course, and the course content. The results were the following:

Student Ratings	Average student rating
Instructor	4.72
Your Mentor	3.94
Technical Support	4.27
Organization of the course	3.72
Content	4.17
Online chat	3.10

Students were also asked to rate each statement (Strongly Disagree = 1; Strongly Agree = 5). Overall, students indicated the greatest satisfaction with understanding the expectations of the course, technical support and use of the computer.

Student Response to Statements	Average Student Rating
The expectations were clearly stated for the Transtibial/Transfemoral course.	4.22
I was pleased with my interactions with my mentor.	3.89
I received adequate support from the regional technical support personnel.	4.11
I was comfortable using the computer for this course.	4.28
I was able to spend as much time as needed using the computer for this course.	4.22

Mentor Evaluations

In addition, the mentors were asked to rate the course in the following categories (Poor = 1; Excellent = 5). The mentors gave the highest ratings for technical support and the design of the educational materials. The instructor and educational content received high marks as well. The results are summarized below:

Mentor Ratings	Average student rating
Instructor	4.5
Technical Support	4.0
Organization of the course	3.5
Content	4.0
Design layout of online materials	4.0
Online chat	3.5

The mentors were also asked to respond to the following statements. In general, mentor responses indicated a high comfort level with computer use, time with the students and technical support.

Mentor Response to Statements	Average Student Rating
The amount of work for mentors was... (Far Too Light = 1; Far Too Heavy = 5)	3.5
The mentor's role with regard to students was clearly defined. (Strongly Disagree = 1; Strongly Agree = 5):	4.0
Mentors were given adequate directions before and during the courses.	3.0
I was pleased with my interactions with the instructor.	4.5
I received adequate support from the regional technical support personnel.	4.5
I was comfortable using the computer for this course.	3.5
I was able to spend as much time as needed with students for this course.	4.5

The completed course evaluation results from students and mentors are included in Appendix F of this report, including individual student and mentor responses to open ended questions such as the following:

- What did you learn in this course that was most helpful?
- To improve this course, what areas of this course were most confusing or which topics would you like more information about?
- What changes would you make for the next course?
- Additional comments and suggestions?

Student Performance

Distance Learning students are evaluated using the following criteria:

1. Completing written entry and exit examinations.
2. Following completion of each online module, quizzes are administered online to each participant. Students must achieve a score of 70% or better in order to proceed to the next module.
3. During the course, each participating rehabilitation center must submit one Case Presentation.
4. Each student must prepare one Technical Brief during the course.
5. Hands-on practical workshops are utilized to measure individual student progress.

6. Participation in chat room and bulletin board discussions is also required of each individual student throughout the course.

As of the end of the grant reporting term (September 28, 2003), all but one of the current student cohorts in Bosnia had completed the requirements of the Transtibial Prosthetics course. All students were required to complete requirements for their Technical brief submissions prior to entry into the next, Transfemoral Prosthetics course.

The average student performance scores on the practical examinations and written examinations of the Transtibial, (Bosnia and Latin America) and Transradial Prosthetics course (Latin America) were as follows:

**Lower Extremity Prosthetics in Bosnia –
Student cohort of 27 students/13 workshops**

Practical Examinations	Av. Student score - Entry	Av. Student score - Exit
Transtibial section	66.8	72.1
Transfemoral section	68.2	Available March, 2004
Written Examinations	Av. Student score - Entry	Av. Student score - Exit
Transtibial section	44.1	71.4
Transfemoral section	66.7	Available March, 2004

NEW CLASS

**Lower Extremity Prosthetics in Latin America –
Student cohort of 22 students/11 workshops**

Practical Examinations	Av. Student score - Entry	Av. Student score - Exit
Transtibial section	46.0	N/A
Transfemoral section	N/A	N/A
Written Examinations	Av. Student score - Entry	Av. Student score - Exit
Transtibial section	32.0	N/A
Transfemoral section	N/A	N/A

ORIGINAL LATIN AMERICAN PILOT GROUP
**Upper Extremity Prosthetics in Latin America –
Student cohort of 22 students/11 workshops**

Practical Examinations	Av. Student score - Entry	Av. Student score - Exit
Transradial section	55.8	73.9
Transhumeral section	Due end of October '03	Due end of Feb. '04
Written Examinations	Av. Student score - Entry	Av. Student score - Exit

Transradial section	57.5	85.9
Transhumeral section	Due end of October '03	Due end of Feb. '04

CIR creates monthly reports on usage of the CIR Network. The following are aggregate data for the period from May 2002 to Mid September 2003.

Successful requests for pages	88,200
Avg. successful requests for pages per day	174
Data transferred	17.3 gigabytes
Average data transferred per day	35 megabytes
Distinct hosts served	38,450

All the following statistics are for 2003 only (up to late-September). Of those total requests, around 26% come from domains that are outside the United States. The countries with the largest numbers of requests outside the United States are listed in the table below.

Domain (Country)	Percentage of Traffic
.mx (Mexico)	3.7%
.jp (Japan)	2.7%
.ar (Argentina)	2.0%
.hn (Honduras)	1.6%
.co (Colombia)	1.4%

Search engines account for nearly sixteen per cent of overall traffic. The top five domains are listed below.

Domain (Organization)	Percentage
inktomisearch.com	9.47
googlebot.com	6.90%
aol.com	2.00%
attbi.com	1.65%
covad.net	0.48

Costs

It is the goal of the IRN project to identify cost-effective strategies for the collection of rehabilitation data and the dissemination of education, training and other rehabilitation services. The IRN research project has been designed to minimize costs through a number of strategies, which include the following:

1. The use of off-the-shelf software and tools that require minimal adaptation or customization for purposes of project activities
2. The use of distance learning and other electronic dissemination strategies that minimize logistical requirements for regional activities (such as field staff, offices, and related expenses)

As the CIR continues its research activities under the IRN project, it continues to carefully collect and analyze cost data in order to refine its cost models and gauge the cost-effectiveness of the project. In the previous reporting cycle, the CIR reported on cost data relative to its initial pilot project in Latin America. In this reporting cycle, the CIR is able to incorporate additional cost data collected from its activities in the Balkans.

Using data from these two regions, the CIR has developed a Distance Learning Cost Model. The purpose of this model is to forecast the incremental costs of adding students and regions to the IRN project, and in so doing determine the cost-effectiveness of the project. The model can also assist with the identification of major project cost drivers so that project staff can develop cost saving initiatives and forecast economies of scale. The model includes both one-time, start-up costs and annual operating costs.

From this model, the CIR estimates that it costs about \$160,000 to initiate IRN activities in a given region. These one-time, start-up costs include the purchase of equipment, the adaptation of training material, and costs associated with evaluating the region and developing partnerships with regional clinics and centers. With regard to annual operating costs, the CIR estimates that 100 technicians per region per year can be trained at a direct program cost (not including overhead and content development costs) of about \$2,000, or about \$2.50 per student-hour of training. Based on current cost data, the CIR estimates that the bulk of economies of scale are derived at student populations of 100 per region.

The CIR is currently assessing strategies for cost-sharing strategies for user groups benefiting from the IRN project, such as asking network members to sharing in the costs associated with Internet connectivity and equipment. The CIR is also identifying alternative implementation strategies, such as working with regional partners like CNR in Mexico, to further reduce program implementation costs. These findings will be communicated to the Department of Defense in subsequent reports.

SOW #3: The CIR will begin offering store-and-forward teleconsultation services capable of secure communications in the areas of prosthetics, orthotics and physical medicine and rehabilitation, linking centers serving land mine survivors to clinical experts. The CIR will integrate database and teleconsultation functions into its web portal.

Project Update

The selection process for the final CIRN version of the teleconsultation services software program will identify a customizable issue tracking system offering database integration and affording secure dynamic communications between consultants and those technicians or health care workers receiving consultation in the field.

The CIR expects a teleconsultation system to be functional for testing in the second half of 2004. Since last year's annual report to the DOD there have been several developments important to developing a strategic and integrated approach. The first was

the American Telemedicine Association conference meeting, *Healthcare Solutions Through Telemedicine*, held in Orlando, Florida on April 27 through April 30, 2003 which focused on efforts and challenges specific to the Latin American region and where conference participants were brought up to date on strategic plans developed in underserved areas of the Region. The second important development from the perspective of CIR's approach was an on site visit to review the capabilities of the B-MIST system currently in use with the DOD and to explore the extension of that system to incorporate teleconsultation functionality relating specifically to the benefit of landmine victims and for related health care providers. Acquisition of the B-MIST users manual and discussions regarding access and integration of B-MIST with the CIR network are ongoing. The next step in development relates to coordination with existing teleconsultation/telemedicine systems currently in use and in development within the Latin American region. CIR has partnered with PAHO to propose a second regional conference meeting of experts in Nicaragua to take place in the Spring of 2004. The focus of this conference is on reaching people's needs by building partnerships in technology and integrates rehabilitation. Working group sessions of that conference will include focus on details for integration of efforts and an introduction to the current status of the Latin American Telemedicine Network.

Several experts in the medical field have offered to volunteer clinical consultation service time for the teleconsultation service within the CIR Network. Five clinicians in Columbia have offered to serve as consultants in coordination with the Pan American Health Organization (PAHO).

SOW #4:

a) The CIR will analyze data collected and generate a report on prosthetic outcomes that may be used to assess the effectiveness of orthopedic programs for land mine survivors. The CIR will use this information in future assessments of its programs and in the design of models of sustainable service delivery for conflict-affected regions.

Background

Providing rehabilitation services to landmine victims and other amputees in developing countries presents a great challenge to medical and rehabilitation institutes. Medical treatment and rehabilitation services are highly limited or even nonexistent in some regions. Assisting patients to achieve the greatest possible level of functional independence is the goal of rehabilitation, which includes both prosthetic and orthotic services. This goal, when achieved, reduces the overall disability level of each patient treated, and assists the person with a disability to more successfully reintegrate into society at large. Promptly identifying and replicating technologies and strategies that most effectively meet this goal is of immense importance. Less successful approaches and strategies must also be identified and curbed in order to prohibit them from utilizing the highly needed resources available in underdeveloped countries.

In support of this project, the CIR, under its Rehabilitation Engineering Research Center on Improved Technology for Landmine Survivors (RERC), has developed and refined a set of prosthetic outcome measures to be used in assessing whether the rehabilitation programs for land mine survivors are accomplishing their goals. Outcomes measures are tools used to evaluate specific aspects of the health care process, including a person's activity or functional level, their life satisfaction and health status. A limitation of other instruments is their ordinal nature, which reduces the opportunity for parametric statistical comparisons and limits the utility of the scales. While some of the outcome measures in existence have been used to evaluate functional improvement during rehabilitation, to date none others address the specialized and complex combination of functional, psychosocial and medical challenges encountered by individuals with landmine related injuries. The newly developed CIR Outcomes Measurement tool eliminates these problems.

The purpose of this IRN project is to develop a secure on-line data collection system, train service providers working in low income countries to utilize the outcomes measures instruments in the field to determine the effectiveness of their prosthetic services and to make adjustments accordingly in order to provide the best possible level of service to landmine victims and other amputees. Additionally, the outcome measures will be used to assess the impact of CIR programs, including its education and training programs, on the quality of services provided by network members. Furthermore, the CIR will utilize these lower extremity outcome measures during the field evaluations of the technologies developed under the RERC program.

Project Update

Instrument Development

The CIR's Rehabilitation Engineering and Research Center (RERC) on improved technology access for landmine survivors, in collaboration with the Rehabilitation Institute of Chicago (RIC), developed a set of outcome measures that may be used by service providers working in low-income countries to adequately assess whether the rehabilitation programs for landmine survivors are, in fact, accomplishing their goals. Uniform measures have been identified that are relevant to the rehabilitation of adults in different settings and include: 1) patient characteristics and degree of impairment; 2) functional and health status data that can be used to monitor improvement subsequent to treatment; 3) descriptions of the treatment and devices provided that can be used to evaluate the quality of these services; and 4) information relating to social reintegration (used to plan for follow-up care and programs that enhance quality of life). Interval-level measures of impairment, disability, community integration, life satisfaction, health status, employability and prosthetic equipment quality and durability, were calibrated using a technique called Rasch measurement (Rasch, 1960; Wright & Stone, 1979; Wright & Masters, 1982).

The predictors consist of patient demographic characteristics, including type and severity of injury and status at admission to rehabilitation, in terms of impairment and disability. The outcomes being examined consist of the following:

- 1) Change in impairment;
- 2) Change in independence,
- 3) Change in community integration,
- 4) Change in life satisfaction,
- 5) Change in health status, and
- 6) Change in employability.

A similar analysis is being conducted to identify the characteristics of prosthetic equipment that result in the best outcomes in terms of greater durability.

Instrument Refinement

Utilizing funding from the National Institute of Disability and Rehabilitation Research, the CIR and the Rehabilitation Institute of Chicago (RIC), in collaboration with Network members at the Telethon Foundation Pro-Rehabilitation (FUNTER) and the Armed Forces Rehabilitation Center (CERPROFA) in El Salvador, recently conducted field trials of the instruments to test their validity and reliability. The field trials utilized a 20-item lower extremity functional assessment tool, a 23-item quality of life survey, and a 21-item patient satisfaction questionnaire to rate the patient's functional status and the durability of their prosthetic or other equipment. CIR conducted training workshops prior to commencement of the study to assure that the research coordinators at the participating clinics had a full understanding of the research protocol and remote entry of the patient data into the database.

An Outcomes Database was established for this pilot study to electronically upload and store all patient responses to the questionnaires. The CIR established an integrated, secure, web-based platform that facilitates the data collection, storage and reporting, and communication among a number of clinics and hospitals in the CIRN. An integrated login framework has been established that strictly limits user access. Confidentiality of the clinical data is assured during transmission by strong encryption (128-bit SSL) and database security is assured by an industry-standard firewall.

To date (October 2003), data from 100 patients have been collected and entered into the CIR Outcomes database, and are currently undergoing analysis for validation and refinement of the instruments prior to anticipated dissemination efforts and future utilization of the instruments. This data analysis and refinement are expected to be completed by mid-November 2003.

Utilization of Instruments

Upon completion of the data analysis, the CIR plans to utilize the refined Outcomes Instruments to assess the impact of rehabilitation services at participating centers as well as the impact of CIR's Distance Learning program in lower extremity prosthetics on the

quality of those services. Additionally, the instruments will be used to assess the lower extremity prosthetic technologies developed under the RERC during the field trial phases of these projects. To date (October 2003) the protocol for the utilization of the outcomes instruments has been developed and is currently being submitted for Institutional Review Board (IRB) and Human Subjects Research Review Board (HSRRB) approval. The CIR expects to begin utilization of the outcomes instruments for the assessment of its education program in January 2004.

The purpose of this study is to assess the effectiveness of CIR's distance learning program in prosthetics and orthotics (P&O) for landmine survivors and other amputees by utilizing the outcomes measures questionnaires developed and refined during the pilot study. This information will be utilized in ongoing assessment of IRN programs and in the design of models of sustainable service delivery for conflict and post-conflict affected areas. The primary objectives of this project are to:

1. Study the efficacy of the IRN Distance Learning Program for Lower Extremity Prosthetics;
2. Monitor the level of satisfaction, functionality, and quality of the prosthetics/orthotics the patients receive;
3. Identify sociodemographic variables that might influence patients' response to care.

The CIR will conduct this research with the assistance of its Network service providers in Latin America and Eastern Europe. Training workshops will be held to demonstrate the data collection and electronic entry into the CIR Outcomes database for all participating clinics in the Network. All Outcomes Questionnaires will be completed while the participants are at their regularly scheduled appointments for the provision of a new prosthesis. Participants will be asked to provide Informed Consent, complete the CIR Outcomes Questionnaire that describes quality of life, participation in society and satisfaction with quality of equipment and services received (this will be considered baseline data for this patient.). They will complete the questionnaire again at each subsequent visit (30 days, 3 to 6 months) to compare with the baseline data and measure progress and satisfaction with the prosthetic device, and return to the participating Center 3-6 months following the last fitting for prosthesis for a one hour interview; in which additional information will be collected on equipment and services received.

The data collected in this study will be used to measure the overall level of patient satisfaction with treatment and prosthetic device at rehabilitation centers participating in the Network. By collecting data before, during and after the prosthetists at the center have completed the CIR distance education course in lower extremity prosthetics, the outcomes data can be used to assess the efficacy of the distance-learning program. Further, by collecting sociodemographic data, we plan to determine how and to what extent sociodemographic variables affect patient outcomes.

To identify the characteristics of patients who achieve the best outcomes, multiple linear regression will be used. The predictors will consist of patient demographic characteristics, including type and severity of injury and status at admission to

rehabilitation, in terms of impairment and disability. The outcomes to be examined consist of: change in impairment, change in independence, amount of community integration, change in life satisfaction, change in health status, and change in employability. A similar analysis will be conducted to identify the characteristics of prosthetic equipment that result in the best outcomes in terms of greater durability.

Data gathered from the questionnaires will be entered into the Outcomes Database for analysis by Center for International Rehabilitation staff in Chicago. Analysis will consist of comparing baseline and follow-up questionnaire responses to measure the level of improvement and satisfaction of each patient, if any, before and after prosthetic treatments. The data will be analyzed using statistical and linear regression analysis to determine degree of change.

b) The CIR will develop a survey instrument and database to house information on the status of land mine survivors and other people with disabilities internationally. The CIR will design and field test the survey instrument, develop the research activities and methodology, and collect data on a regional basis. The research methodology will include linking regional research coordinators and organizations via an electronic network integrated with the CIR web portal.

The CIR has created a research network to collect and report data on the progress, problems, and barriers experienced by landmine survivors and other persons with disabilities. The project consists of a regional data collection and a reporting model consisting of multimedia training, local data collection, and remote (electronic) data entry into a centralized database and reporting platform. In addition, qualitative and quantitative indicators of the condition of people with disabilities, including those pertaining to health services, employment, infrastructure and legal protection, have been identified on a country-by-country basis in Latin America (comprised of El Salvador, Nicaragua, Bolivia, Argentina, Belize, Chile, Columbia, Costa Rica, Ecuador, Guatemala, Honduras, Jamaica, Panama, Paraguay, Peru, Dominican Republic, Uruguay, Mexico, Surinam, Guyana, Venezuela, and Brazil).

Project Update

Research activities since October 2002 have included development and field-testing of the Research Guide, training local researchers, the development of a central database and web platform, collection and analysis of data, and the publication of an initial Compendium report.

Research Guide

The Research Guide is a survey instrument developed by the CIR and refined by an international team of experts on disability. The guide directs researchers to gather data on:

- 1) the national and regional framework of disability law and its elements including anti-discrimination clauses and equal opportunity legislation;
- 2) the social inclusion of people with disabilities as evidenced by the accessibility of communication, transportation, education, employment and other social sectors;
- 3) the disability services, activities and organizations available in the country.

The research methodology in the Research Guide consciously combines a quantitative approach, eliciting data that is comparable across countries, and a qualitative approach to obtain textured responses that will support a narrative explication. The questions are designed to draw standardized reporting from a large number of researchers, with the understanding that researchers will not be limited to questions included in the guide but rather are encouraged to document additional situations and circumstances peculiar to their locale. A copy of the revised Research Guide can be found in Appendix E.

The initial Research Guide was completed in January 2003. From January to March 2003, the guide was field tested by researchers in El Salvador and Nicaragua, who used it to collect data in their respective countries and provided feedback to the CIR. Based on the findings of this field test, the CIR refined the Research Guide and prepared it for broader dissemination through researcher training programs (further details provided below).

Training of Researchers

In the past grant year, the CIR has trained 34 researchers from 27 countries in the use of the Research Guide and methods for gathering data, conducting interviews and recruiting panel members. The training has employed a blended learning format using in-person training workshops and Internet-based distance learning methodologies.

Researchers from these two regions (the Americas and Asia Pacific) have gathered for two major regional training workshops (for materials relevant to these training sessions see Appendix E). The first of these workshops took place in Quito, Ecuador in April 2003 and the second workshop took place in June of 2003 in New York.

Training is a critical piece of the project, and covers the development of research skills as well as the research methodology itself. Researchers were trained in three primary areas, including (1) how to gather documentary evidence, including laws and legal documents pertaining to disabilities, and social inclusion policies in employment, education, health services, transportation, and housing; (2) how to conduct interviews with government officials who are responsible for enforcing disability statutes; and (3) how to arrange and conduct panel sessions to gather attitudinal or opinion data from a cross section of members of the disability community.

In addition to the in-person training, the CIR investigated the use of Internet-based training to introduce research materials and assess researcher skills and aptitude. Online discussions were moderated by the Regional Coordinators and by CIR staff, who noted

difficulties, answered questions and encouraged researcher collaboration and communication.

The web platform and CIR's distance learning capabilities will be leveraged for the continued training of researchers in the network. Effective training methodologies identified in this blended training format will be applied to other training and reporting activities in the International Rehabilitation Network project, and visa versa.

Platform Development and Central Database

The CIR has created a central database, accessed through the CIR web platform, which stores the information gathered via the Research Guide. Over the course of the project, data from the researchers is entered via web-mounted forms or store and forward technology into the database. After the data has been fact-checked, it becomes part of a publicly accessible, fully searchable knowledge bank available to advocates and researchers around the world via the CIR website. The CIR will also submit the main dataset to the Inter-University Consortium of Political and Social Research (ICPSR) at the University of Michigan in order to increase its availability for scholarly research.

In partnership with private software developer Control Room Technologies, the CIR has implemented a number of functionalities to its web portal to facilitate the input and transfer of data to the central database. These include the creation of an online registration and login system for researchers and online data entry forms and secure data input functionality. Sample screen shots are provided in Appendix E.

KEY RESEARCH ACCOMPLISHMENTS

- Developed the multimedia Ischial Containment Module Set
 - HTML versioning
 - Graphics
- Developed the content for Transhumeral Module-set
 - HTML versioning
 - Graphics
 - Translation into Spanish
- Refined and adapted Module-set for CIR Transtibial Socket Fabrication System
 - HTML versioning
 - Graphics
- Conducted Training in Ischial Containment
 - Organized a five day clinical and evaluation workshop in El Salvador
- Transfer of technology via internet on CIR Transtibial Socket Fabrication to the Vietnamese Technology Center for Orthopedic Technologists (VIETCOT)
- Update Rehabilitation Resource Directory
- Added five new rehabilitation centers, 22 students, and one new country (Honduras)
- Currently training 75 students
- Partnership with Mexican National Rehabilitation Center (NRC) was formalized
- Developed a three-year curriculum for a degree in prosthetics and orthotics
- Developed an agreement with the Gradina Prosthetic Center in Tuzla, Bosnia
- Invited to participate in the World Health Organization's (WHO) Guidelines for Training Personnel in Developing Countries at the University of Strathclyde in Glasgow, Scotland
- IDRMM initiated a research network to collect and report data on the progress, problems, and barriers experienced by landmine survivors and other persons with disabilities.
- Development and field-testing of the Research Guide
- Training local researchers, the development of a central database and web platform, collection and analysis of data
- Publication of an initial Compendium report.
- The CIR attended and presented its Lower Extremity Distance Learning Program at the "ISPO Workshop on Prosthetics and Orthotics Training Institutes in Non-industrial Countries" held February 26 to March 2, 2002 in El Salvador.

REPORTABLE OUTCOMES

- Participation of 28 Centers in the Distance Learning Program
- 75 students currently enrolled in Distance Learning educational courses
- Development of 20 new training modules in 3 module sets
- 3 module sets completed by students in Year 3 (Transradial, Transfemoral, Transtibial)
- Establishment of an MOU with the National Rehabilitation Center (CNR) in Mexico

DOD Annual Report for Award # DAMD17-00-1-0711

- 118 patients participated in research
- Participated in 5 P&O Conferences
- CIR staff organized and held 4 conferences related to disability rights research
- Completed and widely distributed the Disability Rights Compendium
- 72 hours of workshops for supervised clinical training for students
- 384 hours of unsupervised hands-on clinical work
- 483 hours of asynchronous didactic training
- 63 hours of synchronous training (9 on-line conferences and 33 Case Presentations)

CONCLUSIONS

In the third year of the IRN research project, the CIR successfully expanded its Internet-based prosthetic education program in terms of the web platform, learning content and geographic reach.

Findings from the first two years of the IRN project indicated the potential of the CIR's web-based platform to deliver training and electronic services to remote locations. In the third year, steps were taken to expand the functionality of the web platform. Through a partnership with a private software developer, the functionality of the online directories, online forums, data entry and reporting sites and distance learning sites was enhanced.

In the reporting period, 21 new modules were created for 3 new module sets, including Ischial Containment, the CIR Casting System for Transtibial Prosthetic Socket, and the Transhumeral Module Set. Modules were adapted for use in Latin America and the Balkan region. In addition, the CIR developed an innovative partnership with the National Rehabilitation Center in Mexico City (CNR) to develop additional training content in the area of orthotics. This international educational collaboration presents an exciting new opportunity for this distance learning project. Findings of IRN research in the use of telecommunications for training received international attention at conferences such as the WHO-sponsored "Guidelines for Training of Personnel in Developing Countries", held in Glasgow Scotland earlier this year.

Finally, in the third year the CIR successfully expanded the IRN research program to the Balkans. In the reporting period, the IRN project delivered Internet-based training content to 11 rehabilitation centers in Central America and 13 centers in Bosnia-Herzegovina and Slovenia, which together treat thousands of prosthetic/orthotic patients each year, many of whom were injured as a result of regional conflicts. The IRN program also significantly expanded its network of disability organizations in Latin America, training these organizations on the collection of research on the condition of landmine survivors and other people with disabilities in their countries.

The international activities of the IRN project are supported by important regional partnerships. In the reporting period, the CIR developed partnerships with CNR in Mexico, rehabilitation centers in Tanzania, Vietnam and Bosnia, and with the Ministry of Martyrs and Disabled of the Government of Afghanistan.

An evaluation of the IRN project to date suggests that the program has significant potential as a cost-effective means to effectively disseminate training and electronic services to remote, under-served locations. User evaluations suggest that students of the IRN program rate the program, its content, and their trainers highly, which is also supported by the program's significant retention rate. Cost analysis suggests potential for economies of scale with regard to project scope.

CENTER FOR INTERNATIONAL REHABILITATION
Annual Report to the Department of Defense
#DAMD17-00-1-0711

APPENDIX A

CIR/CNR Action Plan
CIR/CNR MOU
Special Topics Proposal
Lower Extremity Orthotics course outline
IRN Advisory Council Members
Scope of Work for IRN Advisory Council
Executive Summary of IRN Education Panel Meeting

PERFORMANCE ATTACHMENT No. 1 "PLAN OF ACTION" TO DEVELOP LONG-DISTANCE LEARNING PROGRAMS IN PROSTHETICS, ORTHOTICS, AND PHYSICAL REHABILITATION, SIGNED BY THE NATIONAL REHABILITATION CENTER, HEREINAFTER CNR, REPRESENTED BY ITS DIRECTOR GENERAL, DR. LUIS GUILLERMO IBARRA; AND BY THE CENTER FOR INTERNATIONAL REHABILITATION, HEREINAFTER CIR, REPRESENTED BY ITS PRESIDENT, WILLIAM KENNEDY SMITH M.D., PURSUANT TO THE FOLLOWING CLAUSES AND:

RECITALS

On the 30th day of the month of June, 2003, CNR and CIR signed the Memorandum of Understanding to establish long-distance education programs on prosthetics, orthotics, and physical rehabilitation, which for purposes of this legal instrument shall be referred to as the MOU.

The parties acknowledge the legal capacity they claim to have, in conformity with the representations made in the aforementioned MOU.

For purposes of the present instrument, their respective addresses shall be those set forth in the representations of the aforementioned legal instrument.

The objectives of the MOU include that of drafting performance attachments to develop the long-distance education programs.

In view of this, the parties hereby agree to observe the terms and conditions set forth in the following:

CLAUSES

FIRST. OBJECTIVE

The objective of this Performance Attachment No. 1 "Plan of Action" is the development of the plan of action in which to establish the bases for collaboration between CNR and CIR to carry out the necessary long-distance education programs on prosthetics, orthotics, and physical rehabilitation, thereby ensuring full equality of opportunity for people with disabilities in Mexico and, if applicable, transferring the results of this "Plan of Action" to Central America, for the fulfillment of the objectives established in the MOU.

SECOND. UNDERTAKINGS BY BOTH PARTIES

The parties agree that during the development of the present legal instrument they shall:

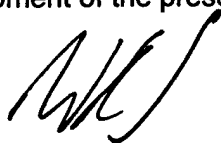

a) Identify the specific educational content to be developed through a working plan that shall include the following topics:

Help Desk and Instruction on WebCT Courseware (on the understanding that WebCT is the software program used for the creation and administration of long-distance learning courses).

- a. Lower Extremity Orthotics.
- b. Upper Extremity Orthotics.
- c. Spinal Orthotics.

The execution of each topic will contain text, graphics and multimedia features, as outlined by CIR's description in its Editorial Guidelines, which for these purposes it provides to CNR in the timelines set forth in section C of this clause.

b) Establish a process for the joint development of such educational content.

c) Develop the educational content

Once the educational content to be developed is established, it shall be executed according to the following working plan:

- 1. The time periods mentioned in this performance attachment shall be counted in calendar days, weeks, or months, as of the signing date of this document.
- 2. Upon signing this performance attachment, CIR shall provide CNR with the following:
 - 2.a) Editorial guidelines regarding the format of the educational content to be developed;
 - 2.b) Transtibial (hereinafter TT) online program description and syllabus;
 - 2.c) Storyboards of the TT and Transfemoral module sets;
 - 2.d) Sample case presentations and online conferences, and
 - 2.e) TT video clips.

CIR staff will review these items with CNR staff to ensure their understanding.

- 3. Upon the conclusion of the following two weeks, CIR shall make the necessary equipment available to CNR to facilitate the preparation of prosthetic and orthotic training materials suitable for electronic installation and distribution, as well as multimedia formats. The description of the equipment mentioned in this clause shall form part of this agreement as Attachment 1.

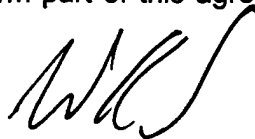

CIR will continue to make this equipment available to CNR for the duration of this Attachment and the subsequent Performance Attachments signed by the parties during the effective period of the MOU. By signing below, the Parties acknowledge that this equipment remains the property of the CIR unless otherwise authorized by the CIR. CIR reserves the right to recall this equipment should either party terminate this Attachment or the MOU. Should CIR recall the equipment, the packaging and shipping expenses shall be borne by CIR, and shall not exceed \$15,000, inclusive of other transport and shipping expenses as detailed in the fifth clause hereof.

4. Upon the conclusion of the first month, CNR shall provide CIR with a draft outline of the Lower Extremity Orthotic module set, which shall include a list of modules to be covered, as well as the approximate number of graphs, images and video clips to be incorporated into the educational content.
5. Six weeks after the draft has been delivered, CIR shall review the observations made by CNR on the aforementioned draft. This evaluation shall be performed within a period of two weeks.
6. Two months after the delivery of the draft, CNR shall install in the server the Help Desk and WebCT instructional use modules.
7. CNR shall provide students enrolled on the Lower Extremity Prosthetics course with the necessary information and technical support.
8. Once three months shall have passed after the delivery of the draft, CNR will make available to CIR the first five modules of the Lower Extremity Orthotic module set, including:
 - 8.a) A minimum of ten questions per module
 - 8.b) Glossary and
 - 8.c) The objectives and conclusions of each module.
9. Two weeks after the period mentioned in the previous section, CIR shall provide feedback to the CNR with its observations and comments.
10. Four and a half months after the delivery of the project, CNR submit the second and final set of modules for approval and review by CIR. This second submission shall include:
 - 10.a) All questions,
 - 10.b) Glossary, program description
 - 10.c) Syllabus to be used for in the online broadcasting.
11. At the end of five months after the delivery of the draft, CIR shall review and provide feedback to the CNR project manager for the performance attachment "Plan of Action".
12. The parties agree that, in accordance with the process and timing outlined above, the parties shall complete the development of the educational content



by the following schedule, counted from the signing date of this legal instrument:

- 12.a) Second month: Help Desk and Instruction on WebCT Courseware.
- 12.b) Fourth month and two weeks: Complete Lower Extremity Orthotics course.
- 12.c) Seventh month: Complete Upper Extremity Orthotics course.
- 12.d) Tenth month: Complete Spinal Orthotics course.

d) Develop and implement a joint method for the delivery of prosthetic and orthotics training and education according to the following working plan:

1. From August 1, 2003: a previously designated CNR representative shall provide online teaching and support for the Lower Extremity Prosthetics Long-Distance Learning Program in Central America. For its part, CIR shall provide training and guidance to CNR staff about their expectations and technical issues regarding the courses and teaching procedures.
2. From August 4 through 15, 2003: A previously designated CNR faculty member shall assist CIR staff to organize and conduct the initial practical and theoretical evaluation of the students enrolled in the following courses: Lower Extremity Prosthetics course, Transtibial course; in Nicaragua and El Salvador.
3. From December 1 through 12, 2003: A previously designated CNR faculty member shall assist the CIR staff to organize and conduct the final practical and theoretical evaluation of the students participating in the Lower Extremity Prosthetics course, Transtibial course, and the entry evaluation of the Transfemoral course.
4. Representatives of the CNR faculty shall assist the CIR staff to organize and conduct the final practical and theoretical evaluation of the students enrolled in the Transfemoral Lower Extremity Prosthetics course. A date shall be set by both parties.

The CIR representatives in the Central American region shall assist the CNR staff with the coordination and implementation of said courses, the evaluations of which shall be held in Managua, Nicaragua and San Salvador, El Salvador. The parties agree that all the necessary transportation and traveling expenses shall be paid for by CIR. The expenses shall not exceed US\$15,000, including other transportation expenses, as mentioned in the fifth clause hereof.

THIRD. VALIDITY

This "Plan of Action" Performance Attachment will be effective for 12 months as of its signing date.



FOURTH. HEAD OF STAFF

Each party will appoint a member of staff responsible for acting as its representative regarding the implementation and management of this Plan of Action.

On behalf of CNR:

Dr. Alberto Odor, Head of the Orthopedic Investigation Division, who designates the following address for purposes of this legal document: Av. México-Xochimilco, No.289, Col. Arenal de Guadalupe, Deleg. Tlalpan, Tel. (5255) 5999-0950, E-mail: aodor@cnr.gob.mx.

On behalf of CIR:

Héctor Casanova, who designates the following address for purposes of this legal document: 351 E., Huron, 2nd Floor Annex, Chicago, Illinois, Tel. (312) 926-0018, E-mail: h-casanova@nwu.edu.

The parties agree they may change their head of staff and liaison officer at any time by giving prior written notice to the other party.

FIFTH. PROGRAM SPONSORSHIP

The budget assigned to this Performance Attachment is US\$74,952.00 (SEVENTY-FOUR THOUSAND NINE-HUNDRED FIFTY-TWO US DOLLARS). The sum of US\$27,597.00 (TWENTY-SEVEN THOUSAND FIVE-HUNDRED NINETY-SEVEN US DOLLARS) will be used for the purchase of equipment by CIR. The sum of US\$15,000.00 (FIFTEEN THOUSAND US DOLLARS) will be allocated to expenses for transportation and travel and includes: consolidation and shipping expenses, customs, expenses for shipping equipment and journeys to Central America by CNR staff. CIR shall reimburse CNR US\$32,355.00 (THIRTY-TWO THOUSAND THREE-HUNDRED FIFTY-FIVE US DOLLARS) as compensation for assigning CNR to implement of this Performance Attachment No. 1 "Plan of Action". Payment will be made in 4 installments of US\$8,088.75 (EIGHT THOUSAND EIGHTY-EIGHT US DOLLARS AND SEVENTY-FIVE CENTS) each, in observance of the following items:

- Installment 1: Two weeks counted as of the signing date hereof as an advance for costs associated with the completion of the Help Desk and WebCT Instruction Module Set.
- Installment 2: Upon completion of the Lower Extremity Orthotics Module Set (four months).
- Installment 3: Upon completion of the ~~Upper~~ Extremity Orthotics Module Set (seven months).
- Installment 4: Upon completion of the Spinal Orthotics Module Set (ten months).

These amounts shall be submitted to the CNR liaison officer in charge mentioned in the Fourth Clause, who will provide CIR with receipts for personal fees issued by those benefited in order to justify the expenses.



SIXTH. INTELLECTUAL PROPERTY

The parties agree that CIR will own all intellectual property rights, including copyrights, in and to any and all programs, materials, products, content, technology, or other works developed in connection with the activities contemplated in this legal instrument. Such ownership will be on a worldwide basis, without limitation.

However, the parties agree that the content developed in connection with this performance attachment is available for use by CNR for the instruction of students enrolled on CNR's own educational courses under a royalty-free license from CIR. This license is non-exclusive and does not include the right of CNR to sublicense or transfer the content to other parties or the right to assign its own license to other parties, without the express written consent of CIR. Use and presentation of the long-distance learning content will be required to conform to specifications determined by CIR (including acknowledgement of CIR and the display of the CIR logo and graphic identity).

SEVENTH. MODIFICATIONS AND EARLY TERMINATION

The parties agree that any modification or addition shall be formalized in writing by both parties and will enter in force on its signing date.

EIGHTH. CONFIDENTIALITY

All printed, verbal, audiovisual or other kind of information that may be considered a document, resulting from the development of this Performance Attachment shall be confidential; such information shall only be published or released with the prior written consent of the other party.

NINTH: JURISDICTION

The parties agree that the present instrument is the result of good faith; hence any interpretation and controversies derived from its operation, formalization, or fulfillment shall be resolved by mutual agreement and the parties only agree to submit to the jurisdiction of the internal legislation of the State of Illinois, United States of America, in the event of continued controversy.

The parties agree that the present performance attachment is an integral part of the MOU signed on the 30th day of the month of June, 2003, and that the commitments established in said document shall remain valid and in full legal force.



The parties, having read this instrument and being informed of its content and scope, signed it witness thereof, in the city of Chicago, Illinois on the 30th day of the month of June, 2003, on four counterparts, two in English and two in Spanish, each party keeping one counterpart in English and one in Spanish.

SIGNATURES

BY "CNR"

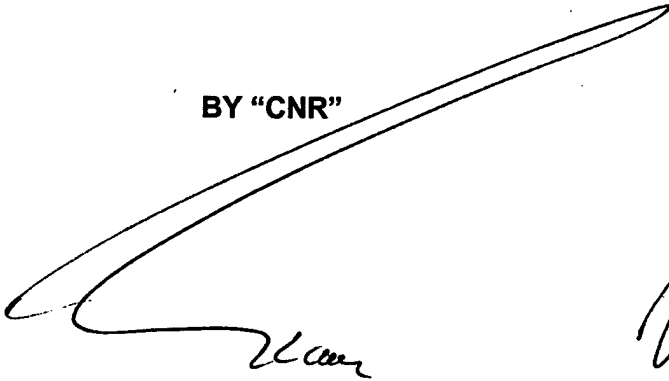
A large, stylized handwritten signature in black ink, consisting of a long, sweeping horizontal line that curves upwards at the end, with a smaller, more detailed signature below it.

DR. LUIS GUILLERMO IBARRA
DIRECTOR GENERAL

BY "CIR"

A handwritten signature in black ink, appearing to be 'WKS' followed by a stylized 'Smith'.

DR. WILLIAM KENNEDY SMITH, M.D.
PRESIDENT

The preceding signatures correspond to the Performance Attachment "Plan of Action" signed by the National Rehabilitation Center and the Center for International Rehabilitation on June 30, 2003.

MEMORANDUM OF UNDERSTANDING (HEREINAFTER REFERRED TO AS MOU) TO SET UP LONG-DISTANCE EDUCATION ON PROSTHETICS, ORTHOTICS, AND PHYSICAL REHABILITATION, ENTERED INTO BETWEEN THE SECRETARIAT OF HEALTH THROUGH ITS NATIONAL REHABILITATION CENTER (HEREINAFTER REFERRED TO AS CNR) REPRESENTED HEREUNDER BY ITS DIRECTOR GENERAL, DR. LUIS GUILLERMO IBARRA, AND THE CENTER FOR INTERNATIONAL REHABILITATION (HEREINAFTER REFERRED TO AS CIR), REPRESENTED HEREUNDER BY ITS PRESIDENT, WILLIAM KENNEDY SMITH M.D., PURSUANT TO THE FOLLOWING REPRESENTATIONS AND CLAUSES:

REPRESENTATIONS

I BY CNR

I.1 In accordance with Article 2, Literal C, subsection VI, 34 and 40, subsections I and XVI of the Secretariat of Health's Internal Regulations, published in the Official Gazette of Mexico on July 5th, 2001; the National Rehabilitation Center is a de-concentrated administrative entity of the Secretariat of Health, hierarchically subordinated and with operational autonomy. Its functions include providing high-level specialist medical services, as well as contributing to the operation and functioning of establishments that provide prevention and rehabilitation services for people with disabilities, in coordination with the proper administrative units.

I.2 In accordance with Article 40, subsections II, V and X of the Secretariat of Health's Internal Regulations, it is in charge of drafting, developing, and coordinating the programs to provide specialist medical attention in its prevention, medical, rehabilitation, and if necessary, surgical aspects; carrying out clinical, experimental, technology development, and basic studies and research in biomedical and socio-medical areas in the field of specialties under its responsibility for a better development of prevention, diagnosis, and rehabilitation of disabling diseases, as well as promoting health measures; promoting and encouraging coordination, diffusion, and exchange in the matters within its area of responsibility with health and higher education institutions, both within the country and abroad.

I.3 That it is empowered to sign this Agreement, in accordance with Article 36, subsection V of the Secretariat of Health's Internal Regulations.

I.4 For purposes of this agreement, its address is Avenida México Xochimilco Número 289, Colonia Arenal de Guadalupe, Delegación Tlalpan, C.P. 14389, México, Distrito Federal.

II. BY CIR

II.1 The Center for International Rehabilitation (CIR), is a non-governmental organization established in Chicago, Illinois, United States of America, whose mission is to help people with disabilities around the world to realize their maximum potential, focusing



attention on research about their unique needs, improving services and results to raise their quality of life.

II.2 It has the facilities, first-rate equipment, and highly trained staff to carry out this agreement's objective.

II.3 William Kennedy Smith M.D., as president of the Center for International Rehabilitation, has powers to represent it and to sign this memorandum.

II.4 That it has a long-distance education association, which is in charge of developing and disseminating the collection of audiovisual material for education on prosthetics, orthotics, and rehabilitation.

II.5 For purposes of this agreement, its address is 333 East Hurón, 2nd Floor Annex, Chicago, Illinois, 60611.

III THE PARTIES REPRESENT

That it is their wish to provide long-distance education on the crafting of prosthetics, orthotics, and physical rehabilitation, thereby improving services for people with disabilities in Mexico and, subsequently, in Latin America.

Wherefore, the parties sign this MOU pursuant to the following:

C L A U S E S

FIRST.OBJECT

The object of this MOU is to establish a working framework for the parties to implement a plan of action to collaborate in the development of long-distance education programs on prosthetics, orthotics, and rehabilitation. Upon formalizing this agreement, the CNR shall become a member of the association mentioned in Representation II.4 which the CIR possesses for this purpose; with the ability to access and deliver the educational content developed by other members of the association as described in the third clause of this MOU. The foregoing, in accordance with the performance attachments that will be signed during the development and effective period of the MOU, will also be an integral part of this legal instrument.

SECOND. CNR'S OBLIGATIONS AND RESPONSIBILITIES

- a) To provide CIR with the necessary information and educational content for its distribution according to the terms detailed in this MOU.
- b) To provide the necessary and vital materials related with prosthetics, orthotics, and rehabilitation, including presentations on electronic media and the associated trial



materials to be used as content in the long-distance education under the conditions established in this MOU, as described in "Plan of Action" No. 1.

- c) To coordinate actions with CIR in the adaptation of these materials for their distribution through long-distance education methodologies.
- d) To collaborate with CIR and, if necessary, with the Pan American Health Organization, to diffuse the education on prosthetics, orthotics, and rehabilitation through long-distance education provided to students in Latin America.
- e) To create a service of instruction and technical support to prevent and solve problems encountered by students registered on the long-distance education program.

THIRD. CIR'S OBLIGATIONS AND RESPONSIBILITIES

- a) To appropriately reward CNR for the work carried out under the terms of this MOU, in accordance with the provisions of Performance Annex 1 entitled "Plan of Action" that forms an integral part of this legal instrument.
- b) To act as a collection of audiovisual material for long-distance education for the obtainment of educational material on prosthetics, orthotics and rehabilitation, so that these materials will be available to CNR for use in its educational programs under the licensing and supervision of CIR; the terms by which these programs shall be used shall be agreed upon by the parties in future Performance Attachments.
- c) To provide the staff determined by CNR with access to CIR programs and products, developed by the Center for Investigation of Rehabilitation Engineering or the long-distance education area of the CIR.
- d) Provide its expert opinion on the development of the educational content, design, and long-distance education provided through the CIR staff mechanisms and/or the Advisory Board.
- e) To incorporate CNR among the activities associated with the CIR Advisory Board, including the program's evaluation, development of the educational content and the recruitment of new members.

FOURTH. UNDERTAKINGS BY THE PARTIES

The parties will sign a Performance Attachment, in which a "Working Plan" will be developed to carry out the following actions:

- a) To identify, establish a process, and develop the educational content to be produced.



- b) To develop and implement a joint method for training in the crafting of prosthetics and orthotics.
- c) To coordinate and carry out the clinical and complimentary workshops of the long-distance education course, which is composed of theoretical and practical onsite teaching and the assessment of students.

FIFTH. HEAD OF STAFF

Each party shall appoint a designated representative who will serve as a liaison officer and will be responsible for the relationship, implementation and administration of this MOU:

For CNR:

Dr. Alberto Odor, Head of the Orthopedics Research Division; Address: Av. México-Xochimilco #289. Col. Arenal de Guadalupe, Deleg. Tlalpan. Tel: (5255) 5999-0950.

For CIR:

Héctor Casanova; Address: 351 E., Huron, 2nd Floor Annex, Chicago, Illinois. Tel. (312) 926-0018.

The parties agree they can change their head of staff and liaison officer at any time by written notice to the other party.

SIXTH: LABOR RELATIONSHIP

It is expressly stipulated that the parties sign this MOU on the understanding that each one of them has the necessary staff and elements of their own to execute the activities subject matter of this legal instrument. They therefore accept that if staff from one of the parties shall work at the facilities of the other in order to fulfill this agreement, no labor relationship shall be created with the latter party; consequently they may not be considered as substitute or joint employers, since each of the parties will assume the responsibilities that correspond to them in such relationship.

SEVENTH: CIVIL LIABILITY

It is expressly agreed that the parties shall have no civil liability for damages and lost profits that may occur as a consequence of ~~acts of God~~ or force majeure, particularly for stoppages of academic or administrative work.

EIGHTH: INTELLECTUAL PROPERTY

All intellectual property rights resulting from the activities established in this MOU will be the property of CIR. However, said property may be made available to CNR to be used under license from CIR through an agreement signed by both parties.



NINTH: CONFIDENTIALITY

Both parties agree that the documents, files, computer disks, tapes or any other electronic or physical medium considered a document shall be regarded as confidential and the exclusive property of the respective party, and shall be returned to the party that generated it upon the conclusion of this MOU. The parties agree that during the effective period of this MOU or after its early termination, any information derived from the fulfillment of this MOU will remain confidential and they will not disclose this information or allow it to be disclosed to a third party.

TENTH: VALIDITY, MODIFICATIONS, AND EARLY TERMINATION

This MOU will enter into force on the day following its signature and will be valid indefinitely. Notwithstanding the foregoing, the parties may periodically review it in order to add to it, modify it, or if necessary, adjust it to suit the needs of the parties.

In addition, it may be concluded any time at the request of either of the parties by written notice of at least 60 calendar days to the other party, in which case, the necessary measures will be taken to prevent mutual or third-party damages, and to conclude any actions that have been begun, unless otherwise stipulated.

Any modification, addition or amendment must be formalized in writing through agreements set by the parties and signed by the legal representatives, which shall form integral parts of this MOU and shall become effective on their signing date.

ELEVENTH: PUBLICATIONS

It is the will of the parties that all publications in scientific journals and magazines stemming from the joint activities developed in this legal instrument shall acknowledge those who participated in their creation.

TWELFTH: TECHNICAL ATTACHMENT

The parties agree to establish Performance Attachments that shall include the budget and the technical and administrative activities, a timeline and responsibilities for each of the parties; it will be developed jointly during the first 60 days after this MOU's signing date. After that date, the parties will agree to and implement subsequent plans of action each year.

THIRTEENTH: INTERPRETATION AND CONTROVERSIES

The parties agree that this instrument is the result of good faith; hence any interpretation and controversies derived therefrom in respect of its operation, formalization or fulfillment



will be resolved by mutual agreement. The parties agree to submit to the jurisdiction and legislation of the State of Illinois only in the event of continued controversy.

The parties, having read this instrument and being informed of its content and scope, signed it witness thereof, in the city of Chicago, Illinois on the 30th day of the month of June, 2003, on four counterparts, two in English and two in Spanish, each party keeping one counterpart in English and one in Spanish.

SIGNATURES

BY CNR

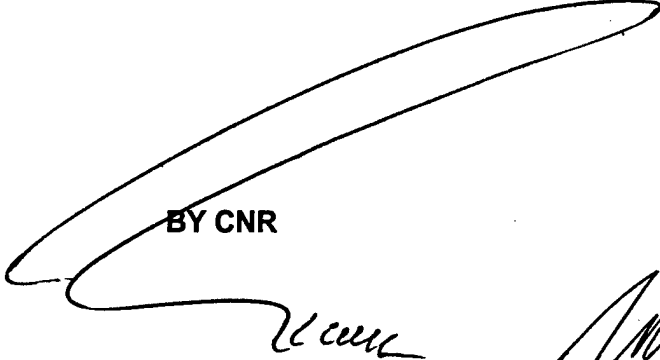

**DR. LUIS GUILLERMO IBARRA
DIRECTOR GENERAL**

BY CIR



**DR. WILLIAM KENNEDY SMITH, M.D.
PRESIDENT**

The preceding signatures correspond to the Memorandum of Understanding (MOU) signed by the Secretariat of Health through the National Rehabilitation Center (CNR) and the Center for International Rehabilitation (CIR), on June 30, 2003.

SECOND REGIONAL CONFERENCE
MEETING OF EXPERTS: REACHING PEOPLE'S NEEDS BY BUILDING
PARTNERSHIPS IN TECHNOLOGY AND INTEGRATED REHABILITATION

DATES:
Spring 2004

VENUE:
Intercontinental Managua

LOCATION:
Managua, Nicaragua

BACKGROUND:

The Center for International Rehabilitation (CIR) and The Pan American Health Organization/World Health Organization (PAHO/WHO), in partnership with the U.S. Army Medical Research and Materiel Command (USAMRAC), is planning to sponsor a second Regional Conference for a meeting of experts in the rehabilitation field. The intent of the conference is to bring expertise from public health, scientific fields, data gathering from experts, technology and tools from the various partners identified from the organizers. The conference will be used as a regional platform identifying areas of interest in the Region. The conference is intended to identify problems and provide solutions through the development of tools, core curriculum and strategic plans in order to develop outcomes, progress to effectively enable countries of the region to evaluate their progress in core themes brought out through the conference.

In preparation for this conference, CIR convened the first Regional Conference addressing issues of Rehabilitation and Technology during July 2001 with international representatives and experts from the Region. Participants of the first conference included: (a) governmental and non-governmental organizations, (b) international rehabilitation experts, (c) consumers, (d) universities and (e) disability advocates. Over 30 regional and international organizations, including the International Committee of the Red Cross (ICRC) and Handicap International attended and actively participated. During this conference discussions were held regarding the ongoing medical and rehabilitation needs of land mine survivors and those professionals serving them in the Latin American region.

PAHO and CIR have identified two priority areas for the second regional conference, including:

- (1) the need to develop core curricula for First Emergency Responder's (FERs) to respond and address public health issues, operate and provide immediate assistance to remote and affected populations, and
- (2) the need to identify how FERs are useful in addressing people's needs by targeting the most vulnerable and inaccessible populations through community-based rehabilitation strategies.

Obstacles confronted by FERs include limited access to information, communication, environment and innovative health care technologies that can be used promptly to address problems on site. It is essential to strengthen and improve both civilian and the military's FERs role to deliver appropriate humanitarian assistance to populations, especially those in remote areas where landmines and other unexploded ordinance are present. These remote populations suffer the most serious consequences during periods of crisis.

For the Second Regional Conference, the following areas will be addressed through the combined efforts of five simultaneous working groups, including:

1. Curriculum development for FERs needs;
2. Tele-consultation & Telemedicine
3. Research and Development of Rehabilitation Engineering Research Center (RERC) on Improved Technology Access for Landmine Survivors
4. Human Rights and
5. Early Screening Intervention

Purpose:

The purpose of this second regional conference is to share lessons learned from international experts and develop inter-sectorial relationships among professionals of the public safety, health care, and educational communities leading to a sustainable and integrated approach to rehabilitation.

Objectives:

- The Conference will focus on current information, data, immediate assistance, appropriate technology, integrated rehabilitation, public safety and security topics, post-crisis status of specific areas within the Region.
- Create strategy and action plans consistent with the use of innovative technology, to meet the perceived requirements for persons with disabilities and to provide information regarding operations and decision support in order to construct systematic approaches to improve management systems.
- Integrate regional action plans to be consistent with other organizational management systems, goals and policies of countries within Latin America.
- To produce the design document for curriculum covering topical areas within the FER content area, leading to the development of online FER content accessible to members of the Latin American region and beyond.

Sessions & Topics:

The workshop will be a mix of formal presentations by power point, primarily from the FER sessions, but primarily working group discussions. Details regarding session topics and objectives are provided in the following section of this proposal.

SESSION I: CURRICULUM DEVELOPMENT FIRST EMERGENCY RESPONDER (FER):

- Casualty Evacuation and Stabilization stages
- Life and Limb Saving Surgery
- Re-constructive Surgery
- Post-operative Care of Residual Limb
- Pain Management (in general) and specifically Residual Limb loss and saving operations (phantom pain/psychological considerations).
- Promoting CBR workers as FERs and assisting them in linking the 5 identified working group subjects by raising the awareness level to form an integral approach and develop effective frameworks for establishing, assessing current practices and policies that will best suit the agency/institutions needs and culture.

FER session objectives:

- Determine the most effective ways of meeting FERs, persons working to implement the Community Based Rehabilitation (CBR) Strategy and remote populations needs.
- Familiarize FERs and CBR workers with current and applicable technical uses of science, data, and technology;
- Guide FERs and CBR representatives to appropriate sources of data, software, technical support; and,
- Create a broad-based network to support and strengthen FERs and CBR workers needs.
- Address Regional issues to strengthen government's role to develop key strategic alliances and partnerships; to reach the peoples needs through the assistance of FERs and CBR.

SESSION II: TELE-CONSULTATION & TELEMEDICINE:

- Follow up of the ATA conference meeting, *Healthcare Solutions Through Telemedicine*, held in Orlando, Florida on April 27 through April 30, 2003 to bring up conference participants up to date on strategic plans developed in under served areas of the Region.
- Results and recommendations of the ATA Conference, 2003, Future steps to be taken.
- Immediate reply, providing solutions and decision support for FERs and CBR workers in remote areas. Topics addressed in the curriculum development and other areas identified as priority needs.
- Introduction to the Latin American Telemedicine Network.
- Description and benefits of Mobile Clinics in Ecuador. Presentation of the experience of the Ministry of Health, Monterey, Mexico.
- Continuing education for human resources and health professionals through PAHO's Virtual Campus Initiative; description of courses offered, benefits and collaboration with educational institutions; PAHO's collaboration with CIR's; improving human resource capacity through continuing education.
- Dialogue of programs in place to address the needs of communities in remote areas, how current technology is applied, lessons learned; and presentation of case studies of how technology has been applied.

SESSION III: Research and Development of Rehabilitation Engineering Research Center (RERC) on Improved Technology Access for Landmine Survivors

(A) Increasing Service Delivery Through Improved Fabrication Tools and Techniques

- **Socket Fabrication Methods:**
The CIR Prosthetic Casting System is a tool for prosthetists that eliminates the need for taking a plaster cast and the use of Plaster-of-Paris by using sand and vacuum to make a negative mold of the residual limb followed by a positive model. The system offers significant savings in time and expense since and is an inexpensive reusable resource.
- **Pre-Fabrication Alignment Methods:**
Prosthetic alignment, including bench, static and dynamic alignment, is a time consuming process requiring years of experience. The CIR is exploring methods of obtaining acceptable alignments by taking appropriate measurements at the time of casting, thereby allowing for the fabrication of mono-limb prosthesis that can be delivered without needing further alignment. The alignment technique coupled with monolimb fabrication can greatly facilitate service delivery to remote areas.

(B) Increasing Amputee Functionality Through Improved Prosthetic Devices

- **Prosthetic Feet:**
The prosthetic component most likely to fail in developing countries is the foot. Northwestern University Prosthetics-Orthotics Center (NUPOC) has shown that there exists a characteristic roll-over shape, for healthy individuals, that is often significantly different from the roll-over shape of prosthetic feet commonly available in developing countries. Thus, in cooperation with NUPOC a co-polymer, plastic foot, having an appropriate

roll-over shape, and suitable for the environmental conditions in most developing countries has been developed.

(C) Increasing Independence Through Improved Wheeled Mobility Appropriate for Mine-Affected Regions

- Wheelchairs:
Many wheelchairs currently available are not appropriate for the rugged terrain often found in mine-affected regions, and fail within months of being put into service. In cooperation with Whirlwind Wheelchair International, an adjustable, adult wheelchair has been developed that can withstand the rugged environmental conditions.

(D) Increasing the Quality of Products and Services Through Assessment Techniques

- Outcomes Measures:
Outcome measures assess the impact of rehabilitation services at participating centers. Services. Uniform measures have been identified that are relevant to the rehabilitation of adults and children in different settings. Information collected includes patient characteristics and degree of impairment, functional and health status data that can be used to monitor improvement subsequent to treatment, descriptions of the treatment and devices provided that can be used to evaluate the quality of these services, and information relating to social reintegration. There is a 20-item lower extremity functional assessment tool, a 23-item quality of life survey and a 21-item patient satisfaction questionnaire. This tool is an important mechanism for obtaining consumer feedback.
- Resource Directory; evaluation of benefits and user capacity

SESSION IV: Human Rights

- UN Activities, future steps to be taken for the fundamental rights and freedoms for persons with disabilities
- Regional Approaches in the Americas for Human Rights; what has been accomplished in mental health, a model for persons with disabilities; creating an integrated approach for international program development.
- Presentation of the International Disability Rights Monitor (IDRM) pilot phase developed by CIR. Current progress and potential benefits for the Region of the Americas.

SESSION V: Early Screening Intervention

- To identify instruments and strategies that permit the Early Detection of disabilities in children from 0 to 6 years, in Latin America.
- Analyze jointly with key experts instruments applied in early detection of disabilities, in Latin America.
- Create a network of experts for the exchange of information on early detection.
- Promote the development of strategies of Early Detection in developing countries.

Expected results for all sessions:

- Instruments and/or viable strategies for FERs-CBR workers in Latin America identified.
- Foundations for the creation of a network of experts in the field of FERs-CBR workers,
- Strengthening the role of Latin American Networks with major emphasis on inclusive approaches to disabilities and the needs to be included in International Development Programs. Developing Strategic Alliances and Partnerships.

Methodology of Work:

- Presentations of experiences by countries, organizations, and individuals.
- Submission of professional presentations for curriculum development within the FER session area.
- Discussion groups to explore specific subjects and submit proposals to improve access to health care and other areas prioritized for persons with disabilities.

Expected Outcomes:

- Feedback in the adaptation and/or development of FER-CBR models and course-related online materials for developing countries.
- Proposed mechanisms, strategies, and instruments to be applied in Latin America.
- Participants will receive a Compact Disc Resource Guide that includes software, sample of data, tools to increase awareness potential applications of FERs-CBR workers and their agencies, and a complete monograph of the conference.
- To provide all information, materials, targets, outcomes and results, etc. to be made available on PAHO's & CIR's Distance Education on-line programs.
- A third Regional conference: Evaluation and monitoring the effectiveness of FERs-CBR workers, as a key mechanism to improve the livelihood of persons affected by crisis in remote areas. Persons in the Latin American region will gain increased access to their basic fundamental and human rights through immediate assistance, delivery of health care, prioritized needs, post reconstruction and community involvement. These forms of access are essential components for International Development Programs.

Partners:

The Center for International Rehabilitation (CIR) is a non-profit organization that is "committed to helping people with disabilities worldwide reach their full potential." The CIR operates with the assistance of the U.S. Department of Defense's Telemedicine and Advanced Technology Research Center (TATRC) and the U.S. Department of Education's National Institute on Disability and Rehabilitation Research (NIDRR), and manages the Rehabilitation Engineering Research Center (RERC) on Improved Technology Access for Landmine Survivors. The RERC focuses its attention in the development of high-quality and low-cost mobility aids, rehabilitation technologies and education programs that improve the quality and availability of services for the survivors of land mines and other people with disabilities in low-income countries.

The Pan American Health Organization (PAHO/WHO) is the regional office of the World Health Organization (WHO) for the Americas and the specialized health agency of the Inter-American system. Among other things, PAHO is committed to supporting and strengthening institutional development to assist in the provision of health services and rehabilitation programs for landmine survivors and other persons with disabilities living in the Region of the Americas.

Requested Funding:

Total: Approximately US\$107185.12
a three day conference with attendees estimated
to be 80 persons.

Second Regional CIRNetwork Conference

Meeting of Experts: Reaching people's needs through first emergency responders; Building partnerships through technology and integrated rehabilitation

Managua, Nicaragua
Spring, 2004

**Panamerican Health Organization (PAHO)
Center for International Rehabilitation (CIR)**

In Attendance: CIRN Members, PAHO, TATRC, local authorities

Tentative Schedule Day One

- 8:30 a.m. Welcome remarks:
Representative Nicaraguan Ministry of Health and/or Defense
Representative - TATRC
- 9:00 a.m. Panamerican Health Organization (PAHO) Rehabilitation Programs
Armando Vasquez, M.D., PAHO
- 9:20 a.m. Overview of the Center for International Rehabilitation Network
Activities in the Latin American Region – William K. Smith, M.D.,
Chair CIR
- 9:40 a.m. Break
- 10:00 a.m. Prosthetics, Engineering and Education – Dr. Odor
Dilatancy Demonstration - Hector Casanova
- 10:30 a.m. Disability Rights – Maria Veronica
- 10:50 a.m. First Emergency Response – TBD
- 11:10 a.m. Telemedicine / Teleconsultation – TBD
- 11:30 a.m. Questions and Answers
- 12:00 p.m. Lunch
- 1:00 – 3:15 **Group A: Break-out Sessions on First Emergency Responders Curriculum**
Introduction to Process – Michael Potts
Casualty Evacuation and Stabilization TBD
Life and Limb Saving Surgery TBD
Acute and subacute pain management and optimization of chronic pain incidence NHarden
- Group B: Presentations & Demonstrations of RERC Engineering Products**
Component Testing Evaluation and Prosthetic Foot Design – TBD
Outcome Measures – Allen Heinemann, Ph.D.
Skeletal Alignment Principles and Monolimb Design

Group C: Disability Rights
UN Convention
IDRM Pilot Program
Paper presentations (IDRM Researchers)

Group D: Early Screening and Intervention

Group E: Telemedicine and Teleconsultation

3:15 p.m.

Break

3:45 p.m.

Group A: Break-out Sessions on First Emergency Responders Curriculum
Reconstructive Surgery TBD
Post-operative Care of Residual Limb YWu

Group B: Presentations and Demonstrations RERC Engineering Products

Socket Fabrication Techniques – Yeongchi Wu, M.D.

Wheelchair Design – Ralf Hotchkiss

Group C: Disability Rights

Group D: Early Screening and Intervention

Group E: Telemedicine and Teleconsultation

5:00 p.m.

First Day Meeting Adjourned

Tentative Schedule Day Two

- 9:00 a.m. **Group A:** Break-out Sessions on First Emergency Responders Curriculum
Group B: Presentations & Demonstrations of RERC Engineering Products
Group C: Disability Rights
Group D: Early Screening and Intervention
Group E: Telemedicine and Teleconsultation
- 10:30 a.m. Break
- 10:45 a.m. **Group A:** Break-out Sessions on First Emergency Responders Curriculum
Group B: Presentations & Demonstrations of RERC Engineering Products
Group C: Disability Rights
Group D: Early Screening and Intervention
Group E: Telemedicine and Teleconsultation
- 12:15 p.m. Lunch
- 1:30 p.m. **Group A:** Working session - First Emergency Responders Curriculum
Group B: Working session - RERC Engineering Products
Group C: Working session - Disability Rights
Group D: Working session - Early Screening and Intervention
Group E: Telemedicine and Teleconsultation
- 3:00 p.m. Break
- 3:20p.m. Reporting sessions for groups: (15min report; 5min Q&A)
Group A: Reporting session on First Emergency Responders Curriculum
Group B: Reporting session on RERC Engineering Products
Group C: Disability Rights
Group D: Early Screening and Intervention
Group E: Telemedicine and Teleconsultation
- 5:00 p.m. Closing Remarks – Armando and WKS
- 5:15 p.m. Meeting Adjourned

**CENTRO NACIONAL DE REHABILITACIÓN
DIVISIÓN DE REHABILITACIÓN ORTOPÉDICA
SERVICIO DE REHABILITACIÓN DE AMPUTADOS
LABORATORIO DE ÓRTESIS Y PRÓTESIS**

**PROGRAMA PARA EL CURSO ÓRTESIS DE MIEMBRO INFERIOR
EN TERMOPLASTICO**

Módulo 1– Anatomía Básica del Miembro Inferior.

- **Caso** – Presentación de caso/conferencia # 1. (imágenes)
- **Metas** – Al completar este módulo, deberá tener un entendimiento básico de los principios anatómicos necesarios para producir una órtesis hecha a la medida.
- **Objetivos** –
 - Aplicar el conocimiento de la anatomía de las extremidades inferiores cuando se evalúen las necesidades ortesicas en un paciente.
 - Deberá tener la capacidad de identificar las estructuras anatómicas y comprender sus funciones relativas. Ello incluirá:
 - Planos del cuerpo
 - Centro de gravedad
 - Términos de dirección
 - Osteología
 - Miología
 - Articulaciones
 - Inervación
 - Marcha
 -
- **Tareas** –

- Revisar la Presentación de Caso # 1.
- Leer el Módulo 1 – Anatomía del miembro inferior.
- Escribir comentarios y recomendaciones sobre las presentaciones de casos en el foro en línea.
- Atender la discusión en línea el viernes las 12:00 AM.
- Prueba # 1 sobre Anatomía.

Módulo 2 – Patología Básica de Miembro Inferior

- **Caso** – Presentación de caso/conferencia # 2. (Conferencia y Videos)
- **Metas** –Al completar este modulo, deberá tener un entendimiento básico de los las patologías que más afectan el miembro inferior, y en que patologías se aplicara una órtesis hecha a la medida.

- **Objetivos** –

- Al entender la patología básica de la extremidad inferior y aplicando el conocimiento de la anatomía, diseñará una órtesis hecha a la medida
- Entenderá que los impedimentos físicos pueden ser causados por: problemas de nacimiento, enfermedad , trauma y otras patologías como las que se mencionan a continuación:

Lesiones traumáticas:

Fractura Huesos

Esguinces

Luxaciones

- Neurona Motora Superior:

Lesión medular

Mielomeningocele,

Parálisis Cerebral Infantil

Enfermedad Vasculat Cerebral

Esclerosis Múltiple

- Lesiones De Neurona Motora Inferior:

Esclerosis lateral

Poliomielitis

Hemofilia

Pie equino varo y aducto

Distrofia Muscular

Neuropatía

- Metabólicas:

Osteogénesis imperfecta

Osteoporosis

Artritis Reumatoide

Osteoartritis

- Revisar el caso # 2.
- Leer el Módulo 2–Clasificación de las patologías que requieren de una órtesis de miembro inferior.
- Escribir comentarios y recomendaciones sobre la presentación de caso en el foro en línea.
- Atender la discusión en línea el viernes a las 12:00 AM.
- Prueba # 2 sobre las patologías y su clasificación que requieren de una órtesis de miembro inferior.

Módulo 3 – Terminología y Componentes Ortésicos en Miembro Inferior.

- **Caso** – Presentación de caso/conferencia #3.
- **Metas** – Al completar este módulo, deberá tener un entendimiento básico de los principios ortésicos necesarios para hacer una órtesis y los componentes para hacerla a la medida.

Conocerá las nomenclaturas más frecuentes que se manejan en las órtesis de miembro inferior
- Aprenderá sobre los componentes básicos de tobillo pie, sistemas de suspensión y sus criterios de selección.

- **Objetivos** –
 - Entenderá que la ortésica es una rama de la biotecnología, que trata de la aplicación de las fuerzas, a través de un dispositivo mecánico hacia el cuerpo humano para restaurar una función a individuos con impedimentos físicos.
 - Entenderá como aplicar las fuerzas apropiadas para controlar el movimiento alrededor de las articulaciones y para controlar las cargas axiales de los huesos largos.
 - Entenderá que las órtesis proporcionan una o mas de las siguientes funciones
 - Corrección del sistema músculo esquelético
 - Mantener una Posición
 - Asistencia para la movilidad de una articulación
 - Resistencia para la movilidad de una articulación
 - Disminuir la carga de peso para aliviar dolor o reducir cargas en el cuerpo o ambas
 - Protección
 - Entenderá la aplicación de de presión, para proporcionar cualquiera de las funciones anteriores una órtesis debe aplicar fuerzas a través de los tejido blandos del sistema músculo esquelético. Las unidades de presión deben ser reducidas tanto como sea posible repartiendo las fuerzas sobre el área más amplia posible.
 - Seleccionar las articulaciones de tobillo, y sistemas de suspensión y control para el paciente con requerimientos de una órtesis de miembro inferior.

- Un entendimiento de las propiedades de los materiales ortésicos hechos de acero inoxidable, aluminio, duraluminio y titanio.
- Deberá tener un entendimiento de las distintas partes y funciones de las órtesis y suspensión así como su clasificación.

ÓRTESES DE PIE.	OP	FO
ÓRTESES DE TOBILLO PIE	OTP	AFO
ÓRTESES DE RODILA TOBILLO PIE	ORTP	KAFO
ÓRTESES CADERA RODILLA TOBILLO PIE	OCRTP	HKAFO

Una órtesis que cubre únicamente la rodilla es simplemente una órtesis de rodilla OR.

- **Tareas –**

- Revisar la Presentación de Caso #3
- Leer el Módulo 3 – terminología y componentes ortésicos en miembro inferior.
- Escribir comentarios y recomendaciones sobre las presentaciones de casos en el foro en línea.
- Atender la discusión en línea el VIERNES s a las 12:00 AM.
- Prueba # 3 sobre terminología y componentes ortésicos en miembro inferior.

Módulo 4 – Evaluación Física del paciente para una Órtesis de Pie y Tobillo pie.

- **Caso – Presentación de caso/conferencia en línea # 4. Escrito y vídeo**

- **Metas** – Deberá ser capaz de evaluar la condición física y funcional del paciente y el miembro inferior.
- **Objetivos** – Determinar las necesidades del paciente utilizando una variedad de procedimientos de evaluación y técnicas de medidas.
 - Tendrá un entendimiento de la forma y la longitud del miembro inferior y como ello puede afectar el diseño y el talla ortésico.
 - Tendrá un entendimiento de las condiciones normales del miembro inferior, tales como tejido, piel, rango de movimientos, sensibilidad, fuerza muscular, la marcha y sus alteraciones.
 - Evaluar las condiciones especiales del paciente.
 - Desarrollar un plan de tratamiento ortésico adecuado.
- **Tareas** –
 - Revisar la presentación de caso # 4.
 - Leer el Módulo 4– Evaluación ortésica tobillo pie del paciente.
 - Escribir comentarios y recomendaciones sobre la presentación de caso en el foro en línea.
 - Atender una discusión en línea el viernes a las 12:00 AM.
 - Prueba # 4 sobre Evaluación ortésica tobillo pie del Paciente.

Módulo 5 – Toma de medidas de Órtesis de pie y tobillo pie .

- **Caso** – Presentación de caso/conferencia en línea # 5.
- **Metas** – Deberá ser capaz de identificar las prominencias óseas que servirán de referencia para una adecuada toma de medidas de órtesis de pie y tobillo pie.
- **Objetivos** – Determinar los puntos anatómicas para realizar órtesis

- Tendrá un entendimiento de las alteraciones normales del miembro inferior, tales como tejido, piel, rango de movimientos, sensibilidad, fuerza muscular, la marcha y sus alteraciones.
- Evaluar las condiciones especiales del paciente.
- Desarrollar un plan de tratamiento ortésico adecuado.

| Conocera el procedimiento adecuado para hacer la toma de medida.

- **Tareas –**

- Revisar la presentación de caso # 5.
- Leer el Módulo 5 – Toma de medida de ortésis pie y tobillo pie .
- Escribir comentarios y recomendaciones sobre la presentación de caso en el foro en línea.
- Atender discusión en línea el viernes a las 12:00 AM.
- Prueba # 5 sobre Toma de medida órtesis de pie y tobillo pie.

Módulo 6 – Modificación de Órtesis de pie y tobillo pie .

- **Caso –** Presentación de caso/conferencia en línea # 6.
- **Metas –** Identificar los puntos anatómicos para realizar la liberación de las prominencias óseas para una adecuada modificación de los moldes de órtesis de pie y tobillo pie.
- Aprenderá a alinear las órtesis al mismo tiempo que las modifica
- Será capaz de evaluar el funcionamiento adecuado de las órtesis de pie y tobillo pie.

- **Objetivos –**

- Desarrollar un plan de tratamiento ortésico adecuado de acuerdo a la patología que presenta el paciente en el pie y tobillo.

|

Conocer los puntos anatómicos para liberar las prominencias óseas para modificar órtesis

- Realizará la alineación adecuada una órtesis de pie y tobillo pie
- Aprenderá a corregirá las alteraciones que presente el paciente a través de las órtesis de pie y tobillo pie.

- **Tareas –**

- Revisar la presentación de caso # 6.
- Leer el Módulo 6 – Modificación de órtesis pie y tobillo pie .
- Escribir comentarios y recomendaciones sobre la presentación de caso en el foro en línea.
- Atender discusión en línea el viernes a las 12:00 AM.
- Prueba # 6 sobre la modificación de órtesis de pie y tobillo pie.

Módulo 7 – Fabricación de Órtesis Pie y Tobillo Pie.

- **Caso** – Presentación de caso/conferencia en línea # 7.
- **Metas** – Deberá ser capaz de Fabricar una órtesis de pie y tobillo pie.

- **Objetivos – .**

- Conocer los diferentes termoplásticos y las temperaturas a la cual se realizan y sus componentes.
- Conocer los cortes que lleva una órtesis de pie y tobillo pie de acuerdo a la patología que presente el paciente

- Conocer los diferentes tipos de órtesis para pie y tobillo pie de acuerdo a la patología.
- Conocer el proceso para la fabricación de órtesis de pie y tobillo pie

- **Tareas –**
 - Revisar el caso # 7.
 - Leer el Módulo 7 –Fabricación de una Órtesis de pie y Tobillo Pie.
 - Escribir comentarios y recomendaciones sobre la presentación de caso en el foro en línea.
 - Atender la discusión en línea el viernes a las 12:00 AM.
 - Prueba # 7 sobre Fabricación de una Órtesis de Pie y Tobillo Pie.

Módulo 8 – Ensamble, Ajuste y Suspensión de Órtesis tobillo Pie.

- **Caso –** Presentación de caso/conferencia en línea # 8.
- **Metas –** Deberá ser capaz de realizar el ensamble, ajuste y suspensión de una órtesis Tobillo Pie. Y ajuste de una órtesis de pie.
- **Objetivos –**
 - Conocer como se ensambla una órtesis tobillo pie
 - Conocer como se ajusta una órtesis tobillo pie.
 - Conocer como se realiza la suspensión en órtesis tobillo pie.
 - Conocer como se ajusta una órtesis de pie.

- **Tareas –**
 - Revisar caso # 8.
 - Leer el Módulo 8 – Ensamble, ajuste y suspensión de órtesis Tobillo Pie y ajuste de órtesis de pie.
 - Escribir comentarios y recomendaciones sobre la presentación de caso en el foro en línea.
 - Atender la discusión en línea el viernes a las 12:00 AM.

- Prueba # 8 sobre Ensamble, ajuste y suspensión de Órtesis Tobillo pie y Ajuste de órtesis de pie.

Módulo 9 – Evaluación Física del paciente para una Órtesis de rodilla tobillo Pie y cadera rodilla tobillo pie.

- **Caso** – Presentación de caso/conferencia en línea # 9.
- **Metas** – Deberá ser capaz de evaluar la condición física y funcional del paciente con alteración en cadera, rodilla, tobillo y pie y en marcha.
- **Objetivos** – Determinar las necesidades del paciente utilizando una variedad de procedimientos de evaluación y técnicas de medidas.
 - Tendrá un entendimiento de la forma y la longitud del miembro inferior y como ello puede afectar el diseño y el talle ortésico.
 - Tendrá un entendimiento de las condiciones normales del miembro inferior, tales como piel, tejido, rango de movimientos, sensibilidad, fuerza muscular, la marcha y sus alteraciones.
 - Evaluar las condiciones especiales del paciente.
 - Desarrollar un plan de tratamiento ortésico adecuado.
- **Tareas** –
 - Revisar la presentación de caso # 9.
 - Leer el Módulo 9– Evaluación del paciente para órtesis de cadera, rodilla, tobillo y pie.
 - Escribir comentarios y recomendaciones sobre la presentación de caso en el foro en línea.
 - Atender una discusión en línea el viernes a las 12:00 AM.
 - Prueba # 9 sobre Evaluación del paciente para órtesis de cadera, rodilla, tobillo y pie.

Módulo 10– Toma de medidas de Órtesis de rodilla tobillo pie y cadera rodilla tobillo pie .

- **Caso** – Presentación de caso/conferencia en línea # 10.
 - **Metas** – Deberá ser capaz de identificar las prominencias óseas que servirán de referencia para una adecuada toma de medidas de órtesis de rodilla tobillo pie y cadera rodilla tobillo pie.
 - **Objetivos** – Determinar los puntos anatómicos para realizar órtesis de rodilla tobillo pie y cadera rodilla tobillo pie.
 - Tendrá un entendimiento de las alteraciones normales del miembro inferior, tales como tejido, piel, rango de movimientos, sensibilidad, fuerza muscular, la marcha y sus alteraciones.
 - Evaluar las condiciones especiales del paciente.
 - Desarrollar un plan de tratamiento ortésico adecuado.
- | Conocera el procedimiento adecuado para hacer la toma de medida.
- **Tareas** –
 - Revisar la presentación de caso # 10.
 - Leer el Módulo 10 – Toma de medida de órtesis de rodilla tobillo pie y cadera rodilla tobillo pie.
 - Escribir comentarios y recomendaciones sobre la presentación de caso en el foro en línea.
 - Atender discusión en línea el viernes a las 12:00 AM.
 - Prueba # 10 sobre Toma de medida de órtesis de rodilla tobillo pie y cadera rodilla tobillo pie.

Módulo 11 – Modificación de Órtesis de rodilla tobillo pie y cadera rodilla tobillo pie.

- **Caso** – Presentación de caso/conferencia en línea # 11.
- **Metas** – Identificar los puntos anatómicos para realizar la liberación de las prominencias óseas para una adecuada modificación de los moldes de órtesis de rodilla tobillo pie y cadera rodilla tobillo pie.
- Aprenderá a alinear las órtesis al mismo tiempo que las modifica
- Será capaz de evaluar el funcionamiento adecuado de las órtesis de rodilla tobillo pie y cadera rodilla tobillo pie.

- **Objetivos** –

- Desarrollar un plan de tratamiento ortésico adecuado de acuerdo a la patología que presenta el paciente en la rodilla tobillo pie y cadera rodilla tobillo pie .

|

Conocer los puntos anatómicos para liberar las prominencias óseas para modificar la órtesis

- Realizará la alineación adecuada de una órtesis de rodilla tobillo pie y cadera rodilla tobillo pie
- Aprenderá a corregirá las alteraciones que presente el paciente a través de las órtesis de rodilla tobillo pie y cadera rodilla tobillo pie.

- **Tareas** –

- Revisar la presentación de caso # 11 .
- Leer el Módulo 11 – Modificación de la órtesis rodilla tobillo pie y cadera rodilla tobillo pie .
- Escribir comentarios y recomendaciones sobre la presentación de caso en el foro en línea.
- Atender discusión en línea el viernes a las 12:00 AM.
- Prueba # 11 sobre la modificación de órtesis de rodilla tobillo pie y cadera rodilla tobillo pie.

Módulo 12 – Fabricación de Órtesis rodilla tobillo Pie y cadera rodilla Tobillo Pie.

- **Caso** – Presentación de caso/conferencia en línea # 12.
- **Metas** – Deberá ser capaz de Fabricar una órtesis de rodilla tobillo pie y cadera rodilla tobillo pie.
- **Objetivos** – .
 - Conocer los diferentes termoplásticos y las temperaturas a la cual se realizan y sus componentes.
 - Conocer los cortes que lleva una órtesis de rodilla tobillo pie y cadera rodilla tobillo pie de acuerdo a la patología que presente el paciente
 - Conocer los diferentes diseños de órtesis rodilla tobillo pie y cadera rodilla tobillo pie de acuerdo a la patología.
 - Conocer el proceso para la fabricación de órtesis rodilla tobillo pie y cadera rodilla tobillo pie
- **Tareas** –
 - Revisar el caso # 12 .
 - Leer el Módulo 12 –Fabricación de una Órtesis rodilla tobillo pie y cadera rodilla Tobillo Pie.
 - Escribir comentarios y recomendaciones sobre la presentación de caso en el foro en línea.

- Atender la discusión en línea el viernes a las 12:00 AM.
- Prueba # 12 sobre Fabricación de una Órtesis de Pie y Tobillo Pie.

Módulo 13 – Ensamble, Ajuste y Suspensión de Órtesis tobillo Pie.

- **Caso** – Presentación de caso/conferencia en línea # 13.
- **Metas** – Deberá ser capaz de realizar el ensamble, ajuste y suspensión de una órtesis rodilla Tobillo Pie. Y cadera rodilla tobillo pie.
- **Objetivos** –
 - Conocer como se ensambla una órtesis rodilla tobillo pie y cadera rodilla tobillo pie.
 - Conocer como se ajusta una órtesis rodilla tobillo pie y cadera rodilla tobillo pie.
 - Conocer como se realiza la suspensión en la órtesis rodilla tobillo pie y cadera rodilla tobillo pie.
 - Conocer como se ajusta una órtesis rodilla tobillo pie y cadera rodilla tobillo pie.
- **Tareas** –
 - Revisar caso # 13.
 - Leer el Módulo 13 – Ensamble, ajuste y suspensión de órtesis rodilla Tobillo Pie y cadera rodilla tobillo pie .
 - Escribir comentarios y recomendaciones sobre la presentación de caso en el foro en línea.
 - Atender la discusión en línea el viernes a las 12:00 AM.
 - Prueba # 13 sobre Ensamble, ajuste y suspensión de Órtesis rodilla Tobillo pie y cadera rodilla tobillo pie .

Módulo 9–

-
-

IRN Advisory Council

Executive Chair

Don Smith
Faculty
Film and Video Department
Columbia College
600 S. Michigan Avenue
Chicago, IL 60605
dsmith@popmail.colum.edu

Education Content Panel

Sepp Heim
President
International Society for Prosthetics and Orthotics (ISPO)
ot-heim@t-online.de

Michael Brncick, C.P.O., C.Ped.
10213 Frankfort Main
Frankfort, IL 60423
mbrncic@attglobal.net

John G. Craig, C.P.O.
Nova Care
802 Via Del Sur
Mesquite, TX 75150-4312
jgcraig@flash.net

Terry Supan
Southern Illinois University School of Medicine
P.O. Box 19652
Springfield, IL 62794-9652
tsupan@siumed.edu

Mark Edwards
Faculty
Northwestern University Prosthetics and Orthotics Center
345 E. Superior, 17th Floor
Chicago, IL 60611
mle@nwu.edu

Instructional Design Panel

Steve Allen
President
Allen Communications
1189 South Sunset Road
Kaysville, UT 84037
801.546.7007
801.201.7554
SteveA@mentergy.com

Brooke Olson
Director, Executive Education
unext.com
500 Lake Cook Road, Suite 150
Deerfield, IL 60015-5609
bolson@unext.com

Janice Garfield, PhD
Associate Provost
Columbia College Chicago
600 S. Michigan Avenue
Chicago, IL 60605
312.344.7495
jgarfield@popmail.colum.edu

Platform/Delivery Panel

Jason Schreiber
Control Room Technologies
1223 Turner St.
Lansing, MI 48906
(517) 346-5041x300
jason@crt.net

LoriLee M. Sadler
Vice President and Chief Technology Officer
unext.com
500 Lake Cook Road, Suite 150
Deerfield, IL 60015-5609
sadler@unext.com

Paul Meyer
Chairman and CEO
Voxia
Markel Foundation
10 Rockefeller Plaza, 16th Fl
New York, NY 10020-1903
(212) 214-0888
(917) 385-8555
paul@voxia.net

Brian Nielsen
Northwestern University Information Technology Department
1935 Sheridan Road, 2 East
Evanston, IL 60208-2323
(847) 491-2170
b-nielsen@northwestern.edu

IRN ADVISORY COUNCIL SCOPES OF WORK

Instructional Design Advisory Panel

1. Evaluate syllabus
2. Evaluate assessment
3. Evaluate design and effectiveness of module set including:
 - Goals & objectives
 - Pre-tests
 - Weekly on-line case presentations
 - Assignments
 - Including the technical brief
 - Chat room discussions
 - Case presentation
4. Suggest & evaluate methods of adapting existing linear didactic materials to problem based learning
5. Suggest methods of tracking students during off-line components of DL

Platform/Delivery Advisory Panel

1. Evaluate & when appropriate suggest possible alternatives to in-country, on-line connectivity
2. Evaluate third-party or exterior application integration with WebCT
3. Evaluate & suggest integration of hybrid media delivery technologies
4. Suggest model for creating on-/off-line help desk database to supplement staffed help desk
5. Suggest audio streaming applications
6. Evaluate the feasibility of delivering database-driven content

Education Panel

1. Responsible for review and evaluation of educational content of distance education course materials
2. Ensure course materials are appropriate for website distribution
3. Ensure clarity of educational goals of program
4. Assist with development of student evaluation tools
5. Develop international prosthetic and orthotic educational standards
6. Assist in revising content for different audiences (continuing education content versus degree program content)
7. Suggest & evaluate case studies that will assist in adapting existing curriculum materials to problem based learning

The CIR will coordinate with panel members a **quarterly teleconference** beginning mid January 2002. Background materials will be mailed to each panel member two weeks prior to the first teleconference. Each member is asked to complete an independent **review of the materials** and **document suggestions** in a brief memo that will be sent to the panel chair.

Based on the summary of comments, the respective panel chair and the executive advisory council chair will draft an agenda, which will be circulated prior to each teleconference. In addition, each panel member will be asked to spend **1 to 2 hours every 3 months** reviewing topics on-line related to his/her particular scope of work.

Executive Summary Meeting IRN Advisory Council Education Panel

Participants

Sepp Heim, Chair CIR Education Panel
Terry Supan, Member CIR Education Panel
Mike Quigley, Member CIR Education Panel
Yeongchi Wu, CIR Chicago
Christian Schilerf, CIR Balkans
Fred Navarrete, CIR Central America
Hector Casanova, CIR Chicago

Highlights of the meeting:

1. The first meeting of the Education Panel was organized by the CIR and it was held in San Salvador the 13th of December 2002. The agenda of the meeting covered the following topics:

Responsibilities of the International Rehabilitation Network's (IRN) Advisory Council
Advisory Council Progress Report
Overview CIR's Distance Learning Program
Distance Learning Three Year-Curriculum
Entry/Exit Evaluations
Guidelines for Content Review

2. An overview of the functions of the CIR's Advisory Council, i.e., the Instructional Design, Platform/Delivery and Education Panel, was provided to members of the Education Panel. It was proposed that a meeting with members of the three panels be organized in April of 2003 in Chicago. Information regarding the Executive Chair of the Advisory Board was provided and the desire to initiate communication between the Executive Chair and the Chair of Education Panel was mentioned.

3. The participant reviewed the Scope of Work of the members of the Education panel and agreed to perform the following:

The panel is responsible for development, review and evaluation of prosthetics and orthotics educational content

Ensure clarity of educational goals of program according to ISPO guidelines*

Ensure course materials are appropriate for website education
Assist with development of student evaluation tools
Assist in reviewing content for different audiences
Suggest and evaluate clinical presentations that will assist in adapting existing curriculum materials to problem based learning

** CIR plans to coordinate with U.S. based groups and to pursue NCOPE accreditation.*

4. **Transfemoral Module Set** Berkely Brims may not be appropriate because some centers in the region do not have access to this technology and this could affect their ability to learn and applied the principles/techniques included in the content. An academic and constructive discussion between the U.S. and European teaching methodology lead to the agreement that "hand casting skills" (e.g., CIR's Ischial Containment Module Set) will be incorporated into the Transfemoral Module Set and that the section on the Berkely brims, and a new section on "hand casting skills" for quadrilateral sockets, will be added as an addendum to the Transfemoral Module Set.

It was proposed that both techniques (ischial containment and quadrilateral) be taught, and that in the future emphasis will be given to the ischial containment technique.

Other specific recommendations include:

- Adding a section on the references used in the development of the module sets
- Incorporate sections adapted from University of California Los Angeles (UCLA) and New York University (NYU) prosthetic manuals on the principles and biomechanics of the quadrilateral sockets.
- Consider adding a section on hand casting and modification of the "negative mold" (quadrilateral). Original versions used in teaching the wooden quadrilateral sockets could be used as reference.
- Alignment principles and different biomechanical requirements for different levels of transfemoral amputee (e.g., short vs. long TF)

5. **Evaluations**

Information was provided regarding the entry (i.e., written and practical) evaluation scheduled for January 2003 for the Upper Extremity Prosthetic Distance Learning Program. Practical evaluations - The Chair thinks that CIR' practical evaluation process are appropriate and should continue as planned.

Also, an invitation to participate in the final evaluation of the distance learning program in the Balkans was extended to the Chair, and The possibility of obtaining ISPO recognition for the training will also be explored as part of this process.

Regarding Don Bosco University's distance learning program, the Chair believes that there is currently no duplication of effort. CIR is working on continuing education and UDB is developing a degree program. Both programs could continue to develop distance learning methodologies independently, at the end this would help analyze the impact of the programs. CIR representative asked if he could provide some information regarding UDB's approach, particularly, since he has had the opportunity to assess the results of CIR's Pilot and at the same time has been involved in the development of Don Bosco's University distance learning program. At this point no feedback was provided. However the Chair stated that there UDB and CIR are the only organizations in the world working on distance learning. That initiatives in Australia and other universities were not truly distance learning but rather a "copy and paste" from existing books exercise.

The way we are currently developing content and distance learning initiatives should be protected. International organizations are waiting for Don Bosco University and the CIR to finish developing content to appropriate the training materials.

Members of the Education Panel feel that we are at the beginning of a new era and that we are pioneers. No significant changes have been made in the way prosthetics/orthotics is taught since the end of Second World War, and this innovative approach will be an important contribution to the field. Since most of theoretical materials can be delivered via web based distance learning format, it potentially will shorten the actual classroom learning from three years to one year.

Balkans. An invitation was extended to the Chair to participate in the final evaluation of the CIR distance learning program in the Bosnia. When asked if ISPO could acknowledge the training done under our continuing education program in Bosnia, he responded affirmatively.

Follow up. The Chair also suggested having a meeting next year in Chicago

**Coordination Meeting with GTZ and ISPO
Saturday December 14, 2002**

Participants: Sepp Heim, President ISPO
 Yeongchi Wu, CIR Chicago
 Heinz Trebbin, GTZ El Salvador
 Hector Casanova, CIR Chicago

Purpose: To explore potential collaboration between Don Bosco University and CIR's Three Year Distance Learning Program in the Latin American region.

Highlights of the Meeting:

UDB is currently developing a distance learning program for the Latin American region. They have approximately 36 students, 16 from Mexico, 6 or 7 from Central America, x from Colombia and x from Argentina. To date, they have completed the first semester which covers transtibial prosthetics and related subjects. UDB is planning a practical and written evaluation that will take place in Mexico, Colombia and El Salvador. No on-line evaluations have been done. If students complete all five modules, they will be able to go through a five-week practical & theoretical exam at UDB (includes written and practical), under the supervision of ISPO and obtain Category II status.

A CD ROM and VHS are distributed among the trainees. The CD ROM has the content and the VHS describes the casting and fabrication process. A printed version of the material will be available for sale. Content in the area of anatomy, and other related subjects have been adapted from UDB text books. The practical part has been adapted for web distribution. A delivery platform, similar to WebCT has been developed and is being used by the trainees. The tuition for each module is \$500.00.

The possibility of UDB and CIR collaborating in the development of a three-year curriculum was discussed. This joint program would be under the umbrella of the ISPO. CIR would have rights over English speaking countries and UDB over Spanish speaking. UDB would be responsible for the selection of students and delivery of the content.

In the past, a concern regarding the legal clause included in the Request for Proposal (RFP) was raised by UDB's lawyers. If an agreement can be reached regarding the intellectual property and distribution rights of the content, they (Sepp and Heinz) would be supportive of this joint venture.

Sepp Heim also suggested inviting Heinz to join CIR Education Panel, and mentioned that he would like to invite one more person to join the Panel.

Next Steps:

Heinz will consult with UDB authorities to revisit the potential collaboration between the two organizations.

CIR to decide if this prospect is still open

CENTER FOR INTERNATIONAL REHABILITATION
Annual Report to the Department of Defense
#DAMD17-00-1-0711

APPENDIX B

Spanish Regional Newsletter (English and Spanish)

INTERNATIONAL REHABILITATION



NEWS

NEWSLETTER OF THE CENTER FOR INTERNATIONAL REHABILITATION

Center for International Rehabilitation Network

Fred Navarrete
CIR Network Regional Coordinator

As part of its strategic objectives, the Center for International Rehabilitation formed the Center for International Rehabilitation Network, a network of people, local and regional institutions that work in the rehabilitation field. The CIR Network is an innovative resource where all the actors in the rehabilitation field can use to collaborate, share information, and benefit from others' knowledge. Through this network, service providers, consumers, and advocacy groups for people with disabilities have the ability to exchange concerns, knowledge, technologies, etc.

In Latin America, there was not a resource of this type that could transcend the borders of the countries; despite speaking the same language and sharing similar cultures, for many years there have been deficiencies in the communication mechanisms between similar institutions.

The CIR Network tries to alleviate the existing need of having precise and updated information regarding new technologies, proved methods used worldwide, and for a space to meet other people and institutions working to provide rehabilitation services to people who need it.

The CIR Network is designed so that the spread of information is performed through information technology and modern communications. These technologies include the Internet, on-line chat, discussion forums, and e-mail lists, as well as printed material.

CIR Network Services

The services available to CIR network members range from the publication of personal and institutional contact information in benefit of other members of the region, participation in discussion forums of cases presented by the CIR or by members of the network, to participating in continuous distance education programs.

Regional Rehabilitation Resources Directory
Once every member of the network is registered, it may provide and update personal and institutional contact information, geographic coverage, and services offered. This information is compiled and stored in a database available in the CIR website along with a search engine that allows locating service centers in the region through diverse criteria.



Technicians from Central America on the Ischial Containment Prosthetics Module Workshop in San Salvador, El Salvador, December 2002.

Distance Learning

In collaboration with Northwestern University and the Chicago Rehabilitation Institute, the CIR has developed training modules in prosthetics and orthotics. Since May 2001 a total of 24 prosthetics and orthotics technicians from Guatemala, El Salvador, and Nicaragua are being trained in the Lower Extremity Prosthetics Course and the Upper Extremity Prosthetics Course.

International Disability Rights Monitor

The International Disability Rights Monitor is an initiative of the International Disability Alliance and the CIR to document in every country the progress, problems, and barriers experienced by people with disabilities around the world. The members of the CIR Network may register to participate as local researchers within their country to contribute to this global effort.

How to register to the CIR Network?

1. Visit <http://www.cirnetwork.org>
2. Select the "CIR Network" link
3. Select the "Register" link.

International Disability Rights Monitor

María Verónica Reina
IDRM Regional Coordinator

The International Disability Rights Monitor (IDRM) is an annual report proposed to document the progress, problems, and barriers experienced by people with disabilities in their respective countries. The objectives of the IDRM project are to promote the full inclusion and participation of people with disabilities in society and to advance in the international area of human rights to ensure that the rights of people with disabilities are respected and all dispositions on the issue are fulfilled.

The IDRM's mission is being carried out through a vast training of the investigators, the collection of data, and their analysis and distribution. Phase I of the IDRM already began, and will run for approximately 18 months, between January 2003 and June 2004, focusing on the countries of the Caribbean, Latin America, and North America. The Center for International Rehabilitation (CIR) has carried out test trials of the investigation instrument in Nicaragua and El Salvador. This activity was completed recently, and the results are more than satisfactory. Investigators, people with disabilities, and local NGOs have been able to collect very valuable information that describes in depth the situation of people with disabilities in those countries. The corresponding reports will be published in April.

It is worth mentioning that an announcement for new investigators is being distributed to the remaining 26 countries in the hemisphere. Our objective is to have investigators that will be elected among the most prominent promoters of the rights of people with disabilities in the region.

During Phase I of the project, the investigators will meet to assist to two important regional training workshops sponsored by the CIR to develop their investigation skills and promotion of the rights of people with disabilities. The first of these workshops will be executed alongside the regional consultation of the Ad Hoc Committee in Quito, Ecuador in April of 2003. The second workshop will be executed alongside the meeting of the Ad Hoc Committee in the United Nations headquarters in New York City.

The CIR is currently committed in a dialog with representatives of the Pan-American Health Organization to join in the training workshops in the Americas. The timing and location of both workshops will



Training Session for the Local Researchers of the "International Disability Rights Monitor". Research Guide Validation. San Salvador, El Salvador. January 2003.

allow the investigators to be active participants of the Ad Hoc Committee process. The IDRM investigators will be firsthand witnesses of the Ad Hoc Committee process and will have the opportunity to take that knowledge back to their countries to share it with other promoters of the rights of people with disabilities at the local level.

Finally, the IDRM report about the rights of people with disabilities in the Americas will be published and widely distributed among governmental organizations, inter-governmental organizations, and non-governmental associations, the media, and the United Nations agencies. An accessible on-line database guarantees that this topical, timely information is easily available to interested parties. This way, the IDRM project is inscribed as an instrument of both action and investigation, not only providing in-depth knowledge regarding disability in the region, but also, and more importantly, generating an element that could be used actively in the defense of this group's rights.



Evaluation Session of the International Disability Rights Monitor (IDRM) Phase I, Local Researchers from Nicaragua and El Salvador. Managua, Nicaragua, Marzo 2003.

Early Detection of Disabilities

Désirée Román
FACES Program Coordinator

The Pan-American Health Organization/World Health Organization (PHO/WHO) and the Center for International Rehabilitation (CIR) carried out an International Meeting of Experts in Early Detection of Disabilities in children below the age of 6. The event took place in Managua, Nicaragua from September 30th to October 2nd, 2002. Experts on the topic from Chile, Venezuela, Argentina, Nicaragua, Cuba, Jamaica, and the USA participated. Fifty officers from national and international organizations, and officers from the Social Cabinet of the Nicaraguan Government attended. During the meeting,

This work was funded by the National Institute on Disability and Rehabilitation Research (NIDRR) of the Department of Education under grant number H133E980031. The opinions contained in this publication are those of the grantee and do not necessarily reflect those of the Department of Education.

instruments (guidelines) were identified, as well as early detection strategies, and the adaptation of evaluation models for the region was evaluated.

As a result of the meeting, in October and November, the CIR, in coordination with the National Community-Based Rehabilitation Commission (RBC), integrated by "Los Pipitos" Parents' Association, and the Ministries of Education, Culture and Sports, and Health and Family, carried out a pilot activity of two instruments presented in the expert's meeting for early detection of disabilities. The purpose of the pilot activity was to evaluate the suitability and effectiveness of the instruments in the Nicaraguan context.

Before the pilot activity, 22 RBC workers received training of the CIR to manage the instruments - "The Ten Questions" (Durkin, et. al. 1990) and "Ages and Stages: A Completed Questionnaire for Parents" (Bricker y Squires, 1988). "The Ten Questions", considered culturally appropriate, are simple questions about child development to detect serious disabilities in the cognitive, motor, visual, audio, and neurological (convulsions) areas in children aged between 2 and 9. The questionnaire "Ages and Stages" is derived from parent's observations of their children's development and their comparison to other children in their neighborhood. This questionnaire allows the early detection of delayed development and other disabilities in children aged from 4 to 60 months, and to monitor the child's progress. The questions are simple, illustrated, and based on daily activities of childhood. During the training, the RBC workers carefully reviewed the questions and the questionnaire, and made valuable contributions for their adaptation to Nicaragua.

To administer the "Ten Questions" to parents, 5 health centers were chosen in Managua that were able to provide follow-up to children that were detected as high-risk or with a disability. Parents who arrived at these health centers for vaccination or medical examinations of their children were invited to participate in the activity. To confirm the results of the "Ten Questions" of the children who were detected with alert signs or disabilities, follow-up was provided in their homes, providing the parents with "Ages and Stages: A Completed Questionnaire by Parents to Evaluate Children." One the pilot activity was over, a meeting was held with the entire team that participated in the investigation so as to share experiences and feedback about the instruments.

One of the conclusions of the pilot study was the interest of participants in promoting the use of these instruments in child development and pre-school centers. In addition, the Health Ministry



Small Work Groups during the International Expert Meeting on Early Detection on Disabilities of Children of Age 0-6, Managua, Nicaragua.

participants stated their interest in including the "Ten Questions" in health centers as part of their mother-infant program. Another result of the pilot activity was the decision to design and implement a training program for the ministries and organizations in Nicaragua that wish to carry out early detection activities. The procedures that will be recommended in the training will be based upon the experience acquired during the early detection pilot activity and the recommendations of the RBC workers (Pilot Study Report, 2002). The training will take place by mid-year and participants will include RBC workers and from other organizations.

ACTIVITIES IN CENTRAL AMERICA

Workshop "Educating through Art", September 2001 to March 2002.

Transfemoral Prosthetics Module On-Site Final Evaluation, January 7-18, 2002.

Field Trials of "Shape & Roll Prosthetic Feet" Research, April to June 2002.

Training on the Instrument Use for "Outcomes Measures of Prosthetic Services offered to People with Disabilities Central América", April 2002.

"Economic Model of Prosthetic Services" Instrument Validation, June 2002, FUNTER, El Salvador

Transfemoral Prosthetics Module On-Site Final Evaluation Final, June 24 to July 5, 2002.

Field Trial of the Instruments for "Outcomes Measures of Prosthetic Services offered to People with Disabilities Central América", July 15, 2002 to July 14, 2003.

Use of the "CIR Casting System" Training Workshop, August 20-23, 2002.

International Expert Meeting on "Early Detection of Disabilities of Children of Age 0-6", September 30 to October 2, 2002.

Early Detection of Disabilities Training and Screening Program using the Instruments "Ten Questions" y "Ages & Stages", October and November, 2002.

First Educational Panel Meeting, CIR Distance Learning Program, December 3, 2002.

Ischial Containment Prosthetics Module Workshop, December 17-19, 2002.

Training Session for Local Researchers of the "International Disability Rights Monitor", January 13-18, 2003.

Transradial Prosthetics Module Entry Evaluation, January 3 to 30, 2003

Evaluation Session of the Research Guide of the "International Disability Rights Monitor" Program, March 4-5, 2003.

renewing human potential. renewing human potential. renewing human potential. renewing human potential. renewing human potential.

The CIR is a not-for-profit organization that develops technologies and programs to help people with disabilities worldwide reach their full potential. Based in Chicago, the CIR operates in collaboration with the Rehabilitation Institute of Chicago, Northwestern University Prosthetic Orthotic Center and the Department of Veterans Affairs Chicago Health Care System. The CIR is an outgrowth of Physicians Against Land Mines (PALM) and, with support from the U.S. Department of Education's National Institute on Disability and Rehabilitation Research, the CIR functions as the Rehabilitation Engineering Research Center (RERC) on Improved Technology Access for Land Mine Survivors. The RERC is focused on the development of high-quality, low-cost mobility aids, rehabilitation technologies, and education programs that improve the quality of services available to land mine survivors and people with disabilities in developing countries.

Center for International Rehabilitation



**Center for
International
Rehabilitation**

Regional Office
Calle El Pedregal y Av. L-E,
Jardines de la Hacienda,
Ciudad Merliot,
Antiguo Cuscatlán.
El Salvador, C.A.



Technical Brief

A forum for sharing something "better, cheaper and faster."

Verrucose Hyperplasia: A Problem from Open-end Prosthetic Sockets.

Yeongchi Wu, M.D.

Human skin serves as a boundary between the body and its surrounding environment. It protects the internal organs and is the first barrier against infectious organisms. For the amputee, skin of the residual limb has another important function in bearing the mechanical stress from wearing the prosthetic device.

The skin consists of two distinct layers, the "epidermis" and the "dermis". Under these two layers is another layer of subcutaneous tissue. The dermis is thicker than the epidermis and provides strength and limited elasticity to the skin. It contains connective tissue, such as collagen fibers, that support glands, hair follicles, blood vessels, lymphatic vessels, and nerves. The epidermis is a nonvascular tissue. There are four sub-layers in the epidermis. Its deeper cells are nourished from extracellular fluid supplied from the vascular dermis underneath. In the inner most layer of the epidermis is basal cell, which grows into outer epidermal cells. The outer layer of epidermis are dead cells, which are flat, plate-like envelopes filled with keratin and held together by a cementing material in thickness from 15 to 25 layers. It makes the skin tough and elastic.

Under normal condition, oxygen-rich tissue fluid from the blood vessels to the capillaries circulates between the tissue cells, provides them with vital oxygen and nutrients, and is then returned to venous capillaries and lymphatic vessels. Amputation surgery disrupts this normal circulation causing accumulation of tissue fluid (edema) in the site of amputation. Post-operative edema can be prevented by proper application of gradient compression with more pressure proximally than distally. This reduces fluid coming through arterial capillaries into the tissue where drainage is impaired.

In open-end socket design, compression occurs mostly around the proximal area of the residual limb while no contact occurring in the distal end. The proximal constriction will cause shrinkage in the proximal but swelling (edema) in the distal portion.

Normally, the surface layer of the skin (dead cells with keratin) is constantly removed by natural actions such as friction against clothing or washing. If the keratin is not removed under certain conditions, for example, inside a fracture cast or an open-end prosthetic socket, it accumulates, growing thicker and thicker. As keratin becomes thicker, drier and less flexible, edema in the surrounding areas or weight bearing during walking might stretch it to tear. Tearing of the thick layer of keratin along with underlying epidermis leads to oozing and bleeding. With increased moisture, secondary infection sets in and the soft tissue around it becomes red and inflamed. This has a hyperkeratotic (too much keratin) wart-like appearance: verrucose hyperplasia.

Treatment of verrucose hyperplasia includes: 1) Controlling infection with oral and topical antibiotics based on the culture and sensitivity

test of the drainage, 2) Softening the hyperkeratotic mass with keratotic agent, such as 6% salicylic acid in cream or petroleum base, and, 3) Applying total contact compression dressing to the residual limb (using removable rigid dressing, which will be described in detail in a future Technical Brief). When distal edema improved, provide a new prosthesis with a total contact socket.

Consulting with a dermatologist is advised for proper treatment for severe verrucose hyperplasia, which might include:

1. Soak the stump in 1/40 Burrough's solution (one tablet of Domeboro in a quarter of water) for 15 minutes twice a day.
2. Wipe with sterile gauze.
3. Then apply 6% salicylic acid in Acid Mantle cream for half an hour to one hour, twice a day.
4. Wipe with sterile gauze and apply Neosporin cream then dry sterile dressing, twice a day.

Again, the primary cause of verrucose hyperplasia is lack of compression in the distal area and excessive constriction pressure in the proximal area of the residual limb in an open-end socket. This dermatological problem is rarely seen in patients that have been fitted with a total contact socket.

Reference

Levit, F: Skin problems in amputees, Chapter 31, Atlas of Limb Prosthetics, C.V. Mosby Co., 1981.

"**Technical Brief**" is a forum for discussion of innovative prosthetic procedures especially that are simple, practical and feasible for low income countries. Anyone who has experienced success with a unique solution to a specific common problem is encouraged to submit it for consideration of publication here. We believe in the principle of "share to benefit the people with disabilities". Credit will be given to whomever submits the original idea. Please have patentable ideas protected before submission.

NOTICIAS



DE REHABILITACION INTERNACIONAL

BOLETIN DEL CENTRO PARA LA REHABILITACION INTERNACIONAL

La Red del Centro para la Rehabilitación Internacional

Fred Navarrete
Coordinador Regional de la Red CIR

El Centro para la Rehabilitación Internacional formó como parte de sus objetivos estratégicos la Red del Centro para la Rehabilitación Internacional, una red de personas, instituciones locales y regionales que trabajan en el campo de la rehabilitación. La Red CIR es un recurso innovador donde todos los actores en el área de la rehabilitación pueden colaborar, compartir información y beneficiarse del conocimiento de otros. A través de esta Red los proveedores de servicios, consumidores, grupos que abogan por las personas con discapacidad tienen la capacidad de intercambiar inquietudes, conocimientos, tecnologías, etc.

En Latinoamérica no se contaba con un recurso de este tipo que trascienda las fronteras de los países, que aunque hablamos el mismo idioma y compartimos culturas muy similares, ha existido por muchos años deficiencias en los mecanismos de comunicación entre instituciones afines.

La Red CIR trata de aliviar la necesidad que existe de contar con información pronta y actualizada de nuevas tecnologías, de métodos probados y utilizados globalmente y de un espacio para conocer a otras instituciones y personas que trabajan para llevar la rehabilitación a las personas que lo necesitan.

La Red CIR esta diseñada para que la diseminación de la información se realice a través del uso de las tecnologías de información y de telecomunicaciones modernas. Estas tecnologías incluyen el uso del Internet, charlas en línea, foros de discusión, listas de correo electrónico, además de materiales impresos.

Servicios de la Red CIR

Los servicios que están disponibles para los miembros de la Red CIR van desde publicar información de contacto personal e institucional para beneficio de otros miembros de la región, participar en foros de discusión de casos presentados por CIR o por miembros, hasta participar en programas de formación continua a distancia.

Directorio Regional de Recursos de Rehabilitación

Una vez registrado cada miembro de la Red puede proveer y actualizar la información de contacto personal e institucional, cobertura geográfica, servicios ofrecidos. Esta información es compilada y almacena en una base de datos que esta disponible en el sitio web



Técnicos centroamericanos realizando sus prácticas durante el Taller Técnico-Práctico de Prótesis Transfemoral Tipo Isquicocontenido realizado en San Salvador, El Salvador

del CIR junto con una herramienta de búsqueda que permite ubicar centros de servicio en la región a través de diversos criterios.

Educación a Distancia

En colaboración con la Universidad Northwestern y el Instituto de Rehabilitación de Chicago, el CIR ha desarrollado módulos de entrenamiento en el área de prótesis y órtesis. Desde Mayo del 2001, 24 técnicos protesistas y ortesistas de Guatemala, El Salvador y Nicaragua están siendo entrenados en el Curso de Prótesis de la Extremidad Inferior y el Curso de Prótesis de Extremidad Superior.

Monitoreo Internacional de los Derechos de las Personas con Discapacidad

El Monitoreo Internacional de los Derechos de las Personas con Discapacidad es una iniciativa de la Alianza Internacional de Discapacidad y el CIR para documentar, en cada país, el progreso, los problemas y barreras que experimentan con discapacidad alrededor del mundo. Los miembros de la Red CIR pueden registrarse para participar como investigadores locales dentro de su país y contribuir a este esfuerzo global.

¿Cómo registrarse en la Red CIR?

1. Visite <http://www.cirnetwork.org>
2. Seleccione el enlace "Red CIR"
3. Seleccione "Registro" para registrarse.

Monitoreo Internacional de los Derechos de las Personas con Discapacidad

María Verónica Reina
Coordinadora Regional del IDRM

El Monitoreo Internacional de los Derechos de las Personas con Discapacidad IDRM es un informe anual propuesto para documentar el progreso, los problemas y las barreras que experimentan las personas con discapacidad en sus respectivos países. Los objetivos del proyecto IDRM son promover la plena inclusión y participación de las personas con discapacidad en la sociedad y avanzar en el área internacional de los derechos humanos para asegurar que los derechos de las personas con discapacidad sean respetados y se cumplan todas las disposiciones al respecto.

La misión del IDRM se está llevando a cabo a través de un vasto entrenamiento de los investigadores, de la recolección de datos, y del análisis y distribución de los mismos. La Fase I del IDRM ya comenzó y ocupará un plazo de alrededor de 18 meses, entre enero de 2003 y junio de 2004 centrándose en los países del Caribe, América Latina y Norteamérica. El Centro para la Rehabilitación Internacional (CIR) ha realizado una prueba del instrumento de investigación en los países de Nicaragua y El Salvador. Este trabajo ha sido culminado recientemente, y los resultados arrojados son más que satisfactorios. Los investigadores, personas con discapacidad y colaboradores pertenecientes a ONG locales, han podido recoger información muy valiosa que describe con profundidad la situación de las personas con discapacidad en dichos países. Los informes correspondientes serán publicados en el mes de abril.

Cabe destacar que una convocatoria para nuevos investigadores está siendo distribuida a los 26 países restantes del hemisferio. Nuestro objetivo es contar con investigadores que serán elegidos entre los promotores más destacados de los derechos de la discapacidad en la región.

Durante la Fase I del proyecto, los investigadores serán reunidos para asistir a dos importantes talleres de entrenamiento regional bajo el patrocinio del CIR en orden a desarrollar sus habilidades de investigación y promoción de los derechos de las personas con discapacidad. El primero de esos talleres se realizará en paralelo a la consulta regional del Comité Especial en Quito, Ecuador en abril



Sesión de entrenamiento para Investigadores locales de El Salvador. Validación del Instrumento de Investigación. San Salvador, El Salvador. Enero 2003.

de 2003. El segundo taller tendrá lugar paralelamente con la reunión del Comité Especial en junio de 2003 en la sede de las Naciones Unidas en Nueva York. El CIR actualmente está activamente comprometido en un diálogo con representantes de la Organización Panamericana de la Salud para articular los talleres de entrenamiento en las Américas. El momento y la ubicación de ambos talleres permitirán a los investigadores ser activos participantes en el proceso del Comité Especial. Los investigadores del IDRM serán testigos directos del proceso del Comité Especial y tendrán la oportunidad de llevar ese conocimiento de vuelta a sus países para compartirlo con otros promotores de los derechos de las personas con discapacidad a nivel local.

Finalmente, el informe del IDRM sobre los derechos de las personas con discapacidad en las Américas se publicará y distribuirá ampliamente entre las organizaciones gubernamentales, intergubernamentales y no gubernamentales, los medios de comunicación y el sistema de las Naciones Unidas. Una base de datos on line accesible garantizará que dicha información tópica y a tiempo esté disponible con facilidad para las partes interesadas. De este modo, el proyecto IDRM se inscribe como un instrumento de investigación-acción, no sólo ahondando el conocimiento en materia de discapacidad en la región sino y sobre todo, generando un elemento que podrá ser vivamente utilizado en la defensoría de los derechos de este colectivo.



Sesión de Evaluación de la Fase I del Programa de Monitoreo Internacional de los Derechos de las Personas con Discapacidad (IDRM), con la participación de investigadores locales de Nicaragua y El Salvador. Managua, Nicaragua, Marzo 2003.

Detección Temprana de Discapacidades

Desirée Román
Coordinadora del Proyecto FACES

La Organización Panamericana de la Salud / Organización Mundial de la Salud (OPS/OMS) y el Centro para la Rehabilitación Internacional (CIR) realizaron una Reunión Internacional de Expertos en Detección Temprana de Discapacidades en niños y niñas menores de 6 años. Dicho evento se llevó a cabo en Managua, Nicaragua del 30 de Septiembre al 2 de Octubre del 2002. Participaron expertos en el tema procedentes de Chile, Venezuela, Argentina, Nicaragua, Cuba,

Este boletín fue financiado por el "National Institute on Disability and Rehabilitation Research" (NIDRR) del Departamento de Educación de los Estados Unidos, bajo el donativo número H133E9800031. Las opiniones expresadas en esta publicación son aquellas del receptor del donativo y no necesariamente refleja la opinión del Departamento de Educación.

Jamaica y E.E.U.U. Asistieron a la reunión 50 profesionales de organismos nacionales e internacionales, y funcionarios del Gabinete Social del Gobierno de Nicaragua. Durante la reunión se identificaron instrumentos (guías), y estrategias de detección temprana, y se valoró la adaptación de modelos de detección para la región. Como resultado de la reunión, en Octubre y Noviembre, el CIR, en coordinación con la Comisión Nacional de Rehabilitación con Base en la Comunidad (RBC), integrada por la Asociación de Padres de Familia "Los Pipitos" y los Ministerios de Educación, Cultura, y Deportes, Salud y Familia; llevó a cabo un pilotaje de dos instrumentos presentados en la reunión de expertos para detectar la discapacidad a temprana edad. El propósito del pilotaje fue evaluar la idoneidad y la efectividad de los instrumentos en el contexto Nicaragüense.

Previo al pilotaje, veintidós trabajadores de RBC recibieron capacitación del CIR para el manejo de los instrumentos- "Las Diez Preguntas" (Durkin, et. al. 1990) y "Edades y Etapas: Un Cuestionario Completado para Padres" (Bricker y Squires, 1988). "Las Diez Preguntas", consideradas culturalmente apropiadas, son preguntas sencillas sobre el desarrollo de los niños para detectar discapacidades serias en las áreas cognitiva, motora, visual, auditiva y neurológica (convulsiones) en niños de 2 a 9 años. El cuestionario "Edades y Etapas" parte de las observaciones de los padres sobre el desarrollo de sus hijos y su comparación con otros niños de su barrio. Este cuestionario permite detectar tempranamente el retraso en el desarrollo y otras discapacidades en niños de 4 a 60 meses de edad y monitorear el progreso del niño(a). Las preguntas son sencillas, ilustradas y basadas en actividades cotidianas de la niñez. Durante la capacitación, los trabajadores de RBC revisaron detenidamente las preguntas y el cuestionario, e hicieron valiosas contribuciones para su adaptación a Nicaragua.

Para administrar las "Diez Preguntas" a padres de familia se escogieron 5 centros de salud de Managua que estaban en capacidad de darle seguimiento a los niños que se detectaran de alto riesgo o con discapacidad. A los padres que llegaban a estos centros de salud para la vacunación o consulta médica de sus niños, se les invitó a participar en la actividad. Para confirmar los resultados de las "10 Preguntas" a los niños y niñas a quienes se les detectaron signos de alerta o discapacidad, se les dió seguimiento en sus hogares administrando a los padres "Edades y Etapas: Un Cuestionario Completado por los padres para Evaluar a los Niños". Al finalizar el pilotaje se realizó una reunión con todo el equipo que participó en la investigación a fin de compartir experiencias y compartir retroalimentación sobre los instrumentos.



Mesas de trabajo durante la Reunión Internacional de Expertos en Detección Temprana de Discapacidades de niños y niñas menores de 6 años, realizada en Managua, Nicaragua.

Una de las conclusiones del estudio piloto fue el interés de los participantes en promover la utilización de estos instrumentos en centros de desarrollo infantil, preescolares. Así mismo, los participantes del Ministerio de Salud manifestaron su interés en incluir las "Diez Preguntas" en los centros de salud como parte de su programa materno infantil. Otro resultado del pilotaje fue la decisión de diseñar e implementar un programa de capacitación para los ministerios y organizaciones en Nicaragua que desean realizar actividades de detección temprana. Los procedimientos que se van a recomendar en la capacitación tendrán su fundamentación en la experiencia adquirida durante el pilotaje de detección temprana y en las recomendaciones de los trabajadores de RBC (Reporte de Estudio Piloto, 2002). La capacitación se llevará a cabo a mediados de año y participarán trabajadores de RBC y otras organizaciones.

ACTIVIDADES EN CENTROAMÉRICA

Talleres "Educando a través del Arte", Septiembre 2001 a Marzo 2002

Evaluación Final Teórico-Práctica del Módulo de Prótesis Transfemoral, 7-18 de Enero de 2002.

Prueba de Campo Investigación "Pie Protésico Shape & Roll", Abril a Junio 2002.

Entrenamiento de Uso de los Instrumentos de "Medición de Resultados de los Servicios ofrecidos a Personas con Discapacidad de Centro América", Abril 2002.

Validación de Instrumento del "Modelo Económico de Servicios Protésicos", Junio 2002, FUNTER, El Salvador

Evaluación Final Teórico-Práctica del Módulo de Prótesis Transfemoral, 24 de Junio al 5 de Julio 2002.

Prueba de Campo de los Instrumentos de "Medición de Resultados de los Servicios Protésicos ofrecidos a Personas con Discapacidad de Centro América", 15 de Julio de 2002 a 14 de Julio de 2004.

Taller de Entrenamiento del Uso del "Sistema CIR de Toma de Medidas", 20-23 de Agosto de 2002.

Reunión de Expertos Internacionales sobre "Detección Temprana de Discapacidades en Niño(as) de 0-6 Años", 30 de Septiembre al 2 de Octubre de 2002.

Capacitación y Pilotaje de Detección Temprana de Discapacidades utilizando los instrumentos "Las Diez Preguntas" y "Edades & Etapas", Octubre y Noviembre de 2002.

1a Reunión del Panel Educativo, Programa de Educación a Distancia del CIR, 13 de Diciembre 2002.

Taller Teórico-Práctico de Prótesis Transfemoral Tipo Isquiocontenido, 17-19 de Diciembre 2002.

Sesión de Entrenamiento a los Investigadores Locales del Programa de "Monitoreo Internacional de los Derechos de las Personas con Discapacidad", 13-18 de Enero 2003.

Evaluación Inicial Teórico-Práctica del Módulo de Prótesis Transradial, 23 al 30 de Enero de 2003

Sesión de Evaluación de la Guía de Investigación del Programa de "Monitoreo Internacional de los Derechos de las Personas con Discapacidad", 4, 5 de Marzo de 2003.

renovando el potencial humano. renovando el potencial humano. renovando el potencial humano.

Centro para la Rehabilitación Internacional

CIR, una organización sin fines de lucro, trabaja en colaboración con el Instituto de Rehabilitación de Chicago (RIC), el Centro de Prótesis y Ortesis de la Universidad Northwestern (NUPOC) y el Departamento de Asuntos de Veteranos del Sistema de Salud de Chicago (VAHCS), para acabar con la muerte, amputaciones y discapacidad causada por las minas terrestres antipersonales. CIR, nació como una división de Médicos en Contra de las Minas (PALM), y opera el RERC con el apoyo del Departamento de Educación de los Estados Unidos (NIDDR). El RERC está desarrollando productos de movilidad de alta calidad y bajo costo, así como también tecnologías de rehabilitación para sobrevivientes de minas antipersonales y personas con discapacidades en general.

El Centro para la Rehabilitación Internacional



Centro para la
Rehabilitación
Internacional

Oficina Regional
Calle El Pedregal y Av. L-E,
Jardines de la Hacienda,
Ciudad Merliot,
Antiguo Cuscatlán.
El Salvador, C.A.



Informe Técnico

Un foro para compartir algo mejor, más barato y más rápido

Hiperplasia verrugosa: Un problema de las cuencas de las prótesis de extremo abierto.

Yeongchi Wu, M.D.

La piel humana sirve como un límite entre el cuerpo y su ambiente circundante. Protege los órganos interiores y es la primera barrera contra los organismos infecciosos. Para el amputado, la piel del miembro residual tiene otra función importante aguantando la tensión mecánica del uso del dispositivo protésico.

La piel consiste en dos capas distintas, la epidermis y la dermis (Fig.1). Bajo estas dos capas hay otra capa de tejido hipodérmico. La dermis es más gruesa que la epidermis y proporciona fuerza y elasticidad limitada a la piel. Contiene tejido conjuntivo, como fibras de colágeno que sostienen glándulas, folículos pilosos, vasos sanguíneos, vasos linfáticos, y nervios. Hay cuatro sub-capas en la epidermis. Sus células más profundas se nutren de fluido extracelular proporcionado debajo de la dermis vascular. En el interior en la mayoría de las capas de la epidermis hay células basales que crecen en las células epidérmicas exteriores.

La capa exterior de epidermis es de células muertas que son planas como sobres llenos de queratina manteniéndose unidos por un material consolidado de un espesor de 15 a 25 capas. Esto hace a la piel dura y elástica.

Bajo condición normal, el tejido con fluido rico en oxígeno desde los vasos sanguíneos a los capilar entre las células de tejido, le proporcionan oxígeno vital y nutrientes, y retornan entonces a los capilares venosos y los vasos linfáticos. La cirugía de la amputación rompe esta circulación normal causando acumulación de fluido del tejido (edema) en el sitio de la amputación.

El edema post-operatorio puede prevenirse por la aplicación apropiada de una compresión gradual más proximal que distal. Esto reduce el fluido que está llegando a través de los capilar arteriales en el tejido donde la circulación se daña.

En el diseño de cuencas de extremo abierto, la compresión ocurre principalmente alrededor del área proximal del miembro residual mientras ningún contacto ocurre en el extremo distal. La constricción proximal causará encogimiento proximal pero dilatando (edema) la porción distal, como muestra la ilustración (Fig. 2).

Normalmente, la capa de la superficie de la piel (células muertas con queratina) está constantemente renovándose por las acciones naturales como la fricción de la ropa o el lavado. Si la queratina no se renueva bajo ciertas condiciones, por ejemplo, dentro de un yeso de fractura o una cuenca de extremo abierto, esta se acumulará, creciendo más espesor y más espesor. Cuando la queratina se pone más dura, seca y menos flexible, el edema en las áreas circundantes o el peso que soporta durante la marcha podría estirarlo hasta rasgarlo. El rasgado de la capa gruesa de queratina junto con la epidermis subyacente la conducirá a rezumar y sangrar.

Con la humedad aumentada, la infección secundaria instalada y el tejido suave alrededor del muñón, este se pone rojo e inflamado. Esto tiene una hiperqueratosis con apariencia de verruga: hiperplasia

verrugosa (Fig. 3 y 4).

El tratamiento de hiperplasia verrugosa incluye: 1) control de la infección con antibiótico oral y tópico basado en el cultivo y prueba de sensibilidad de la supuración, 2) Ablandando la masa hiperqueratósica con agente queratósico, como ácido salicílico al 6% en crema o base de petróleo, y 3) Aplicando compresión de contacto total envolviendo al miembro residual (usando envoltura rígida intercambiable que se describirá en detalle en un informe técnico futuro). Cuando el edema distal mejore, proporcione una cuenca de contacto total o una prótesis nueva de contacto total.

Consultando con un dermatólogo este aconseja para el tratamiento apropiado para una hiperplasia verrugosa la cual debería incluir:

1. Empape el muñón en una solución Burrough de 1/40 (una tableta de Domeboro en un cuarto de agua) durante 15 minutos dos veces por día.
2. Limpie con gasa estéril.
3. Entonces aplique ácido salicílico al 6% en crema entre 30 y 60 minutos, dos veces por día.
4. Limpie con gasa estéril y aplique Neosporin crema y seque con material estéril, dos veces por día.

De nuevo, la causa primaria de la hiperplasia verrugosa es que falta compresión en el área distal y presión de constricción excesiva en el área proximal del miembro residual en una cuenca de extremo abierto.

Este problema dermatológico raramente se ve en pacientes que han sido equipados con una cuenca de contacto total.

Referencias

Levit, F: Skin problems in amputees, chapter 31, Atlas of limb Prosthetics, C.V. Mosby Co. 1981.

Traducido por Omar Di Santo, Ortoprotesista.

"Informe Técnico" es un foro para la discusión de procedimientos protésicos innovadores, especialmente aquellos que son sencillos, prácticos y accesibles para países de bajos ingresos. Cualquiera que haya experimentado con éxito una solución única para un problema común específico, lo alentamos para que la someta a consideración para ser publicada aquí. Creemos en el principio de "compartir para beneficiar a las personas con discapacidades". Se otorgará el crédito a quien presente la idea original.

Por favor tener las ideas que pueden ser patentadas, protegidas con la patente correspondiente antes de su presentación.

CENTER FOR INTERNATIONAL REHABILITATION
Annual Report to the Department of Defense
#DAMD17-00-1-0711

APPENDIX C

ISPO Workshop Plenary discussion summary

PLENARY DISCUSSION

Upgrading Courses (Raab, Le Borgne, Trebbin & Karim, Casanova)

Chairman: Harold Shangali

Rapporteur: Sandra Sexton

Presentations regarding the modular upgrading of unqualified experienced field workers in four international locations prompted an enthusiastic delegate response. Initially a number of points of clarification were sought from those presenters offering distance learning courses with electronic resources. These focussed on the ways in which examination and assessment were undertaken. The question of security of on-line student assessment and examination was addressed and it became clear that students received local supervision during these sessions and that the course leaders visit the students in their own country to verify that coursework projects, such as cast modification, are adequately completed. It was intimated that ISPO recognition will be sought for both distance learning programmes and that the ISPO Guidelines are useful in setting standards for distance learning courses. Additionally, communication and collaboration with ISPO had proved to be useful.

The distance learning course at UDB is due to be delivered in two months time. This course is intended to run for a limited but definite period of time with the aim of upgrading existing field workers who are without formal training.

In contrast to this, the distance learning course offered by CIR is intended to be available indefinitely and has been running for some time. Regular on site spot checks by the course leaders were a method of verification of the continuing quality of clinical work performed by the graduate field worker. It is intended by CIR that the course will be offered to other countries in the future.

Both presenters describing distance learning courses highlighted the need for extensive resource allocation in terms of staff time and course materials, which were considered to be essential in ensuring course provision.

Discussion surrounding the two modular courses operating in the field followed. The modular course at Vietcot, offered with student residency, was thought to produce field workers with skills which matched the local need of the population and the modular style of course delivery was not thought to produce a poorer quality of student.

A specific point of clarification was made with regard to the assessment of the spinal module at Vietcot and it was confirmed that an examination of the cast rather than the fit of the device was the basis of assessment. Psychological assessment of the patient was carried out during the course itself. Problems of the sustainability of courses in non-industrial countries were discussed and illustrated by the experiences of the ICRC in creating in-house course provision. Despite initial local agreement about the location of students undertaking the course, changes had been made in moving students from the agreed dispersed areas to a central workplace and thus the centralisation of equipment was made necessary. Further to these difficulties the issue of a promised but undelivered salary and career structure was raised. Discussions with local ministers are ongoing in trying to solve these difficulties.

There was strong comment that a high quality of modern modular students was related to stringent selection criteria and so modular training is not for everyone. Students on modular courses are expected to undertake a high level of self study.

CENTER FOR INTERNATIONAL REHABILITATION
Annual Report to the Department of Defense
#DAMD17-00-1-0711

APPENDIX D

Gradina Prosthetic Center MOU
MOU with Ministry of Martyrs and Disabled (MMD)
Action Plan for Ministry of Martyrs and Disabled

**MEMORANDUM OF UNDERSTANDING
FOR
COOPERATION IN SUPPORT OF REHABILITATION SERVICES FOR THE
DISABLED POPULATION OF BOSNIA AND HERZEGOVINA
THE CENTER FOR INTERNATIONAL REHABILITATION
AND
THE UNIVERSITY CLINICAL CENTER, DEPARTMENT OF PROSTHETICS AND
ORTHOTICS, TUZLA PROSTHETIC CENTER**

The **Center for International Rehabilitation (CIR)**, a Chicago-based non-governmental organization whose mission is to help people with disabilities in developing countries reach their full potential by (i) focusing U.S. research attention on their unique needs and (ii) improving services and outcomes to enhance the quality of their lives;

University Clinical Center, Department of Prosthetics and Orthotics, Tuzla Prosthetic Center, Bosnia and Herzegovina (Tuzla Prosthetic Center), a Bosnian organization committed to providing comprehensive, integrated rehabilitation services to the disabled population of Bosnia and Herzegovina;

Whereas, in fulfilling their commitment to support people with disabilities in the Balkan region;

Have reached the following understanding:

PART I: OBJECTIVE AND SCOPE OF THE AGREEMENT

The objective of this Memorandum is to establish a framework for the relationship between the CIR and Tuzla Prosthetic Center for the implementation of a collaborative plan of action in developing rehabilitation programs, and policies necessary to insure full equality of opportunity for people with disabilities in the Bosnian region.

PART II: ESTABLISHMENT OF THE JOINT INITIATIVE

The Parties will develop a common work plan to:

- a) Establish a mechanism to implement in the Balkans region programs currently being developed under the auspices of the CIR, including conferences, workshops and continuing education for prosthetists and other rehabilitation professionals
- b) Establish a regional office for the CIR to coordinate these activities, including office space and associated amenities (electrical power, water, bathroom, janitorial maintenance)
- c) Conduct conferences and workshops at the Tuzla Prosthetic Center, including provision of technical assistance, logistical coordination, access to space, and access to audio/visual equipment as needed and available

PART III: OBLIGATIONS AND RESPONSIBILITIES OF THE CIR

- a) The CIR will coordinate conferences and workshops at Tuzla Prosthetic Center and will provide technical expertise for this purpose. The CIR will give Tuzla Prosthetic Center ample notification of conference and workshop scheduling to ensure scheduling is convenient for all parties
- b) The CIR will provide funding to cover expenses associated with conferences and workshops, excluding those stated in Part IV, section b)
- c) The CIR will enroll a specified number of Tuzla Prosthetic Center technicians in CIR educational programs in prosthetics and orthotics, and will provide technical staff to lead this instruction
- d) The CIR will contribute funding in the amount of \$300 per month plus travel expenses, as approved by the CIR in advance, to support the use of one prosthetic technician from Tuzla Prosthetic Center to act as assistant instructor for CIR educational programs

PART IV: OBLIGATIONS AND RESPONSIBILITIES OF TUZLA PROSTHETIC CENTER

- a) Tuzla Prosthetic Center will provide office space for CIR staff to coordinate regional activities. Use of the space includes associated amenities (power, water, bathroom, janitorial maintenance)
- b) Tuzla Prosthetic Center will provide CIR with access to space at the prosthetic center for use in conferences and workshops, and will provide access to audio-visual equipment as needed and available
- c) Tuzla Prosthetic Center will provide one prosthetic technician to act as assistant instructor for CIR educational programs. Time commitment shall not exceed 2 hours per day for activities in Tuzla Prosthetic Center and one 2 day trip per month to other centers enrolled in CIR educational programs.

PART V: GENERAL PROVISIONS

- a) Each Party will appoint a liaison officer who will serve as its designated representative in regard to the implementation and management of this Agreement
- b) The liaison officer for the Center for International Rehabilitation is Mersiha Idrizovic, Balkan Regional Administrator, Center for International Rehabilitation, email: midrizovic@cirnetwork.org, telephone: +387 (35) 288161
- c) The liaison officer for Tuzla Prosthetic Center is Dr. Nusret Osmanović, UNIVERZITETSKO KLINIČKI CENTAR TUZLA, Trnovac bb., 75000 Tuzla, telephone: +387 35 231154.
- d) Each Party may change its liaison officer at any time by providing written notice thereof to the other Party.
- e) This Agreement shall run for an indefinite term, and will enter into force when the signatures of the authorized representatives of the Parties are affixed below. Any differences in the interpretation or application of this MOU will be resolved by common agreement of the Parties. Either Party, upon 90 days advanced written notice to the other Party, may terminate this Agreement.

- f) This Agreement may be modified or amended by subsequent agreement of the Parties, providing that such modifications and amendments are in writing, executed by the officials authorized to do so, dated, and affixed to this Agreement.
- g) As a result of this agreement the parties may be furnished or may otherwise have access to information, which may be viewed as confidential or proprietary in nature. Both during and after this agreement, the parties agree that this information will not be disclosed to a third party or used for the exclusive benefit of either of the parties.
- h) All publications in scholarly journals that arise from joint activities shall appropriately recognize the contributions of both parties. CIR will retain intellectual property rights to any programs, materials and products developed in connection with the activities contemplated hereby.

In witness whereof, the undersigned, being duly authorized to that effect, sign this Agreement in Tuzla Prosthetic Center, Bosnia and Herzegovina on the _____ in two originals, Bosnian and English versions. In case of a contradiction, the English version shall prevail.

On behalf of the Center for International Rehabilitation:



 Doug Pyle
 Vice President and Chief Operating Officer
 Center for International Rehabilitation

On behalf of Tuzla Prosthetic Center, as department of University Clinical Center:



 Dr. Uzeir Duraković
 Manager
 Broj: 18/03

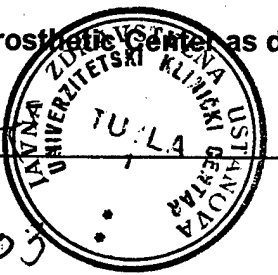

SPORAZUMNI MEMORANDUM
O
SARADNJI U PODRŠCI REHABILITACIONIH USLUGA ZA
ONESPOSOBLJENE OSOBE U BOSNI I HERCEGOVINI

CENTAR ZA INTERNACIONALNU REHABILITACIJU
I
PROTETIČKI CENTAR U TUZLI

Centar za međunarodnu rehabilitaciju (CIR), nevladina organizacija sa sjedištem u Čikagu čija je misija da pomogne ljudima sa onesposobljenjem u zemljama u razvoju da postignu svoj puni potencijal i to (i) fokusirajući istraživačku pažnju SAD-a na njihove jedinstvene potrebe i (ii) poboljšavajući usluge i njihove rezultate u cilju poboljšanja kvalitete života.

I

Univerzitetско klinički centar, Odjel za protetiku i ortotiku, Protetički centar u Tuzli, Bosna i Hercegovina (Protetički centar u Tuzli) bosanska organizacija koja se bavi pružanjem usluga potpune, integrirane rehabilitacije onesposobljenim osobama u Bosni i Hercegovini.

Su, ispunjavajući obavezu da podrže onesposobljene osobe u balkanskoj regiji,

Postigli slijedeći sporazum:

I DIO: CILJ I OPSEG SPORAZUMA

Cilj ovog memoranduma je da uspostavi okvir odnosa CIR-a i Protetičkog centra u Tuzli u implementaciji kolaborativnog plana djelovanja u razvoju rehabilitacionih programa i pravila koja su neophodna kako bi se osigurala potpuno jednaka mogućnost pristupa svim osobama sa onesposobljenjem u bosanskoj regiji.

II DIO: USPOSTAVA ZAJEDNIČKE INICIJATIVE

Strane će razviti zajednički plan rada u cilju:

- a) uspostavljanja na Balkanu mehanizma implementacije programa koji se trenutno razvijaju pod pokroviteljstvom CIR-a, uključujući konferencije, radionice i kontinuiranu edukaciju protetičara i drugih rehabilitacijskih stručnjaka;
- b) uspostavljanja regionalnog ureda CIR-a, koji će koordinirati ove aktivnosti, uključujući kancelarijski prostor i potrebne priključke (struja, voda, toalet, čišćenje i domar);
- c) vođenja konferencija i radionica u tuzlanskom protetičkom centru, uključujući obezbjeđivanje tehničke pomoći, logističke koordinacije, pristupa radnom prostoru i pristupa audio/video opremi u slučaju potrebe.

III DIO: OBAVEZE I DUŽNOSTI CIR-a

- a) CIR će koordinirati konferencije i radionice u Protetičkom centru u Tuzli i obezbijediti tehničke stručnjake za ovu svrhu. CIR će Protetičkom centru u Tuzli davati opširne obavijesti o rasporedu konferencija i rada radionica kako bi se osigurao raspored koji odgovara svima;
- b) CIR će obezbijediti sredstva za pokrivanje troškova konferencija i radionica, (isključujući one navedene u Dijelu IV, tačka d);
- c) CIR će primiti određeni broj tuzlanskih tehničara u CIR-ove edukacione programe protetike i ortotike, kao i obezbijediti tehničko osoblje koje će davati instrukcije;
- d) CIR će obezbijediti fond od \$300 mjesečno uz putne troškove za jednog protetičara-tehničara iz Protetičkog centra u Tuzli, koji će biti asistent CIR-ovom instrukturu u edukacijskim programima.

IV DIO: OBAVEZE I DUŽNOSTI PROTETIČKOG CENTRA U TUZLI

- a) Protetički centar u Tuzli će obezbijediti kancelarijski prostor za osoblje CIR-a koje će koordinirati regionalne aktivnosti. Korištenje prostora uključuje i potrebne priključke (struja, voda, toalet, čišćenje, domar);
- b) Protetički centar u Tuzli će CIR-u obezbijediti pristup prostoru protetičkog centra kao i korištenje tog prostora za konferencije i radionice; takođe, obezbijedit će pristup audio/video opremi kada je to potrebno;
- c) Protetički centar u Tuzli će obezbijediti jednog tehničara-protetičara koji će biti asistent CIR-ovom instrukturu u edukacionim programima. Njegovo radno vrijeme neće prelaziti 2 sata dnevno za aktivnosti u Protetičkom centru u Tuzli i i jednog dvodnevnog putovanja mjesečno u druge centre uključene u CIR-ove programe.

V DIO: OPŠTE ODREDNICE

- a) I jedna i druga strana će odrediti osobu za međusobne odnose, koja će ujedno biti i njen predstavnik u implementaciji i menadžmentu ovog Sporazuma;
 - b) Osoba za međusobne odnose od strane Centra za internacionalnu rehabilitaciju je Mersiha Idrizovic, Regionalni administrator za Balkan, Centar za međunarodnu rehabilitaciju, email: midrizovic@cimnetwork.org, telefon: +387 (35) 288161
 - c) Osoba za međusobne odnose od strane Protetičkog centra u Tuzli je Dr. Nusret Osmanović, UNIVERZITETSKO KLINIČKI CENTAR TUZLA, Trnovac bb., 75000 Tuzla, telefon: +387 35 231154.
- b) Obje strane imaju pravo promijeniti osobu za međusobne odnose u bilo koje vrijeme uz pismenu obavijest drugoj strani;
 - c) Period važenja ovog Sporazuma je neodređen, a stupa na snagu nakon što ga potpišu ovlašteni predstavnici obje strane. Sve razlike u interpretaciji ili primjeni ovog Sporazuma bit će riješene zajedničkim dogovorom obje strane. Bilo koja strana može okončati ovaj Sporazum uz pismenu obavijest drugoj strani koja mora biti predana 90 dana unaprijed;

- d) Ovaj Sporazum može biti modificiran ili mu se mogu naknadno dodati amandmani uz pristanak obje strane, s tim da takve modifikacije ili amandmani budu u pismenoj formi, urađeni od strane za to ovlaštenih službenika, sa tačnim datumom i dodani ovom Sporazumu;
- e) Kao rezultat ovog Sporazuma stranama mogu biti date ili na neki drugi način mogu imati pristup povjerljivim informacijama. Ovim Sporazumom obje strane se slažu da ni za vrijeme trajanja ovog sporazuma ni nakon toga takve informacije neće biti iznesene trećoj strani ili korištene u cilju vlastite koristi bilo koje strane;
- f) Sve publikacije u akademskim magazinima koje proiziđu iz zajedničkih aktivnosti moraju odavati priznanje doprinosu obje strana. CIR zadržava intelektualna vlasnička prava nad svim programima, materijalima i proizvodima stvorenim u vezi sa gore navedenim i razmatranim aktivnostima.

Dole potpisani, ovlašteni za to, potpisuju ovaj Sporazum u Protetičkom centru u Tuzli, u Bosni i Hercegovini, dana 15. 01. 2003 u dva originala, od kojih je jedan na bosanskom a jedan na engleskom jeziku. U slučaju kontradikcije, engleska verzija ima prednost nad bosanskom.

U ime Centra za internacionalnu rehabilitaciju (CIR)

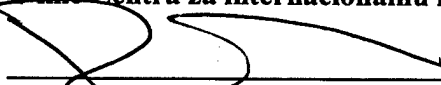

Doug Pyle
Vice President and Chief Operating Officer
Center for International Rehabilitation

U ime Protetičkog centra u Tuzli kao dijela Kliničko univerzitetskog centra

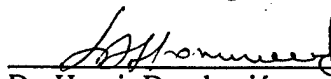

Dr. Huzeir Duraković
Manager

Broj: 1-2/03



**MEMORANDUM OF UNDERSTANDING
FOR
COOPERATION IN SUPPORT OF REHABILITATION SERVICES FOR THE PEOPLE
OF AFGHANISTAN**

THE CENTER FOR INTERNATIONAL REHABILITATION

AND

**THE MINISTRY OF MARTYRS AND DISABLED
GOVERNMENT OF AFGHANISTAN**

The Center for International Rehabilitation ("CIR"), a Chicago-based non-governmental organization whose mission is to help people with disabilities in developing countries reach their full potential; and

The Government of Afghanistan, Ministry of Martyrs and Disabled ("MMD");

Whereas, in fulfilling their commitment to support people with disabilities in Afghanistan;

Have reached the following understanding:

PART I: OBJECTIVE AND SCOPE OF THE AGREEMENT

The objective of this Memorandum of Understanding ("MOU") is to establish a framework for the relationship between the CIR and MMD ("the Parties") for the implementation of a collaborative plan of action in developing rehabilitation programs and policies to support assistance to people with disabilities and the rebuilding of Afghanistan.

PART II: ESTABLISHMENT OF THE JOINT INITIATIVE

The Parties will develop a common work plan to:

- a) Develop the technical and administrative abilities and capacity of the MMD to effectively implement programs assisting people with disabilities in Afghanistan, and coordinate these programs with other government ministries and international nongovernmental organizations.
- b) Assist in the coordination and administration of field trials of a specially-designed wheelchair suitable for use in Afghanistan and other mine affected, post-conflict terrain.
- c) Assist in the development of a proposal for a National Disabilities Needs Assessment and research based project for Afghanistan.
- d) Identify additional areas of need with regard to people with disabilities and develop programs to address these needs using the capabilities of each of the Parties and in coordination with other government ministries and international nongovernmental organizations.
- e) Collaborate to identify and secure financial and technical resources to advance joint activities.

PART III: OBLIGATIONS AND RESPONSIBILITIES OF THE CIR

- a) The CIR will commit resources as available, including salary support and technical expertise, for the development of technical and administrative capacity at the MMD.
- b) The CIR will commit financial resources and technical expertise for the development and field-testing of a specially-designed wheelchair for Afghanistan.
- c) The CIR will commit technical expertise for the development of additional programs assisting people with disabilities in Afghanistan and collaborate with the MMD to secure financial support for these programs.

PART IV: OBLIGATIONS AND RESPONSIBILITIES OF MMD

- a) MMD will identify, hire, and supervise the work of personnel who will provide administrative and technical assistance to the MMD and to the CIR as joint activities require.
- b) MMD will provide logistical assistance to CIR for the implementation of the joint activities, including assisting with travel arrangements, governmental regulations and communications, and other administrative requirements for the implementation of joint activities.
- c) MMD will maintain monthly communications with CIR regarding its current activities and planned activities, and opportunities for collaboration.
- d) MMD will maintain communications with governmental ministries and international nongovernmental organizations and on a regular basis provide CIR with information on governmental programs and other activity that impacts joint activities of the MMD and CIR.
- e) MMD will collaborate with the CIR to secure financial support for additional programs assisting people with disabilities in Afghanistan.

PART V: GENERAL PROVISIONS

- a) Each Party will appoint a liaison officer who will serve as its designated representative in regard to the implementation and management of this MOU.
- b) The liaison officer for the Center for International Rehabilitation is Nikola Prvulov, Field Operations Manager. His address, telephone number, fax number, and e-mail address are as follows: 351 E., Huron, 2nd Floor Annex, Chicago, Illinois, 60611, phone (312) 926-0021, fax (312) 926-7662, email: nprvulov@cirnetwork.org.
- c) The liaison officer for the Ministry of Martyrs and Disabled is Naquibulla Hamdard, Interministerial Advisor. His address, telephone number, and e-mail address are as follows: Ministry of Martyrs and Disabled, Old Macroryan, Kabul, Afghanistan, phone ++093-20-230-0369, email: ministry@disability-afghanistan.org.
- d) Each Party may change its liaison officer at any time by providing written notice thereof to the other Party.

- e) This MOU shall run for an indefinite term, and will enter into force when the signatures of the authorized representatives of the Parties are affixed below. Any differences in the interpretation or application of this MOU will be resolved by common agreement of the Parties. Either Party, upon 90 days advanced written notice to the other Party, may terminate this MOU.
- f) This MOU may be modified or amended by subsequent agreement of the Parties, providing that such modifications and amendments are in writing, executed by the officials authorized to do so, dated, and affixed to this MOU.
- g) As a result of this agreement the parties may be furnished or may otherwise have access to information, which may be viewed as confidential or proprietary in nature. Both during and after this agreement, the parties agree that this information will not be disclosed to a third party or used for the exclusive benefit of either of the parties.
- h) All publications in scholarly journals that arise from joint activities shall appropriately recognize the contributions of both parties. CIR will retain intellectual property rights to any programs, materials and products developed in connection with the activities contemplated hereby.

In witness whereof, the undersigned, being duly authorized to that effect, sign this MOU in see below on the see below.

On behalf of the Center for International Rehabilitation:

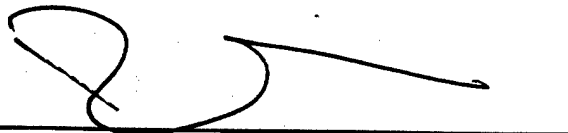

CHICAGO, ILLINOIS
MAY 1, 2003

Doug Pyle
Vice President and Chief Operating Officer
Center for International Rehabilitation

On behalf of the Ministry of Martyrs and Disabled:

Minister Abdullah Wardak
Ministry of Martyrs and Disabled
Government of Afghanistan

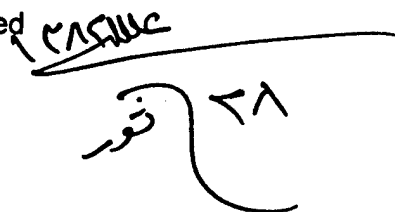

Action Plan

The Center for International Rehabilitation (CIR) & The Ministry of Martyrs and Disabled (MMD)

Project Description

I. Background

This Agreement represents an action plan as mandated by the Memorandum of Understanding ("MOU") between the Center for International Rehabilitation ("CIR") and the National Ministry of Martyrs and Disabled ("MMD"), signed by the CIR and MMD ("the Parties") on 1st May 2003. This Agreement requires an executed MOU to be effective.

The objective of the Agreement is to establish a collaborative plan of action between the CIR and MMD to implement a collaborative plan of action in developing rehabilitation programs and policies to support assistance to people with disabilities and the rebuilding of Afghanistan.

II. Term

The following agreement covers a 6 month period beginning on April 1, 2003. At the end of the Initial Term, the Parties may by mutual agreement, and pursuant to a written amendment to this Agreement, extend the term for an agreed period of time. The terms of this Agreement shall govern any such extension of the Initial Term, unless otherwise agreed by the Parties in writing.

III. Plan Contents

By signing below, the CIR and MMD do hereby agree on a common action plan as follows for achieving the objectives established in the MOU:

Work Plan

1. The CIR shall provide funds, not to exceed \$16,500 within the Initial Term as defined in "Cost Reimbursement" below, to the MMD to recruit and hire two full time staff members to be located at the MMD. The responsibilities and qualifications of these staff members are detailed under "Annex I" of this Agreement. The hiring of these staff positions requires the prior review and approval of the MMD and CIR.
2. The MMD shall participate in joint activities with the CIR as defined by the following responsibilities of the MMD:
 - a. Coordinate the Wheelchair Project with Afghan Amputee Bicyclists for Rehabilitation and Recreation (AABRAR) as defined by the scope of work outlined in Annex II.
 - b. Develop a MMD Policy for People with Disabilities and provide the CIR with periodic reports on the progress of the development of this policy.

- c. Identify funding opportunities and collaborate with the CIR to develop proposals for new programs for the benefit of people with disabilities.
 - d. Assist the CIR in the promotion of this program with the Ministry of Health ("MOH") and facilitate communications and collaboration between the CIR, MMD and MOH, including discussions on a proposed National Institute for Prosthetics and Orthotics.
 - e. Provide logistical assistance to CIR for the implementation of the joint activities, including assisting with travel arrangements, governmental regulations and communications, and other administrative requirements for the implementation of joint activities.
3. The MMD shall provide CIR with monthly reports on the progress of the areas of collaboration defined above. The MMD shall also provide CIR with completed timesheet forms (please see "Annex III") for the month.
 4. In addition to the above subject areas the MMD will monitor the progress of and track the following. The CIR reserves the right to request updates, reports and otherwise information on the following subject areas from the MMD on a periodic basis:
 - War wounded data base.
 - Vocation training and employment for people with disabilities.
 - Accessibility for people with disabilities.
 - Discrimination towards people with disabilities especially women and children.
 - Gender issues.
 - Prosthetic and Orthotic needs.
 - Education for people with disabilities.
 - Mental Health.
 - Children and pediatric needs.

IV. General Provisions

1. Each Party will appoint a liaison officer who will serve as its designated representative in regard to the implementation and management of this Action Plan.

a) The liaison officer for the Center for International Rehabilitation is Nikola Prvulov, Field Operations Manager. His address, telephone number, fax number, and e-mail address are as follows: 351 E., Huron, 2nd Floor Annex, Chicago, Illinois, 60611, phone (312) 926-0021, fax (312) 926-7662, email: nprvulov@cirnetwork.org.

b) The liaison officer for the Ministry of Martyrs and Disabled is Naquibulla Hamdard, Interministerial Advisor. His address, telephone number, and e-mail address are as follows: Ministry of Martyrs and Disabled, Old Macroryan, Kabul, Afghanistan, phone ++093-20-230-0369, email: ministry@disability-afghanistan.org, disability-afghanistan@yahoo.co.uk

2. Cost Reimbursement: The CIR shall provide funds to the MMD not to exceed \$16,500 as reimbursement for the provision of CIR/MMD staff time for purposes of implementation of this Action Plan. Payment will be made in installments of \$2,750.00 each month, \$1,400.00 for the Interministerial Advisor and \$1,350.00 for the Gender

Awareness Advisor, executed upon completion of the above mentioned items as determined by both Parties.

3. Intellectual Property: CIR will own all intellectual property rights, including all copyright, in and to any and all programs, materials, products, content, technology, or other works developed in connection with the activities contemplated hereby. Such ownership will be on a worldwide basis, without limitation, and will extend to any medium (now known or hereafter invented) in perpetuity. By signing below, the MMD agrees that such agreement will be governed by and interpreted according to the federal and state laws of the United States of America. The MMD further agrees that works developed under such agreement shall be "works made for hire" under the United States Copyright Act and if such works are not considered to be "works made for hire" the MMD shall give, transfer and assign to CIR all right, title and interest now or hereafter arising in and to such works.

Before, during and after such agreement among CIR and the MMD, use of or disclosure of confidential or proprietary information to a third party is prohibited.

4. Applicable Law: This Action Plan shall be construed and interpreted pursuant to the internal laws of the State of Illinois, without giving effect to any conflicts of laws or principle of such State.

5. Changes: changes to this Agreement requires the written concurrence of both parties as represented by the individuals identified below.

6. Termination: Either Party, upon 30 days advanced written notice to the other Party, may terminate this Agreement with or without cause.

In witness whereof, the undersigned, being duly authorized to that effect, sign this Agreement in Kabul, Afghanistan on the 18 May 2003 in two original English versions.

On behalf of the Center for International Rehabilitation:



Doug Pyle
COO and Vice President
Center for International Rehabilitation

MAY 12, 2003
CHICAGO, IL

On behalf of the Ministry of Martyrs and Disabled

1515 Sule
Minister Abdullah Wardak 
Minister of Martyrs and Disabled Government of Afghanistan

ANNEX I

Scope of Work

SCOPE OF WORK FOR NATIONAL INTER-MINISTERIAL ADVISOR

This position will provide general operational support to the Minister in all MMD's activities, including national disability policy development at ministry and coordination between partners and donors. The post holder will primarily report to the Minister of Martyrs and Disabled and will send monthly activity summaries to the CIR.

Key Responsibilities:

- Provide general advice and counsel to the Minister, as requested in the areas below.
- Support the developing of the Office of the Minister at MMD, that includes:
 - Pursue protocol and related issues.
 - Supervision of the staff of the Minister
 - Provide strategic coordination support to the Minister for Martyrs and Disabled, including coordinating with officials of the Ministry to ensure that the Ministers policy and operation directives are executed while assist in implementing reporting and management mechanisms
 - Attending meetings with or on behalf of the Minister, taking notes and minutes, reporting to all involved parties
 - Planning trips and travel
- Liaise with stakeholders to improve advocacy, programme integration and to enable synergies with international community and NGO-based disability program. Develop institutional mechanisms to support this process.
- Develop a mechanism for donor relations and support the Minister in fundraising.
- Assists the National Disability Commission and represents the Minister in the legislative development process as necessary.
- Supervise the development of a "National Disability Strategy" in conjunction with members of the Ministry, INGO's and Civil Society.
- Plan and implement a mechanism for assessing disability services and providing ongoing feedback to the donor and implementation communities on improvement of services.
- Any other tasks as assigned by the Minister for Martyrs and Disabled.

Qualifications:

- University graduate in management or equivalent.
- A minimum of 7 years experience in management within INGO's or UN agencies, preferably in a field related to rehabilitation or development.
- Knowledge of community awareness and advocacy.
- Advance knowledge of written and spoken English and a demonstrated written ability.
- A good command of Dari and Pashtu languages .
- Sound secretarial knowledge and experience.

- Full knowledge of computer MS word and MS excel.

SCOPE OF WORK FOR NATIONAL GENDER PARTICIPATION ADVISOR

The National Gender Participation Advisor position is a Senior Advisor position with Ministry of Martyrs and Disabled. This position will ensure that disabled men and women have equal access to different resources of the MMD and that they have equal voice in decision the making process and its production. The Gender Participation advisor will report directly to the Minister of Martyrs and Disabled with technical reporting to CDAP Senior Technical Advisor. The post holder will perform the following activities closely supervised by STA/CDAP.

Key Responsibilities:

- To review MMD level policies from a gender perspective in line with the United Nations' CDAP enhanced commitments to Women and Gender Strategy.
- To assess and make recommendations about the gender aspects of the MMD program in Afghanistan and participating in missions as a resource person when necessary. This is supported by STA at CDAP.
- To support the process of developing a Gender Action plan at the MMD central level as well as regional offices.
- To ensure that women's voices are heard, and women's special needs are fully addressed and incorporated into MMD operation, by assisting to hire and train female assessors and/or participating in assessments of disability.
- To participate in monitoring and evaluating gender policies at all levels and take part in aspects of disability gender research.
- To assist HR at MMD and other ministries with strategies to recruit, hire and keep qualified disabled female national staff.
- To help create and support a gender balanced Gender Working Groups at the MMD level, with representatives from regions throughout Afghanistan.
- To assist the CIR with coordination of activities related to people with disabilities.

Qualifications:

- A university degree in social sciences or other relevant subject.
- At least 5 years relevant experience in the UN System or INGO's.
- Ability and willingness to travel throughout Afghanistan (security permitting).
- Proven ability to work in a multi-cultural team environment.
- Experience using participatory community development approaches, and managing projects focused on women and gender equity.
- Track record of working well under pressure and in an emergency environment.
- Excellent communication and interpersonal skills, at local level with communities but also in larger international setting.
- Computer proficiency (MS word Excl).

Fluency in written and spoken in both English and Dari Language.

ANNEX II

Outline of coordination with AABRAR

1. Hold frequent meetings with AABRAR in order to monitor their progress with the Wheelchair Project.
2. In the MMD monthly reports to the CIR report on the monthly progress of AABRAR regarding the Wheelchair Project.
3. Assist AABRAR in identifying an assembly/repair facility, for example, bicycle shop or similar.
4. Assist AABRAR and the Lahore factory in the delivery of wheelchair parts with potential issues regarding customs clearance.
5. Assist AABRAR in the identification and follow-up of potential wheelchair users.

CENTER FOR INTERNATIONAL REHABILITATION
Annual Report to the Department of Defense
#DAMD17-00-1-0711

APPENDIX E

IDRM Research Guide
Regional Training Workshops materials
IDRM Website pages



International Disability Rights Monitor

International Disability Rights Monitor 2003: The Silent Crisis V 2.7

About this Research Guide

This research guide is a manual for IDRM researchers, regional coordinators and editors to facilitate the production of a readable, informative, and useful report on the rights and conditions of persons with disabilities around the world. The guide includes the IDRM questionnaire, practical suggestions on conducting research, instructions for submission of data and reports, and a style manual.

The manual is a supplement to, not a replacement for, the in-person training provided by IDRM.



QUESTIONS TO GUIDE RESEARCH:

5

A note on question format:

8

I. IDENTIFYING THE DISABILITY COMMUNITY

II. DISABILITY RIGHTS

ERROR! BOOKMARK NOT DEFINED.

III. INCLUSION AND ACCESSIBILITY

ERROR! BOOKMARK NOT DEFINED.

IV. DISABILITY ACTION AND AWARENESS

ERROR! BOOKMARK NOT DEFINED.

PANEL QUESTIONS

ERROR! BOOKMARK NOT DEFINED.

CONDUCTING A PANEL DISCUSSION

43

STYLE GUIDE

48

SUBMITTING THE REPORT

49



CENTER FOR INTERNATIONAL
Rehabilitation

INTERNATIONAL DISABILITY RIGHTS MONITOR: 2003

**International Disability Rights Monitor
Research Guide**

QUESTIONS

Copyright 2001 Center for International Rehabilitation, All rights reserved

Page 3 of 49



QUESTIONS TO GUIDE RESEARCH:

Introduction

The following questions are designed to guide the research for country reports included in the first International Disability Rights Monitor Report being compiled in 2003. The answers to these questions should contain the essential data to be included in each country report.

In writing the country reports, the researcher should keep in mind that the purpose of International Disability Rights Monitor is to document, on a country by country basis, the progress, problems and barriers experienced by people with disabilities around the world. Seeking an objective appraisal that incorporates both positive and negative aspects will strengthen International Disability Rights Monitor as an instrument for change. The report should enable readers to identify both what a country has done to move the world closer to achieving equal treatment for people with disabilities and what barriers hinder progress.

Please remember that this questionnaire is designed to guide research. While the responses to closed-end questions should be entered into the database and included in the documents you return to CIR, the country report you submit should be descriptive. Please refer to the sample country report as a guide for style and format. All raw data from interviews, including background information on respondents, notes from interviews, and supplementary documents should be copied and forwarded to the regional coordinator along with the submitted report. We ask that researchers approach the project with the understanding that a surplus of information is better than a dearth of information. We will work together to edit your country report down to size.

While final research reports are due in October 2003, there will be some opportunity for essential updates of information until January 2004.

The questions below encompass three themes: the rights of persons with disabilities, the problems, progress and barriers experienced by persons with disabilities, and the state of disability advocacy. Questions regarding the existing economic, political and environmental conditions are included to provide an overall picture of the circumstances of persons with disabilities in each country. Questions regarding rights generally correspond with the recommendations of the Expert Group Meeting on the Comprehensive and Integral International Convention to Promote and Protect the Rights and Dignity of Persons with Disabilities held in Mexico City 11-14 June 2002.



CENTER FOR INTERNATIONAL
Rehabilitation

INTERNATIONAL DISABILITY RIGHTS MONITOR: 2003

While the questions are detailed, researchers are not limited to the questions in this questionnaire. Instead, researchers are encouraged to engage in dialogue with respondents. This method of open-ended interviewing facilitates comparison of data yet permits the interviewer to obtain information on unanticipated topics.

Research Standards and Methods

In order for the IDRM to be successful, the annual report and database must be credible sources of information. Thus, the research used to gather the data and create the reports must be based on thorough, standard research methodology. The following guidelines must be followed in order to ensure the necessary standards:

- **Thorough footnoting is critical. All sources of all information presented in the report and questionnaire must be documented. Keep copies of all data sources, notes from all interviews, and your activity log. Keep originals, send copies to IDRM.**
- **Maintain your records in a secure location. Only IDRM personnel should have access to your notes from interviews and panel discussions.**
- **File all materials in a logical, easily accessible manner, so that facts can be verified upon request.**
- **All information should be cross-checked and verified. The ideal model to follow is to have at least three independent sources for each fact you present. Corroboration is critical for the IDRM report to be credible and useful. You must cite your sources in both the database and the country report.**
- **Use primary materials first when answering the questionnaire. Use interviews to verify data, fill in gaps, and find out additional information.**
- **Please identify respondents by name and, if appropriate, by title, keeping in mind the guidelines relating to confidentiality.**
- **Be specific about the time period covered by responses, whether calendar year, fiscal year or some other time unit.**
- **Assess the reliability of each and every source of information. Ask what is the original source of the information.**
- **Where appropriate, interview as many people as possible to obtain varied perspectives, particularly on attitudinal questions.**

- Complete the 'confidence scale' for each question that includes one, and provide explanations for the confidence ratings you provide. You may provide unconfirmed information if you judge it important to include, but you must assess its reliability.
- Quotes must be exact. If you are not using a tape recorder, take careful notes. You can read back a passage to the interviewee if you think you might like to use the quote.
- Remain open to unanticipated responses from interviewees. Be flexible and open-minded when gathering and analyzing information.
- Research should be conducted in as professional and objective a manner as possible. The strength of the IDRM report and database relies on the quality of the data gathered, so fact-finding must be thorough and accurate.
- Your safety and that of your sources is of paramount importance. Thoroughly assess any potential safety concerns before deciding to conduct the research. If you have any safety concerns, contact your Research Coordinator immediately.

A note on question format:

Three types of questions are included in the questionnaire; report card questions, general questions, and panel questions. 'Report card' questions are designed to permit cross-national comparison on essential issues. These questions are noted in the body of the questionnaire in bold, and with a special heading. The 'panel questions' are attitudinal or opinion questions that are designed to be answered by participants in panel meetings. Several of these questions only appear in the 'panel question' section at the end of the questionnaire. Some of these attitudinal questions are appropriately addressed to other respondents as well, and are included in the body of the questionnaire. The general questions make up the majority of questions in the questionnaire, and should be straight-forward.

Confidence scales: a confidence scale is included after many questions. Researchers should check off the box that corresponds to their level of confidence that the question's answer is 'correct'. A '1' indicates virtually no confidence, a '10' indicates complete



confidence. A '10' would include undisputable facts, or facts supported by three independent, verifiable and properly cited sources. Please provide additional information when confidence levels are below '7'.

I. IDENTIFYING THE DISABILITY COMMUNITY

This section focuses on those activities that are designed to identify people with a disability.

Report Card Question:

1. *What is the total number of persons with disabilities in your country?*

Confidence scale

2. What percentage of the general population is comprised of people with a disability?

Confidence scale

Indicate the source of this population information

- Population data can be found via the national census bureau, other national statistics offices, health ministries, or other governmental ministries. National libraries often keep updated information of this nature, and governmental websites sometimes maintain this data as well.
 - If officials provide statistics, find out where the data comes from. If the source is UN or World Bank or another international source, ask officials why these data are used.
3. What are the definitions of disability used in epidemiologic or census activities, national policy, official and regulatory documents? Please compare and contrast.
 - If you find different definitions in different policies or official documents, please analyze why these differences exist. For example, is it a problem of outdated ideas about disability? Is it a matter of defining certain populations for inclusion or exclusion from social services?

4. Has there been greater than a 10% change in the number of people with disabilities in your country in the last 5 years?

- yes
 no

Confidence scale

4a. If yes, is it an increase or decrease?

4b. What is your source of information?

4c. Please discuss the reasons for this change

- Possible reasons for a change include but are not limited to: civil conflict, international conflict, disease, or the cessation of such events, increased/improved reporting, aging population, change in reporting methodology, change in definition of disability, social violence (e.g. gangs)
5. Please provide a bibliography of relevant disability related statistics, studies, reports and articles focusing on your country that have been released in the past year.
- This bibliography can be a starting point for people interested in learning more about disability in your country. Electronic materials can be linked to your eventual report.
6. Has any data been gathered on people with disabilities in your country in the last 5 years?
- yes
 no
- 6a. if yes please provide references



6b. if no, when was data last gathered?

Confidence scale

- If there has been more than one disability survey conducted, compare and assess their results and/or methodology

If the answer to question #6 is yes, complete questions 7-10 and include the survey as an appendix to your report.

7. Who was responsible for carrying out the assessment or survey in question 6?

- national government
- UN Agency
- other international agency
- NGO
- consultant
- other, please specify _____

8. Is the survey or assessment finished?

- yes
- no

8a. If no, when will it be completed? _____

9. Are the results of the assessment or survey available to the public?

- yes
- no

- 9a. If no, what reasons are given? _____
10. On a scale of 1-10 please indicate the level of confidence you have in the information contained in this assessment or survey and briefly discuss why.

- This question is appropriately addressed to both the organization or department that conducted the survey and to disability advocates in panel discussion sessions

II. DISABILITY RIGHTS

Human rights are universal and apply to those with and without a disability.

This set of questions focuses on the standards set by the international community, national governments and local authorities. Examples of international covenants, norms and agreements include the United Nations Standard Rules on the Equalization of Opportunities for People with Disabilities, the Universal Declaration of Human Rights, the UN Convention on Economic, Social and Cultural Rights, the UN Convention on the Rights of the Child, the Declaration on the Rights of Disabled Persons and the Principles for the Protection of Persons with Mental Illness.

Please identify respondents by name, if appropriate, and by title.

Report Card Question:

11. *Is there a national law that specifically references and protects of the rights of people with disabilities?*

yes
 no

- 11a. What is the definition of disability under this law?
- 11b. What groups of people are covered under this law?
- Again, contrasting this definition to definitions used in other policies and laws is useful.

12. What is the nature of other policies protecting the rights of people with disabilities?
- constitutional guarantees
 - international or regional covenants
 - national legislation
 - national guideline
 - standard or guideline established by a National Council on Disability
 - social entitlement programs (e.g. income support)
 - judicial protections
 - other, please specify _____

Please include a copy of any legislation or policy statements that are specific to your country with your report

- 12a. If possible please list and discuss some of the factors that led to the adoption of relevant disability protections.

13. If a national law protecting the rights of people with disabilities exists, who must comply with this law?
- Check all that apply
- government actors (Government agencies, Military, etc.)
 - private individuals
 - commercial entities (Corporations)
 - other, please specify _____

Confidence scale

- If there are laws specifically addressing the rights of persons with disabilities, what penalties are provided for failure to comply with the laws? E.g. are there civil or criminal penalties? To what degree are these penalties actually enforced?
- If there are such laws, what is their level of effectiveness? Have the laws made a direct affect on people with



disabilities? Why or why not? Do these laws cover all people with disabilities? Have the laws been fully implemented?

14. Does your country have a law that states that a person with a disability cannot be discriminated against in employment on the basis of his or her disability?
 yes
 no
15. Please review whether your country has signed on to the
- United Nations Standard Rules on the Equalization of Opportunities for People with Disabilities resolution and/or
 - (answer ONLY if you are conducting research in a country of the Americas) OAS Inter-American Convention on the Elimination on all Forms of Discrimination Against Persons with Disabilities
- and whether it is in compliance with all relevant reporting requirements. (Information is available on the CIR website.) If the answer is no to any of these questions, please discuss the reasons.

- What is your analysis of your country's legislation in relation to the United Nations standards? Does it meet or exceed the Standard Rules? How do the national laws relate to the inter-American Convention?

Report Card Question

16. **Has your government issued a statement in support of the creation of a United Nations Convention on the Rights of Persons with Disabilities?**

- yes
 no

- Has your country made any statement about *future* engagement with United Nations Standard Rules on the Equalization of Opportunities for People with Disabilities, or other documents?

- If your country has no reporting or statement on disability, why do you think this is the case?
- How has your country voted in the past on issues involving disability and human rights within parameters of the United Nations?
- Are there any major policy statements on the rights of the disabled, or declared positions on the role of people with disabilities in society?
- What is your assessment of the importance of disability rights in your country's foreign or domestic policy?

17. How many institutions in your country are operating with the specific and exclusive mission of providing long-term (more than one year) housing and care to people with disabilities?

Confidence scale

17a. If possible, for each of the centers listed above, please check off the services provided by these institutions.

Check all that apply

- psychological counseling
- psychiatric counseling
- rehabilitation services
- acute care services
- education/training

17b. If possible, for each of the centers identified list the number of individuals living in these institutions?

Confidence scale

- Do individuals in these institutions or outside them have the right to refuse treatment? Indicate whether any such coerced treatment is done by custom, by law, or by socio-economic constraints such as contingent services.



18. Under what circumstances are persons with disabilities placed in these institutions against their will?
- What criteria or tests are used for determining institutionalization?

Confidence scale

19. Is there a mechanism for reporting incidences of abuse in such institutions?

yes
 no

19a. If yes, please describe _____

20. Is there a mechanism for reporting incidences of death in such institutions?

yes
 no

20a. If yes, please describe _____

21. Are the conditions in these institutions, including incidence of death and abuse, monitored by an outside entity?

yes
 no

Confidence scale

22. Have there been any investigations of the incidence of death and abuse at any of these institutions in your country within the last year?

yes
 no

21a. if yes, please provide additional information

Confidence scale



23. Do one or more organizations or entities in your country keep records of abuse or violence against people with disabilities?
 yes
 no
22a. If yes, please provide the organization's name and contact information

24. Do one or more organizations or entities in your country keep records of discrimination against people with disabilities in the areas of housing, employment, education, transportation?
 yes
 no
23a. If yes, please provide the organization's name and contact information

25. Is there an organization(s) in your country that is specifically dedicated to protecting the human or civil rights of people with disabilities?
➤ What are the laws about guardianship or legal representation? Can guardianship or legal representation be imposed over a person's objection? Does guardianship/legal representation take away the person's right to assert her or his own legal rights?
➤ What strategies are most effective for addressing human rights violations or discrimination against persons with disabilities?
➤ Examples might include: civil lawsuit, criminal lawsuit, administrative complaint system, independent human rights commission/organization, mediation, community-based reconciliation (e.g. community elder, religious leader), equal opportunity commission/ombudsman
26. Do people with disabilities have the right to vote?
 yes
 no
27. Do people with disabilities have the right to vote?
 yes
 no

28. What percentage of voting booths is accessible?

- 0%- 20%
- 20%- 40%
- 40%- 60%
- 60%- 80%
- 80%- 100%

Confidence scale

➤ Please discuss accessibility in terms of communication access (alternative formats such as Braille), location of voting place, training of election officials to provide access to persons with disabilities, and whether information about the overall election process is available to persons with disabilities.

29. Do people with disabilities have the right to stand for election at all levels?

- yes
- no

28a. If no, please provide details

30. Are there one or more focal points for disability policy and planning at the level of the national government?

- yes
- no

29a. If yes provide details, (e.g. council, ombudsman, office, etc.)

➤ Check if disability offices exist within different branches of the government and within different ministries. Are disability policies integrated across different departments or are disability offices isolated? If there is an official coordination of policy and planning, is it effective?

31. Do people with disabilities have the right to immigrate and/ or seek asylum?

- yes
- no



32. Do people with disabilities have the right to form associations?
 yes
 no
33. Do persons with disabilities have the right to adopt children?
 yes
 no
34. Do families with children with disabilities have the right to keep and raise their children?
 yes
 no
- Are parents with disabilities discriminated against? If so, in what ways?

III. INCLUSION AND ACCESSIBILITY

This section focuses on the accessibility of various social sectors.

Communication

Report Card Questions:

35. Does the government provide a Braille version of the Constitution?
 yes
 no
- Where is it available? In libraries, in schools, other? Does the government regularly communicate its activities in alternative formats?
36. Is the national news captioned for hearing-impaired viewers?



- yes
- no

- Are there any government initiatives to create accessible communication networks?

- 37. Is there a method or strategy for people with speech impediments or hearing impairments to communicate with authorities in case of natural disaster, civil emergency or criminal assault?
 - yes
 - no
 - 36a. If yes, please provide details

- If no, how do people with these disabilities get help in an emergency? Is there a method (like TTY for emergency phone calls) in the cities but not elsewhere in the country?

- 38. Does the national library provide materials in alternative formats (e.g. Braille, audiocassette, large print, electronic)?
 - yes
 - no
 - 38a. If yes, when was the last time these materials were updated?

- In general how do individuals who require alternative-format information obtain information?
- What resources are available for alternative communication for people with multiple disabilities and their families, teachers and caregivers?

Education

Report Card Question

- 39. **Is training on teaching children with disabilities included in the national teacher curriculum?**
 - yes
 - no



For the following two questions please include information on education for children with multiple and/or severe disabilities.

40. Please provide the approximate percentages of elementary students with disabilities in your country that receive education in the following manner
- inclusive education (all students of the same grade are in the same classes)
 - students with disabilities are taught in special classes
 - students attend special day schools
 - students attend separate residential schools
 - students are taught at home
 - no education available for students with disabilities

Confidence scale

41. Please provide the approximate percentages of high school students with disabilities in your country that receive education in the following manner
- inclusive education (all students of the same grade are in the same classes)
 - students with disabilities are taught in special classes
 - students attend special day schools
 - students attend separate residential schools
 - students are taught at home
 - no education available for students with disabilities

Confidence scale

42. If education is available for students with disabilities in local elementary schools, where is it available?
- major cities
 - most small and large cities
 - countrywide
 - other _____



Confidence scale

43. If education is available for students with disabilities at special schools, where is it available?
 major cities
 most small and large cities
 countrywide
 other _____

Confidence scale

44. Is special education training available to teachers that wish to take it?
 yes
 no

➤ If there is no special education program available do schools provide a staff member to help students with disabilities? What kind of training do these staff members receive? Are family members expected to assist students with disabilities in the school? How is this accomplished?

45. How is the family integrated into the intellectual rehabilitation and education of people with severe, profound and/or multiple disabilities?

Confidence scale

46. What percentage of children aged 0-5 have a disability?
47. What percentage of children aged 6-16 have a disability?

Confidence scale

48. What percentage of students aged 6-16 in the public schools have a disability?

Confidence scale

49. Does the Ministry of Education have a program to detect disabilities in children?
 yes
 no
- 49a. If yes, please list which disabilities and what ages are covered.
- 49b. If yes, please indicate what percentage of schools participate in this program or activity
 0%- 20%
 20%- 40%
 40%- 60%
 60%- 80%
 80%- 100%

Confidence scale

50. Is there a national program for the early detection of disabilities?
 yes
 no
- 50a. If yes, which agency or ministry is responsible for its implementation?
- 50b. What disabilities are covered?
- What steps are taken when a disability is identified through early detection?
51. What kind of opportunities are available for people with intellectual disabilities over the age of 18?
52. Is there a national policy that requires schools to be accessible to people with disabilities
 yes
 no



52a. If yes, what kind of accessibility is covered

- Physical infrastructure
- Communications
- Teacher training
- Educational materials (alternative formatting)

Please include copies of policies regarding education and accessibility.

52b. What percentage of the schools are in compliance?

- 0%- 20%
- 20%- 40%
- 40%- 60%
- 60%- 80%
- 80%- 100%

Confidence scale

- There might be different estimates of the compliance rate between officials and disability advocates or parents of students with disabilities. Discuss and analyze any differences you find. Are there differences between rural and urban areas in the level of compliance?

53. Is the Ministry of Education accessible to wheelchair users?

- yes
- no

Please provide a photo of the Ministry of Education, or comparable public building, if possible.

Employment

Report Card Question

54. Does the largest employer in the private sector (name _____) have a policy that states people with disabilities cannot

be discriminated against in employment on the basis of his or her disability?

- yes*
 no

If yes, please provide a copy of the policy.

➤ *Does anyone with a disability actually work there?*

55. What is the unemployment rate for people with disabilities?

Confidence scale

➤ This information might be very difficult to come by. Discuss underemployment as well as unemployment and discuss the reasons for unemployment. Summarize the experience of people with disabilities who seek employment in the public and private sectors of the country. Also discuss the major barriers to employment. Some examples might be inaccessible work environment, lack of training programs or lack of transportation, cultural norms against employment of persons with disabilities.

56. Is there any national policy pertaining to people with disabilities and the ability to work?

- yes*
 no

If yes, please provide a copy of the policy.

57. Are there training and placement programs for people with disabilities?

- yes*
 no

57a. If yes, who runs these programs? (Check all that apply)

- national government
 religious organization
 UN agency
 other international agency
 non-religious NGO

- corporation
 other, please specify _____

- Discuss the effectiveness of the training and placement programs. Are there barriers to participation? Are the programs widespread or concentrated in major cities?
58. Is there a policy requiring the national government to employ people with disabilities?
 yes
 no
- Are there people with disabilities employed by the government? Are there any people with disabilities employed in middle and higher levels of the government? If not, why not?

Health Services

Report Card questions:

59. *Is training on provision of care to people with disabilities available for physicians, both before and after they acquire a medical degree?*
 yes
 no
- *If yes, how many physicians take advantage of this training each year?*
60. Does the Ministry of Health (or equivalent) provide any funding specifically for promoting the health or rehabilitation of people with disabilities?
 yes
 no
- *Describe the level of funding and the programming associated with this funding.*



61. Which of the following programs exist in your country?

- physical therapy training
- occupational therapy training
- physiatry training for nurses
- physiatry training for other health professionals
- prosthetics and orthotics training
- speech therapy

62. Has the national health service implemented a strategy of Community-Based Rehabilitation?

- yes
- no

➤ How is it being received, implemented and assessed? How widespread is it?

63. Which health professionals have access to training programs that focus on the provision of services to people with disabilities?

- Primary care physicians
- OB Gyns
- Pediatricians
- Nurses
- Physician Assistants
- Rural Health Workers

63a. For each of the medical specialties listed please indicate the percentage of professionals that have participated in disability training.

- Primary care physicians
- OB Gyns
- Pediatricians
- Nurses
- Physician Assistants
- Rural Health Workers

Confidence scale



➤ Discuss the scope and effectiveness of these services

64. Are there government-funded rehabilitation services available in the country?
 yes, in the major city
 yes, in larger cities
 yes, widespread
 no
65. Is there a publicly funded organization where persons with disabilities can obtain auxiliary materials, such as technical aids?
66. Is there a privately funded organization where persons with disabilities can obtain auxiliary materials, such as technical aids?
67. What measures are in place to prevent discrimination in health insurance coverage for persons with disabilities?

Housing

Report Card Question:

68. *Is there a center that provides peer counseling and referral services (Independent Living Center) to people with disability in your country?*

- yes
 no

68a. If yes, who operates these centers and its programs? (check all that apply)

- national government
 religious organization
 UN Agency
 other international agency
 NGO
 commercial entity
 other, please specify _____



➤ The independent living philosophy maintains that individuals with disabilities have the right to live with dignity and with appropriate support in their own homes, to fully participate in their communities, and to control and make decisions about their lives.

69. Please provide an overview of subsidies and/ or supports for housing for persons with disabilities

70. Are people with disabilities eligible for public housing?

- yes
- no
- not applicable

70a. If yes, is the housing (check all that apply):

- segregated
- institutional
- consistent with general living conditions
- integrated into the community
- accessible
- affordable

Confidence scale

Accessibility of the Built Environment

Report Card Question:

71. *Is the bus system in the capital city wheelchair accessible?*

- yes
- no
- not applicable

➤ *Is there special public transportation for people with disabilities, or is the existing transportation adapted? How do people with*



mobility disabilities get around if public transportation is not available or accessible?

Report Card Question:

72. *Is the main post office in the capital city wheelchair accessible?*

- yes
 no

If no, please provide a photo of the post office, if possible

73. Does your country have any regulations stating that public buildings and facilities must be accessible to people with disabilities?

- yes
 no

74. Approximately what percentage of public buildings are accessible to people with mobility disabilities?

Confidence scale

75. Does your country have any regulations stating that private buildings and facilities must be accessible to people with disabilities?

- yes
 no

➤ If yes, does this apply only to new construction or does it apply to existing buildings as well?

76. Are courses in accessibility engineering available to engineer trainees in your country?

- yes
 no



77. Are courses in Universal Design available to architects in your country?

- yes
 no

➤ How many engineers and architects take advantage of these courses, if available?

IV. DISABILITY ACTION and AWARENESS

Disability action involves a wide range of activities including those activities that increase the rights for people with disabilities, disability awareness in the communities, provision of disability services, coordination activities involving disability issues, and that increase the participation of people with disabilities in all activities of society. Disability action requires some sort of funding for its programs.

Disability awareness activities are focused at increasing community understanding of the physical, psychological and social barriers faced by people with disabilities. The purpose of disabilities awareness is to promote changes in community understanding of people with disabilities in order to facilitate full access and inclusion. Please complete an information form on each organization involved in disability action and awareness.

Report Card Question:

78. Is there a national coordinating organization that develops disability policy?

- yes
 no

78a. If yes, please describe its composition, including what percentage of members have disabilities, and its activities _____

79. Is there a national disability action plan?

- yes



no

If yes, please complete questions 80-83

If no, please discuss the obstacles to the development of such a plan

80. Is the plan based on recommendations from the coordinating organization?

yes
 no

81. Please summarize the major goals of this plan, the activities associated with those goals, and the budget

82. Does the national plan specifically include women with disabilities in its programming?

yes
 no

83. Who is responsible for ensuring the plan's implementation?

parliament/legislature
 government ministries
 national disability organization
 other _____

Please complete an information form on each major entity that provides services or conducts advocacy on behalf of people with disabilities

84. Are there cross-disability organizations in your country?

yes
 no

Please complete an information form on each one.



- In your opinion, are civil society associations that are interested in disability equipped to promote disability rights? If not, please discuss why
 - How are cross-disability and single-disability organizations funded? Do they get governmental assistance? Do they receive funding from international organizations or NGOs?
 - Do different disability-related organizations work in collaboration with one another? If not, why not?
85. Are there any University-level courses on
- disability policy
 - disability rights
 - inclusive education
 - other disability-related topics, please specify _____
- How many students take these courses each year? Who teaches the courses and what kind of support do the courses or programs receive?

Conducting a Panel Discussion

The questions contained in the panel discussion section are to be addressed to members of the disability community in your country. The goal is to gather opinions from disability leaders on the rights and conditions or persons with disabilities in your country. To obtain a variety of opinions, please invite a broadly representative group of seven to ten disability advocates.

The following is a guideline for how to set up and conduct this panel discussion. Please adapt the suggestions below to make them appropriate to your culture and/or environment. Also, please be mindful of your specific group of participants and adapt the suggestions in a way that will maximize the effectiveness of the panel discussion session.

As always, documentation is crucial. If you feel it will assist you, please consider using a tape recorder or have someone take notes of the discussion. Please remember to ask panel participants to indicate if they do not want to be identified personally or to have their quotes attributed to them personally in any future publications.

Participants: Seven to ten and disability advocates and representatives from Disability NGOs in your country. Select a widely representative group.

Facilitator: IDRM researcher

Objectives

1. To obtain answers to the eighteen questions contained in the panel question section of the IDRM research guide.

Timing

1. One month in advance: reserve accessible space for panel discussion. Contact NGOs and individual advocates that are currently involved in disability advocacy. Send invitations using the template provided along with project description and location information. The discussion will take place over a three hour period with a 15 minute coffee break.
2. 3-4 weeks in advance: plan food and beverage, plan sign language interpreters, create Braille texts.
3. One week in advance: double check logistics, arrange for any materials such as pens, paper, flip charts, chalk boards.
4. Day of event: arrive early to check arrangements and greet participants.



Materials for participants

1. Agenda
2. General project description and panel questions
3. Food and beverage at break, water available during discussion
4. pens, paper

Facilitator materials: Panel questionnaire, notebooks for transcription, tape recorder, if necessary.

Methodology:

Group discussion facilitated by a coordinator (IDRM researcher) who opens the discussion to the entire group, orients it through panel questions, summarizes responses and keeps a record of responses and discussion.

Techniques for facilitating discussion¹

1. Have participants and assistants introduce themselves and give a brief background.
2. Learn participant's names and address them by name.
3. Build comfort and trust by demonstrating that the discussion will follow a win-win model. The participants are not in competition with each other, but rather are participating together in a common enterprise. There are no "right" answers.

¹ Adapted from *Handbook for Graduate Teaching Assistants*, Department of Sociology, University of Virginia, 2000-2001. (www.virginia.edu/sociology/teachingweb/tahandbook/TA%20handbook.doc). Most materials originally found in R.G. Billingsley, "Facilitating Discussion," in *On Teaching*, vol. II. ed. Mary Ann Shea (Boulder: University of Colorado Faculty Teaching Program, 1987).



4. Whenever possible, have participants sit in a circle or facing each other. This de-emphasizes your role as facilitator and creates a physical reminder that you want participants to talk to each other, not just to you.
5. Encourage participants to actively listen to one another in discussion, rather than simply waiting for a chance to get in their own ideas.
6. Restate (in your own words) what someone else has said to make sure you understand it.
7. Give participants the appropriate tools for discussion. Provide the shared vocabulary. When necessary, ask participants to rephrase their comments.
8. Guide and monitor the discussion-lead the discussion so that it proceeds in an organized, goal-directed, and meaningful way.
9. When you have posed or elicited a good question for discussion, help participants keep it alive: wait for them to reflect and respond to the topic. If the question is a good one, participants may not be able to respond within seconds. Use silence constructively to give participants a chance to think and formulate a response. Don't rush in and answer the question for them before they've had a chance to think about it.
10. If the discussion wanders, restate the issue and remind everyone of the discussion objective.
11. Trust the discussion process: limit your own interventions.
12. Summarize major points that have been generated by the discussion.



V. PANEL RESEARCH QUESTIONS:

The following questions are to form the basis of a discussion among disability leaders in your country. The goal is to obtain a broad perspective of the condition of people with disabilities from a variety of interest groups. Some of the questions have a yes/no response format. While it will not be possible to obtain a unanimous answer on all of the questions, please record the majority opinion, then record how many participants expressed the opinions. A description and analysis of the discussion surrounding the questions is crucial, so please observe and record the conversation carefully.

Although the primary goal of the panel discussion is to obtain answers to the questions, another important goal is to bring awareness of the project to interested groups and to increase the organizational and cooperative capacities of the disability community.

I. IDENTIFYING THE DISABILITY COMMUNITY

This section focuses on those activities that are designed to identify people with disabilities.

86. Has there been greater than a 10% change in the number of people with disabilities in your country in the last 5 years?

yes
 no

Confidence scale

- 86a. If yes, is it an increase or decrease?

86b. What is your source of information?

86c. Please discuss the reasons for this change

87. Do you think the epidemiologic and survey data available gives an accurate picture of the disability situation in your country?

yes
 no



2a. If no, please elaborate _____

Confidence scale

88. Please list the five most relevant disability related studies, reports and articles focusing on your country that have been released in the past 5 years. Please provide bibliographic information in the format provided by the Research Guide.

II. DISABILITY RIGHTS

Human rights are universal and apply to those with and without a disability.

This set of questions focuses on the standards set by the international community, national governments and local authorities. Examples of international covenants, norms and agreements include the United Nations Standard Rules on the Equalization of Opportunities for People with Disabilities, the Universal Declaration of Human Rights, the UN Convention on Economic, Social and Cultural Rights, UN Convention on the Rights of the Child, Declaration on the Rights of Disabled Persons and the Principles for the Protection of Persons with Mental Illness.

89. What strategies are most effective for addressing human rights violations or discrimination against persons with disabilities?

Confidence scale

90. What are the obstacles to achieving more effective disability legislation?

- commercial or civil law
- red tape/ bureaucracy
- lack of political will
- cultural norms
- other, please specify _____

Confidence scale



91. Are human rights organizations in your country engaged on issues of importance to people with disabilities?

yes

no

91a. If no, why not? _____

III. INCLUSION AND ACCESSIBILITY

This section focuses on the accessibility of various social sectors.

92. What percentage of voting booths are accessible?

0%- 20%

20%- 40%

40%- 60%

60%- 80%

80%- 100%

Confidence scale

Please indicate the source of information

93. What are the major barriers to voting for people with disability?

Confidence scale

94. What are the major barriers to employment?

health insurance ineligibility

inaccessible work environment

transportation

lack of training programs

cultural barriers in hiring

lack of education



other, please specify _____

Confidence scale

95. Approximately what percentage of people with a disability are:

- living with family
- located in institutions
- located in clusters of adapted housing
- homeless
- other, please specify _____

Confidence scale

96. What steps should be taken for persons with disabilities to be free to choose their preferred housing?

IV. DISABILITY ACTION and AWARENESS

Disability action involves a wide range of activities including those activities that increase the rights for people with disabilities, disability awareness in the communities, provision of disability services, coordination activities involving disability issues, and that increase the participation of people with disabilities in all activities of society. Disability action requires some sort of funding for its programs.

Disability awareness activities are focused at increasing community understanding of the physical, psychological and social barriers faced by people with disabilities. The purpose of disabilities awareness is to promote changes in community understanding of people with disabilities in order to facilitate full access and inclusion. Please complete an information form on each organization involved in disability action and awareness.

97. Do disability groups in your country collaborate well?

- yes
- no



- 97a. If yes, on what activities? _____
- 97b. If no, why not? _____
98. What activities are most important in advancing the rights and agenda of persons with disabilities in your country?
99. What are the major obstacles to achieving more effective disability action?
- commercial or civil law
 - red tape/ bureaucracy
 - lack of political will
 - financial considerations
 - cultural obstacles
 - other, please explain _____

Confidence scale

100. Please discuss the disability advocacy and awareness programs taking place in your country. What are the goals of these activities? Who is managing these activities? What are the positive and/or negative effects of these activities?
101. Overall, how does the mass media portray people with disabilities
102. Provide one example of a media portrayal of disability from the past year.
103. Please list the common terms used to describe a person with disability and their meanings in each of the local languages. Provide the English translation of each term.



104. How does the government influence access to sport, recreation and culture for persons with disabilities?



CENTER FOR INTERNATIONAL
Rehabilitation

INTERNATIONAL DISABILITY RIGHTS MONITOR: 2003

QUESTIONS

Copyright 2001 Center for International Rehabilitation, All rights reserved

Page 43 of 49



Style Guide

The following recommendations are derived from the Chicago Manual of Style.² Examples are taken from the Writer's Handbook of the University of Wisconsin Writing Center, <http://www.wisc.edu/writing/Handbook/DocChiNotesFirstReference.html>

Footnotes

References are crucial to your report. If you have any questions regarding how or when to cite, please consult your regional research coordinator. Footnotes are numbered sequentially (1,2,3...) and appear at the bottom of the page. Microsoft Word has an easy footnoting system: click "insert" then "reference" on the drop down list, then "footnote".

The following are examples are the most common reference types:

Books

Book by a Single Author, First Edition:

Donald N. McCloskey, *Enterprise and Trade in Victorian Britain: Essays in Historical Economics* (London: George Allen and Unwin, 1981), 54.

Book by a Single Author, Later Edition:

Donald N. McCloskey, *The Applied Theory of Price*, 2nd ed. (New York: Macmillan, 1985), 24.

Book by Two or Three Authors:

Donald A. Lloyd and Harry R. Warfel, *American English and Its Cultural Setting* (New York: Alfred A. Knopf, 1956), 12.

² *The Chicago Manual of Style*, 14 ed. (Chicago: The University of Chicago Press, 1993).



Book by More than Three Authors:

Martin Greenberger et al., eds., *Networks for Research and Education: Sharing of Computer and Information Resources Nationwide* (Cambridge: MIT Press, 1974), 50.

Book by an Unknown Author:

College Bound Seniors (Princeton: College Board Publications, 1979), 1.

Chapter in an Edited Collection:

Ernest Kaiser, "The Literature of Harlem," in *Harlem: A Community in Transition*, ed. J. H. Clarke (New York: Citadel Press, 1964), 64.

Article in a Journal:

Louise M. Rosenblatt, "The Transactional Theory: Against Dualisms," *College English* 54 (1993): 380.

Newspaper Article:

Tyler Marshall, "200th Birthday of Grimms Celebrated," *Los Angeles Times*, 15 March 1985, sec. 1A, p. 3.

Government Document

Congressional Record, 71st Cong., 2nd sess., 1930, 72, pt. 10:10828:30.

Unpublished Material (Dissertation or Thesis)

James E. Hoard, "On the Foundations of Phonological Theory" (Ph.D. diss., University of Washington, 1967), 119.

Interview by Writer of Research Paper

Donna E. Shalala, interview by author, Madison, Wisconsin, 1 December 1992.

Material Obtained Through an Information Service

Susan J. Kupisch, "Stepping In," paper presented as part of the symposium *Disrupted and Reorganized Families at the annual meeting of the Southeastern Psychological Association*, Atlanta, Ga., 23-26 March 1983, *Dialog*, ERIC, ED 233276.

Secondary Source

Louis Zukofsky, "Sincerity and Objectification," *Poetry* 37 (February 1931): 269, quoted in Bonnie Costello, *Marianne Moore: Imaginary Possessions* (Cambridge and London: Harvard University Press, 1981), 78.

[The writer found the Zukofsky quotation in Costello's book, not in Zukofsky's original article.]

Interviews

Interviews should be footnoted using as much information as possible, including the full name of the person interviewed, the title or occupation, the place of employment, location of the interview, date of the interview.

Interview with Eileen Giron, Executive Director of ACOGHIBRI, San Salvador, 15 January 2003.

This information should be recorded in all cases, and the information retained in your secure files. If the source prefers to remain unidentified, please refer to the confidential interview guidelines as you create your report.

Confidential Interview

If necessary for security reasons, do not name the source but do indicate whether the interview was conducted in person or on the phone.

Interview with Minister of Health official, San Salvador, 7 February, 2003

Panel discussions

Include the names and titles of participants, location and date of the panel discussion.

Panel discussion with Francisco Jones of the Chilean Blind Union, Sandra Franco of the Chilean Deaf Federation, Juan Miro

QUESTIONS

Copyright 2001 Center for International Rehabilitation, All rights reserved



of Inclusion International, Chile, Rosaria Reina of the Chilean Chapter of the Inter-American Institute on Disability, Marie Dumas of the Chilean National Council on Disability, Fred Suarez of Disabled People International, Chile, Hotel Nacional, Santiago, 15 February 2003.

Again, refer to confidential interview guidelines or contact your regional coordinator if you have questions regarding identification of an individual or their remarks.

Internet sources

Give the URL (web site address) of the article, report or source quoted in addition to all the details you would provide for a book or article. Download a hard copy of any document you reference and keep it in your files.

Abbreviations and Acronyms

The first time an abbreviation or acronym is used, please spell out the full name that it represents. In subsequent usage, you may use the acronym. If you use many abbreviations and acronyms in your report, please attach a list with the full names.

The International Disability Rights Monitor (IDRM) is a project of the Center for International Rehabilitation (CIR). IDRM researchers will be gathering data throughout the Americas in 2003.

Bias-free language

Please be sensitive to issues of gender, race, ethnicity, religion, disability, age and sexual orientation by using neutral language. Alternate "he and she" or use "he or she".

Dates and Currencies

For dates, list the day, month, year without commas: 17 January 2001. All numbers under ten spelled out in text: seven ministers and 26 disability advocates.

Informal language

QUESTIONS



In general, more formal language is better than casual language. Aim for the tempo and tone found in a professional report. Remember that the report will be read worldwide by a broad audience including government officials, disability advocates, and the general public.

Format

For long quotes, such as personal histories that illustrate portions of the country report, indent the quotation and provide a footnote reference.

“It is important to note in understanding the context of disability in Mexico that while we have excellent hospitals and rehabilitation centers, there are only a few of these; and they are concentrated in the most important urban areas. Outside of these sites, only outpatient therapy is available unless you are rich and can afford a personal therapist, so people with disabilities have virtually no access to health care.”³

³ Fernando Rodriguez, quoted in James I. Charlton, *Nothing About us Without Us* (Berkeley: University of California Press, 1998), 103.



Submitting the report

Review the production schedule and plan out your research activities working backward from the date on which you must submit the report. In the Americas phase of the IDRM report, final reports are due 1 December 2003. This date is fixed, and any reports not submitted by that date will not be included in the final regional report.

The answers to the questionnaire are to be entered into the database via the website form and the text reports are to be submitted in "Word" format. You can enter the data into the questionnaire form with continual updating. The first draft of the country report and of the questionnaire form are due on 1 October 2003. On that date the regional coordinator will capture all the questionnaire responses as well as your country report in order to provide you with comments and suggestions on completing the final versions.

You can create the country report in a Word document and continue refining and editing it until submission of the first draft of the country report in October 2003. After this submission, the regional coordinator will return the report to you with comments for further refinement of the report. You final country report must be received by CIR by 1 December 2003 in order to be included in the final report on the Americas.

IDRM New York Training

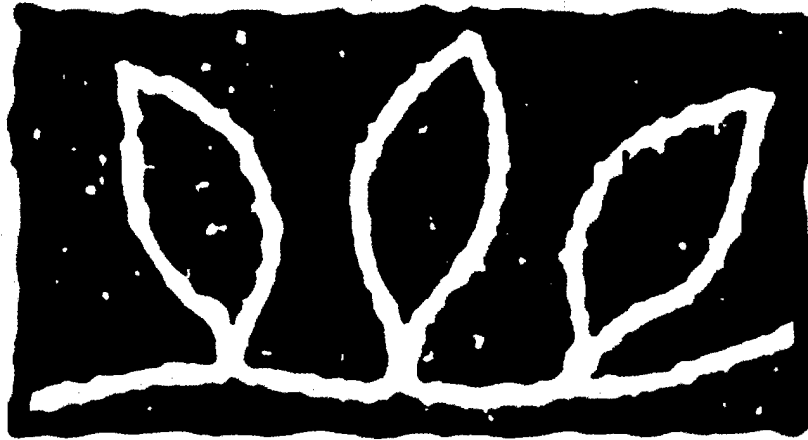

CENTER FOR INTERNATIONAL
Rehabilitation

15-17 June 2003

Please note: we will be conducting the training in Spanish and in English. Sessions marked in grey are held in both languages and take place in the Knightsbridge Room. The English language sessions will be held on the second floor in the Boardroom.

	Sunday 15	Tuesday 17
8:00	<i>Breakfast (Knightsbridge room)</i>	<i>Breakfast (Knightsbridge Room)</i>
9:00		Introduction (2 groups) to today's activities ----- Session V Methods and Style Guide (Spanish group) Prototype report (English group)
9:20		
9:30		
10:00		Session VI Prototype report (Spanish group)
10:30		Methods and Style Guide (English group)
11:00-11:15	<i>Break</i>	<i>Break</i>
11:15-12:00	Session II (2 groups) Questionnaire 1. Types of questions: description, how to answer them, and how to keep records 2. First section: Identifying the disability community	
12:00- 1:00	Session II (continuation) 3. Second section: Disability Rights 4. Third section: Inclusion and Accessibility	
1:00-2:00	<i>Lunch</i>	<i>Lunch</i>
2:00-2:45	Session II (continuation) 5. Continuing the Third Session 6. Fourth Session: Disability Awareness	
2:45-3:30	Session III Panel and Panel Questions	
3:30- 3:45	<i>Break</i>	
3:45- 5:00		

Sunday

9:00-9:20 ***Welcome and introduction to IDRM***

1. Goals of IDRM – Need for a Disability Convention
2. Objectives and Activities of IDRM

9:20-9:30 ***Break***

9:30-10:30 ***Session I***

Don Loller - Centers for Disease Control
**“Disability Data Users And Producers: Identifying The Needs
For Data”**

10:30-10:55 **IDRM and Disability Data**

11:00-11:15 ***Break***

11:15-12:00 ***Session II***

Questionnaire

1. Types of questions: description, how to answer them, and how to keep records
2. First section: Identifying the disability community

12:00- 1:00 ***Session II (continuation)***

3. Second section: Disability Rights
4. Third section: Inclusion and Accessibility

1:00-2:00 ***Lunch***

2:00-2:45 ***Session II (continuation)***

5. Continuing the Third Section
6. Fourth Section: Disability Awareness

2:45-3:30

Session III

Panel and Panel Questions

3:30- 3:45

Break

3:45- 5:00

Session IV

Turning your data into a report

Tuesday

9:00-10:00 **Session V**

1. Spanish Group

Methods and Style Guide

2. English Group

Prototype report

10:00-11:00 1. English Group

Methods and Style Guide

2. Spanish Group

Prototype report

11:00- 11:15 **Break**

11:15- 1:00 **Session VII**

Advocacy, Public Relations and Media

Session VIII

Procedures during July/December period

Closing remarks



Disability Rights



»Disability Rights Online Survey

»Identifying the Disability Community

- Questions 1-5
- Questions 6-10

»Disability Rights

»Inclusion

»Disability Action and Awareness

Disability Rights Information

I. IDENTIFYING THE DISABILITY COMMUNITY

This section focuses on those activities that are designed to identify people with a disability.

[Next >>](#)

QUESTION 1

Report Card Question:

1. What is the total number of persons with disabilities in your country?

Confidence Scale

1	2	3	4	5	6	7	8	9	10
●	●	●	●	●	●	●	●	●	●

Confidence Explain

QUESTION 2

2. What percentage of the general population is comprised of people with a disability?

Confidence Scale

1	2	3	4	5	6	7	8	9	10
●	●	●	●	●	●	●	●	●	●

Confidence Explain

Indicate the source of this population information

• Population data can be found via the national census bureau, other national statistics offices, health ministries, or other governmental ministries. National libraries often keep updated information of this nature, and governmental websites sometimes maintain this data as well.

• If officials provide statistics, find out where the data comes from. If the source is UN or World Bank or another international source, ask officials why these data are used.

Disability Rights



»Disability Rights Online Survey

»Identifying the Disability Community
Questions 1-5
• Questions 6-10

»Disability Rights

»Inclusion

»Disability Action and Awareness

Disability Rights Information

I. IDENTIFYING THE DISABILITY COMMUNITY

This section focuses on those activities that are designed to identify people with a disability

[<< Previous](#)

[Next >>](#)

QUESTION 6

6. Has any data been gathered on people with disabilities in your country in the last 5 years?

- Yes
- No

6a. If yes please provide references

Text input field for references

6b. If no, when was data last gathered?

Text input field for date

Confidence Scale

1	2	3	4	5	6	7	8	9	10
●	●	●	●	●	●	●	●	●	●

Confidence Explain

Text input field for confidence explanation

• If there has been more than one disability survey conducted, compare and assess their results and/or methodology



CIR Network

Education

Engineering

Land Mine Awareness

Children Services

Disability Rights

English

Home

» Site Map

| About Us

| Fact Sheet

| News

| Links

| Contact Us

| Help

Disability Rights



»Disability Rights Online Survey

»Identifying the Disability Community

»Disability Rights

- Questions 11-15
- Questions 16-20
- Questions 21-25
- Questions 26-34

»Inclusion

»Disability Action and Awareness

Disability Rights Information

II. DISABILITY RIGHTS

Human rights are universal and apply to those with and without a disability.

This set of questions focuses on the standards set by the international community, nation governments and local authorities. Examples of international covenants, norms and agreements include the United Nations Standard Rules on the Equalization of Opportunities for People with Disabilities, the Universal Declaration of Human Rights, the UN Convention on Economic, Social and Cultural Rights, the UN Convention on the Rights of the Child, the Declaration on the Rights of Disabled Persons and the Principles for the Protection of Persons with Mental Illness.

Please identify respondents by name, if appropriate, and by title.

<< Previous

Next >>

QUESTION 11

Report Card Question:

11. Is there a national law that specifically references and protects of the rights of people with disabilities?

- Yes
- No

11a. What is the definition of disability under this law?

11b. What groups of people are covered under this law?

• Again, contrasting this definition to definitions used in other policies and laws is useful.

CENTER FOR INTERNATIONAL REHABILITATION
Annual Report to the Department of Defense
#DAMD17-00-1-0711

APPENDIX F

Course evaluation results from students and mentors
Campus Virtual Application



All responses are with respect to the Transtibial Prosthetics courses initiated February 17, 2003 and completed September 20, 2003. Of the 29 students who began the course (25 Bosnian, 4 Slovenian), 24 completed (20 Bosnian, 4 Slovenian) the course requirements successfully. Of those students leaving and entering the course the following information is available:

- 1 student withdrew because of inadequate education background to prepare him for the course (and resulting in closer attention to this student readiness variable)
- 2 students withdrew because they were close to retirement and underestimated the amount of work required for the course
- 1 student withdrew because of change of occupation
- 1 student withdrew because his position was terminated at his workshop
- 1 student was added during the course because of a student slot opening and because of his willingness and availability to spend extra time to “catch up” with the remainder of the student cohort during the ongoing transtibial course

Tools Usage

The following set of graphs indicates student perceptions of the frequency with which they used tools for the transtibial prosthetics course. When asked to respond to the following question, students replied as shown in the table below. Two mentors (a prosthetics mentor and an computer mentor) also reported on the tools usage. Their responses are recorded in the table below in the bracketed numbers beside the student responses.

“How often did you use each of the following tools for the Transtibial course?”

	No reply	Never	Monthly	Bi-weekly	Weekly	Daily
Web browser to view CIR modules	0	0	0	2	11 (2)	5
Paper copies to view CIR modules	1	4	2 (2)	3	7	1
Web browser to get prosthetic-related information outside of WebCT	3 (0)	2 (1)	6	1	3	3
Telephone (used for the course)	1	9 (1)	1	3	1 (1)	3
Mail Tool using WebCT	1	1 (1)	6	3	4	3 (1)
Email tools outside of WebCT	2	7 (1)	1	2	3	3 (1)
Discussion Tool in WebCT	1	0 (1)	3	2	12	0 (1)
Glossary Tool in WebCT	1	5 (1)	3	1	7 (1)	1
Search Tool in WebCT	2	2 (1)	2	2	5 (1)	5
Chat Tool in WebCT	2	0	1	1	14 (2)	0
Acrobat Reader (to view PDF files)	5	5 (1)	3	0	2 (1)	3
Camera	1	5	7 (1)	2	3 (1)	0
Other technology used (scanner)	11	5 (1)	2	0 (1)	0	0

Course Evaluations
Transtibial Prosthetics Course for Bosnia and Slovenia

Students were also asked to report about the location from which they used a computer to access the transtibial course. Students were asked to check all locations that applied to their computer use, so the categories of location of computer use were non-exclusive. Seventeen of the 18 students responding to this question indicated accessing the transtibial course from their workshop center. Five students accessed the computer from their home locations.

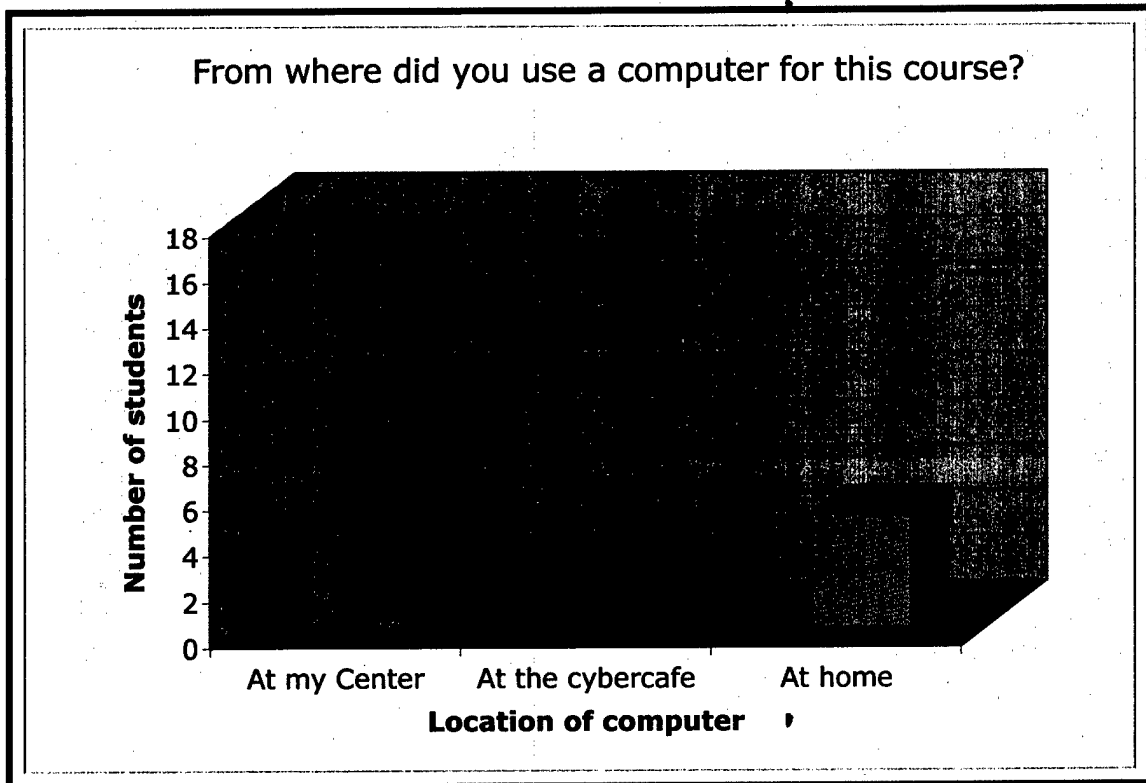

Student Ratings

Eighteen of the 24 students responded to the survey at the time of their final examinations for the transtibial course and their responses are reported below along side the category of the course they were asked to rate. Overall, students were quite favorably impressed with their instruction and the technical support available for the course and were favorably disposed to the content of the course. The one aspect of the transtibial course that was least favorably received it was the online chat sessions, which have been modified in administration and emphasis for the transfemoral prosthetics course.

Please rate each course category according to the given scale:

Instructor: Christian Schlierf

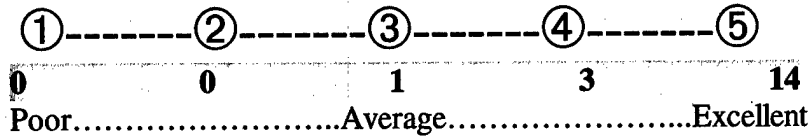

Your Mentor (no reply = 1)

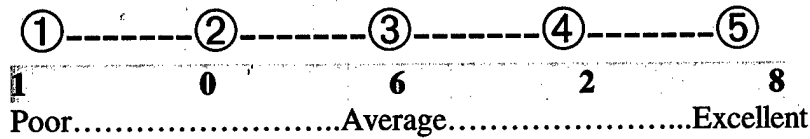

Technical Support

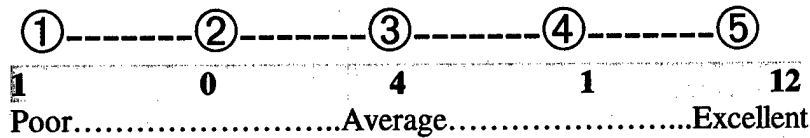

Organization of the course

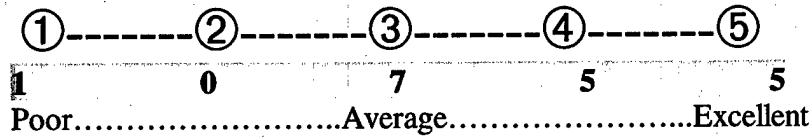

Content

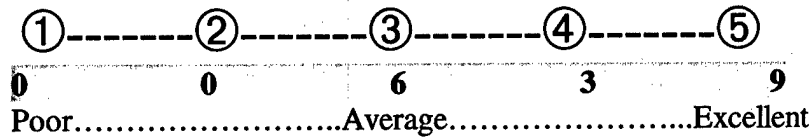

Online chat

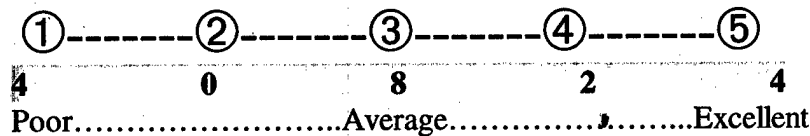

Please rate each statement according to the given scale:

The expectations were clearly stated for the Transtibial/Transfemoral course.

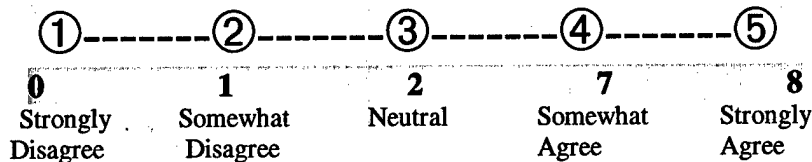

I was pleased with my interactions with my mentor.

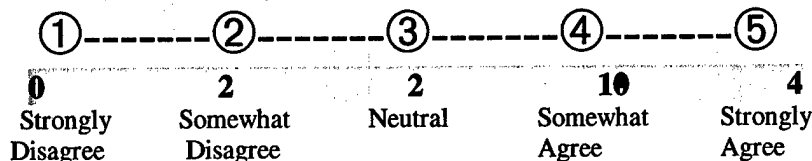

I received adequate support from the regional technical support personnel.

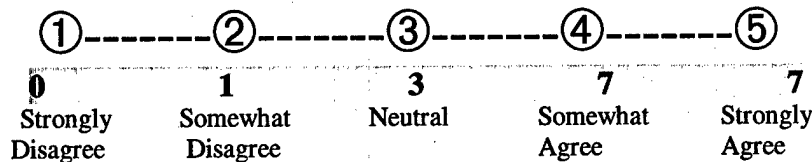

Please rate each statement according to the given scale:

I was comfortable using the computer for this course.

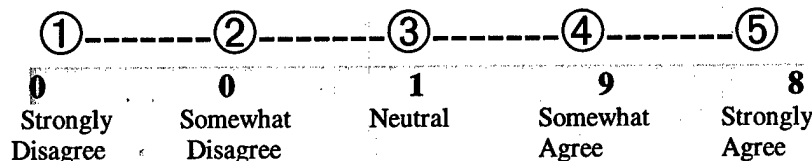

I was able to spend as much time as needed using the computer for this course.

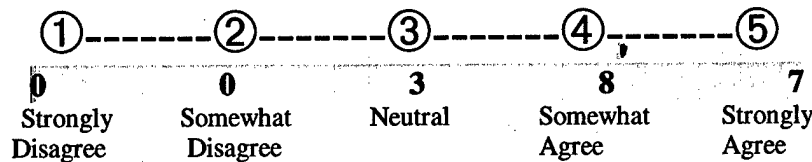

Mentor Ratings

Each of the two mentors (one for prosthetics, one for computer support) responded to the course evaluation questionnaire. Both mentors agreed that their role was clearly defined, and both indicating being able to spend enough time with the students of the course. It is notable that one mentor indicated some discomfort using the computer and because of this special instruction will be offered to increase his level of familiarity and comfort with course related tasks.

Please rate each course category according to the given scale:

Instructor: Christian Schlierf

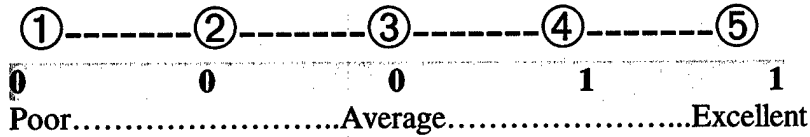

Technical Support

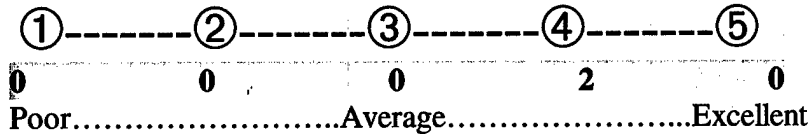

Organization of the course

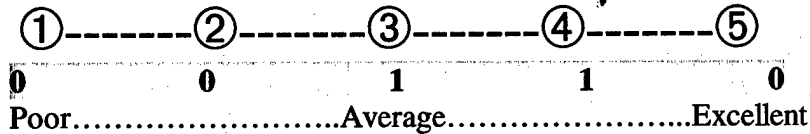

Content

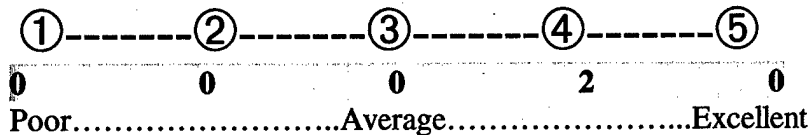

Design layout of online materials

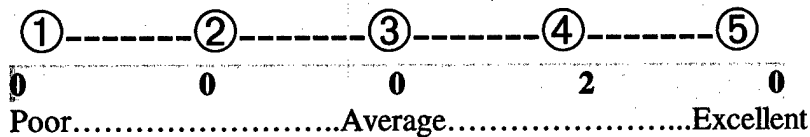

Online chat

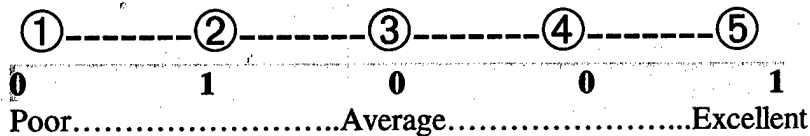

Please rate each statement according to the given scale:

The amount of work for mentors was...

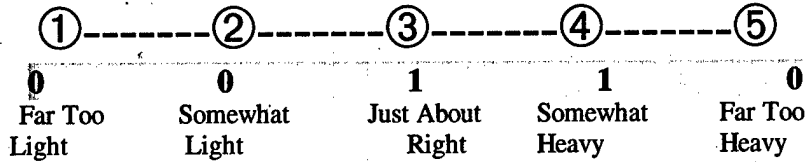

The mentor's role with regard to students was clearly defined.

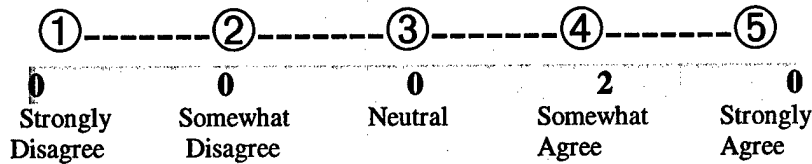

Mentors were given adequate directions before and during the courses.

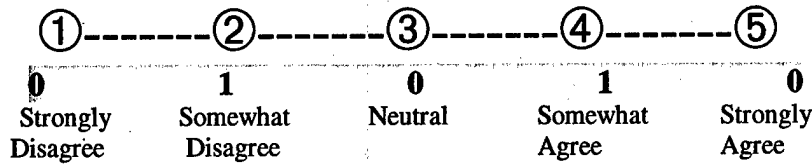

I was pleased with my interactions with the instructor.

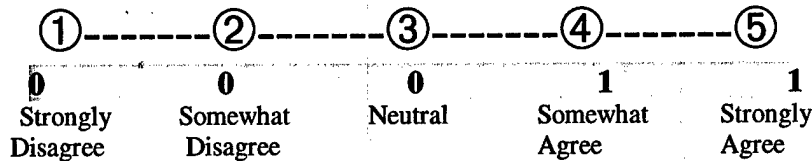

I received adequate support from the regional technical support personnel.

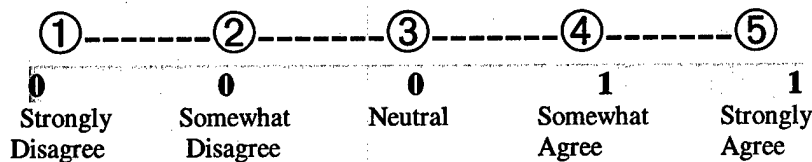

I was comfortable using the computer for this course.

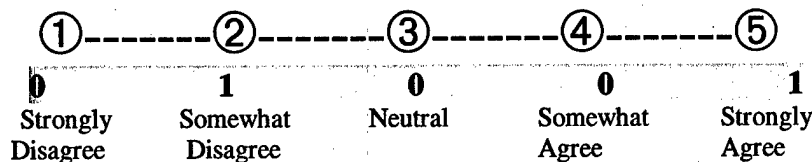

I was able to spend as much time as needed with students for this course.

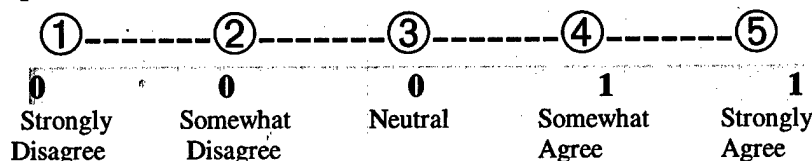

Student and Mentor Comments

Translated comments are recorded below verbatim. Mentor comments are preceded by notation indicating as such. Students appreciated the theoretical as well as the practical content of the course, with at least one student directly requesting more time should be spent on practical activities in the students' workshop centers, and another requested additional staff be made available to help manage the practical sessions.

What did you learn in this course that was most helpful?

- A lot of things
 - Some new details about the production of transtibial prosthesis
 - Some modules where a little bit different. That's why they were interesting for me.
 - Some information about transtibial prosthetics and basic introduction on PC computer.
 - I upgraded my knowledge.
 - The transtibial module set according to CIR technique.
 - Many things.
 - Many things. The new approach to the manufacture of transtibial prosthesis.
 - The production of below knee prosthesis, use of new materials, new terms, and communication via Internet.
 - Everything that I have learned so far was very useful...content and the practical part.
 - A little bit of everything.
 - Everything was useful (IT, anatomy materials, the procedure of production of a prosthesis).
 - Many things regarding production of transtibial prosthesis.
 - Some new details (very important).
 - **Mentor comment...**From time to time, I could not reach the CIR webpage.
-

To help us improve this course, what areas of this course were most confusing or which topics would you like more information about?

- There are some mistakes that should be corrected (there are so many of them).
 - We haven't seen Berkeley alignment system. We haven't worked with polyester resins (we were studying about it).
 - Not too bad.
 - Nothing.
 - Zero.
 - Nothing special.
 - From anatomy.
 - Dynamic alignment (adjustment). And the practical workshop.
 - Instructions for IT, because I am a beginner.
-

- Cast technique.

What changes would you make for the next course?

- We would test the Berkeley alignment system. Regarding to lamination process, we would study acrylic resins and not the polyester ones (because polyester is more toxic)
 - Not bad.
 - Reduce the number of people in the groups during the workshops. Using better quality of materials during the workshops (cast, polypropylene)
 - To organize practical workshops during Friday, Saturday, and Sunday (long weekends).
 - Nothing.
 - More instruction during the practical part of the course.
 - More practical work if is possible in *our* workshops.
 - A lot, there was a lot of incorrect information so I would change that and a better to students.
 - Nothing special, everything is OK.
 - To make theory portion of the course more intense.
 - **Mentor comment...**More computer (IT) support.
 - **Mentor comment...**I would like to change chat so that administrator could ban (or prohibit) students who were not following the topic.
-

Additional comments and suggestions...

- The chats were very bad up to now. Not all technical briefs and case presentations were posted on the WebCT website. The lack of the authority of the instructor regarding that. The participation in chat sessions should be marked. The main suggestion would be that the number of people in the group should be reduced and that only the ones that would like to study should be in the class.
 - Nothing.
 - Improve chats; increase the number of people participating in them. Discussions should be more constructive.
 - Nothing.
 - I disagree with the practical evaluation. According to my opinion the practical evaluation should be more series and consist of more people from the practical field. I am against the involvement of the new students in the project and they who were not involved in the Transtibial course. Take care about translation.
 - According to my opinion everything was relatively well organized with little mistakes.
 - I am very satisfied with the goal of the project, but I am disappointed with the approach of the bigger part of the students involved in this project.
 - CIR staff in Tuzla and Chicago have to listen to students needs. That is the key for the success of this project. Tuzla CIR staff has to do more for recognition of this program in governmental institution.
-

Instructor Ratings of the Transtibial Course Experience

The instructor for the Transtibial Course was interviewed and also asked to provide ratings of tools usage and the.....

Please rate each course category according to the given scale:

Mentor Rating for Practical Activities

①-----②-----③-----④-----⑤

Poor.....Average.....Excellent

Mentor Rating for Theoretical Activities

①-----②-----③-----④-----⑤

Poor.....Average.....Excellent

Technical Support provided by regional IT staff

①-----②-----③-----④-----⑤

Poor.....Average.....Excellent

Local Administrative Support

①-----②-----③-----④-----⑤

Poor.....Average.....Excellent

Chicago Administrative Support

①-----②-----③-----④-----⑤

Poor.....Average.....Excellent

Organization of the course

①-----②-----③-----④-----⑤

Poor.....Average.....Excellent

Content

①-----②-----③-----④-----⑤

Poor.....Average.....Excellent

Some materials use, like polyester resin, were shown to students but are not used in the region.

Design layout of online materials

①-----②-----③-----④-----⑤

Poor.....Average.....Excellent

Online chat

①-----②-----③-----④-----⑤

Poor.....Average.....Excellent

This has been modified for the Transfemoral course because it was difficult to manage with students existing schedules and also to manage online conversational habits.

Course Evaluations
Transtibial Prosthetics Course for Bosnia and Slovenia

Please rate each statement according to the given scale:

The amount of work for instructor was...

①-----②-----③-----④-----⑤
Far Too Somewhat Just About Somewhat Far Too
Light Light Right Heavy Heavy

The instructor's role with regard to students was clearly defined.

①-----②-----③-----④-----⑤
Strongly Somewhat Neutral Somewhat Strongly
Disagree Disagree Agree Agree

The instructor was given adequate directions before and during the course.

①-----②-----③-----④-----⑤
Strongly Somewhat Neutral Somewhat Strongly
Disagree Disagree Agree Agree

Only a couple of days orientation were available prior to taking charge of the Transtibial Prosthetics course in Bosnia (and Slovenia). At the time this was barely adequate for the task and would have appreciated more direction at the beginning. Now, with the Transfemoral Prosthetics course, it will be no problem because of the experiences gained and lessons learned during the Transtibial course.

I was pleased with my interactions with the mentor.

①-----②-----③-----④-----⑤
Strongly Somewhat Neutral Somewhat Strongly
Disagree Disagree Agree Agree

I received adequate support from the local/regional technical support personnel.

①-----②-----③-----④-----⑤
Strongly Somewhat Neutral Somewhat Strongly
Disagree Disagree Agree Agree

I would like to mention especially that our translator, Emina Hasanovic, has been especially helpful and has played a role far beyond the role of simply translation to include some of the administrative aspects of supporting the course. This was partially because the prosthetic mentor was less familiar with working on the computer and organizing students' course experiences.

I was comfortable using the computer for this course.

①-----②-----③-----④-----⑤
Strongly Somewhat Neutral Somewhat Strongly
Disagree Disagree Agree Agree

I was able to spend as much time as needed with students for this course.

①-----②-----③-----④-----⑤
Strongly Somewhat Neutral Somewhat Strongly
Disagree Disagree Agree Agree

I would appreciate to have more time on site visits and have more time for practical activities.

Course Description

The Lower Extremity Prosthetics Distance Learning (DL) program was originally designed as an 8-month course including study of a Transtibial Module Set (12 modules) and a Transfemoral Module Set (11 modules), with each module set containing resources for academic and clinical/practical training. The academic portion requires approximately 20 days (160 hours) of didactic training, 3 days (24 hours) of supervised clinical work. The clinical/practical portion includes 16 days (128 hours) of supervised and unsupervised hands-on clinical/practical work.

This course has been piloted successfully with 24 students participating from 10 different prosthetic facilities of 3 different countries in Latin America. Currently, the Center for International Rehabilitation is offering this course to 31 students from Bosnia and Slovenia.

Target Population

This course was developed to meet the continuing education needs of technicians who have had prosthetics experience, but who may not have the resources or for other reasons are unable to attend a formal university training program.

Prerequisite(s) and recommended background

Course prerequisites include a minimum of three years of hands-on clinical prosthetic experience. Participants were also required to be a working member of a prosthetic facility. Registration of participants has typically been accomplished through prior arrangement with an administrator of an existing prosthetic facility. The following are recommended prerequisite courses for participants:

- General Biology with Lab
- Chemistry with Lab
- Mathematics
- Psychology
- Suggested Electives: drafting, mechanical engineering, welding,

carpentry, and art (sculpting)

Overall Course Goals and Competencies to be Developed

- Trainees will be able to utilize the computer to use for the course.
- Use appropriate communication skills and medical terminology.
- Develop a prosthetic treatment plan to suit the needs of the individual.
- Cast, fabricate and fit the prosthetic device which best meets the patient's needs
- Evaluate fit and function of the device and make the necessary adjustments needed and make periodic evaluations of patient's progress.
- Be responsible for record keeping and for the development and implementation of a good prosthetic rehabilitation and follow-up plan.
- Assess quality and outcomes of service provided.
- Treat the amputee with respect and confidentiality.
- For each module set, the prosthetic center will be responsible for the presentation of one lower extremity amputee treated at their center.
- Work with other members of the rehabilitation team and understand the importance of their contributions in a comprehensive rehabilitation process.
- Each trainee will be required to submit a paper or "technical brief" on a prosthetic lower extremity related topic.
- Be open to research and development in the field of prosthetics and contribute by reporting findings in CIR's technical briefs, professional meetings, and publishing in journals.
- Recognize the importance of analyzing new concepts, methods, materials and components in prosthetics prior adopting them for use.
- Through a three-day workshop, the trainees will have the opportunity to use their communication, patient management, education, and prosthetic skills through actual encounters with patients, under the direct supervision of CIR staff.

Learning Goals

See Appendix A: Learner Goals and Objectives for the Transtibial Prosthetics Module Set.

Methodology

Description and organization of the Contents

Duration and Planning of Time

Evaluation System

Entry Exam Pre-course (written) evaluation (not graded, but required)	0 points
Unsupervised treatment	200 points
Modular quizzes	100 points
Case Presentations(1 per center)	100 points
Technical Brief (1 per student): 50 pts for chat room, 50 pts for bulletin board	100 points
Participation in Discussions	100 points
Hands on practical workshop	200 points
Final Exam	200 points
1000 points total- 700 (70%) is required to pass	

Working Plan**Human Resources****Didactic Resources****Justification of the Design of the Program**

Records of the Program and Assessment**Requirements for Course Completion****Pre-course evaluation**

The pre-course evaluation is given at the beginning of the course to evaluate the understanding of the material that will be covered. This is used as a measure and is not included in the final grade.

Quizzes

At the end of each module will be a short quiz of 5 questions. If you get 3 out of 5 correct, you will be able to move on to the next module.

Case Presentation

Each prosthetic center will be responsible for the presentation of one lower extremity amputee treated at their center. The case presentation will include the clinical history, prosthetic evaluation, prescription, fitting, and other relevant information regarding involvement of other members of the rehabilitation team in the functional rehabilitation of the patient. There will be an assigned time to present the case online and respond to questions and comments.

Evaluation criteria for case presentations:

- Case presentation relates to Lower extremity prosthetics.
- Case presentation contains basic information, description and treatment plan.
- Photographs and/or illustrations are included that show the patient's condition.
- Student shows a good understanding of the diagnosis and prosthetic treatment of the patient.
- Fielding questions and comments during the discussion and in the forum.

Technical Brief

Each trainee will be required to submit a paper or "technical brief" on a prosthetic lower extremity related topic. These papers and case presentations will be mounted on the Web and will be available for discussion and for educational purposes. The CIR will select one or more of these papers for publication in the CIR's newsletter.

Criteria for Technical Brief:

- Technical Brief relates to Lower extremity prosthetics.
- Illustrations are used when necessary.

- Technical topic is helpful and show ingenuity.
- Paper shows a good understanding of the technique described.

Participation in discussions

Each student will be responsible for participating in discussions. There are 2 areas that this will include:

- Weekly chat conferences – There will be a discussion regarding a case of a lecture. Each student should participate with thoughtful comments and questions. There will be a posting in the Discussion area for those not able to make the times. Those not able to make the conference should view the transcript in the forum and post their questions.
- Posting comments and recommendations for case presentations (one per week) in the forum.

Final Exam

The final exam will be proctored during the practical at the end of the course and consists of approximately 120 questions

Hands on practical workshop

Each student will have the opportunity to demonstrate their skill in a live workshop held at the end of the course.

Professors associated with Development of the Program
(include "curriculum and experience")

Project Director:	Dr. William Kennedy Smith
Managing Editors:	Hector Casanova, Dr. William K. Smith
Content Specialists:	Elaine Ulendahl, Hector Casanova
Illustrations:	Hector Casanova, Dr. Yeongchi Wu
Medical Consultation:	Dr. Yeongchi Wu and Dr. Skip Meier
Prosthetic Specialist:	Marc Edwards
Content Panel:	Sepp Heim, Dr. Terry Supan, Dr. Mark Quigley
Content Review:	Dr. Mark Brynsik, Dr. Margaret Meier, Stephanie Fatone

Web access to the Program

1. Go to <http://cirnetwork.org:8900/webct/public/home.pl>
2. Log on to my WebCT using the following information:
User Name = guest
Password = guest
3. Select from the left-hand column "Transtibial Prosthetics (CIR Demo)

Contact Person

Michael Potts
Project Manager
Center for International Rehabilitation
V.A. Lakeside, 2nd Floor Annex
333 E. Huron Street
Chicago, IL 60611
Phone: 312.926.3402
Fax: 312.926.7662
mpotts@cirnetwork.org

Language(s) supported

English, Spanish, Bosnian

Appendix A:

Learner Goals and Objectives for the Transtibial Prosthetics Module Set

TRANSIBIAL PROSTHETICS MODULE SET

Module Number	Module Title	Goals	Objectives
1	Basic Lower Extremity Anatomy	By the completion of this module you should have a basic understanding of the anatomical principles necessary to produce a well-fitting prosthesis.	<p>Apply knowledge of basic lower extremity anatomy when assessing the prosthetics needs of an amputee. You should be able to identify the anatomical structures and understand their related function. This will include:</p> <ul style="list-style-type: none"> • Planes of the body • Center of gravity • Terms of direction • Osteology • Myology • Pressure sensitive areas
2	Patient Prosthetic Evaluation	You should be able to assess the physical and functional condition of the patient and of the residual limb.	<p>Using a variety of patient evaluation procedures and measurements techniques to determine the needs of the patient.</p> <ul style="list-style-type: none"> • Evaluate special conditions of the patient. • Develop an appropriate prosthetic treatment plan • You will have an understanding of the shape of the residual limb and how this may affect prosthetic fitting • You will have an understanding of conditions such as tissue, skin, patella, and range of motion of the patient.

TRANSFIBIAL PROSTHETICS MODULE SET			
Module Number	Module Title	Goals	Objectives
3	Prosthetic Measuring Techniques	During this module you should have an understanding of various measuring techniques and be able to measure a patient.	<p>You will be able to:</p> <ul style="list-style-type: none"> • Measure and record the Medial-Lateral dimension • Measure and record the length of the limb • Measure and record the Anterior-Posterior dimension • Measure and record the sound limb
4	Prosthetic Casting Techniques	You will learn how to take an impression of the residual limb. You will be casting for patellar-tendon-bearing (PTB) and supracondylar sockets.	<p>You will be able to:</p> <ul style="list-style-type: none"> • Know what materials are needed to cast a patient • Learn the two-stage casting procedure for PTB • Learn the three-stage casting procedure for PTB supracondylar • Form the AP and ML areas • Make a reference alignment line • Evaluate the negative cast • Make the plaster mold

TRANSIBIAL PROSTHETICS MODULE SET		
Module Number	Module Title	Objectives
5	Modification of the Positive Mold	<p>You will be able to:</p> <ul style="list-style-type: none"> • Establishing general trim lines • Evaluate and record AP and ML dimensions • Compare cast measurements to anatomical • Remove plaster form the model in areas where socket pressure is desired • Create plaster build-ups in areas where low socket pressure is required • Modify the supracondylar region
6	Fabrication of Soft Liner	<p>You will be able to:</p> <ul style="list-style-type: none"> • Have an understanding of the purposes, advantages and disadvantages, and special considerations of a soft liner. • Be able to fabricate the distal padding • Be able to fabricate the soft liner • Be able to fabricate the soft liner for supracondylar suspension

TRANSIBIAL PROSTHETICS MODULE SET			
Module Number	Module Title	Goals	Objectives
7	Materials Used in Plastic Lamination	After completing this section, you will know the various properties of materials that are used during the lamination process.	<p>You will be able to:</p> <ul style="list-style-type: none"> • Know the materials used in prosthetic lamination • Have an understanding of mixing chemicals for lamination materials • Have an understanding shelf life and safety for lamination materials • Have an understanding of lamination fabrics and principles
8	Lay Up and Plastic Lamination	When you finish this module you will be able to use the lamination procedure described to create a light and durable prosthetic socket.	<p>You will be able to:</p> <ul style="list-style-type: none"> • Review basic materials and tools for creating a lay up • Be able to create the lay up • Review basic materials and tools for lamination • Work with plastic lamination

TRANSIBIAL PROSTHETICS MODULE SET		
Module Number	Module Title	Objectives
9	<p>Socket Fabrication and Bench Alignment</p> <p>At the end of this module you will be able to establish trim lines on a laminated socket, trim it and place it on an adjustable alignment system. You will also have an understanding of the Berkeley Adjustable Alignment Jig and the endoskeletal system.</p>	<p>You will be able to:</p> <ul style="list-style-type: none"> • Remove the prosthetic socket from the plaster mold • Establish the trim lines • Understand Berkeley Adjustable leg and endoskeletal alignment systems • Know flexion and adduction angles • Attach a prosthetic foot • Align the sagittal and coronal planes • Attach the socket to the alignment system
10	<p>Suspension Systems</p> <p>When finishing this module you should be able to evaluate and properly adjust prosthetic suspension systems.</p>	<p>You will be able to:</p> <ul style="list-style-type: none"> • Have an understanding of the purpose of the suspension systems • Know the parts of the cuff suspension strap • Know the forms of the suspension systems

TRANSIBIAL PROSTHETICS MODULE SET		
Module Number	Module Title	Objectives
11	Static Alignment	<p>You will be able to:</p> <ul style="list-style-type: none"> • Don the prosthesis • Evaluate the height • Trouble shoot in the sagittal plane • Make adjustments on a Berkeley adjustable leg • Make adjustments on a modular system • Trouble shoot in the coronal plane • Understand special considerations in static alignment
12	Gait Terminology and Dynamic Alignment	<p>You will be able to:</p> <ul style="list-style-type: none"> • Have an understanding of gait deviations • Understand the human walking cycle • Understand heel compression • Make and show evaluations • Compare normal gait and gait deviations • Know the causes and solutions of gait deviations

Appendix B:

Learner Goals and Objectives for the Transfemoral Prosthetics Module Set

TRANSEMEMORAL PROSTHETICS MODULE SET		
Module Number	Module Title	Goals
1	Basic Lower Extremity Anatomy	By the completion of this module you should have a basic understanding of the anatomical principles necessary to produce a well-fitting prosthesis.
		<p>Objectives</p> <p>Apply knowledge of basic lower extremity anatomy when assessing the prosthetics needs of an amputee. You should be able to identify the anatomical structures and understand their related function. This will include:</p> <ul style="list-style-type: none"> • Planes of the body • Center of gravity • Terms of direction • Osteology • Myology • Pressure sensitive areas
2	Patient Prosthetic Evaluation	You should be able to assess the physical and functional condition of the patient and of the residual limb.
		<p>Using a variety of patient evaluation procedures and measurements techniques to determine the needs of the patient.</p> <ul style="list-style-type: none"> • Evaluate special conditions of the patient. • Develop an appropriate prosthetic treatment plan • You will have an understanding of the shape of the residual limb and how this may affect prosthetic fitting • You will have an understanding of conditions such as tissue, skin, patella, and range of motion of the patient.

TRANSFEMORAL PROSTHETICS MODULE SET			
Module Number	Module Title	Goals	Objectives
3	Prosthetic Measuring Techniques	During this module you should have an understanding of various measuring techniques and be able to measure a patient.	<p>You will be able to:</p> <ul style="list-style-type: none"> • Measure and record the Medial-Lateral dimension • Measure and record the length of the limb • Measure and record the Anterior-Posterior dimension • Measure and record the sound limb
4	Prosthetic Casting Techniques	You will learn how to take an impression of the residual limb. You will be casting for patellar-tendon-bearing (PTB) and supracondylar sockets.	<p>You will be able to:</p> <ul style="list-style-type: none"> • Know what materials are needed to cast a patient • Learn the two-stage casting procedure for PTB • Learn the three-stage casting procedure for PTB supracondylar • Form the AP and ML areas • Make a reference alignment line • Evaluate the negative cast • Make the plaster mold

TRANSFEMORAL PROSTHETICS MODULE SET			
Module Number	Module Title	Goals	Objectives
5	Modification of the Positive Mold	You should be able to modify the positive mold for pressure sensitive areas.	<p>You will be able to:</p> <ul style="list-style-type: none"> • Establishing general trim lines • Evaluate and record AP and ML dimensions • Compare cast measurements to anatomical • Remove plaster form the model in areas where socket pressure is desired • Create plaster build-ups in areas where low socket pressure is required • Modify the supracondylar region
6	Materials Used in Plastic Lamination	After completing this module you will be able to create a soft liner to provide additional padding between the patient's limb and socket.	<p>You will be able to:</p> <ul style="list-style-type: none"> • Have an understanding of the purposes, advantages and disadvantages, and special considerations of a soft liner. • Be able to fabricate the distal padding • Be able to fabricate the soft liner • Be able to fabricate the soft liner for supracondylar suspension

TRANSFEMORAL PROSTHETICS MODULE SET			
Module Number	Module Title	Goals	Objectives
7	Lay Up and Plastic Lamination	After completing this section, you will know the various properties of materials that are used during the lamination process.	<p>You will be able to:</p> <ul style="list-style-type: none"> • Know the materials used in prosthetic lamination • Have an understanding of mixing chemicals for lamination materials • Have an understanding shelf life and safety for lamination materials • Have an understanding of lamination fabrics and principles
8	Bench Alignment	When you finish this module you will be able to use the lamination procedure described to create a light and durable prosthetic socket.	<p>You will be able to:</p> <ul style="list-style-type: none"> • Review basic materials and tools for creating a lay up • Be able to create the lay up • Review basic materials and tools for lamination • Work with plastic lamination

TRANSFEMORAL PROSTHETICS MODULE SET		
Module Number	Module Title	Objectives
9	<p>Suspension System</p> <p>At the end of this module you will be able to establish trim lines on a laminated socket, trim it and place it on an adjustable alignment system. You will also have an understanding of the Berkeley Adjustable Alignment Jig and the endoskeletal system.</p>	<p>You will be able to:</p> <ul style="list-style-type: none"> • Remove the prosthetic socket from the plaster mold • Establish the trim lines • Understand Berkeley Adjustable leg and endoskeletal alignment systems • Know flexion and adduction angles • Attach a prosthetic foot • Align the sagittal and coronal planes • Attach the socket to the alignment system
10	<p>Static Alignment</p> <p>When finishing this module you should be able to evaluate and properly adjust prosthetic suspension systems.</p>	<p>You will be able to:</p> <ul style="list-style-type: none"> • Have an understanding of the purpose of the suspension systems • Know the parts of the cuff suspension strap • Know the forms of the suspension systems

TRANSFEMORAL PROSTHETICS MODULE SET		
Module Number	Module Title	Goals Objectives
11	Gait Terminology and Dynamic Alignment	<p>After completing this section, you will be able to evaluate and properly perform dynamic prosthetic alignment.</p> <p>You will be able to:</p> <ul style="list-style-type: none"> • Have an understanding of gait deviations • Understand the human walking cycle • Understand heel compression • Make and show evaluations • Compare normal gait and gait deviations • Know the causes and solutions of gait deviations

CENTER FOR INTERNATIONAL REHABILITATION
Annual Report to the Department of Defense
#DAMD17-00-1-0711

APPENDIX G

List of Distance Learning Training Centers

Center	Address (City, Country)
Bosnia	
ORTO SAR	Zmaja od Bosne, Sarajevo, BiH
Centar za rehabilitaciju/Reumal	Bolnicka 1, Fojnica, BiH
Kantonalna bolnica/Odjel za rehabilitaciju amputiraca, proteze i ortoze	Bulevar Kralja Tvrtka 1 br. 34 Zenica, BiH
Ortopedska radionica HVIDRA	Josipa Plavicica Bjokac bb, Vitez, BiH
Ortopedija La_va	Sehidska 17 a, Travnik, BiH
MED/REHA	U krugu Incela, Banja Luka, BiH
Nova ortopedija	Moravska 78, Banja Luka, BiH
Zavod za ortopedsku protetiku	Slatinska 11, Banja Luka, BiH
Medicus Matea	Midic Mahal 133, Bihac, BiH
Klini_ka bolnica/ Odjel za izradu	Kardinala Stepinca bb, Mostar, BiH
RNC Dr. Safet Muji_Ortopedska radionica	Sjeverni logor, Mostar, BiH
Tuzla	
Zavod za protetiku Tuzla	Trnovac bb, Tuzla
Slovenia	
Institute for Rehabilitation-Republic of Slovenia	Sjeverni logor, Slovenia
Nicaragua	
CENAPRORTO	Centro Nacional de Produccion de Ayudas Tecnica y Elementos Ortoprotesicos Managua
Trinidad Workshop – Handicap International	Esteli, La Trinidad
Walking Unidos -	Leon, Nicaragua
El Salvador	
CERPROFA	Centro de Rehabilitacion Professional de las Fuerzas Armadas San Salvador, El Salvador
FUNTER	Fundacion Teleton Pro-Rehabilitation Ciudad Merliot, El Salvador
ISRI	Instituto Salvadoreno de Rehabilitacion de Invalidos San Salvador, El Salvador
ISRI	Centro de Rehabilitacion de Oriente (ISRI) San Miguel, El Salvador
PODES	Promotora de la Organizacion de Discapacitados de El Salvador San Salvador, El Salvado
Guatemala	
AGREL	Asociacion Guatemalteca de Rehabilitacion Ciudad de Guatemala, Guatemala
CADEG	Centro de Atencion a Discapacitados del Ejercito de Guatemala Ciudad Guatemala, Guatemala

IGSS	Instituto Guatemalteco de Seguridad Social Ciudad de Guatemala, Guatemala
Hospital de Infantil de Infectología y Rehabilitación	Ciudad de Guatemala, Guatemala
Fundación Pediátrica Guatemalteca	Ciudad de Guatemala, Guatemala
<i>Honduras</i>	
Hospital San Felipe	Tegucigalpa, Honduras
Teletón Honduras, Regional San Pedro Sula	San Pedro Sula, Honduras
Central America Medical Outreach (CAMO)	San Pedro Sula, Honduras

CENTER FOR INTERNATIONAL REHABILITATION
Annual Report to the Department of Defense
#DAMD17-00-1-0711

APPENDIX H

Sample modules from new module sets
Transhumeral Prosthetics Module Set
CIR Casting System Module Set
Ischial Containment Module Set



Transhumeral Prosthetics Module Set

X. Trimming, Assembly and Harnessing



Northwestern University Prosthetics Orthotics Center

This work was funded in part by the National Institute on Disability and Rehabilitation Research of the U. S. Department of Education under grant number H133E980031 and by the Department of Defense under award number DAMD17-00-1-0711.

© 2003 Center for International Rehabilitation

Statement of Purpose

This module is designed to teach principles involved in the fabrication of a transhumeral prosthesis.

It is part of a series of modules developed by the Center for International Rehabilitation with assistance from Northwestern University Prosthetics Orthotics Center and the support of the National Institute on Disability and Rehabilitation Research of the U.S. Department of Education.

Module Objectives and Goals

Goal - After completing this module the learner should be able to trim, assemble, harness and evaluate the transhumeral prosthesis.

Objectives - The learner will:

- Identify the various components, their purpose and their location on the prosthesis
- Be able to fit a body powered transhumeral amputee using a positive locking elbow and a figure-of-eight harnessing
- Perform a final evaluation of the patient to evaluate cosmetic appearance and maximize function

Introduction

The following module describes the assembly procedures for finishing the transhumeral prosthesis. Description will be provided of the components and their purposes and locations. This material will also take the prosthetist through the harnessing and final fitting considerations for the transhumeral amputee using a positive locking elbow and figure-of-eight harnessing.

Cabling System



Cable Assembly

Trimming

Once the resin of the final lamination has fully cured, you can break out the plaster and grind the interface until the trim lines are established. The axilla area should be flat to help prevent rotation of the prosthesis while the patient is operating the cable. The humeral section will be hollow, therefore the foam or plaster of Paris material added to give the shape will now be removed. Once the humeral section is hollow, the elbow assembly can be connected to the humeral section.

Assembly

If a Hosmer elbow is utilized, push the elbow bolt through the hole in the turntable to the inside of the humeral section. Then, two Belleville spring washers will be placed in a convex orientation over the bolt. Next, tighten the crown nut that holds the elbow unit to the humeral section until snug. The tightness will effect the ease of forearm rotation.

Assembly

You are now ready to assemble the cable and housing assembly.

Terminal Device

A triple swivel will require swaging on the distal end of the cable. The triple swivel will be the cable's distal attachment point at the terminal device.



Triple swivel

Terminal Device

Place the swage in the vice and insert the cable at the proper position for its size. The swage will usually have small, medium, and large cable positions. Use a medium cable for average use and a large cable for heavy-duty use.

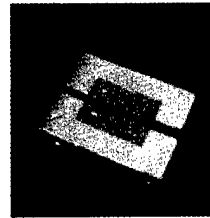

Swaging tool

Terminal Device

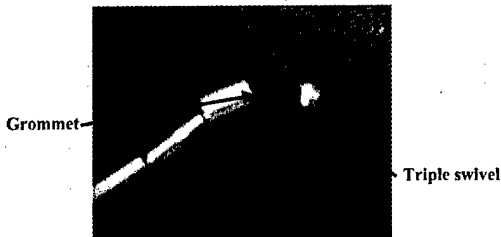

Triple swivel and grommet

Swage the triple swivel and then add a grommet. The grommet prevents the cable from popping out of the TD.

Assembly



Insert the terminal device into the wrist unit. There should be a few threads of the TD remaining to allow for pronation and supination. If a constant friction wrist unit is utilized then the friction screw must be loosened prior to inserting the TD to prevent stripping on the threads. Once the TD is inserted, tighten the friction to prevent unwanted rotation while pulling on the cable to open the TD. Attach the cable to the terminal device with the triple swivel.

Assembly

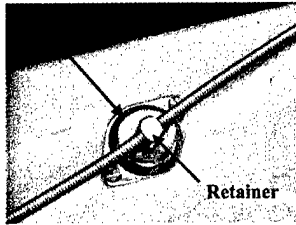

Base plate and retainer

A base plate and retainer serve as the anchor point for the cable housing upon the humeral section.

Assembly

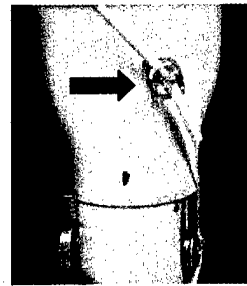

Placement of base plate and retainer

The base plate should be positioned on the posterior lateral aspect of the socket approximately 25mm proximal to the cut end of the humerus. It should never be placed below the distal end of the humerus or the result will be the end of the cut bone becoming the reaction point.

Assembly

Note: If the patient has a short residual limb place the base plate a little more posterior in order to capture more motion (excursion) of the scapula. With a longer residual limb the base plate may be found a little more lateral.

Assembly

Elbow Flexion Attachment Jig

The use of an elbow flexion attachment jig during the fitting process is recommended to allow the prosthetist to find the ideal location for attaching the cable housing to the forearm. The elbow flexion attachment jig is a device that can be used for either a left or the right prosthesis and is attached on the lateral side of the forearm near the elbow.

Assembly

Elbow Flexion Attachment Tab
An elbow flexion attachment tab, usually made of leather or plastic, will hold the cable housing 25 mm (1") anterior and 30 mm (1") distal to the elbow center for a starting position. The elbow flexion attachment tab may be moved proximally or distally during the fitting to effect the force/excursion relationship required for lifting the forearm.

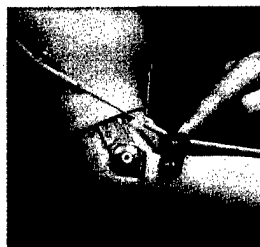

Elbow flexion attachment tab

Assembly

Elbow Flexion Attachment Tab

The prosthetist will drill a 6 mm (1/4") hole 28 mm (1 1/8") away from the center of the cable housing into the elbow flexion attachment tab. Since the bottom hole is offset from the elbow center by 3 mm this will result in the cable housing being in the desired position of 25 mm anterior of the elbow center. Insert an aluminum bushing into this hole, it will allow the tab to swivel with forearm movement.

Assembly

Elbow Flexion Attachment Tab

Attach the elbow flexion attachment tab into the third hole from the top using the provided screw. This location results in the elbow flexion attachment tab being 30 mm distal to the elbow center.

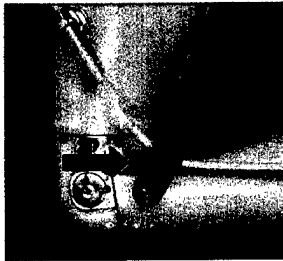

Elbow attachment tab

Assembly



Determining the length of the distal cable housing
Supinate and open the TD, mark the location of the proximal end of the triple swivel onto the forearm and allow an extra 3 mm for the ferrule. This will determine the maximum length of the distal housing. Leave no more than 12 mm of housing proximal to the elbow flexion attachment assembly.

Assembly

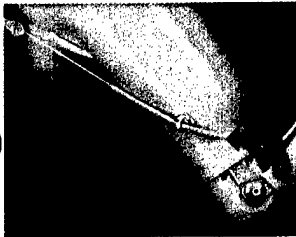

Determining the length of the proximal cable housing
The initial (maximum) proximal cable housing length will extend from the axilla to the turntable. This initial length is a maximum length and will likely require shortening as the patient is fitted to avoid having the cable exposed on the patient's back while opening the TD with full elbow flexion. Insert the proximal housing into the retainer.

Assembly

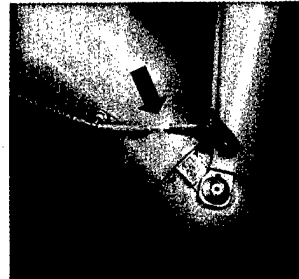

With both the distal and proximal housings in place, insert the cable into the housing and bring the forearm into full flexion. With tension applied to the cable, leave 6 mm (1/4") of cable between the two lengths of housings.

Assembly

Evaluate for 3 mm (1/8") clearance between the distal housing and the triple swivel assembly with the elbow fully flexed and the TD both opened and supinated.

Assembly

With the elbow fully extended and the TD pronated, leave 6 mm of clearance and attach the adjustable hanger onto the cable above the proximal housing.

Initial Patient Fitting

Once the previous components have been fabricated and attached in the proper locations, you are ready to gather your materials for making the figure of eight harness. The harness for the transhumeral is best if it is custom made, though a premade figure of eight with a Northwestern Ring may be utilized on the transhumeral amputee who presents with a long residual limb and good range of motion and muscle strength.

The figure of eight harness without the ring captures more scapular excursion to result in an increase in functionality of the prosthesis (i.e. greater opening of the TD with full elbow flexion).

Initial Patient Fitting

Harness materials:

1" Dacron webbing 60" in length

1" elastic 12" in length

1/2 " Dacron webbing 15" in length

1- 2 prong buckle with tab

1- 4 bar buckle with tab

1- 4 bar buckle

1"- 2 prong buckle with tab for the elbow lock

Axilla pad (plastic coating for the Dacron that goes under the axilla)

Initial Patient Fitting

The 15" elastic webbing (for the elastic portion of the anterior suspension strap) will be sewn to the end of the 60" Dacron webbing.

The 1/2" Dacron webbing will be sewn to the front of this same assembly with the 1" buckle attached and facing downward. (The 1/2" Dacron webbing will insert into the elbow lock hanger and loop back into the buckle once its length is found on the patient.)

Apply the axilla pad to the other side of the 60" Dacron piece.

Initial Patient Fitting

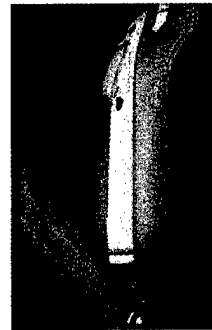

Attaching the two prong buckle with tab to the anterior medial aspect of the humeral section. To find the exact location, orient the prosthesis and forearm so that there is slight internal rotation of the forearm section.

Initial Patient Fitting



Elbow lock

Note the position of the elbow lock cable and housing as it exits the elbow unit and would point toward the deltopectoral groove. Attach the buckle so that it is just proximal to the turntable and so that it will not interfere with the elbow lock cable and housing.

Initial Patient Fitting

You are now ready to place the prosthesis on the patient and begin the procedure for fabricating a custom figure of eight harness.

Initial Patient Fitting

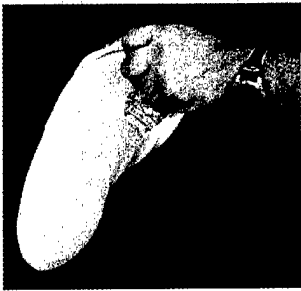

Patient applying prosthetic sock

Apply a prosthetic sock over the patient's skin and don the prosthesis. Check for range of motion and comfort. Make any necessary changes, though none should be expected at this point, because all corrections should have been made during the fitting of the check socket.

Attaching a Figure-of-Eight Harness

Begin harnessing by positioning the anterior suspension strap in the deltopectoral groove. The elastic portion should begin just inferior to the clavicle.

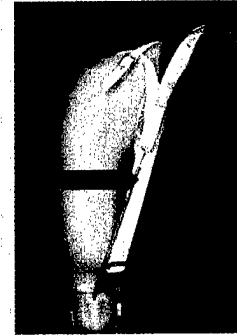

Anterior suspension strap

Attaching a Figure-of-Eight Harness

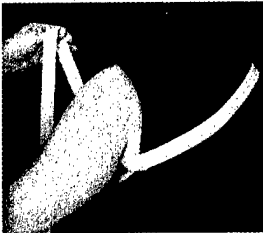

Contralateral axilla

Keep the anterior suspension strap snug in the deltopectoral groove while firmly pulling the Dacron webbing through and into the contralateral axilla. Have the patient raise and readjust his arm for comfort to ensure the axilla loop is snug. If you fail to make the axilla loop snug, the harness will continue to shift as you make complete the figure of eight and you will have to start over again.

Attaching a Figure-of-Eight Harness

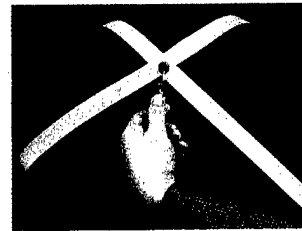

Adjust the plastic for the axilla loop as needed, but ensure the loop is tight. As the Dacron webbing exits the axilla, pull it tightly through the deltopectoral groove and form a cross point on the patient's back. The cross point should begin about 25 mm (1") toward the non-amputated side and inferior to the 7th cervical vertebra. Clamp into place.

Attaching a Figure-of-Eight Harness



With the remaining loose Dacron webbing, the control attachment strap will be formed. Place the webbing through the hanger, reverse it onto itself, and clamp it into place with tension on the cable. A four bar buckle will be placed close to the cross point to allow for attaching and adjusting the control attachment strap.

Attaching a Figure-of-Eight Harness

Now you will make a lateral suspension strap. The lateral suspension strap is the main suspensor of the prosthesis. Its job is to hold the prosthesis onto the shoulder and prevent movement when a downward pull is applied.



Lateral suspension strap

Attaching a Figure-of-Eight Harness

The lateral suspension strap will cross the apex of the shoulder and fasten onto the proximal aspect of the socket, just anterior to the lateral midline. It is placed just anterior to the lateral midpoint to help prevent external rotation of the prosthesis when body motions are executed.

Mark the position of the lateral suspension strap by drawing a pencil line on either side of the strap. A four bar buckle with tab will be riveted into place here to hold lateral suspension strap and allow for adjustment in the tension.

Attaching a Figure-of-Eight Harness

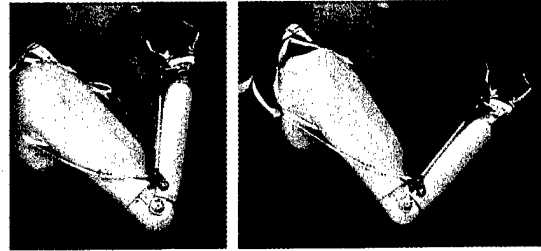

Once the lateral suspension strap is attached and snug. You are ready to have the harness "fit itself". This means that you will help the patient go through the motions of operating the prosthesis while you watch the movements of the harness.

Attaching a Figure-of-Eight Harness

Place your hand under the control attachment strap and hold it tightly between your fingers and thumb. Ask the patient to use body motion (glenohumeral flexion) to raise the forearm. Once he relaxes again, look at the intersection points of the harness. Loosen the Yates clamps and let the straps find a new position. Re-clamp and repeat the procedure until there is no longer tension at the intersection of the straps.

Attaching a Figure-of-Eight Harness

Now you will manually lock the elbow at full flexion. Place your hand under the control attachment strap and ask the patient to open the terminal device by using body motions. Once the patient has relaxed, readjust the intersection tension of the harness straps as before.



Adjusting the figure-of-eight harness

Attaching a Figure-of-Eight Harness

Note: Once you are satisfied with this, take another look at where each strap is located. If your harness was not initially tight enough, you may find the migration is now unacceptable. If this is the case, start over with the harnessing procedures. The need to start over will be common until you are well experienced. Do not skip making it correct.

Attaching a Figure-of-Eight Harness

Once all the straps are in the correct positions anatomically and the harness lays flat against the person's back during operating of the prosthesis, you are ready to prepare to sew the harness.

Attaching a Figure-of-Eight Harness

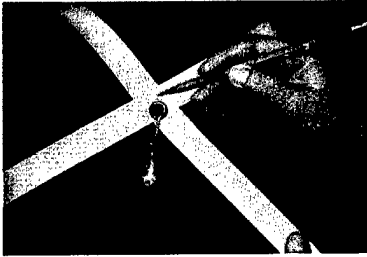

Mark the intersection of every strap lightly with a pencil. A pencil is used because the marks may be removed once they are no longer needed. Remove the prosthesis from the patient. Keep the Yates clamps on at this point, yet unfasten the lateral suspension strap and the anterior suspension strap.

Attaching a Figure-of-Eight Harness

While maintaining the position of each strap sew the harness.

Fitting and Harnessing

Re-attach the harness to the prosthesis and the patient. Adjust the tightness of each strap and be mindful of the position of each strap both anatomically and functionally. Remember that as you adjust one strap it will effect others. Constantly evaluate and adjust.

Tighten the control attachment strap so that the forearm would lift with the slightest exertion. It should be snug enough that no body motion is lost.

Fitting and Harnessing

A starting value for the number of rubber bands is three. If you notice the terminal device is opening while the amputee is raising the forearm it means that it is requiring more force to raise the forearm than what it does to open the terminal device.

Fitting and Harnessing

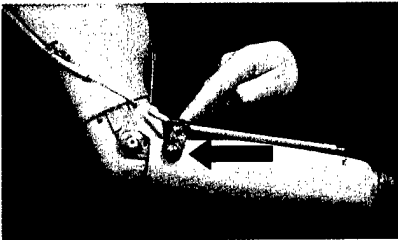

To decrease the force required to raise the forearm move the elbow flexion attachment tab distally. Be aware however, that this will result in an increase in the amount of excursion required to raise the forearm.

Fitting and Harnessing

Moving the base plate and retainer more posterior will increase the efficiency by giving a straighter line of pull and increase the amount of excursion available since it will cause the control attachment strap to lie more inferior on the scapula.

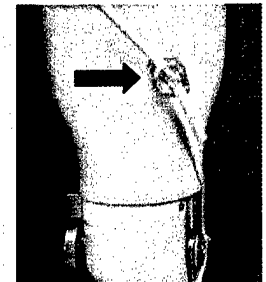

Placement of base plate and retainer

Fitting and Harnessing

Ask the patient to open the terminal device at his mouth. If you need to increase the opening you may:

- Move the proximal retainer more posterior
- Move the proximal retainer more distal (but not below the cut end of the bone)
- Move the elbow flexion attachment point more proximal
- Tighten the control attachment strap (beware of tightening too much which will result in the TD opening before full elbow flexion is achieved)

Fitting and Harnessing

It is now time to attach the elbow lock strap. Lock and unlock the elbow a few times to make the patient aware of the auditory clues of locking and unlocking. Take the patient through the body motions required for elbow lock operation.

These movements include a combination of glenohumeral abduction, glenohumeral extension and shoulder depression

Fitting and Harnessing

To attach the elbow lock strap, place the 1/2" Dacron webbing down through the hanger and back again. To find the proper tension of this strap lift up on the strap to pull the hanger until you hear the click of the elbow. Loosen it slightly until you hear the second click, maintain this exact tension while placing the end of the strap through the buckle.



Attaching the elbow lock strap

Fitting and Harnessing

Have the patient practice operating the elbow lock a few times. The motion takes practice. If you notice the anterior suspension strap gets caught underneath the edge of the socket near the deltopectoral groove (this is more likely to occur with more medial trim lines as found on someone with a short residual limb), you may need to add a loop strap onto the socket to hold it in place.

Fitting and Harnessing

At this point, you will want to ask the patient to raise and lower the forearm, open and close the hook and lock and unlock the elbow lock. As the person goes through these procedures you will want to make adjustments to make the smoothest, easiest operation.

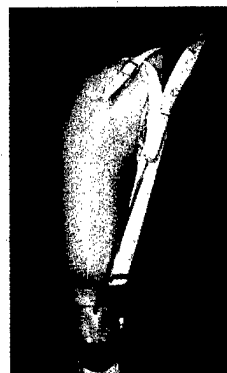

Fitting and Harnessing

The following are some hints, guidelines and solutions for troubleshooting.

Fitting and Harnessing

Cross Back Strap

A cross back strap is a strap that goes from the control attachment strap, through the hanger and attaches onto the distal side of contralateral axilla strap. The cross back strap greatly increases excursion. It will cause donning to be more difficult if the person uses the "over the head" method.



Cross back strap

Fitting and Harnessing

To increase the excursion available:

- Move retainer more posterior
- Move retainer more distal (limit is the end of the humerus)
- Move the elbow flexion more proximal
- Add or tighten the cross back strap

Fitting and Harnessing

Using a shorter forearm, a lighter terminal device and a teflon liner to the housing will all make operating the prosthesis easier.

Fitting and Harnessing

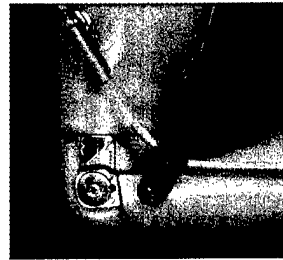

Elbow attachment tab

The perpendicular distance between the cable and the elbow center affects the amount of force required to raise the forearm. The smaller the distance, the easier the operation.

To decrease the force required to raise the forearm:
Move retainer toward the anterior
Move the elbow flexion more distal

Fitting and Harnessing

Socket displacement should be evaluated. Pull down on the prosthesis and note any migration of the prosthesis. Any more movement than 12 mm (1/2") requires an adjustment to tighten the lateral suspension strap.

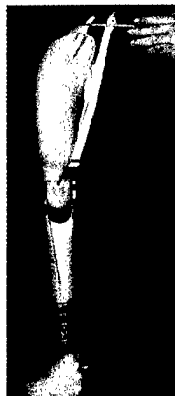

Fitting and Harnessing

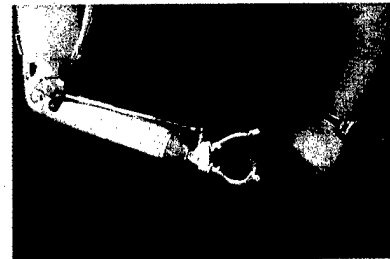

To allow the person to operate the terminal device at his waist, internally rotate the prosthesis. The tightness of the turntable should allow the person to reposition the forearm without having it rotate unintentionally.

Fitting and Harnessing

To increase the opening of the TD at the mouth:

- Tighten the control attachment strap
- Move the elbow flexion attachment tab proximal
(You may need to add a spring lift assist to help raise the forearm)
- Move base plate and retainer posterior and distal (not past end of humerus)
- Training
- Evaluate position of cross point and re-harness if not toward contralateral side
- Evaluate number of rubber bands and decrease if necessary

Fitting and Harnessing

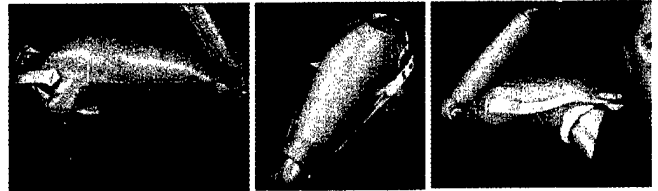

Flexion

Extension

Abduction

Range of Motion with the Prosthesis:

- Glenohumeral flexion 90 degrees
- Glenohumeral extension 30 degrees
- Glenohumeral abduction 90 degrees

Fitting and Harnessing



Glenohumeral flexion

The glenohumeral flexion required to raise the forearm should not exceed 45 degrees. If you measure an excess on your patient then evaluate the snugness of the control attachment strap and socket looseness.

Fitting the Prosthesis

If the terminal device uses rubber bands, the number of bands applied should be discussed with the patient, with respect to the pinch force offered and the increasing difficulty of operation with each additional band.

Fitting the Prosthesis



Rubber bands

Three bands is a reasonable starting point for a new patient. If the person is a heavy-duty user, more bands may be applied to increase the available pinch force. Rubber bands may be cut in half if adding a whole one is too much. If springs are used for tension, they should be evaluated in the same manner.

Fitting the Prosthesis

Additional bands should be given to the patient, along with instructions on how to apply them.

Final Touches

The prosthesis should be evaluated for length and general cosmetic appearance.

Once the prosthesis is totally satisfactory to both the amputee and the prosthetist in function, performance, and cosmetic quality, finishing touches will be applied.

Final Touches

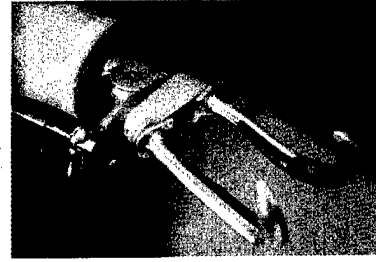

To determine the distal cable housing length, fully flex the elbow, supinate the hook and open it fully while applying tension on the cable. There should be 3mm clearance between the proximal edge of the triple swivel and the distal edge of the housing. Adjust until corrected.

Final Touches

To determine the distance between the distal and proximal cable housing length fully flex the elbow, while applying tension on the cable. There should be 6 mm clearance between one and the other. Adjust until corrected and apply ferrules.

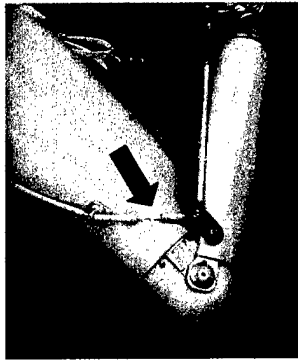

Final Touches

To establish the proximal cable housing length, extend the elbow, pronate the terminal device, trim the housing to as little as 12mm proximal to the base plate assembly. Be sure to remove the cable before cutting the housing!

Apply a ferrule to both the proximal and distal ends of the housing.

Final Touches

While the cable is removed from the housing, it is useful to apply door wax for lubrication. This will increase the efficiency of the system and make the operation of the terminal device a little easier.

Final Touches

To find the maximum cable length necessary, pronate the terminal device with the elbow extended. Slide the adjustable hanger to 12mm away from the proximal housing edge. This will allow room for the ferrules and the permanent hanger.

Apply the permanent hanger by swaging it to the proximal end of the cable.

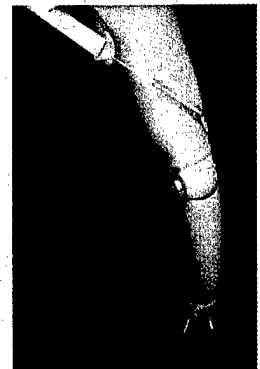

Final Touches

It is helpful to cut all the loose ends of the harness on an angle to help insert them through the buckles. Once the ends are cut, burn the ends of the Dacron webbing to prevent the material from unraveling.

Final Prosthesis Evaluation

At this time, it is useful to implement training in order to teach the person body motions and substitute methods for performing the activities of daily living. An occupational therapist should be present if possible.

Meeting, talking with, and watching another amputee who is experienced with the use of an upper-limb transradial prosthesis can be invaluable to a new amputee. It is particularly helpful for a bilateral amputee to meet other individuals with bilateral upper-limb loss.

Conclusion

Once all the finishing laboratory work has been completed, return the prosthesis to the patient and do a final evaluation of the prosthesis. The prosthesis should be cosmetic in appearance; be comfortable in all positions and during operation; and the patient should be able to raise and lower the forearm, open and close the terminal device, and lock and unlock the elbow.



CIR Casting System Module Set

Module 2: CIR Casting Station assembly



Northwestern University
Prosthetics-Orthotics Center

This work was funded in part by the National Institute on Disability and Rehabilitation Research of the U. S. Department of Education under grant number H133E980031 and by the Department of Defense under award number DAMD17-00-1-0711.

© 2003 Center for International Rehabilitation

Statement of Purpose

This module details the parts, tools, and step-by-step instructions for assembling the CIR Casting Station.

It is part of a series of modules developed by the Center for International Rehabilitation with assistance from Northwestern University Prosthetics/Orthotics Center and support of the National Institute on Disability and Rehabilitation Research of the U.S. Department of Education.

Module Goals and Objectives

Goal

The goal of this module is to provide the learner with all the necessary descriptions of parts, tools and process for the proper assembly of the CIR Casting Station.

Objectives

Upon completion of this module the learner will be able to:

1. Locate or purchase all the parts and tools necessary for assembly of the CIR Casting Station.
2. Follow the step-by-step assembly instructions resulting in a complete CIR Casting Station.

Introduction

The CIR Casting Station assembly can be completed with a simple set of tools and the proper materials. Whether the reader is assembling a CIR Casting Station kit or starting with only the list of parts in this module, the materials and skills needed for assembly are, by design, within the capabilities of most adults.

Note: The materials used in this presentation are available from hardware stores and manufacturers in the United States, though similar supplies can be found in any part of the world and used as alternatives to the materials referenced in this presentation.

CIR Casting Station

The CIR Casting Station consists of two main parts, a sand container and a platform. The sand container is the essential part because it can be used with or without the platform for prosthetic socket casting.

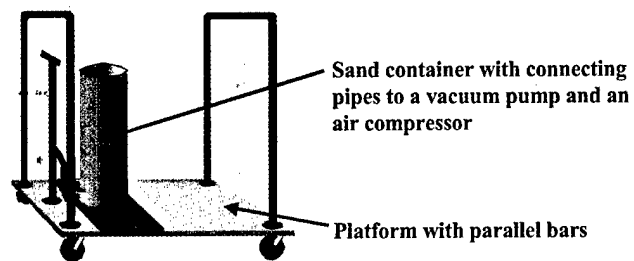

Main parts of the CIR Casting Station

Sand container: Component parts



The sand container is made of a *PVC drainage pipe* (8 inches in diameter and 24 inches long¹) and a *container base*, which consists of a *wooden base* and an *air pipe unit*.

1. All measurements provided in this module can be converted to the metric units, as appropriate to the materials used in the region of assembly.

Sand container- Design

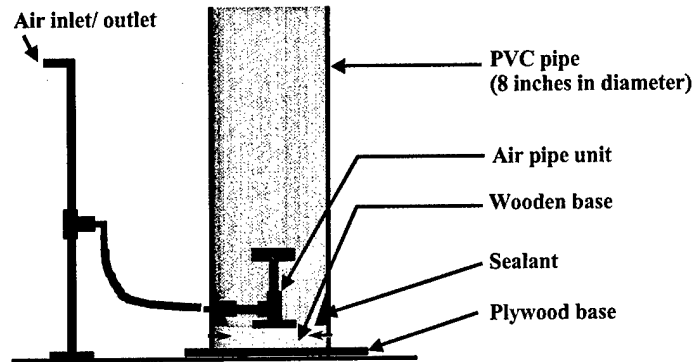

Assembled sand container with wooden base inside the PVC pipe and plywood base underneath the PVC pipe.

Sand container: Air pipe unit parts list

Use the pipe sealing tape and pliers to secure connections of the air pipe unit parts.

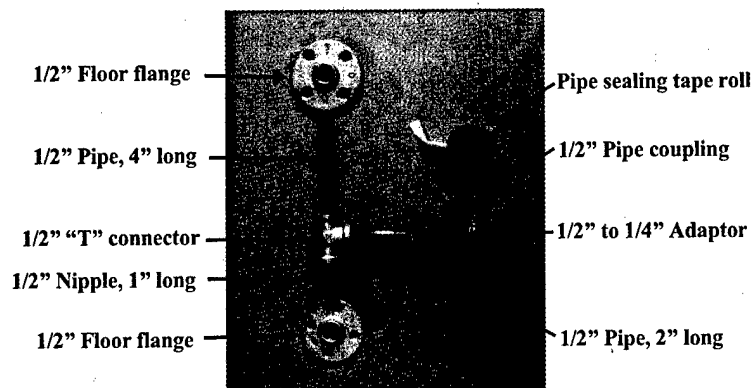

Air pipe unit parts

Sand container: Air pipe unit

The assembled air pipe unit should look like the image at right.

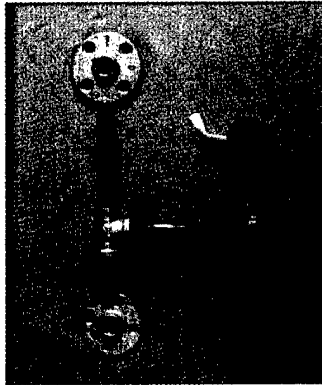

Air pipe unit parts

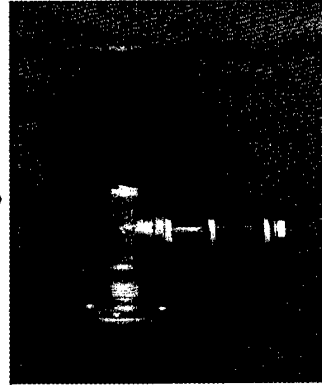

Assembled air pipe unit

Sand container: Wooden base

Cut a 2" thick wooden board that will fit flush inside the PVC pipe.

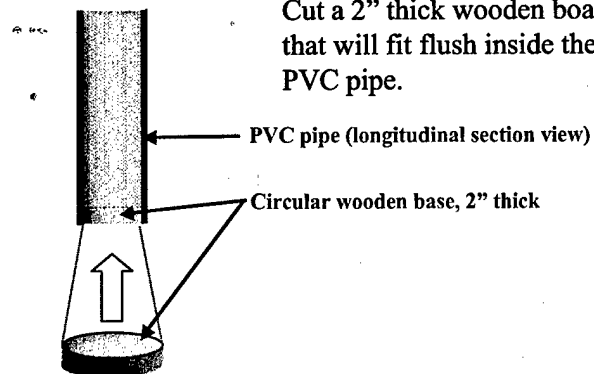

Sand container: Container base unit

Using the predrilled holes in the floor flanges, secure with four screws the *air pipe unit* to the center of *wooden base* to form the *container base unit*.

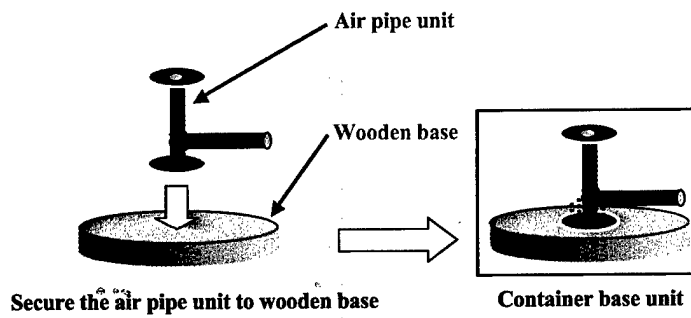

Sand container: Container base unit

Apply a canvas cloth or a 5-ply wool sock over the floor flange and secure with electric tape to the pipe underneath. This will be used as a sand filter.

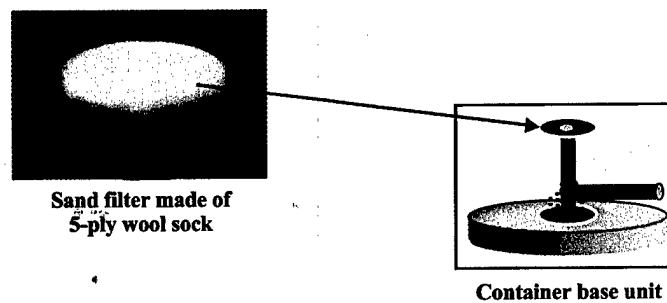

Sand container: Marking the PVC pipe

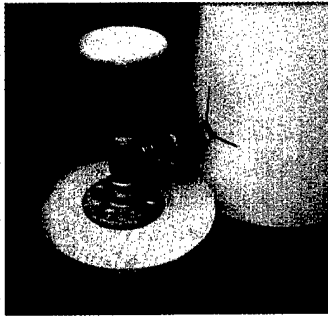

Location for marking
the center of the air pipe unit

Place the container base unit next to the PVC pipe. Mark the PVC pipe at a spot that matches the center of air pipe unit. Drill a 7/8" hole at the center.

Sand container: Drilling into the PVC pipe

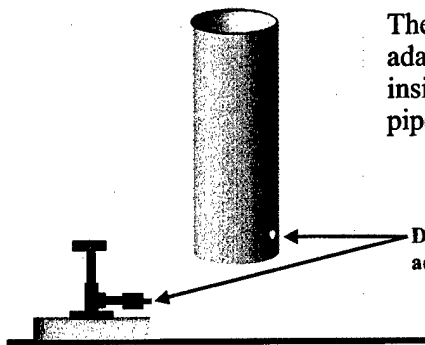

The 7/8" hole allows the pipe adaptor to protrude from the inside to the outside of the PVC pipe.

Drilled hole in PVC pipe for the pipe adaptor section of the air pipe unit.

Sand container: Container base unit inside the PVC pipe



Position the PVC pipe onto the container base unit

Now, position the PVC pipe onto the container base with the hole matching the air outlet of the container base unit.

Side view



Longitudinal section view

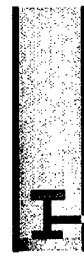

The container base unit is positioned inside the bottom of PVC pipe

Sand container: Securing the PVC pipe to its base

Secure the PVC pipe to its container base with screws inserted through the pipe and into the wooden base.

Side view



Screws

Longitudinal section view

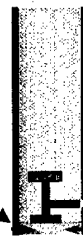

PVC pipe secured to its base with screws

Sand container: Connecting the air hose

Connect the air hose connector to the air pipe unit.

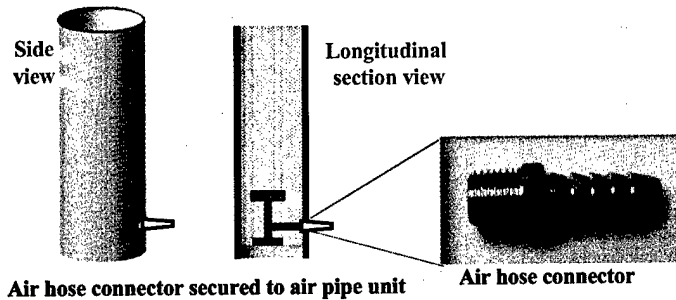

Sand container: Sealing

Seal the gaps by applying silicon sealer (or similar alternative, such as polyurethane) between the wooden base of the container base unit and the PVC pipe to eliminate air leakage. Likewise, seal the area around air hose connector. The sand container is now fully assembled.

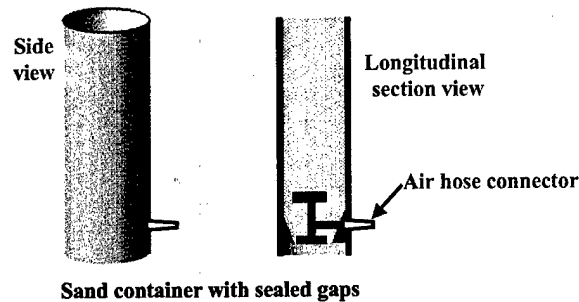

Sand container: Completed unit

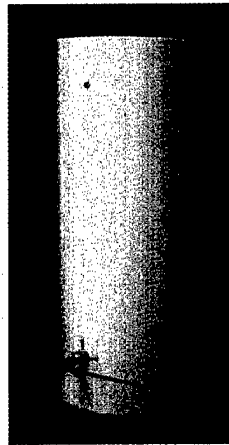

The left image is a completed sand container with an air hose connected to the air inlet/outlet assembly. The image below is a top view inside the sand container showing the sand filter in the center.

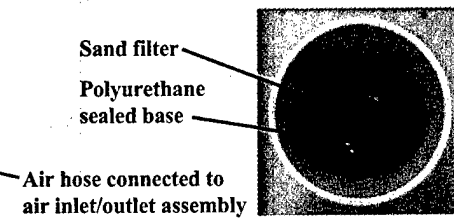

Sand filter

Polyurethane
sealed base

Air hose connected to
air inlet/outlet assembly

Casting platform

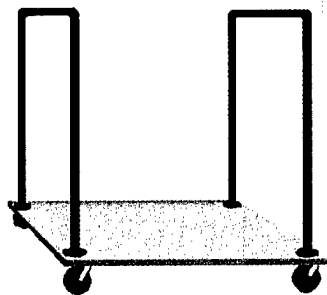

The second part of the CIR Casting Station is a wheeled platform with parallel bars.

Casting platform

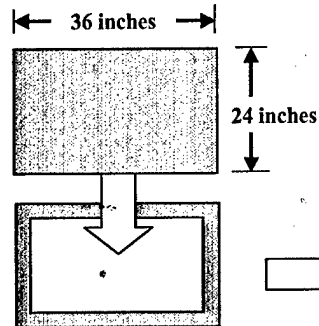

Attaching the plywood board to the wooden frame

A wooden frame should be constructed which will increase the strength of the platform and allow for attachment of the wheels. Glue and fasten a 3/4" thick plywood board (24" x 36") to the wooden frame (made of 2" x 4" studs) with screws to form the platform.

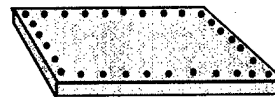

Wooden frame with attached plywood board

Casting platform

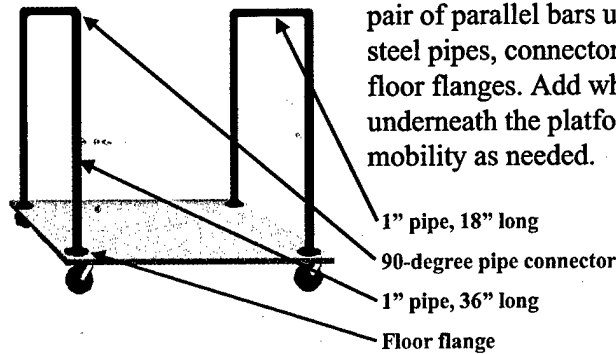

On the platform, install a pair of parallel bars using 1" steel pipes, connectors and floor flanges. Add wheels underneath the platform for mobility as needed.

1" pipe, 18" long

90-degree pipe connector

1" pipe, 36" long

Floor flange

Casting platform

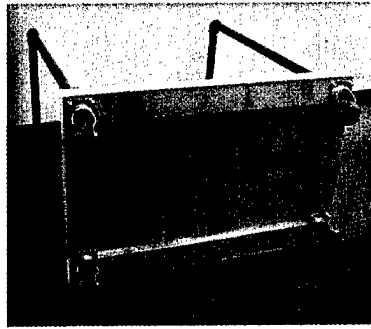

This is the bottom view of the platform with attached wheels. The attached wheels should be heavy duty (i.e., able to bear weight of at least a 300 pound individual). At least two of the four wheels should have a brake mechanism for safety.

CIR Casting Station: Air inlet and outlet assembly

Use the pipe sealing tape and pliers to secure connections of the air inlet/outlet assembly.

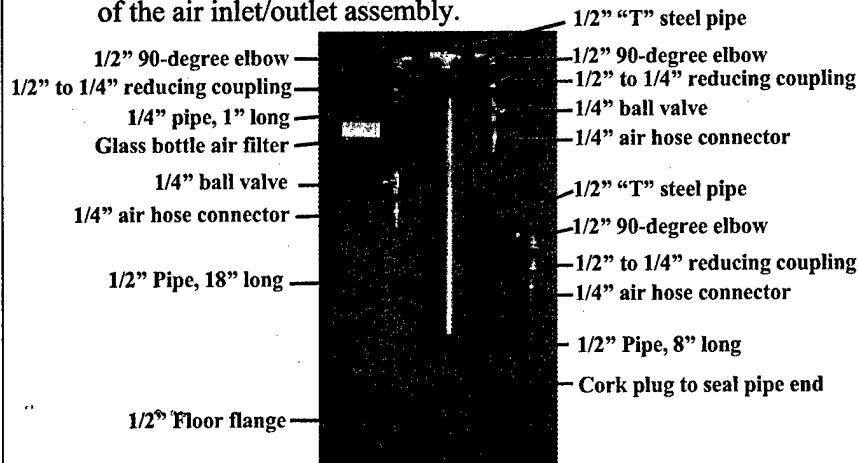

- 1/2" 90-degree elbow
- 1/2" to 1/4" reducing coupling
- 1/4" pipe, 1" long
- Glass bottle air filter
- 1/4" ball valve
- 1/4" air hose connector
- 1/2" Pipe, 18" long
- 1/2" Floor flange
- 1/2" "T" steel pipe
- 1/2" 90-degree elbow
- 1/2" to 1/4" reducing coupling
- 1/4" ball valve
- 1/4" air hose connector
- 1/2" "T" steel pipe
- 1/2" 90-degree elbow
- 1/2" to 1/4" reducing coupling
- 1/4" air hose connector
- 1/2" Pipe, 8" long
- Cork plug to seal pipe end

Air inlet/outlet assembly parts

CIR Casting Station: Air inlet and outlet assembly

Complete the air inlet/outlet assembly and connect the air hose (shown in red line) to the sand container.

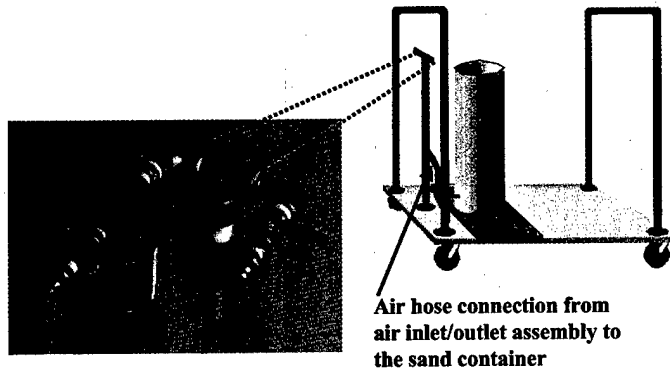

CIR Casting Station

Secure the container to the plywood base (12 by 24 inches) from below with wood screws. Then place the sand container with plywood base on the platform. Connect an air hose to the air hose connector at the container's base.

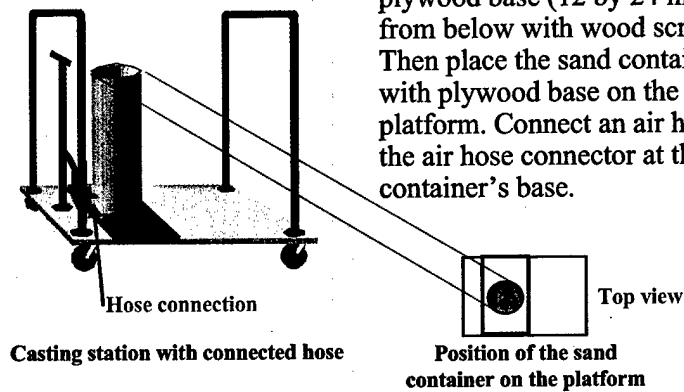

CIR Casting Station: Air inlet and outlet assembly

The assembled air pipe unit should look like the image at right.

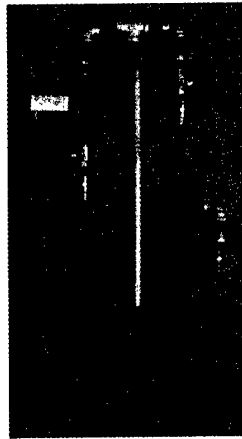

Inlet/outlet assembly parts

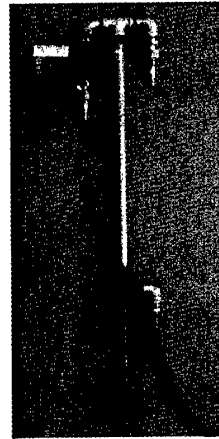

Assembled air inlet/outlet assembly

CIR Casting Station

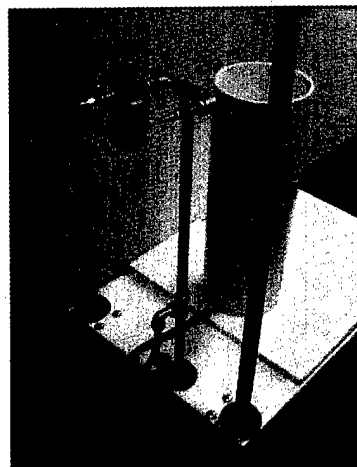

Secure the assembled air intake/outlet assembly to the platform of the casting station, connecting the air hose as shown at left.

The red arrow indicates the connection to the air compressor. The blue arrow indicates the connection to the vacuum pump.

CIR Casting Station

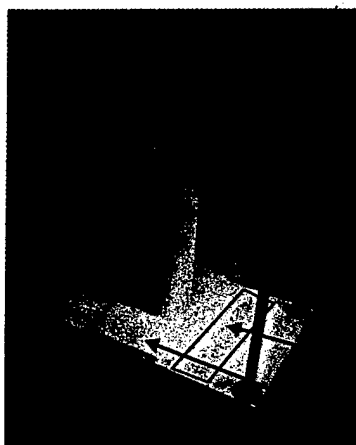

This is the assembled casting station.

For taller patients, the sand container can be raised by adding layers of plywood under the sand container. For shorter patients, layers of plywood can be placed under the sand leg.

Layers of plywood placed here for shorter patients

Plywood added under plywood base for taller patients

CIR Mandrel

An additional required piece of equipment is the CIR Mandrel, constructed using a 1/2" pipe (18" long) with a 1/4" air hose connector *welded* into one end of the pipe and a 1/2" pipe coupling screwed on to the other end.

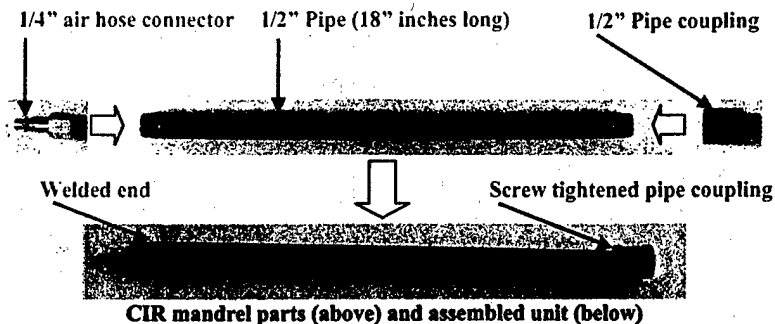

CIR Mandrel

Cover and tape a 5-ply wool sock to form a sand filter over the pipe coupling. The end of the mandrel with the air hose connector is then connected to the vacuum pump.

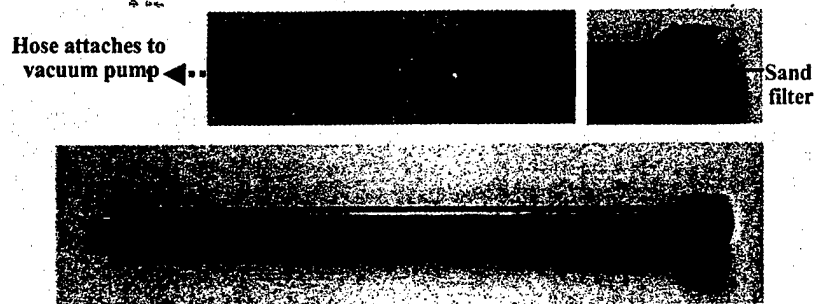

CIR mandrel with the sand filter covering the pipe coupling

Conclusion

If all the steps have been followed to this point, the CIR Casting System is now assembled and ready for additional equipment connections.

The next module in this module set details additional equipment specifications, set up and testing of the CIR Casting System.



Ischial Containment Module Set

III. Prosthetic Casting Techniques



Northwestern University Prosthetic Orthotic Center

This work was funded in part by the National Institute on Disability and Rehabilitation Research of the U. S. Department of Education under grant number H133E980031 and by the Department of Defense under award number DAMD17-00-1-0711.

© 2002 Center for International Rehabilitation

Module Objectives and Assignments

Add details here.

Casting

In the past, hand casts of the above-knee residual limb yielded models which were grossly oversized, therefore making it difficult for even the experienced prosthetist to modify.

The casting technique described herein yields a model which is much closer to the desired dimensions and captures the appropriate contours needed to meet the objectives of skeletal contour, muscle contour, and stability of the socket-limb interface.

Statement of Purpose

The goal is to accurately record the shape/volume relationship of the residual limb as well as the pertinent skeletal dimensions.

The casting is best performed by two people. In order to obtain the proper shape and volume it has proven successful to apply the cast in several stages using different types of plaster (synthetic casting material may be used in place of traditional elastic or fast setting plaster) to achieve the desired results.

Introduction

The following module focuses on patient prosthetic evaluation. It will help you evaluate the condition of the patient and the residual limb.

It is paramount that you not limit your evaluation to the residual limb. Rather, you should consider the *whole person* and how each aspect of this unique individual plays a role in selection of the appropriate prosthesis design.

Casting materials

- | | |
|--------------------------------|--------------------------|
| a. Patient Measurement Form | g. 4" Elastic Plaster |
| b. Indelible Pencil Ritz Stick | h. 4" Rigid Fast Plaster |
| c. A-P Calipers | i. 5" Rigid Fast Plaster |
| d. Tape Measure | j. Bucket |
| e. Casting Garment | k. Masking Tape |
| f. Cotton Pull Sock | |

Casting



1. Outline the lateral distal femur using indelible pencil. Mark any areas noted during the evaluation at this time.

Casting

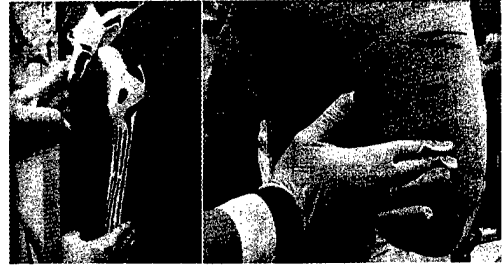

2. Practice the hand placement. By practicing the hand placement at this time, the practitioner may familiarize himself with the anatomical structures of the patient. It is much easier to palpate bony structures before applying the plaster wrap.

Casting

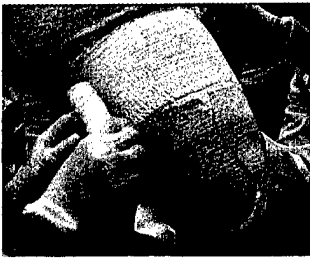

Lateral View

3. Wrap the residual limb is with elastic plaster beginning at ischial level and proceeding distally. Take care to not pull the adductor longus area laterally when applying the plaster.

Casting

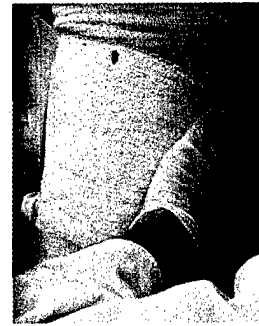

Anterior View

4. Apply fast setting (non-elastic) plaster over the elastic to act as reinforcement and to enable the prosthetist to better provide proper contours on the impression. Elastic plaster tends not to retain concave contours.

Casting



5. Apply a splint consisting of three layers of 5" fast setting plaster through the perineum extending at least 5" above perineal level anteriorly and posteriorly (a 20" splint is adequate for most patients). Pull the perineal splint up snugly to ensure contact with the pubic ramus. Pull the posterior aspect of the splint in a slight lateral direction in order to follow the ischio pubic ramus. Pull the anterior section straight up toward the umbilicus to prevent undo pressure on the adductor longus.

- It is important that the amputee only abduct the limb enough for the plaster to be applied.

Casting



Limb Position –

- Instruct the patient to adduct his limb.
 - The flexion attitude should be at a comfortably extended position.
7. Wrap five inch extra fast plaster around the entire pelvis at trochanteric level and firmly secure the wrap as it overlaps. The pelvic wrap is one layer thick. It is important to pull the pelvic wrap tight in order to achieve contact with the trochanter.
8. The cast is completed by plastering the entire hip area of the amputated side from anterior mid-line to posterior mid-line.

Casting



8. The cast is completed by plastering the entire hip area of the amputated side from anterior mid-line to posterior mid-line.

Casting



9. The casting procedure described uses two practitioners. The prosthetist behind the patient will place one hand firmly against the medial aspect of the ischium while applying a counter force over the trochanter. A goal during casting is to capture an accurate record of the distance between the ischium and the greater trochanter (M-L dimension). Maintain firm pressure against the medial aspect of the ischium until the plaster has set. Position the ischium so that it rests on the middle segment of the middle finger with the index finger on the medial aspect. Spread the 4th and 5th fingers as they compress the adductor tissues distal to the ischium. The deepest part of this depression should be 1 1/2 - 2 inches distal to ischial level. Ideally the tip of the index finger will be at the expected exit point of the ramus.

Casting



- If the pelvic wrap does not pull into the trochanter, you should indent the cast using one finger to achieve bony contact.

Casting

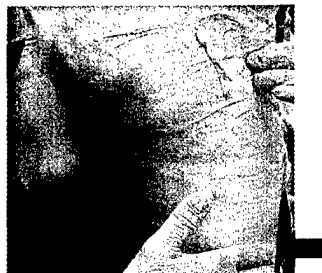

10. Instruct the patient to abduct his thigh slightly until you feel the distal femur move to the lateral soft tissue boundary. Resist any further motion of the femur by pressing against the lateral aspect with your hand flat against the cast. The base of your hand should be 1" proximal to the cut end of the femur and should give a slight flattening of the posterior lateral aspect of the cast extending proximally to your finger tips.

Casting



- As the amputee begins this abduction motion his adductors relax allowing your medially placed hand to sink into the adductors distal to the ischium as well as rendering the ischial tuberosity accessible to palpation. To achieve proper medial proximal contouring, *the relaxation of the adductors is crucial.*

Casting



11. The second practitioner who is positioned in front of the patient will mold in the area of the femoral triangle. This is done by massaging the plaster with emphasis at ischial level slightly lateral to the adductor longus. *Avoid applying pressure in the area of the anterior lateral aspect* as this may cause the ischium to be displaced medially in the completed socket, especially if the amputee has firm thigh musculature.

Casting

- If femoral internal rotation causes the anterior lateral aspect to become prominent, it is advisable to instruct the patient to internally rotate the thigh while the plaster is wet in order to ensure proper contour. Internally rotating the thigh will also produce a rectus channel of the depth required for proper anterior wall contouring.

Casting



12. Mark a line indicating line-of-progression onto the distal end once the plaster has set. Position the patient standing erect, with the pelvis "squared off" from the prosthetist's perspective. Mark the line-of-progression using an indelible pencil and straight edge.

Casting

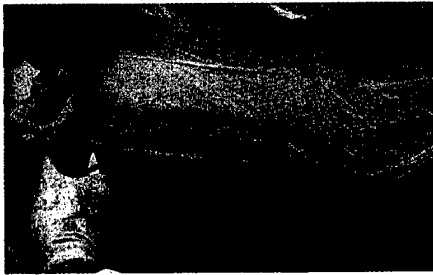

13. Remove the impression by cutting the garment and plaster wrap encircling the pelvis, over the sound side leg, with plaster scissors.

Casting



14. Evaluate the impression. The impression length should be at least as long as the measured limb length. Measure the length from the lowest point of the medial wall to the end along the central axis.

Conclusion

Add conclusion and transition here...



Ischial Containment Module Set

IV. Modifications of Positive Mold



Northwestern University Prosthetic Orthotic Center

This work was funded in part by the National Institute on Disability and Rehabilitation Research of the U. S. Department of Education under grant number H133E80031 and by the Department of Defense under award number DAMD17-00-1-0711

Statement of Purpose

This module is designed to teach principles involved in the fabrication of an ischial containment prosthesis.

It is part of a series of modules developed by the Center for International Rehabilitation with assistance from Northwestern University Prosthetic Orthotic Center and support of the National Institute on Disability and Rehabilitation Research of the U.S. Department of Education.

Introduction

The *purpose* of the modification process is to create a mold for the inside configuration of the socket. This is accomplished by removing and adding plaster in areas as required, and creating an overall shape and volume that is conducive to accommodating the firing muscles and that possesses the overall volume necessary to maintain suction suspension.

Prepare to Fill the Impression



Next mark a point on the medial shelf 1" medial to the adductor longus tendon. Then draw a line parallel to the Une-of-progression (LOP) through this point. Trim along this line with bandage scissors. Now close the medial aspect with two layers of plaster bandage. Use a piece of flat plastic to form the medial wall. The LOP should be parallel to the plastic

Module Objectives and Assignments

Add details here.

Prepare to Fill the Impression



Remove the garment from the impression. Outline the area where the ischial tuberosity should be located using the finger indentation and the measured A- P dimension as a guide. Also mark the adductor longus position.

Fill The Impression

Applying a parting agent, the cast will be placed in bench alignment prior to being filled. Therefore, the cast should be set in approximately 5 degrees of flexion or the measured flexion contracture plus 5 degrees.

This is to allow the amputee to take a sound side step *without excessive lordosis* in addition to placing the hip extensors on stretch, thus improving knee stability through out stance phase.

Fill The Impression

The cast should also be adducted. The normal mechanical axis of the lower limb is such that a line drawn through the femoral head will extend through the distal femur and down through the center of the ankle (Long's Line).

The femoral head is assumed to be at the bisection of the distance between the ischium and trochanter.

Fill The Impression

Fill the cast with plaster so the top of the plaster will be perfectly flat. Install a removable mandrel which extends vertically from the cast.

If a large amount of flexion is required, position the cast in a more vertical position with the mandrel representing the desired flexion. This will make vacuum forming easier (the cast will stand straight on the plate).

Cast Modifications

4. Identify ischial level and evaluate actual and desired limb length. In patients with redundant tissue, it would not be unusual to experience elongation of the impression and casting. Evaluate the discrepancy between the anatomical limb length and the length of the casting and divide the difference for a desired limb length.
5. Establish ischial level around the perimeter of the cast with indelible pencil. The model must be in the desired flexion and adduction positions when the ischial level is established.

Fill The Impression

This normal alignment is desirable in the case of the above knee amputee but not always attainable, especially in the case of a short, fleshy residual limb. Every effort should be made to achieve maximum adduction in order to enable the hip abductor mechanism to function in a normal fashion

Cast Modifications

1. Prior to stripping the cast, transfer the line of progression through the plaster bandage to the plaster model using awl.
2. Split plaster bandage from plaster model.
3. Re-establish indelible markings.

Cast Modifications

6. *Establish approximate trim lines:*
 - *Posterior:* 1" proximal to ischial level
 - *Lateral:* 3" proximal to ischial level
 - *Anterior:* 2" proximal to ischial level at the lateral 1/3 of the coronal diameter (M-L), then gradually descending to the anterior medial corner.
 - *Medial:* Continue the trim line from the posterior medial corner to the most distal aspect on the medial wall and connect to the anterior medial trim line.

Cast Modifications

6. Establish approximate trim lines:

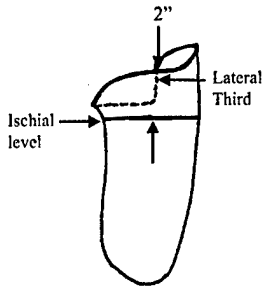

Anterior View

Anterior: 2" proximal to ischial level at the lateral 1/3 of the coronal diameter (M-L), then gradually descending to the anterior medial corner.

Cast Modifications

Establish approximate trim lines:

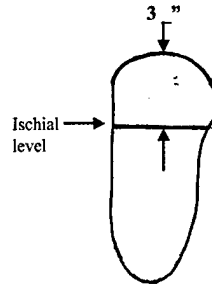

Lateral View

Lateral: 3" proximal to ischial level

Cast Modifications

Establish approximate trim lines:

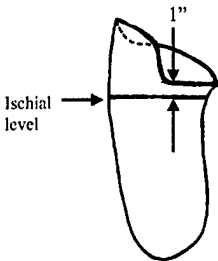

Posterior View

Posterior: 1" proximal to ischial level

Cast Modifications

Establish approximate trim lines:

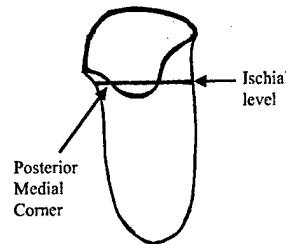

Medial View

Medial: Continue the trim line from the posterior medial corner to the most distal aspect on the medial wall and connect to the anterior medial trim line.

Cast Modifications

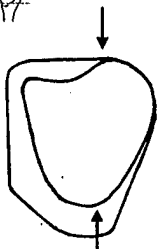
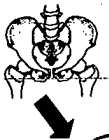

Cross Section at Ischial Level

7. Lateral A-P Dimension

- Take outside calipers and record the lateral A-P dimension of the unmodified plaster model. Measure this from the anterior aspect of the model to the posterior aspect of the model at ischial level.
- The plaster model will be significantly oversized in relation to your desired (recorded) lateral A-P dimension.

Cast Modifications

Cross Section at Ischial Level

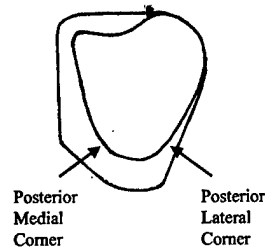

- In order to reach your goal for the lateral A-P dimension, remove plaster from the posterior aspect of the model. Concentrate your modifications at the ischial level and gradually *blend* to the posterior medial and posterior lateral dimensions.

Cast Modifications

Cross Section at Ischial Level

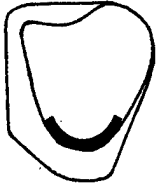

- When viewed in the transverse plane, this modification will look similar to a U-shape with the closed end of the U being the measured point of the lateral A-P (See Figure 1). The apex of the U is at the M-L bisector.

Cast Modifications

- Proximal to your established trim lines, flatten anterior surface parallel to posterior shelf (or perpendicular to medial shelf).

Cast Modifications

Tension Values		Residual Limb Musculature		
Level	Soft	Average	Firm	
Ischial	1"	1 1/8"	1"	
50mm	"	"	7/16"	
100mm	"	"	"	

Tension Values - The plaster model should still be oversized at this time. This will help you properly shape the plaster model for patient comfort. Proper surface bearing and biomechanically support as reach your reduction goals. Give care to the following areas of the plaster model to achieve these goals.

Cast Modifications

Cross Section at Ischial Level

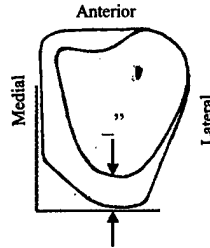

- 8. Orientation of the Brim** - Once your lateral A-P dimension has been achieved and you have worked to uniformly remove material from both the posterior medial and posterior lateral aspects, flatten the posterior shelf perpendicular to the medial shelf or line of progression (LOP). This shelf should be no more than 1/2" in width at the M-L mid-line.

Cast Modifications

Picture of pos. mold

- 9. Re-establish Circumferences**
- Transfer your circumference levels onto the posterior aspect of the plaster model beginning 1" distal to ischial level, then 2", 4", 6", etc.
- This manual describes the technique for fitting a total contact suction inter face. Base your exact, modification and reduction values on your initial patient evaluation. A quadrilateral reduction chart is provided for your reference.

Cast Modifications

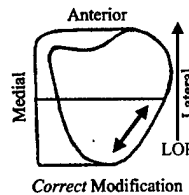

Correct Modification

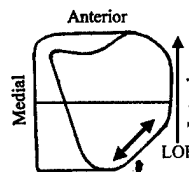

Incorrect Modification

10. Posterior Lateral Quadrant
This area is important for femoral stabilization in stance phase.

- Begin by modifying the posterior lateral aspect of the plaster model
- Flatten this area in approximately a 45 degree angle off the LOP.
- A common error made during this modification is neglecting to carry this flattening to the mid-sagittal line of the plaster model.

Cast Modifications

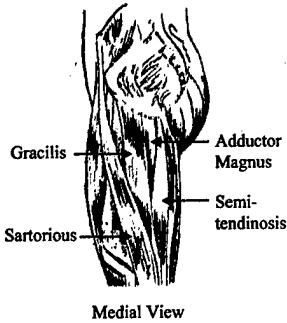

11. Posterior Medial Quadrant

- This area is important for ischial support and soft tissue stabilization.
- The posterior medial quadrant is composed a triangular area which is bounded by the semitendinosus posteriorly, the gracilis anteriorly, the inferior pubic ramus superiorly. The deep muscle of the adductor magnus occupies the floor of this triangle.

Cast Modifications

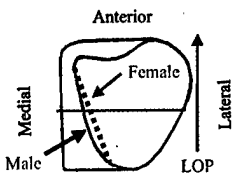

- When viewed from the transverse plane, this modification will have an internally rotated position relative to the LOP. The amount of internal rotation will vary depending on the anatomical structure of the patient.

Cast Modifications

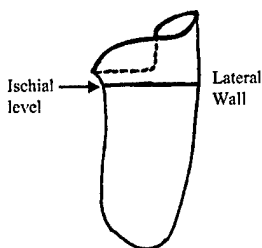

- ### 12. Anterior Surface -
- This area is important for allowance of muscular function in early swing phase, weight bearing in early stance phase, and rotational control throughout gait.

Cast Modifications

Picture of pos. mold

- Removal of plaster over this triangle compresses the soft adductor tissues. This provides excellent soft tissue stabilization, especially in early stance phase. The deepest point of this modification should be approximately 1 1/2 - 2" distal to the ischial tuberosity. A generous outward radius from the deepest point of this triangle to the ischial tuberosity is required and will be effected by the ischio pubic ramus angle.

Cast Modifications



As a general rule, the female patients will have a greater internal rotation angle than the male pelvis. Re-evaluate the circumferences

Cast Modifications

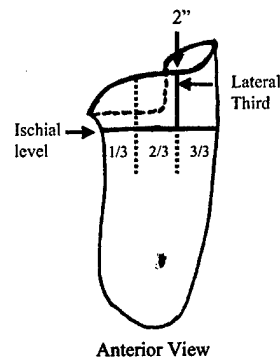

Delineation of Femoral (Scarpa's) triangle

- Begin by establishing the ischial level on the anterior surface with an indelible pencil.
- Divide the anterior aspect of the plaster model into thirds and delineate on the ischial line.
- Project the lateral third delineation proximally 2" to the established trim line.

Cast Modifications

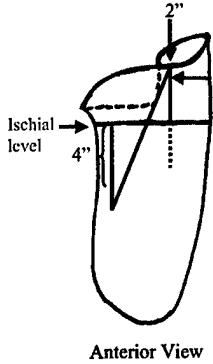

- From a point 1" lateral to the anterior medial corner and at ischial level, draw a line 4" distal and perpendicular to the ischial line.
- Connect the end points of the lines drawn in the previous two steps.
- From the lateral third proximal delineation draw a line with a gradual descent to the anterior medial corner.
- These lines indicate the boundaries of the femoral triangle and serve as a guide for shaping the area to a smooth contour.

Cast Modifications



13. *Establish the correct depth of the rectus channel* - Using a combination square, place the straight edge on the apex of the rectus femoris area and perpendicular to the medial wall. Measure the distance from the straight edge to the deepest point of the femoral triangle. This dimension should correspond closely to the values given in the following chart.

Cast Modifications

Position of Greater Trochanter	Depth of the Rectus Channel		
	Residual Limb Musculature		
	Soft	Average	Firm
Anterior	7/8"	1"	1 1/2"
Mid line	"	7/8"	1"
Posterior	5/8"	"	7/8"

This dimension should correspond closely to the values given in the following chart.

Cast Modifications

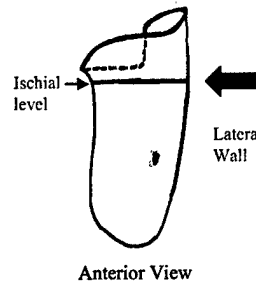

14. *Lateral Wall* - remove approximately 1/4" of plaster from the lateral aspect of the model at ischial level. This modification will assist in coronal stability that cannot be achieved during the impression.

- The remainder of the lateral wall from ischial level distal should be flat and follow the contours of the patient's femur.

Cast Modifications

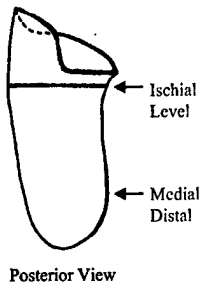

15. *Medial Distal* - Removal of plaster from the soft tissue of the medial distal aspect of the plaster model will result in total contact and improved adduction capabilities in the definitive interface. The amount of material removed will be greater with patients having redundant tissue and heavy subcutaneous tissue.

Cast Modifications

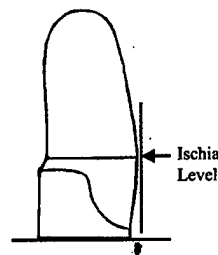

16. *Proximal Lateral* - Position plaster model in proper adduction attitude. Remove material proximal to ischial level.

- The correct amount of material to remove will be when the proximal lateral wall is at least vertical, when the plaster model is properly adducted. It may be cupped in 1/4".

Cast Modifications

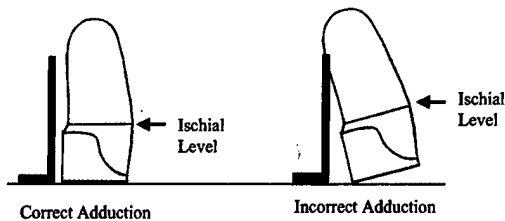

Determine the maximum amount of allowable adduction by placing a straight edge from the medial shelf and projecting to the medial distal surface of the cast. If the medial distal surface extends beyond the straight edge, then excessive adduction has been planned.

Cast Modifications

- Set the outside calipers to this measured medial A-P dimension.
- Position one leg of the caliper on the anterior medial aspect of the cast (adductor longus area) at ischial level.
- Mark the posterior medial aspect as indicated by the caliper. *This will represent the posterior edge of the ischium.*

Cast Modifications

- Variations in pelvic structure affect the amount of ischial containment. In the female patient with a small medial A-P dimension even 1" of ischial containment can be difficult to achieve due to the wide angle of the ischio-pubic ramus. A smaller amount of containment must then be used.
- A general range of 3/4 - 1 1/4" of ischial containment can be used and should have been evaluated during casting.

Cast Modifications

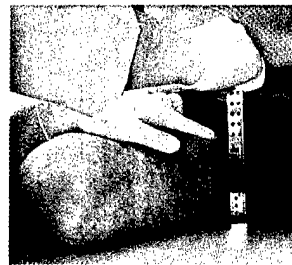

Anterior view of patient

17. Determining the Medial Trim line and the Amount of Ischial Containment. Take the medial A-P dimension from patient evaluation form. This measurement is the dimension from the posterior aspect of the ischial tuberosity to the anterior aspect of the adductor longus tendon.

Cast Modifications

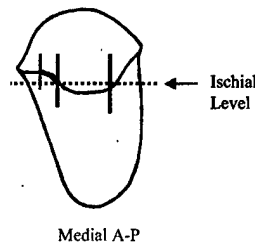

- Next mark a point approximately 1" anterior to the mark made in the previous step.
- To estimate the amount of ischial containment, transfer an approximate medial trim line from the posterior wall to the newly established 1" anterior mark*.

Cast Modifications

- Finish the modification by applying a generous radius of plaster to fill the area of the finger depressions. This also will allow room for the exit of the adductor tendons that attach to the ischial tuberosity and inferior ramus.