

# REPORT DOCUMENTATION PAGE

*Form Approved*  
OMB No. 0704-0188

Public reporting burden for this collection of information is estimated to average 1 hour per response, including the time for reviewing instructions, searching existing data sources, gathering and maintaining the data needed, and completing and reviewing this collection of information. Send comments regarding this burden estimate or any other aspect of this collection of information, including suggestions for reducing this burden to Department of Defense, Washington Headquarters Services, Directorate for Information Operations and Reports (0704-0188), 1215 Jefferson Davis Highway, Suite 1204, Arlington, VA 22202-4302. Respondents should be aware that notwithstanding any other provision of law, no person shall be subject to any penalty for failing to comply with a collection of information if it does not display a currently valid OMB control number.  
**PLEASE DO NOT RETURN YOUR FORM TO THE ABOVE ADDRESS.**

<b>1. REPORT DATE (DD-MM-YYYY)</b> 28-02-2003	<b>2. REPORT TYPE</b> Technical Paper	<b>3. DATES COVERED (From - To)</b> 01-10-2002 to 28-02-2003
--	--	---

<b>4. TITLE AND SUBTITLE</b>  Sealed, Blast-Resistant Windows for Retrofit Protection Against the Terrorist Threat	<b>5a. CONTRACT NUMBER</b> 8637-98-C-6001
	<b>5b. GRANT NUMBER</b>
	<b>5c. PROGRAM ELEMENT NUMBER</b> 6112

<b>6. AUTHOR(S)</b>  Dr. Mark Anderson, P.E. and Maj. Dov. Dover, P.E., I.A.F.	<b>5d. PROJECT NUMBER</b> 4397
	<b>5e. TASK NUMBER</b> D11E
	<b>5f. WORK UNIT NUMBER</b>

<b>7. PERFORMING ORGANIZATION NAME(S) AND ADDRESS(ES)</b> Applied Research Associates, Inc. Engineering and Science Division P.O. Box 40128, Tyndall AFB, FL 32403 Israeli Air Force (on assignment to AFRL/MLQD)	<b>8. PERFORMING ORGANIZATION REPORT NUMBER</b>
---	---

<b>9. SPONSORING / MONITORING AGENCY NAME(S) AND ADDRESS(ES)</b> Air Force Research Laboratory Airbase Technologies Division, Deployed Base Systems Branch 139 Barnes Drive, Suite 2, Tyndall AFB, FL 32403	<b>10. SPONSOR/MONITOR'S ACRONYM(S)</b> AFRL/MLQD
	<b>11. SPONSOR/MONITOR'S REPORT NUMBER(S)</b> AFRL-ML-TY-TP-2003-4525

**12. DISTRIBUTION / AVAILABILITY STATEMENT** (PA Case Number 03-018)  
Approved for public release, distribution unlimited. Paper is available in *Proceedings*, 2<sup>nd</sup> International Conference on Innovation in Architecture, Engineering and Construction (AEC), Loughborough University, UK, June 2003.

**13. SUPPLEMENTARY NOTES**

**14. ABSTRACT**  
Recent world events have drawn attention to threats that extend to the civilian population. A protective design approach for retrofit of existing structures has become increasingly palatable, despite the high costs, because of terror threats that were once considered "remote." Windows have always been one of the weakest points in most structures, primarily because of the requirement for transparency. Recent research at the Air Force Research Laboratory (AFRL) has addressed the difficult problem of retrofitting windows against the "combined threat" of a bomb blast followed by a chem-bio attack. In the recent Gulf War, several specific threats were highlighted for both US military forces and Israeli civilians. The most obvious threat to civilians in that conflict was explosive, as about forty SCUD missiles were launched into civilian areas of Israel. Less obvious, but even more potentially dangerous, was the threat of chem-bio weapons of mass destruction. Recognizing the weakness of entry points to chem-bio contamination, many Israeli civilians used plastic sheeting on the interior side of their windows during periods of increased threat. Recent research at AFRL has shown that, although cost-effective, this approach is woefully inadequate at the blast-pressures which would be expected in a terror attack, as clearly demonstrated by a sequence of still frames taken from blast test videotapes. The paper briefly discusses early pioneering work at AFRL that dealt with the use of clear polymer membranes (i.e., plastic sheets) to combat the combined threat, but the body of the paper focuses on recent developments in the evolution of "membrane" windows. The AFRL windows will resist blast high blast pressures, and will remain sealed against subsequent chem-bio attack, due to a patent-pending design which includes several key components: (1) polymer membranes, (2) a damping chamber, and (3) special anchoring techniques.

**15. SUBJECT TERMS**  
Windows, Membrane Action, Damping Chamber, Blast-Resistant, Protective Design, Retrofit

<b>16. SECURITY CLASSIFICATION OF:</b>			<b>17. LIMITATION OF ABSTRACT</b>	<b>18. NUMBER OF PAGES</b>	<b>19a. NAME OF RESPONSIBLE PERSON</b>
<b>a. REPORT</b>	<b>b. ABSTRACT</b>	<b>c. THIS PAGE</b>			Mark Anderson
U	U	U	UU	10	<b>19b. TELEPHONE NUMBER (include area code)</b> (850) 283-3730

## SEALED, BLAST-RESISTANT WINDOWS FOR RETROFIT PROTECTION AGAINST THE TERRORIST THREAT

**Mark Anderson, Ph.D.**

*Mark.Anderson@Tyndall.AF.Mil*  
United States Air Force Research Laboratory (AFRL/MLQD)  
139 Barnes Dr., Ste. 2, Tyndall Air Force Base, Florida 32403

**Maj. Dov Dover, IAF**

*Dover@gulf.net*  
on assignment to: United States Air Force Research Laboratory (AFRL/MLQD)  
139 Barnes Dr., Ste. 2, Tyndall Air Force Base, Florida 32403

20040130 135

### ABSTRACT

Recent world events have drawn attention to threats that extend beyond deployed forces, i.e., terror threats to the civilian population. A protective design approach for retrofit of existing structures has become increasingly palatable, despite the high costs, because of terror threats that were once considered "remote." Windows have always been one of the weakest points in most structures, primarily because of the requirement for transparency. Recent research at the Air Force Research Laboratory (AFRL) has addressed the difficult problem of retrofitting windows to provide inside space protection against the "combined threat" of a bomb blast followed by a chemical or biological (i.e., chem-bio) attack. In the recent Gulf War, several specific threats were highlighted for both US military forces and Israeli civilians. The most obvious threat to civilians in that conflict was explosive, as about forty SCUD missiles were launched into civilian areas of Israel. Less obvious, but even more potentially dangerous, was the threat of chem-bio weapons of mass destruction. Recognizing the weakness of entry points to chem-bio contamination, many Israeli civilians used plastic sheeting on the interior side of their windows during periods of increased threat. Recent research at AFRL has shown that, although cost-effective, this approach is woefully inadequate at the blast-pressures which would be expected in a terror attack, as clearly demonstrated by a sequence of still frames taken from blast test videotapes. The paper briefly discusses early pioneering work at AFRL that dealt with the use of clear polymer membranes (i.e., plastic sheets) to combat the combined threat, but the body of the paper focuses on recent developments in the evolution of "membrane" windows. The AFRL windows will resist blast pressures a full order of magnitude greater than typical "blast windows" on the commercial market, and will remain sealed against subsequent chem-bio attack, due to a patent-pending design which includes several key components: (1) polymer membranes, (2) a damping chamber, and (3) special anchoring techniques. And, with special mounting techniques, these windows can be scaled up to "store front" size, a key issue in many terror-threatened areas. Finally, and perhaps most importantly, while the windows may lose their transparency following a significant blast event, they are otherwise crystal-clear.

**Keywords:** Blast resistant, windows, retrofit, polymer membranes, damping chamber.

## HISTORICAL BACKGROUND

In the 1990s, concerns about a “combined threat” became a significant issue for the Air Force. The “combined threat” is the use of an explosive pressure wave to expose the inside of a structure to chemical or biological attack. In the past, research on blast-proof structures, including windows, had concentrated on eliminating such problems as shrapnel (i.e., explosive fragmentations), direct concussion, and indirect concussion effects (e.g., flying books or overturned furniture).

A first generation of combined threat windows went through several design iterations under threat conditions generally referred to as the “Warsaw-threat.” However, with the fall of the Berlin Wall and the breakup of the Soviet Union, there was a de-emphasis on research to support NATO-type structures. Recently, however, there has been renewed interest in the combined threat. For example, the use of aircraft as bombs by *al-Qaida*, followed soon after by the use of Anthrax by unknown terrorists (not to mention the possibility that West Nile virus was intentionally introduced) has implicitly increased the awareness of the combined threat in the civilian population of America. In addition, the international community, and Israel in particular, was made aware of the combined threat by the actions of Iraq in the Gulf War era. That is, during the Gulf War, Iraq used SCUD missiles in attacks on civilian targets (mainly in Israel); and soon after the Gulf War, Iraq used chemical weapons on its own dissidents. This willingness of a single country, or terrorist groups (known or unknown), to use both explosive and chem-bio agents has greatly increased the interest in developing retrofit techniques for resistance to the combined threat.

The new “terror threat” has led AFRL to develop a second generation of retrofit windows to resist the combined threat from terrorist organizations, rogue nations, and / or person or persons unknown. Using the research from the 1990s as a starting point, several dramatic improvements were implemented almost immediately. It is these second generation windows which are the main focus of this paper. The step-by-step developments which led to the final product(s) have been described elsewhere, and will not be repeated herein (see *Dover, Anderson, and Vickers 2002*). To avoid confusion about the different window forms and uses, a set of performance-oriented “nicknames” will be used herein (although all of these fall under the patent-pending collective term “Blast Proof Window Systems with Damping Chamber.<sup>PP</sup>”). These are: (1) the “Flex” window, shown in Figures 1 and 2a; (2) the “Super-Flex” window, shown in Figure 2b; and (3) the “Flex-Retrofit Flange system”, shown in Figure 3. (An unmounted Flex window is shown in Figure 4, both unfinished and finished with ESC.<sup>1</sup>)

## BASIC CONCEPTS

**Schematic.** Figure 1 is a schematic of the Flex window (same as Super-Flex except for film-anchoring system). The Flex / Super-Flex window system is composed of six major components: (1) double panels (glass and film laminate assemblies); (2) damping chamber; (3) rigid metal frame;

---

<sup>1</sup> See *Dover, Anderson, and Brown 2002*, for a complete discussion on the use of ESC, or elastomer sprayed coating (in that paper ESC is described for use in rapid runway repair).

(4) rigid window frame; (5) film anchoring system; and (6) air vents. When the blast wave impacts the front panel, the incident pressure bends the panel inward. The use of an elastic anchoring system, coupled with the elasticity/plasticity of judiciously placed films, allows the window to bow (i.e., act like a membrane). Additionally, the damping chamber traps air between the panels, so the air is both compressed and vented. The result is a system that reduces the pressure transferred to the back panel, and allows the two panels to oscillate at a controlled maximum amplitude, with exponential amplitude decay.

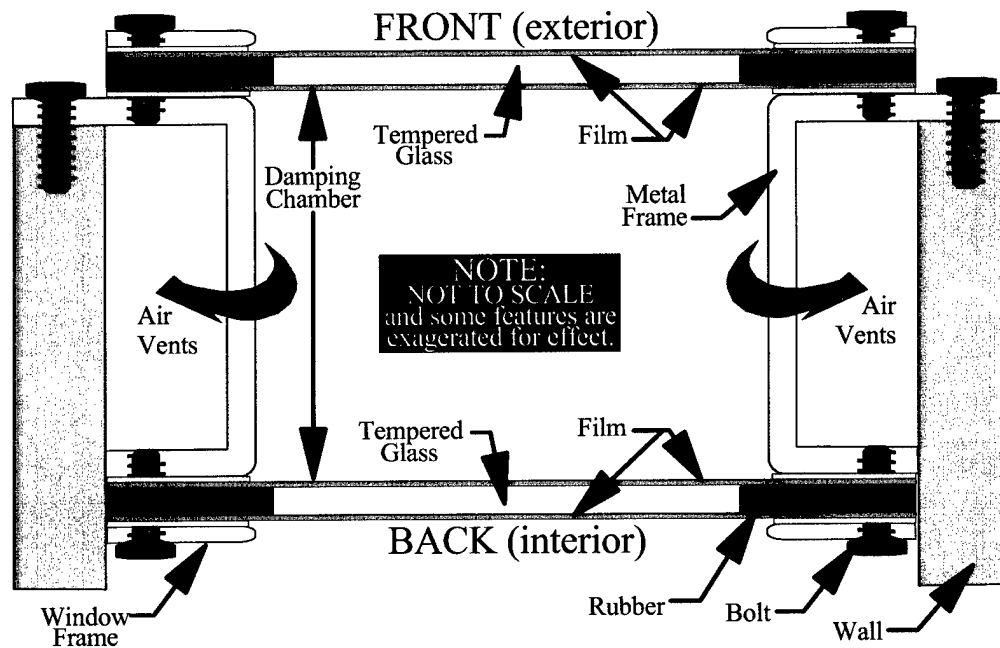

Figure 1. Schematic of "Flex" window, illustrating basic concepts.

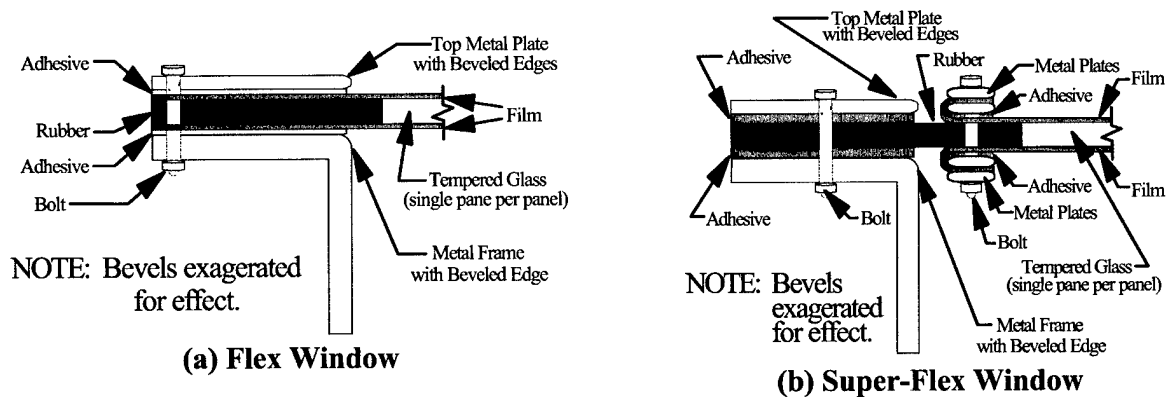

Figure 2. Film-Tail Anchoring Systems.

**The membrane concept.** Conceptually, the membrane concept replaces an otherwise rigid structural element with a structural element of similar structural capability, but which (either in lieu of, or in addition to) incorporates an elastic membrane, or the equivalent, to improve the resistance to blast pressures (i.e., high stress, transient loadings). The layman has an intuitive understanding of the membrane concept from observations of airplanes in flight. Wind loads on airplanes also

cause short duration, high stress loadings, which are resisted by the flexible metallic “skin” of the aircraft. The membrane concept is utilized in the Flex window to combat the “combined threat,” that is: (1) to provide elasticity to the panel for blast resistance; and (2) to keep a seal in the window opening to prevent subsequent chem-bio contamination. In addition, the membrane must allow visual access in its pre-blast configuration (several obvious solutions come to mind if visual access is not an issue).

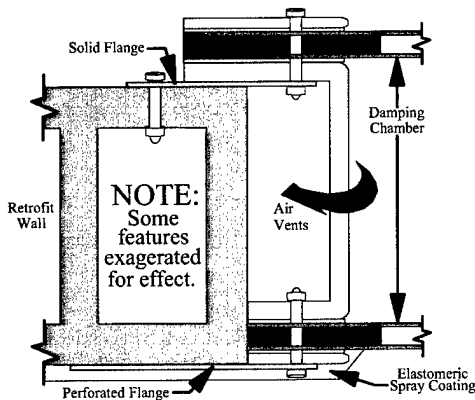
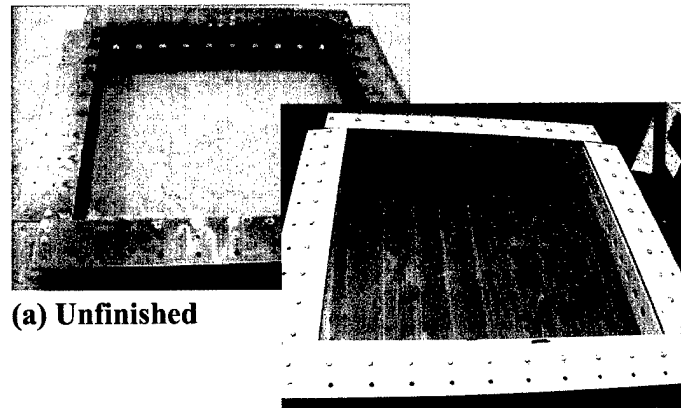

Figure 3. Flex-Retrofit Flange.



(a) Unfinished

(b) Finished

Figure 4. Flex Window (unmounted)

**The damping chamber concept.** The “damping chamber” is a vented air gap between the front and back panels of a “double panel” window that improves the blast resistance by “cushioning” the blast wave. The damping effect is sometimes easier to understand by considering the opposite, or unvented, case. If a double panel window is not vented, the front panel tends to deform inward under the incident pressure. As the front panel moves inward, the air trapped within the window tends to compress, thereby causing a transference of the pressure to the back panel. Conversely, when the air gap is properly vented, the chamber acts like a cushion, which can improve the performance of both the front and back panel. Obviously, pushing air out the vents reduces the internal pressure, which, in turn, reduces the pressure on the back panel. Perhaps less obvious, this “cushioning” also helps the front panel. This effect is similar to the damping of highway crash barrels used to protect automobiles in collisions with highway barriers (e.g., abutments), or the damping of an air bag used by stunt men to fall from great heights without serious injury. Figure 5 uses video frames to clearly demonstrate the importance of the damping chamber. Both windows in Figure 5 are Flex windows, but the one on the right has its back panel removed (no damping chamber). Blast-tested simultaneously, the Flex window with damping chamber (on the left) protects the building interior; while, conversely, the front panel of the Flex window without damping chamber (on the right) becomes a clearly dangerous interior projectile.

**The film tail anchoring concept.** Early versions of the AFRL blast-resistant windows (see *Dover, Anderson, and Vickers 2002*) experienced “pull-out” as the glass panel marbled and lost its ability to grip the polymer membrane (i.e., film). The pull-out produced results visually similar to the failed window in Figure 5 (although the mechanism in Figure 5 was different, i.e., shearing rather than pull-out). The introduction of “film tail anchoring” solved the pull-out problem with an extended edge, or “tail,” on the film to provide additional gripping between the frame and panel. By using a rubber anchoring system and a film tail, the Flex window does not depend on the relatively brittle

glass panels for the primary gripping force. The Flex window film-tail anchoring system is shown in Figure 2a. A more advanced film-tail anchoring system is used in the Super-Flex window, shown in Figure 2b. The Super-Flex system completely isolates the window from the rigid frame by an extended rubber edge piece. This allows the Super-Flex window to absorb even higher blast pressures, because the entire window moves as a unit until the elasticity of the edge rubber is exhausted – then, at that point, it still has the full blast-resistance of the standard Flex window.

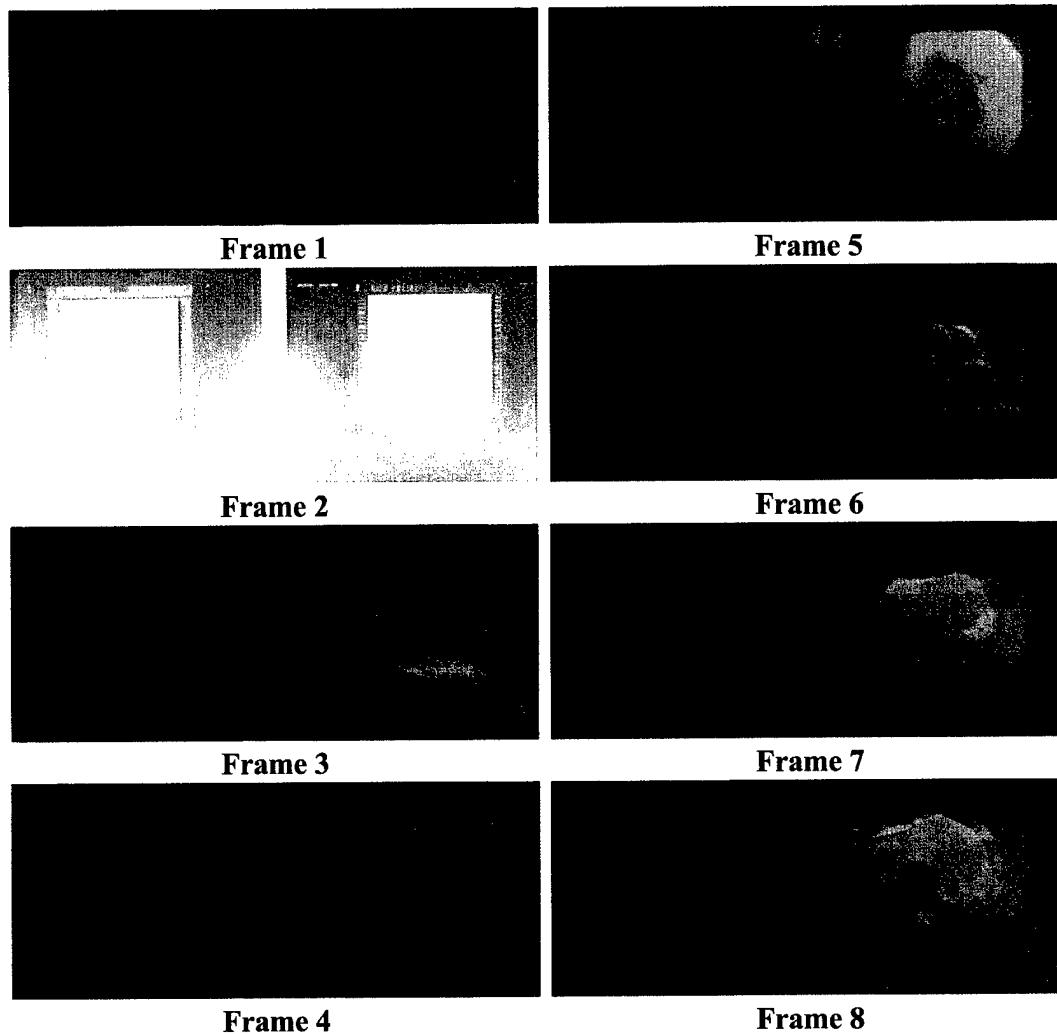

**Figure 5. Sequence comparing Flex window with damping chamber (on left) to Flex window without damping chamber (on right).**

**The Flex-Retrofit Flange system.** The Flex-Retrofit Flange system, shown in Figure 3, uses a slightly modified rigid window frame to fit a solid flange in front and a perforated flange in back. As shown in Figure 3, the solid flange is bolted to the exterior wall, while the perforated flange is bonded to the interior wall using ESC (the same ESC used to retrofit the wall for blast resistance<sup>2</sup>).

---

<sup>2</sup> A special retrofit method developed by AFRL, Tyndall Air Force Base, Florida.

By having perforations in the flanges, there is a mechanical connection (as well as an adhesion) between the wall, the polymer, and the window flange. The combination of a solid flange in front (connected with bolts) and a perforated flange in back (connected with sprayed polymer) makes the window and wall act as a unit. In particular, the key result is that the window and wall will oscillate at the same frequency (the entire window frame can break out if they are allowed to oscillate at different frequencies).

## BLAST TESTING – WINDOWS

**Blast Pressures.** Results shown in this paper were for nominal peak reflected pressure of 100 psi. A typical P-I curve<sup>3</sup> is shown in Figure 6 (this particular P-I curve is for the gauge inside the damping chamber of the Flex window for the initial blast test).

**Rigid Test Structures.** In order to gain the most information per explosion, a number of rigid test structures were built to hold the Flex windows. While the structures are relatively plane and are free-standing, the measured pressure on the back face is typically less than 10% of the pressure on the front face (see *Dover, Anderson, and Vickers 2002*). This result, while not completely negligible, is certainly indicative of a minor effect. The rigid test structures used for the Flex and Super-Flex windows are shown in Figure 7. AFRL is currently building a series of enclosed three-dimensional “buildings” for future blast-resistant window tests.

**Initial blast results.** The Flex and Super-Flex windows shown in Figure 7 had no glass weight loss after the initial blast (i.e., all of the glass was retained in the frame and film assembly). Views of the Flex and Super-Flex windows after the initial blast are shown in Figures 8 and 9.

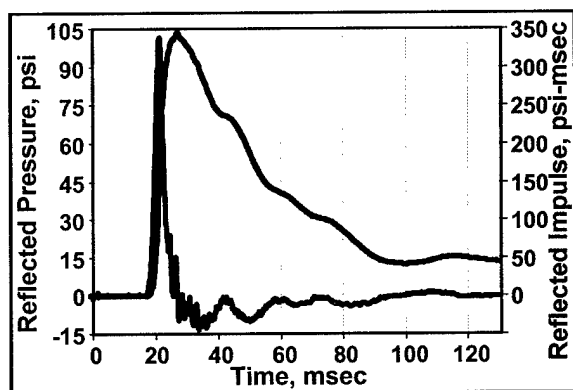

Figure 6. Typical P-I Curve<sup>3</sup> (inside gauge)

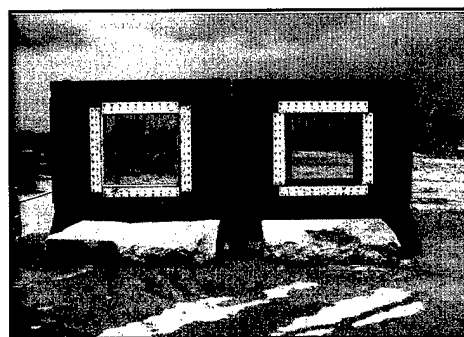
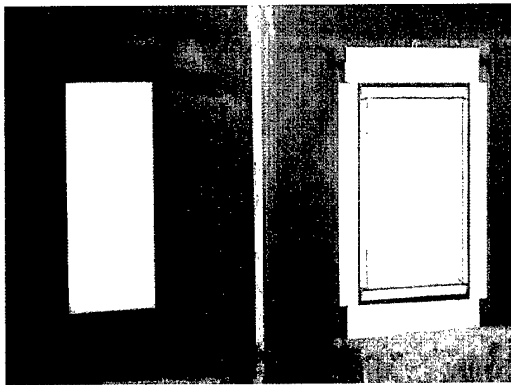

Figure 7. Flex and Super-Flex Windows in Rigid Test Structures (pre-blast)

**Leak Test of Post-Blast Flex window.** The Flex window had the higher measured blast pressure from the initial blast, and was chosen for a leak test. That is, after the blast test was completed, the window assembly was removed from the rigid test structure and tested for leakage in a simple, but effective, test. The window system was turned horizontally (back panel down), and flooded with water to a depth of 2 inches. The window system was observed for 3 days, and had no leakage whatsoever. The Flex window being tested for leakage is shown in Figure 10.

<sup>3</sup> P-I Curves are combined plots of Pressure-Time history and Impulse-Time history.



(a) Flex (b) Super-Flex  
Figure 8. Front – after initial blast.



(a) Super-Flex (b) Flex  
Figure 9. Back – after initial blast.

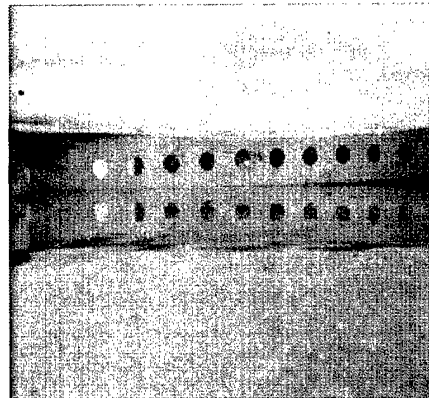
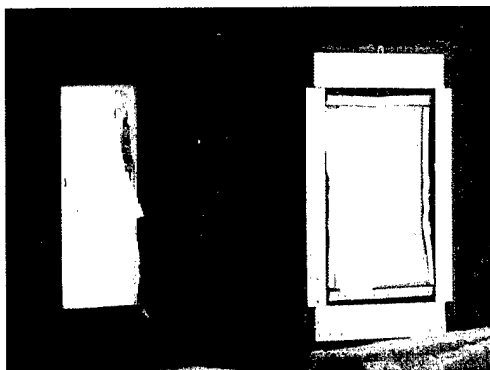
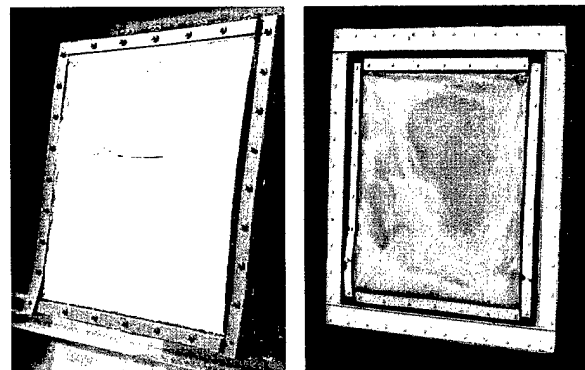

Figure 10. Post-Blast Leak Test

**“Blast after Blast” Test.** A common terrorist technique is to have two separate blasts, one to draw a crowd, and the second to maximize the damage. To test for this scenario, a “blast-after-blast” test was performed on the Flex and Super-Flex windows, as shown in Figures 11 and 12. The Flex window had significant tearing of the front membrane after the second blast, and minor tearing of the back membrane. Still, there was no ejecta from the back of the Flex window. The Super-Flex window had some tearing of the front membrane, but no tearing of the back membrane.



(a) Flex (b) Super-Flex  
Figure 11. Front – after 2<sup>nd</sup> blast.



(a) Flex (b) Super-Flex  
Figure 12. Back – after 2<sup>nd</sup> blast.

## BLAST TESTING – FLEX-RETROFIT FLANGE SYSTEM

**Flex-Retrofit Flange Design.** The Flex-Retrofit Flange allows either the Flex or Super-Flex window to be retrofitted in an existing wall. More specifically, the flange system helps make the window system an integral component of the existing wall. The test for the Flex-Retrofit Flange was intentionally severe, utilizing an existing CMU wall<sup>4</sup> (the concrete blocks have very little tensile strength, and there is minimal reinforcement in the CMU wall system). The Flex-Retrofit Flange method is designed to be installed concurrently with an interior wall retrofit using ESC to add interior wall blast protection. The geometry of the Flex Window is adapted slightly to allow the retrofit, as previously shown in Figure 3. The front metal plate (solid flange) is bolted to the front of the wall, as well as to the rigid window frame. The back metal plate (perforated flange) is bolted to the rigid window frame, and then attached to the back of the CMU wall by ESC during the interior wall blast protection retrofit. This attachment makes the window and wall, as much as possible, move simultaneously (as previously discussed).

**Blast Testing of Flex-Retrofit Flange.** The Flex-Retrofit Flange System was subjected to a blast with measured peak reflected pressure of 38-psi and measured reflected impulse of 183 psi-msec. This reduced blast pressure (compared to previous tests with nominal blast pressure of 100 psi) was necessary for the wall, not the window. Figures 13 and 14, respectively, show the pre-blast and post-blast condition of the front and back panels of the Flex-Retrofit Flange System. As expected, the window retained all of its pre-blast weight, and both panels stayed anchored to the frames. The instrumentation and videotape records show a high degree of inward deformation in the supporting structure (the CMU wall would almost certainly have fallen without the retrofit application of ESC inside the structure), yet the window was relatively unharmed. In addition, there was no apparent shearing of the exterior film, despite severe damage on the exterior surface of the CMU wall (see Figure 13(b) for the post-blast CMU wall damage).

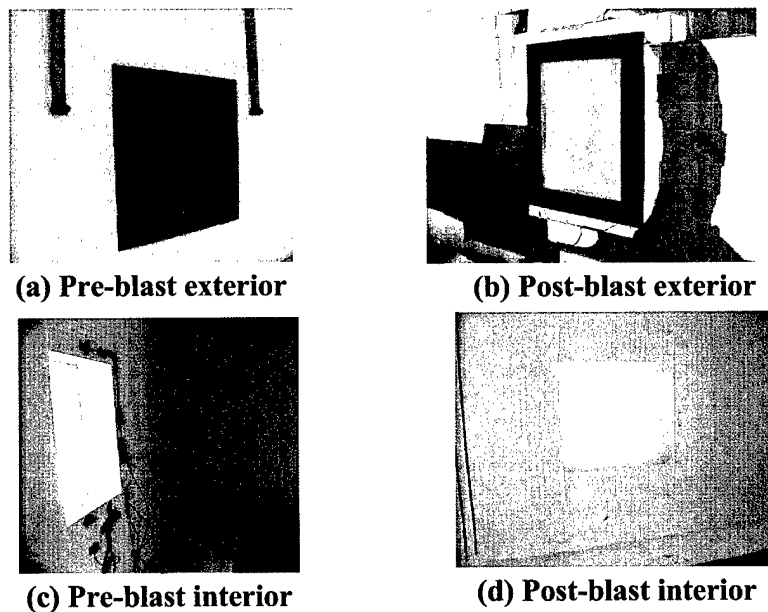

Figure 13. Blast test results for Flex-Retrofit Flange System

<sup>4</sup> CMU stands for concrete masonry unit, but the common term is “concrete block.”

**Flex-Retrofit Flange and other wall types.** Many types of walls which will be, or could be, retrofitted for blast protection have much better inherent blast protection properties than a CMU wall. Such walls should experience much less movement on blast impact, and will therefore work more like the rigid test structures used to test the Flex windows (as previously discussed). Based on testing a “worse-case scenario” (i.e., the CMU wall), and a “best-case scenario” (i.e., the rigid test structures), it seems that the Blast Proof Window Systems with Damping Chamber,<sup>PP</sup> outfitted with the perforated flanges and sprayed with ESC (when the wall is also sprayed with ESC), will perform adequately for any type of retrofit wall.

## **BLAST TESTING – FLEX WINDOW WITH ANNEALED GLASS**

The Flex and Super-Flex windows were designed to be made with tempered glass. The reason tempered glass was chosen was that under blast loading, the tempered glass marbleizes and is less likely to create jagged projectiles which would cut the interior membrane. However, the marbleized glass tends to drop down, and therefore lose its value as a stiffener / spacer in the window system (see, e.g., Figure 8 for a clear view of this phenomenon). Based on the blast-after-blast tests, annealed glass was tested as an alternative. The window system tested was otherwise identical to the previous Flex window tests, but each tempered glass pane was replaced with laminated-annealed glass (i.e., two thin panes of annealed glass with a “heat-welded” polymer sheet between). The laminated-annealed glass version of the Flex window worked very well, as shown in Figure 14. There was a marbleizing of the annealed glass, but the particles tended to stay in place, rather than drop down, due to the heat-sealing of the annealed glass to the inner polymer film. Based on the single blast test, it appears that laminated panels will work better for the blast-after-blast test, but this needs to be verified experimentally, and needs to be tried with both laminated-annealed glass and laminated-tempered glass.

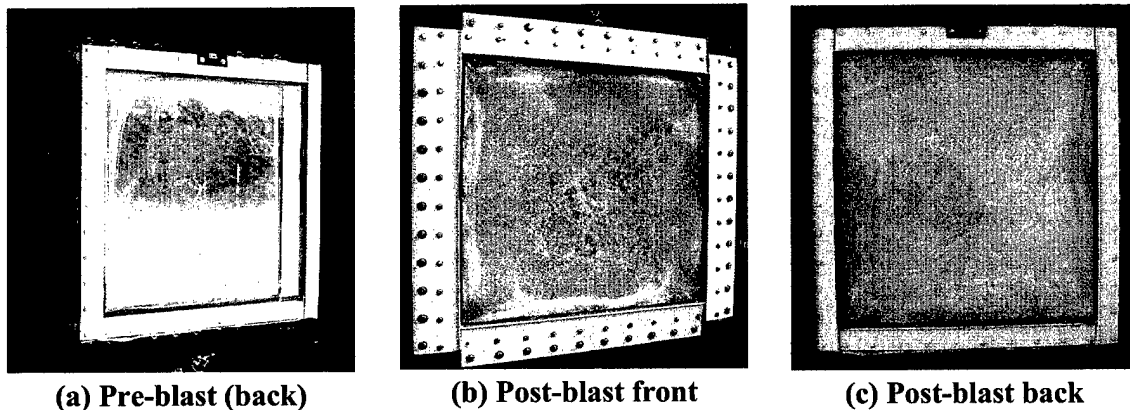

**Figure 14. Laminated-Annealed Glass Flex Window Test**

## **CONCLUSIONS**

### **Summary Conclusions**

Overall, the results of the tests on the Blast Proof Window Systems with Damping Chamber<sup>PP</sup> were judged a tremendous success, both in the Flex and Super-Flex configurations. Specific conclusions include:

1. The Super-Flex anchoring system adds substantially to the overall capacity of the

window system, by adding an elastic deformation in addition to the capacity of the Flex window system.

2. Observations verified that the both the Flex and Super-Flex windows will prevent glass shards from penetrating into a structure, even when subjected to a second blast (i.e., blast-after-blast test).
3. Both the Flex and Super-Flex window systems are adequate for chem-bio protection (i.e., the combined threat) after a single blast, as the interior clear polymer film was kept undamaged and remained tightly anchored in the frames. In addition, the Super-Flex window is adequate for chem-bio protection, even after a second blast, based on results of the blast-after-blast test.
4. The Flex-Retrofit Flange System makes the Flex window an integral part of an existing wall, even an unreinforced concrete block wall.
5. Laminated glass panes may be better than single panes for blast-after-blast, although more testing is needed, both for laminated-annealed glass and laminated-tempered glass.

### **Planned Future Research**

Several follow-on research and development studies are either currently underway, or will be underway soon. These include:

(1) A test series has been planned with the Blast Proof Window Systems with Damping Chamber<sup>PP</sup> mounted in a conventional structure using both laminated-annealed glass and laminated-tempered glass, and following with post-blast contamination testing using both liquid and gas intrusion tests.

(2) Computer modeling of the Blast Proof Window Systems with Damping Chamber<sup>PP</sup> is planned, which will allow parameter studies in the future, eventually reducing the number of blast tests required for verification of new system configurations.

(3) Additional research is planned which will lead to large size Blast Proof Window Systems with Damping Chamber.<sup>PP</sup> This research should allow store front size windows (on the order of 100 square feet, or more) which can resist an explosive attack followed by a chem-bio attack, with no degradation in protection compared to smaller windows.

### **REFERENCES**

Dover, D., Anderson, M., and Vickers, R.N. (2002) "Sealed Window Glazing System for Chemical Biological Protected Space Applications," *Proceedings*, NBC Defense Collective Protection Conference (COLPRO 02), Orlando, Florida.

Dover, D., Anderson, M., and Brown, R.W. (2002) "Recent Advances in Matting Technology for Military Runways," *Proceedings*, 27<sup>th</sup> Annual International Air Transport Conference, American Society of Civil Engineers, Orlando, Florida.