

REPORT DOCUMENTATION PAGE

Form Approved
OMB No. 0704-0188

Public reporting burden for this collection of information is estimated to average 1 hour per response, including the time for reviewing instructions, searching existing data sources, gathering and maintaining the data needed, and completing and reviewing this collection of information. Send comments regarding this burden estimate or any other aspect of this collection of information, including suggestions for reducing this burden to Department of Defense, Washington Headquarters Services, Directorate for Information Operations and Reports (0704-0188), 1215 Jefferson Davis Highway, Suite 1204, Arlington, VA 22202-4302. Respondents should be aware that notwithstanding any other provision of law, no person shall be subject to any penalty for failing to comply with a collection of information if it does not display a currently valid OMB control number. PLEASE DO NOT RETURN YOUR FORM TO THE ABOVE ADDRESS.

1. REPORT DATE (DD-MM-YYYY) 19-12-2003		2. REPORT TYPE Milestone 2 Final		3. DATES COVERED (From - To) 19-03-2003 to 31-11-2003	
4. TITLE AND SUBTITLE Enhancing Malaria Vaccine Development by the Naval Medical Research Center				5a. CONTRACT NUMBER N0014-02-C-0193	
				5b. GRANT NUMBER	
				5c. PROGRAM ELEMENT NUMBER	
6. AUTHOR(S) David D. Hile, Stephen A. Doherty, and Debra J. Trantolo				5d. PROJECT NUMBER	
				5e. TASK NUMBER	
				5f. WORK UNIT NUMBER	
7. PERFORMING ORGANIZATION NAME(S) AND ADDRESS(ES) Cambridge Scientific Inc. 180 Fawcett Street Cambridge, MA 02138				8. PERFORMING ORGANIZATION REPORT NUMBER USN4F2	
9. SPONSORING / MONITORING AGENCY NAME(S) AND ADDRESS(ES) Office of Naval Research 800 North Quincy Street Arlingngton, VA 22217-5660				10. SPONSOR/MONITOR'S ACRONYM(S) ONR	
				11. SPONSOR/MONITOR'S REPORT NUMBER(S)	
12. DISTRIBUTION / AVAILABILITY STATEMENT Approved for public release; distribution unlimited					
20040123 035					
13. SUPPLEMENTARY NOTES Milestone 2 report for Phase II. SBIR					
14. ABSTRACT DNA plasmid-based malaria vaccines have yielded a 100% immune response, but only 50% protection for 1-2 months. Biopolymeric excipients can provide initial delivery of the vaccine, as well as a controlled release that boosts the immune system to elicit a protective response. This Milestone 2 study evaluated delivery of a plasmid malaria vaccine using a proprietary biopolymeric vehicle. A VR2578 plasmid was able to elicit T cell responses when delivered in saline to mice; however, these results do not correlate to a protective response. The biopolymeric plasmid vaccine also elicited cell-mediated and humoral immune response. However, the number of biopolymeric responders was less than that of the soluble plasmid responders at the same time periods. In comparing these <i>in vivo</i> results with the <i>in vitro</i> studies of plasmid release from the biopolymeric excipient, the total dose released during the first 24 hours after each immunization was about 18% of the total contained within the excipient. Thus, mice received significantly less in the initial period when compared to the saline groups. The results suggest that the delivery rate and the time required to elicit an immune response affects vaccine performance. Given that a robust response can be achieved in follow-on studies by optimizing the dose in polymer, it remains the hypothesis that the controlled release element of the excipient can confer protection.					
15. SUBJECT TERMS malaria, vaccine, controlled release, DNA plasmids, biopolymer excipient					
16. SECURITY CLASSIFICATION OF:			17. LIMITATION OF ABSTRACT SAR	18. NUMBER OF PAGES 127	19a. NAME OF RESPONSIBLE PERSON Debra J. Trantolo
a. REPORT U	b. ABSTRACT U	c. THIS PAGE U			19b. TELEPHONE NUMBER (include area code) 617-576-2663

**Enhancing Malaria Vaccine Development by the
Naval Medical Research Center**

**Milestone 2
Final Progress Report: December 19, 2003**

**Contract No. N00014-02-C-0193
DOD Phase II SBIR**

Submitted to: Office of Naval Research

**TPOC: Capt. Daniel J. Carucci (301) 319-7570
Principal Investigator: Debra J. Trantolo, Ph.D. (617) 576-2663**

**Prepared by: David D. Hile, Ph.D., Stephen A. Doherty, Ph.D.,
and Debra J. Trantolo, Ph.D.**

**CAMBRIDGE SCIENTIFIC, INC.
180 Fawcett Street
Cambridge, MA 02138**

TABLE OF CONTENTS

Report Documentation Page	x
1. Executive Summary	3
2. Background and Significance	4
2.1. Malaria Vaccine Development	4
2.2. Delivery of Plasmid-Based Vaccines	6
3. Materials and Methods	8
3.1. Plasmid Vaccine Production	8
3.2. Impregnation of pDNA Vaccine	8
3.3. Characterization of Plasmid Release	10
3.4. Immunization in a Mice Model	10
3.5. Evaluation of Immune Response	11
4. Results	12
4.1. Microparticle Characterization	12
4.2. Characterization of Plasmid Release	13
4.3. Evaluation of Immune Response In vivo	14
5. Discussion	16
6. Conclusions	18
7. Objectives of Milestone 3	18
8. References	19
Appendices	23
Appendix A. NMRC Protocol for Mouse Immunization	24
Appendix B. NMRC Protocol for ELISA Assay	27
Appendix C. NMRC Protocol for LPA Assay	30
Appendix D. SRI Protocol for ELISPOT Assay	32
Appendix E. Tables	35
Appendix F. Figures	37
Appendix G. Equipment: Standard Operating Procedures	54
Appendix H. Materials: Standard Operating Procedures	75
Appendix I. Methods: Standard Operating Procedures	102

Phase II Progress Report

Milestone 2: Mouse Immunization with the Plasmid/Polymer System

1. Executive Summary

As stated in the DoD Solicitation (Topic Number OSD00-HP-02), "A major priority of the Department of Defense biomedical research is to develop effective vaccines for preventing *Plasmodium falciparum* and *P. vivax* malaria. As compared to developing vaccines against viruses and bacteria, developing malaria vaccines is complicated by the complexity of the parasite..and the complexity of the human host's response to the infection. Developing sustainably effective vaccines may require immunizing with an unprecedented number of parasite-derived proteins and/or the B and T cell epitopes from these proteins, using multiple vaccine delivery systems depending upon which arms of the immune system are to be activated. This topic requests development of efficient methods for producing immunogens.....and enhancing their immunogenicity."

Given the attention paid to the biology of malaria vaccines, current doctrine dictates that mode of administration may play a part in vaccine efficacy. As stated also in the Solicitation, administration of various protein-encoding genes et al. has shown that one can get, at best, 100% of an immune response, but only 50% protection for 1-2 months. Herewith, given this the background to the DoD Solicitation, is CSI's effort to respond to that solicitation, that response being directed to imparting both an immune response *and* protective efficacy.

It is of interest to explore the possibility of incorporating the biological part of a vaccine into a biopolymeric excipient. The use of a biopolymeric excipient may provide both delivery of the vaccine in the first days of treatment, as well as a controlled release of the vaccine that slowly primes the immune system to elicit a long lasting response, i.e., a response that is protective. In this SBIR, it has been proposed that Cambridge Scientific, Inc, (CSI) use its proprietary controlled release technology that speaks to benign matrix formulation principles to "gently" encapsulate biologicals and release those biologicals intact over a period of time.

The scope of the Milestone 2 SBIR study was to evaluate delivery of a plasmid malaria vaccine using CSI's proprietary biopolymeric vehicle. Mice were the recipient of the dose form; VR2578 was NMRC's plasmid of choice given its value as a model immune responder in the mouse model. This study biological has been shown in mice to elicit T cell and humoral immune responses. The immunization schedule and evaluative methods were based upon outcomes optimized for this plasmid when it is delivered in saline. Dose-dependent cell-mediated immune response was determined by measuring the number of antigen specific interferon-gamma (IFN- γ) secreting CD8+ T cells and humoral immune response antibody titers in mouse serum were determined using antibody resopinses,

A dose-response control study of immune responses validated that the VR2578 plasmid was able to elicit T cell responses when delivered at 50 μ g

(soluble plasmid) in saline, a plasmid and dose that has heretofore provoked an immune response, albeit not a protective one. The controlled release of a plasmid malaria vaccine incorporated in a PLGA biopolymer also elicited cell-mediated and humoral immune response in mice. Both cell-mediated and humoral immune responses were detected in mice receiving 50 µg of the test vaccine in biopolymer microparticles. However, the number of biopolymeric responders at the test periods was less than that of the soluble plasmid responders at those same time periods. In comparing these *in vivo* results with the *in vitro* studies of plasmid release from the biopolymeric excipient, the total dose released from the 50 µg during the first 24 hours after each immunization was about 18% of the total contained within the excipient. That is, at each immunization, mice received significantly less *in toto* over the first 24-hour period (approximately 9 µg). An additional 17% of the plasmid is released in the following two-week period and more slowly thereafter.

The results of this study suggest that the delivery rate of the plasmid and the time required to elicit an immune response affects vaccine performance. From the data on responders and on release rates, one can argue that a higher initial biopolymeric dose is needed to elicit a response. Given induction of a robust response, it remains the hypothesis that the controlled release element of the excipient can confer protection. Follow-on studies should be directed at the dose-response characteristics of the controlled release formulation and immunological analyses of responses at timepoints commensurate with release rates from the excipient. The results-to-date are encouraging and provide solid direction to the design of subsequent studies whether these studies be undertaken in mice or primates, the former of which represents a more simple system given that current primate studies involve the use of multiple plasmids and adjuvants.

2. Background and significance

2.1 Malaria Vaccine Development

Each year approximately 300 to 500 million people are infected with malaria and each year 1.5 to 2.7 million people die from this disease (Gardner et al., 1998; WHO, 1997). Since World War II, the struggle against malaria has gone through several stages. The first stage involved a massive effort aimed at eradicating the vector. The second stage was the development of antimalarial drugs based on quinine derivatives and alternatives (Shulemann, 1932; Corell et al., 1955). Due to introduced drug resistance, Miller and Hoffman (1998) stated that vaccination represents the best potential for control of the disease. The third stage of malaria control, then, recognizes the limitations of vector control and chemotherapy. In this regard, a current emphasis is on development of DNA-based vaccines against one or more of the developmental forms of the malaria parasite. Various strategies have been explored for implementing DNA-based vaccines.

Vaccines may prove beneficial to a wide range of populations. Proposed goals aim to prevent disease in foreign travelers and residents in low transmission areas such as India and reduce disease in high transmission areas

such as sub-Saharan Africa. Even vaccines demonstrated to provoke only low levels of antibodies might be useful in priming the immune system. Subsequent natural infection would help reduce the disease in high-risk populations such as children and pregnant women of Africa (Hoffman et al., 1998). The potential and applicability of malaria vaccines as a treatment method has led to the development of a number of candidates. Several additional candidate vaccines are expected in coming years upon sequencing of the *P. falciparum* genome (Gardner et al., 1998).

Vaccine trials have progressed from mice (Doolan et al., 1996) to monkeys (Wang et al., 1998) and into humans (Stoute et al., 1997; Wang et al., 1998). Malaria vaccines work by inducing the production of CD8+ T-cells that kill infected hepatocytes. Immunity stems from recognition of peptides present on the surface of infected hepatocytes by CD8+ T-cells that mediate infected cell elimination. Doolan et al., (1996) demonstrated partial protection ranging from 8 to 75 percent among various breeds of mice inoculated intramuscularly with DNA encoding for the *Plasmodium yoelii* circumsporozoite protein (PyCSP). Protection ranging from 80 to 90 percent was conferred onto mice by injection of a combination of plasmid vaccines namely PyCSP and *Plasmodium yoelii* hepatocyte erythrocyte protein 17 (PyHEP17). The success of the combination was attributed to a circumvention of genetic restrictions that lessened protective immunity mediated by CD8+ T-cells. Clinical vaccines are likely to include several protein-inducing plasmids to overcome genetic restrictions and handle parasite polymorphism.

Wang et al., (1998) applied the concept of multigene immunization in a study involving rhesus monkeys. Monkeys were injected three times at weeks 0, 4 and 16 at each of four intramuscular sites. The induction of antigen-specific antibodies required multiple immunizations. No antibodies were detected in any of the subjects following the first immunization. However, 8 of 12 monkeys demonstrated antibody production following the second immunization and 11 of 12 after the third immunization. Furthermore, 8 of 12 animals expressed CD8+ T-cell responses to all of the delivered epitopes and three additional animals showed CD8+ T-cell responses to all but one. These results help to support the effectiveness of the multiple epitope immunization approach.

Based on the encouraging results in nonhuman primates, Hoffman et al., (1997) proposed a plan to clinically test a multigene malaria vaccine in humans. Twenty malaria naïve volunteers were given three immunizations of the *P. falciparum* liver-stage DNA vaccine. The induction of CD8+ T-cell against the expressed protein was monitored by collection of peripheral blood mononuclear cells. Wang et al., (1998) reported that immune responses were detected in doses as small as μg , but doses ranging from 500 to 2500 μg elicited responses to approximately 70 percent of all of the peptides studied. In general, the magnitude of the immune response was also reported to be significantly higher than observed in humans exposed to conventional irradiated sporozoites or natural infection alone. Le et al., (2000) conducted safety studies and subjects observed mostly mild systems through one year following immunizations. However, the effectiveness of the vaccine was questioned, as there were no

detectable antigen-specific antibodies present despite an induction of CD8+ T-cell response. Stoute et al., (1997) conducted independent clinical trials of *P. falciparum* vaccines with mixed results. Human volunteers were vaccinated and then exposed to infection causing development of malaria in 100 percent of control subjects. Two vaccine formulations had little effect as the majority of volunteers contracted the disease, but a third formulation prevented malaria in seven of eight volunteers. Further studies were indicated to determine vaccine safety and reasons why the third formulation may have been more successful than others.

There have been measures to improve vaccine efficacy. Sedegah et al., (1998) demonstrated increases in protection by priming with the malaria vaccine and boosting with recombinant vaccinia. Malaria challenged mice demonstrated protection in 69 percent of the subjects boosted with vaccinia PyCSP, versus 44 percent of animals immunized with the DNA vaccine alone. Subsequent studies by Sedegah et al. (2000) combined both boosting with vaccinia PyCSP and coadministration of a plasmid expressing murine GM-CSF. Priming with PyCSP plasmid DNA and plasmid GM-CSF was demonstrated to confer protection to 100 percent of challenged mice dependent upon amount of recombinant vaccinia delivered during boosting.

2.2 Delivery of Plasmid-Based Vaccines

The use of homo- and copolymers of lactide and glycolide (PLGA) for biomedical applications is well-established and is based on the biocompatibility of these materials and their degradation products, lactic and glycolic acids (Visscher et al., 1985). Rates of degradation and release of incorporated active agents are dependent both on the molecular weight of the polymer and on the lactide-to-glycolide ratio. A sample list of proteins and peptides, which have been incorporated into PLGA has been compiled by Cleland and Langer (1994).

Traditional emulsion techniques for PLGA vaccines use blenders to generate the emulsions. However, the energy of this process results in some degradation of the DNA. As a consequence a large portion of the supercoiled material was degraded to the open circle or linear form. The damage is a consequence of the shear forces acting on the liquid components of the emulsion. The patented process proposed here does not involve emulsion formation and can be referred to as a "solid state" technique; this process should result in limited damage to the biological. Particle size reduction is accomplished by low temperature grinding (-40° to -50°C) of solid particles in which shear forces on liquid droplets do not occur. The impact on solid particles transfers energy to the particle that dissipates on fracture and results in only a transient temperature rise. Thus, denaturation, or other destructive processes are limited.

The effectiveness and longevity of pDNA vaccines may be improved by incorporation of pDNA within polymeric delivery vehicles. Administration of naked pDNA leaves the vaccine vulnerable to attack from degradation enzymes that can reduce half-lives to minutes or hours (Kawabata et al., 1995, Luo and Saltzman 2000). Chemical modification of DNA has previously been utilized to protect the vaccine from nucleases and increase vaccine longevity (Benns and Kim 2000, Luo and Saltzman 2000). Modified vaccines have been complexed

with cationic and anionic liposomes, polysaccharides, poly(ethylene glycol), and poly(L-lysine) among others. A drawback to chemical modification has been increases in systemic toxicity resulting from exposure to the complexed chemicals (Luo and Saltzman 2000).

A second alternative involves encapsulation of the plasmid within a polymeric carrier. Biodegradable PLGA systems provide protection for the plasmid, while enabling a sustained and controlled release of the plasmid. Anchordoquy and Koe (2000) reviewed the stability of plasmid-based therapies and suggested that polymeric carrier vehicles such as PLGA may have potential to isolate and entrap DNA. Isolation of the plasmid may prove to be beneficial in reducing negative interactions such as aggregation that leads to loss of biological activity in typical liquid formulations. The application of PLGA to biomedical applications is well established and is based on the biocompatibility of these materials and their degradation products, lactic and glycolic acids (Visscher et al., 1985). Control of plasmid release may improve vaccine efficacy because prolonged availability may enable sustained gene expression (Labhasetwar et al., 1998).

Plasmid-based therapeutics may be encapsulated within and released from polymer-based vehicles. Tinsley-Bown et al., (2000) demonstrated the release of a firefly luciferase-derived plasmid from microcapsules of a PLGA. *In vitro* studies found that the release rate of the plasmid into solution was dependent upon polymer molecular weight. Perez et al., (2001) encapsulated plasmid DNA into nanoparticles of poly(lactic acid) and poly(ethylene glycol) copolymers. In this study, plasmid loadings of 10-12 µg per mg of polymer resulted in a large initial burst of plasmid from the matrix followed by a slower release for 28 days.

Whereas polymeric carriers provide advantages over naked pDNA injections, loss of vaccine effectiveness in terms of physical mass loss and structural rearrangement of pDNA has been observed for encapsulation within polymeric delivery vehicles. Encapsulation efficiency of pDNA within PLGA matrices has varied with technique. Various procedures modified from the traditional double emulsion/solvent evaporation technique have yielded encapsulation efficiencies in the range of 20-50 percent (Tinsley-Brown et al., 2000) and 30-35 percent (Capan et al., 1999). However, Cohen et al., (2000) reported a higher efficiency, 70 percent, for encapsulation of pDNA within nanoparticles of PLGA. In addition to mass loss during the encapsulation procedure, rearrangements of pDNA structure have also been reported. A significant decrease in the percentage of supercoiled pDNA in favor of open circle pDNA has been reported. Tinsley-Brown (2000) reported that 30-40 percent of pDNA was recovered in the supercoiled form with losses being attributed to the open circle conformation. Capan et al., (1999) observed an increased loss of supercoiling, 16 percent, for uncomplexed pDNA. However, through forming of pDNA-poly(L-lysine) complexes, the percentage of pDNA remaining in the supercoiled structure increased to 75-85 percent.

The effectiveness of pDNA vaccines delivered in a PLGA vehicle has been demonstrated *in vivo*. Cohen et al., (2000) showed that a sustained release

of pDNA from PLGA microparticles increased expression of alkaline phosphatase versus an injection of naked pDNA beyond 7 days. However, injections of polymer-encapsulated pDNA resulted in less expression versus naked pDNA for a period of 72 hours post-injection. This observation was attributed to the reduced availability of encapsulated pDNA with respect to the naked pDNA solution or diminished effectiveness of the vaccine due to rearrangements of pDNA structure. Yet, the polymeric delivery vehicle enabled sustained release of pDNA vaccine. Lunsford et al., (2000) demonstrated persistence of pDNA within specific tissues in mice for a period of 120 days following intramuscular or subcutaneous injections. Tissues exposed to injections of naked pDNA were observed to be absent of pDNA beyond 15 days post-injection. Vaccine effectiveness may also be benefited by the potential of the polymeric particles to mediate transfection of macrophages during phagocytosis (Cohen et al., 2000).

3. Materials and Methods

Biopolymer microparticles containing impregnated plasmid were prepared and characterized under Good Laboratory Practices (GLP) established by Cambridge Scientific, Inc. Standard operating procedures were developed for operation of equipment used in the production process, characterization of materials and reagents, and methods used during the production process. The GLP protocols established during this Phase 2 project include preparation of microparticles with impregnated plasmid and quality control criteria regarding plasmid impregnation efficiency and *in vitro* release. The GLP protocols created for the production of plasmid malaria vaccines in PLGA microparticles may be found in Appendices G through I. GLP protocols may be transitioned to Good Manufacturing Practices (GMP) in Phase 3 with respect to scale-up and manufacturing in support of investigational new drug (IND) applications to the FDA.

3.1. Plasmid Vaccine Production

Preclinical grade plasmid was manufactured and characterized by Puresyn, Inc. (Malvern, PA, Lot No. C25OCT02A). The plasmid under investigation in this study, VR2578, was prepared from a sample procured from the Naval Medical Research Center. The plasmid was 93.9 percent supercoiled with the remainder having an open-circle structure. The size of the VR2578 plasmid was approximately 6000 bp, as measured by gel electrophoresis. Plasmid was stored in 0.9 percent saline at a concentration of 1.77 mg/mL and frozen (-20°C) prior to use.

3.2. Impregnation of pDNA Vaccine

PLGA microparticles were prepared for use as an adjuvant for the delivery of a plasmid malaria vaccine (VR2578) using a matrix impregnation technique. A porous biopolymer matrix was impregnated with the plasmid to distribute the vaccine. First, a solution of PLGA in glacial acetic acid (50 mg/mL) was quick-frozen for 10 min. in a dry ice/isopropanol bath. The frozen solution was freeze-dried (Labconco, Model 75040 Freeze Dryer 8, Kansas City, MO) for 48 hours to produce a porous matrix. The void volume of the matrix was approximately 94

percent as determined by foam density. An aqueous solution of VR2578 was loaded into the matrix under reduced pressure such that the percentage of plasmid to PLGA was 1 percent by weight. Finally, the vaccine-loaded foam was quick-frozen in a dry ice/isopropanol bath and freeze-dried for an additional 48 h.

Extrusion of the particles to form rods or cylinders impregnated the plasmid within the polymer matrix. The VR2578/PLGA foams were cryogenically ground (A10 Mill, IKA Works, Wilmington, NC) at -5°C to produce microparticles and then added to a 0.75-in. stainless steel mold. A load of 18,000 lb (corresponding to 40,000 psi) was applied to the mold and rods were extruded through a 1.3-mm die over the course of 1.5 h using an Enerpac press (Enerpac hydraulic press, Model RR-1006). The temperature of the mold was raised to 50°C in order to plasticize the polymer phase and increase the mobility of the polymer chains to enhance plasmid encapsulation.

Polymer microparticles containing the encapsulated plasmid were produced through a combined grinding/sieving apparatus. The extruded rod was ground on the mill to yield VR2578/PLGA microparticles. Ground particles were sieved through a 43- μm , stainless steel mesh (325 Mesh, Cambridge Wire Cloth, Cambridge, MD) to isolate the smallest-sized particle fractions. Particles were sieved during the grinding process under reduced pressure (Edwards Vacuum Pump, E2M-1, Crawley Sussex, England). In addition, control particles without plasmid were prepared using the same procedure. The yield of VR2578/PLGA collected beyond the sieve was approximately 50 percent of the total mass as measured prior to extrusion.

Microparticle particle size distribution was characterized using light and scanning electron microscopy. Representative samples of VR2578/PLGA particles were placed on a glass slide, viewed under a light microscope (Micromaster I, Westover Scientific, Mill Creek, WA), and photographed (Nikon CoolPix 990 Digital Camera). The size of particles ($n=850$) was measured from the digitized images using Scion Image for Windows, Release Beta 4.0.2. Particle size mean, median, and distribution were calculated for both particle numbers and mass.

The quantity of plasmid impregnated within the polymer particles was measured by extracting the plasmid from the polymer phase. A basic environment was used to catalyze polymer degradation and vortex mixing was used to release the plasmid from the polymer phase. Tinsley-Brown et al. (2000) described this technique for measuring the quantity of plasmid loaded into PLGA systems. Random microparticle samples with a mass of 10 mg were suspended in 1.5 mL of 0.2 M NaOH and incubated at 120°C for 10 min. The basic environment and elevated temperatures promoted degradation of the biopolymer system and release of the pDNA. Following the incubation step, the suspended particles were agitated on a vortex mixer for 1 min. The concentration of VR2578 in solution was measured using UV spectroscopy. For concentration measurement in NaOH, solutions of known pDNA concentrations were created in 0.2 M NaOH for the calibration curve. In addition, the reference background was a NaOH solution incubated with control PLGA particles that did not contain any plasmid. Samples sizes of $n=5$ were used to characterize the quantity of

impregnated pDNA in each microparticle batch produced. Batches of microparticles were accepted if the quantity of impregnated plasmid fell within five percent of the theoretical loading ($10.0 \pm 0.5 \mu\text{g}$ VR2578 / mg PLGA).

3.3. Characterization of Plasmid Release

The release of VR2578 from the PLGA carriers was characterized *in vitro* to assess plasmid encapsulation and expected delivery rate from the matrix. PLGA particles containing the encapsulated pDNA with an approximate mass of 10 mg were suspended in 1.5 mL of 0.1 M phosphate buffer saline (PBS). The suspension was incubated at 37°C and shaken at 60 cycles per minute in a PolyScience model 28L water bath. A total of six samples were added to the water bath and the quantity of released plasmid was measured at times of 1, 4, and 24 h and at 7, 21, 28, 35, 42, 49, and 56 days. Upon removal from the water bath, suspended particles were isolated by centrifugation at 50,000 rpm for 10 min. The supernatant solution containing released pDNA was collected with a pipette.

The concentration of pDNA in solution was measured by UV spectroscopy as described by Tinsley-Brown et al. (2000). Approximately 0.5 mL of pDNA solution was added to a quartz cuvette of path length 1 cm and width of 0.2 cm. Solutions of native VR2578 were diluted in PBS to known concentrations to serve as calibration standards. These solutions with known concentrations of pDNA were used to measure the unknown concentrations of pDNA by creating an absorbance versus concentration standard curve. Absorbance was recorded at 260 nm for each solution on a Varian Cary Scan 100 UV/Vis spectrophotometer. A reference absorbance background was provided by a PBS solution that was incubated with control PLGA particles not encapsulated with pDNA.

The quantity of plasmid remaining within the polymer particles was measured by accelerating the release of retained plasmid following 56 days of incubation. A basic environment to catalyze polymer degradation and vortex mixing to promote release of the plasmid from the polymer phase resulted in the remainder of encapsulated plasmid to be released. After 56 days of incubation, microparticles and the remaining encapsulated pDNA were isolated from the PBS supernatant. The microparticles were suspended in 1.5 mL of 0.2 M NaOH and incubated at 120°C for 10 min. The basic environment and elevated temperatures promoted degradation of the biopolymer system and release of the pDNA. Following the incubation step, the suspended particles were agitated on a vortex mixer for 1 min. The concentration of VR2578 in solution was measured using UV spectroscopy. For concentration measurement in NaOH, solutions of known pDNA concentrations were created in 0.2 M NaOH for the calibration curve. In addition, the reference background was a NaOH solution incubated with control PLGA particles that did not contain any plasmid.

3.4. Immunization in a Mouse Model

A preclinical study was conducted in a mouse model to evaluate immune response and effective doses associated with administration of CSI's vaccine/PLGA system. The study was performed under subcontract with

Southern Research Institute (Frederick, MD) under the direction of Mark G. Lewis, Ph.D., Manager Animal Models/Vaccine Research. The Milestone 2 animal research protocol was reviewed and approved by Rebecca A. Wiltshire, D.V.M. of the Navy Bureau of Medicine and Surgery.

Immunization techniques applied in this study were modified from standard operating procedures used at the Naval Medical Research Center (Appendix A). Briefly, female, BALB/c mice aged 4-5 weeks were immunized with the VR2578/PLGA system or VR2578 in saline as a positive control. One group was immunized with a suspension of PLGA particles without the plasmid vaccine as a negative control. Doses of the plasmid vaccine for each experimental group ranged from 0.5 to 50 μg (Table 1, Appendix E).

Vaccines were injected intramuscularly via the tibialis anterior muscle. Vaccines were administered in 100 μL of solution (saline or diluent) with 50 μL being injected into each tibialis anterior muscle. The saline vehicle was Dulbecco's phosphate buffered saline (Invitrogen Corp.) and the diluent consisted of sodium carboxymethylcellulose (3.75 mg/mL distilled H_2O), d-mannitol (37.5 mg/mL), and Tween 80 (0.75 mg/mL). PLGA microparticles were suspended in the diluent by vortex mixing for 5-10 s immediately prior to injection. Following the injection, each animal received an ear punch for identification purposes.

3.5. Evaluation of Immune Response

ELISA Assay: Serum levels of anti-Plasmodium yoelii sporozoite antibodies were measured using an ELISA assay. The ELISA protocol was established previously by NMRC and a copy of the protocol is attached (Appendix B). Serum samples (200-300 μL) were collected at 5 and 8 weeks through retro-orbital bleeding. Blood samples were screened for anti-Plasmodium yoelii-specific antibodies against a synthetic peptide sequence (4 \times QGPGAP, provided by the NMRC, Run #28798) of the PyCSP protein. Briefly, 96-well ELISA plates (Nalge/Nunc) were coated with synthetic peptide at the appropriate concentration and incubated overnight at 4 $^{\circ}\text{C}$. Non-specific protein-binding sites were blocked using 5% non-fat skimmed milk in PBS containing 0.05% Tween 20 and washed 6x in PBS containing 0.05% Tween 20 using an automated plate washer (Dynex). Serum samples were serially diluted in PBS/0.05% Tween 20; added at 50 μL /well and incubated for 1 hour at room temperature. Positive control serum NYS1 (50:24:5, provided by the NMRC) was included in the assay. After washing, specific anti-malaria IgG antibodies were detected using 1:10,000 dilution of affinity-purified goat anti-mouse IgG conjugated to horseradish peroxidase (HRP) as secondary antibodies (Southern Biotechnology, Inc., AL) followed by the addition of 100 μL /well 3,3',5,5'-tetramethylbenzidine (TMB) as substrate. After incubation for 5 minutes, color development was stopped with 50 μL of 2N HCL and absorbance read at 450nm using a kinetic ELISA plate reader (Molecular Devices, Menlo Park, CA). Samples were considered positive when the absorbance was greater than the mean absorbance value for the negative control (normal serum) plus 3 standard deviations. Results were expressed as log₁₀ endpoint titers.

Lymphocyte proliferation Assay: At Week 8, animals were sacrificed and spleen cells harvested. Cytotoxic T cell (CTL) activity was assayed using a lymphocyte proliferation assay (LPA). Proliferation was assayed by detecting ^3H -incorporation in splenocytes cultured with a peptide antigen (Appendix C). Freshly isolated splenocytes from immunized and control mice were prepared. Briefly, whole spleens were homogenized in RPMI 1640 growth media, red blood cells lysed, and washed twice by centrifugation at 1200 rpm for 5 minutes. Single-cell splenocytes were suspended in RPMI 1640 growth media containing 5% FBS, 0.5% gentamicin and 5.0 % glutamine as used in the assay. Cells were added in triplicate, at 2×10^5 cells/well to 96-well round-bottom microtiter plates in 200 mL RPMI 1640 growth medium. Splenocytes were stimulated for 4-5 days at 37°C in the presence of $10 \mu\text{g/ml}$ PyCSP peptide – KIYNRNIVRLLGD; amino acids 57-70 (provided by NMRC), PHA, or media alone. Splenocytes were then pulsed with 1 mCi/well ^3H -thymidine (NEN), incubated 18 h at 37°C and then harvested onto filtermats. ^3H -thymidine incorporated into cellular DNA was measured as counts per minute (c.p.m.) in a β -Counter (Wallac). Results were expressed as stimulation index (S.I.) = mean c.p.m. of stimulated splenocytes divided by mean c.p.m. of unstimulated splenocytes. Stimulation indices greater than 4 were considered positive.

IFN- γ ELISPOT Assay: In addition, an ELISPOT assay was performed on harvested spleen cells to detect antigen specific interferon-gamma (IFN- γ) secreting CD8+ T cells. The assay was performed using protocols established by the project subcontractor, SRI (Appendix D). Spleens were harvested from immunized and control mice at the time-points specified above and used for evaluation of malaria-specific cell-mediated immune responses. Briefly, whole spleens were homogenized in RPMI 1640 growth media, red blood cells lysed, and washed twice by centrifugation at 1200 rpm for 5 minutes. Single-cell splenocytes were suspended in RPMI 1640 growth media containing 5% FBS, 0.5% gentamicin and 5.0 % glutamine and used in the assay. IFN- γ -producing T-cells were measured using a commercially available kit (Cell Sciences Inc, MA). Briefly, 1×10^5 /well of freshly isolated splenocytes from immunized and control mice were added in triplicate to PVDF-bottomed 96-well microtiter plates pre-coated with an anti-mouse IFN- γ capture monoclonal antibody. Cells were stimulated with $10 \mu\text{g/ml}$ of either H-2d-restricted PyCSP peptide SYVPSAEQI; amino acids 280-288 - (provided by NMRC), Concanavalin A (ConA), or with medium alone and incubated for 18 h at 37°C . After washing, wells were incubated with biotinylated anti-IFN- γ detector antibody followed by streptavidin conjugated to alkaline phosphatase. Individual IFN- γ producing cells were visualized by the addition of BCIP/NTB as substrate. Purple spot-forming cells (SFC) were enumerated using an automated ELISPOT reader (Cell Technologies) and expressed as IFN- γ SFC/ 10^6 PBMC.

4. Results

4.1. Microparticle Characterization

The particle size of the biopolymeric microparticles loaded with the VR2578 plasmid was characterized using light and scanning electron

microscopy. Particles demonstrated a wide particle size distribution ranging from 1 to 45 μm (see Figure 1, Appendix F), but the median particle size was 8 μm based upon particle number and 22 μm by mass (see Table 2, Appendix E). The sieving technique effectively eliminated particles larger than 43 μm and 90 percent of the particles were less than 17 μm in diameter.

The quantity of plasmid impregnated within the PLGA microparticles was measured by extracting VR2578 from the polymer phase using 0.2 M NaOH. The procedure promoted the release of plasmid from the polymer phase into the aqueous environment. The concentration of VR2578 present in the supernatant was determined from the absorbance measured using a UV spectrophotometer at 260 nm. The impregnation technique reproducibly produced PLGA microparticles containing 10.0 ± 0.5 μg of plasmid per mg of polymer as established in the protocol acceptance criteria. For example, the quantity of VR2578 impregnated within PLGA microparticles used for the *in vivo* experiments had an average pDNA concentration of 10.26 ± 0.09 μg VR2578 per mg PLGA. The quantity of impregnated plasmid met the acceptance criteria for all four batches produced for the *in vitro* and *in vivo* studies.

4.2. Characterization of Plasmid Release

An *in vitro* procedure measured the impregnation efficiency and monitored the release profile of VR2578 from the biopolymeric microparticles. Release of the plasmid occurred at a controlled rate for 14 days from microparticles prepared by extrusion (see Figure 2). The plasmid was effectively impregnated using the extrusion technique and the burst effect was significantly reduced. Approximately 18 percent of the plasmid was released immediately upon immersion of the particles into buffer. The remainder of the plasmid was retained within the particles. An additional 17 percent of the total plasmid impregnated within the microparticle system was released through 7 weeks with most of the released VR2578 detected after 14 days. Although the quantity of plasmid released significantly decreased between 14 and 21 days, released VR2578 was detected in the buffer environment through 49 days.

The release of VR2578 from PLGA microparticles was modeled assuming Fickian diffusion of the plasmid to the buffer environment. For one-dimensional radial release from a sphere of a radius a , under perfect sink initial and boundary conditions, with a constant drug diffusion coefficient D , Fick's second law may be written as

$$\frac{\partial C}{\partial t} = D \left[\frac{\partial^2 C}{\partial r^2} + \frac{2}{r} \frac{\partial C}{\partial r} \right]$$

where

$$\begin{aligned} t=0 & \quad 0 < r < a \quad C=C_1 \\ t>0 & \quad r=a \quad C=C_0 \end{aligned}$$

The solution to Fick's law under the specified conditions is (Crank 1975; Ritger 1987):

$$\frac{M_t}{M_\infty} = 1 - \frac{6}{\pi^2} \sum_{n=1}^{\infty} \frac{1}{n^2} \exp \left[\frac{-Dn^2\pi^2t}{a^2} \right]$$

Using the empirical data collected in this study, the value of D calculates as 1.8×10^{-9} m²/s for early times. The theoretical release profile generally represented the empirical data (see Figure 2, Appendix F). However, the model did not account for the immediate release of plasmid (“burst effect”) from the microparticle system.

The percentage of intact plasmid retained in the polymer phase was measured at the end of the *in vitro* release study. At Day 56, the remaining polymer particles were collected and the plasmid remaining in the polymer phase was extracted. The extraction was performed by immersing the polymer in a basic environment (0.2 M NaOH) to catalyze polymer degradation and promote release of the VR2578. The concentration of released plasmid in the supernatant represented 31 percent of the total plasmid impregnated in the polymer. Therefore, a total of 66 percent of the initially impregnated plasmid was detected during either during the *in vitro* release study (35 percent) or following extraction from the polymer phase (31 percent).

4.3. Evaluation of Immune Response *In vivo*

The objective of this study was to evaluate a malaria vaccine against *P. yoelii* delivered in saline or via polymeric microparticles. Both embodiments of the vaccine were well tolerated and there were no adverse side effects. All animals survived the duration of the study. In order to investigate the humoral responses elicited by the vaccine approaches, serum samples were evaluated using ELISA techniques to measure anti- *P. yoelii* – specific antibodies. ELISPOT and LPA assays detected vaccine-induced CMI responses in splenocytes from immunized and mock-immunized mice.

The ELISPOT testing indicated that the VR2578 test vaccine induced a dose dependent immune response when administered in saline. Figure 3 shows that *P. yoelii* – specific CMI responses were induced in 2 of 8 (25%) mice immunized with 0.5 µg vaccine in saline (Group 1) with PyCSP peptide-specific responses of 80 (mouse 3) and 70 (mouse 6) IFN-g million spot-forming cells (SFC/10⁶) splenocytes. Splenocytes from all animals produced a strong response to ConA. Five of eight (62.5%) mice (3-7) immunized with 5.0 µg vaccine in saline (Group 2) demonstrated malaria-specific CMI responses ranging from 90-440 IFN-g SFC/10⁶ splenocytes. By contrast, 8 of 8 (100%) mice immunized with 50.0 µg vaccine in saline (Group 3) showed vaccine-specific CMI responses ranging from 130-1070 IFN-g SFC/10⁶ splenocytes. As expected mock-immunized mice (Group 7) failed to demonstrate PyCSP peptide-specific response. In the majority of cases, splenocytes from immunized and mock-immunized mice produced robust responses after *in vitro* stimulation with ConA, thus demonstrating the functional capacity of their T-cells to respond to *in vitro* stimuli.

Statistical analysis of the data revealed significant differences in the CMI responses induced by 5 and 50 µg vaccine (p values = 0.04 and 0.007 respectively) compared with the lower dose of 0.5 µg (Figure 4). These results clearly demonstrate a dose-dependent response, i.e. CMI responses increase as vaccine dose increases.

Although vaccine administered in PLGA microparticles within a CMC diluent demonstrated immune response in some animals, increasing the dose did not stimulate CTL response in all animals for the route of administration and doses under investigation. Figure 5 shows that *P. yoelii* – specific CMI responses were induced in 2 of 8 (25%) mice immunized with 0.5 µg vaccine delivered via polymeric microparticles (Group 4) with PyCSP peptide-specific responses of 70 (mouse 6) and 50 (mouse 8) IFN-g SFC/10⁶ splenocytes. With the exception of splenocytes from mouse 6, all animals produced a strong response to ConA. Mice immunized with 5.0 µg vaccine delivered via polymeric microparticles (Group 5) failed to demonstrate malaria-specific CMI responses. However, 4 of 8 (50%) mice immunized with 50.0 µg vaccine with saline (Group 6) showed vaccine-specific CMI responses ranging from 50-190 IFN-g SFC/10⁶ splenocytes. As shown earlier mock-immunized mice receiving only the PLGA vehicle (Group 7) did not demonstrate PyCSP peptide-specific response.

In contrast to the dose-dependent response observed in mice immunized with vaccine in saline, a relationship between vaccine dose and CMI response was not demonstrated ($p > 0.05$) in mice immunized with vaccine in polymeric microparticles (Figure 6). Thus, the *P. yoelii*-based malaria vaccine delivered via polymeric microparticles, in this study, did not induce a robust CMI response. The mean IFN-g SFC/10⁶ splenocytes obtained for Groups 1, 2 and 3 were directly compared with those of Groups 4, 5 and 6. No significant difference ($p = 0.92$) was demonstrated at the lower vaccine dose of 0.5 µg. By contrast, CMI responses induced by 5.0 and 50.0 µg vaccine delivered in saline were significantly higher (p values of 0.025 and 0.016 respectively) than those elicited by the same plasmid delivered via polymeric microparticles.

CMI responses were also measured by LPA assays on the same splenocyte suspensions, but using a different PyCSP peptide, KIYNRNIVRLLGD (amino acids 57-70). Splenocytes from all 56 mice, proliferated well in response *in vitro* to mitogenic stimulation with PHA. However, there were no significant increases in PyCSP-specific responses in any of the immunized mice (Figure 7; Groups 1-3 and Figure 8; Groups 4-6) above those seen in unstimulated splenocytes. Furthermore, these responses were not markedly different from those observed in the mock-immunized mice (Figures 7 and 8; Group 7). Thus, the LPA assay failed to demonstrate any *P. yoelii* – specific proliferative responses in this study.

Antibody response was not detected in serum samples collected at 6 and 8 weeks following the first immunization regardless of vaccine dose or delivery vehicle (saline versus PLGA particles). The results in Figures 9-12 represent *P. yoelii*-specific antibodies measured at Week 6 in mice immunized with 0.5, 5.0 or 50.0 µg of the test vaccine delivered either in saline (Figures 7 and 8; Groups 1, 2 and 3) or via polymeric microparticles (Figures 9 and 10; Groups 4, 5 and 6). Reactivity of anti-malaria-specific NYS1 positive control antibody against the QGPGAP peptide is shown on each graph, demonstrating the validity of the assay. However, serum samples obtained at week 6 from all groups of immunized mice failed to demonstrate a positive response. At week 8 post-immunization, only 1 (mouse #18) of 8 animals, given 50.0 µg of the malaria

vaccine delivered in saline (group 3), showed a positive response (Figures 13-16). Thus, the ELISA testing did not demonstrate significant humoral immune responses.

Anti-malaria-specific antibody response was detected using an immunofluorescence antibody test (IFAT), and the results were comparable to the ELISPOT assay. The IFAT study was conducted by NMRC staff with serum samples provided by Cambridge Scientific, Inc. Serum samples collected at 8 weeks were screened for humoral immune response against a positive control NYS1 mouse antibody. Serum samples from each experimental group were pooled in order to determine antibody response from the entire group. As with the ELISPOT results, the antibody levels for mice receiving the vaccine in saline increased with increasing plasmid dose. Antibody titers ranged from negative or no response for the 0.5 μg dose group, to 40 for the 5 μg group, and 640 for the 50 μg group (Table 3). The antibody titer for the 50 μg dose in saline represented 25 percent of the response from the positive control. For pDNA delivered in PLGA microparticles, there was no response detected at doses of 0.5 μg and 5 μg . However, there was a positive response in the 50 μg dose in PLGA with a titer of 20 (Table 3). Again, the results from the IFAT study are comparable to those found using the ELISPOT assay. Because the serum samples were pooled, the number of positive responders within each experimental group could not be determined. For example, the ELISA results suggested a significant antibody response in 1 individual mouse for the 50 μg dose delivered in saline, which corresponds to the experimental group with the highest antibody titer. Antibody titers were also measured from serum collected at Week 6 for both 50 μg dose groups. The response at Week 6 was similar to the response at Week 8 for both the saline and PLGA delivery vehicles.

5. Discussion

Plasmid malaria vaccines delivered via PLGA microparticles did not produce a robust immune response within the scope of this first mouse study. However, reconciliation of the delivery dose with the rate plasmid released from the PLGA system has not been optimized. Milestone 1 efforts developed an injectable PLGA vaccine system that was used to encapsulate a single plasmid (VR2578) and could be delivered to a mouse model via IM injection with a 27-gauge needle. The aims of Milestone 2 studies were to test this proprietary pDNA/PLGA system by administering the vaccine at doses ranging from 0.5 to 50 μg and comparing cell-mediated and humoral immune responses to the same plasmid delivered in saline. Vaccine doses and schedule of the study with respect to immunizations, serum collection, and endpoints were selected based upon conditions optimized in a mouse model for plasmid vaccines delivered in saline. The vaccine delivered in saline generated the anticipated dose-dependent cell-mediated immune response, but there were no significant levels of antibodies detected via ELISA. Significant immune responses were not observed in the PLGA system at doses of 0.5 and 5 μg . In the 50 μg in PLGA dose group, however, 4/8 mice exhibited immune responses in excess of the negative controls. Immune responses, as measured by ELISPOT assays, were

comparable between the 50 μg vaccine delivered in PLGA and the 5 μg dose delivered in saline.

Impregnation of the plasmid in PLGA microparticles enables sustained release, which has been measured through 49 days *in vitro*. Release of the plasmid from the PLGA microparticles may be characterized as three distinct phases: initial or "burst" release, steady release, and decreasing release. The initial or "burst" period spans from Time 0 when the system is administered through Day 1. Approximately 18 percent of the impregnated plasmid is released during this phase and represents antigen available near the surface of the microparticles. The steady release period lasts between Day 1 to Day 14, during which the rate of plasmid released is constant. An additional 17 percent of plasmid is released during this period. The decreasing release phase follows Day 14, where the quantity of plasmid detected significantly decreases with respect to time. The quantity of plasmid released during this period varies between 2-5 percent of the impregnated plasmid. At the end of the *in vitro* study, plasmid remaining in the polymer phase was extracted and measured at 31 percent of the initial loading. The remaining plasmid may ultimately be released from the polymer phase as the degradation and polymer erosion processes continue. The plasmid not detected in the polymer particles may be retained either by adsorption to the polymer surface or agglomeration of the plasmid. In addition, higher levels of plasmid may have been released from the particles, but degraded *in vitro* due to incubation at 37°C. The quantity of undetected plasmid (30-35 percent) is typical for PLGA controlled delivery systems (Tinsley-Brown et al. 2000; Cohen et al. 2000).

The immunization schedule and corresponding delivery rate of the malaria plasmid vaccine used in this study was optimized for bolus administration of the vaccine in saline. The sustained delivery system provides a prolonged release of the plasmid, but the initial quantity of plasmid present is substantially reduced. Figure 17 represents the quantity of plasmid delivered via administration in saline versus released from PLGA particles for a vaccine dose of 50 μg . The total dose of vaccine delivered from the PLGA particles with respect to time is represented by the area under the curve. Plasmid delivered in saline is immediately available to antigen presenting cells. Delivery of the vaccine in PLGA particles significantly reduces the quantity of plasmid immediately available to cells (approximately 10 μg during the first day). The dose reported for the PLGA system consisted of the total quantity of plasmid in the PLGA microparticles. Analysis of plasmid released *in vitro* indicated that 35 percent of the impregnated plasmid (corresponding to 17.5 μg) was released within 3 weeks. The dose of available plasmid affects the level of cell-mediated immune response as observed when the delivery vehicle is saline. It is not clear from this study whether the immediate availability or rate of vaccine delivery of vaccine affects priming of the immune system. When plasmid was impregnated in PLGA, comparable quantities of vaccine were delivered over a period of three weeks rather than immediately available.

The time required to measure maximum immune responses for vaccines delivered via PLGA microparticles does not always correspond with vaccines delivered in saline. Singh et al. (2001) investigated delivery of an influenza

vaccine at 0 and 4 weeks from polymer microparticles or in saline. Serum antibody responses increased approximately 50 percent in animals receiving the vaccine in particles as opposed to vaccine delivered in saline where the antibody levels remained unchanged. Lunsford et al. (2000) used different evaluation periods to determine immune response from naked DNA versus encapsulated DNA vaccine systems. The number of positive mouse responders was 6/6, 3/6, and 0/6 at Day 1, 15, and 70 respectively for naked DNA administration. However, the positive responders were 5/6, 6/6, 3/6, and 0/6 at Day 1, 30, 60, and 80 for DNA encapsulated in PLGA particles. The scope of the Milestone 2 study did not investigate the delivery rate of the vaccine and the temporal immune response invoked as a result of sustained delivery, rather the study compared naked pDNA and impregnated pDNA administration using methods and schedules optimized for the naked pDNA system.

The objective of the first mouse study was to test the delivery of a plasmid malaria vaccine using a controlled release particulate PLGA-based system. Although the focus of the current study was in a mouse model, these studies do not always correlate with vaccine efficacy in humans. As noted by Singh et al. (2001), "the limitations of small animal models and their inability to accurately predict responses in human subjects is well known and widely acknowledged." The Milestone 2 study demonstrated impregnation and delivery of a pDNA vaccine from PLGA microparticles, but the study outcomes were tested using criteria optimized for naked pDNA delivery in mice. Development of a controlled release vaccine will ultimately need to be tested in larger animals (e.g. rabbits or primates) to drive the technology towards human applications.

6. Conclusions

Controlled release of a plasmid malaria vaccine from biopolymeric, PLGA microparticles elicited an immune response in mice, but the level of the response was not optimized. A dose response study comparing delivery of the plasmid in saline versus PLGA particles indicated that the saline-based delivery provoked an increased immune response within the scope of the Milestone 2 study. Further development of the PLGA-based delivery vehicle for a plasmid malaria vaccine is required to investigate the affects of plasmid delivery rate, dose, mode of administration, and timeframe of immune response. The follow-on studies have implications not only to the development of a malaria vaccine that enables a robust and sustained immune response, but also to the broad field of controlled DNA delivery.

7. Objectives for Milestone 3

Further development of a controlled release malaria vaccine using a biopolymeric vehicle is proposed to optimize immune response. In order to best exploit the results of the mouse study to successful outcomes, it is proposed that the study design for follow-on efforts focus on:

- An expanded *dose response characterization in mice* with increasing the dose of plasmid in PLGA

- A combination of *naked DNA* for “priming” of the mouse immune system in conjunction with the *PLGA controlled release particulate* to “boost” the immune system
- Comparison of the *route of administration*: IM vs. ID

While the Milestone 2 results certainly speak to how best to optimize a plasmid system in mice, the understandings are directly transferable to larger animal malaria models acknowledging, however, the greater complexities of these. In addition, given the emergence of plasmid approaches to vaccines, successful outcomes with this effort will provide vital input to plasmid delivery that should be of benefit to other vaccines.

8. References

- MT Aguado and PH Lambert. “Controlled release vaccines-biodegradable polylactide/ polyglycolide (PLPG) microspheres as antigen vehicles,” *Immunobiology*, **184**:113–125, 1992.
- TJ Anchordoquy and GS Koe. “Physical stability of nonviral plasmid-based therapeutics,” *Journal of Pharmaceutical Sciences*, **89**:(3), 289–296, 2000.
- JM Bennis and SW Kim. “Tailoring new gene delivery designs for specific targets,” *Journal of Drug Targeting*, **8**:(1), 1–12, 2000.
- Y Capan, BH Woo, S Gebrekidan, S Ahmed and PP DeLuca. “Preparation and characterization of poly (D,L-lactide-co-glycolide) microspheres for controlled release of poly(L-lysine) complexed plasmid DNA,” *Pharmaceutical Research*, **16**:(4) 509–513, 1999.
- JL Cleland and R Langer. “Formulation and delivery of proteins and peptides: Design and development strategies,” Chapter 1 in ***Formulation and Delivery of Proteins and Peptides***, ed: JL Cleland and R Langer, *ACS Symposium Series 567*, American Chemical Society, Washington, DC, 1–19, 1994.
- H Cohen, RJ Levy, J Gao, I Fishbein, V Kousaev, S Sosnowski, S Slomkowski and G Golomb. “Nonviral transfer technology techniques: Sustained delivery and expression of DNA encapsulated in polymeric nanoparticles,” *Gene Therapy*, **7**:1896–1905, 2000.
- G Corell, GR Coatney, JW Field, and J Singh. Chemotherapy of malaria, WHO Monograph Series No. 27, World Health Organization, Geneva, 18–19, 1955.
- J Crank. ***The Mathematics of Diffusion***, Clarendon Press: Oxford 1975.
- DL Doolan, M Sedegah, RC Hedstrom, P Hobart, Y Charoenvit and SL Hoffman. “Circumventing genetic restriction of protection against malaria with multigene DNA immunization: CD8⁺ T-cell-, interferon γ -, and nitric oxide-dependent immunity,” *The J. Experimental Medicine*, **183**:1739–1746, 1996.
- TH Ermack, EP Dougherty, HR Bhagat, Z Kabok, and J Pappo. “Uptake and transport of copolymer biodegradable microspheres by rabbit Peyer’s Patch M cells,” *Cell Tissue Res.*, **279**: 433–436, 1995.

- MJ Gardner, H Tettelin, DJ Carucci, LM Cummings, L Aravind, EV Koonin, S Shallom, T Mason, K Yu, C Fujii, J Pederson, K Shen, J Jing, C Aston, Z Lai, DC Schwartz, M Perteza, S Salzberg, L Zhou, GG Sutton, R Clayton, O White, HO Smith, CM Fraser, MD Adams, JC Venter, and SL Hoffman. "Chromosome 2 sequence of the human malaria parasite *Plasmodium falciparum*," *Science*, **282**:1126–1132, 1998.
- S Hamada and HD Slade. *Microbiol. Rev.*, **44**:331–384, 1980.
- SL Hoffman and LH Miller. Perspectives on malaria vaccine development, Chapter 1 in *Malaria Vaccine Development: A Multi-Immune Response Approach*, ed: SL Hoffman, *American Society for Microbiology*, Washington DC, 1–13, 1996.
- SL Hoffman, DL Doolan, M Sedegah, R Wang, LF Scheller, A Kumar, WR Weiss, TP Le, DM Klinman, P Hobart, JA Norman, and RC Hedstrom. "Toward clinical trials of DNA vaccines against malaria," *Immunology and Cell Biology*, **75**:376–381, 1997.
- SL Hoffman, WO Rogers, DJ Carucci, and JC Venter. "From genomics to vaccines: Malaria as a model system," *Nature Medicine*, **4**:(12), 1351–1353, 1998.
- K Kawabata, Y Takakura and M Hashida. "The fate of plasmid DNA after intravenous injection in mice: Involvement of scavenger receptors in its hepatic uptake", *Pharmaceutical Research*, **12**: (6), 825–830, 1995.
- V Labhasetwar, J Bonadio, S Goldstein, W Chen and RJ Levy. "A DNA controlled-release coating for gene transfer: Transfection in skeletal and cardiac muscle", *Journal of Pharmaceutical Sciences*, **87**:(11), 1347–1350, 1998.
- TP Le, KM Coonan, RC Hedstrom, Y Charoenvit, M Sedegah, JE Epstein, S Kumar, R Wang, DL Doolan, JD Maguire, SE Parker, P Hobart, J Norman, and SL Hoffman. "Safety, tolerability and humoral immune responses after intramuscular administration of a malaria DNA vaccine to healthy adult volunteers", *Vaccine*, **18**:1893–1901, 2000.
- L Lunsford, U McKeever, V Eckstein, and ML Hedley. "Tissue distribution and persistence in mice of plasmid DNA encapsulated in a PLGA-based microsphere delivery vehicle", *J. Drug Targeting*, **8**:(1), 39–50, 2000.
- D Luo and WM Saltzman. "Synthetic DNA delivery systems", *Nature Biotechnology*, **18**:33–37, 2000.
- LH Miller and SL Hoffman. "Research toward vaccines against malaria", *Nature Medicine Vaccine Supplement*, **4**:(5) 520–524, 1998.
- DT O'Hagan. "Oral immunization and the common mucosal system," Chapter 1 in *Novel Delivery Systems for Oral Vaccines*, ed: DT O'Hagan, CRC Press:FL, 1–27, 1994.
- C Perez, A Sanchez, D Putnam, D Ting, R Langer, and MJ Alonso. "Poly(lactic acid)-poly(ethylene glycol) nanoparticles as new carriers for the delivery of plasmid DNA," *Journal of Controlled Release*, **75**:(I and II) , 211–224, 2001.
- TM Pertmer, MD Eisenbraun, D McCabe, SK Prayaga, DH Fuller, and JR Haynes. "Gene gun-based nucleic acid immunization: elicitation of humoral

- and cytotoxic T lymphocyte responses following epidermal delivery of nanogram quantities of DNA," *Vaccine*, **13**:(15), 1427–1430, 1995.
- PL Ritger, NA Peppas. "A simple equation for description of solute release 1. Fickian and Non-Fickian release from non-swellable devices in the form of slabs, spheres, cylinders, or discs," *J. Controlled Release*, **5**, 23-26, 1987.
 - M Sedegah, TR Jones, M Kaur, R Hedstrom, P Hobart, JA Tine, and SL Hoffman. "Boosting with recombinant vaccinia increases immunogenicity and protective efficacy of malaria DNA vaccine," *Proc. Nat. Acad. Sci., USA*, **95**:7648–7653, 1998.
 - M Sedegah, W Weiss, JB Sacci, Jr., Y Charoenvit, R Hedstrom, K Gowda, VF Majam, J Tine, S Kumar, P Hobart, and SL Hoffman. "Improving protective immunity induced by DNA-based immunization: Priming with antigen and GM-CSF-encoding plasmid DNA and boosting with antigen-expressed recombination poxvirus," *The Journal of Immunology*, **164**:5905–5912, 2000.
 - M Singh, M Briones, DT O'Hagan. "A novel bioadhesive intranasal delivery system for inactivated influenza vaccines." *Journal of Controlled Release*, **70**: 267-276, 2001.
 - DJ Smith, DJ Trantolo, WF King, EJ Gusek, PH Fackler, JD Gresser, VL DeSouza, and DL Wise. "Induction of secretory immunity with bioadhesive poly (D,L-lactide-co-glycolide) microparticles containing streptococcus sobrinus glucosyltransferase," *Oral Microbiology and Immunology*, **15**:124–130, 2000.
 - JA Stoute, M Slaoui, G Heppner, P Momin, KE Kester, P Desmons, B Wellde, N Garcon, U Krzych, M Marchand, WR Ballou, and JD Cohen. "A preliminary evaluation of a recombinant circumsporozoite protein vaccine against *Plasmodium falciparum* malaria," *The New England Journal of Medicine*, **336**:86–91, 1997.
 - C Thomason, G Corradin, Y Men, HP Merkle, and B Gander. "Tetanus toxoid and synthetic malaria antigen containing poly(lactide)/poly(lactide-co-glycolide) microspheres: Importance of polymer degradation and antigen release for immune response," *J. Controlled Release*, **41**:131–145, 1996.
 - AM Tinsley-Bown, R Fretwell, AB Dowsett, SL Davis, and GH Farrar. "Formulation of poly(D,L-lactic-co-glycolic acid) microparticles for rapid plasmid DNA delivery," *J. Controlled Release*, **66**:229–241, 2000.
 - DJ Trantolo, JD Gresser, L Yang, DL Wise, JF Smith, and PJ Giannasca. "Delivery of vaccines by biodegradable polymeric microparticles with bioadhesion properties", *Proceedings of the Fifth World Congress, Chemical Engineering*, 1996.
 - GE Visscher, RL Robinson, HV Mauling, JW Fong, JE Pearson, and GJ Argentieri. "Biodegradation and tissue reaction to 50:50 poly(D,L-lactide-co-glycolide) microcapsules," *J. Biomedical Materials Research*, **19**:349–365, 1985.
 - R Wang, DL Doolan, TP Le, RC Hedstrom, KM Coonan, Y Charoenvit, TR Jones, P Hobart, M Margalith, J Ng, WR Weiss, M Sedegah, C deTaisne, JA Normal, and SL Hoffmnn. "Induction of antigen-specific cytotoxic T lymphocytes in humans by a malaria DNA vaccine," *Science*, **282**:476–479, 1998.

- R Wang, DL Doolan, Y Charoenvit, RC Hedstrom, MJ Gardner, P Hobart, J Tine, M Sedegah, V Fallarme, JB Sacci, Jr., M Kaur, DM Klinman, SL Hoffman, and WR Weiss. "Simultaneous induction of multiple antigen-specific cytotoxic T lymphocytes in nonhuman primates by immunization with a mixture of four *Plasmodium falciparum* DNA plasmids," *Infection and Immunity*, **66**:(9), 4193–4202, 1998.
- B Wizel, R Houghten, P Church, JA Tine, DE Lanar, DM Gordon, WR Ballou, A Sette, and SL Hoffman. "HLA-A2-restricted cytotoxic T lymphocyte responses to multiple *Plasmodium falciparum* sporozoite surface protein 2 epitopes in sporozoite-immunized volunteers," *J. Immunology*, **155**:765–775, 1995.

APPENDICES

APPENDIX A

NMRC Protocol for Mouse Immunization

General Procedures:

a. Restraint:

Mice will be placed individually in a container (slotted beaker) which allows for isolation of the tail for bleeding or intravenous injection with parasites (challenge) or other reagents (eg anti-asialo GM1 antiserum). Mice to be injected intraperitoneally (eg monoclonal antibody [mAb] treatment) or treated orally (eg aminoguanidine treatment) will be restrained by hand.

b. Injections/treatments:

(i) intraperitoneally (i.p.): mice will be injected intraperitoneally with a volume of 200 ul using a tuberculin syringe and a 26 gauge needle

(ii) intravenous (i.v.) (parasite challenge with infectious sporozoites or parasitized red blood cells, or other reagents to assess immune mechanisms eg anti-asialo GM1 antibodies to deplete natural killer cells [NK cells]): mice will be heated under a heat lamp (with continual monitoring to ensure that they do not overheat) and then injected intravenously in the tail-vein with a volume of 200 ul using a tuberculin syringe and a 26 gauge or 29.5 gauge needle.

(iii) intramuscular (i.m.) (plasmid DNA): mice will be injected intramuscularly in the tibialis anterior muscle with plasmid DNA expressing the gene under study, or plasmid DNA without the inserted gene (control DNA), at a concentration of 1 mg/ml in a total volume of 50 ul per muscle, using a tuberculin syringe and a 29.5 gauge needle.

For intramuscular injections, we routinely use a disposable sterile 0.3 ml insulin syringe and 28G 1/2 needle (Becton-Dickenson, Rutherford, NJ) which is fitted with a plastic collar cut from a micropipette tip (yellow tip). The collar length is adjusted to limit the needle tip penetration to a distance of about 2 mm into the central part of the muscle. A depth of 2 mm was determined as optimal for intramuscular administration of plasmid DNA by researcher who pioneered the technique and who investigated various parameters including route of administration, osmotic pressure, buffer/solution, etc [J. A. Wolff, et al., *Science* **247**, 1465-1468 (1990)]. This type of device has been used extensively for intramuscular injections with plasmid DNA by investigators in our Program as well as elsewhere, and we and others have confirmed using dyes and other markers that the injection is intramuscular and not subcutaneous.

(iv) orally (aminoguanidine) (note: not proposed in studies herein): mice will be treated orally via gastric lavage with a volume of 200-500 ml aminoguanidine using a gastric lavage needle. Aminoguanidine is a specific inhibitor of the inducible isoform of nitric oxide synthase (iNOS) (Misko et al. *Eur. J. Pharmacol.* 233:119-125).

c. Biosamples

Blood will be collected 10-14 days post immunization, by making a small cut on the ventral side of the tail with a sterile razor blade. The maximum volume obtained at each bleeding will be 300 ul. Prior to bleeding, the mouse will be warmed under an incandescent bulb to improve circulation and the tail will be wiped with alcohol and dried with sterile gauze. Bleeding will be stopped by pressing the wound with sterile gauze. Control of the tail is achieved by utilizing a containment system as described above. Alternatively, blood will be collected by cardiac puncture as a terminal procedure, in accordance with recommendations by WRAIR Department of Veterinary Medicine. The method of euthanasia will be by CO₂ vapor inhalation followed by cervical dislocation.

Anesthesia will not be employed for tail artery/vein bleeds, anesthesia (CO₂ vapor inhalation) will be used for cardiac puncture. Splenocytes, liver cells, lymph node cells, and bone marrow cells will be collected from mice euthanized by CO₂ vapor inhalation followed by cervical dislocation, in accordance with recommendations by WRAIR Department of Veterinary Medicine.

APPENDIX B

NMRC Protocol for ELISA Assay

SOP - ELISA (mouse)**A. Reagents and supplies:**

- 1) Phosphate Buffered Saline (PBS), 1X concentration, Cat#P311-00 (Biofluids, Inc. Rockville, MD)
- 2) Tween-20 Cat#P1371 (Sigma Chemical Co., St Louis, MO)
- 3) Carnation, Nonfat dry milk (NFD), (Nestle Food Co., Glendale, CA)
- 4) Detecting antibodies: Horse radish peroxidase (HRP)-labeled antibodies (all from Kirkegaard & Perry Laboratories (KPL), Gaithersburg, MD]
 - a. HRP-labeled goat anti-mouse IgG (H+L) Cat#074-1806
 - b. HRP-labeled goat anti-mouse IgM (μ) Cat#074-1803
- 5) ABTS peroxidase substrate reagents (KPL):
 - a. ABTS substrate solution A, Cat# 50-64-02
 - b. ABTS substrate solution B (H_2O_2), Cat#50-65-02
- 6) Stop solution (KPL Cat# 50-85-02): 1% Sodium dodecyl sulfate (SDS) in distilled water
- 7) Immunolon II flat bottom micro-titer plates, Cat#0110-103-455 (Dynatech Laboratory Inc., Chantilly, VA)
- 8) Capture antigen (e.g., rec PyCSP protein)
- 9) Positive control sera (e.g., NYS1)

B. Assay Procedure:

- 1) Diluted stock solution of each antigen in 1X concentration of PBS, PH 7.2 to optimal the concentration (previously determined against the positive and negative control serum samples).
- 2) Coat each well of the 96 well, flat-bottom, Immunolon II plates with 50 μ l of optimal concentration of each antigen and incubate the plates for 6 hr at room temperature.
- 3) Wash the antigen wells 3 times with 200 μ l of 0.05% Tween-20 in PBS (**Wash Buffer**), 1 minute each wash, using an Automated Skan Washer 300 (Skatron Instrument, Sterling, VA) (or wash by hand 5 min each wash on a low speed shaker).
- 4) Block the wells overnight at 4°C with 200 μ l of 5% nonfat dry milk in PBS (**Blocking Buffer**), then wash the wells 3 times with Wash Buffer as above.
- 5) Prepare twofold serial dilutions (beginning from 1:50 or 1:100) of the tested and the control serum samples in 3% nonfat dry milk in PBS (**Diluting Buffer**).
- 6) Add in quadruplicate 50 μ l of serum dilutions to each antigen well and incubate the plates for 2 hr at room temperature.
- 7) Wash the wells 3 times with Wash Buffer as above.
- 8) Add to each well 50 μ l of HRP-labeled antibodies diluted 1:2000 in **Blocking Buffer** and incubate the plates for 1hr at room temperature.
- 9) Wash the wells 3 times with Wash Buffer as above.
- 10) Add to each well 100 μ l of a substrate solution containing equal volume of ABTS substrate solution A and B.
- 11) Incubate the plates 20 minutes at room temperature.

- 12) Add to each well 100 μ l of stop solution and measure the optical density at OD410 nm, by using an ELISA Automate reader MR5000 (Dynatech, Chantilly, VA). The mean OD readings of quadruplicate assays are recorded.

The results are reported as OD units. An OD unit is the reciprocal of the serum dilution at which the mean OD reading is 0.5.

APPENDIX C

NMRC Protocol for LPA Assay

FEB 03

SOP - Lymphoproliferation Assay

A. MATERIALS:

1. Complete culture medium.
2. Rec. protein or synthetic peptide immunogens.
3. Concanavalin A ()
4. 3H-methyl thymidine (Dupont NEN)
5. Liquid scintillation counter (Beckman LS6800)

B. METHODS:

1. Isolate splenocytes. Resuspend in complete culture medium at a concentration of $2-4 \times 10^6$ cells/ml.
2. Culture, in quadruplicate, at a concentration of $2-4 \times 10^5$ cells/well in a volume of 0.2 ml complete medium in a round-bottom 96-well tissue culture plate, in the presence of 10 μ g/ml of rec. protein or peptide, without protein or peptide (medium control; 8-12 wells/subject), or with mitogen (con A at 2.5 μ g/ml) for 4-6 d at 37°C in an atmosphere of 5% CO₂.
3. Pulse wells with 1.0 μ Ci 3H-methyl thymidine (Dupont NEN) for 16-18 hours, once optimal proliferation is observed macroscopically (inverted microscope).
4. Harvest and assess 3H uptake by liquid scintillation spectroscopy (Beckman LS6800).
5. Express results as counts per minute (c.p.m.) or as a stimulation index (S.I.; c.p.m test sample/ c.p.m. medium control without peptide). A response is considered positive if the SI >2.0.

APPENDIX D

SRI Protocol for ELISPOT Assay

ELISPOT Assays for Measuring Murine Cytokines

Method

ELISPOT assays for IFN- γ were performed using a commercially available kit (Cell Sciences Inc, MA). Mice spleens were removed aseptically and homogenized in complete RPMI 1640 growth medium containing 5% FBS, 0.5% gentamicin and 5.0 % glutamine. Briefly, 1×10^5 splenocytes were added (in triplicate) to PVDF-bottomed 96-well plates pre-coated with anti-mouse IFN- γ capture Mab and stimulated with the appropriate protein/peptide antigens at 1-10 $\mu\text{g/ml}$ for 18 hours at 37 $^{\circ}\text{C}$. Splenocytes stimulated with 10 $\mu\text{g/ml}$ Concanavalin A (Con A) or Staphylococcus Endotoxin B (SEB) are included as positive controls. We also use PMA and ionomycin, a potent stimulator IFN- γ production in mouse splenocytes. Unstimulated splenocytes served as negative control cells. After washing, wells were incubated with biotinylated anti-IFN- γ detector antibody followed by streptavidin conjugated to alkaline phosphatase. Individual IFN- γ producing cells were visualized by the addition of BCIP/NTB as substrate. Purple spot-forming cells (SFC) were enumerated manually using a stereoscopic microscope and expressed as IFN- γ SFC/ 10^5 splenocytes.

Results and Summary

Here is an example of the type of data that we generate using donor spleens from six normal BALB/c mice. IFN- γ -secreting splenocytes were detected in response to *in vitro* stimulation with Con A and SEB by the method described above. The results for these studies are illustrated in Figure 1.

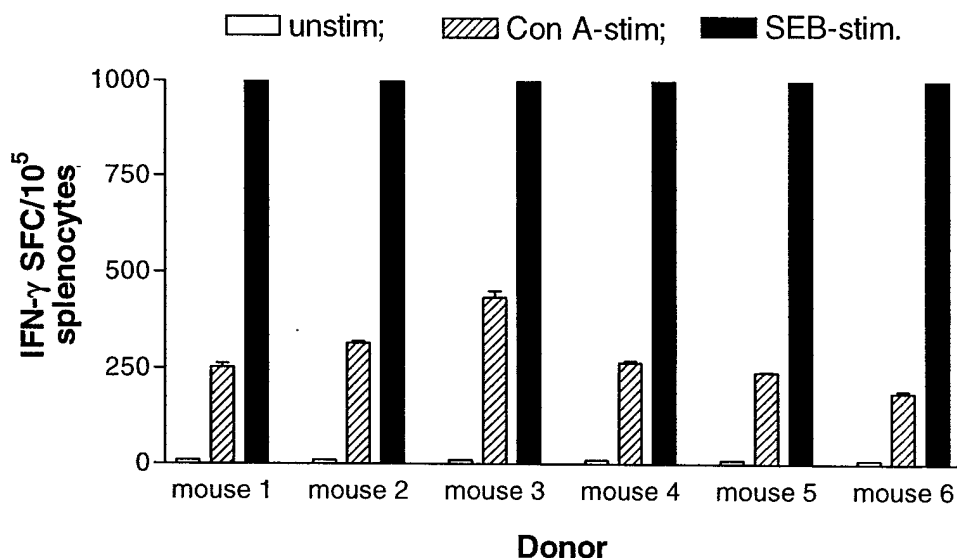

Figure 1. Mouse IFN- γ ELISPOT Assay. Detection of IFN- γ SFC/ 10^5 splenocytes from six donor mice in response to *in vitro* stimulation for 18 hours with Con A (hatched bars) and SEB (solid bars). Unstimulated splenocytes are shown as open bars. Solid bars were >1000 IFN- γ SFC/ 10^5 .

Stimulation with Con A induced the production of IFN- γ in splenocytes from all of six mice with mean IFN- γ SFC/ 10^5 splenocytes ranging from approximately 200-400. In contrast, SEB-stimulation was more efficient at inducing IFN- γ production with mean IFN- γ SFC/ 10^5 splenocytes >1000 in all of six donor mice. Thus, using a commercially available ELISPOT kit and applying appropriate stimuli, we have successfully detected IFN- γ -secreting cells in mice splenocytes.

APPENDIX E

TABLES

Table 1: Experimental Design for Milestone 2 Study

Table 2: Size of Biopolymeric Particles

Table 3: Antibody Titers measured in Pooled Serum using Immunofluorescence
Antibody Test

Table 1: Experimental Design for Milestone 2 Study

Group	Group Size	Vaccine Dose (μg)	Delivery Vehicle
1	8	0.5	Saline
2	8	5	Saline
3	8	50	Saline
4	8	0.5	Polymer suspension
5	8	5	Polymer suspension
6	8	50	Polymer suspension
7	8	No vaccine	Polymer suspension

Table 2: Size of Biopolymeric Particles

Property	Based on Number of Particles	Based on Particle Mass
Mean (μm)	9.8	22.9
Standard Deviation (μm)	6.0	9.4
Median (μm)	7.9	21.9

Table 3: Antibody Titers measured in Pooled Serum using Immunofluorescence Antibody Test

Group	Time (Weeks)	Vaccine Dose (μg)	Delivery Vehicle	Titer
1	8	0.5	Saline	Negative
2	8	5	Saline	40
3	8	50	Saline	640
4	8	0.5	Polymer suspension	Negative
5	8	5	Polymer suspension	Negative
6	8	50	Polymer suspension	20
7	8	No vaccine	Polymer suspension	Negative
Control	-	NYS1		2,560
3	6	50	Saline	640
6	6	50	Polymer suspension	20-40

APPENDIX F

FIGURES

- Figure 1: Measured Particle Size Distribution
- Figure 2: VR2578 Release from PLGA Particles
- Figure 3: Cell-mediated immune responses to PyCSP 280-288 K^d-restricted epitope and ConA in mice immunized by saline delivery or mock-immunized mice as measured by ELISPOT assays.
- Figure 4: Relationship between vaccine dose when delivered with saline and the induction of CMI responses in BALB/c mice as measured by ELISPOT assays.
- Figure 5: Cell-mediated immune responses to PyCSP 280-288 K^d-restricted epitope and ConA in mice immunized by polymer delivery or mock-immunized as measured by ELISPOT assays.
- Figure 6: Relationship between vaccine dose when delivered in polymeric microparticles and the induction of CMI responses in BALB/c mice as measured by ELISPOT assays.
- Figure 7: Lymphoproliferative responses in unstimulated, PyCSP 57-70 peptide-stimulated, and PHA-stimulated splenocytes in mice immunized by saline delivery or mock-immunized.
- Figure 8: Lymphoproliferative responses in unstimulated, PyCSP 57-70 peptide-stimulated and PHA-stimulated splenocytes in mice immunized by polymeric microparticle delivery or mock-immunized.
- Figure 9: ELISA Anti-*P. yoelii* antibody levels measured at Week 6 in mice immunized with 0.5 µg or 5.0 µg of VR2578 delivered in saline.
- Figure 10: ELISA Anti-*P. yoelii* antibody levels measured at Week 6 in mice immunized with 50.0 µg VR2578 in saline or mock-immunized.
- Figure 11: ELISA Anti-*P. yoelii* antibody levels measured at Week 6 in mice immunized with 0.5 µg or 5.0 µg of VR2578 delivered in polymeric microparticles.
- Figure 12: ELISA Anti-*P. yoelii* antibody levels measured at Week 6 in mice immunized with 50.0 µg VR578 in polymeric microparticles or mock-immunized.
- Figure 13: ELISA Anti-*P. yoelii* antibody levels measured at Week 8 in mice immunized with 0.5 µg or 5.0 µg of VR2578 delivered in saline.
- Figure 14: ELISA Anti-*P. yoelii* antibody levels measured at Week 8 in mice immunized with 50.0 µg of VR2578 delivered in saline or mock-immunized.
- Figure 15: ELISA Anti-*P. yoelii* antibody levels measured at Week 8 in mice immunized with 0.5 µg or 5.0 µg of VR2578 delivered in polymeric microparticles.
- Figure 16: ELISA Anti-*P. yoelii* antibody levels measured at Week 8 in mice immunized with 50.0 µg of VR2578 delivered in polymeric microparticles or mock-immunized.
- Figure 17: Delivery rate of plasmid vaccine in saline compared to sustained release from PLGA microparticles.

Figure 1: Measured Particle Size Distribution

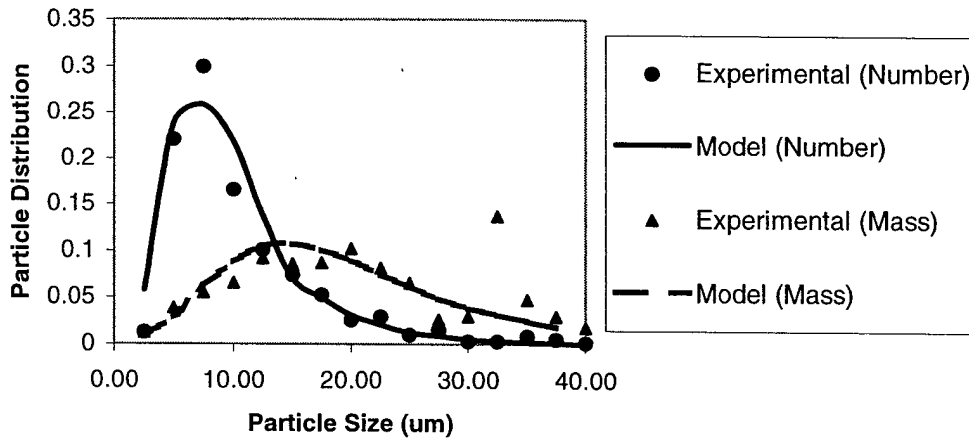
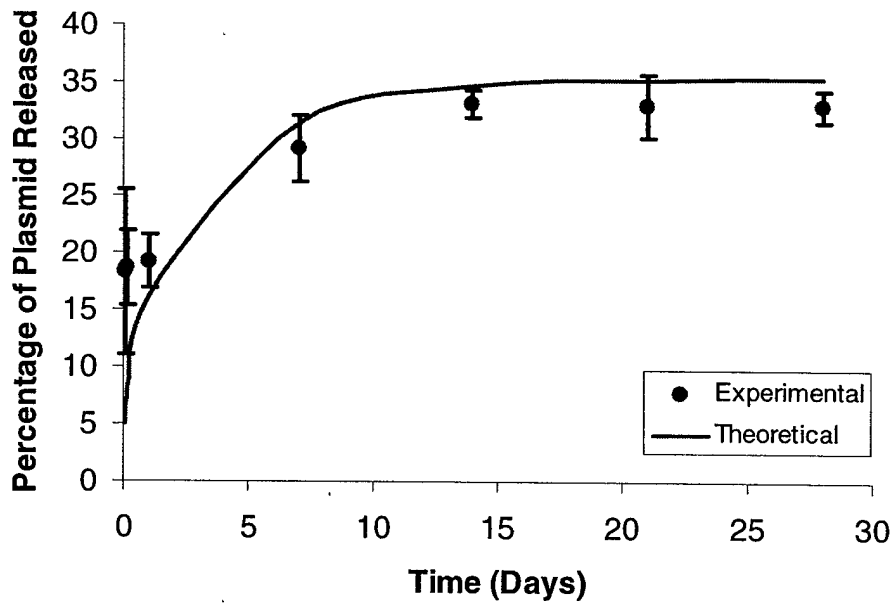

Figure 2: VR2578 Release from PLGA Particles



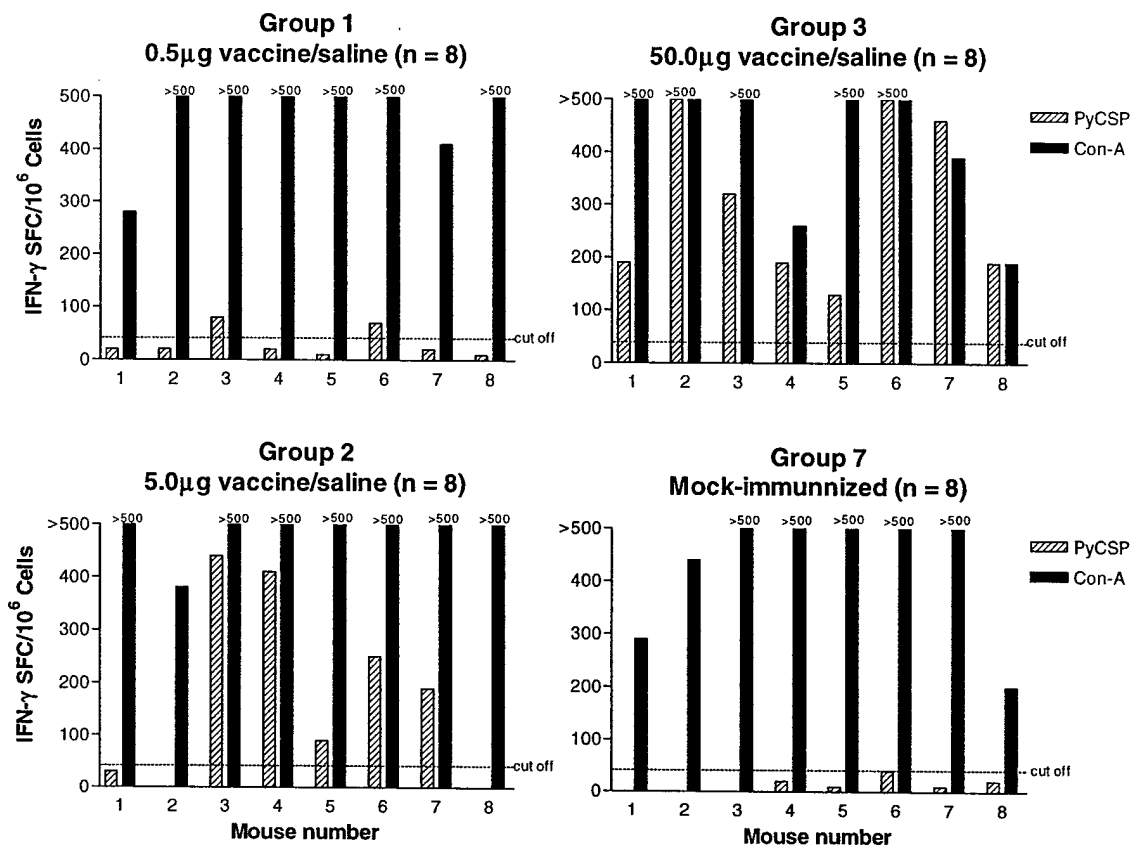

Figure 3: Cell-mediated immune responses to PyCSP 280-288 K^d-restricted epitope (hatched bars) and ConA (solid bars) in mice immunized by saline delivery (Groups 1, 2, and 3) or mock-immunized mice (Group 7) as measured by ELISPOT assays. Results are expressed as number of IFN-γ SFC/10⁶ splenocytes following subtraction of background counts obtained with unstimulated cells.

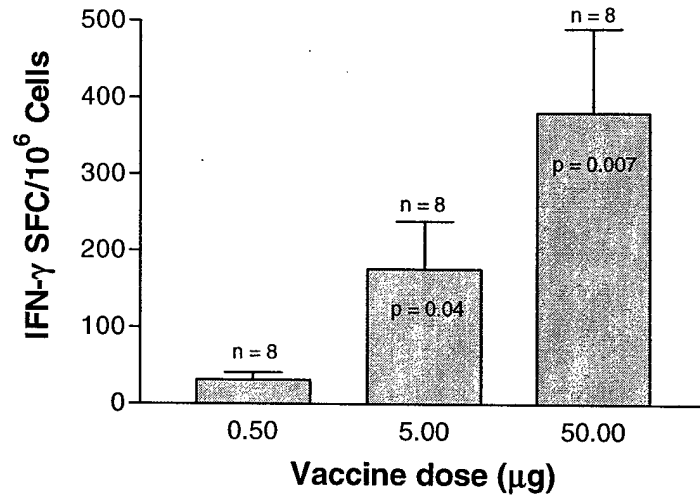

Figure 4: Relationship between vaccine dose when delivered with saline and the induction of CMI responses in BALB/c mice as measured by ELISPOT assays.

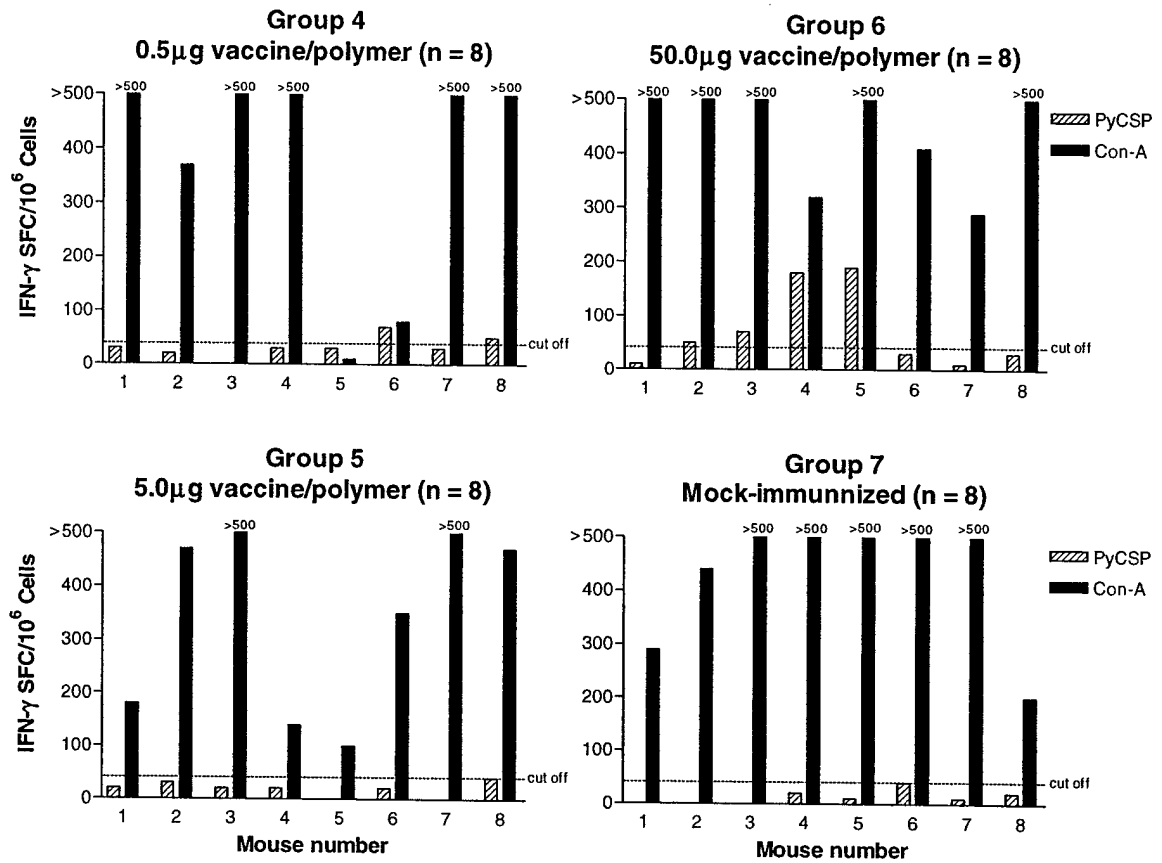

Figure 5: Cell-mediated immune responses to PyCSP 280-288 K^d-restricted epitope (hatched bars) and ConA (solid bars) in mice immunized by polymer delivery (Groups 4, 5, and 6) or mock-immunized (Group 7) as measured by ELISPOT assays. Results are expressed as number of IFN- γ SFC/10⁶ splenocytes after subtracted of background counts obtained with unstimulated cells.

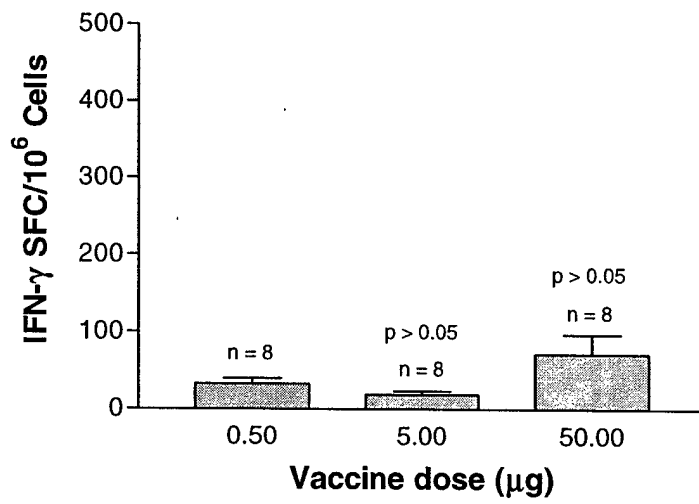

Figure 6: Relationship between vaccine dose when delivered in polymeric microparticles and the induction of CMI responses in BALB/c mice as measured by ELISPOT assays.

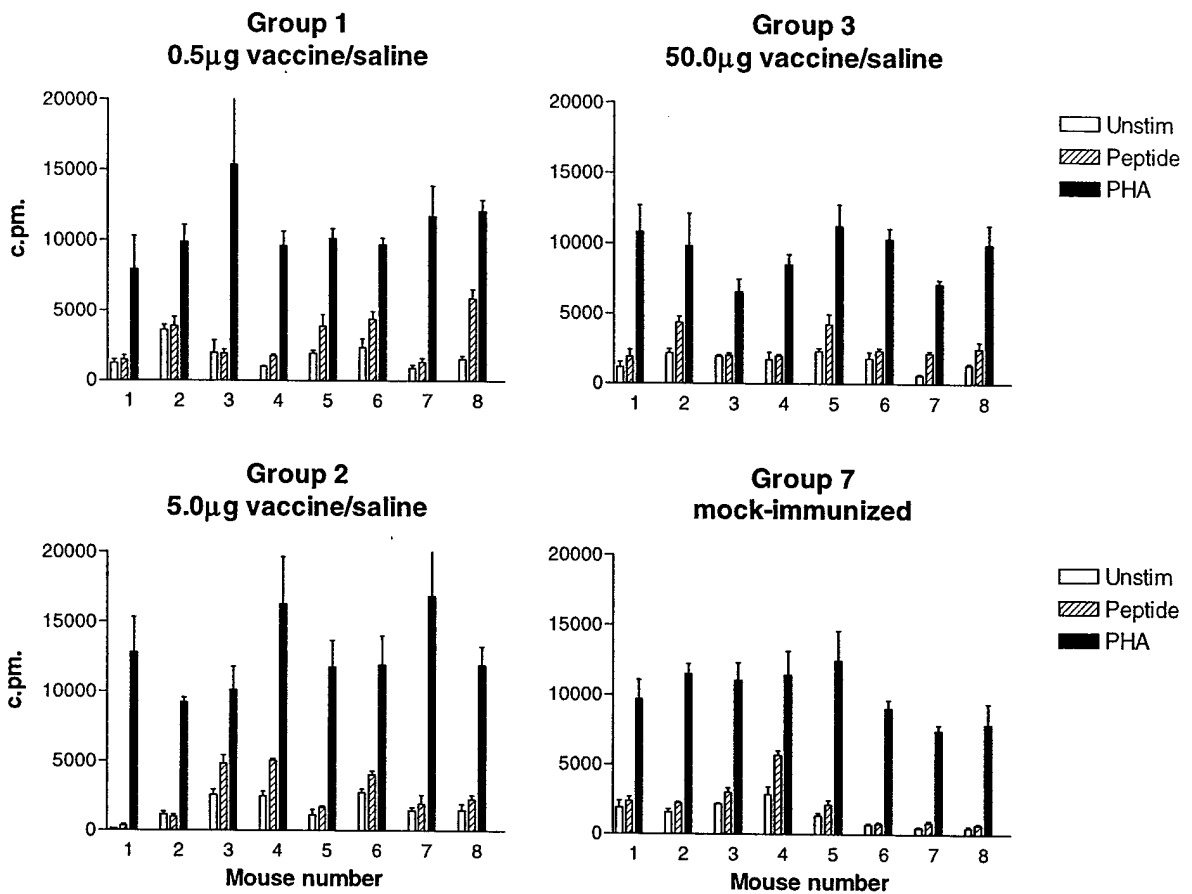

Figure 7: Lymphoproliferative responses in unstimulated (open bars), PyCSP 57-70 peptide-stimulated (hatched bars), and PHA-stimulated (solid bars) splenocytes in mice immunized by saline delivery (Groups 1, 2, and 3) or mock-immunized (Group 7). Results are expressed as c.p.m. of ^3H -thymidine incorporated into cellular DNA.

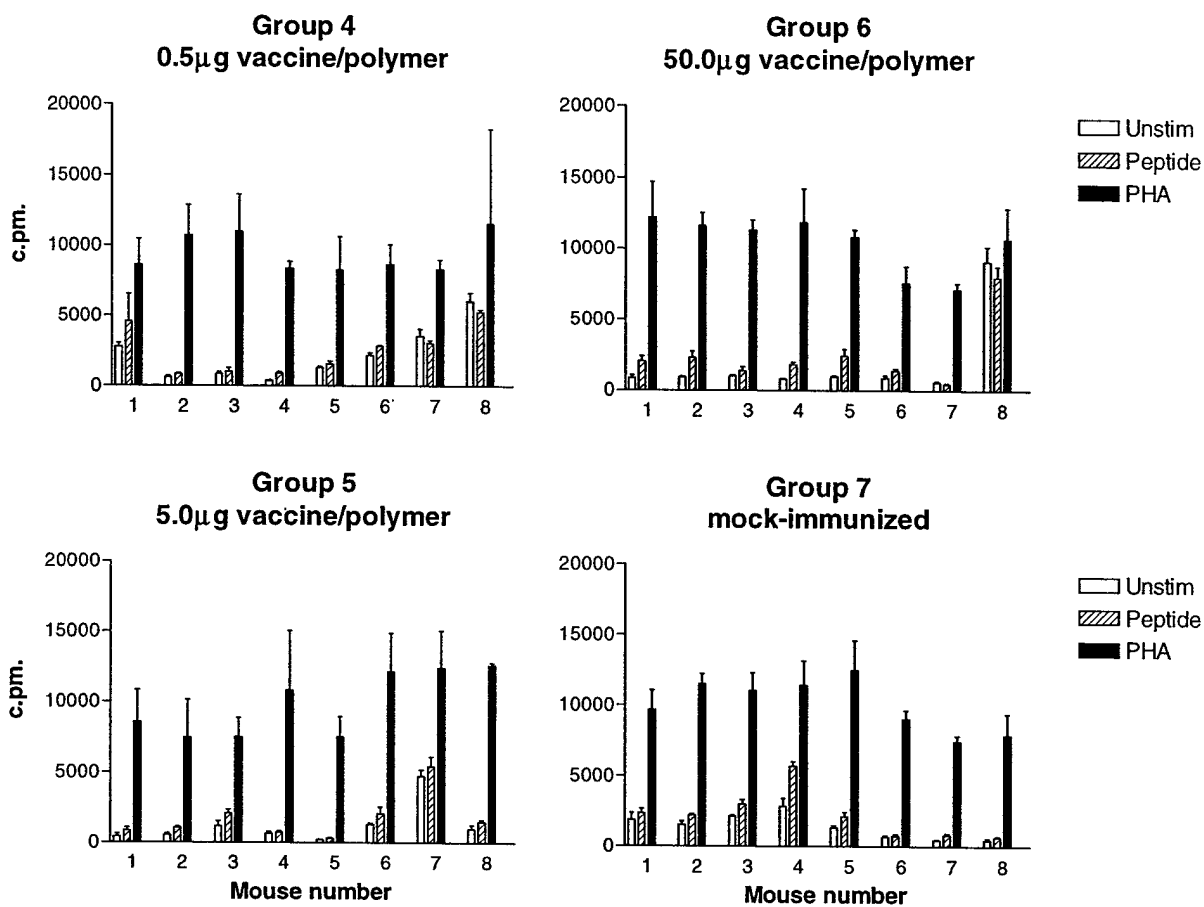

Figure 8: Lymphoproliferative responses in unstimulated (open bars), PyCSP 57-70 peptide-stimulated (hatched bars) and PHA-stimulated (solid bars) splenocytes in mice immunized by polymeric microparticle delivery (Groups 4, 5, and 6) or mock-immunized (Group 7). Results are expressed as c.p.m. of ^3H -thymidine incorporated into cellular DNA.

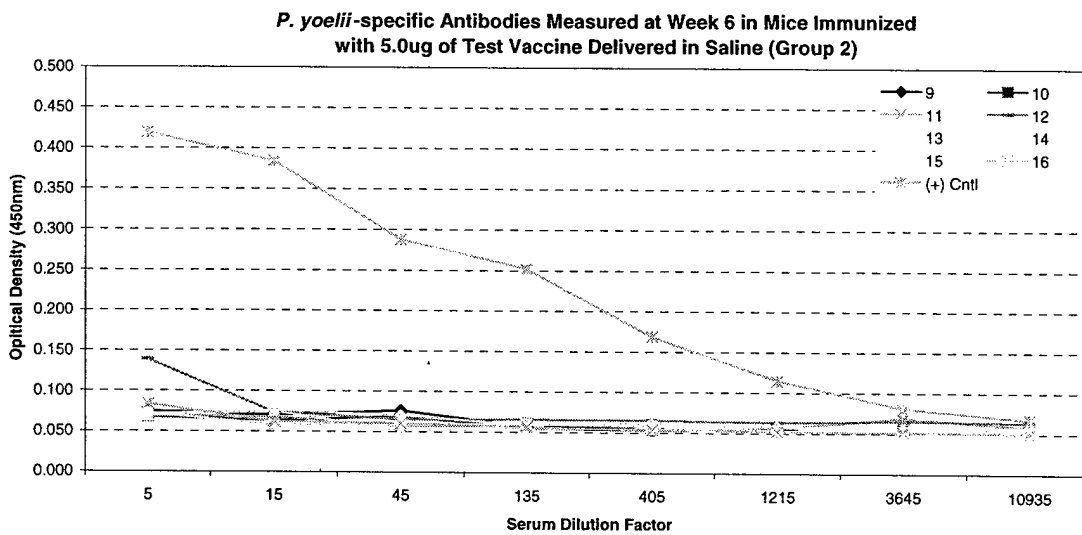
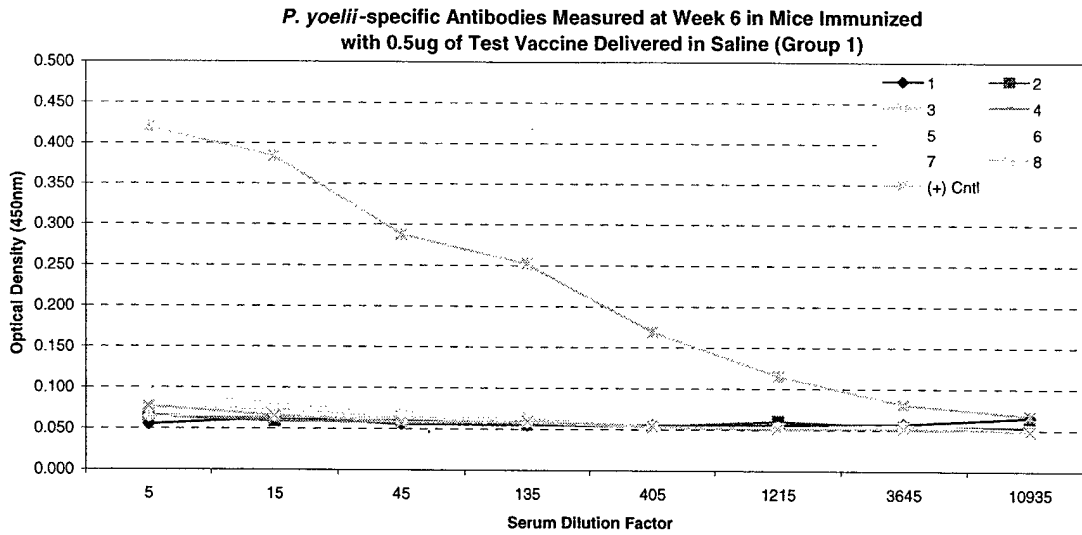

Figure 9: ELISA Anti-*P. yoelii* antibody levels measured at Week 6 in mice immunized with 0.5 μ g (Group 1; top graph) or 5.0 μ g (Group 2; bottom graph) of VR2578 delivered in saline.

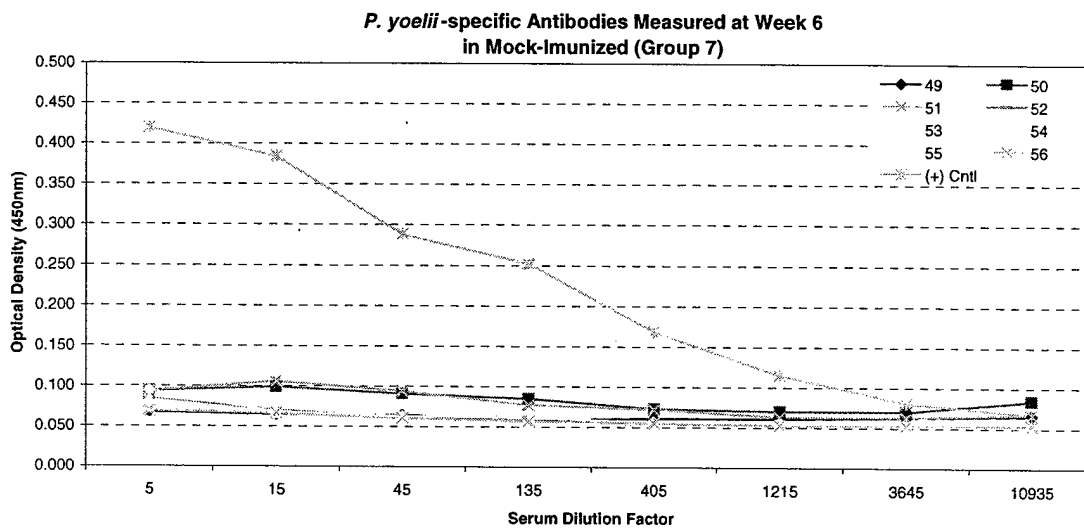
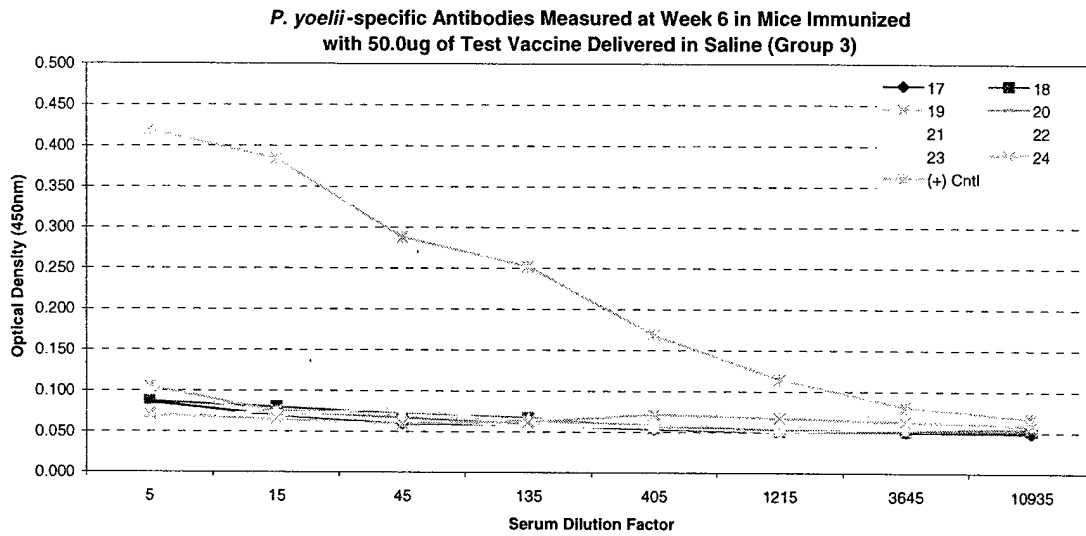

Figure 10: ELISA Anti-*P. yoelii* antibody levels measured at Week 6 in mice immunized with 50.0 μ g VR2578 in saline (Group 3; top graph) or mock-immunized (Group 7; bottom graph).

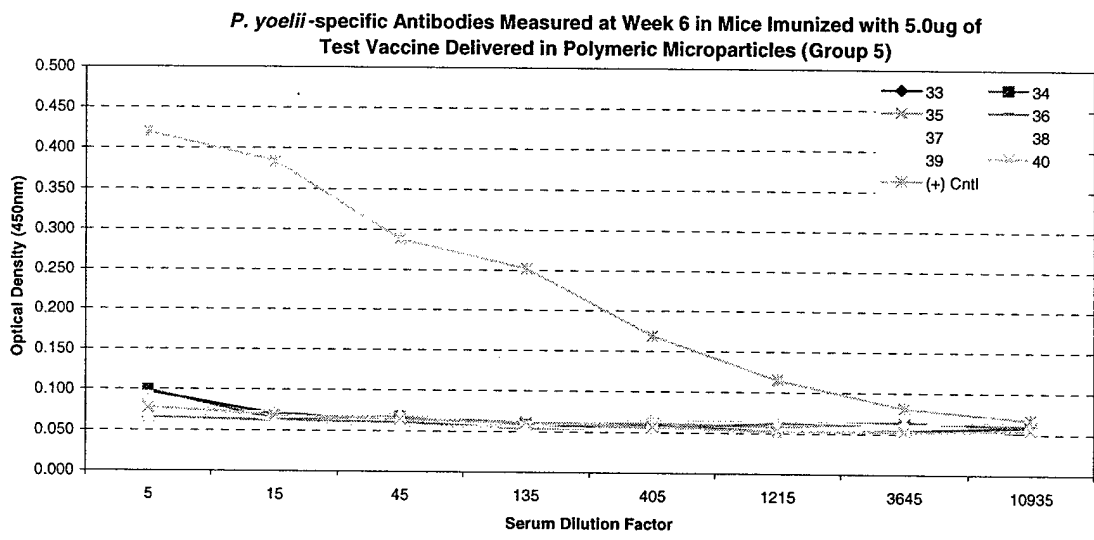
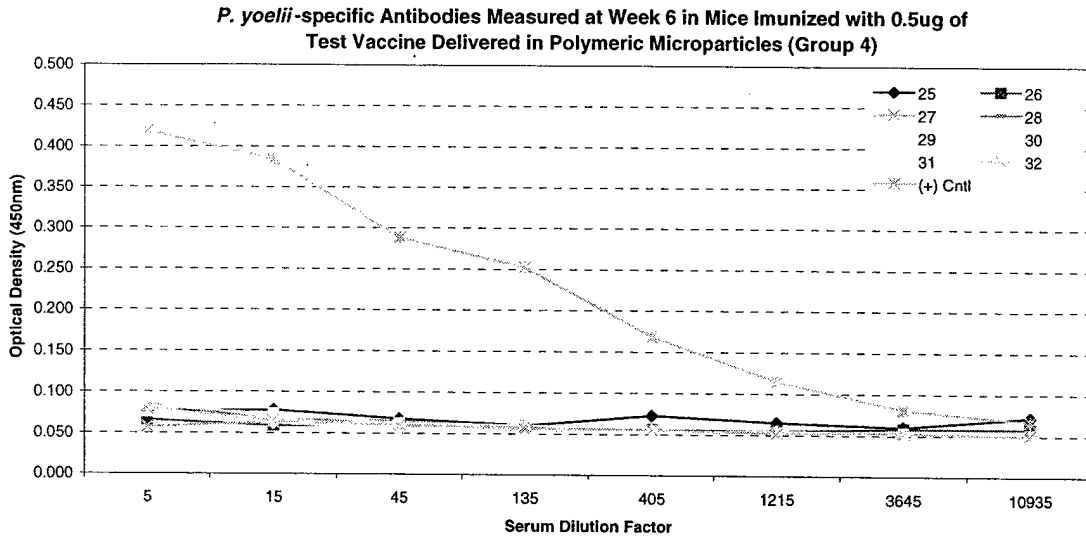

Figure 11: ELISA Anti-*P. yoelii* antibody levels measured at Week 6 in mice immunized with 0.5 μ g (Group 4; top graph) or 5.0 μ g (Group 5; bottom graph) of VR2578 delivered in polymeric microparticles.

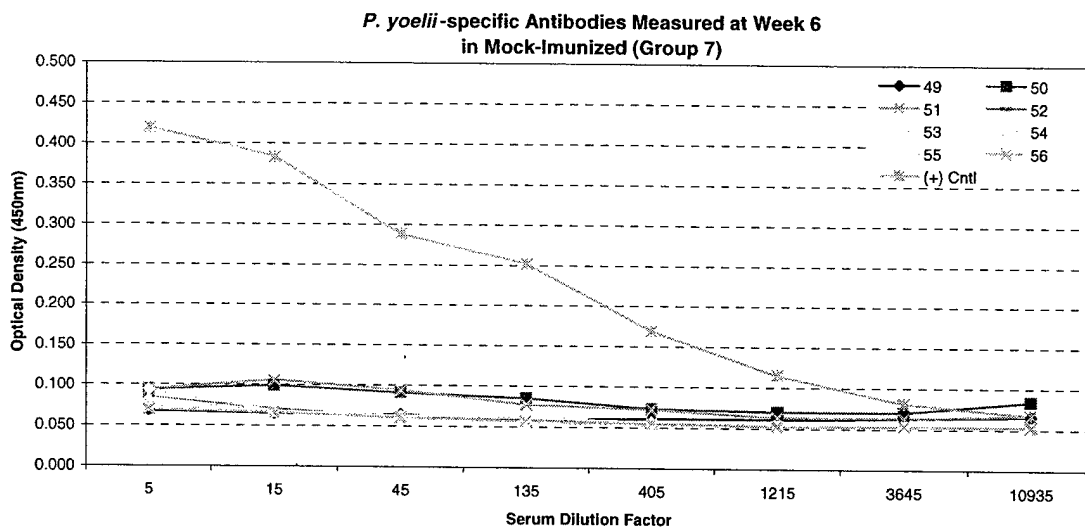
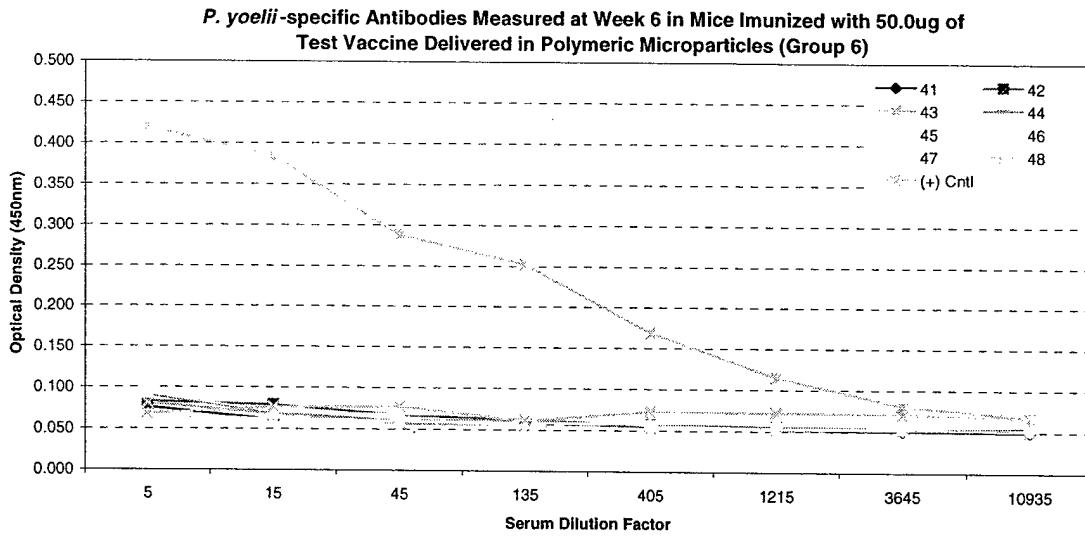

Figure 12: ELISA Anti-*P. yoelii* antibody levels measured at Week 6 in mice immunized with 50.0 μ g VR578 in polymeric microparticles (Group 6; top graph) or mock-immunized (Group 7; bottom graph).

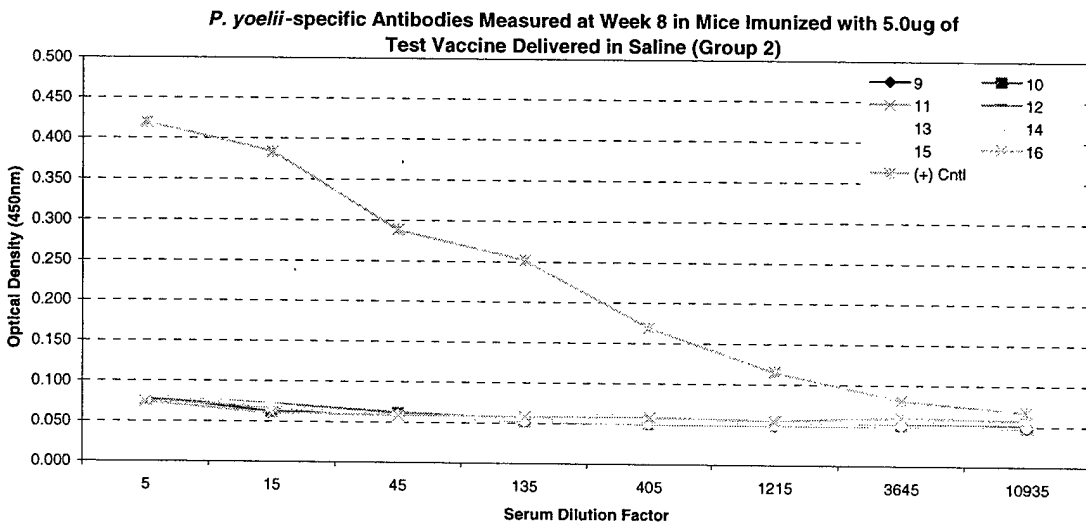
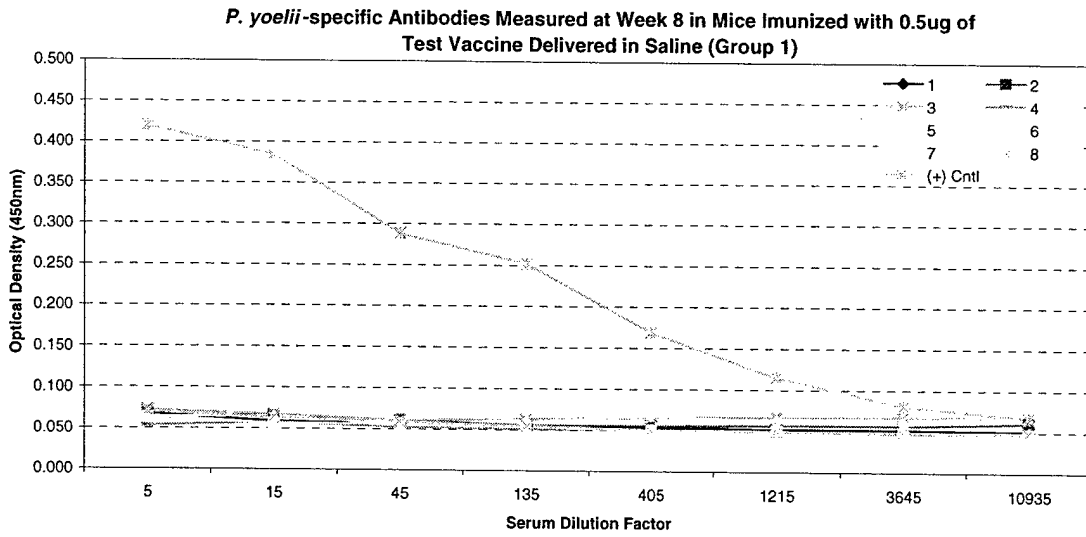

Figure 13: ELISA Anti-*P. yoelii* antibody levels measured at Week 8 in mice immunized with 0.5 μ g (Group 1; top graph) or 5.0 μ g (Group 2; bottom graph) of VR2578 delivered in saline.

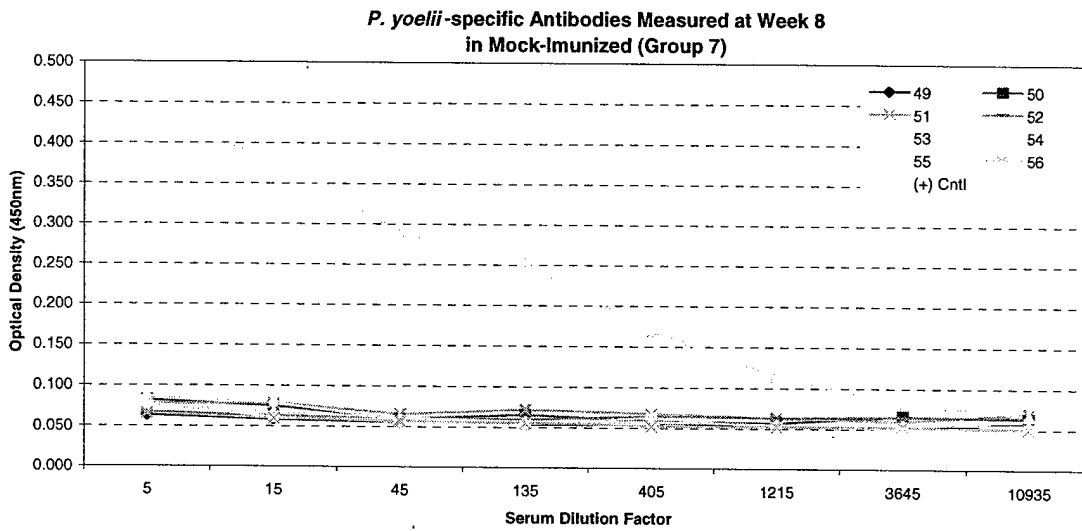
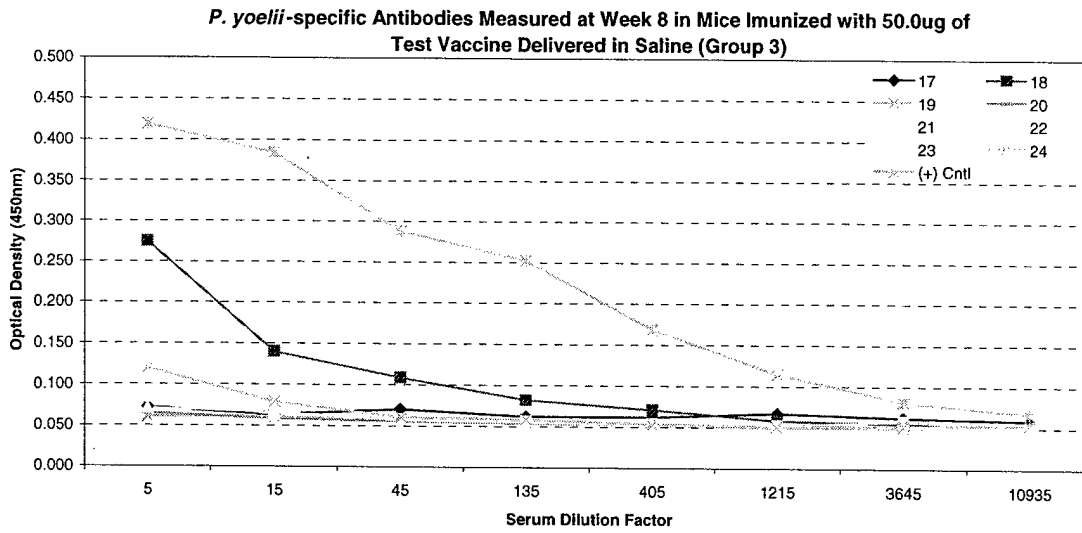

Figure 14: ELISA Anti-*P. yoelii* antibody levels measured at Week 8 in mice immunized with 50.0 μ g of VR2578 delivered in saline (Group 3; top graph) or mock-immunized (Group 7; bottom graph).

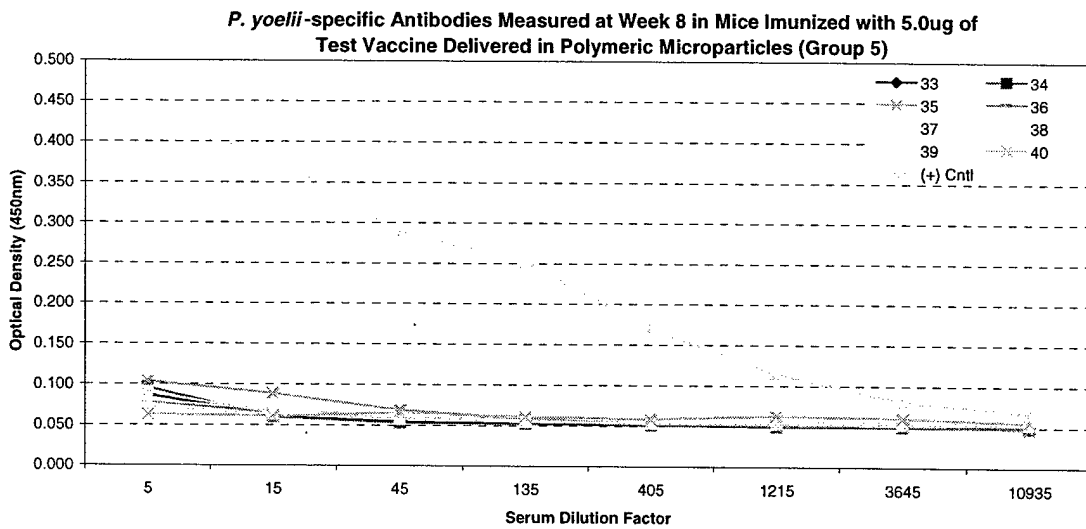
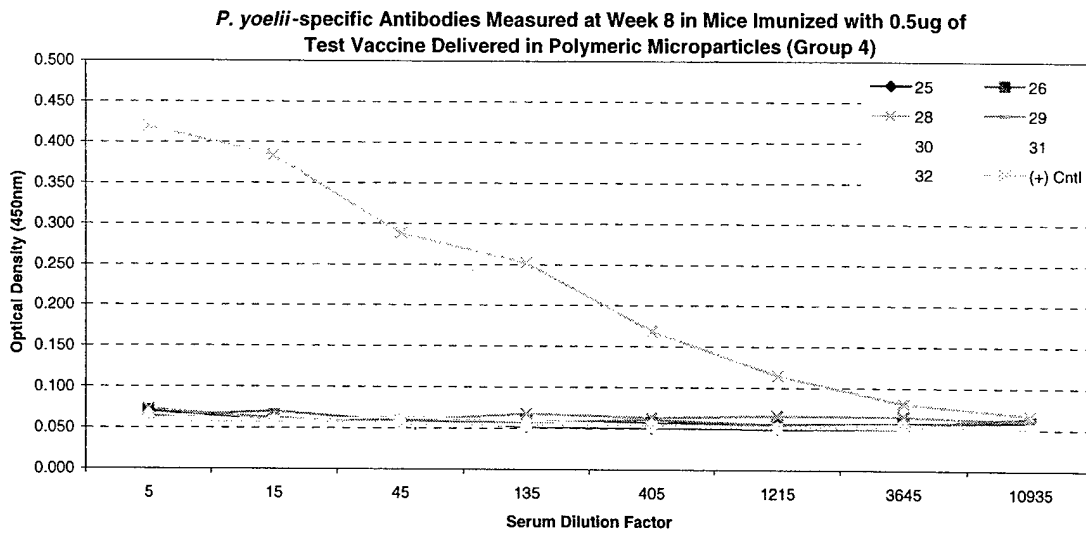

Figure 15: ELISA Anti-*P. yoelii* antibody levels measured at Week 8 in mice immunized with 0.5 μ g (Group 4; top graph) or 5.0 μ g (Group 5; bottom graph) of VR2578 delivered in polymeric microparticles. Note: Due to technical difficulties, serum was not collected from mouse # 27 (Group 4), and therefore was not tested.

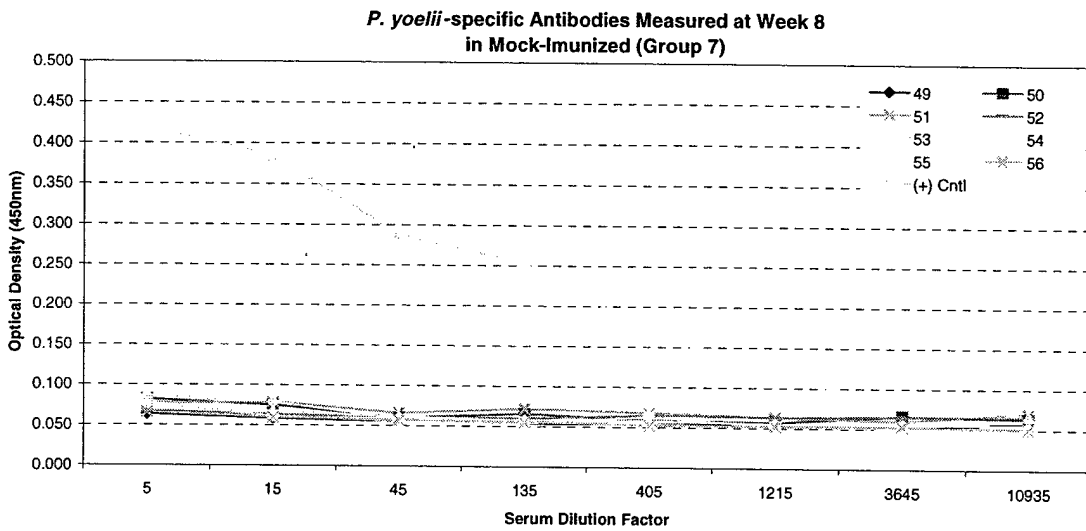
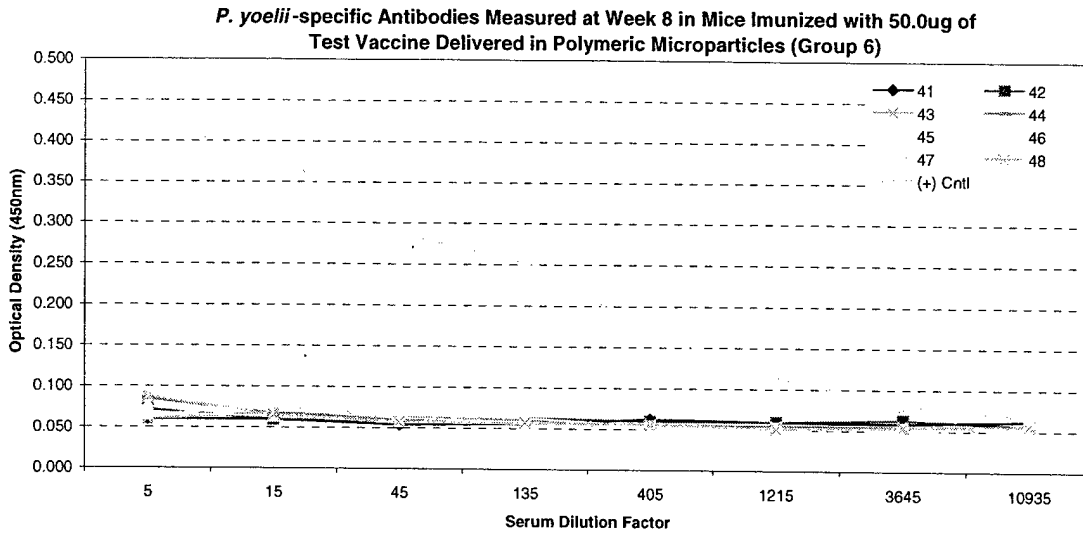

Figure 16: ELISA Anti-*P. yoelii* antibody levels measured at Week 8 in mice immunized with 50.0 µg of VR2578 delivered in polymeric microparticles (Group 6; top graph) or mock-immunized (Group 7; bottom graph).

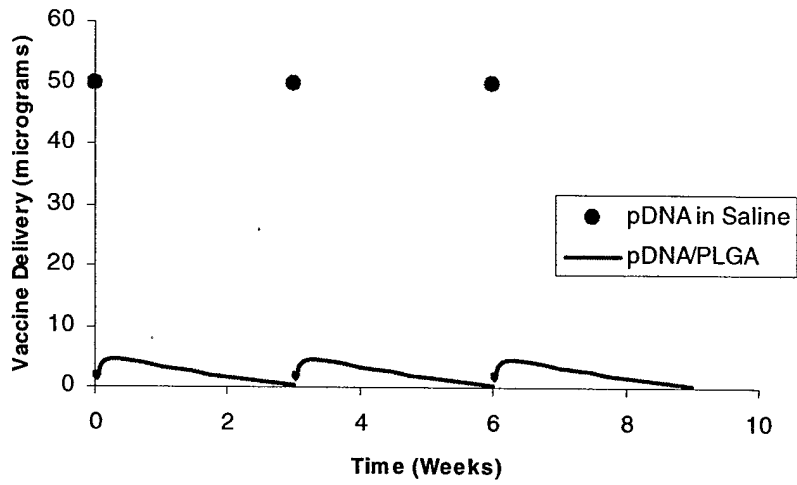

Figure 17: Delivery rate of plasmid vaccine in saline compared to sustained release from PLGA microparticles for a dose of 50 μg . Administration of the plasmid in saline results in immediate availability of the vaccine, where the PLGA formulation controls the availability through delivery of the antigen.

APPENDIX G

CAMBRIDGE SCIENTIFIC, INC. GOOD LABORATORY PRACTICES EQUIPMENT STANDARD OPERATING PROCEDURES

ADJUSTMENT OF ENERPAC HYDRAULIC PRESS (MODEL RR-1006)

**CALIBRATION OF ENERPAC HYDRAULIC PRESS MODEL RR-1006 WITH
LOAD CELL LH 10006**

OPERATION OF ENERPAC HYDRAULIC PRESS, MODEL RR 1006

OPERATION OF TEKMAR A-10 ANALYTICAL MILL

**OPERATION OF POLYSCIENCE MICROPROCESSOR CONTROLLED
SHAKER WATER BATHS**

**OPERATION OF SYNTRON ELECTRIC VIBRATOR WITH USA STANDARD
SIEVE**

PROCEDURE FOR CLEANING SIEVES

**PROCEDURE FOR CLEANING MOLD, RAM, DIE ASSEMBLY BY
SONICATION**

**OPERATION OF FS-30 ULTRASONIC CLEANER FOR REMOVAL OF
POLYMER FROM MOLD ASSEMBLY**

**CSI GLP SOP
No. EQP 1-1**

**CAMBRIDGE SCIENTIFIC, INC.
Good Laboratory Practice Standard Operating Procedure**

File: Protocol
Date: 21 April 1998

**ADJUSTMENT OF ENERPAC HYDRAULIC PRESS
MODEL RR-1006**

Written By: _____ Reviewed By: _____
Signature Date Signature Date

Responsibility of:
Lab supervisor or someone
familiar with technique

Signature Date

Lab Director

Signature Date

SUMMARY:

This GLP SOP describes how to adjust the movable frame of the Enerpac Model RR 1006 Hydraulic Press for use with extrusion molds.

KEY WORDS: Enerpac, Hydraulic Press, adjustment of movable frame, Hydraulic lift

EQUIPMENT:

Enerpac Model RR 1006 Hydraulic Press, Maximum Cylinder Capacity = 100 tons
Effective Cylinder Area: = 20.65 in², Hydra-Lift C215900
The hydraulic lift is used to adjust the frame position (Hydra-Lift C215900) is located on the side of the Enerpac.

PROCEDURE:

1. Unscrew the valve part way.
2. Pull the chain down by hand.
3. Close the valve.
4. Engage a link of the chain in the slot on the side of the moveable frame.
5. Use the crank to lift the frame slightly in order to relieve the pressure on the cylindrical supports.
6. Remove the cylindrical supports from the holes in the vertical beams of the press.
7. To raise the movable frame crank up. For use with the extrusion molds, raise the frame so that there are slightly less than 13 inches between the bottom of the upper flange and top of the lower flange.
8. Place the two cylindrical supports in the third holes from the bottom of the vertical supports.
9. Crack the valve slightly to allow the movable frame to be lowered onto the cylindrical supports.
10. Close the valve. Disengage the chain and slip it behind the bar with the lifting slot.

Cambridge Scientific, Inc.
180 Fawcett Street
Cambridge, MA 02138

CSI GLP SOP
No. EQP 2-1

CAMBRIDGE SCIENTIFIC, INC.
Good Laboratory Practice Standard Operating Procedure

Date: 21 April 1998

CALIBRATION OF ENERPAC HYDRAULIC PRESS
MODEL RR-1006 WITH LOAD CELL LH 10006

Written By: _____ Reviewed By: _____
Signature Date Signature Date

Responsibility of:
Lab supervisor or someone
familiar with technique

Signature Date

Lab Director

Signature Date

SUMMARY:

This GLP-SOP describes maintenance and calibration of the Enerpac Model RR- 1006 Hydraulic Press.

KEY WORDS: Enerpac, Hydraulic, Press, Calibration, Load Cell

EQUIPMENT:

Enerpac Model RR 1006 Hydraulic Press, Enerpac Load Cell LH 10006 (Accuracy, \pm 2% full scale)

PROCEDURE:

1. Check oil level. Oil gauge marker should be in green area. If necessary, fill with Enerpac hydraulic oil HF-100 to HF-104 catalog numbers. (Note: these are identical; the last digit refers only to the container size.)
2. Back out FORCE CONTROL SCREW.
3. If necessary, adjust movable horizontal frame so that there is a 13 inch space between the flanges of the upper and lower I-beams. The cylindrical supports for the movable frame will be in the third hole from the bottom on either side and the lower I-beams (movable frame) will rest on top of the cylinders. (See SOP EQP 1-1)
4. Place the 1.5" steel support plate under hydraulic cylinder
5. Make sure power switch is in OFF position. Plug pump motor to 120 volt, 30 amp, 60 Hz power source. Turn on power.
6. Retract hydraulic cylinder using hand held RETRACT/ADVANCE hand held control.
7. Position Load Cell on the steel plate on the moveable frame.
8. Position the LH-10006 load cell under the cylinder as described for mold in SOP EQP 3-1.
9. Sequentially place force on load cell in 10,000 pound increments as read on the Enerpac gauge, from 10,000 lbs to 180,000 lbs.
10. Record force registered on both load cell and Enerpac Gauge in the format shown below. (Use. Notebook reserved for Enerpac calibration).
11. Plot Load cell reading (y-axis) versus Enerpac Gauge reading (x-axis). Readings should agree to within 2000 lbs.
12. Use this plot when setting extrusion pressure.

Cambridge Scientific, Inc.
180 Fawcett Street
Cambridge, MA 02138

13. Repeat calibration every three months.

CALIBRATION OF LOAD CELL:

Load cell should be sent to Enerpac every six months to check its accuracy.

ENERPAC
Butler, Wisconsin 53007
Tel: (414) 781-6600

Or

Toomey Associates, Inc.
1100 Russell Road
Westfield, MA 01086-0577
Tel: (800) 762-5192
Fax: (413) 568-0066

CALIBRATION OF THE ENERPAC MODEL RR 1006 HYDRAULIC PRESS

Date _____

Data By: _____

Reading on Enerpac Gauge (Pounds)	Force on Calibration Load Cell (Pounds)
10,000	
20,000	
30,000	
40,000	
50,000	
60,000	
70,000	
80,000	
90,000	
100,000	
110,000	
120,000	
130,000	
140,000	
150,000	
160,000	
170,000	
180,000	

CSI GLP SOP
No. EQP 3-1

CAMBRIDGE SCIENTIFIC, INC.
Good Laboratory Practice Standard Operating Procedure

Date: 21 April 1998

OPERATION OF ENERPAC HYDRAULIC PRESS, MODEL RR 1006

Written By: _____ Reviewed By: _____
Signature Date Signature Date

Responsibility of:
Lab supervisor or someone
familiar with technique

Signature Date

Lab Director

Signature Date

SUMMARY:

This GLP-SOP describes the use of the Enerpac Model RR 1006 Hydraulic Press with emphasis on extrusion of PLGA implants.

KEY WORDS: Enerpac, Hydraulic, Press, Extrusion

EQUIPMENT:

Enerpac Model RR 1006 Hydraulic Press

Maximum Cylinder Capacity = 100 tons; Effective Cylinder Area = 20.65 in²

PROCEDURE:

1. Check oil level. Oil gauge marker should be in green area. If necessary, fill with Enerpac hydraulic oil HF-100 to HF-104 catalog numbers. (Note: these are identical; the last digit refers only to the container size.)
2. Back out FORCE CONTROL SCREW.
3. If necessary adjust movable horizontal frame so that there is a 13 inch space between the flanges of the upper and lower I-beams. The cylindrical supports for the movable frame will be in the third hole from the bottom on either side and the lower I-beams (movable frame) will rest on top of the cylinders. (See SOP EQP 1-1)
4. Place the steel support plate under hydraulic cylinder.
5. Make sure power switch is in OFF position. Plug pump motor to 120 volt, 30 amp, 60 Hz power source. Turn on power.
6. Retract hydraulic cylinder using hand held RETRACT/ADVANCE control.
7. Position extrusion mold assembly and heating collars on plate. (See SOP EQP 4-1 for filling and assembly of extrusion mold and heating collars.)
8. Advance cylinder toward mold assembly and adjust mold position so that the die is over the hole in the steel plate and the ram is centered under the hydraulic cylinder. (Note that the FORCE CONTROL SCREW is still adjusted so that no force is applied to the ram.
9. Refer to appropriate SOP for temperature and force conditions required for extrusion to be performed.
10. Adjust force on ram by advancing FORCE CONTROL SCREW to pressure specified in the appropriate SOP Protocol. When force is set, tighten wing nut.

Cambridge Scientific, Inc.
180 Fawcett Street
Cambridge, MA 02138

CSI GLP SOP
No. EQP 4-1

CAMBRIDGE SCIENTIFIC, INC.
Good Laboratory Practice Standard Operating Procedure

Date: 22 April 1998

OPERATION OF TEKMAR A-10 ANALYTICAL MILL

Written By: _____ Reviewed By: _____
Signature Date Signature Date

Responsibility of:
Lab supervisor or someone familiar with technique
Signature _____ Date _____

Lab Director
Signature _____ Date _____

SUMMARY:

This GLP-SOP describes the use of the TEKMAR A-10 ANALYTICAL MILL for grinding PLGA. The dry ice/alcohol cooling system required for grinding the PLGA is described. Operation of the mill is taken from Tekmar product literature.

KEY WORDS: Tekmar A-10, Grinding, Mill

EQUIPMENT:

- Tekmar A-10 Analytical Mill, [Tekmar-Dohrmann, Inc. Tel: (513) 247-7000/7047; Fax: (513) 247-7050]
- Centrifugal Pump, Model LC 2CP MD (115 volt, 0.92/1.1 amp, 60/50 Hz), March Mfg., Inc., Glenview, IL,
- Nalgene 5 gallon cylindrical tank with spigot and cover (54102-0005)
- Nalgene 2 liter beaker
- Approximately 15 feet of copper tubing, 0.375 inch diameter, fashioned into a coil of approximately six loops, 8" diameter
- Large pipette for priming centrifugal pump
- Tygon tubing, hose clamps for connections
- Ethylene glycol/(anti freeze/water) and dry ice
- Digital thermometer and thermocouple or low temperature thermometer

THE COOLING SYSTEM:

- Put about 1.5 gallons of the cooling fluid in the 5 gallon tank.
- Put about 1.5 liters of IPA into the 2 liter beaker.
- Prime the pump with IPA using the "large pipette", making sure that all tubing is filled.
- Connect the centrifugal pump as shown in the diagram. Make sure that the free ends of the inlet tube to the pump and the outlet tube from the Tekmar are both in the 2-liter beaker.
- Add dry ice carefully to the tank. Do NOT put dry ice into the 2 liter beaker.
- When cool, plug pump into 115 V power source.

GRINDING PROCEDURE:

See accompanying instructions.

Cambridge Scientific, Inc.
180 Fawcett Street
Cambridge, MA 02138

TEKMAR GRINDING PROCEDURE

Always Wear A Dust Mask And Latex Gloves When Grinding Polymer

1. Make sure the grinding and cooling system apparatus is set up as shown in Figure 1. Note: Diagram shows the arrangement for simultaneous cooling of two mills. Of course, one mill may be eliminated if only one is required.
2. Using the insulated gloves, place several pieces of dry ice into the ethylene glycol/water in the bucket. This serves as a coolant to lower the temperature of the ethylene glycol through the system.
3. Place a thermocouple inside the bucket to monitor the temperature of the ethylene glycol flowing through the system.
4. Grinding may only commence after the ethylene glycol temperature has fallen to about -20°C .
5. Place the dry polymer pieces into grinder reservoir; be sure that the proper blades and cover are used. Turn on grinder for 30-60 seconds.
6. Turn off grinder and open only when blades have stopped spinning completely. The particles remaining on the inside of the cover may be brushed off into a sieve or back into the grinder.
7. After allowing about 30-60 seconds before restarting the grinder, repeat the grinding steps until the polymer sample is sufficiently small. More material may be added as ground polymer is brushed out.
8. When grinding is complete, place fine polymer powder in a sieve of desired particle size with a bottom and cover. See SOP EQP 5-1 for sieving procedure.

Figure 1: Dual Tekmar Cooling System

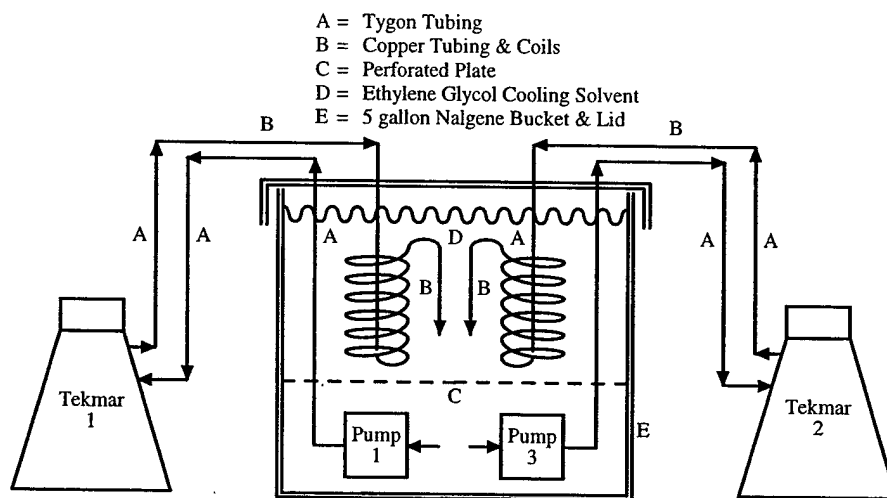

CSI GLP SOP
No. EQP 11-1

CAMBRIDGE SCIENTIFIC, INC.
Good Laboratory Practice Standard Operating Procedure

Date: 9 September 2002

OPERATION OF TEKMAR ANALYTICAL MILL WITH USA STANDARD SIEVE SERIES

Written By: _____ Reviewed By: _____
Signature Date Signature Date

Responsibility of:
Lab supervisor or someone
familiar with technique

Signature Date

Lab Director

Signature Date

SUMMARY:

This GLP-SOP describes the use of the TEKMAR ANALYTICAL MILL and STANDARD MESH SCREENS

KEY WORDS: Sieving, sieve shaker, sieves, screens

EQUIPMENT:

- Tekmar A-10 Analytical Mill, [Tekmar-Dohrmann, Inc. Tel: (513) 247-7000/7047; Fax: (513) 247-7050]
- 43- μ m, stainless steel mesh, #325, Cambridge Wire Cloth, Cambridge, MD
- Edwards Vacuum Pump, E2M-1, Crawley Sussex, England

OPERATION:

See accompanying Operating Instructions for the Tekmar Mill.
Specific for isolation of PLGA microparticles less than 43- μ m during the grinding procedure.

OPERATING INSTRUCTIONS TEKMAR MILL WITH STANDARD MESH SIEVES

I. INTRODUCTION

The Tekmar Mill is used with standard ASTM E-11 sieves to separate materials according to particle size. A wide variety of materials can be sieved into as many as even particle size ranges. The addition of the sieves in line with the Tekmar Mill is recommended for sieving heavy minerals, light organic samples, fine pharmaceutical powders, etc. The particles may be isolated during the grinding procedure.

2. DESCRIPTION

The lid from the Tekmar Mill is replaced by a 2-inch poly(vinyl chloride) (PVC) pipe fitting and cap. A stainless steel mesh is inserted into the pipe fitting and secured with the use of an o-ring. A 1/2-inch hole is bore into the PVC cap and fitted with a male polypropylene pipe fitting. Polypropylene tubing is connected from the PVC cap to the vacuum pump. The tubing is covered with 0.22- μm Teflon filter paper on which particles will be collected during the grinding and sieving procedure.

3. OPERATION

The operation of the Tekmar Mill/Sieve consists of the following steps:

- Attach the modified cap and sieve unit to the Tekmar Mill and lock into place using washers.
- Operate the mill per standard procedures.
- Turn the vacuum pump on to sieve the particles and collect on the filter paper.
- After the grinding process has been completed, collect sieved particles and mass.
- Collect unsieved, large particle aggregates remaining in the grinding chamber and mass.

4. MAINTENANCE

Clean sieve and Tekmar Mill between each use per standard procedures.

CSI GLP SOP
No. EQP 6-1

CAMBRIDGE SCIENTIFIC, INC.
Good Laboratory Practice Standard Operating Procedure

Date: 22 April 1998

OPERATION OF POLYSCIENCE MICROPROCESSOR CONTROLLED SHAKER WATER BATHS

Written By: _____ Reviewed By: _____
Signature Date Signature Date

Responsibility of:
Lab supervisor or someone
familiar with technique

Signature Date

Lab Director

Signature Date

SUMMARY:

This GLP-SOP describes the operation and maintenance of the thermostatically controlled shaker water bath (PolyScience Model No. SH 28L, Cat. No, 040674).

KEY WORDS: water bath

EQUIPMENT:

Polyscience microprocessor controlled water bath (Model No. SH 28L, Cat. No, 040674)

Cambridge Scientific, Inc.
180 Fawcett Street
Cambridge, MA 02138

▽ POLYSCIENCE

Microprocessor Controlled Water Baths

PolyScience Water Baths offer the versatility needed to handle virtually any clinical laboratory procedure—incubation, inactivation, agglutination—as well as most pharmaceutical, serological, biomedical and industrial procedures.

Available in 2, 5, 10, 20, 28 liter and 5/10L Dual Chamber capacities, and 120 or 240 volt power requirements. The baths operate with water or oil as the bath medium. All models offer temperature range of ambient to 100°C, or to 60°C without cover.

Baths utilize an energy efficient, large-area heater and thermostatic control to provide $\pm 1^\circ\text{C}$ temperature uniformity and $\pm .25$ stability over the unit's entire operating range.¹

All have sensitive PID microprocessor control (Proportional Integral Derivative.) This provides proportional heater control which anticipates the approach to your selected temperature setpoint and prevents overshoots.

A redundant thermostat is standard on all models. The microprocessor-based primary thermostat eliminates temperature drifting. The secondary SAFETY SET thermostat prevents thermal runaway. And, although not designed for use as a dry bath, operation of the bath without liquid will not damage bath or heaters.

Corrosive-resistant and easy to maintain, the Water Bath tank is fabricated from a single stainless steel sheet—deep drawn to provide a tank free of welds and seams that leak. Tank corners are rounded for easy, thorough cleaning.

The entire unit is housed in a tough-well-insulated stainless steel casing that is corrosion and chemical resistant. As an added convenience a drain pump is supplied with all large volume models.

For setpoint security, the TEMPERATURE SET knob is activated only after pressing the SET/MENU button. Temperature setting can only be changed while the °C or °F indicators are flashing. A few seconds of keypad inactivity returns the unit to normal operating mode so that setpoint cannot be accidentally altered during extended or unattended operation.

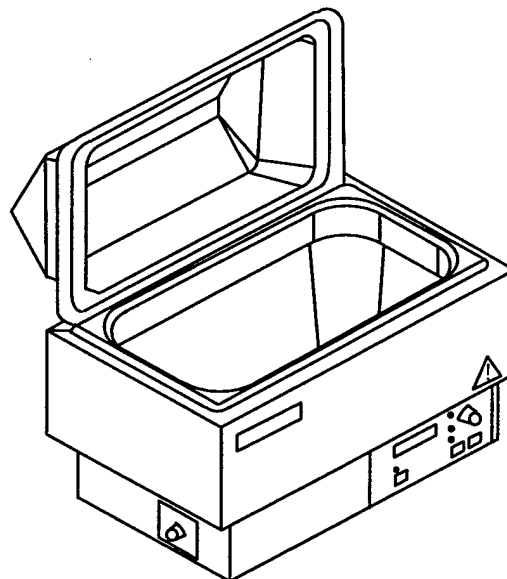

120-Volt Models:

- Model 2L Catalog No. 040650
- Model 2LS Catalog No. 040654
- Model 5L Catalog No. 040658
- Model 10L Catalog No. 040662
- Model 20L Catalog No. 040670
- Model 28L Catalog No. 040674
- Dual Chamber 5/10L Catalog No. 046659

240-Volt Models:

- Model 2L Catalog No. 040652
- Model 2LS Catalog No. 040656
- Model 5L Catalog No. 040660
- Model 10L Catalog No. 040664
- Model 20L Catalog No. 040672
- Model 28L Catalog No. 040676
- Dual Chamber 5/10L Catalog No. 046661

UNPACKING

The PolyScience Microprocessor Controlled Water Bath is shipped in a single carton. When unpacking the appliance, check each "loose" item against the packing list below. If items are missing, notify your PolyScience branch or representative, identifying the part by name. NOTE: If shipping damage is observed, keep the entire shipment intact—retaining the carton and all packing material—and file claim with the final carrier. Usually the firm will send an investigator to ascertain liability.

¹ Refer to Suitable Fluids for detailed information on fluids and temperature stability

Cambridge Scientific, Inc.
180 Fawcett Street
Cambridge, MA 02138

PACKING LIST

Qty	Item
1	PolyScience Water Bath
1	Lid Assembly
1	Sample Tray
1	Instructions
1	Warranty Card
1	Thermometer Clip
1	Siphon Pump ²

ASSEMBLY

The PolyScience Microprocessor Controlled Water Bath comes fully assembled for your convenience.

For applications above 60°C, the cover is required. Insert the lid's hinge into the bracket on the bath casing. Properly installed, the lid tilts up to a 90°C position. Condensation drains back into the bath.

If a thermometer is used, bend the supplied thermometer clip to securely hold onto your thermometer. Hang clip on the center front edge of the bath. Line clip up to the lid's front notch.

OPERATION

Set the PolyScience Microprocessor Controlled Water Bath on a table or bench that is level and in an area that is free from drafts and wide ambient temperature variations, such as near heater or air conditioning vents.

All bath models are operated as follows:

1. Check data plate attached to rear of unit for power requirements. Connect line cord plug to a suitable grounded electrical outlet.
2. Fill bath with fluid so that liquid level is approximately 1-inch from top when samples are placed in bath. Note: See **SUITABLE FLUIDS** For more information on bath fluid selection.
3. Power switch on the rear panel is to the ON position. Press the ON button on the front panel, the LED display illuminates. The display indicates the set temperature for a few seconds, then displays the actual bath temperature. If the display does not light, check circuit breaker on the rear panel and check power source.

NOTE: The 120-volt models have a circuit breaker button that protrudes approx. 3/16", when tripped it extends to 5/16", 240-volt models are equipped with a rocker type circuit breaker.

4. Before Setting Temperature, Turn the SAFETY SET to the full clockwise position, dial position 10. (on 240V models the SAFETY SET may be recessed, remove the clear plastic cap to the control, then use a standard screwdriver to rotate.)
5. To Convert the Readout to Display in °F or °C press and hold the SET/MENU button until the display reads "UNIT". Press SET/MENU again then turn the TEMPERATURE SET knob to select °C or °F. This setting is accepted after a few seconds or press SET/MENU to go back to the "UNIT" display.
6. To Enter Maximum Allowable Setpoint (high limit)
Press and hold the SET/MENU button until the display reads "UNIT". Turn the TEMPERATURE SET knob until the display reads "HI-L" (high limit), press the SET/MENU button and enter the desired value using the TEMPERATURE SET knob. The setting will be accepted after a few seconds or press the SET/MENU to go back to the "UNIT" display. Your set temperature cannot be set greater than "HI-L" high limit.
7. To SET the TEMPERATURE SET
When initially turning on the unit, the °C or °F indicators will flash to show temperature can be set. Turn the TEMPERATURE SET knob to your desired setting. Setting is accepted after pressing the SET/MENU button (or after a few seconds of keypad inactivity.) The °C or °F indicators stop flashing and the LED display will show the actual bath temperature.
The set temperature may be changed or checked at anytime during an operation by pressing the SET/MENU button. The °C or °F flashing indicates the unit is in temperature set mode. *NOTE: To attain temperatures above 60°C, the bath cover must be used.*
When bath temperature has stabilized at the desired temperature, the HEAT indicator will cycle on and off as the thermostat

² 10, 20, 28 Liter and Dual Chamber Models Only.

calls for heat to maintain the set temperature.

8. To Set the Safety SET

Once the bath has stabilized at the desired temperature, turn the SAFETY SET counterclockwise until the WARNING indicator comes on. Now turn clockwise to adjust the SAFETY SET temperature slightly higher, until indicator goes off. Be sure the SAFETY SET temperature is sufficiently higher than the set temperature.

Adjusting the SAFETY SET thermostat sets the backup safety circuit to assume control of the bath if the TEMPERATURE SET has malfunctioned, indicated by the WARNING indicator.

OPERATION NOTES

- To return all settings to the factory default values, switch the rear panel power switch off, then press and hold the SET/MENU button while rear panel power is switched to the ON position.
- For optimum results, maintain fluid level throughout the operating period, adding fluid as needed. Attempt to refill fluid at same temperature as bath.
- The use of the bath lid and hollow plastic floating balls will help prevent heat and vapor loss.
- Select a fluid that is not corrosive and non flammable. See SUITABLE FLUIDS for detailed information.
- This unit is designed for indoor use only with an allowable ambient temperature between +4°C to 35°C, and relative humidity not greater than 75%. The temperature controller is capable of operation from 0°C to +100°C fluid temperature.
- The **Dual Chamber Model** contains two reservoir tanks, 5-liter and 10-liter, with independent microprocessor controllers. These controllers can be set to run two separate operations simultaneously.

CONTROL PANEL POSITION FOR THE 20 AND 28 LITER

These models have a control panel that can be positioned on the front or the side of the unit to achieve best use of bench space. To change the position of the controller:

1. Disconnect unit from power source.
2. Remove the two screws from the front control panel.
Carefully remove the control panel from the front mount, disconnect the controller's ribbon cable.
3. Remove the two screws and cover plate on the side of the unit. Reconnect the controller's ribbon cable into the side mount and fit the control panel (the ribbon cable is keyed—take care in reconnecting.) Replace the screws in the control panel.
4. Replace the cover plate and screws in the front panel.
5. Reconnect unit to power source.

CLEANING

Thoroughly clean the bath before each use. Use only mild soap and water when cleaning. Do not use steel wool as damage to the unit may result. Non steel scouring pads are acceptable.

SERVICE

PolyScience Water Baths are constructed to simplify service and replacement procedures. (For example: push-on terminals are used throughout to eliminate the need for soldering.) Once the bottom plate is removed, there is easy access to all components. See DISASSEMBLING THE BATH.

DISASSEMBLING THE BATH

The following procedure should only be done by a qualified service technician.

To disassemble the Water Bath:

1. Disconnect the bath from its power source.
2. Drain the bath of all fluid.
3. Remove the cover, thermometer, clip and ampoule tray.
4. Turn the bath upside down to expose the bottom.
5. Remove the screws around the outer edge of the tank casing that secure the top to the base of the bath.
6. At this point, all the internal components are accessible for replacement.

SUITABLE FLUIDS

Cambridge Scientific, Inc.
180 Fawcett Street
Cambridge, MA 02138

A variety of fluids can be used with the bath depending on the operators application. See CHART OF SPECIFIC FLUIDS.

The fluid must be compatible with 300 series stainless steel. Generally, any single type of fluid will be able to stabilize to $\pm 1^{\circ}\text{C}$ over the fluid's normal range. Use fluids that will satisfy safety, health and compatibility requirements.

Use the chart in selecting fluid for your application, it is highly recommended to stay within the fluid's normal range for best temperature stability and low vaporization. Extreme range operation should be avoided. The centistoke(cs) ratings are at 25°C .

The following fluids are *not recommended* and may cause damage to the unit:

- Any flammable fluids
- Deionized water
- Chlorides or bleach
- Automotive antifreeze with additive
- Most photographic solutions
- Strong concentrations of any acid or bases
- Mid concentrations of any acid with the following elements (or Halides) in their formulas: Chlorine (Cl), Fluorine (F), Sulfur (S), Sodium Chloride, Calcium Chloride, Chromate, Chromium salts.

NOTE: Fumes from acidic solutions may cause corrosion of the stainless steel reservoir. Care should be taken to maintain a neutral pH at all times.

Warning: Do not operate unit with any potentially flammable materials in the reservoir as a fire hazard may result.

APPLICATION NOTES

At fluid's high temperature extreme:

- Heat loss from vapor will cause poor temperature stability
- A fume hood may be required to prevent the buildup of vapors inside the room.
- The use of a cover and floating hollow balls will help prevent heat and vapor loss.
- Fluid lost from vapor will have to be frequently replenished.
- If using water, a few drops of PolyScience Lab Algaecide reduces algae formation.

CONTROLS AND INDICATORS

PolyScience Microprocessor Controlled Water Bath models have two thermostat controls (on 240 volt models, the SAFETY SET may be recessed and accessible with a screw driver) and two indicator lights.

Functionally, these components constitute two control circuits which operate independently of each other.

The primary control system uses the front panel TEMPERATURE SET knob to set desired temperature. The HEATING indicator illuminates when bath is heating.

Note: When bath temperature approaches your set temperature, the HEATING indicator flashes. This is the PID proportional heater control anticipating approach to your set temperature and preventing overshoot. The second system uses the SAFETY set (on side or rear panel of unit) to select bath temperature at a slightly higher setting over your desired set temperature.

This dual system protects samples from damage due to over heating. In operation if the bath temperature reaches the

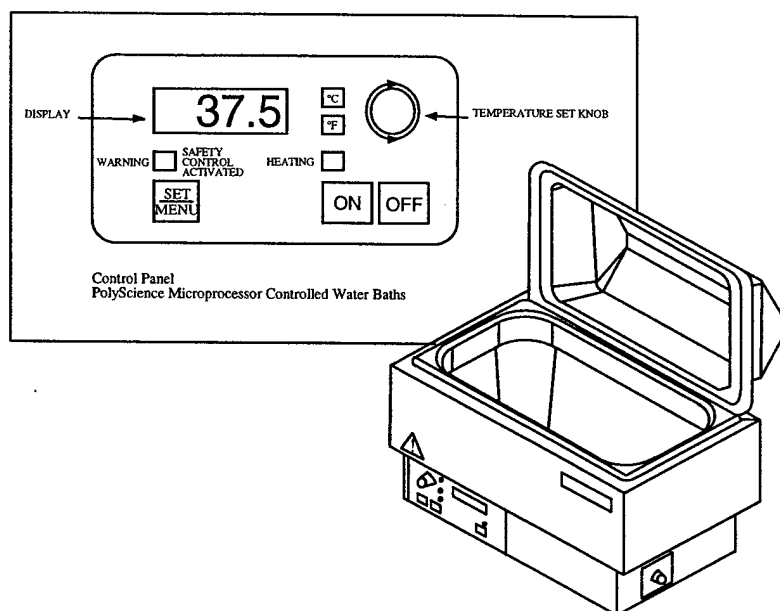

SAFETY SET temperature, the WARNING indicator illuminates to show the safety control system has been activated.

CHART OF SPECIFIC FLUIDS

Fluid Description	Specific Heat @25°C	Normal Range	Extreme Range
Water	1.00	10°C > 90°C	2°C > 100°C
Glycol or Glycerin 30%/Water 70%	.90	0°C > 95°C	-15°C > 107°C
Glycol or Glycerin 50%/Water 50%	.82	-25°C > 100°C	-35°C > 115°C
Glycol or Glycerin 100%	.62	50°C > 125°C	25°C > 155°C*
Mineral Oil	.40	50°C > 150°C	25°C > 190°C
Syltherm®XLT, 1.9 cs Silicone Oil	.30	-50°C > 45°C	-73°C > 45°C
DC200, 5 cs Silicone Oil	.32	-35°C > 65°C	-50°C > 125°C
DC200, 10 cs Silicone Oil	.34	-20°C > 80°C	-35°C > 165°C
DC200, 20 cs Silicone Oil	.36	0°C > 100°C	-10°C > 230°C
DC200, 450 cs Silicone Oil	.39	50°C > 150°C	5°C > 270°C
DC510, 50 cs Silicone Oil	.39	50°C > 150°C	5°C > 270°C
DC550, 125 cs Silicone Oil	.42	100°C > 200°C	80°C > 232°C

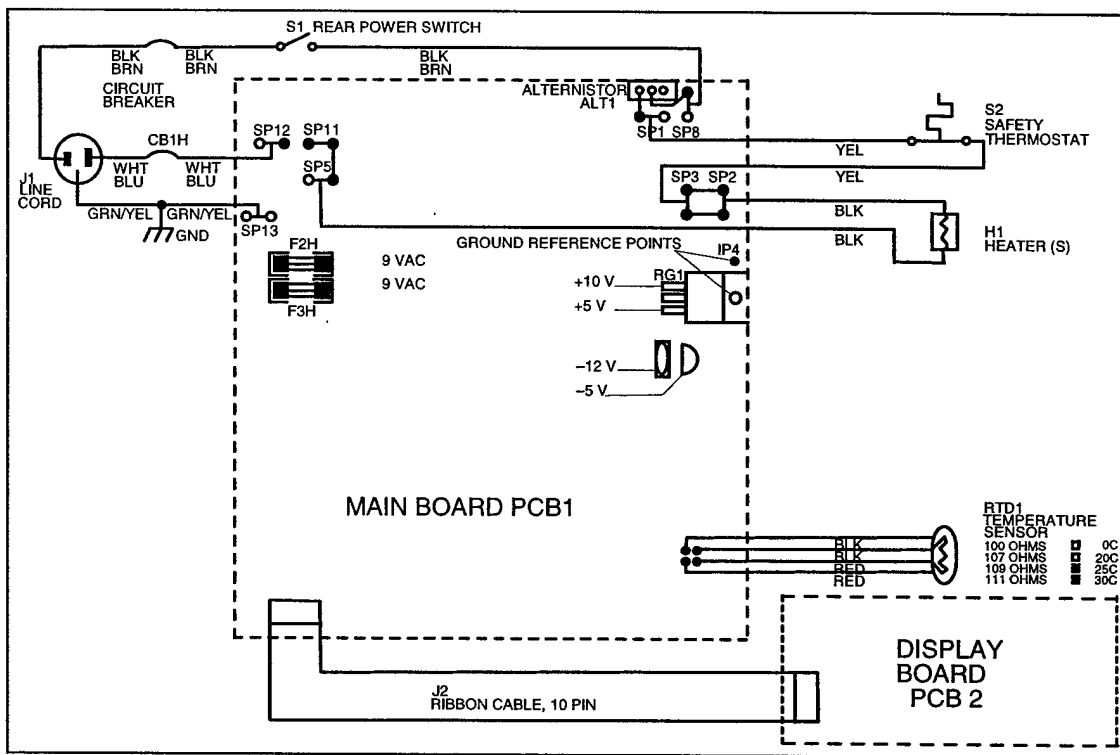

- *Items with an asterisk vary with line voltage and model size
- *Power line cords vary with voltage and plug configuration
- *Double pole breaker used in 240V models only
- *F2, F3. Fuses are used only in 240V models. Other units use jumpers.
- *S1 Switch used only in 120V models

Wht and Blk power leads are substituted for Blu and Brn in 240V units.

Thermally conductive tape is used to mount S2 and RTD1 sensors to tank. Then both sensors are covered with Fiberglas.

Cambridge Scientific, Inc.
 180 Fawcett Street
 Cambridge, MA 02138

CSI GLP SOP
No. EQP 7-1

CAMBRIDGE SCIENTIFIC, INC.
Good Laboratory Practice Standard Operating Procedure

Date: 28 April 1998

OPERATION OF SYNTRON ELECTRIC VIBRATOR WITH USA STANDARD SIEVE

Written By: _____ Reviewed By: _____
Signature Date Signature Date

Responsibility of:
Lab supervisor or someone
familiar with technique

Signature Date

Lab Director

Signature Date

SUMMARY:

This GLP-SOP describes the use of the SYNTRON ELECTRIC VIBRATOR and USA STANDARD SIEVE SERIES with reference to SOP EQP 5-1 for use of sieves

KEY WORDS: Sieving, sieve shaker, sieves, screens

EQUIPMENT:

Syntron Electric Vibrator and USA Standard Sieve Series (see CSI SOP EQP 5-1)

REFERENCE:

CSI SOP EQP 5-1 (Operation of CSC Sieve Shaker with USA Standard Sieve Series)

Cambridge Scientific, Inc.
180 Fawcett Street
Cambridge, MA 02138

OPERATION OF SYNTRON ELECTRIC VIBRATOR**SYNTRON ELECTRIC VIBRATOR
SYNTRON COMPANY, HOMER CITY, PA**

Type: TSS15
Style: 1952
Manual: Not available

Schematic of the Equipment: (see next page)

PROCEDURE:

1. The sieves are placed with a receiver sieve on the bottom in the center of the platform. The appropriate sieves are placed in an increasing mesh size order.
2. The metal cover is then raised between the attached two screws.
3. A Styrofoam plate is then placed on the sieves between the attached metal plate.
4. Tighten the two screws down on the sieves evenly.
5. Turn on the power switch for ten minutes.
6. Turn off the power and untighten the two screws.
7. Remove the sieve and recover the particles in the desired size range.

MAINTENANCE:

Routine Maintenance: None
Non-Routine Maintenance: None

CSI GLP SOP
No. EQP 8-1

CAMBRIDGE SCIENTIFIC, INC.
Good Laboratory Practice Standard Operating Procedure

Date: To be completed, 1998

PROCEDURE FOR CLEANING SIEVES

Written By: _____ Reviewed By: _____
Signature Date Signature Date

Responsibility of:
Lab supervisor or someone
familiar with technique

Signature Date

Lab Director

Signature Date

SUMMARY:
This GLP SOP describes the procedure to be used for cleaning: sieves.

KEY WORDS: sieves, cleaning

EQUIPMENT:
Sieves, pans, covers, acetone wash bottle

- PROCEDURE:**
1. Sieves, collecting pan and cover shall first be rinsed with water in a lab sink using a strong jet or flow of water to dislodge insoluble particles from the screens.
 2. Rinse all parts with acetone from a wash bottle. The acetone wash is especially important to dissolve water insoluble particles trapped in the mesh. It also facilitates rapid drying.
 3. Allow all parts to air dry.
 4. After drying visually inspect each item, especially the sieves for particles trapped in the mesh.
 5. If particles are trapped, repeat steps 1-4 or just 2-4.
 6. Store sieves in a polyethylene bag.

**CSI GLP SOP
No. EQP 9-1**

**CAMBRIDGE SCIENTIFIC, INC.
Good Laboratory Practice Standard Operating Procedure**

Date: 6 May 1998

PROCEDURE FOR CLEANING MOLD, RAM, DIE ASSEMBLY BY SONICATION

Written By: _____ Reviewed By: _____
Signature Date Signature Date

Responsibility of:
Lab supervisor or someone
familiar with technique

Signature Date

Lab Director

Signature Date

SUMMARY:

This GLP-SOP describes the procedure to be used for cleaning by sonification.

KEY WORDS: cleaning, sonification

EQUIPMENT:

mold, ram, die assembly

PROCEDURE:

1. Place Fisher FS 30 Ultrasonic Cleaner (USC) in a working hood.
2. After extrusion, allow the mold, ram, die assembly (MRDA) to cool and then disassemble, do not force them.
3. Place all parts (including bolts) into the USC.
4. Fill USC with methylene chloride until all parts are covered. Cover USC with its lid.
5. Sonicate for 10 minutes at room temperature.
6. Remove parts with metal tongs (or use silver shield (4 mil) gloves (Fisher 11-393-65).
7. If necessary, disassemble parts that had been stuck together and repeat steps 5 and 6.
8. Allow to air dry and then visually inspect for cleanliness.
9. Rinse parts with acetone from a wash bottle and allow to dry.
10. Wrap each part in absorbent paper and store the entire MRDA in a plastic bag (screws may be wrapped together.)

CSI GLP SOP
No. EQP 10-1

CAMBRIDGE SCIENTIFIC, INC.
Good Laboratory Practice Standard Operating Procedure

Date: 6 May 1998

OPERATION OF FS-30 ULTRASONIC CLEANER
FOR REMOVAL OF POLYMER FROM MOLD ASSEMBLY

Written By: _____ Reviewed By: _____
Signature Date Signature Date

Responsibility of:
Lab supervisor or someone
familiar with technique

Signature Date

Lab Director

Signature Date

SUMMARY:

This GLP-SOP describes the procedure to be used in the operation of an FS-30 ultrasonic cleaner for removal of polymer from a mold assembly by sonification.

KEY WORDS: sonification, polymer removal

EQUIPMENT:

Ultrasonic Cleaner (USC), Fisher Cat. No. 15-335-32
Capacity: 3 qts (2.8 liter)
Tank: 4" x 9 1/2" x 5 1/2" (10.2 x 24.1 x 14.0 cm)
Power: 120 v, 50/60 Hz, 1.3 amp, 160 watt
Output frequency: 44-48 kHz.

PROCEDURE:

1. Place USC in hood and plug into appropriate power source (120 V).
2. Before turning on, place parts in the tank and pour in sufficient methylene chloride (MC) to cover parts. When using MC, operate at room temperature.
3. Cover with lid.
4. Set power dial (the time) to ten minutes.
5. Remove parts with tongs and wear MC resistant gloves (see SOP Eqp. 9-1).
6. Assembly should come apart easily; if not, repeat for another ten minutes.
7. Complete washing with an acetone rinse, followed by a water rinse, and a final acetone rinse.

THIS PAGE LEFT INTENTIONALLY BLANK

APPENDIX H

CAMBRIDGE SCIENTIFIC, INC. GOOD LABORATORY PRACTICES MATERIAL STANDARD OPERATING PROCEDURES

MATERIALS CONTROL: SOURCE AND PROPERTIES OF PLASMID DNA

SOLVENTS: ACQUISTION, CHARACTERIZATION, VALIDIATION

**POLY (D,L-LACTIDE-CO-GLYCOLIDE): ACQUISTION, CHARACTERIZATION,
VALIDIATION**

PURIFICATION OF PLGA'S BY PRECIPITATION

**RESIDUAL ACETIC ACID IN PLGA FOAM BY pH MEASUREMENT AFTER
LYOPHILIZATION AND GRINDING TO $\leq 125 \mu\text{m}$**

CSI GLP SOP
No. MAT 10-1
(DNA-1)

CAMBRIDGE SCIENTIFIC, INC.
Good Laboratory Practice Standard Operating Procedure

Date: 11 December 2002

MATERIALS CONTROL: SOURCE AND PROPERTIES OF PLASMID DNA

Written By: _____ Reviewed By: _____
Signature Date Signature Date

Responsibility of:
Lab supervisor or someone
familiar with technique

Signature Date

Lab Director

Signature Date

SUMMARY:

This GLP SOP describes QA/QC protocols for characterization, validation, and acceptance of plasmid DNA with emphasis on sources and properties.

KEY WORDS: plasmid DNA, pDNA, sources, and properties

Manufacturers of Plasmid DNA Suitable for Preclinical Vaccine Testing

Puresyn, Inc.
87 Great Valley Parkway
Malvern, PA 19355
Tel: (610) 640-0800
Fax: (610) 640-0808
purification@puresyn.com

Vical, Inc.
9373 Towne Center Drive
Suite 100
San Diego, CA 92121
Tel: (858) 646-1144
Fax: (858) 646-1150

Althea Technologies, Inc.
3550 General Atomics Court
Building #2
San Diego, CA 92121
Tel: (858) 455-2183
Fax: (858) 455-2188
info@altheatech.com

Physical Properties of Plasmid Malaria Vaccine

A plasmid malaria vaccine (VR2578) was manufactured by Puresyn, Inc. for Cambridge Scientific, Inc. Plasmid samples are evaluated for purity, size, and percent supercoiling.

Lot #C25OCT02A

Cambridge Scientific, Inc.
180 Fawcett Street
Cambridge, MA 02138

Sample #QC-2381

Test (Puresyn SOP#)	Specifications	Results
Amount (A007)	50 mg	50.0 mg
A260/280 (A007)	1.7-2.0	1.9
Concentration (A007)	>1.0 mg/mL	1.77 mg/mL
DNA homogeneity (A006)	>90% All Supercoiled Forms	93.9%
RNA (A006)	None Detected*	ND
Linear Plasmid (A022)	None Detected*	ND
Chromosomal DNA (A022)	None Detected*	ND
Protein (A021)	For Information Only	0.05%
Endotoxin (A008)	<30 EU/mg	<7.4 EU/mg
Identity (A011)	Consistent with map	Consistent
Appearance (A020)	Clear, Colorless	Clear, colorless
Formulation	0.9% Saline	0.9% Saline

*When loading 1 µg of plasmid on a gel.

CSI GLP SOP
No. MAT 4-2
(Solvents-2)

CAMBRIDGE SCIENTIFIC, INC.
Good Laboratory Practice Standard Operating Procedure

Date: 9 September 2002

SOLVENTS: ACQUISITION, CHARACTERIZATION, VALIDATION

Written By: _____ Reviewed By: _____
Signature Date Signature Date

Responsibility of:
Lab supervisor or someone
familiar with technique

Signature Date

Lab Director

Signature Date

SUMMARY:

This GLP-SOP describes QA/QC criteria for procurement, validation, and acceptance of solvents. Solvents included in this protocol are 2-propanol (isopropanol, isopropyl alcohol or IPA), acetone, and glacial acetic acid (glHAc). The purpose is to confirm identity and purity of these materials by at least one of the methods included herein.

KEY WORDS: Solvents, Isopropyl alcohol, Acetone, Glacial acetic acid

ISOPROPYL ALCOHOL

Vendor's Information (The grades indicated below should be used for polymer precipitation. For cooling the Tekmar, any grade may be used. Tekmar any grade may be used)

Aldrich	32408-6	PRA	99.9
	15497-0	Spec ACS	≥ 99.5
	43752-2	ACS Reagent	≥ 99.5
Fisher	A464-4	Optima	≥ 99.9
	(refractive index at 25°C = 1.3740 – 1.3760)		
	A451	HPLC/ACS	≥ 99.9
(refractive index at 25° = 1.3740 – 1.3760)			
Spectrum	11057	U.S.P./NF	> 99.5

Properties:

specific gravity (m): 0.78505(20/4); 0.78084(25/4); 0.728(83/4)
refractive index (m): 1.3852(8/D); 1.3802(15/D); 1.37723(20/D); 1.3749(25/D)
boiling point (m): 82.5°C
freezing/melting point (m): –89.5 to –88.5°C

Cambridge Scientific, Inc.
180 Fawcett Street
Cambridge, MA 02138

ACETONE**Vendor's Information**

Aldrich	27072-5	HPLC	≥ 99.9
	43912-6	HPLC	≥ 99.9
	41468-9	Cap. GC	≥ 99.9
			(BP 56, FP -17, RI 1.3590(20/D); Den. 0.791)
Fisher	A-11	NF/FCC	≥ 99.5
	A-921	Optima	≥ 99.6
Spectrum	AC115	U.S.P./NF	> 99.0

Properties:

specific gravity: 0.788(25/25)(m); 0.7899(hcp)
refractive index: 1.3591(20/D)(m); 1.3588(20/D)(hcp)
boiling point (m): 56.5 °C
melting point (m): -94

GLACIAL ACETIC ACID**Vendor's Information**

Aldrich	38012	double distilled	
	33882-6	99.99	
	24285-3	≥ 99.7	
Fisher	A-38	Cert ACS Plus	≥99.7 (MP 16.6-16.7°C; BP 118°C, Dens. 1.05 (25°C))
	A-490-212	USP/FCC	99.5-100.5 (MP 16.6-16.7°C; BP 118, Dens. 1.05 (25°C))
Spectrum	AC110	USP/NF	99.5-100.5

Properties:

density: 1.053 (16.67); 1.049(25/25)
refractive index: 1.3718(20/D)
boiling point: 118°C
melting point: 16.7°C
(m = Merck Index, 11th ed.; hcp = *CRC Handbook of Chem. and Physics*, 54 ed.)

APPARATUS

- Specific gravity bottles
 - Gay-Lussac (10, 25, 50, 100 ml) Fisher 03-240
 - Moore-Van Slyke (2 ml) Fisher 03-249
 - Pycnometer (10, 25, 50 ml) Fisher 03-230

Note: USP XXIII/NFXVIII specifies the use of pycnometers

- Boiling point apparatus and thermometers
 - Boiling point (elevation) apparatus Fisher 12-900
 - Ertco Beckman Differential Thermometers (ASTM 115C) (Fisher 15-060/061) Note that 15-060 has a maximum temperature of 120°C but Ertco ASTM sets of precision calibrated thermometers can be used with the apparatus. This was verified by telecon with EverReady Thermometer Co., (201) 812-7474. Also note that Test <651>, congealing temperature, identifies as suitable a thermometer with a range of <30°C in 0.1°C divisions, in the ASTM E1 series 89°C-96°C (see <21>)
- Freezing Point Depression Apparatus (Fisher 12-900)
- Melting Point Apparatus (see Fisher catalog for models)
 - Fisher-Johns
 - Electrothermal Digital
 - Mettler Toledo Digital

5. Refractometers

Abbe (Fisher 13-964)	Range 1.3–1.7, accuracy ± 0.0001
Low price (Fisher 13-947)	Range 1.3–1.9, accuracy ± 0.002
Digital Abbe Mark II with Automatic temperature compensation (Fisher 13-9750)	Range 1.320–1.700, accuracy ± 0.0001

The following monographs are taken from
 The United States Pharmacopeia USP XXII
 The National Formulary NF XVII
 United States Pharmacopeial Convention, Inc.
 Rockville, MD
 Published 1990

USP XXII NF XVII Official Monographs

ACETONE

C₃H₆O 58.08

2- Propanone.

Acetone [67-4-1]

CH₃COCH₃

AA Acetone contains not less than 99.0 percent of C₃H₆O, calculated on the anhydrous basis.

Caution—Acetone is very flammable.
 Do not use where it may be ignited.

Packaging and storage—Preserve in tight containers, remote from fire.

Identification—Using 0.1-mm cells, obtain the infrared absorption spectrum of a 1 in 10 solution of it in carbon tetrachloride, with carbon tetrachloride in the reference beam. It exhibits a strong band at about 5.8 μm ; a strong region of absorption between 6.8 μm and 7.5 μm , with maxima at about 7.0 μm and 7.3 μm ; a strong maximum at about 8.2 μm ; and weak maxima at about 9.2 μm and 11.0 μm .

Specific gravity <841>: not more than 0.789.

Water—

Standard preparation—Transfer 0.50 mL of water to a dry 100-mL volumetric flask, dilute with dehydrated isopropyl alcohol to volume, and mix.

Chromatographic system—Under typical conditions, the gas chromatograph is equipped with a thermal conductivity detector, and contains a 1.5-m \times 6-mm stainless steel column containing packing S4. The column is maintained at a temperature of 180°, and helium is used as the carrier gas.

Procedure—Inject 5.0 μL of *Standard preparation* into a suitable gas chromatograph and determine the area under the water peak. Similarly inject 5.0 μL of the same dehydrated isopropyl alcohol to provide a blank, and determine the area under the water peak. The retention time is about 1 minute; Similarly inject 5.0 μL of Acetone. The area under the water peak for Acetone is not greater than that from the *Standard preparation* corrected for the area under the water peak in the blank chromatogram (0.5%).

Nonvolatile residue—Evaporate 50 mL in a tarred porcelain dish on a steam bath, and dry at 105° for 1 hour: the weight of the residue does not exceed 2 mg (0.004%).

Readily oxidizable substances—Mix 20 mL with 0.10 mL of 0.10 N potassium permanganate in a glass-stoppered bottle: the permanganate color of the mixture does not completely disappear within 15 minutes.

Cambridge Scientific, Inc.
 180 Fawcett Street
 Cambridge, MA 02138

Assay—

Chromatographic system—Under typical conditions, the instrument is equipped with a flame-ionization detector, and contains a 1.8-m × 3-mm column containing packing S4. The column temperature is programmed at a rate of about 8° per minute from 110° to 220°, and helium is used as the carrier gas.

Procedure—Inject a suitable volume, typically about 0.5 μL , of Acetone into a suitable gas chromatograph, and record the chromatogram. Calculate the percentage of $\text{C}_3\text{H}_6\text{O}$ in the Acetone, on the anhydrous basis, by dividing the area under the acetone peak by the sum of the areas under all of the peaks and multiplying by 100. [Note—No separate correction is applied for water content, since water does not respond to the flame-ionization detector.]

Glacial Acetic Acid

CH_3COOH
 $\text{C}_2\text{H}_4\text{O}_2$ 60.05
Acetic acid.
Acetic acid [64-19-7].

AA Glacial Acetic Acid contains not less than 99.5 percent and not more than 100.5 percent, by weight of $\text{C}_2\text{H}_4\text{O}_2$.

Packaging and storage—Preserve in tight containers.

Identification—A mixture of 1 volume of it with 2 volumes of water responds to the tests for *Acetate* <191>.

Congealing temperature—<651>: not lower than 15.6°.

Nonvolatile residue—Evaporate 20 mL in a tared dish, and dry at 105° for 1 hour; the weight of the residue does not exceed 1.0 mg.

Chloride—Dilute 1.0 mL with 20 mL of water, and add 5 drops of silver nitrate TS: no opalescence is produced.

Sulfate—Dilute 1.0 mL with 10 mL of water, and add 1 mL of barium chloride TS: no turbidity is produced.

Heavy metals <231>—To the residue obtained in the test for *Nonvolatile residue* add 8 mL of 0.1 N hydrochloric acid, warm gently until solution is complete, dilute with water to 100 mL, and use 20 mL of the solution: the limit is 5 ppm.

Readily oxidizable substances—Dilute 2.0 mL in a glass-stoppered vessel with 10 mL of water, and add 0.10 mL of 0.10 N potassium permanganate: the pink color is not changed to brown within 2 hours.

Assay—Measure about 2 mL of Glacial Acetic Acid into a glass-stoppered flask, previously tared while containing about 20 mL of water, and weigh again to obtain the weight of the substance under assay. Add 20 mL of water, then add phenolphthalein, and titrate with 1 N sodium hydroxide VS. Each mL of 1 N sodium hydroxide is equivalent to 60.05 mg of $\text{C}_2\text{H}_4\text{O}_2$.

USP XXII NFXVII Official Monographs

ISOPROPYL ALCOHOL

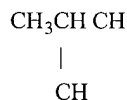

$\text{C}_3\text{H}_8\text{O}$ 60.10

2-Propanol.

Isopropyl alcohol [67-3-0].

>> Isopropyl Alcohol contains not less than 99.0 percent of $\text{C}_3\text{H}_8\text{O}$

Packaging and storage Preserve in tight containers, remote from heat.

Identification—Determine the infrared absorption spectrum, in a 0.1-mm cell, of a 1 in 20 solution of it in carbon tetrachloride, with carbon tetrachloride in the reference beam. It exhibits a region of strong absorption between 6.7 μm and 8.0 μm (the most prominent features being the peaks at about 6.8 μm , 7.2 μm , 7.4 μm , 7.7 μm , and 8.0 μm), a region of strong absorption between 8.3 μm and 9.5 μm (the most prominent features being the peaks at about 8.6 μm and 8.7 μm), and a strong peak at about 10.5 μm .

Specific gravity <841>—between 0.783 and 0.787.

Refractive index <831>—between 1.376 and 1.378 at 20°.

Acidity—To 50 mL in a suitable flask add 100 mL of carbon dioxide-free water. Add 2 drops of phenolphthalein TS, and titrate with 0.020 *N* sodium hydroxide to a pink color that persists for 30 seconds: not more than 0.70 mL of 0.020 *N* sodium hydroxide is required for neutralization.

Nonvolatile residue—Evaporate 50 mL in a tarred porcelain dish on a steam bath to dryness, and heat at 105° for 1 hour: the weight of the residue does not exceed 2.5 mg (0.005%).

Assay—Inject about 5 mL of Isopropyl Alcohol into a suitable gas chromatograph, equipped with a thermal conductivity detector. Under typical conditions, the gas chromatograph contains a 1.8-m \times 6.4-mm (OD) stainless steel column packed with 10 percent liquid phase G20 on support SIA, the column is maintained at 55°, and helium is used as the carrier gas at a flow rate of 45 mL per minute. Relative retention times of some of the possible components, when present, are: air at 0.09, diethyl ether at 0.14, disopropyl ether at 0.17, acetone at 0.37, isopropyl alcohol at 1.00, 2-butanol at 1.64, n-propyl alcohol at 1.86, and water at 3.14. Calculate the percentage of $\text{C}_3\text{H}_8\text{O}$ in the isopropyl alcohol by dividing the area under the isopropyl alcohol peak by the sum of the areas under all of the peaks observed, and multiplying by 100.

Cambridge Scientific, Inc.

180 Fawcett Street

Cambridge, MA 02138

<831> REFRACTIVE INDEX

The refractive index (n) of a substance is the ratio of the velocity of light in air to the velocity of light in the substance. It is valuable in the identification of substances and the detection of impurities.

Although the standard temperature for Pharmacopeial measurements is 25°, many of the refractive index specifications in the individual monographs call for determining this value at 20°. The temperature should be carefully adjusted and maintained, since the refractive index varies significantly with temperature.

The values for refractive index given in this Pharmacopeia are for the D line of sodium (doublet at 589.0 nm and 589.6 nm).

Most instruments available are designed for use with white light but are calibrated to give the refractive index in terms of the D line of sodium light.

The Abbe refractometer measures the range of refractive index for those Pharmacopeial materials for which such values are given. Other refractometers of equal or greater accuracy may be employed.

To achieve the theoretical accuracy of ± 0.0001 , it is necessary to calibrate the instrument against a standard provided by the manufacturer and to check frequently the temperature control and cleanliness of the instrument by determining the refractive index of distilled water, which is 1.3330 at 20° and 1.3325 at 25°.

<841> SPECIFIC GRAVITY

Unless otherwise stated in the individual monograph, the specific gravity determination is applicable only to liquids, and, unless otherwise stated, is based on the ratio of the weight of a substance in air at 25° to that of an equal volume of water at the same temperature. Where a temperature is specified in the individual monograph, the specific gravity is the ratio of the weight of the substance in air at the specified temperature to that of an equal volume of water at the same temperature. When the substance is a solid at 25°, determine the specific gravity at the temperature directed in the individual monograph, and refer to water at 25°.

Procedure—Select a scrupulously clean, dry pycnometer that previously has been calibrated by determining its weight and the weight of recently boiled water contained in it at 25°. Adjust the temperature of the substance to about 20°, and fill the pycnometer with it. Adjust the temperature of the filled pycnometer to 25°, remove any excess of the substance, and weigh. Subtract the tare weight of the pycnometer from the filled weight of the pycnometer.

The specific gravity of the substance is the quotient obtained by dividing the weight of the substance contained in the pycnometer by the weight of water contained, both determined at 25° unless otherwise directed in the individual monograph.

<651> CONGEALING TEMPERATURE

The temperature at which a substance passes from the liquid to the solid state upon cooling is a useful index to purity if heat is liberated when the solidification takes place, provided that any impurities present dissolve in the liquid only, and not in the solid. Pure substances have a well-defined freezing point, but mixtures generally freeze over a range of temperatures. For many mixtures, the congealing temperature, as determined by strict adherence to the following empirical methods, is a useful index of purity. The method for determining congealing temperatures set forth here is applicable to substances that melt between -20° and 150°, the range of the thermometer used in the bath. The congealing temperature is the maximum point (or lacking a maximum, the point of inflection) in the temperature-time curve.

Apparatus—Assemble an apparatus similar to that illustrated in which the container for the substance is a 25- × 100-mm test tube. This is provided with a suitable, short-range thermometer suspended in the center and a wire stirrer, about 30 cm long bent at its lower end into a horizontal loop around the thermometer.

The specimen container is supported, by means of a cork, in a suitable water-tight cylinder about 50 mm in internal diameter and 11 cm in length. The cylinder, in turn, is supported in a suitable bath sufficient to provide not less than a 37-mm layer surrounding the sides and bottom of the cylinder. The outside bath is provided with a suitable thermometer.

Procedure—Use a thermometer having a range not exceeding 30°, graduated in 0.1° divisions, and calibrated for, but not used at, 76-mm immersion. A suitable series of thermometer, covering a range from -20° to +150°, is available as the ASTM E-1 series 89C through 96C (see *Thermometers* <21>). Melt the substance, if a solid, at a temperature not exceeding 20° above its expected congealing point, and pour it into the test tube to a height of 50 mm to 57 mm. Assemble the apparatus with the bulb of the test tube thermometer immersed halfway between the top and bottom of the specimen in the test tube. Fill the bath to about 12 mm from the top of the tube with suitable fluid at a temperature 4° to 5° below the expected congealing point.

In case the substance is a liquid at room temperature, carry out the determination using a bath temperature about 15° below

the expected congealing point.

When the test specimen has cooled to about 5° above its expected congealing point, adjust the bath to a temperature 7° to 8° below the expected congealing point. Stir the specimen continuously during the remainder of the test by moving the loop up and down between the top and bottom of the specimen, at a regular rate of 20 complete cycles per minute.

Congelation frequently may be induced by rubbing the inner walls of the test tube with the thermometer, or by introducing a small fragment of the previously congealed substance. Pronounced supercooling may cause deviation from the normal pattern of temperature changes. If the latter occurs, repeat the test, introducing small particles of the material under test in solid form at 1° intervals as the temperature approaches the expected congealing point.

Record the reading of the test tube thermometer every 30 seconds. Continue stirring only so long as the temperature is gradually falling, stopping when the temperature becomes constant or starts to rise slightly. Continue recording the temperature in the test tube every 30 seconds for at least 3 minutes after the temperature again begins to fall after remaining constant.

The average of not less than four consecutive readings that lie within a range of 0.2° constitutes the congealing temperature. These readings lie about a point of inflection or a maximum, in the temperature-time curve, that occurs after the temperature becomes constant or starts to rise and before it again begins to fall. The average to the nearest 0.1° is the congealing temperature.

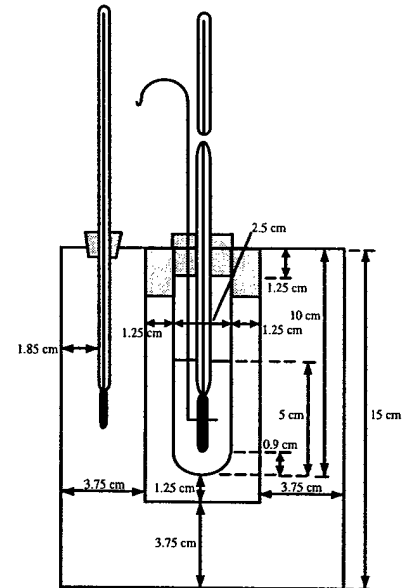

Congealing Temperature Apparatus

CSI GLP SOP
No. MAT 8-1

CAMBRIDGE SCIENTIFIC, INC.
Good Laboratory Practice Standard Operating Procedure

Date: 9 September 2002

POLY(D,L-LACTIDE-CO-GLYCOLIDE): ACQUISITION, CHARACTERIZATION, VALIDATION

Written By: _____ Reviewed By: _____
Signature Date Signature Date

Responsibility of:
Lab supervisor or someone familiar with technique

Signature Date

Lab Director

Signature Date

SUMMARY:

This GLP-SOP describes sources of supply and QA/QC protocols for the poly(lactide-co-glycolide) polymers (also called poly(lactide-co-glycolide) and abbreviated PLGA). Special emphasis is placed on PLGA-75:25.

KEY WORDS: Poly(D,L-lactide-co-glycolide)-75:25, PLGA QA/QC

VENDORS:

Alkermes, Inc.
6960 Cornell Road
Blue Ash, OH 45242-3025
tel: (513) 489-0294
fax: (513) 489-7244

Birmingham Polymers, Inc.
756 Tom Martin Drive
Birmingham, AL 35211-4467
tel: (205) 917-2231
fax: (205) 917-2240

Boehringer Ingelheim KG
BU Special Products
PO Box 200
D-55216 Ingelheim/Rhein
Germany

Materia Medica, Inc.
PO Box 4040
Rydal, PA 19046
tel: (215) 885-4205
fax: (215) 885-4205

Sithean Corporation
7814 Carousel Lane
Richmond, VA 23294
tel: (804) 346-4230
fax: (804) 346-3803

Wako Chemicals, USA, Inc.
1600 Bellwood Road
Richmond, VA 23237
tel: (804) 271-7677
fax: (804) 271 7791

Note: We now routinely obtain our PLGA's from the Boehringer Ingelheim subsidiary in the United States:

B.I. Chemicals, Inc.
Henley Division
40 Country Way
Wallingford, CT 06492
tel: (203) 265-9968
fax: (203) 265-3865

Cambridge Scientific, Inc.
180 Fawcett Street
Cambridge, MA 02138

PLGA-75:25

The specific polymer to be used as an excipient for the plasmid vaccine is a poly(D,L-lactide-co-glycolide)-75:25 [henceforth PLGA-75:25] purchased from BI Chemicals. This poly(D,L-lactide-co-glycolide)-72:25 is identified as RESOMER RG752. It has an inherent viscosity of approximately 0.16-0.24 dl/g which corresponds to a GPC weight average molecular weight of 12,000 g/mol.

QUALIFYING TESTS FOR PLGA-75:25**1a. Analytical Labs for Gel permeation Chromatography**

GPC's may be conducted by appropriate analytical labs which operate under GLP/GMP protocols

Jordi Associates
#4 Mill Street
Bellingham MA 02019
tel: (508) 966-1301
fax: (508) 966-4063

Arro Laboratory, Inc.
PO Box 686 Caton Farm Road
Joliet, IL 60434
tel: (815) 727-5436
fax: (815) 740-3234

1b. Gel Permeation Chromatography

GPC's should be run in tetrahydrofuran (50 mg/mL) against polystyrene standards. Columns are 10^4 Angstrom Ultrastayragel and ultrastayragel linear (range 2×10^3 to 4×10^6 daltons). Polystyrene standards are available through Supelco, Inc. (Supelco Park, Bellefonte, PA 16823-0048) in low mol. wt. and high mol. wt. kits containing 250 mg of each of the following molecular weights. The avg. mol. wt. is $\pm 15\%$ of the nominal value.

Low Mol. Wt. Cat. No. 4-8937	High Mol. Wt. Cat. No. 4-8938
2500 MW	110,000 MW
5000 MW	220,000 MW
9000 MW	400,000 MW
17,500 MW	600,000 MW
30,000 MW	900,000 MW
50,000 MW	1,800,000 MW

- Residual Solvent by GC Head Space Analysis
- Residual Solvent by TGA
- Nuclear Magnetic Resonance (NMR) to Verify Composition

PLGA-75:25 composition can be verified by NMR. Spectra should be taken in CD_2Cl_2 or $CDCl_3$ with tetramethylsilane (TMS) as an internal standard. Other solvents may be deuterated acetone or deuterated tetrahydrofuran.

The structure of a PLGA is given as $-[O-CH(CH_3)-CO-]_x-[O-CH_2-CO-]_{(1-x)}-$ where x = mole fraction of lactide. The NMR spectrum of PLGA is fairly simple consisting of three peaks with integrated intensities depending on the lactide:glycolide mole ratio. The peaks, their splitting, and downfield shifts from TMS, and their integrated intensity ratios for PLGA-75:25 are given below

Peak	Splitting	Shift δ ppm	Shift Hz	Integrated Intensity Ratio
Glycolide - CH2-	Singlet	4.75	288	2
Lactide - CH-	Quartet	5.15	310	1
Lactide - CH3	Doublet	1.55	95	3

Cambridge Scientific, Inc.

180 Fawcett Street
Cambridge, MA 02138

PLGA-X:Y: NUCLEAR MAGNETIC RESONANCE**Conditions**Solvent: CDCl₃

Conc: ?

Internal Std: tetramethylsilane

Sweep time: 250 seconds

Sweep width: 500 Hz

Spinning rate: 40 rps

Record peaks as well as integrated spectra

Instrument Varian AH-60

Absorptions

Origin	Position, Hz Downfield from TMS	Multiplicate	Relative Intensity	Coupling Constant, I, Hz
lactide-CH	310	quartet	1.0	8
lactide-CH ₃	94	doublet	3.0	8
glycolide-CH ₂	286	doublet	see below	3

The relative intensity of the glycolide absorbance depends on the lactide: glycolide ratio. The relative intensity of -CH₂- absorption is given in Table 1.

Table 1

Relative Intensity of -CH₂- absorption of PLGA as a function of lactide glycolide ratio (x = lactide, y = glycolide mole ratio)

x	y	-CH-	-CH ₃	-CH ₂ -
100	0	1	3	0
90	10	0.90	2.70	0.20
		1.00	3.00	0.22
85	15	0.85	2.55	0.30
		1.00	3.00	0.35
80	20	0.80	2.40	0.40
		1.00	3.00	0.50
75	25	0.75	2.25	0.50
		1.00	3.00	0.67
70	30	0.70	2.10	0.60
		1.00	3.00	0.86
60	40	0.60	1.80	0.80
		1.00	3.00	1.33
50	50	0.50	1.50	1.00
		1.00	3.00	2.00
40	60	0.40	1.20	1.20
		1.00	3.00	3.00

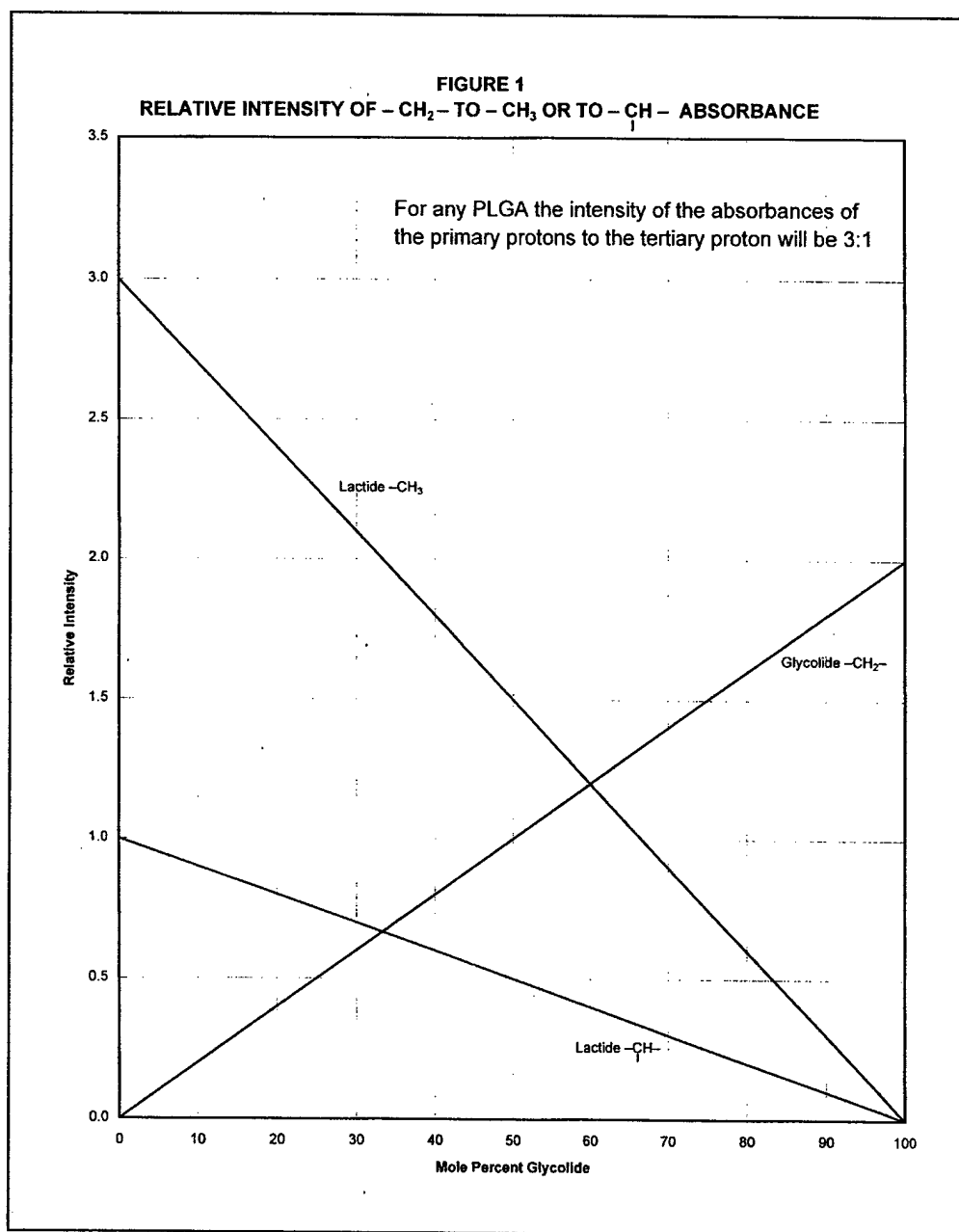

Cambridge Scientific, Inc.
180 Fawcett Street
Cambridge, MA 02138

Table 2 MR Spectra of PLGA-88:12

	δ , ppm	H	splitting	Rel. Int (mm)			
L-lactide	1.6	100	doublet	47	2.94		
	5.0	300	quartet	16	1.00		
Glycolide	4.9	296	singlet	—		(CDCL solvent)	
Sample I	1.6	308	quartet	24.0	3.69	predicted	Bt
	4.75	284	singlet (?)	6.5	1.00	3.63	1.00
	5.30	95	doublet	72.0	11.08	1.00	0.25
Sample II	1.50		quartet	22.0	3.67	10.88	3.00
	4.70		singlet (?)	6.0	1.00	3.63	
	5.20		doublet	71.0	11.03	1.00	

The two polymers in Table 2 were synthesized from a mixture containing 90% D,L-lactide and 10% glycolide by weight. The mole ratio is calculated as follows. NMR spectra of Samples I and II are given in Figures 2 and 3.

$$\text{mole \% glycolide} = \frac{(10/58.04)(100)}{10/58.04 + 900/72.06} = 12.12\% \text{ and thus mole \% lactide} = 87.85\%$$

Predicted intensities for PLGA—88:12

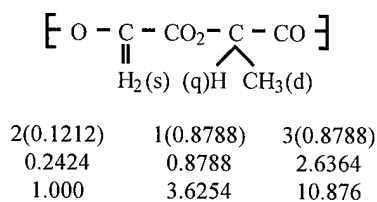
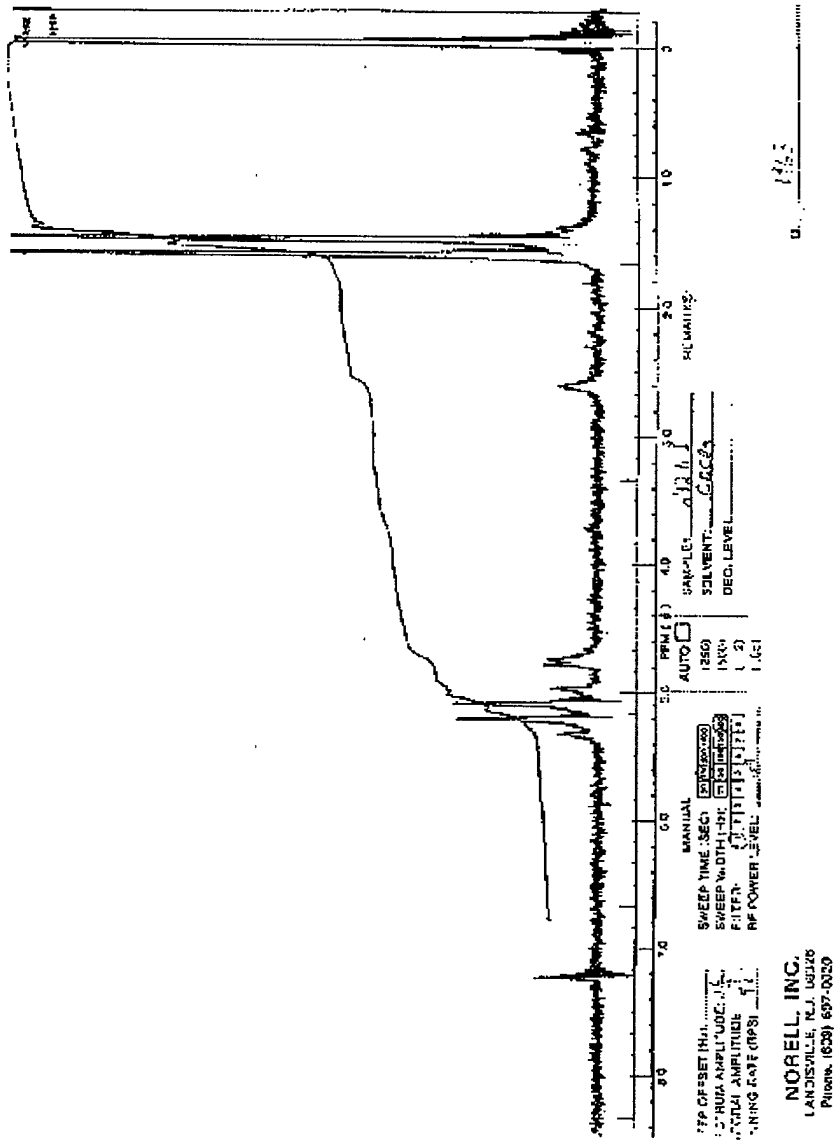

Figure 2
NMR Spectrum; PLGA-88:12 (Sample I)
Solvent CDCl₃



Cambridge Scientific, Inc.
180 Fawcett Street
Cambridge, MA 02138

H. Analysis of Polymer Composition by Nuclear Magnetic Resonance Spectroscopy

1. Introduction

Nuclear magnetic resonance (NMR) spectroscopy is a powerful tool for determining the lactide: glycolide mole ratio in PLGA's. Transitions between nuclear (proton) spin states may be induced by radio frequency (rf) irradiation of protons subject to a magnetic field. The actual magnetic field experienced by a particular proton will be affected by its chemical environment as determined by neighboring atoms and their electrons in the same molecule. And this in turn will determine the frequency of the rf radiation which will be absorbed.

The position of various NMR absorptions are usually measured relative to an arbitrary standard. A frequently used standard is tetramethylsilane (TMS), $(\text{CH}_3)_4\text{Si}$, which is added directly to the test solution. The "zero" of the spectrum is set to the single absorption of TMS, and the absorption positions of protons of the molecule of interest are reported as shifts from the TMS signal. These shifts (chemical shifts) are given in parts per million (ppm) from the frequency absorbed by TMS.

Both the position of absorption relative to TMS and the structure of the absorption band are determined by protons on neighboring atoms and their electronic environments. The NMR spectrum of glycolide (Fig. 4) shows their electronic environments. The NMR spectrum of glycolide shows a single peak about 4.8 ppm from TMS. The glycolide moiety in PLGA appears as a doublet also at about 4.8 ppm. (Note that the glycolide protons are in almost identical environments in both glycolide and PLGA.)

The lactide moiety in PLGA as well as in the lactide dimer has two proton environments: the methyl group appears as a doublet at about 1.6 ppm relative to TMS and the single proton on the carbon alpha to the carboxyl group as a quartet at about 5.0 ppm. The NMR spectrum of L-lactide is shown in Fig. 5.

NMR spectra of PLGA's should be taken in dry deuteriochloroform, CDCl_3 . Note that the deuterium isotope of hydrogen does not absorb rf radiation and therefore does not give rise to an NMR signal. However, a weak band at about 7.2 ppm may also be observed due to a CHCl_3 impurity in the CDCl_3 .

After recording the NMR absorption spectrum, the NMR spectrometer should also be operated in the integration mode. This will give a tracing which parallels the base line until it passes through an absorption band. The pen will then rise and resume a horizontal path until it passes through another band, and so on. The difference in heights (measured in any convenient linear units) before and after each peak is proportional to the number of protons giving rise to that peak. Thus, the integrated spectrum is needed to calculate the mole percent composition.

2. Equipment and Conditions for Taking NMR Spectra

Instrument: Varian AH-60 or equivalent

Solvent: Deuterated chloroform, CDCl_3

Sweep time: 250 seconds

Sweep width: 500 Hz

Spinning rate: 40 revolutions per second

Internal standard: tetramethyl silane

Polymer solution concentration: approximately 20-40 mg/mL

Record both NMR absorption spectrum and integrated spectrum

3. Expected Peaks and Relative Intensities for 90:10 and 85:15 PLGAs.

Figures 4 and 5 are NMR spectra of glycolide and lactide. Note the single glycolide peak, a singlet. The lactide spectrum consists of a quartet and a doublet. The integrated spectrum rises through the quartet from the left, remains fairly constant until it reaches the doublet whereupon it rises again. The rises are indicated as hq and hd. The ratio hd/hq was measured in centimeters on the full scale spectrum as $4.7/1.6 = 2.94$. This differs from the expected ratio of 3.0 by only 2.0%. Note that in lactide the ratio of the number of methyl group protons to the number of protons on the alpha carbons as 3:1.

Figure 6 is an NMR spectrum of PLGA's comprised of 90% by weight of L-lactide and 10% by weight of glycolide. This corresponds to 87.9 and 12.1 mole percents respectively. Table 2 gives the relevant NMR intensities for the three polymers.

NMR Relative Spectral Intensities for three 90:10 PLGA's* (* composition in weight percent)

Type of Proton	Number of Protons	Relative Intensity			Calc. Mole % Glycolide
		Polymer 1	Polymer 2	Polymer 3	
lactide -CH-	1	24.0	22.0	22.0	11.9, 11.8
glycolide -CH ₂	2	6.5	6.5	7.0	12.9, 11.8
lactide -CH ₃	3	73.0	73.0	69.0	13.7, 13.2
	Mean Mole %			Glycolide	12.7 ± 0.8

The mean glycolide content, 12.7 mole percent, agrees quite closely with the expected value of 12.1%. The accuracy of this determination is to be taken to be +10% and serves as a check on the compositions obtained by IR spectral analysis.

The mole fraction of glycolide in PLGA may be calculated from either of the following intensity relationships:

$$F_g = [0.5I_{\text{aCH}_2} - I] / [I(-\text{CH}-) + 0.5I_{\text{aCH}_2} - I] = [1.5I_{\text{aCH}_2} - I] / [1.5I(-\text{CH}-) + I_{\text{aCH}_3}]$$

where F_g is the mole fraction of glycolide in the polymer and $I(-)$ represents the intensity of absorption of the protons indicated in the parentheses as determined from the integrated spectrum.

The expected relative intensities in a PLGA containing 15 mole% glycolide are given below:

Type of Proton	Expected Relative Intensity in 85:15 - PLGA
lactide -CH-	2.8
glycolide -CH ₂ -	1.0
lactide -CH ₃ -	8.5

Figure 7 is an NMR of the 85:15 PLGA (Boehringer-Ingelheim Resomer 858, Lot 25024).

4. Obtaining the Relative Intensities

The intensities of the peaks are found from the integrated spectrum as shown in Fig. 7.

1. Continue the lower portion of the integration line parallel to the base line and end this extension just past the peak of interest.
2. The integration line rises through the peak of interest and then returns to the horizontal just after the peak. Measure the change in height of the integration line from just before or just after the peak. Use a centimeter rule with millimeter divisions and measure the height to the nearest millimeter.
3. Do this for the three peaks belonging to the polymer. Note: doublets, quartets, as well as singlets, are taken as components of a single peak.
4. The change in height for any peak will be directly proportional to the number of protons of that type in the polymer.

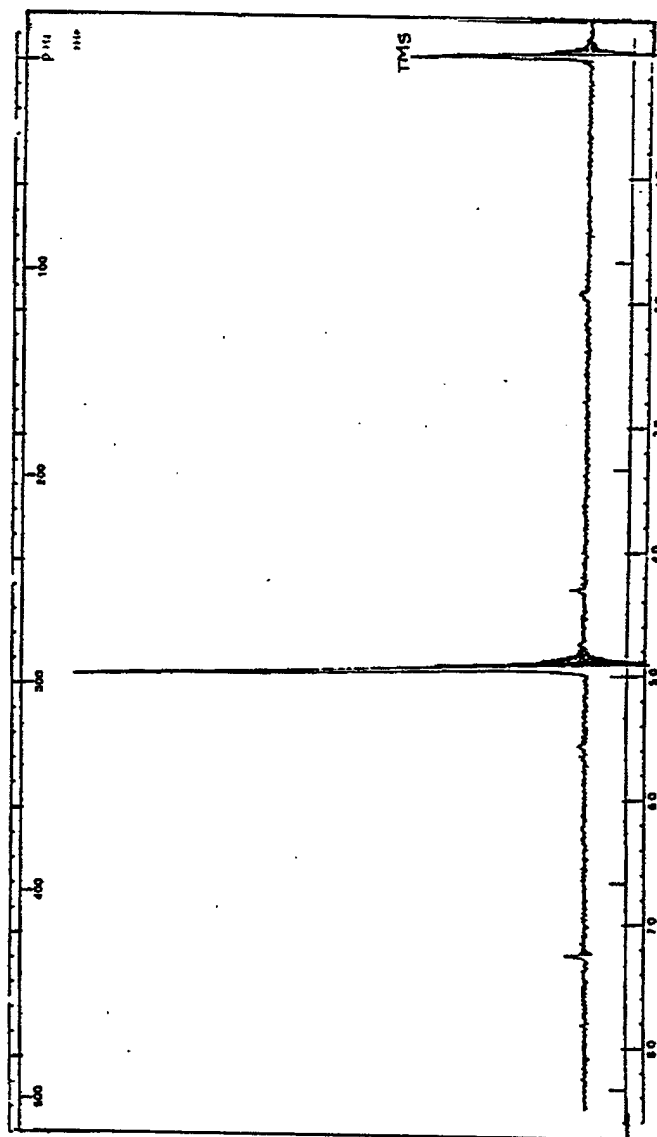

Figure 4: GLYCOLIDE NMR SPECTRUM IN $CDCl_3$

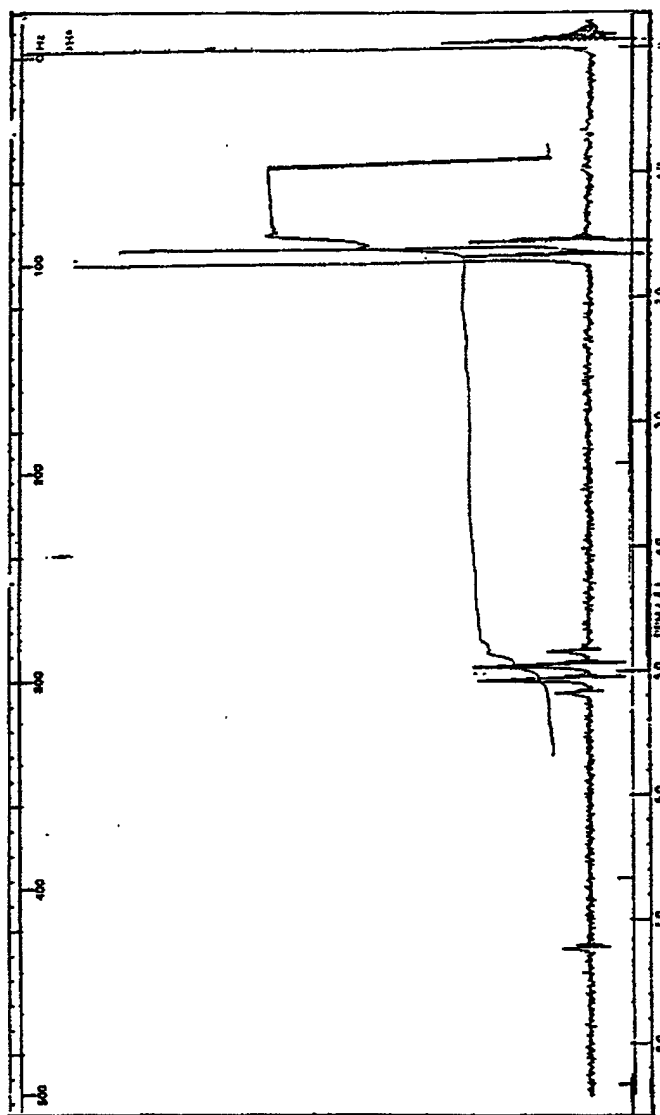

Figure 5: L-LACTIDE NMR SPECTRUM IN CDCl₃

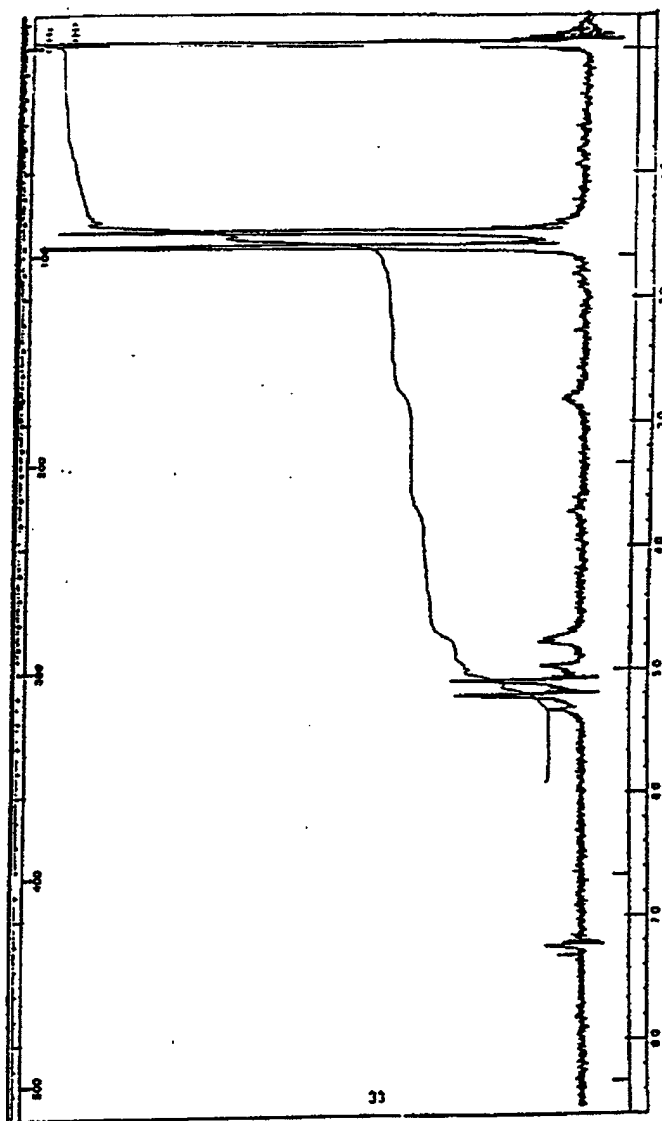

Figure 6: NMR SPECTRUM OF PLGA-88:12
Poly(L-lactide-co-glycolide)

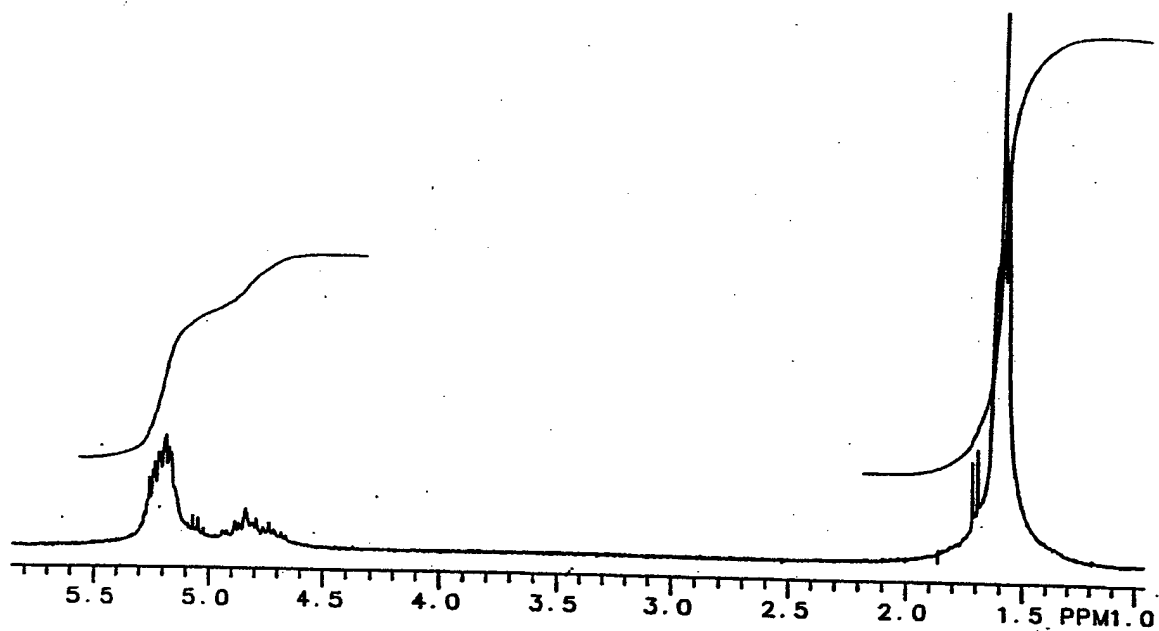

Figure 7

NMR SPECTRUM OF RESOMER 858
Boehringer-Ingelheim
Poly(D,L-lactide-co-glycolide) 85:15
Lot 25024
CSI 39-27 (27 Oct 1992)

**CSI GLP SOP
No. MAT 9-1**

**CAMBRIDGE SCIENTIFIC, INC.
Good Laboratory Practice Standard Operating Procedure**

Date: 9 September 2002

PURIFICATION OF PLGA'S BY PRECIPITATION

Written By: _____ Reviewed By: _____
Signature Date Signature Date

Responsibility of:
Lab supervisor or someone
familiar with technique

Signature Date

Lab Director

Signature Date

SUMMARY:

This GLP-SOP describes purification of poly(lactide-co-glycolide)s of varying composition by solution in an appropriate solvent followed by precipitation into a liquid which is miscible with the PLGA solvent but which is itself a non-solvent for the PLGA.

NOTE: All of Boehringer Ingelheim's (B.I.) resorbable polymers of the RESOMER product line are manufactured according to cGMP guidelines. B.I. is also ISO 9001 certified. Thus, these polymers do not have to be purified for use in implants designed for human use solely on the basis of their purity. If purification is thought to be desirable, the following methodologies may be applied.

KEY WORDS: Poly(lactide-co-glycolide, purification, precipitation

METHOD

1. Make a solution of PLGA in methylene chloride (MC) so that the concentration is 45-55 mg/mL. Thus to purify 10 grams, use 200 mL of MC.
2. Slowly add this solution from a separatory funnel to the precipitant chilled reagent grade, isopropyl alcohol (IPA). About 200 mL of the IPA should be contained in a 500 mL beaker equipped with a magnetic stirring bar. The PLGA solution should be added dropwise to the stirred IPA (or use 1 liter of IPA in a 2 liter beaker).
3. Collect the fibrous PLGA precipitate as it forms on a glass rod held in the stirred solution. Collect only 250-500 mg at a time.
4. When the IPA begins to become cloudy, discard it and use fresh IPA. Use only about 100 mL of polymer solution to about 500 mL IPA.
5. Allow the fibrous cocoons to drain and dry on an absorbant material (Benchkote, Fisher 12-007) for at least 24 hours.
6. Further dry under vacuum (≤ 1 mm Hg) at room temperature for at least 48 hours.

Other solvent/precipitant combinations may be used.

Solvent	Precipitant
tetrahydrofuran	IPA or water
acetone	IPA or water
gl HAC	IPA or water

Cambridge Scientific, Inc.
180 Fawcett Street
Cambridge, MA 02138

7. Test for residual solvents (MC, IPA) by gas chromatography (head space analysis).
8. If either solvent or precipitant is present in more than ___ ppm, continue vacuum drying until within established limits.

As an example PLGA-75:25 may be purified as follows:

ALTERNATIVE PURIFICATION PROTOCOL

- Dissolve 10 grams of 75:25 PLGA in 200 ml of reagent grade acetone
- Slowly add the above solution to 1L of reagent grade 2-propanol with continuous stirring
- Remove fibers from solution utilizing a glass stirring rod and place them in paper towels to dry at room temperature at least 24 hours
- Vacuum dry fibers at pressure less than 1 mm Hg at room temperature for 48 hours before use.
- Place fibers in vacuum dessicator

CSI GLP SOP
No. MAT 7-1

CAMBRIDGE SCIENTIFIC, INC.
Good Laboratory Practice Standard Operating Procedure

Date: 22 April 1998

RESIDUAL ACETIC ACID IN PLGA FOAM BY Ph MEASUREMENT
AFTER LYOPHILIZATION AND GRINDING TO $\leq 125 \mu\text{m}$

Written By: _____ Reviewed By: _____
Signature Date Signature Date

Responsibility of:

Lab supervisor or someone
familiar with technique

Signature Date

Lab Director

Signature Date

SUMMARY:

This GLP-SOP describes QA/QC protocols for determination of residual acetic acid in polymer foams after lyophilization and grinding. The residual Hac is determined by pH measurement.

KEY WORDS: Residual acetic acid, polymer foam

EQUIPMENT:

pH meter, standard calibration solutions (pH 4.0 and 7.0), 25 or 50 ml plastic beaker, stirring bar, magnetic stirrer.

PROCEDURE:

1. Standardize pH meter with pH4 and pH7 standard solutions
2. Check pH of distilled or deionized water. An acceptable range is $6.5 \leq \text{pH} \leq 7.5$. If outside these limits, boil the water, cool, purge with nitrogen gas, and remeasure the pH.
3. Weigh 100 ± 5 mg of the ground PLGA and stir into 10 ml of the distilled or deionized water contained in a small plastic beaker equipped with a teflon enclosed magnetic stirring bar. Place on magnetic stirrer and stir. Allow to come to equilibrium for 10 minutes.
4. Measure pH of polymer/water mixture. Accept if $\text{pH} \geq 5.0$ (approximately 100 ppm). If pH is lower, the polymer must be further vacuum dried.

CALCULATIONS:

The calculation is based on a dissociation constant for acetic acid: $K_{HAc} = 1.8 \times 10^{-5}$. The assumptions are:

- All Hac in the PLGA goes into solution
- No PLGA degradation occurs during the measurement
- PLGA does not contribute hydrogen ion to the solution
- Negligible hydrogen ion contribution from other sources

Cambridge Scientific, Inc.
180 Fawcett Street
Cambridge, MA 02138

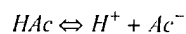

$M - x \quad x \quad x$ where $M = [\text{HAc}]_0$, $x = [\text{H}^+]$, $[\text{Ac}^-]$ moles/liter

and $x = 10^{-\text{pH}}$

$$K = x^2 / (M - x) \text{ and } M = (wf/v) / 60.05$$

w = weight of PLGA = 100 mg

f = weight fraction of HAc in the PLGA (pph of HAc)

v = volume of water = 10 ml

60.05 g/mole = mol. wt. of HAc

Thus $x^2 + 1.8 \times 10^{-5}x - 1.8 \times 10^{-5}M = 0$ from which the following table may be computed.

Wt % HAc	f	ppm	$M = 0.1665f$	$x = [\text{H}^+]$	pH
2.0	0.02	2×10^4	3.330×10^{-3}	2.3600×10^{-4}	3.627
1.0	0.01	10^4	1.665×10^{-3}	1.6435×10^{-4}	3.784
0.5	0.005	5×10^3	8.325×10^{-4}	1.1374×10^{-4}	3.944
0.1	10^{-3}	10^3	1.665×10^{-4}	4.6480×10^{-5}	4.333
0.01	10^{-4}	10^2	1.665×10^{-5}	1.0512×10^{-5}	4.978
0.001	10^{-5}	10^1	1.665×10^{-6}	1.5342×10^{-6}	5.814
0.0001	10^{-6}	10^0	1.665×10^{-7}	1.6499×10^{-7}	6.783

APPENDIX I

CAMBRIDGE SCIENTIFIC, INC. GOOD LABORATORY PRACTICES METHODS STANDARD OPERATING PROCEDURES

MEASUREMENT OF IN VITRO RELEASE OF PLASMID DNA

**PREPARATION OF 0.01M PHOSPHATE BUFFERED SALINE (PBS),
pH 7.0–7.4**

PLGA FOAM PREPARATION BY LYOPHILIZATION

EXTRUSION OF PLGA/PLASMID DNA RODS

GRINDING, PACKAGING, AND LABELING OF EXTRUDED RODS

**ANALYSIS OF RESIDUAL ACETIC ACID IN EXTRUDED RODS BY GAS
CHROMATOGRAPHIC HEAD SPACE EXTRACTION**

CSI GLP SOP
No. MTH 10-1CAMBRIDGE SCIENTIFIC, INC.
Good Laboratory Practice Standard Operating Procedure

Date: 17 January 2003

MEASUREMENT OF IN VITRO RELEASE OF PLASMID DNA

Written By: _____ Reviewed By: _____
Signature Date Signature DateResponsibility of:
Lab supervisor or someone
familiar with technique_____
Signature Date

Lab Director

Signature Date**SUMMARY:**

This GLP-SOP describes measurement of the *in vitro* release of plasmid DNA (pDNA) into phosphate buffered saline by ultraviolet/visible spectrophotometric analysis

KEY WORDS: *In vitro* release, plasmid DNA, pDNA, ultraviolet/ visible spectrophotometric analysis

METHOD

1. Adjust the PolyScience Shaking water bath (Model SH 28L) to 37 °C and 60 cpm.
2. Prepare five (5) samples consisting of 10.0 (±0.1) mg microparticles containing impregnated DNA.
3. Place microparticles into 2.0 mL microcentrifuge tubes.
4. Add 1.5 mL of phosphate buffered saline to each tube and close cap.
5. Place upright or at a slight slant in a large beaker containing sufficient water so that the water level in the beaker is above the water level in the test tubes.
6. Collect supernatant at 1 and 4 hours and at 1, 3, 7, 14, 21, 28, 35, 42, 49, and 56 days.
7. Prepare negative controls consisting of PLGA microparticles prepared without plasmid.

SPECTROPHOTOMETRIC MEASUREMENTS AND CALCULATIONS

1. Measure UV absorbance for each supernatant solution at 260 (A260) and 280 (A280) nm against a phosphate buffered saline background. Dilute samples with saline if the absorbance at 260 nm is greater than 1.0 and measure the absorbance of the diluted solution.
2. Calculate the concentration of plasmid in the solution by comparing the value of A 260 against a calibration curve generated for known concentrations of plasmid in saline.

Cambridge Scientific, Inc.
180 Fawcett Street
Cambridge, MA 02138

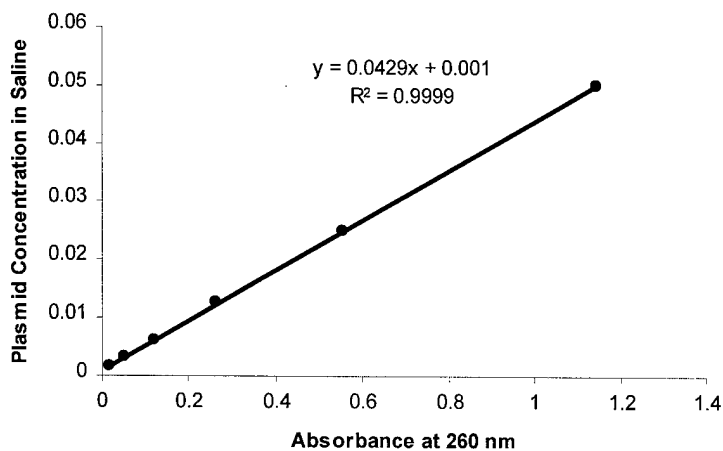

Representative calibration curve for VR2578 plasmid in phosphate buffered saline.

3. Calculate the cumulative fraction of plasmid released

Symbols

V_t = total volume of solution

v_i = volume of i^{th} sample removed for analysis and replaced with an equal volume of fresh buffer

A_i = absorbance of i^{th} sample

m_∞ = initial mass of PLGA microparticles

m_n = mass of plasmid released by the n^{th} time point

c = concentration of plasmid in solution at n^{th} time point

ϵ = extinction coefficient of plasmid

f_i = dilution factor

F = cumulative fraction released at n^{th} time point

Fraction released at n^{th} time point $F = m_n/m_\infty$

Now $A = \epsilon cd$ (let $d = 1$ cm)

and $c = A / \epsilon$

and $m = cV = AV / \epsilon$

It can be shown that the cumulative fraction released at the n^{th} time point is given by the following equation in which subscript i refers to measurements at previous time points.

$$F = \frac{m_n}{m_\infty} = \left[A_n f_n V_t + \sum_{i=1}^{n-1} A_i f_i V_i \right]$$

4. Calculation of cumulative fraction released if aliquot samples taken for analysis are returned to the test tube.

In this case $F_n = A_n V / \epsilon m_\infty$

5. Criteria for batch acceptance.

- The cumulative fraction of plasmid released through 4 hours must be <25 percent.
- The ratio of A260/A280 must be between 1.7 and 2.0 for all periods.

Cambridge Scientific, Inc.

180 Fawcett Street
Cambridge, MA 02138

CSI GLP SOP
No. MTH 11-1

CAMBRIDGE SCIENTIFIC, INC.
Good Laboratory Practice Standard Operating Procedure

Date: 17 January 2003

PREPARATION OF 0.01M PHOSPHATE BUFFERED SALINE (PBS), Ph 7.0-7.4

Written By: _____ Reviewed By: _____
Signature Date Signature Date

Responsibility of:
Lab supervisor or someone
familiar with technique

Signature Date

Lab Director

Signature Date

SUMMARY:
This GLP-SOP describes preparation of phosphate buffered saline for *in vitro* studies.

KEY WORDS: *In vitro* release, plasmid DNA, pDNA, ultraviolet/ visible spectrophotometric analysis

REFERENCE:
Williams, CA and Chase, MW (eds.), *Methods in Immunology and Immunochemistry*, Volume II, Physical and Chemical Methods, Appendix II page 401, Academic Press, 1968

METHOD: See attached

**Preparation of 0.01M Phosphate Buffered Saline (PBS), pH 7.0
From Methods in Immunology and Immunochemistry, Vol. II***

I. Components

1. Sodium phosphate, dibasic, anhydrous; Na_2HPO_4
 - mol. wt. 141.98g, hygroscopic, requires 8.0 ml H_2O /gram to dissolve,
 - dry at $110^\circ\text{--}130^\circ\text{C}$ for 2 hours,
 - keep container tightly sealed to prevent hydration
2. Sodium phosphate, monobasic, monohydrate; $\text{NaH}_2\text{PO}_4 \cdot \text{H}_2\text{O}$
 - mol. wt. 138.01g, requires 1.0ml H_2O /gram to dissolve.
3. Sodium chloride, NaCl
 - mol. wt. 58.46g, requires 2.8 ml H_2O /gram to dissolve,
 - dry at 160°C .
4. Deionized, degassed water, H_2O

II. Preparation of Stock Solutions in 1-liter Volumetric Flasks:

Solution A: 0.2M $\text{Na}_2\text{HPO}_4 \cdot \text{H}_2\text{O}$ 27.60 g/liter H_2O ;

Solution B: 0.2M $\text{NaH}_2\text{PO}_4 \cdot \text{H}_2\text{O}$ 28.39 g/liter H_2O

III. For One Liter of PBS:

- Combine 16.5ml Solution A and 33.5 ml Solution B in a 1-liter volumetric flask,
- Add 7.40g dried NaCl ,
- Add H_2O to one liter,
- Check pH using calibrated meter and adjust to 7.0 if necessary.

IV. To make x liters, use the following weights in grams

component	$x = 0.5$	1.0	2.0	4.0
Na_2HPO_4 , g	0.9480	1.8940	3.7880	7.5760
$\text{NaH}_2\text{PO}_4 \cdot \text{H}_2\text{O}$, g	5.0005	10.0193	20.0020	40.0040
NaCl , g	2.2014	4.4000	8.000	17.6000

Make up to within 10% of final volume with distilled or deionized water. Adjust pH to 7.4 ± 0.05 with hydrochloric acid or sodium hydroxide solution. The concentration of these should be ≤ 0.10 M. Then make up to final volume.

* Williams, Curtis A., and Merrill W. Chase, (eds.), Appendix II, *Methods in Immunology and Immunochemistry*, Volume II, Physical and Chemical Methods, pg. 401, Academic Press, 1968.

CSI GLP SOP
No. MTH 12-1CAMBRIDGE SCIENTIFIC, INC.
Good Laboratory Practice Standard Operating Procedure

Date: 17 January 2003

PLGA FOAM PREPARATION BY LYOPHILIZATION

Written By: _____ Reviewed By: _____
Signature Date Signature DateResponsibility of:
Lab supervisor or someone
familiar with technique_____
Signature Date

Lab Director

Signature Date**SUMMARY:**

This GLP-SOP describes the preparation of foams of poly(D,L-lactide-co-glycolide) by lyophilization of solutions of the polymer in glacial acetic acid.

KEY WORDS: PLGA, foam, lyophilization**A. EQUIPMENT:**

Labconco Freeze Dryer 8; Labconco Fast-Freeze Flasks (Labconco No. 75400 to 75412 corresponding to ; Fisher No. 10-269-50 to 56 for complete assemblies); Labconco adapters for connecting assemblies to freeze dryer valves (Labconco Nos. 75450 to 75460 (Fisher 10-269-57A to 59B) or 75470 to 75476 (Fisher 10-269-60A to 10-269-61B))

B. PLGA FOAM AND LYOPHILIZATION PROTOCOL

1. To make a specified foam use the appropriate type of PLGA poly(lactide-co-glycolide) polymer. 3.75 grams of polymer is required for a standard size foam in a (100 ml) lyophilization flask. The amount of polymer will vary according to the size of foam needed.
2. The polymer is dissolved with 75 ml of glacial acetic acid into the bottom half of the lyophilization flask. (The ratio of polymer to glacial acetic acid is 50 mg/ml).
3. Make sure to cover the flask with parafilm once the polymer is added to the glacial acetic acid. This is to prevent spills and loss of glacial acetic acid due to evaporation. The polymer will fully dissolve in about 3 hours. This process takes place at room temperature using a stir bar and a stirring hot plate.
4. Once the polymer is dissolved into the acid remove the stir bar and place the flask with the parafilm cover into the freezer (-10°C) for at least 5 hours or overnight, preferably.
5. Set up the lyophilization apparatus, (as shown), so the acetic acid can be removed from the frozen solution and the foam can form.
6. Maintain vacuum pressure below 1 mmHg at all times.

Cambridge Scientific, Inc.
180 Fawcett Street
Cambridge, MA 02138

7. Keep samples on freeze drier for approximately 48 hours.
8. After the foam has been prepared remove foam from the flask for further testing. This includes gas chromatography for residual glacial acetic acid. (See SOP-MTH8-1).

C. OPERATION OF LABCONCO FREEZE DRYER 8

- Check vacuum pump oil condition and quantity before starting pump. Change oil if dirty or cloudy.
- Operate vacuum pump with ballast open to purge oil of any accumulated wastes.
- Turn on refrigeration before vacuum pump. Do not proceed unless temperature is -40°C or lower. Do not apply sample until no load vacuum is ≤ 25 micron (in the green)
- Turn off machine in following sequence:
 1. Break vacuum.
 2. Turn off pump.
 3. Turn off refrigerator.
 4. Defrost drain and dry condenser.
- Replace gasket and plexiglass plots. Use silicone vacuum grease to get a good seal (Dow Corning High Vacuum Grease)

Note:

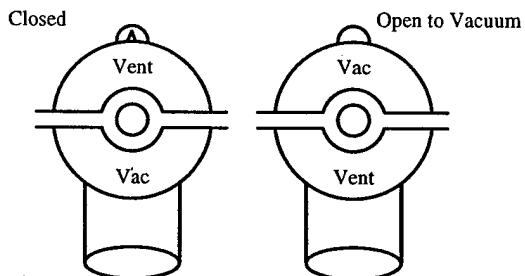

**CSI GLP SOP
No. MTH 13-1**

**CAMBRIDGE SCIENTIFIC, INC.
Good Laboratory Practice Standard Operating Procedure**

Date: 17 January 2003

EXTRUSION OF PLGA/PLASMID DNA RODS

Written By: _____ Reviewed By: _____
Signature Date Signature Date

Responsibility of:
Lab supervisor or someone familiar with technique

Signature Date

Lab Director

Signature Date

SUMMARY:

This GLP-SOP describes extrusion of 1.2 mm rods containing 1% by mass plasmid in a PLGA excipient. Variations of the method are given for use of both the Enerpac and Compac presses.

KEY WORDS: Extrusion , PLGA, Plasmid DNA, DNA

REFERENCE:

SOP EQP 1-1, 2-1, 3-1

EQUIPMENT:

- Enerpac 100 ton hydraulic press, (or Compac Model MPC 40-1 (Table model) or MPC 40-1D-3 (floor model), 2.5 inch OD mold/die/ram assembly with 1.2 mm diameter die. and 1 inch dia. ram.
- 8 mm (5/16 inch) Allen wrench
- Enerpac 100 ton hydraulic press with support plate
- Omega Engineering CN380 Series Temperature Controller and CN382 Solid State Relay (SSR)
- 1.5 inch heating collar: Code MBJ1JN1, Watlow Electric Co. (St. Louis)
- Digital thermometer, Model DP 116-JC2, Omega Engineering, Inc. (Stamford, CT)
- Type J thermocouple wire
- Rubber latex gloves, hemostat

Rod length, cm	weight of charge, grams	height of charge in mold, cm
25	0.462	0.076
50	0.924	0.152
75	1.385	0.228
100	1.847	0.304
200	3.694	0.608
500	9.235	1.520

NOTE: *The relations between weight of charge to the mold, length of extruded 1.4 mm diameter rod and the height the compacted charge will occupy initially in the 1" diameter mold is given above.*

METHOD I

(Emphasis is on Enerpac Hydraulic Press. When using the Compaq press see Method II.)

1. Make sure all items which will contact the charge are clean (see SOP EQP 8-1). Wear rubber latex gloves.
2. Assemble mold with thermocouple in place.
3. It is desirable, although optional, to remove the static charge from the mold assembly and from the container in which the plasmid/PLGA powder (the charge) is stored. This may be done by dipping the items momentarily in liquid nitrogen (do not cool excessively). Or the items may be exposed to an air ionizer such as the Small Air Ionizer (marketed by McMaster-Carr, Cat. No. 2240 K33.)
4. Mass the requisite quantity of charge into a plastic weighing dish. Plan for a small excess of about 10%. Transfer the charge to the mold and insert ram.
5. Place the steel support across the moveable frame of the Enerpac under the cylinder. Place over the hole in the plate a cardboard sheet (not corrugated and approximately 1 mm (0.04 in) thick) over the steel support. This will serve as thermal insulation. The cardboard sheet should have a 0.5 inch diameter hole in it which is to be centered over the hole in the support.
6. Place the mold assembly on the cardboard and place the heating collar over the mold. Tighten the collar gently around the mold.
7. Electrical connections
 - Connect the heating collar to the variable transformer. Make sure the on-off switch is set to zero as well as the dial setting before plugging the transformer into a 120 volt AC power line.
 - Connect the digital thermometer to a 120 volt AC power line.
 - Make sure that the Enerpac on-off switch is in the off position before connecting the press to a 120 volt AC, single phase, 30 amp circuit.
8. Align the steel support plate, cardboard insulator, and mold assembly under the cylinder. Gently lowering the cylinder to nearly the top of the ram (see SOP EQP 3-1) will facilitate alignment.
9. Set the Enerpac to a minimum reading of 5000-7000 lbs on the gauge. This will compact the charge while raising the temperature of the mold.
10. Turn on the autotransformer. Raise the dial setting to 15 and allow the temperature to equilibrate. Thereafter raise the dial setting by 5 units and allow temperature to equilibrate before the next increase. The final temperature should be 45 to 55 °C.
11. When the temperature reaches 45-50°C, increase the force to 20,000.
12. When the temperature reaches 45-50°C, the matrix should begin to extrude.
13. When about one inch of matrix has been extruded, attach a hemostat to the protruding end to maintain a small but constant temperature on the rod. Wear rubber latex gloves when handling rod.
14. Monitor the pressure and temperature at least every 15 minutes during the extrusion and maintain both within the prescribed limits.

METHOD II

(When using either of the Compac Hydraulic Presses (Model MPC-40-1 (table model) or MPC-40-1D-3 (floor model))

NOTE: *The following describes only the operation of the Compac presses. Details of the extrusion are the same as described in Method I.*

1. The Compac presses require 220 volt AC, 3 phase power source.
2. The press is equipped with a support with a V-shaped slot. Over this place the 6" × 2" × 0.5" steel support with the 0.75" inch diameter hole.
3. Turn on the press using the green ON button.
4. Make sure the pressure control screw is turned counterclockwise. This will allow the cylinder to be moved to the surface of the mold without applying pressure.
5. To set pressure on the mold lower the cylinder by depressing the lever on the right side (facing it) of the press.
6. With the lever depressed, place the pin in the hole of the cylindrical disc from which the lever protrudes. This will lock the lever in place.

Cambridge Scientific, Inc.
180 Fawcett Street
Cambridge, MA 02138

7. Turn the pressure control screw clockwise until the pressure gauge indicates the desired pressure. This pressure will now be maintained.
8. When finished turn the pressure control screw counterclockwise until pressure is removed.
9. Remove the locking pin of the cylinder control lever and raise the cylinder by raising the lever. Turn the power OFF (red button).

PROCEDURE FOR EXTRUSION

1. Assemble mold.
2. Immerse container with the plamid/PLGA mixture into liquid nitrogen momentarily. (Do not freeze it.) This removes static electrical charge.
3. Load the mold with about 4.7 grams of the plamid/PLGA mixture. This may be massed out first in a clean plastic weighing dish.
4. Insert the ram and wrap with the heating tape.
5. Place entire assembly in an oven preheated to 45–50°C until ready for use.
6. When ready to extrude remove from oven and mount on the bench of the Compac with the exit orifice is over and open part of the V in the bench. Make sure the Compac is properly connected to a 120 volt, 3-phase power source.
7. Plug the heating tape into the Powerstat. Make sure that the Powerstat is set to zero and is turned off. Connect the thermocouple to the Digital Thermometer and insert the junction end of the thermocouple into the receptacle in the mold. Connect the Powerstat and Digital thermometer to a 120 volt AC power source.
8. Set the Compac to 10 tons load. This corresponds to 20,000 pounds on the 1" diameter ram. Turn the Powerstat on and set to 35 and wait until the digital thermometer reads 45–50°C.
9. Raise the Powerstat slowly over an interval of 15–20 minutes to a setting of 45–50. Allow temperature to equilibrate before raising the setting. The temperature should be between 46–48°C when the matrix begins to extrude.
10. When the matrix has extruded about one inch attach a hemostat to the protruding end to maintain a small but constant tension on the rod. Wear rubber latex gloves when handling rod.

PROTOCOL FOR EXTRUSION OF RODS

1. Materials to be extruded (polymer, etc.) have been previously ground and mixed. The mold size and "die" diameter are chosen according to the diameter of the rod required and accounts for a 20% die swell.
2. Clean all parts of the mold with acetone and allow them to air dry.
3. Assemble the mold and tighten the screws in bottom (see attached diagram). The flat part of the die sits with the hole facing outward. A small plug of parafilm is used to temporarily stopper the bottom of the die.
4. Carefully add the compound to the mold through a funnel. The ram is inserted slowly—so as not to disturb the solid.
5. Turn on the press and center the die and mold. Compress to flatten solid (1—5 mins, up to 5 tons). Remove the parafilm plug.
6. Attach the thermocouple around the mold to monitor the temperature of the extrusion. Place the heater between the two pieces of mold where the polymer material sits.
7. Apply pressure up to 10 tons. **DO NOT EXCEED 15 TONS ON THE MACHINE.**
8. Wait and observe—monitor and record the temperature, check for appearance of the rod from the bottom of the mold.
9. After appearance of about 2 inches of rod, attach weight (to tip of rod, approx. 180g for 1.55 mm diameter) with tweezers to keep the rod straight.
10. When extrusion is complete, remove rod, allow mold to cool, disassemble and clean.

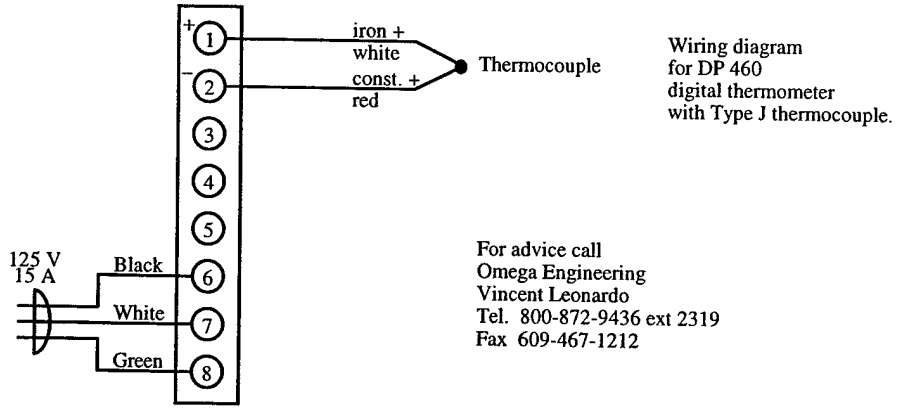
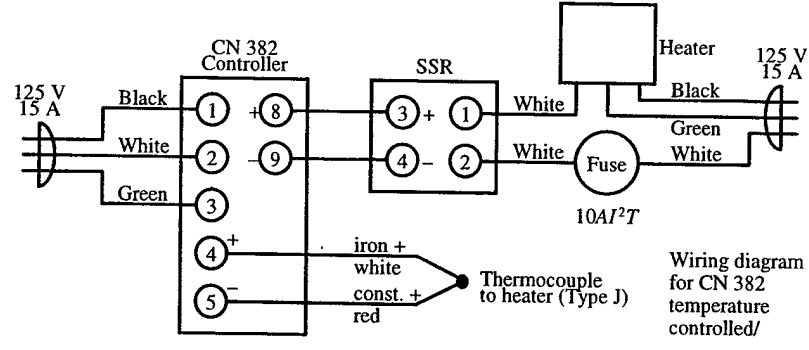

For advice call
 Omega Engineering
 Vincent Leonardo
 Tel. 800-872-9436 ext 2319
 Fax 609-467-1212



Servicing USA and Canada: Call OMEGA Toll Free

USA
 One Omega Drive, Box 4047
 Stamford, CT 06907-0047
 Telephone: (203) 359-1660
 FAX: (203) 359-7700

Canada
 976 Bergat
 Laval (Quebec) HTL 5A1
 Telephone: (514) 856-6928
 FAX: (514) 856-6886

Sales Service: 1-800-826-6342 / 1-800-TC-OMEGA™
 Customer Service: 1-800-622-2378 / 1-800-622-8181™
 Engineering Service: 1-800-872-9436 / 1-800-USA-WHEN™
 RTD/EX: 926404 - BAS™: 926404 - CABLE: OMEGA

Head Office Europe, United Kingdom Sales and Distribution Center
 P.O. Box 100, Broomfield, Essex, S.S.16 5YU, England
 Tel: (0459) 223112 Fax: (0459) 223912

Omega's complete Measurement and Control Handbooks & Encyclopedias
 Data Acquisition Systems
 Electric Heaters
 Environmental Monitoring
 and Control



Get Your FREE Handbook Request Form Today: (203) 359-RUSH

**TABLE OF CONTENTS
 CN380 SERIES CONTROLLERS**

SECTION	PAGE
SECTION 1 INTRODUCTION	1
1.1 General Description	1
1.2 Ordering Information	1
SECTION 2 INSTALLATION	2
2.1 Unpacking	2
2.2 Mounting	3
2.3 Terminal Arrangement and Wiring	3
SECTION 3 OPERATION	5
3.1 Controls and Indicators	5
3.2 DIP Switch Settings	7
3.2.1 Input Range - T/C, RTD, Voltage, mV, Current	8
3.2.2 RTD Alpha Values	10
3.2.3 Centigrade or Fahrenheit	10
3.2.4 Heating/Cooling Output Characteristics	10
3.2.5 Absolute Value/Deviation Alarm Setting	10
3.2.6 Alarm ON at all times/Alarm OFF Temporarily	10
3.3 Setting Selection Using Front Keypad	10
3.3.1 Entering the Set Point	12
3.3.2 Output (Control Level) Monitor (P, I, D)	12
3.3.3 Setting Proportional Band	12
3.3.4 Setting Integral Time	13
3.3.5 Setting Derivative Time	13
3.3.6 High/Low Alarm	13
3.3.7 Proportional Cycle	13
3.3.8 Deadband Option	13
3.3.9 Control Deadband	13
3.3.10 Sensor Compensation	13
3.3.11 Decimal Point Position for Voltage/ Current Input	14
3.3.12 Display for Voltage/Current Input	14
3.3.13 High/Low Alarm Limit for Thermocouple and RTD	14
3.3.14 Key Lock and Unlock	14
3.3.15 Initialization of Data	14
3.4 Auto-tuning	14
3.5 Error Display	15
3.6 Calibration	15
SECTION 4 SPECIFICATIONS	16

SECTION 1 INTRODUCTION

1.1 GENERAL DESCRIPTION

The OMEGA® CN380 Series Temperature and Process Controllers are compact and versatile instruments for temperature measurement and control. Models are available for thermocouple, RTD, voltage, or current inputs. Selection of sensor type, range, and °F or °C are made via easily accessible DIP switches within the case. The controllers feature "auto-tuning", i.e. the automatic selection of optimum PID values. Users have the option to bypass this auto-tuning feature and tune the PID values themselves.

The CN380 Series is available in four output models: 2.5A resistive load mechanical relay, solid state 15 VDC driver (for switching larger amperage SSR), 4 to 20 mA, and 0 to 10 VDC.

The alarm option offers two alarm points which can be set at any values within the input range. These can be set up as absolute values or as deviation values from the setpoint. To avoid false alarm indications, the alarms can be initially disabled until the input signal first enters the control band. Program features include "keylock", a means to prevent the user from altering program values. Advanced electronic features include a universal power supply which can accommodate voltage between 100-240 VAC 50/60 Hz, opto-isolation between inputs and outputs, and high noise immunity.

1.2 ORDERING INFORMATION

Model No.	Control Output
CN381-(*)	Mech. relay 2.5 A resistive at 240 Vac
CN382-(*)	Solid state relay 15 Vdc driver
CN383-(*)	4-20 mA proportional current
CN384-(*)	0-10 V proportional voltage

(*) Fill in input code TC = thermocouple, RTD = RTD 3 wire, mV = millivolts, V5 = voltage to 5 volts, mA = milliamperes

Alarm Output Option

Order Code	Description
-A	Dual alarms, 2.5 A resistance at 240 Vac, SPDT. (factory installed only).

Ordering Example: CN382-TC-A indicates a thermocouple input version with SSR driver and alarms.

User Selectable Input Ranges

Input	Type	°C	°F
Thermocouples Input Order Code: TC	T	-200 to 200	-300 to 400
	J*	0 to 400.0	0 to 750*
	E	-100 to 600	-150 to 1100
	K	0 to 400.0	0 to 750
	K	0 to 800	0 to 1450
	K	0 to 1200	0 to 2200
	N	0 to 1200	0 to 2200
	R	0 to 1600	0 to 2900
	S	0 to 1600	0 to 2900
	B	400 to 1800	750 to 3300
	C	0 to 2300	0 to 4200
	T (DIN)	-200 to 200	-300 to 400
J (DIN)	0 to 400	0 to 750	
100 Ω (3 wire RTD) Input Order Code = RTD	Pt 100 alpha = 0.00385* and alpha = 0.00392	-200 to 600	-300 to 1100
		-100.0 to 200.0	-150 to 390
		-100.0 to 300.0	-150 to 570
		0 to 50.0	0 to 120.0
		0 to 100.0	0 to 200.0
		0 to 200.0	0 to 400.0*
DC Millivolt Input Order Code: mV	mV	0 to 10 mV*	0 to 1 V
	V5	10 to 50 mV	1 to 5 V
DC Voltage Input Order Code: V5	-10 to +10mV	-1 to 1 V	
	0 to 20 mV	0 to 2 V	
DC Current Input Order Code: mA	4 to 20 mA*	0 to 20 mA	
	0 to 20 mA		

*Initial factory setting changeable by user.

For dc millivolt, dc voltage, and dc current inputs: user programmable scaling is selectable with a scaling range of -1999 to 7999 counts, a scaling span of 100 to 5000 counts, and a selectable decimal point position.

SECTION 2 INSTALLATION

2.1 UNPACKING

Remove the packing list and verify that all equipment has been received. If there are any questions about the shipment, please call OMEGA Customer Service Department.

Upon receipt of the shipment, inspect the container and equipment for any signs of damage. Take particular note of any evidence of rough handling in transit. Immediately report any damage to the shipping agent.

NOTE

The carrier will not honor any claims unless all shipping material is saved for their examination. After examining and removing contents, save packing material and carton in the event reshipment is necessary.

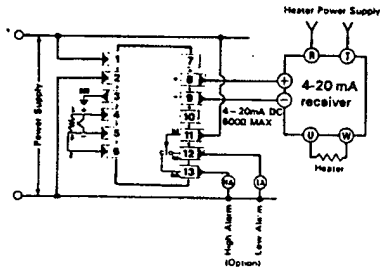

Figure 2-5. Current Output (CN-383) Wiring

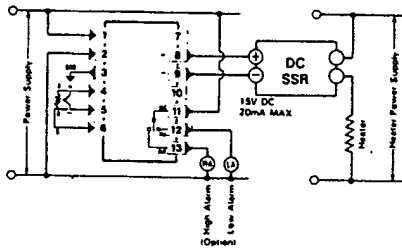

Figure 2-6. SSR Voltage (CN-382) Wiring

SECTION 3 OPERATION

3.1 CONTROLS AND INDICATORS

Refer to Figure 3-1 for location of various controls and indicators.

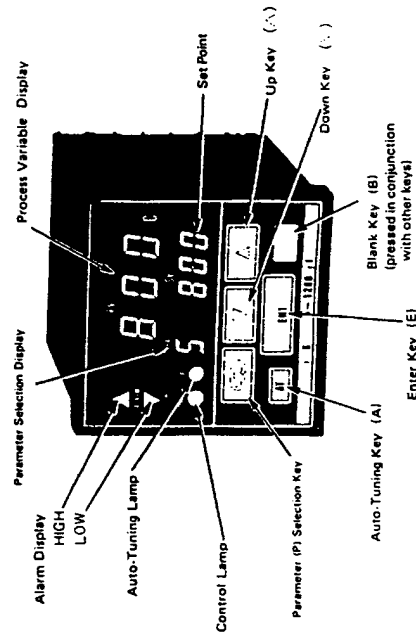

Figure 3-1. Controls and Indicators

3.2 DIP SWITCH SETTINGS

To access the DIP switches, remove the inner unit from its mounting case (turn off power and push the lock spring (a) located under the front panel). When replacing the inner unit, push it in slowly. (Refer to Figure 3-2).

SAFETY NOTE

Be sure to turn off the power supply before removing the inner unit from its mounting case.

Leave DIP switches H1, H7, H8, and L6 in UP position. These are used only for factory adjustment.

L1-L5 are the measuring range select switches for the thermocouple and RTD inputs and the input range select switches for voltage input. Set these switches by referring to Table 3-1 for input ranges selection. The DIP switches are very small and tight to prevent misoperation. Set these switches with a miniature screwdriver.

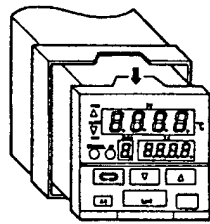

DIP Switches

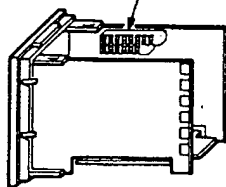
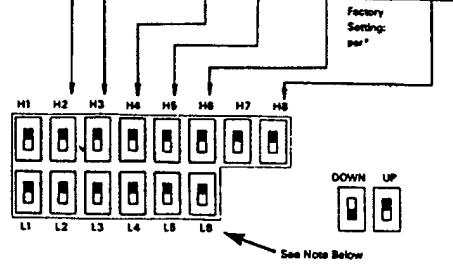

Figure 3-2. Dip Switches Location

Switch	Output Characteristic	RTD alpha	Temp. Units	Alarm	Alarm	Tuning
UP	Heating*	.00392	*C	ON*	Deviation Value*	AT
DOWN	Cooling	.00385*	*F*	OFF	Absolute Value	Manual



IMPORTANT
For 4-20mA or 0-10 Vdc output only, set the L6 DIP switch in the DOWN position.

Figure 3-3. DIP Switches Arrangement

3.2.1 Input Range for Thermocouple, RTD, Voltage, Millivolt, and Current Signals

Remove the inner unit from the mounting case, select the desired input range and set it with DIP switches L1-L5. Refer to Table 3-1.

NOTE

It is recommended that the input type and measuring range be written on the label on the rear panel of the instrument after completion of setting, each time it is changed.

TABLE 3-1
DIP SWITCHES SETTING

3.2.2 .00385/.00392 RTD Alpha Value (Position at time of shipment: alpha = .00385)

When changing to the alpha = .00392 mode, set DIP switch H3 to UP position.

When using the alpha = .00385 mode, set the DIP switch H3 to DOWN position.

**TABLE 3-1
DIP SWITCHES SETTING**

Input	DIP Switches L1, L2, L3, L4, L5	°C	°F
Thermocouple	T	-200 - 200	-300 - 400
	J	0 - 400.0	0 - 750
	E	-100 - 600	-150 - 1100
	K	0 - 400.0	0 - 750
	K	0 - 800	0 - 1450
	K	0 - 1200	0 - 2200
	N	0 - 1200	0 - 2200
	R	0 - 1600	0 - 2900
	S	0 - 1600	0 - 2900
	B	0 - 1800	0 - 3300
	C	0 - 2300	0 - 4200
	T DIN	-200 - 200	-300 - 400
R.T.D. (Pt100)		-200 - 600	-300 - 1100
		-100.0 - 200.0	-150 - 390
		-100.0 - 300.0	-150 - 570
		0 - 50.0	0 - 120.0
		0 - 100.0	0 - 200.0
		0 - 200.0	0 - 400.0
DC Voltage (V5) and Millivolt (mV)	-10 - 10mV 1 - 1 - 1V		
	0 - 10mV 10 - 1V		
	10 - 50mV 11 - 5V		
	0 - 20mV 10 - 2V		
	0 - 50mV 10 - 5V		
DC Current (mA)	*4-20 mA 0-20 mA		

For dc millivolt, dc voltage, and dc current inputs: user programmable scaling is selectable with a scaling range of -1999 to 7999 counts, a scaling span of 100 to 5000 counts, and selectable decimal point position.

3.2.3 Centigrade (°C) or Fahrenheit (°F) (Position at time of shipment: °C)

When using instrument in °C, set the DIP switch H4 to UP position.

When using the instrument in °F, set the DIP switch H4 to DOWN position.

3.2.4 Heating/Cooling Output Characteristics (Position at time of shipment: Heating)

When using the instrument in the heating characteristic mode, set the DIP switch H2 to UP position.

When using the instrument in the cooling mode, set the DIP switch H2 to DOWN position.

3.2.5 Absolute Value/Deviation Alarm Setting (Position at time of shipment: Deviation value)

Choose between absolute value and deviation value with the DIP switch H6 as shown.

Absolute value: DOWN position

Deviation value: UP position

NOTE: When absolute value/deviation value is changed, the alarm values must be re-entered.

3.2.6 Alarm ON at all times/Alarm OFF until input signal first enters control band (Position at time of shipment: ON)

Choose between ON/OFF with the DIP switch H5 as shown.

Always ON: UP position

Temporarily OFF: DOWN position

For the instrument supplied without alarm option, the alarm setting/alarm operating indicator lamp functions normally but the controller has no alarm control relay.

3.3 SETTING SELECTION USING FRONT KEYPAD

Set the parameters by referring to Figure 3-4, Parameter Block Diagram.

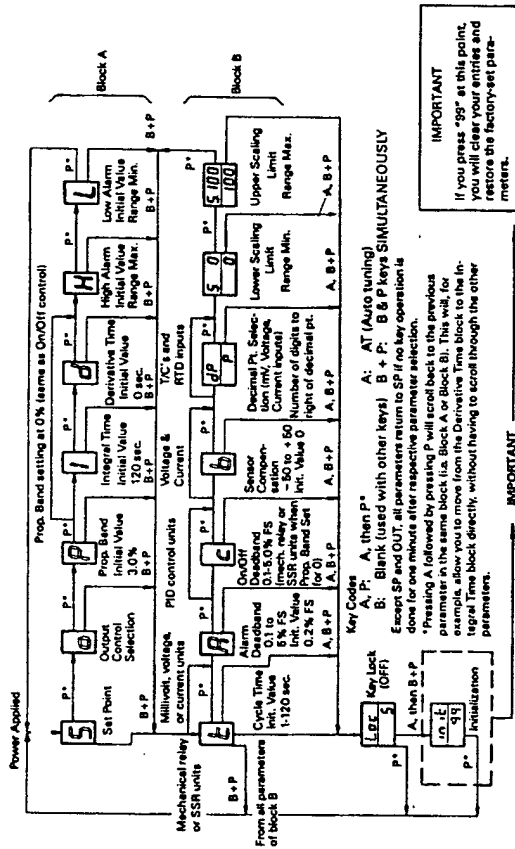

Figure 3-4. Parameter Block Diagram

The desired parameter may be called up by pressing the P (Parameter Selection), B (Blank), or A (Auto-Tune) keys. The required numerical values may be set by pressing the UP/DOWN key. During parameter setting, the decimal point in the lower right corner of the bottom display will flicker. Once the required value has been chosen, press the ENT key to set the value, at which time the decimal point will stop flickering.

To select a parameter in either Block A or Block B of the diagram, press the P (Parameter Selection) key. Each time P is pressed, the displayed parameter will move to the right one block on the parameter block diagram. For example, if the set value is displayed, pressing the P key will cause the Control Output to be displayed. To move back and forth between Block A and Block B, press the B (Blank) and P (Parameter Selection) keys simultaneously.

To proceed from Block B to the Key Lock Setting Parameter, first press the A (Auto-Tune) key, which will cause the AT lamp to light. Press the B (Blank) and P (Parameter Selection) keys simultaneously to enter the Key Lock Setting mode.

To proceed from the Key Lock Setting Parameter to the Initialization mode, press AT (Auto-Tune), then press the B (Blank) and P (Parameter Selection) keys simultaneously.

To return to Block A from either the Key Lock Setting Parameter or Initialization mode, press P.

It is not possible to change parameter settings in the Key Lock state or during Auto-tuning. However, the alarm setting can be set during Auto-tuning provided the key is unlocked.

3.3.1 Entering the Set Point (Initial value: 0)

For all inputs, set point must be within the upper and lower limits of the input range.

3.3.2 Output (Control Level) Monitor (P, I, D)

Select on/off control or proportional band, integral time, and deviation time.

3.3.3 Setting P (Proportional Band or ON/OFF)

Setting range: 0 to 200.0% (initial value: 3.0%) When setting at 0.0%, an ON/OFF control is available (for relay and SSR drive voltage outputs). In this case, when P = 0.0%, the upper limit alarm setting parameter (H) is given next.

3.3.4 Setting I (Integral time)

Setting range: 1 to 3600 seconds. (initial value: 120 sec.)

3.3.5 Setting D (Derivative time)

Setting range: 1 to 1200 seconds (initial set value: 0 seconds) Setting at 0 results in no derivation operation.

3.3.6 High/Low Alarm (Option)

Choose between Absolute and Deviation Value alarms with the internal DIP switch (H5). Setting range: 0.1 to 5.0% FS (initial value: 0.5% FS — common to upper and lower limits.) For instruments without an alarm relay, alarm setting and operation display will function, although there are no alarm relays to control outside circuits.

3.3.7 Proportional Cycle

This parameter is displayed for relay output and SSR drive voltage output types only. However, when using the ON/OFF control with the proportional band set at "0", this parameter is not displayed. Setting range: 1 to 120 seconds (initial value: 30 seconds).

3.3.8 Alarm Deadband (Option)

Setting range: 0.1 to 5.0% FS (initial set point: 0.5% FS) Common to upper and lower limits. For the instrument without an alarm, setting and operation display will function, but alarm output does not function.

3.3.9 Control Deadband (ON/OFF control)

This parameter is displayed when setting the proportional band at "0" for ON/OFF control in the case of relay and SSR drive voltage output types. Setting range: 0.1 to 5.0% FS (initial value: 0.2% FS)

3.3.10 Sensor Compensation

This parameter is only displayed for thermocouple and RTD input types. Compensation Range: -50.° to +50°C/°F (initial set value: 0)

3.3.11 Decimal Point Position for Voltage/Current Input

This parameter is not displayed for thermocouple and RTD input types. Setting range: Up to 3 digits to right of decimal point (initially set value: 1 digit to right of decimal point)

The decimal point position is according to the position of the character "P" in the display. If required, change the position with the up and down arrow keys.

3.3.12 Display for Voltage/Current Input

Setting range: Span of 100 to 5000 counts within range of -1999 to 7999 counts. Initially set low and high values are 0 and 100 respectively.

3.3.13 High/Low Alarm Limit for Thermocouple and RTD Inputs

Setting lower limit: Must be within range of Table 3-1. Initial factory set value: 0% of range.

Setting upper limit: Must be within range of Table 3-1. Initial factory set value: 100% of range.

3.3.14 Key Lock and Unlock

With the key lock state ON1, it is not possible to change the setting; change "MAN" to "AUTO", execute or stop the auto-tuning function.

With the key lock state ON2, the only functions available are setting of the setpoint and auto tuning functions. Other functions, such as changing alarm settings and changing "MAN" to "AUTO" cannot be performed.

To set the key lock state ON1, scroll to the key lock parameter and press the ENT key. "On1" is displayed for this key lock state.

To set the key lock state ON2, scroll to the key lock parameter and set "-5", using the UP/DOWN key, and press ENT. "On2" is displayed for this key lock state.

To unlock either key lock state (ON1 or ON2), set the parameter at "5" and press the ENT key. "OFF" is displayed for the key unlock condition.

3.3.15 Initialization of Data

This parameter is used to initialize all the settings and internal data set by the user. Call up the initialization parameter, set it to "99" and press the ENT key. Set point is displayed after several seconds and all the setting and data are initialized.

3.4 AUTO-TUNING

To execute auto-tuning, press the AT key to light up the AT LED, and press the ENT key making the AT LED flicker, which puts the instrument in auto-tuning mode. When auto-tuning is finished, the AT LED goes out.

After approximately 10 seconds with the AT key pressed and the AT LED on, the AT LED goes out automatically. To cancel the auto-tuning function before it completes its determination, press the AT key, followed by the ENT key. Pressing the AT key will cause the AT LED to flicker rapidly until ENT is pressed, at which time the AT LED will turn off.

If power fails during auto-tuning, the auto-tuning function is automatically released.

If 0% or 100% output continues for more than 4 hours and 30 minutes after auto-tuning is started, the auto-tuning is automatically released.

3.5 ERROR DISPLAY

When the PV (Process Variable) exceeds the measuring range, the following display is shown on the front.

PV < -10%FS	L.L. = -
110%FS < PV	H.H. = -

When the temperature sensor is abnormal, the following displays are shown respectively on the front.

Thermocouple Open Circuit	H.H. = -	* 1
---------------------------	----------	-----

Pt 100 Open Circuit of 1	H.H. = -	••	
Pt 100 Open Circuit of 2	E. = -	••	
Pt 100 Open Circuit of 3, 1-2, 1-3, 2-3, 1-2-3	L.L. = -	••	

Control output when the sensor is abnormal
 * 1. For heating (switch H2 set up): 0% or min. output
 For cooling (switch H2 set down): 100% or max. output
 * 2. 0% or min. output, regardless if switch H2 is set UP or DOWN. Both upper and lower limit alarms are energized. Output discontinues if auto-tuning is in process.

3.6 CALIBRATION

A CN-380 series controller automatically calibrates itself by way of its internal microprocessor.

SECTION 4 SPECIFICATIONS

DISPLAY

- Process Value (PV Display):** Digital LED (.4" high)
- Display Tolerance:** ±0.3% + 1 digit at 25°C ±5°C
- Display Resolution:** 1° or .1° per temp. range selected; up to 3 digits to right of decimal point for non-temperature input controllers, .3" high
- Set Point Display:** Digital LED (0.3152")
- Parameter Display:** Set point, proportional band, integral time, derivative time, High/Low alarm limit, Dead Band (On/Off mode), Auto tuning, High/Low alarm
- Status Displays:** Auto tuning, High/Low alarm, Control output

SETTING

- Setting Method:** Front membrane keypad
- Setting Selection:** Same as parameter display
- Set Key Selection:** Parameter check, UP, DOWN, AUTO TUNE, ENT, Mode key (16 modes)

INPUTS

- Thermocouples (User-selectable):** T, J, E, K, N, R, S, B, C, T-DIN, J-DIN
- External Resistance:** 100 ohm max.
- Input Impedance:** 500k ohms
- Burnout Circuit:** Standard feature (up scale)
- Cold Junction Temperature Compensation Range:** 5 to 45 °C
- RTD:** Pt,100Ω (alpha = .00385 or .00392)
- Current:** 1 mA
- Lead Wire Resistance:** 5 ohms max./lead

SPECIFICATIONS (Cont'd)

DC mV/Input Impedance: 0-10 mV, 10-50 mV, 0-20 mV, 0-50 mV, -10 to +10 mV/500k ohm Programmable range

DC Volt/Input Impedance: 0 to 1V, 1 to 5V, -1 to 1V, 0 to 2V, 0 to 5V/500K ohm Programmable range

DC Current/Receiving Impedance: 4-20 mA, 0-20 mA/250 ohm Programmable range

CONTROL OUTPUT

Control Mode: Auto-tuning PID with anti-reset windup plus manual tuning override

Proportional Band: 0 to 200% (On/Off mode at 0 setting) for relay and SSR drive units

Integral Time: 1 to 3600 seconds

Derivative Time: 0 to 1200 seconds (relay and SSR drive units)

Cycle Time: 1 to 120 seconds (relay and SSR drive units)

On/Off Deadband: 0.1 to 5% FS (relay and SSR drive units)

Control Output Characteristics: Heating and cooling, switch selectable

Control Outputs: Relay: 240 VAC 2.5A/resistive load, 1A/inductive load
Voltage: 0 to 10 VDC load current/2mA max.
Current: 4 to 20 mA DC load resistance 600Ω max.
SSR Drive Volts: 15 VDC, 20mA max.

Sampling Cycle: 0.25 second

Isolation: 500 Vac for 1 min. between input and internal circuit; 1000 Vac for 1 min. between internal circuit and output

SPECIFICATIONS (Cont'd)

ALARM

Alarm Mode: Two individually settable, SPDT relays. High/Low alarm selectable, deviation/absolute value selectable

Alarm Setting Ranges: Deviation: High alarm—Set point: 0 to +1999
Low alarm - Set point: 0 to -1999
Absolute Value: Within measuring range for both high and low alarms. High alarm > low alarm

Alarm Deadband: 0.1 to 5% FS

On/Off mode: Internally selectable (factory set: off)

Alarm Output/Rating: Mechanical relay/240 VAC, 2.5A/resistive load

DATA MEMORY: By non-volatile static RAM

OPERATING AMBIENT TEMPERATURE RANGE: 14 to 122°F
-10 to +50°C

OPERATING AMBIENT HUMIDITY RANGE: 90% RH max. (non-condensing)

POWER SUPPLY: 100 to 240 VAC ±10%, 50/60 Hz

POWER CONSUMPTION: Approximately 5 VA

INSULATION RESISTANCE: 20 MΩ at 500 VDC, max. between input terminal and power supply terminal; 20MΩ at 500 VDC, max. between power supply terminal and ground

DIELECTRIC STRENGTH: One minute at 500 VAC between input terminal and power supply terminal; One minute at 1000 VAC between power supply terminal and ground

SPECIFICATIONS (Cont'd)

EXTERNAL DIMENSIONS:	2.84''H x 2.84''W x 4.06''D (72 x 72 x 103mm) Depth behind panel 3.546'' (90mm)
PANEL CUTOUT DIMENSIONS:	2.7'' square (68 mm square)
WEIGHT:	Approximately .68 lbs (1.3kg)

WARRANTY

OMEGA warrants this unit to be free of defects in materials and workmanship and to give satisfactory service for a period of 13 months from date of purchase. OMEGA Warranty adds an additional one (1) month grace period to the normal one (1) year product warranty to cover handling and shipping time. This ensures that OMEGA's customers receive maximum coverage on each product. If the unit should malfunction, it must be returned to the factory for evaluation. OMEGA's Customer Service Department will issue an Authorized Return (AR) number immediately upon phone or written request. Upon examination by OMEGA, if the unit is found to be defective it will be repaired or replaced at no charge. However, this WARRANTY is VOID if the unit shows evidence of having been tampered with or shows evidence of being damaged as a result of excessive corrosion or current, heat, moisture or vibration; improper specification; misapplication; misuse or other operating conditions outside of OMEGA's control. Components which wear or which are damaged by misuse are not warranted. These include contact points, fuses, and traces.

OMEGA is glad to offer suggestions on the use of its various products. Nevertheless, OMEGA only warrants that the parts manufactured by it will be as specified and free of defects.

OMEGA MAKES NO OTHER WARRANTIES OR REPRESENTATIONS OF ANY KIND WHATSOEVER, EXPRESSED OR IMPLIED, EXCEPT THAT OF TITLE AND ALL IMPLIED WARRANTIES INCLUDING ANY WARRANTY OF MERCHANTABILITY AND FITNESS FOR A PARTICULAR PURPOSE ARE HEREBY DISCLAIMED.

LIMITATION OF LIABILITY: The remedies of purchaser set forth herein are exclusive and the total liability of OMEGA with respect to this order, whether based on contract, warranty, negligence, indemnification, strict liability or otherwise, shall not exceed the purchase price of the component upon which liability is based. In no event shall OMEGA be liable for consequential, incidental or special damages.

Every precaution for accuracy has been taken in the preparation of this manual however, OMEGA ENGINEERING, INC. neither assumes responsibility for any omissions or errors, that may appear nor assumes liability for any damages that result from the use of the products in accordance with the information contained in the manual.

SPECIAL CONDITION: Should this equipment be used in or with any nuclear installation or activity, purchaser will indemnify OMEGA and hold OMEGA harmless from any liability or damage whatsoever arising out of the use of the equipment in such a manner.

RETURN REQUESTS / INQUIRIES

Direct all warranty and repair requests/inquiries to the OMEGA ENGINEERING Customer Service Department. BEFORE RETURNING ANY PRODUCT(S) TO OMEGA, PURCHASER MUST OBTAIN AN AUTHORIZED RETURN (AR) NUMBER FROM OMEGA'S CUSTOMER SERVICE DEPARTMENT IN ORDER TO AVOID PROCESSING DELAYS. The assigned AR number should then be marked on the outside of the return package and on any correspondence.

FOR WARRANTY RETURNS, please have the following information available BEFORE contacting OMEGA:

1. P.O. number under which the product was PURCHASED,
2. Model and serial number of the product under warranty, and
3. Repair instructions and/or specific problems relative to the product.

FOR NON-WARRANTY REPAIRS OR CALIBRATION: consult OMEGA for current repair/calibration charges. Have the following information available BEFORE contacting OMEGA:

1. P.O. number to cover the COST of the repair/calibration,
2. Model and serial number of product, and
3. Repair instructions and/or specific problems relative to the product.

OMEGA's policy is to make running changes, not model changes, whenever an improvement is possible. This affords our customers the latest in technology and engineering. OMEGA is a registered trademark of OMEGA ENGINEERING, INC.

© Copyright 1995 OMEGA ENGINEERING, INC. All rights reserved. This documentation may not be copied, photocopied, reproduced, translated, or reduced to any electronic medium or machine-readable form, in whole or in part, without prior written consent of OMEGA ENGINEERING, INC.

CSI GLP SOP
No. MTH 13-1

CAMBRIDGE SCIENTIFIC, INC.
Good Laboratory Practice Standard Operating Procedure

Date: 17 January, 2003

GRINDING, PACKAGING, AND LABELING OF EXTRUDED RODS

Written By: _____ Reviewed By: _____
Signature Date Signature Date

Responsibility of:
Lab supervisor or someone familiar with technique

Signature Date

Lab Director

Signature Date

SUMMARY:

Methods are described for cutting rods to lengths designed to deliver specific doses. Rods are nominally 1.4 mm diameter containing 25% by weight of hydromorphone hydrochloride in a PLGA-50:50 excipient. Protocols for packaging and labeling are also described.

KEY WORDS: Extruded rods, microparticles, grinding, packaging, labeling

EQUIPMENT:

Single edged razor blades, latex gloves, polymer backed bench paper (Benchkote, Fisher 12-007 -180 to -188), serum vials, closures, crimper, decapper (see accompanying text).

REFERENCE:

SOP EQP 11-1

GRINDING, PACKAGING AND LABELING OF EXTRUDED RODS

The following is a continuation of EQP 11-1 but deals with the packaging and labeling of the produced microparticles. The inclusion of this material at this point follows logically from the extrusion operation in that grinding, packaging, and labeling must be done AS SOON AS POSSIBLE after the extrusion.

Prepare in advance an empty work space covered with clean, unused polymer backed bench paper (such as Kaydry Lab Table Soaker, VWR Cat. No. 52857-120 or Fisher Bench Protectors, Cat. No.12-007-180-187). Polymer backing should be face up.

Containers for ground microparticles should be 5 ml capacity amber serum vials 40 mm in length. Have these ready along with closures and crimper. Appropriate vials, closures and crimper are manufactured by Wheaton and are obtainable from VWR or Fisher.

Cambridge Scientific, Inc.
180 Fawcett Street
Cambridge, MA 02138

	Fisher	VWR
5 ml Serum Vial, 40 mm ht.	06-446H	66013-120
Closures*	06-406-14	66010-812
Crimper	10-319-490	26676-596
Decapper	06-451-132	10-319-490

* Teflon based red rubber line with aluminum crimp.

Have available on the bench the serum vials, closures, and crimper.

Grind extruded rod according to EQP 11-1 to generated sieved microparticles. Before dividing microparticles into individual doses, label each serum vial with Batch Number, Extrusion Control Number, and follow this with a -1, -2, etc. to indicate the individual dose.

Divide microparticles into 50 mg doses and seal in labeled serum vial.

RESERVING SAMPLES

The following is a further continuation of the above and describes requirements for reserving microparticles for analysis. The requirement is to retain 10% of the individual doses. These shall be a representative sampling taken as follows: Arrange all vials from each extrusion in groups. At random, take two vials from each group. Reserve these for microbiological assay and for stability tests.

CSI SOP
No. MTH 14-1CAMBRIDGE SCIENTIFIC, INC.
Good Laboratory Practice Standard Operating Procedure

Date: 17 January, 2003

ANALYSIS OF RESIDUAL ACETIC ACID IN EXTRUDED RODS BY
GAS CHROMATOGRAPHIC HEAD SPACE EXTRACTIONWritten By: _____ Reviewed By: _____
Signature Date Signature DateResponsibility of:
Lab supervisor or someone
familiar with technique_____
Signature Date

Lab Director

Signature Date**SUMMARY:**

The technique of head space analysis is briefly described with application to analysis of residual acetic acid in polymer matrices.

KEY WORDS: Residual acetic acid, head space analysis, gas chromatography**EQUIPMENT:**

Gas chromatograph equipped with Head Space Sampler HS-6 (Perkin Elmer) or Automatic Headspace Sampler HS-101 (Perkin - Elmer) or equivalent and appropriate vials etc. The following may be used(?).

- 4 ml clear silanized 15x45 mm screw thread vials (Supelco 2-7114 or 2-7270)
- White PTFE/white silicone septa (Supelco 2-7356 or 2-7369)
- Polypropylene cap with PTFE/silicone liner open top closure (Supelco 2-7018)
- Capper, crimper,

REFERENCE:

LS Ettre, B Kolb, and SG Hurt, "Techniques of Headspace Gas Chromatography", American Laboratory, Oct. 1983, 76-83

METHOD:

1. Mass approximately 100 mg of microparticles into vial and seal.
2. Connect needle from carrier gas supply to vial as shown in Figure A.
3. Thermostat the vial at 125°C (as in Fig. A) for 10 minutes exactly. This brings the sample to a state approaching equilibrium which is reproducible because of the constancy of the equilibration time.
4. Introduce carrier gas as shown in Fig. B. This will pressurize the vial until pressure reaches the inlet pressure. This step is to be precisely timed at 30 seconds.
5. Temporarily cut off the carrier gas supply to the vial as shown in Fig. C. in order to transmit a controlled aliquot volume from the head space of the vial to the column. This operation is also precisely controlled to 30 seconds
6. Resume the carrier gas supply to the column as shown in Figure D for analysis.
7. After the analysis is complete, release the internal pressure in the vial to the atmosphere. Leave the needle in place the vial but make the disconnection between the needle and the valve.
8. Repeat this analysis three more times on the same sample.

Cambridge Scientific, Inc.
180 Fawcett Street
Cambridge, MA 02138

8. Repeat this analysis three more times on the same sample.

STANDARDS

Head space analysis requires standards. Use microvolume syringe with a 0.5 μ l capacity (Supelco Model 0.5 BNR-5 or 0.5 BR-70) for injecting gl HAc into vial. Inject 0.2 μ l of gl HAc into vial and do MHE (Multiple Headspace Extraction) four times to establish standard curve.

CALCULATIONS

The decrease in peak areas is a logarithmic function given by

$$\ln A_i = -k(n-1) + \ln A_1$$

where

A_1 = area of first analysis

A_i = area of i -th analysis

n = the number of the extraction steps

Plot A_i versus n . The slope is k . The total area (proportional to the total residual solvent is given by

$$\sum A_i = \frac{A_1}{1 - e^{-k}}$$

Note: if $n = 2$

$$\sum A = \frac{A_1^2}{A_1 - A_2}$$

ACCEPTANCE CRITERIA

Maximum concentrating glHAc in extruded rod shall not exceed 1000 ppm (ims/gram)

ACETIC ACID PROPERTIES

Vapor pressure-temperature

mm	°C	mm	°C
1	-17.2 (s)	100	63.0
10	+17.5	400	99.0
40	43.0	760	118.1

$$bp = 118^\circ C$$

$$mp = 16.7^\circ C$$

DENSITY

$$P(16.67^\circ C) = 1.053(\text{liquid})$$

$$P(16.60^\circ C) = 1.266(\text{solid})$$

NOTE

Cambridge Scientific, Inc.

180 Fawcett Street

Cambridge, MA 02138

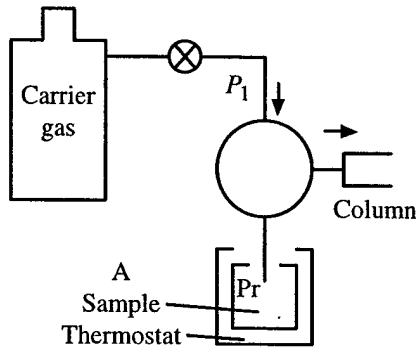

A
Equilibration
 $P_1 > P_v$

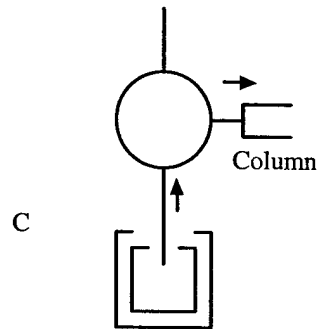

C
Transfer of aliquot sample to column

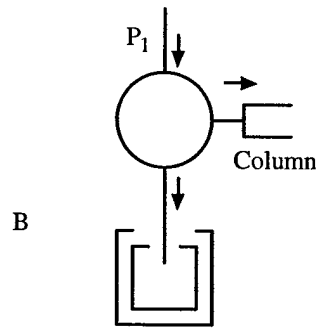

B
Pressurization
 $P_1 \rightarrow P_v$

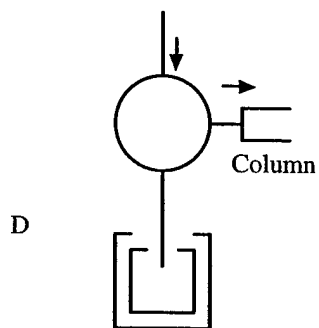

D
Analysis of aliquot sample