

# REPORT DOCUMENTATION PAGE

*Form Approved*  
**OMB No. 0704-0188**

Public reporting burden for this collection of information is estimated to average 1 hour per response, including the time for reviewing instructions, searching existing data sources, gathering and maintaining the data needed, and completing and reviewing this collection of information. Send comments regarding this burden estimate or any other aspect of this collection of information, including suggestions for reducing this burden to Department of Defense, Washington Headquarters Services, Directorate for Information Operations and Reports (0704-0188), 1215 Jefferson Davis Highway, Suite 1204, Arlington, VA 22202-4302. Respondents should be aware that notwithstanding any other provision of law, no person shall be subject to any penalty for failing to comply with a collection of information if it does not display a currently valid OMB control number. **PLEASE DO NOT RETURN YOUR FORM TO THE ABOVE ADDRESS.**

<b>1. REPORT DATE (DD-MM-YYYY)</b> 29-10-2002		<b>2. REPORT TYPE</b> Technical Paper		<b>3. DATES COVERED (From - To)</b> 01-01-2002 to 25-10-2002	
<b>4. TITLE AND SUBTITLE</b>  Sealed Window Glazing System for Chemical-Biological Protected Space Applications				<b>5a. CONTRACT NUMBER</b> 8637-98-C-6001	
				<b>5b. GRANT NUMBER</b>	
				<b>5c. PROGRAM ELEMENT NUMBER</b> 6112	
<b>6. AUTHOR(S)</b>  Maj. Dov Dover, P.E. (IAF), Dr. Mark Anderson, P.E., and Mr. Richard N. Vickers				<b>5d. PROJECT NUMBER</b> 4915	
				<b>5e. TASK NUMBER</b> D11A	
				<b>5f. WORK UNIT NUMBER</b>	
<b>7. PERFORMING ORGANIZATION NAME(S) AND ADDRESS(ES)</b>  Israeli Air Force (on assignment to AFRL/MLQD)  Applied Research Associates, Inc. Engineering and Science Division P.O. Box 40128, Tyndall AFB, FL 32403  Air Force Research Laboratory Airbase Technologies Division, Deployed Base Systems Branch 139 Barnes Drive, Suite 2, Tyndall AFB, FL 32403				<b>8. PERFORMING ORGANIZATION REPORT NUMBER</b>	
<b>9. SPONSORING / MONITORING AGENCY NAME(S) AND ADDRESS(ES)</b>  Air Force Research Laboratory Airbase Technologies Division, Deployed Base Systems Branch 139 Barnes Drive, Suite 2, Tyndall AFB, FL 32403				<b>10. SPONSOR/MONITOR'S ACRONYM(S)</b> AFRL/MLQD	
				<b>11. SPONSOR/MONITOR'S REPORT NUMBER(S)</b> AFRL-ML-TY-TP-2002-4625	
<b>12. DISTRIBUTION / AVAILABILITY STATEMENT</b> (PA Case Number 02-271) Approved for public release, distribution unlimited. Paper is available in <i>Proceedings</i> , NBC Defense Collective Protection Conference (COLPRO 02), Orlando, Florida, October, 2002.					
<b>13. SUPPLEMENTARY NOTES</b>					
<b>14. ABSTRACT</b> Recent world events have drawn attention to threats that extend beyond deployed forces, to the civilian population. In the recent Gulf War, several specific threats were highlighted for both US military forces and Israeli civilians. The most obvious threat to civilians in that conflict was explosive. Less obvious, but even more potentially dangerous, was the threat of chem-bio weapons of mass destruction. The key in "protective design" is to define the weak points in a structure and reduce the threat at those points. The paper discusses early pioneering work on blast-resistant windows, at the Air Force Research Laboratory (AFRL/MLQD), that dealt with the use of applied polymer membranes to combat the combined threat of blast and chem-bio attacks. The paper discusses the evolution of "membrane" windows, right up to the present, where a combination of rigid and flexible components, membranes, anchoring techniques, and pressure relief ports are used to create a window which can withstand the pressure expected from a large blast and afterwards retain membrane integrity sufficient to resist a subsequent chem-bio attack. Specific improvements which have increased the survivability of the window are discussed, as are improvements currently being tested which should allow these windows to be expanded to "store-front" size without a degradation in the protection.					
<b>15. SUBJECT TERMS</b> Blast Resistant, Chem-Bio, Windows, Membrane Action, Damping Chamber, Protective Design, Protected Space, Combined Threat					
<b>16. SECURITY CLASSIFICATION OF:</b>			<b>17. LIMITATION OF ABSTRACT</b>  UU	<b>18. NUMBER OF PAGES</b>  17	<b>19a. NAME OF RESPONSIBLE PERSON</b> Mark Anderson
<b>a. REPORT</b> U	<b>b. ABSTRACT</b> U	<b>c. THIS PAGE</b> U			<b>19b. TELEPHONE NUMBER (include area code)</b> (850) 283-3730

# Sealed Window Glazing System for Chemical Biological Protected Space Applications

Maj. Dov Dover, P.E.,<sup>1</sup> Mark Anderson, Ph.D., P.E.,<sup>2</sup> & Richard N. Vickers<sup>3</sup>

## ABSTRACT

Recent world events have drawn attention to threats that extend beyond deployed forces, to the civilian population. A protective design approach for new structures, as well as retrofitted existing structures, has become increasingly palatable, despite the increased costs, because of chemical-biological threats that were once considered "remote." The key in "protective design" is to define the weakest points in a structure and then reduce the threat at those points.

In the recent Gulf War, several specific threats were highlighted for both US military forces and Israeli civilians. The most obvious threat to civilians in that conflict was explosive, as about forty SCUD missiles were launched into civilian areas of Israel. Less obvious, but even more potentially dangerous, was the threat of chemical and biological weapons of mass destruction.

Recognizing the weakness of entry points to chem-bio contamination, many Israeli civilians used plastic sheeting on the interior side of their windows during periods of increased threat. When properly sealed, this provided a barrier that was considered both adequate and cost-effective. Still, this method did not provide a solution for a combined threat, i.e., both explosion and chem-bio intrusion. While this paper primarily addresses the chem-bio issue for windows, the solution presented herein is capable of withstanding the combined threat.

The paper discusses early pioneering work at the Air Force Research Laboratory (AFRL/MLQD) that dealt with the use of applied polymer membranes to combat the combined threat. The paper discusses the evolution of "membrane" windows, right up to the present, where a combination of rigid and flexible components, membranes, anchoring techniques, and pressure relief ports are used to create a window which can withstand the pressure expected from a large blast (e.g., a car bomb) and afterwards retain membrane integrity sufficient to resist a subsequent chem-bio attack.

Specific improvements which have increased the survivability of the window are discussed, as are improvements currently being tested which should allow these windows to be expanded to "store-front" size without a degradation in the protection. The final outcome of this research will be a window which will survive a chem-bio attack, even when preceded by an explosive attack, and which is reasonably cost-effective, even for retrofitting.

---

<sup>1</sup> Israeli Air Force; on assignment to AFRL/MLQD (Air Force Research Laboratory, Materials and Manufacturing Directorate, Airbase Technologies Division, Deployed Base Systems Branch), 139 Barnes Dr., Ste. 2, Tyndall Air Force Base, Florida 32403; phone (850) 283-3718; FAX (850) 283-3722; [Dover@gulf.net](mailto:Dover@gulf.net)

<sup>2</sup> AFRL / MLQD; phone (850) 283-3730, DSN 523; FAX (850) 283-3722; DSN 523; [Mark.Anderson@tyndall.af.mil](mailto:Mark.Anderson@tyndall.af.mil)

<sup>3</sup> Branch Chief, AFRL / MLQD; phone (850) 283-3707, DSN 523; FAX (850) 283-3722, DSN 523; [Richard.Vickers@tyndall.af.mil](mailto:Richard.Vickers@tyndall.af.mil)

20040130 123

## BACKGROUND

### Basic Concepts

**Window operation.** The basic configuration uses a "double panel" window. When the blast wave impacts the front panel, the incident pressure bends the panel inward. The use of an elastic anchoring system, coupled with the elasticity/plasticity of judiciously placed film(s), allows the window to bow (i.e., acting like a membrane). Additionally, the air trapped between the panels is compressed and vented, thereby reducing the pressure transferred to the back panel. The design challenge is to make the two panels oscillate at a controlled maximum amplitude, and then having an exponential decay in the oscillations, to a complete stop.

**Panels or panes?** The definitions of the terms "panel" and "pane" may vary, according to the reference source. However, for purposes of this paper, these terms have specific meanings. They are herein distinguished as follows: (1) the term "pane" refers to a single piece of homogeneous material, either glass or plexiglass; and (2) the term "panel" refers to either the front or back unit of the "double panel" windows (panel may refer to a single pane, as for the back pane in some of the 1<sup>st</sup> generation windows; but usually refers to a laminate structure consisting of at least one pane of glass and either one thick clear polymer film, or two thin clear polymer films).

**The membrane concept.** The "membrane concept" is a technique well known to designers of blast-resistive facilities. Conceptually, the membrane concept replaces an otherwise rigid structural element with a structural element of similar structural capability, but which (either in lieu of, or in addition to) incorporates an elastic membrane, or the equivalent, to improve the resistance to blast pressures (i.e., high stress, transient loadings). The layman has an intuitive understanding of the membrane concept from observations of airplanes in flight. Wind loads on airplanes also cause short duration, high stress loadings, which are resisted by the flexible metallic "skin" of the aircraft.

The combined threat imposes two major engineering demands on window designs: (1) elastic behavior of the glazing element to resist blast pressures; and (2) complete seal of the window opening to prevent chem-bio contamination. Previous solutions to the separate threats of blast and chem-bio attack have treated these threats as isolated problems, and, in general, a priority was given to blast resistance. But, in the new "terror threat" age, separate solutions are not enough. The membrane concept was incorporated into research on windows capable of resisting the combined threat, because it has the potential of simultaneously resisting both threats, while still allowing visual access (obviously, other solutions come to mind if visual access is not an issue; in fact, if points of entry are the weak link in preventing a combined attack, one obvious solution is to simply eliminate all points of entry – however, that solution leaves much to be desired, particularly in regards to a civilian population).

**The damping chamber concept.** The "damping chamber concept," as applied to the combined threat window, uses a vented air gap between the front and back panels of a "double panel" window to improve blast resistance. The vented air gap acts as a damping chamber which "cushions" the blast wave. The damping effect is sometimes easier to understand by considering the opposite, or unvented, case. If a double panel window is not vented, the front panel tends to deform inward under the incident pressure. As the front panel moves inward, the air trapped within the window tends to compress, thereby causing a transference of the pressure to the back panel. Conversely, when the air gap is properly vented, the chamber acts like a cushion, which can improve the performance of both the front and back panel. Obviously, pushing air out the vents reduces the internal pressure, which, in turn, reduces the pressure on the back panel.

Perhaps less obvious, this "cushioning" also helps the front panel. This effect is similar to the damping of highway crash barrels used to protect automobiles in collisions with highway barriers (e.g., abutments), or the damping of an air bag used by stunt men to fall from great heights without serious injury.

**The film tail anchoring concept.** The "film tail anchoring concept" uses an extended edge, or "tail," on the film to provide additional gripping between the frame and panel. By using a rubber anchoring system and a film tail, the problems of anchoring experienced in the First Generation windows (see the subsequent section titled "First Generation Windows (Warsaw Threat)") were avoided in the Second Generation windows, because the Second Generation windows did not depend on the relatively brittle glass panels for the primary gripping force.

**The perforated flange concept.** The "perforated flange" concept makes use of metal plates around the back (i.e., interior) edge of the window assembly. These plates, or flanges, are bonded to the wall using a sprayed polymer (the same sprayed polymer used to retrofit the wall for blast resistance<sup>4</sup>). By having perforations in the flanges, there is a mechanical connection (as well as an adhesion) between the wall, the polymer, and the window flange. The combination of a solid flange in front (connected with bolts) and a perforated flange in back (connected with sprayed polymer) makes the window and wall act as a unit. In particular, the key result is that the window and wall will oscillate at the same frequency (the entire window frame can break out if they are allowed to oscillate at different frequencies).

## Historical Background

In the 1990s, concerns about a "combined threat" became a significant issue for the Air Force. The "combined threat" is the use of an explosive pressure wave to expose the inside of a structure to chemical or biological attack. In the past, research on blast-proof structures, including windows, had concentrated on eliminating such problems as shrapnel (i.e., explosive fragmentations), direct concussion, and indirect concussion effects (e.g., flying books or overturned furniture).

A first generation of combined threat windows went through several design iterations under threat conditions generally referred to as the "Warsaw threat." However, with the fall of the Berlin Wall and the breakup of the Soviet Union, there was a de-emphasis on research to support NATO-type structures. Recently, however, there has been renewed interest in the combined threat. For example, the use of aircraft as bombs by *al-Qaida*, followed soon after by the use of Anthrax by unknown terrorists (not to mention the possibility that West Nile virus was intentionally introduced) has implicitly increased the awareness of the combined threat in the civilian population of America. In addition, the international community, and Israel in particular, was made aware of the combined threat by the actions of Iraq in the Gulf War era. That is, during the Gulf War, Iraq used SCUD missiles in attacks on civilian targets (mainly in Israel); and soon after the Gulf War, Iraq used chemical weapons on its own dissidents. This willingness of a single country, or terrorist groups (known or unknown), to use both explosive and chem-bio agents has greatly increased the interest in developing retrofit techniques for resistance to the combined threat.

The new "terror threat" has led AFRL to develop a second generation of retrofit windows to resist the combined threat from terrorist organizations, rogue nations, and / or person or persons unknown. Using the research from the early 1990s as a starting point, several dramatic improvements were implemented almost immediately. It is these second generation windows

---

<sup>4</sup> This is a Patent pending method developed by AFRL at Tyndall Air Force Base, Florida.

which are the main focus of this paper. However, in the interest of historical perspective, a step-by-step description of the various design stages, including the results and “lessons learned” from explosive tests, are included in this Background section for each step of the first generation program.

### First Generation Windows (Warsaw Threat)

**Design 1.** A schematic of Design 1 is shown in Figure 1. From the start, the membrane concept and the damping chamber concept were incorporated into the design process. To implement the membrane concept, clear polymer film was used to provide additional “elasticity” (in the case of glass windows, improved “elasticity” usually translates into increased tensile strength). To implement the damping chamber concept, air vent holes were cut into the rigid frame, between the two glass panels.

Design 1 used a “panel” which was a laminate structure consisting of two tempered glass panes, with a relatively thick clear polymer film<sup>5</sup> sandwiched between. The laminate design was intended to improve the panel’s tensile strength compared to an equivalent thickness single glass pane. Initial calculations indicated that, for a single film, placing the film in the center would provide the best overall improvement to the panel’s behavior, since it would be subjected to both the positive phase of the incident pressure (which tends to cause inward bending), and the negative phase (which tends to cause “snap back,” or even outward bending). In addition, as a practical matter, the two glass panels which sandwiched the film provided abrasion protection for the film. In addition to the front laminate panel, there was a tempered glass panel in the back of the assembly, forming the damping chamber, and additionally to serve as a “catcher” for any loose glass shards which might come backwards from the front panel. The inner frame was made of steel and contained vent holes whose size was based on estimates of the maximum volume of air which would be displaced during the time period of the initial impulse. The laminate panel and the back panel were held in place with standard automobile windshield mastic.

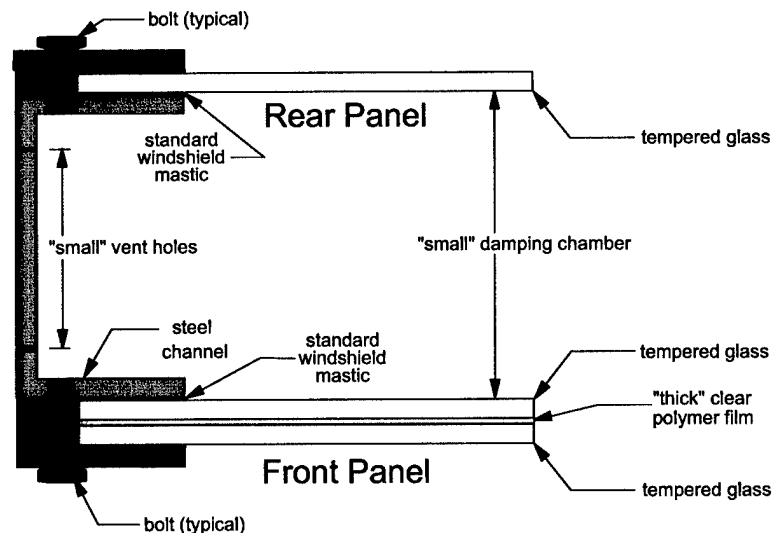

Figure 1. First Generation Window, Design 1.

<sup>5</sup> The clear polymer films described in this paper are premanufactured “plastic sheets,” and should not be confused with the spray-on polymers used for retrofit blast protection of structures.

**Blast Testing of Design 1 Prototype.** The Design 1 prototype window was installed in a mobile office building which had been scheduled for explosive testing. After installation, the structure, including the window, was subjected to the design blast at the design standoff distance. The window had no blast-related damage, although the front panel had minor damage caused by fragmentation (i.e., small rocks thrown up by the explosion). The “ground zero” configuration was subsequently redesigned to virtually eliminate this type of fragmentation, so that the effects of the blast wave was isolated in all subsequent tests.

Having exceeded the initial design criteria, the Design 1 prototype window previously tested was repaired, re-installed in the mobile office building, and subsequently tested with the same amount of explosive, but at approximately  $\frac{2}{3}$  of the design standoff distance. In this case, the outer panel “marbleized” (i.e., the glass panels were broken into small bits, giving the glass a texture resembling marble), and the inner panel was completely blown out. The results of this test were difficult to analyze due to the complete failure of the back glass panel.

**Design 2.** A schematic of Design 2 is shown in Figure 2. This second design replaced the tempered glass back panel with a panel of plexiglass. Initial calculations indicated that the increased flexibility of the plexiglass would make it more likely to withstand the initial pressure wave, so that it could then “catch” all of the loose glass shards from the marbleized front panel. The remaining parts of the Design 2 prototype window were constructed as previously discussed (for more details, see previous discussion in section titled “Design 1”).

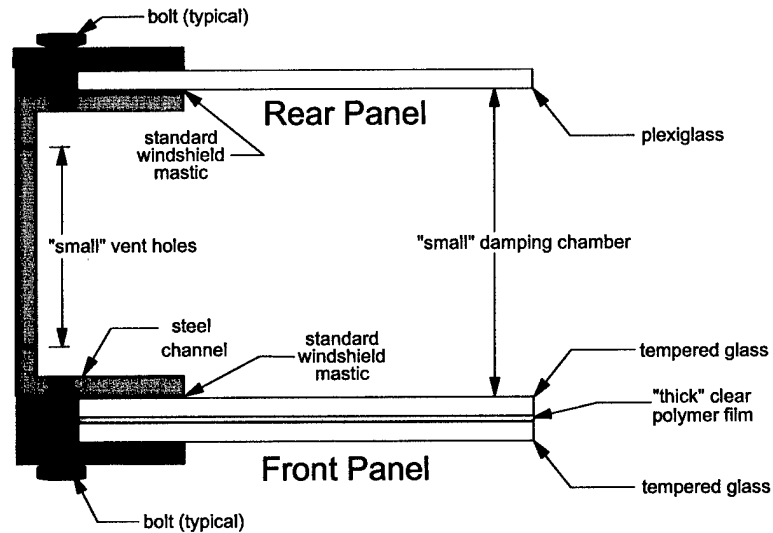

Figure 2. First Generation Window, Design 2.

**Blast Testing of Design 2 Prototype.** The Design 2 prototype window was installed in a mobile office building, and subjected to the design blast at the design standoff distance. As expected, in the absence of fragmentation from the blast, the pressure wave caused absolutely no damage to the Design 2 window.

The Design 2 prototype window was then subjected to the design blast at the reduced standoff distance (approximately  $\frac{2}{3}$  of the design standoff). Under the increased blast pressure, the outer panel “marbleized” (as it did for the Design 1 prototype). However, in the case of the Design 2 prototype window, the back panel held all of the glass shards (i.e., no catastrophic

failure of the back panel). Even though no glass shards passed through the plexiglass panel, there was some diagonal cracking in the plexiglass panel, which indicated that there was an excess of pressure in the "chamber" between the two window panels. But, more importantly, the "caught" glass shards indicated a significant design flaw in both of the initial designs. The front panel depended on friction between the windshield mastic and the two glass panes to stay in place. But, as the front panel marbleized, the frictional contact was lost, and the panel sides gave way. That is, the clear polymer film between the front glass panes remained intact, but was pulled away from the sides of the frame as the glass surrounding it shattered.

**Design 3.** A schematic of Design 3 is shown in Figure 3. The aspect ratio of the window was altered in an attempt to reduce the transferred pressure on the back glass, and a polymer spray was used to decrease the loss of friction on the front panel (previously described in the section titled "Explosive Testing of Design 2 Prototype"). In addition, the interior damping chamber was increased in thickness, and the vent holes were increased in diameter.

Since previous testing seemed to indicate that the positive phase of the incident blast wave provided the controlling pressure, the glass pane in front of the clear polymer film was omitted in the Design 3 prototype window. That is, there was a single glass pane in the front panel, with the clear polymer film on the front of the panel (i.e., facing the blast). The other materials were the same as previously used. After installation, the front panel edges were sprayed with a commercial elastomer protective coating to provide additional strength at the edges.

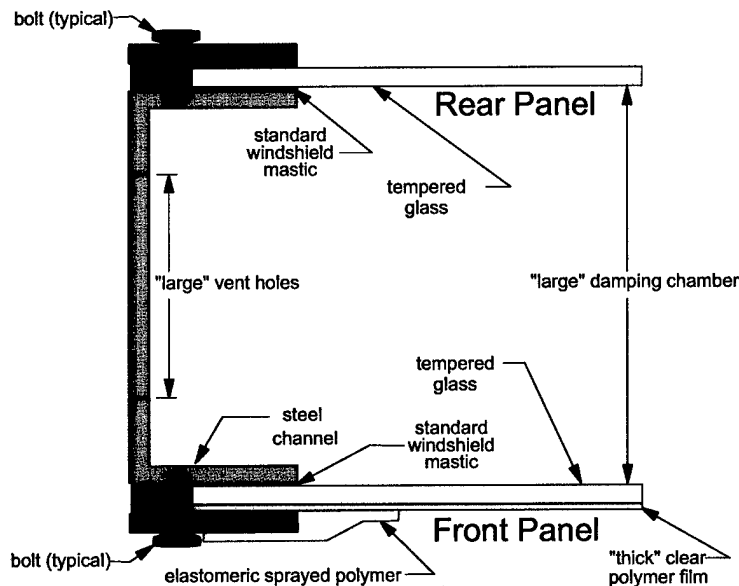

Figure 3. First Generation Window, Design 3.

**Blast Testing of the Design 3 Prototype.** Based on the success of the Designs 1 and 2 prototype windows, the original design standoff distance was deemed unnecessary high, and subsequent testing used only the reduced standoff distance (i.e.,  $\frac{2}{3}$  of the original design standoff distance). Therefore, the Design 3 prototype window was subjected to the design blast only at the new standoff distance. In this case, three sides of the window held tightly (i.e., no "pull-out"), but the top edge failed in a manner similar to the failure of the previous designs (i.e.,

“pull-out”). On close examination, it was determined that the protective polymer layer had an abrupt edge along the top of the window, due to dripping of the polymer which interfered with the spraying process. That is, the three edges where the spray polymer had a good bond with the polymer film did not have pull-out, but the edge where the polymer spray did not bond well with the film did have pull-out. Although only one side of the front panel pulled out, there was enough pressure transferred to the back panel to cause complete “blow out.”

**Design 4.** Based on previous results, it became clear that reinforcement of the back “catcher” panel was desirable. Also, although actual testing seemed to show that only the positive phase of the incident wave was critical, calculations indicated that, if the window worked as desired, the negative phase would also be a problem for the front panel. And, as a practical matter, the incorporation of polymer films, even the “clear” type, tends to increase the opacity of a window (increasing, of course, as the total thickness of film increases). Therefore, for Design 4 (see schematic in Figure 4), a key design change was implemented. Rather than having one relatively thick clear polymer film, three relatively thin films were used. This configuration was designed to provide tensile reinforcement for the back panel (for the initial “burst” from the incident pressure), and also to provide tensile reinforcement to the front panel under both the positive and negative phases of the incident pressure, but still have total thickness of clear polymer film less than that of the previous designs. Other design criteria for the Design 4 prototype window was exactly as for the Design 3 prototype (see previous discussion in section titled “Design 3”). In addition, more care was used in the application of the protective polymer layer sprayed around the edges of the front panel (i.e., to prevent “pull-out”).

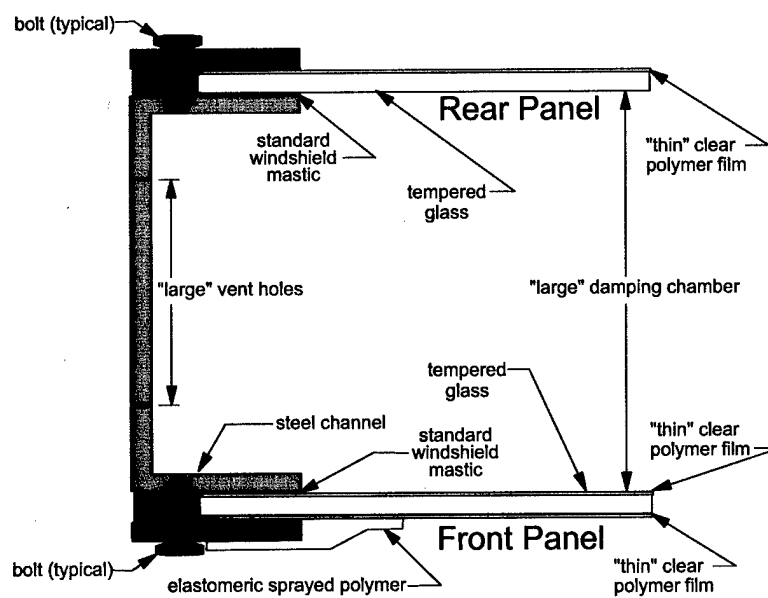

Figure 4. First Generation Window, Design 4.

**Blast Testing of Design 4 Prototype.** When the Design 4 prototype window was subjected to the design blast (at the new standoff distance), it performed much better than the Design 3 prototype window; but (as is often the case), solving one design problem exposed another. Although the Design 4 prototype did not have the “pull-out” problem previously experienced, underneath the protective polymer spray layer the marbled glass had some

displacement, and acted (for want of a better explanation) like little "saw teeth" which cut the films away from the edges of the frame. This effect was more pronounced in the front panel. However, even in the absence of a complete failure of the back panel, there were enough "slits" around the back panel edges to make the window system unable to resist a subsequent chem-bio attack.

### Second Generation Windows (Terror Threat)

Using the lessons learned from the First Generation combined threat windows of the early 1990s, a new generation of windows were developed. The Second Generation incorporated the successful concepts from the First Generation (i.e., membrane and damping chamber concepts), and the same basic elements (i.e., rigid metal frames, vent holes, tempered glass, and clear polymer film), but added the key concept of thin film anchoring to overcome the First Generation problems previously identified. Specific materials and concepts used in the Second Generation windows are discussed subsequently, in the body of the paper. Collectively, these Second Generation windows are referred to as the "Blast Proof Window Systems with Damping Chamber."<sup>PP>>6</sup>

## BLAST PROOF WINDOW SYSTEMS WITH DAMPING CHAMBER<sup>PP</sup>

### Overall Glazing System Design

The basic design of the Second Generation window is illustrated in Figure 5. The glazing system is composed of six major components: (1) double panels (glass and film assemblies); (2) damping chamber; (3) rigid metal frame; (4) rigid window frame; (5) flexible rubber and caulking (film anchoring system); and (6) air vents.

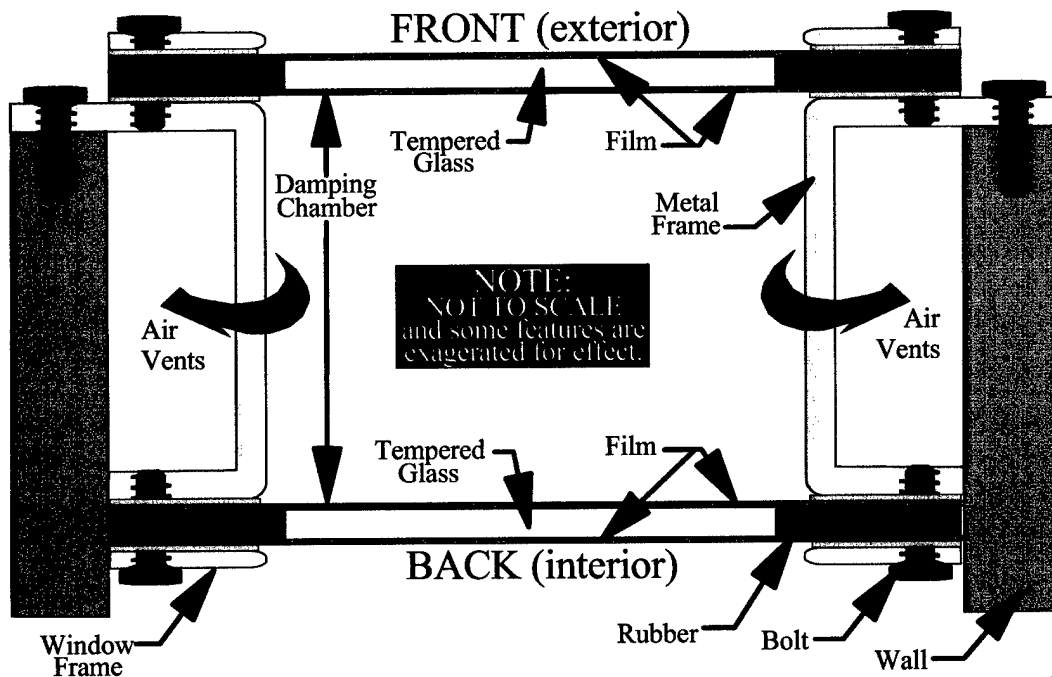

Figure 5. Basic System Design, Blast Proof Window Systems with Damping Chamber<sup>PP</sup>.

<sup>6</sup> Patent pending.

The rigid metal frame is made with steel channel beams. A key design improvement of the Second Generation windows was reversing the interior steel channels, so that the open channel faced the wall, thereby eliminating the "knife edge" effect encountered in the First Generation windows (i.e., the glass marbleized and the shards cut against the edge of the steel channel). In addition, this new configuration allows the damping chamber to be an integral part of the window assembly, thereby making the system more versatile (i.e., it will work on a wider variety of walls), as the air vents have room within the framing system to relieve the air pressure between the front and back panels. The panels may be anchored to the rigid frame with several configurations, but generally utilize metal plates (i.e., the window "frame"), silicone caulking, and bolts.

The front and back panels are laminate structures. Each of the panels uses a single tempered glass pane with film on each side. Each film is also a laminate, consisting of multiple layers (i.e., multi-ply) of thin clear polymer film. Another key design improvement in the Second Generation windows is the use of a butyl rubber edging, which was also enclosed by the clear polymer films (using the film tail anchoring concept).

Several different anchor designs were used within the basic design framework shown in Figure 5. These designs, and the results of explosive testing, are discussed in subsequent sections. Actual frames for Second Generation windows are shown in Figure 6. Two Second Generation frames are shown in Figure 7, mounted in rigid test structures which simulate an actual retrofit configuration. When possible, the windows were mounted in enclosed structures for blast testing; however, some of the tests were done with the rigid test structures shown in Figure 7. Actual test data verified that the rigid test structures worked adequately, compared to enclosed structures. Figures 8, 9, and 10 show P-I curves<sup>7</sup> for the front, inside, and back pressure gauges, respectively. Comparing the three figures, the front and inside pressures are high (69 and 102 psi, respectively), but the pressure at the back was almost negligible (9 psi). This gives objective proof that the rigid test structures were adequate to simulate the results from an enclosed structure.

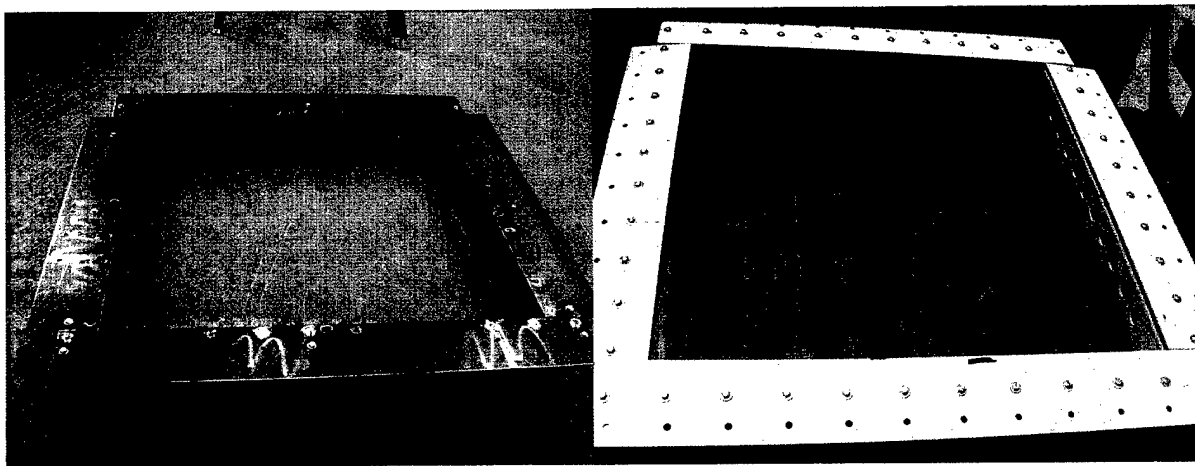

(a) Bare frame.

(b) Completed frame, including a coating of protective polymer sprayed on.

Figure 6. Second Generation Window Frames.

<sup>7</sup> P-I Curves are combined plots of Pressure-Time history and Impulse-Time history.

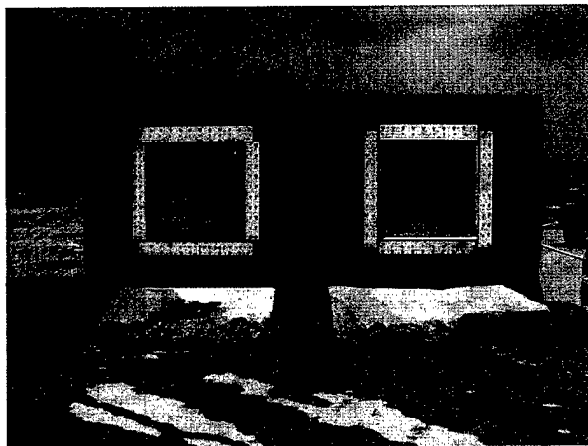

Figure 7. Second Generation windows mounted in rigid test structures.

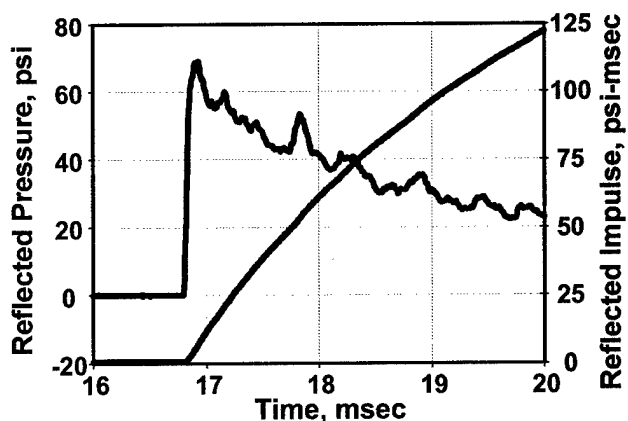

Figure 8. Typical P-I Curve, front gauge.

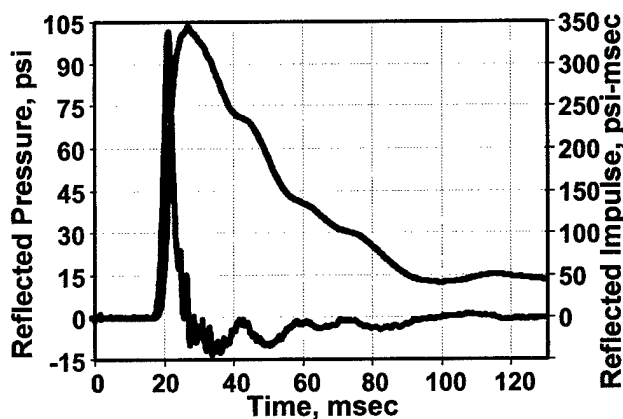

Figure 9. Typical P-I Curve, inside gauge.

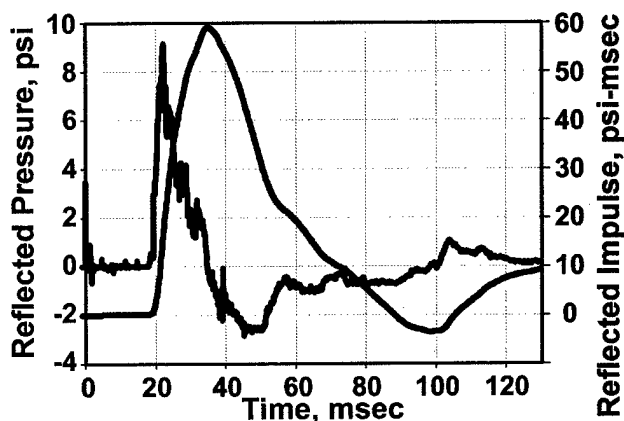

Figure 10. Typical P-I Curve, back gauge.

## Second Generation Anchor Designs

**Anchor Design 1.** In the Design 1 anchoring system, shown in Figure 11, the butyl rubber was used as an anchor for the film tails, but the glass panels were still partially inserted into the metal frames. This design improvement isolated the effects of the film tail as to pull-out (that is, Design 1 used the butyl rubber / film laminate to hold the panel in place, even if the glass pane marbled). A second key design improvement was the rounding of the steel in the anchoring area, thereby providing a sharp contrast with the First Generation windows with respect to "cutting" by marbled glass shards.

**Blast Testing of Anchor Design 1 Prototype.** The Anchor Design 1 prototype was subjected to a blast with measured peak reflected pressure of 77-psi and measured reflected impulse of 206 psi-msec. The window retained all of its pre-blast weight,<sup>8</sup> and both panels stayed anchored to the frames. However, the exterior film sheared along the perimeter.

<sup>8</sup> Also referred to as RET=1, where  $RET = (\text{glass weight after blast}) / (\text{glass weight before blast})$ .

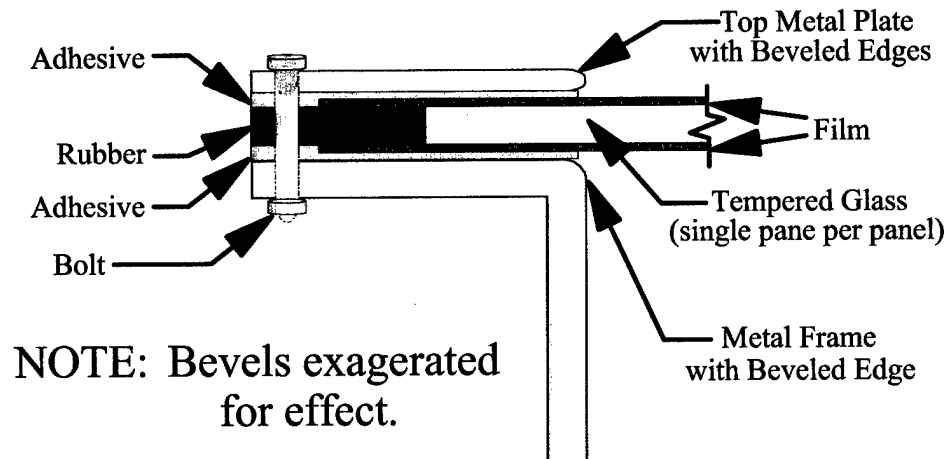

Figure 11. Second Generation Window, Anchor Design 1.

**Anchor Design 2.** In the Design 2 anchoring system, shown in Figure 12, the film tails were extended past the frame bolts so that the bolts would provide additional resistance to pullout. Otherwise, the Design 2 anchoring system was identical to the Design 1 system.

**Blast Testing of Anchor Design 2 Prototype.** The Anchor Design 2 prototype was subjected to a blast with measured peak reflected pressure of 69-psi and measured reflected impulse of 180 psi-msec. As expected, the window retained all of its pre-blast weight (i.e.,  $RET=1$ ), and both panels stayed anchored to the frames. However, the exterior film had two points where localized shearing occurred. While this represented a significant improvement over the Design 1 anchoring system, there was still some concern about the "cutting" action at the frame edges.

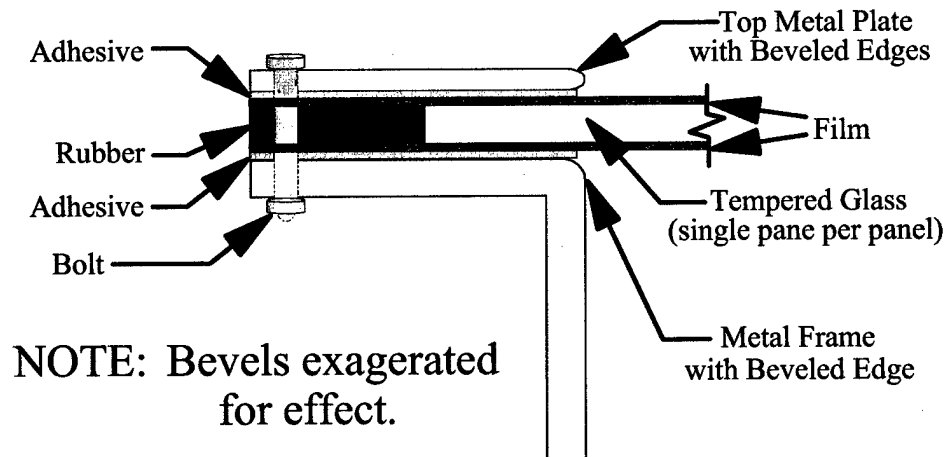

Figure 12. Second Generation Window, Anchor Design 2.

**Anchor Design 3.** In the Design 3 anchoring system, shown in Figure 13, the butyl rubber was extended beyond the metal frame, so that the glass pane was not inserted into the metal frame. This key design improvement was intended to stop the localized shearing of the exterior film. Although calculations indicated that this configuration would have adequate shear strength, there was a concern that the membrane action of the films could be less than expected. This design depends heavily on the membrane strength created by the clear polymer films, and it is that membrane action that is particularly troublesome to predict under blast loadings.

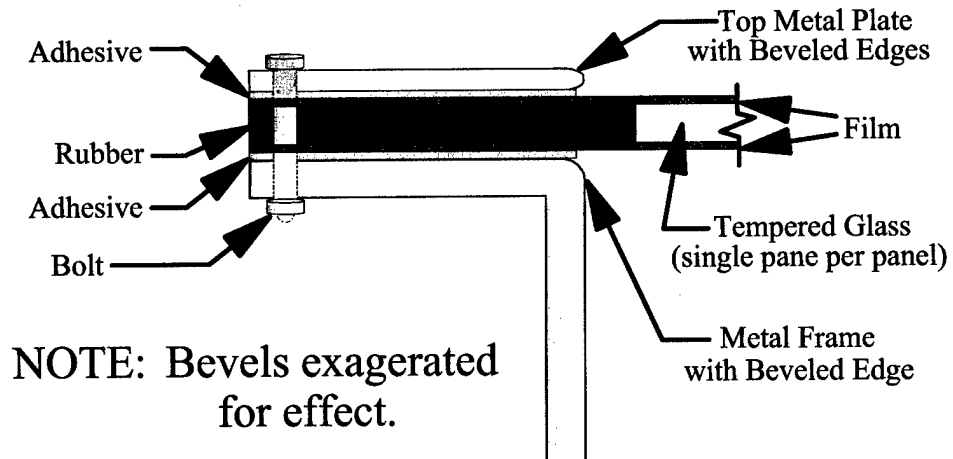
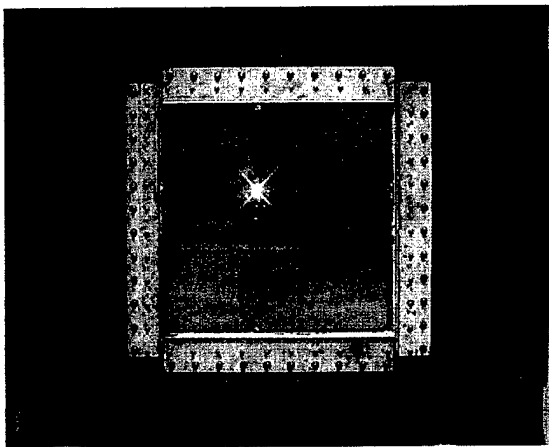
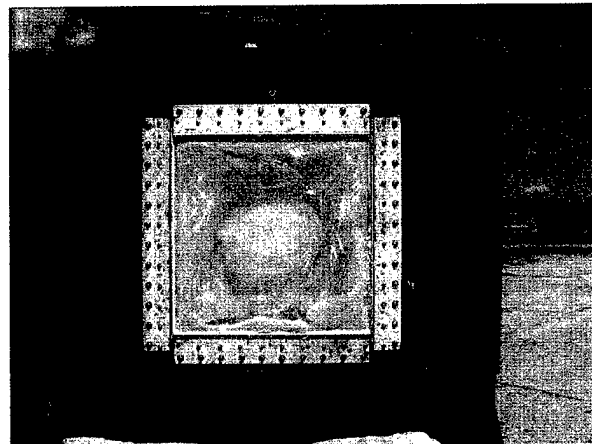

Figure 13. Second Generation Window, Anchor Design 3.



(a) Pre-blast, front panel.



(b) Post-blast, front panel.

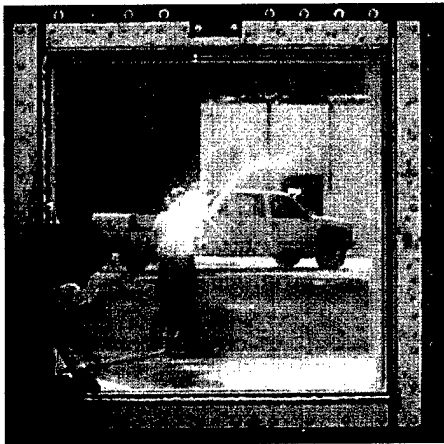

(c) Pre-blast, back panel.

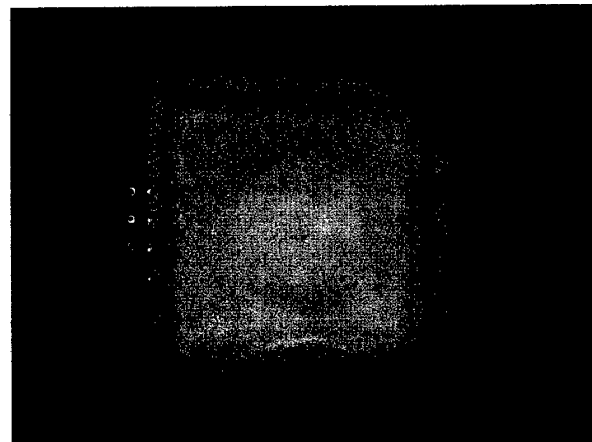

(d) Post-blast, back panel.

Figure 14. Pre-blast and post-blast views of Anchor Design 3.

**Blast Testing of Anchor Design 3 Prototype.** The Anchor Design 3 prototype was subjected to a blast with measured peak reflected pressure of 98-psi and measured reflected impulse of 237 psi-msec. As expected, the window retained all of its pre-blast weight (i.e., RET=1), and both panels stayed anchored to the frames. In this case, there was no shearing of the exterior film around the perimeter of the panel, but there was shearing in several random locations due to fragmentation (i.e., projectiles) from the blast. Otherwise, the panels performed as expected. Figure 14 shows the pre-blast and post-blast condition of both the front and back panels of the Design 3 prototype anchor system.

**Leakage Test of Post-Blast Anchor Design 3 Prototype.** Because of the extremely high blast pressure on the Design 3 anchor system, it was chosen for a "leak" test. That is, after the blast test was completed (see Figure 14(d)), the window assembly was removed from the wall and tested for leakage in a simple, but effective, test. To test the window system, it was turned horizontally (back panel down), and flooded with water to a depth of 2 inches. The window system was observed for 3 days, and had no leakage whatsoever. This finding was significant, because the blast pressures for this test were far above the original design criteria.

**Anchor Design 4.** In the Design 4 anchoring system,<sup>9</sup> shown in Figure 15, the panels were separated from the rigid frame using the butyl rubber. As shown in Figure 15, in this particular design, the butyl rubber has four separate functions: (1) as an anchor material at the rigid frame; (2) as an anchor material for the panel frame; (3) as a damping material during blast; and (4) as an impermeable barrier after blast. This configuration allows the window panels to move somewhat independently of the rigid frame, initially experiencing an elastic deformation pattern as the entire inner frame unit oscillates as a unit. At very high blast pressures, there is a point where the butyl rubber will not act elastically, and the panels will deform plastically as in the previous anchor designs. But, in effect, the previous capacity of the window system is added to the elastic deformation in the butyl rubber. That is, the overall capacity is greatly enhanced. This was a key design enhancement, which should allow the system to be expanded to a much larger surface area (hopefully, to store front size).

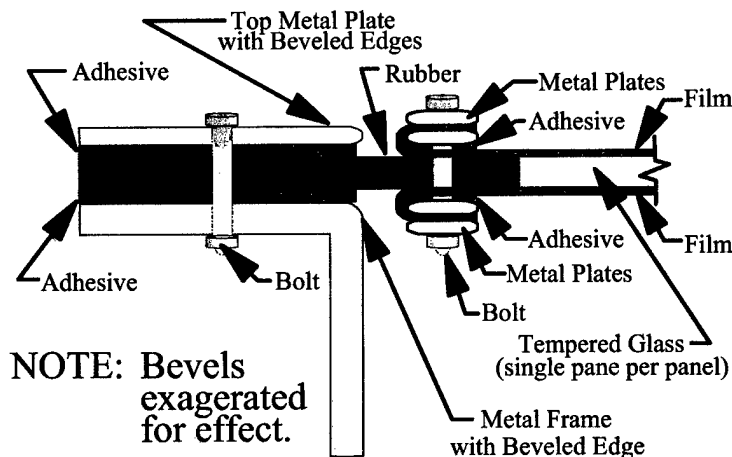
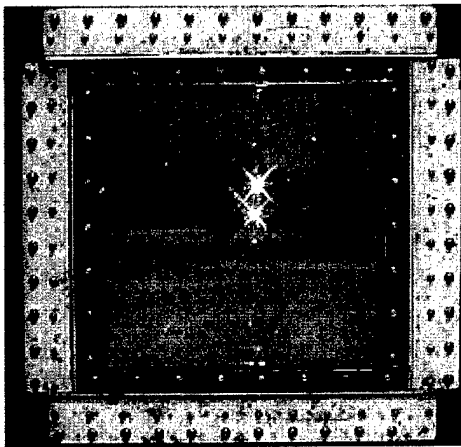

Figure 15. Second Generation Window, Anchor Design 4.

<sup>9</sup> Although Anchor Design 4 was completed at AFRL/MLQD, the design was based on some important suggestions by Mike Rochefort, P.E., of Applied Research Associates, Inc.

**Blast Testing of Anchor Design 4 Prototype.** The Anchor Design 4 prototype was subjected to a blast with measured peak reflected pressure of 61-psi and measured reflected impulse of 179 psi-msec. As expected, the window retained all of its pre-blast weight (i.e., RET=1), and both panels stayed anchored to the frames. Although the exterior film experienced some local shearing, a study of remote videotape taken during the blast test verified that the inner frame moved as a unit, as predicted, up to a point, and, at that point, the window began to deform plastically in a manner similar to its previous behavior in the rigid frame (but at a lower amplitude, as expected, since much of the energy was used up in the elastic deformation of the butyl rubber). That is, this anchoring system worked exactly as expected. This is particularly important because it indicates that windows of much larger area may be blast proofed by this method. Figure 16 shows the pre-blast and post-blast condition of both the front and back panels of the Design 4 prototype anchor system.



(a) Pre-blast, front panel.

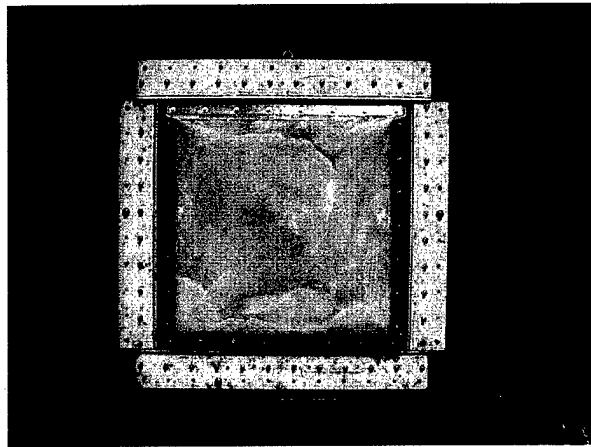

(b) Post-blast, front panel.

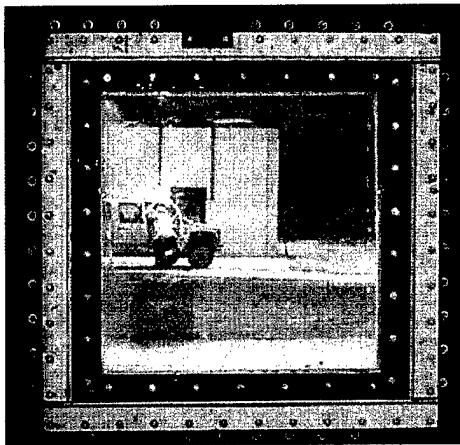

(c) Pre-blast, back panel.

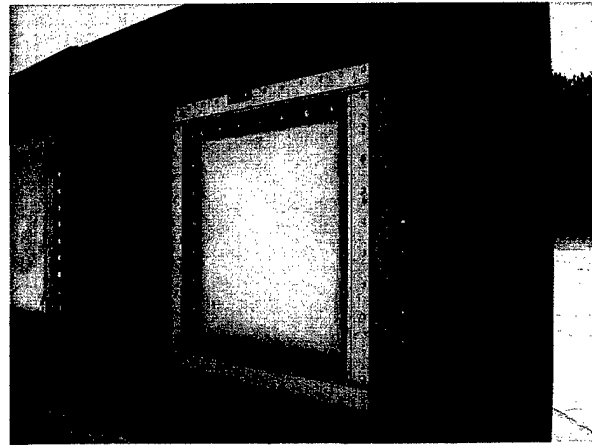

(d) Post-blast, back panel.

Figure 16. Pre-blast and post-blast views of Anchor Design 4.

**Anchor Design 5.** The Anchor Design 5 system was similar to Anchor Design 3, except in the method of attachment to the wall. In particular, the system was designed to become an

integral component with a retrofitted wall. The test for Design 5 used a CMU wall,<sup>10</sup> a particularly difficult test case (since the concrete blocks have very little tensile strength, and there is minimal reinforcement in the CMU wall). In this case, the CMU wall was undergoing retrofit blast protection with ESC.<sup>11</sup> The geometry of Anchor Design 3 was adapted slightly, and perforated plates were installed on the back of the window frames, and then attached as shown in Figure 17. The front metal plate (solid flange) was bolted to the front of the wall, as well as to the rigid window frame. The back metal plate (perforated plate) was bolted to the rigid window frame, and then attached to the back of the CMU wall as it was covered by the ESC (i.e., the entire CMU wall is coated on the inside with ESC). This attachment makes the window and wall, as much as possible, move simultaneously (as previously discussed).

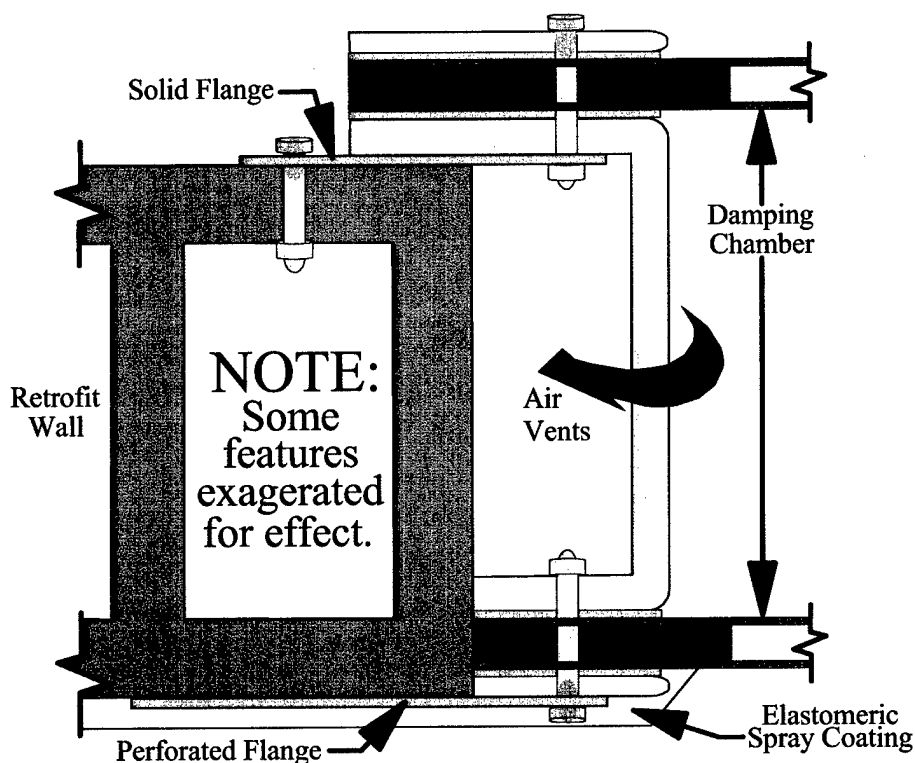

Figure 17. Second Generation Window, Anchor Design 5.

**Blast Testing of Anchor Design 5 Prototype.** The Anchor Design 5 prototype was subjected to a blast with measured peak reflected pressure of 38-psi and measured reflected impulse of 183 psi-msec. Figure 18 shows the pre-blast and post-blast condition of both the front

<sup>10</sup> CMU stands for concrete masonry unit, but the common term is "concrete block."

<sup>11</sup> See Maj. Dov Dover, P.E., Mark Anderson, Ph.D., P.E., and Randall W. Brown, Ph.D., P.E., *Recent Advances in Matting Technology for Military Runways*, Proceedings, 27<sup>th</sup> Annual International Air Transport Conference, American Society of Civil Engineers, Orlando, Florida, July 2002, for a more complete discussion on the use of ESC, or elastomer sprayed coating (in that paper ESC is described for use in runway repair).

and back panels of the Design 5 prototype anchor system. As expected, the window retained all of its pre-blast weight (i.e.,  $RET=1$ ), and both panels stayed anchored to the frames. The instrumentation and videotape records show a high degree of inward deformation in the supporting structure (the CMU wall would almost certainly have fallen without the retrofit application of ESC inside the structure), yet the window was relatively unharmed. In addition, there was no apparent shearing of the exterior film, despite severe damage on the exterior surface of the CMU wall (see Figure 18(b) for the post-blast CMU wall damage).

**Design 5 and other wall types.** Many types of walls which will be, or could be, retrofitted for blast protection have much better inherent blast protection properties than a CMU wall. Such walls should experience much less movement on blast impact, and will therefore work more like the rigid test structures used to test the Design 3 windows (as previously discussed). Based on testing a "worse-case scenario" (i.e., the CMU wall), and a "best-case scenario" (i.e., the rigid test structures), it seems that the Blast Proof Window Systems with Damping Chamber<sup>PP</sup> outfitted with the perforated flanges and sprayed with ESC (when the wall is also sprayed with ESC), will perform adequately for any type of retrofit wall.

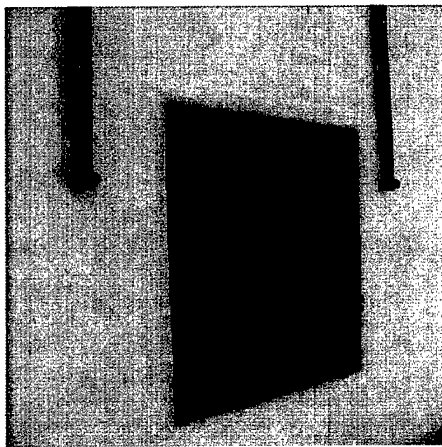

(a) Pre-blast, front panel.

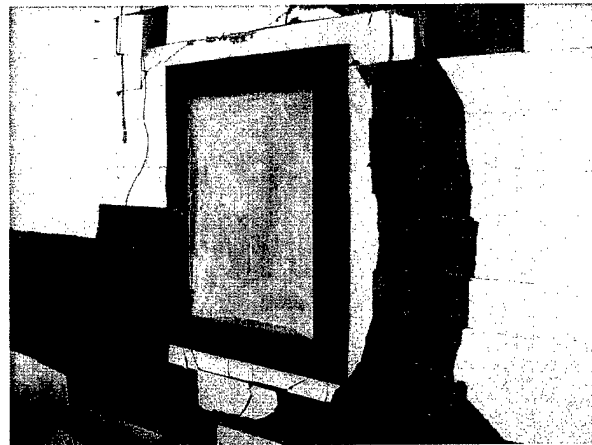

(b) Post-blast, front panel.

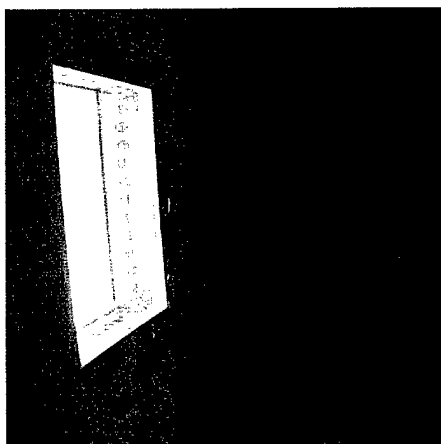

(c) Pre-blast, back panel.

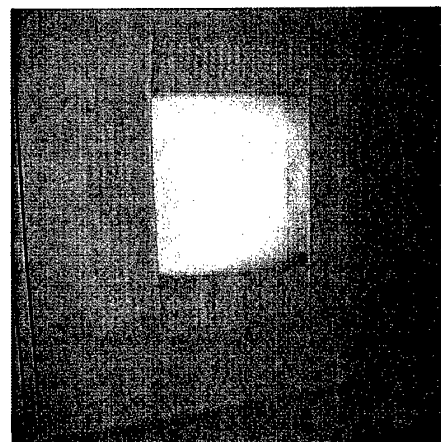

(d) Post-blast, back panel.

Figure 18. Pre-blast and post-blast views of Anchor Design 5.

## CONCLUSIONS

### Summary Conclusions

Overall, the results of the tests on the Blast Proof Window Systems with Damping Chamber<sup>PP</sup> were judged a tremendous success. Although the First Generation windows showed great promise, the Second Generation windows began to realize that promise. Observations verified that all of the Second Generation designs prevented glass shards from penetrating into the structure. More importantly, the observed results were supported by objective data, i.e., that the window systems retained all of their pre-blast weight (that is, RET=1). Also, the window systems were adequate not only for blast protection, but also for chem-bio protection (i.e., the combined threat), as the interior clear polymer film was kept undamaged and remained tightly anchored in the frames. Finally, one of the Anchor Designs (i.e., Anchor Design 4) was able to add a substantial amount of elastic deformation to the system to improve the overall capacity of the system.

### Choice of Alternatives

Based on the results presented herein, the decision was made to proceed with three of the anchor designs for future testing of the Blast Proof Window Systems with Damping Chamber,<sup>PP</sup> grouped by application. These are:

- (1) Anchor Design 3, for general purpose use against the combined threat.
- (2) Anchor Design 4, for special cases of interest, such as very large windows, or very high blast pressures. (NOTE: Although Anchor Design 4 showed the best potential of any method, the construction of this anchoring system is much more labor intensive (compare Figures 14 and 16), and therefore Anchor Design 3 was judged as a better general purpose design).
- (3) Anchor Design 5, for use in combination with ESC retrofit of inside walls.

### Planned Future Research

Several follow-on research and development studies are either currently underway, or will be underway soon. These include:

- (1) A test series has been planned with the Blast Proof Window Systems with Damping Chamber<sup>PP</sup> mounted in a conventional structure, with post-blast contamination testing using both liquid and gas intrusion tests.
- (2) In addition to the contamination studies, a series of "blast after blast" tests are planned for a conventional structure, to determine if the Blast Proof Window Systems with Damping Chamber<sup>PP</sup> is capable of withstanding multiple concussions without losing its integrity.
- (3) Computer modeling of the Blast Proof Window Systems with Damping Chamber<sup>PP</sup> is planned, which will allow parameter studies in the future, eventually reducing the number of blast tests required for verification of new system configurations.
- (4) Additional research is planned which will lead to large size Blast Proof Window Systems with Damping Chamber.<sup>PP</sup> This research should allow store front size windows (on the order of 100 square feet, or more) which can resist an explosive attack followed by a chem-bio attack (i.e., the combined threat), with no degradation in protection compared to smaller windows.