

# REPORT DOCUMENTATION PAGE

*Form Approved*  
**OMB No. 0704-0188**

Public reporting burden for this collection of information is estimated to average 1 hour per response, including the time for reviewing instructions, searching existing data sources, gathering and maintaining the data needed, and completing and reviewing this collection of information. Send comments regarding this burden estimate or any other aspect of this collection of information, including suggestions for reducing this burden to Department of Defense, Washington Headquarters Services, Directorate for Information Operations and Reports (0704-0188), 1215 Jefferson Davis Highway, Suite 1204, Arlington, VA 22202-4302. Respondents should be aware that notwithstanding any other provision of law, no person shall be subject to any penalty for failing to comply with a collection of information if it does not display a currently valid OMB control number. **PLEASE DO NOT RETURN YOUR FORM TO THE ABOVE ADDRESS.**

<b>1. REPORT DATE (DD-MM-YYYY)</b> Nov 1993		<b>2. REPORT TYPE</b> Technical Paper		<b>3. DATES COVERED (From - To)</b>	
<b>4. TITLE AND SUBTITLE</b>  (See attached)				<b>5a. CONTRACT NUMBER</b> F29601-91-C-0045	
				<b>5b. GRANT NUMBER</b>	
				<b>5c. PROGRAM ELEMENT NUMBER</b>	
<b>6. AUTHOR(S)</b>  (See attached)				<b>5d. PROJECT NUMBER</b> 3058	
				<b>5e. TASK NUMBER</b> 00DG	
				<b>5f. WORK UNIT NUMBER</b>	
<b>7. PERFORMING ORGANIZATION NAME(S) AND ADDRESS(ES) AND ADDRESS(ES)</b>  (See attached)				<b>8. PERFORMING ORGANIZATION REPORT NUMBER</b>  CPIA Publication 602, Vol II, Nov 93	
<b>9. SPONSORING / MONITORING AGENCY NAME(S) AND ADDRESS(ES)</b>  Air Force Research Laboratory (AFMC) AFRL/PRS 5 Pollux Drive Edwards AFB CA 93524-7048				<b>10. SPONSOR/MONITOR'S ACRONYM(S)</b>	
				<b>11. SPONSOR/MONITOR'S REPORT NUMBER(S)</b> PL-TP-94-3062	
<b>12. DISTRIBUTION / AVAILABILITY STATEMENT</b>  (See attached)					
<b>13. SUPPLEMENTARY NOTES</b> These are technical papers, presentations that have been presented by AFRL/PRS from 1994. 1993 Propulsion Meeting, 15-19 Nov 93, Monterey, CA					
<b>14. ABSTRACT (maximum 200 words)</b>  (See attached)					
<div style="border: 1px solid black; padding: 10px; display: inline-block;"> <h2 style="margin: 0;">20040204 288</h2> </div>					
<b>15. SUBJECT TERMS</b>					
<b>16. SECURITY CLASSIFICATION OF:</b>			<b>17. LIMITATION OF ABSTRACT</b>	<b>18. NUMBER OF PAGES</b>	<b>19a. NAME OF RESPONSIBLE PERSON</b>
<b>a. REPORT</b>	<b>b. ABSTRACT</b>	<b>c. THIS PAGE</b>			Kenette Gfeller or Leilani Richardson
Unclassified	Unclassified	Unclassified	SAR		<b>19b. TELEPHONE NUMBER</b> (include area code) DSN 525-5015 or 525-5016

## FOAM INFLATED RIGIDIZED STRUCTURES FOR SPACE APPLICATIONS

D.M. Lester, M.J. Warner, and M. Blair  
Thiokol Corporation  
Brigham City, Utah

### ABSTRACT

Large lightweight stowable structures that can be deployed in space without astronaut extra vehicular activity are vital to expanding space exploration and utilization. To meet this challenge Foam Inflated Rigidized (FIR) structures have been developed by Thiokol Corporation on the Air Force's Gossamer Baggie Torus program. In this paper the development, proof of concept demonstration of an eight foot diameter octagonal torus, and design application of this technology for structural elements to stabilize the solar collector of a solar thermal rocket are discussed.

A FIR structure uses foam to inflate and pre-stress a resin impregnated fabric skin. The predeployed foam used was a solvent swelled polymer that foams immediately when exposed to vacuum due to rapid solvent loss. This property allows a very simple deployment mechanism to be used in erecting these structures. Once inflated, the skin resin is cured using the available ultraviolet radiation. By using high strength and stiffness fiber materials a stiff, strong lightweight structure was produced.

### INTRODUCTION

Solar Thermal Propulsion is an innovative concept to economically transport large payloads from low earth orbit to geosynchronous orbit, or to perform interplanetary transfer missions. This concept uses the sun's energy to heat cryogenically stored hydrogen to very high temperatures (3,000 K - 4,000 K). The heated hydrogen then exits a nozzle at high velocity converting thermal energy into kinetic energy. The resulting low thrust propulsion system is very efficient with specific impulse ( $I_{sp}$ ) approaching 1,000 seconds.<sup>1</sup> An essential element of the success of this concept is the ability to collect, concentrate and point the sun's energy. Large inflatable solar concentrators that can be accurately pointed are an important element of the overall design.<sup>2</sup>

A toroidal support ring that stabilizes the concentrator and provides attach points for a support truss system is an element of many solar concentrator designs<sup>3</sup>. Development of a planar torus that, when loaded, does not significantly distort the reflector surface has been a formidable challenge of the solar thermal propulsion program.<sup>4</sup>

- 
- <sup>1</sup> Laug K. "The Solar Propulsion Concept is Alive and Well at the Astronautics Laboratory" (AFSC) Edwards Air Force Base, California, JANNAF Propulsion Meeting, Cleveland Ohio, May 1989.
  - <sup>2</sup> Gierow P. A., "Fabrication of Thin Film Concentrators for Solar Thermal Propulsion Applications", SRS Technologies, Huntsville Al., pp.345 Solar Engineering, ASME, 1991.
  - <sup>3</sup> Etheridge F. G., "Solar Rocket Systems Analysis" Air Force Rocket Propulsion Laboratory, Report # AFRPL-TR-79-79, Edwards Air Force Base Ca., December 1979.
  - <sup>4</sup> Gierow P., W. Clayton, D. Kromis, "Concentrator Technology Final Report", PL-TR-92-3030, Phillips Laboratory Propulsion Directorate, Air Force Materials Command, Edwards Air Force Base Ca., September 1992.

Approved for public release; distribution is unlimited.

The Gossamer Baggie Torus Program was successful in the development, proof-of-concept demonstration and design of a foam inflated/rigidized (FIR) structure to meet this challenge.

## DISCUSSION

A FIR structure is a foam inflated composite tube that is rigidized after inflation. Woven E-glass tubes impregnated with ultraviolet curing resin were inflated and prestressed using dichloromethane swelled polystyrene foam. Immediately after inflation the resin was cured making a rigid E-glass tube filled with polystyrene foam. Stiffness of the structure was derived from the E-glass composite skin. The foam eliminates the need for make up inflation gas of traditional inflatable systems and increases the structural damage tolerance<sup>5</sup>.

The basic predeployed configuration of the FIR construction system is shown in Figure 1. When exposed to a low pressure environment the foam immediately begins to expand. This expansion causes the skin to unfold and inflate to form the final structural element shown schematically in Figure 2. The FIR construction deployment method uses a head-to-head deployment concept. Foam deploys simultaneously from facing canisters to fill the beam from the center to the outside. The head-to-head filling method effectively cuts the filling distance in half.

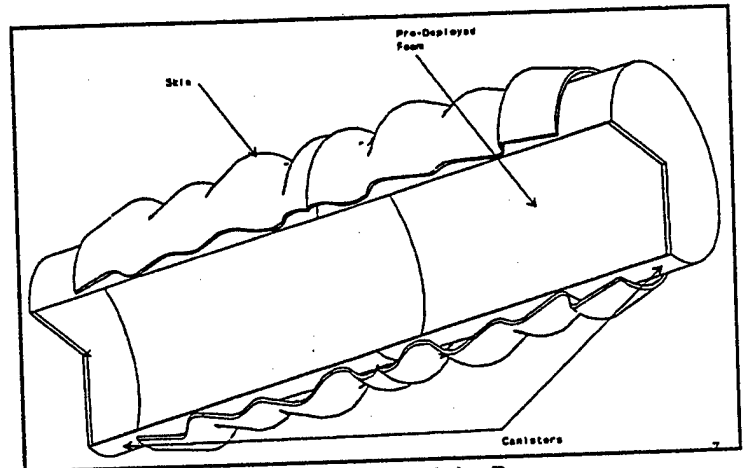

Figure 1 Pre-Deployed Straight Beam

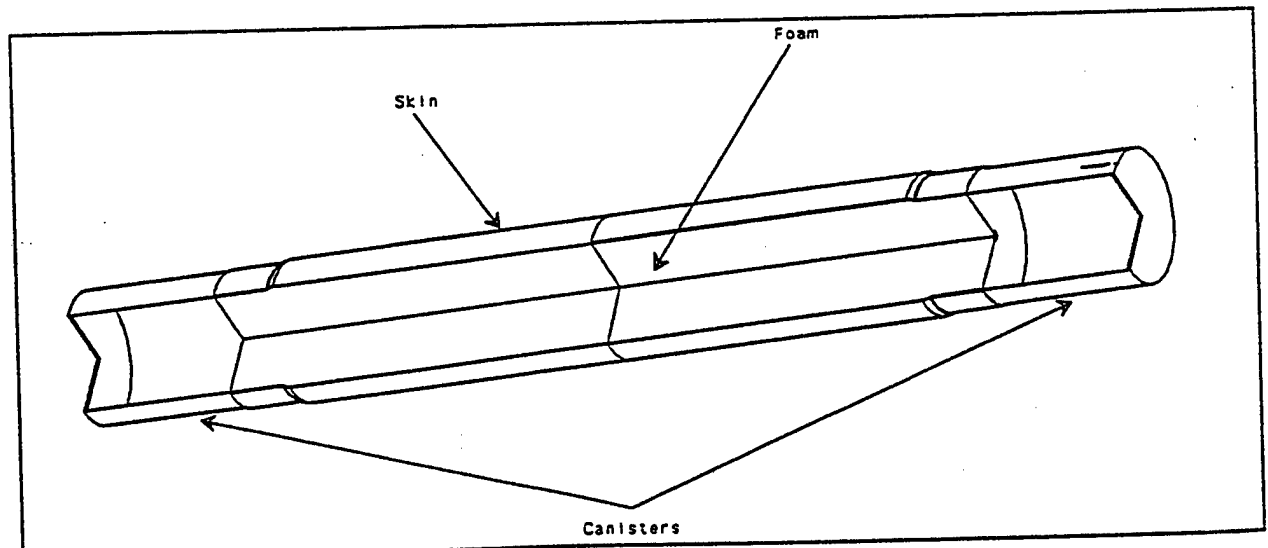

Figure 2 Inflated and Rigidized Beam

<sup>5</sup> Opt Cit., Etheridge, F. G.

E-glass was selected as the fiber material to be used in the proof-of-concept demonstration. This selection was made due to its low cost, compatibility with the space environment (atomic oxygen resistance), and transparency to ultraviolet (UV) light. The resin system selected was Sartomer's acrylated bisphenol A epoxy. This Sartomer resin is available and commonly used commercially in UV resin curing applications.

Seven straight FIR beams were tested in a cantilever bending mode to obtain cursory material properties. These beams were then sectioned and tested to obtain the compressive properties. Average values obtained from this testing were used in the baseline design of the torus structure. These results showed that the foam material increased the average buckling strength of the skin by a factor of 2.28. The average buckling strength observed for the FIR beam was 5.7 ksi.

### BASELINE DESIGN FOR INITIAL TORUS

A baseline torus was designed to support and position a 7X9 meter inflated reflector and provide a rigid boundary to maintain the required reflector accuracy of 10,000:1. The reflector geometry and internal pressure were obtained from previous reflector work<sup>6</sup>. The 7X9 meter reflector is a 1/40 scale model of the full size reflector needed for a solar propulsion rocket motor.

A finite element model of the 7X9 meter reflector was used to define the loads induced into the torus from the reflector inflation pressure, and assess the torus support on reflector accuracy. The torus structure was modeled with a displacement boundary condition on the edge of the reflector model. This allowed the torus stiffness to be varied without complex model gridding. Figure 3 shows the finite element model used to simulate the reflector. Figure 3 also shows the locations of the boundary conditions used to model the torus structure.

A method to quantify the change in accuracy of a reflector supported by a flexible torus was developed that used the displacement results from the finite element solutions. The edge displacements of the reflector were calculated by dividing the reaction force at a node by a spring rate constant. The nodal forces were obtained from the reflector finite element solution with zero displacement.

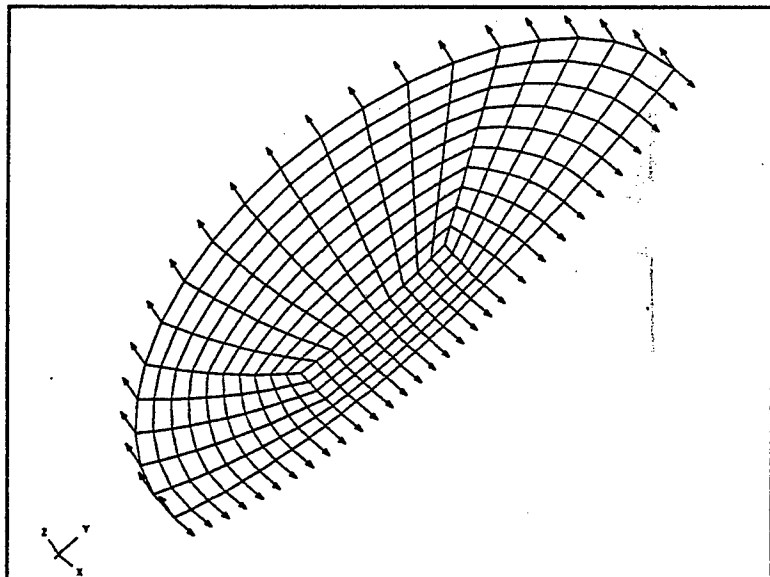

Figure 3 Finite Element Model of 7X9 Reflector

<sup>6</sup> Crow G. C., "Thin Film Creep-Forming for Solar Thermal Propulsion Applications, Midterm Report October 1988", SRS/STD-TR89-23 5289, SRS Technologies, Huntsville AL., October 1988.

The accuracy of the reflector was then calculated as the average miss distance of reflected light rays that would pass the theoretical focal point of a perfect parabola. Each element of the reflector model was used to define a reflected light vector and the miss distance. Figure 4 shows the average miss distance of the finite element model as a function of the torus spring rate. It was concluded from these data that the torus structure should have a spring rate of 40 lb/in or greater to reduce the error effects induced by the torus structure to an acceptable level.

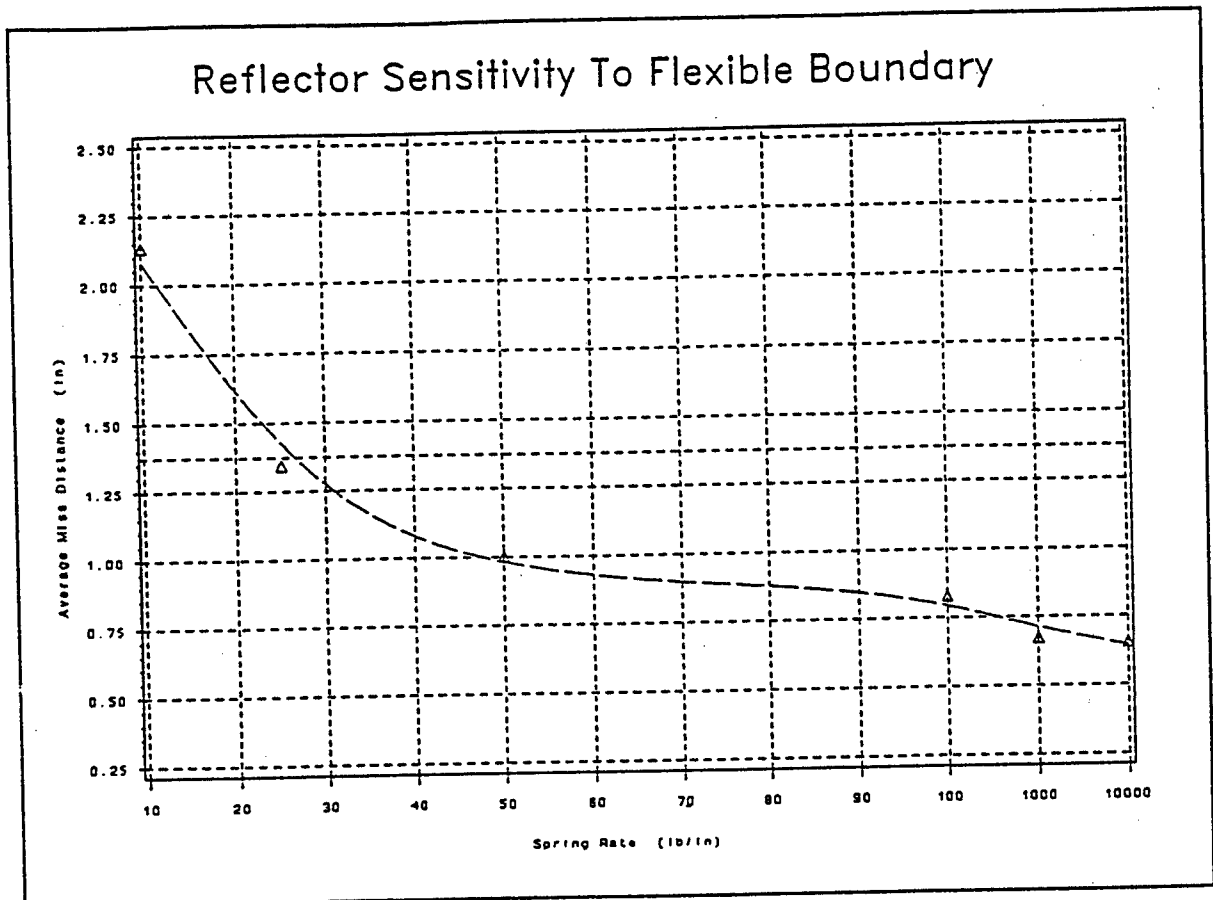

Figure 4 Reflector Sensitivity Versus Boundary Edge Conditions

A simple finite element model of the torus structure and attachments was completed to relate the torus stiffness to the required spring rate and also obtain the loads induced into the torus. The torus was modeled with linear beam elements and the attachment structure with rod elements. The reflector loads were applied to the ends of the attachment elements. The torus elastic modulus (E) and moment of inertia (I) values were varied to obtain the torus displacement as a function of  $E \cdot I$ . These finite element models indicated that the torus stiffness needed to be  $5 \times 10^6$  lb-in<sup>2</sup> to provide the required stiffness of 40 lb/in. These results also showed that the maximum bending moment in the torus is 58 in-lbs and the maximum compressive load is 10 lbs.

E-Glass skin and polystyrene foam were used in the torus design. Material testing of the lab samples showed that the E-Glass FIR has a material modulus that is approximately  $1 \times 10^6$  psi and a minimum buckling strength of 5.1 ksi. These material values were used to design the torus structure.

The torus was designed to meet the stiffness requirement of  $5 \times 10^6$  lb-in<sup>2</sup>, minimum material strength of 5.1 ksi, and minimum weight. The initial design was to use curved beams. The development of curved woven E-Glass was not within the scope of this project and straight woven material was used for the torus design. A polygon with N sides closely approximates a circle as the number of sides increases. Figure 5 shows a plot of the weight ratio of a circle to a polygon with n segments. This shows that a 12 sided polygon has 2.3% more weight than a circular structure. The reduction in weight does not significantly decrease beyond 12 segments. Also an ellipse reduces the structure weight by 11%. Thus, a 12 segment elliptical torus structure was used for the design.

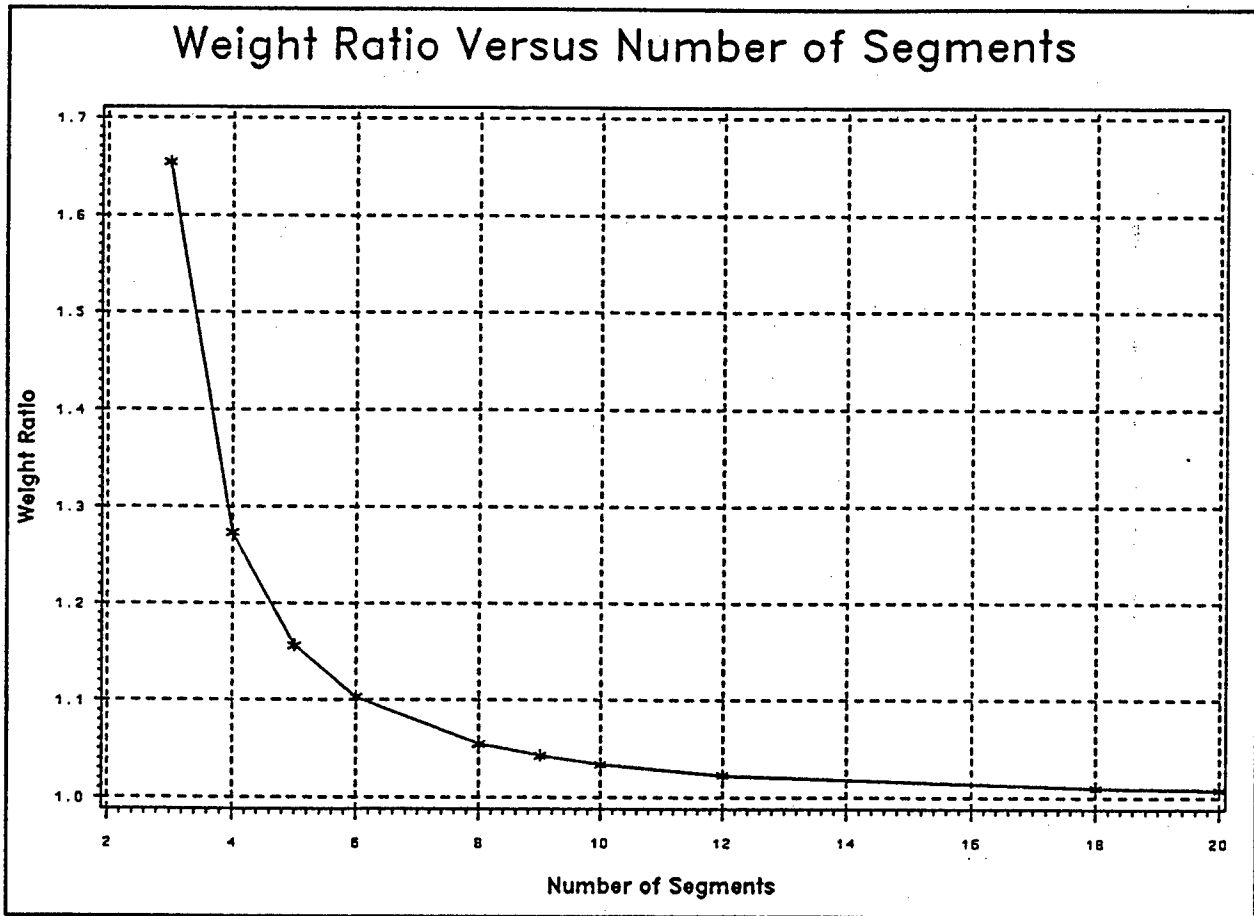

Figure 5 Weight Ratio Versus Number of Straight Segments

The foam material is the major contributor of weight to the FIR structure, yet it carries very little of the structural loads. The FIR structure stiffness and strength is provided by the skin material. However, the foam provides the inflation of the FIR skin and does strengthen the skin from buckling. The total torus weight is minimized by reducing the amount of foam required to complete a FIR structure. Material testing shows that the skin elastic stiffness is approximately  $1 \times 10^6$  psi. Thus, the torus structure was required to have a I of 5 in<sup>4</sup>.

The torus structure was optimized by reducing the cross sectional area and holding the moment of inertia constant. Several cross sections were used to complete the optimization. The initial cross section considered for the torus structure was a single FIR beam. A circular section would need to have a diameter of 7.785 inches and a skin thickness of 0.027 inch. This has a weight of 0.239 lb/in.

The cross section that uses 3 circular FIR beams arranged in a triangular pattern was evaluated. As the distance from the section center is increased, the FIR diameter is decreased which reduces the required foam material. A cross section that uses three 2.125 inch FIR beams on a 8.7 diameter has a weight of 0.078 lb/in. Figure 6 shows the comparison of the single FIR beam cross section to the three FIR beams.

Figure 7 shows the three FIR beam torus design to support a 7X9 meter reflector. The torus has a weight of 104 lbs. Figure 8 shows a closeup view of the deployment canisters and FIR beams.

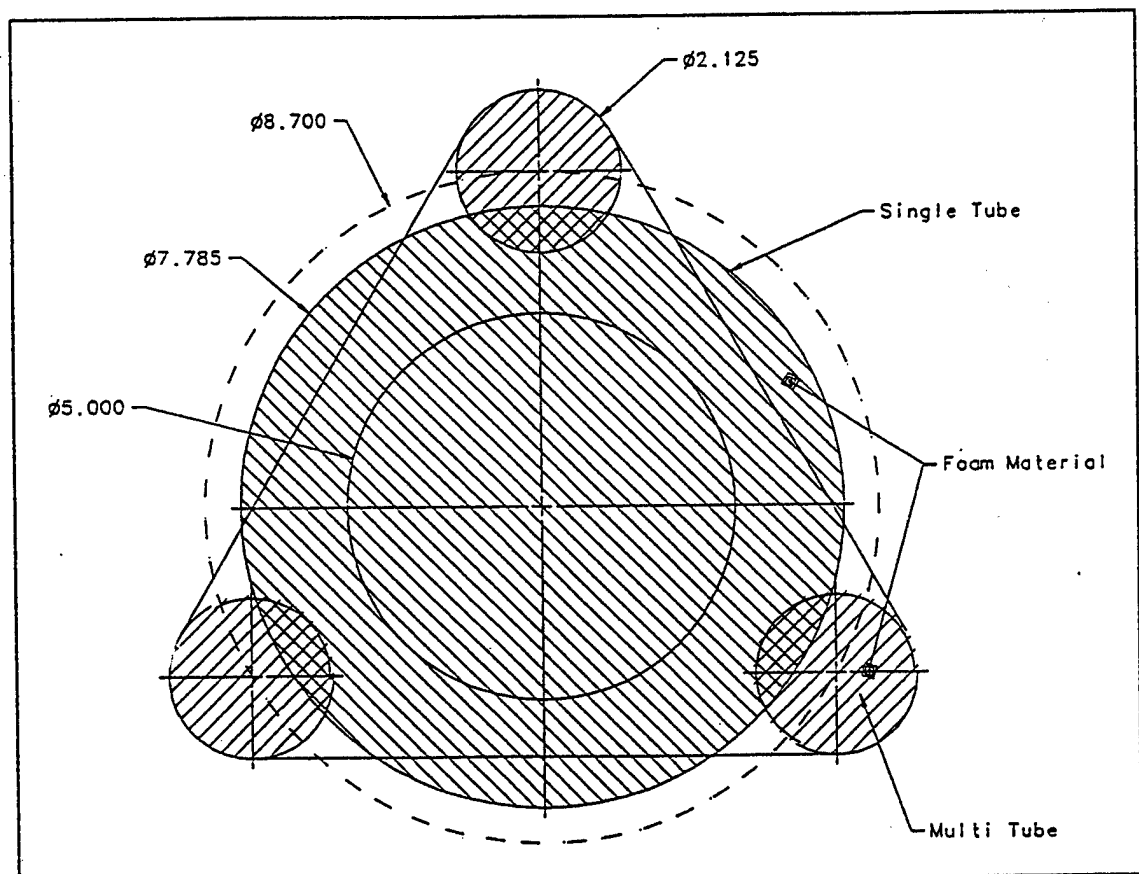

Figure 6 Torus Structure Cross Section

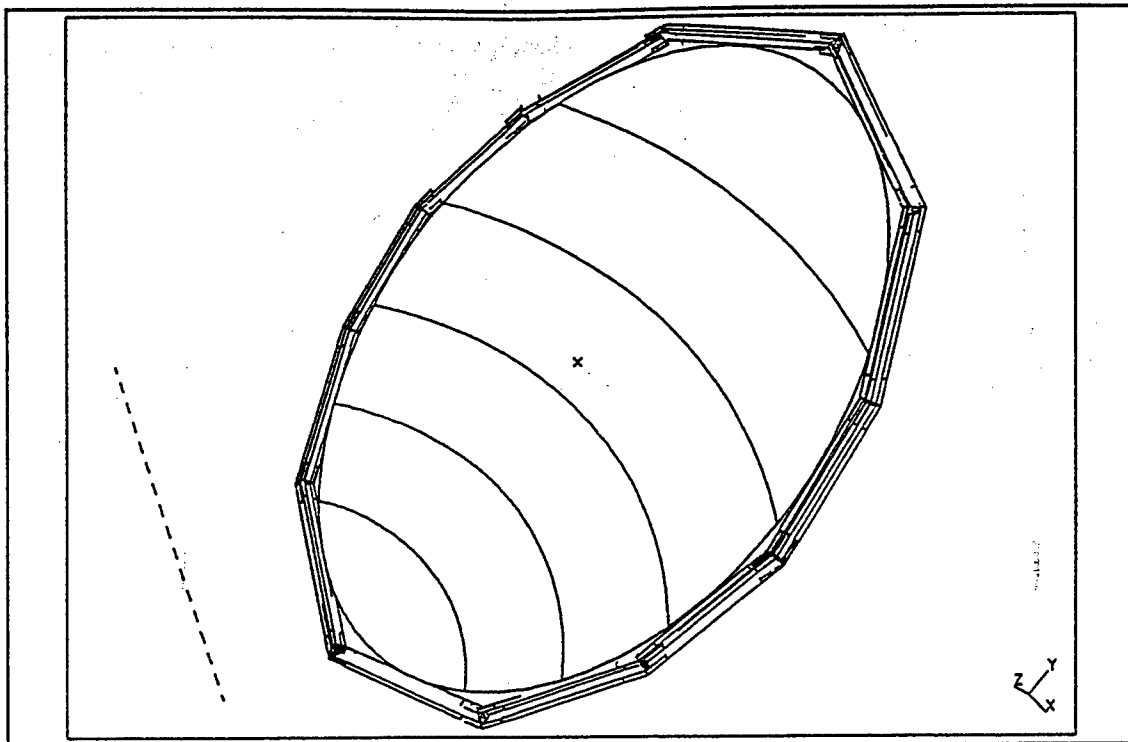

Figure 7 7X9 Elliptical Torus Design

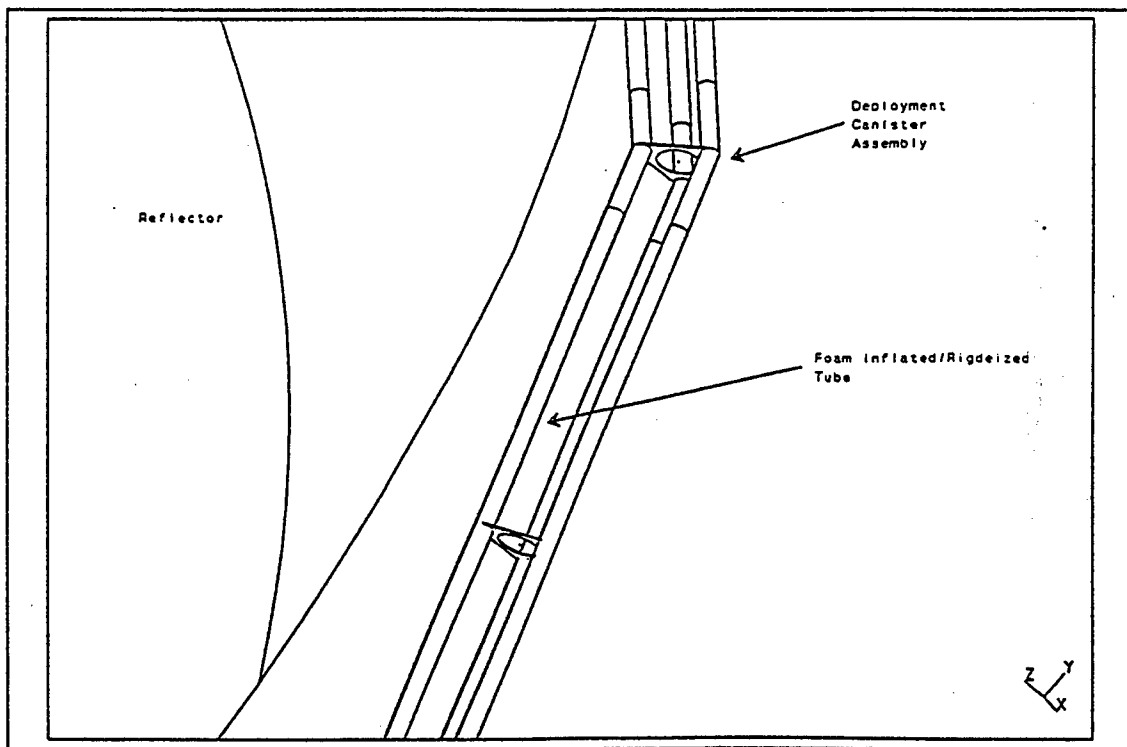
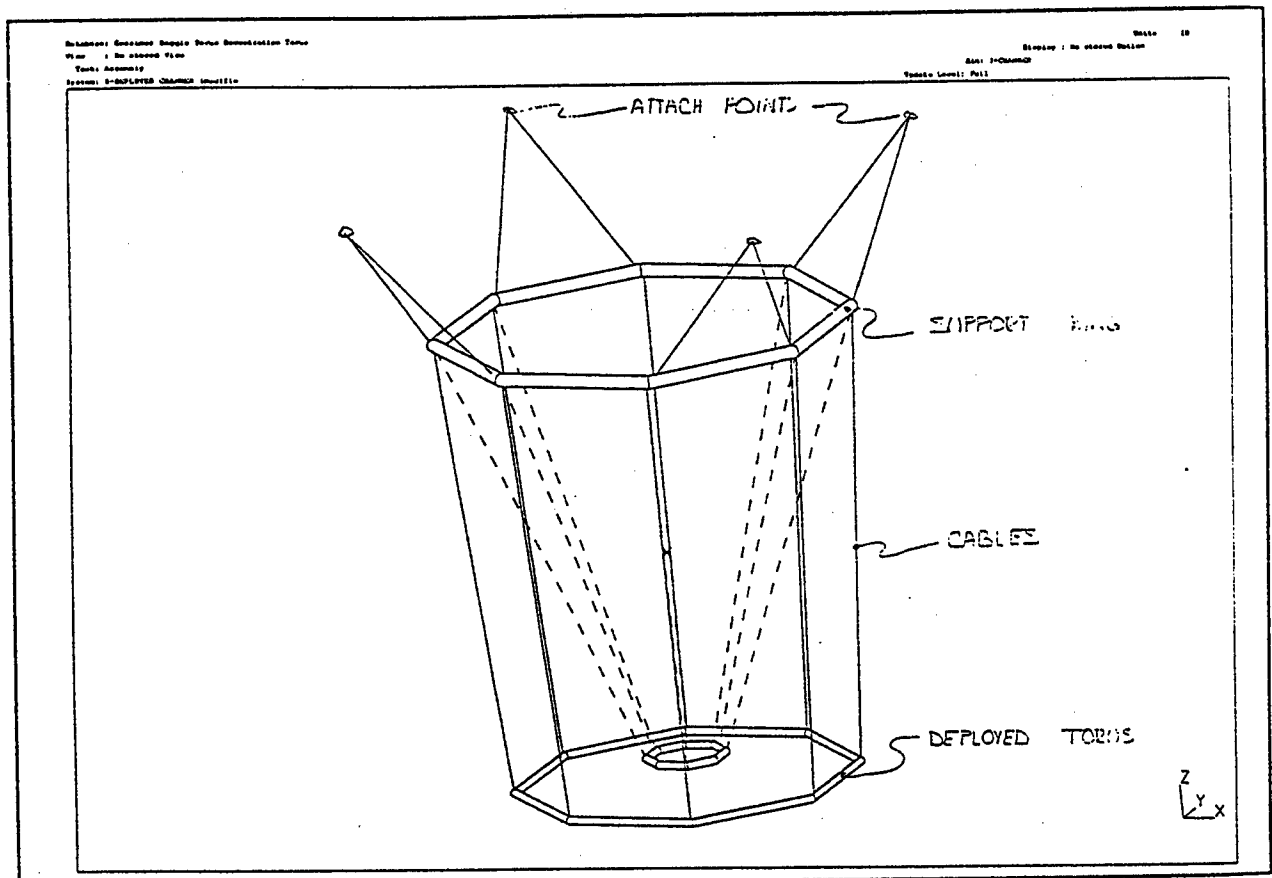

Figure 8 Torus Structure Canisters

## PROOF-OF-CONCEPT DEMONSTRATION

On 28 January 1993 a proof-of-concept deployment of an eight foot diameter torus was performed in Phillips Laboratories Space Environmental Facility (SPEF). The highly successful deployment was recorded on video tape. The test apparatus consisted of eight bi-directional deployment canisters. When stowed, the skin was folded in an accordion configuration on opposing deployment canisters. The effects of gravity on the deploying apparatus were somewhat negated by hanging the deployment apparatus from a suspension support ring. Figure 9 shows a isoparametric sketch of the support ring and deployment torus.



**Figure 9** Isoparametric View of the Support Ring and Torus

Post test analysis showed that an eight foot diameter torus was fully deployed. However, close examination showed that foam did not completely fill all of the beams. To hold the torus in the predeployed position a hot wire trigger was used. Due to an anticipated delay this wire was cut two seconds after the deployment sequence was begun. This two second delay was too long resulting in beam buckling during the initial deployment sequence. The beam sections that contained foam voids correspond to the initial deployment beam buckling regions. In future deployments, the hot wire will be cut simultaneous with initiation of the deployment sequence. It is anticipated that this action will eliminate the voids observed. The deployment of the 8 foot diameter torus was successful in demonstrating the deployment concepts and hardware. Some gravitational sagging was seen in the cured FIR beams. The level of this sag was likely due from slow skin resin curing. Gravity sag will not be a factor in microgravity deployment.

Slow skin resin curing was caused by the level of UV light available inside the SPEF vacuum chamber. The UV curing lights used in the SPEF chamber were placed approximately 6-8 feet away from the FIR structure. This distance is significantly farther than the 1-2 feet used during Thiokol Laboratory tests. Irradiance at the surface is equal to the radiant intensity divided by the distance squared. By moving the UV curing lights approximately 4 feet farther away a 16 fold reduction in surface irradiance was seen.

Post test evaluation showed that the skin wrinkled during cure. The foam shrank as dichloromethane was volatilized from the foam. If the skin cured rapidly the foam would shrink to the skin resulting in a higher density foam at the skin surface. Since the skin was not cured, the foam collapsed inwardly on itself resulting in a wrinkled skin.

This successful deployment demonstrated the proof-of-concept that a foam inflated/rigidized (FIR) structure could be used to form a torus structure. Multiple FIR structural units can be deployed simultaneously to form large useful structures. A clear advantage of this technology is that deployment is accomplished by simply exposing the inflation foam to the low pressure environment. Secondary mechanical devices are not required.

To move beyond the proof-of-concept demonstration, FIR structures will be characterized for deployment reproducibility, the ability to form complex shapes, aging properties, mechanical properties, and contamination characteristics. Continued research to improve FIR technology development will center on replacement of dichloromethane as the polymer swelling solvent with a non-halogenated solvent, and evaluation of alternate foam inflation, skin resin, and skin fiber materials.