



**NAVAL  
POSTGRADUATE  
SCHOOL**

**MONTEREY, CALIFORNIA**

**THESIS**

**CONSTRUCTION AND TESTING OF LOW-NOISE  
HYDROPHONES**

by

Miguel Alvarado Juarez

December 2003

Thesis Advisor:

Thomas J. Hofler

Second Reader:

Andres Larraza

**Approved for public release; distribution is unlimited**

THIS PAGE INTENTIONALLY LEFT BLANK

<b>REPORT DOCUMENTATION PAGE</b>			<i>Form Approved OMB No. 0704-0188</i>
Public reporting burden for this collection of information is estimated to average 1 hour per response, including the time for reviewing instruction, searching existing data sources, gathering and maintaining the data needed, and completing and reviewing the collection of information. Send comments regarding this burden estimate or any other aspect of this collection of information, including suggestions for reducing this burden, to Washington headquarters Services, Directorate for Information Operations and Reports, 1215 Jefferson Davis Highway, Suite 1204, Arlington, VA 22202-4302, and to the Office of Management and Budget, Paperwork Reduction Project (0704-0188) Washington DC 20503.			
<b>1. AGENCY USE ONLY (Leave blank)</b>	<b>2. REPORT DATE</b> December 2003	<b>3. REPORT TYPE AND DATES COVERED</b> Master's Thesis	
<b>4. TITLE AND SUBTITLE:</b> Construction and Testing of Low Noise Hydrophones			<b>5. FUNDING NUMBERS</b>
<b>6. AUTHOR (S)</b> Miguel Alvarado-Juarez			
<b>7. PERFORMING ORGANIZATION NAME (S) AND ADDRESS(ES)</b> Naval Postgraduate School Monterey, CA 93943-5000			<b>8. PERFORMING ORGANIZATION REPORT NUMBER</b>
<b>9. SPONSORING /MONITORING AGENCY NAME(S) AND ADDRESS(ES)</b> N/A			<b>10. SPONSORING/MONITORING AGENCY REPORT NUMBER</b>
<b>11. SUPPLEMENTARY NOTES</b> The views expressed in this thesis are those of the author and do not reflect the official policy or position of the Department of Defense or the U.S. Government.			
<b>12a. DISTRIBUTION / AVAILABILITY STATEMENT</b>  Approved for public release; distribution is unlimited			<b>12b. DISTRIBUTION CODE</b> <b>B</b>
<b>13. ABSTRACT (maximum 200 words)</b> Several hydrophones have been constructed exploiting the advantages of the MiniCan design. One of them is unamplified and two are amplified. Comparison in sensitivity, self-noise, size and price with known and reliable commercial hydrophones yield the following results. The unamplified MiniCan has a sensitivity 22 dB re 1 V/μPa higher than a Brüel & Kjør type 8103 up to 20 KHz and the amplified MiniCans are compared to their similar and relatively expensive commercial hydrophones. The self-noise level of the amplified MiniCans is significantly lower than those of the B&K 8106 and Reson TC4032. The size of these preamplified MiniCan units is at least 18 times smaller in volume than the largest of the aforementioned. Moreover, the cost of the piezoceramic material and electronics components is around \$30 USD, compared to purchase prices of \$3095 and \$2500 USD for the B&K 8106 and Reson TC4032 respectively.  The is shows a relatively cheap hydrophone that is more sensitive than a typical hydrophone and better self-noise than the least noisy commercial hydrophone in the market while being smaller and much cheaper.			
<b>14. SUBJECT TERMS</b> Hydrophone, Sound receiver, Transducer.			<b>15. NUMBER OF PAGES</b> 66
			<b>16. PRICE CODE</b>
<b>17. SECURITY CLASSIFICATION OF REPORT</b> Unclassified	<b>18. SECURITY CLASSIFICATION OF THIS PAGE</b> Unclassified	<b>19. SECURITY CLASSIFICATION OF ABSTRACT</b> Unclassified	<b>20. LIMITATION OF ABSTRACT</b> UL

THIS PAGE INTENTIONALLY LEFT BLANK

**Approved for public release; distribution is unlimited**

**CONSTRUCTION AND TESTING OF LOW-NOISE HYDROPHONES**

Miguel Alvarado-Juarez  
Lieutenant, Mexican Navy  
B.S., Mexican Naval Academy, 1994

Submitted in partial fulfillment of the  
requirements for the degree of

**MASTER OF SCIENCE IN ENGINEERING ACOUSTICS**

From the

**NAVAL POSTGRADUATE SCHOOL  
December 2003**

Author: Miguel Alvarado-Juarez

Approved by: Thomas J. Hofler  
Thesis Advisor

Andres Larraza  
Second Reader

Kevin Smith  
Chair, Engineering Acoustics Academic Committee

THIS PAGE INTENTIONALLY LEFT BLANK

## ABSTRACT

Several hydrophones have been constructed exploiting the advantages of the MiniCan design. One of them is unamplified and two are amplified. Comparison in sensitivity, self-noise, size and price with known and reliable commercial hydrophones yield the following results. The unamplified MiniCan has sensitivity 22 dB re 1 V/ $\mu$ Pa higher than a Brüel & Kjær type 8103 up to 20 KHz and the amplified MiniCans are compared to their similar and relatively expensive commercial hydrophones. The self-noise level of the amplified MiniCans is significantly lower than those of the B&K 8106 and Reson TC4032. The size of these preamplified MiniCan units is at least 18 times smaller in volume than the largest of the aforementioned. Moreover, the cost of the piezoceramic material and electronics components is around \$30 USD, compared to purchase prices of \$3095 and \$2500 USD for the B&K 8106 and Reson TC4032 respectively.

The is shows a relatively cheap hydrophone that is more sensitive than a typical hydrophone and better self-noise than the least noisy commercial hydrophone in the market while being smaller and much cheaper.

THIS PAGE INTENTIONALLY LEFT BLANK

# TABLE OF CONTENTS

<b>I.</b>	<b>INTRODUCTION.....</b>	<b>1</b>
<b>A.</b>	<b>BACKGROUND .....</b>	<b>1</b>
<b>B.</b>	<b>MOTIVATIONS .....</b>	<b>3</b>
<b>II.</b>	<b>THEORY AND DESIGN .....</b>	<b>5</b>
<b>A.</b>	<b>BASIC MINICAN DESIGN.....</b>	<b>5</b>
<b>B.</b>	<b>FET PREAMPLIFIER.....</b>	<b>8</b>
<b>III.</b>	<b>HYDROPHONES CONSTRUCTED .....</b>	<b>13</b>
<b>A.</b>	<b>MINICAN 3 .....</b>	<b>13</b>
<b>B.</b>	<b>MINICAN 4 .....</b>	<b>14</b>
<b>C.</b>	<b>MINICAN 5.....</b>	<b>16</b>
<b>D.</b>	<b>MINICAN 6 .....</b>	<b>18</b>
<b>IV</b>	<b>MEASUREMENT METHODOLOGY .....</b>	<b>21</b>
<b>A.</b>	<b>PREAMP MEASUREMENTS .....</b>	<b>21</b>
<b>B.</b>	<b>MINICAN MEASUREMENTS.....</b>	<b>22</b>
<b>V.</b>	<b>RESULTS AND DISCUSSION .....</b>	<b>29</b>
<b>A.</b>	<b>PREAMP MEASUREMENTS .....</b>	<b>29</b>
<b>B.</b>	<b>MINICAN MEASUREMENTS.....</b>	<b>31</b>
<b>C.</b>	<b>HYDROPHONE NOISE MEASUREMENTS.....</b>	<b>37</b>
<b>VI.</b>	<b>CONCLUSIONS .....</b>	<b>43</b>
	<b>INITIAL DISTRIBUTION LIST .....</b>	<b>45</b>

THIS PAGE INTENTIONALLY LEFT BLANK

## LIST OF FIGURES

Figure 1.	The Basic MiniCan design. $\vec{P}$ Represents the polarization vector of the PZT material. ....	5
Figure 2.	MiniCan design acting as a mass-loaded bar.....	6
Figure 3.	Split of the MiniCan design at the fundamental mode. ....	7
Figure 4.	“A simple 2-stage, single-ended JFET preamp”. <sup>8</sup> .....	9
Figure 5.	Schematics of the feedback preamp.....	11
Figure 6.	MiniCan design with radial stress reducing features machined into the aluminum parts.....	14
Figure 7.	Backside of the Switchcraft Tini QG three pin connector.....	17
Figure 8.	MiniCan design with an internal circular step to reduce the radial constraints. ....	18
Figure 9.	Photo of the arrangement used to obtain the Acceleration Sensitivity.....	23
Figure 10.	Photo of the mechanical filter used to reduce the noise due to environmental vibrations with mounted hydrophone under test.....	26
Figure 11.	Schematics of the whole systems to measure the self-noise of the hydrophone. ....	27
Figure 12.	Equivalent Input Noise in nV/ $\sqrt{\text{Hz}}$ of the flexible preamp used in MiniCan 5 with zero source impedance.....	29
Figure 13.	Equivalent input noise of the flexible preamp used in MiniCan 6 with zero source impedance.....	30
Figure 14.	Equivalent input noise of preamplifier used in MiniCan 5 with simulated hydrophone source impedance.....	31
Figure 15.	Plot of the electrical admittance (Y)- and phase ( $\theta$ ) of the potted MiniCan 4 in air using the HP4194A Impedance Analyzer.....	32
Figure 16.	Free Field Voltage Sensitivity of MiniCan 3 using two different sound sources in two frequency ranges.....	34
Figure 17.	Free Field Voltage Sensitivity of MiniCan 4 using two different sound sources in two frequency ranges.....	35
Figure 18.	Free Field Voltage Sensitivity of MiniCan 5 using two different sound sources in two frequency ranges.....	36
Figure 19.	Free Field Voltage Sensitivity of MiniCan 6 using two different sound sources in two frequency ranges.....	37
Figure 20.	Self-Noise Pressure Level of MiniCan 3 in dB re 1 $\mu\text{Pa}/\sqrt{\text{Hz}}$ compared to Wenz’s minimum plus thermal noise. ....	38
Figure 21.	Self-Noise Pressure Level of MiniCan 5 in dB re 1 $\mu\text{Pa}/\sqrt{\text{Hz}}$ compared to Wenz’s minimum plus thermal noise. ....	39
Figure 22.	Self-Noise Pressure Level of MiniCan 5 in dB re 1 $\mu\text{Pa}/\sqrt{\text{Hz}}$ compared to two large and expensive commercial hydrophones. ....	40
Figure 23.	Self-Noise Pressure Level of MiniCan 6 dB re 1 $\mu\text{Pa}/\sqrt{\text{Hz}}$ compared to Wenz’s minimum plus thermal noise. ....	41
Figure 24.	Self-Noise Pressure Level of MiniCan 6 in dB re 1 $\mu\text{Pa}/\sqrt{\text{Hz}}$ compared to two large and expensive commercial hydrophones. ....	42

THIS PAGE INTENTIONALLY LEFT BLANK

## LIST OF TABLES

Table 1.	Main characteristics of MiniCan 3.....	14
Table 2.	Main characteristics of MiniCan 4.....	16
Table 3.	Main characteristics of MiniCan 5.....	18
Table 4.	Main characteristics of MiniCan 6.....	19

THIS PAGE INTENTIONALLY LEFT BLANK

## LIST OF ABBREVIATIONS, ACRONYMS, SYMBOLS

$A_{MC}$	Area of the MiniCan
APC	American Piezo Ceramics
$A_{PZT}$	Area of the PZT stack
B&K	Brüel & Kjær
$C_C$	Coupling Capacitance
$C_P$	Preamp Capacitance
<b>D</b>	Electric displacement vector
dB	Decibels scale
$e_n$	Equivalent input noise of the preamp
$e_s$	Equivalent input noise of the source
FET	Field Effect Transistor
FFVS	Free Field Voltage Sensitivity
<b>g</b>	Grams
$\tilde{g}_{ij}$	Piezoelectric voltage coupling matrix (3x6)
JFET	Junction FET
$k$	Wavenumber
$kT$	Boltzmann thermal energy
L	Length of the PZT bar
M	Mass of the MiniCan base
m	Mass of the MiniCan lid
$m_b$	Mass of the PZT bar

NPS	Naval Postgraduate School
nV	Nanovolts
$OCV_{PZT}$	Open Circuit Voltage intrinsic to the PZT material
$\vec{P}$	Polarization vector
pF	PicoFarad
PZT	Lead Zirconate Titanate
re	Relative to...
rHz	Square root of bandwidth in Hz
$R_d$	Drain resistance
$\vec{s}_{ij}^D$	Elastic compliance matrix at constant displacement field vector
$t$	Thickness of the PZT
USD	United States Dollars
$\rho$	Volume density
$\rho_L$	Linear density

THIS PAGE INTENTIONALLY LEFT BLANK

## ACKNOWLEDGMENTS

My eternal gratitude to all my professors during these two most intensive years of my career, but especially to my advisor Thomas J. Hofler from the Physics department for the countless hours of work, patience and guidance during the whole process of my thesis. Thanks to Jay Adeff and George Kashja for the machine works of the different models and molds.

Finally, I wish to thank to my wife Elizabeth and Sons Jose Miguel and Ronaldo, who have shared with me both the frustrations and triumphs of this research. Thank you for persevering with my absence and long hours required completing this thesis.

THIS PAGE INTENTIONALLY LEFT BLANK

# I. INTRODUCTION

## A. BACKGROUND

The wide use of hydrophones to communicate and detect sound in the ocean push the manufacturer to build them with high sensitivity, low noise and flat frequency response over a wide frequency range. The hydrophone by itself must be able to detect weak signals in the presence of surrounding noise caused by several different sources, and to drive long cables that can reach safer places where the signals can be processed. In order to achieve those performance capabilities, modern hydrophones are frequently built with an internal preamp. Commercial hydrophones usually fulfill the characteristic of having a self-noise pressure below Knudsen Sea-State-Zero but typically above Wenz's Minimum noise, which are the average and lowest levels of ocean noise present for zero wind respectively. Two of these commercial hydrophones are the Brüel & Kjær (B&K from now on) type 8106<sup>1</sup> and the Reson TC4032<sup>2</sup>, which have Equivalent Noise Pressure Levels of 30 and 29.5 dB re 1 $\mu$ Pa/ $\sqrt{\text{Hz}}$  at 1 kHz respectively.

These exceptional features on the above-mentioned commercial hydrophones increases their prices considerably, having a current cost of \$3095 and \$2500 USD respectively. This is the motivation for developing the MiniCan hydrophone, which consists of a small hydrophone having moderately better characteristics of self-noise than those commercial hydrophones, and is also simpler and much easier to build. The original version of the MiniCan has an outer diameter of 28.5 mm and height of 15.5 mm excluding encapsulation material. This size is much smaller than the compared hydrophones B&K type 8106 (182 mm in length and 32 mm in diameter), and Reson TC4032 (164.5 mm length and 38 mm diameter).

When constructing low-noise preamps to be installed in these hydrophones the following question arises -- Is preamp noise always a limiting factor? The answer depends on the nature of the signals you are trying to measure and the noise of the medium, since your final goal is to increase the signal to noise ratio. For example, if you

---

<sup>1</sup> Brüel & Kjær, Available [online] at: <http://www.bk.dk>, 8/21/2003.

<sup>2</sup> Reson Inc., Available [online] at: <http://www.reson.com>, 8/21/2003.

are measuring strong underwater signals, or detecting in very noisy environments the self-noise of the preamp has a negligible impact in the signal to noise ratio. However, if you need to detect a weak signals coming from a target of interest, and the ocean noise levels in the frequency band of interest is low, then the self-noise of the preamp matters. All real electronics components add noise to the signals that pass through them, therefore a careful selection and testing of the electronics components of the internal preamps was made to ensure reducing the self-noise at the minimum value. “Low-noise op-amps are likely to have noise voltages of about  $3 \text{ nV}/\sqrt{\text{Hz}}$ ”<sup>3</sup>. Our constructed preamps have noise voltages of 57 % the above-mentioned value, as we will see later in this thesis.

Another important characteristic of the MiniCan is the price, where the total cost of the internal parts oscillates around \$30 USD due to the fact that it uses 2 piezoceramic disks mounted on flat pieces of Aluminum, and relatively cheap electronic components. As is usually the case, the transduction material that we use here is a common piezoelectric ceramic material, or piezoceramic, also referred to as PZT, which is short for Lead (Pb) Zirconate Titanate.

Recent successes in the development of the MiniCan by NPS student Stavros Polydorou (Hellenic Navy), were:

- A 17 dB higher sensitivity (194.7 dB re 1V/ $\mu\text{Pa}$ ) compared to a hydrophone B&K type 8103 from 100Hz to 10 KHz for MiniCan 1.
- The manufacture of an ultra low-noise preamp of  $1.67 \text{ nV}/\sqrt{\text{Hz}}$  at 1 kHz (measured with a zero source impedance) for MiniCan 2.
- An intrinsic pressure sensitivity of  $-192.9 \text{ dB re } 1\text{V}/\mu\text{Pa}$  for MiniCan 2.
- Flat response in sensitivity from 10 Hz to 20 KHz (+1.5/-0.5dB) for MiniCan 2.

On the contrary, the problems or errors he encountered were the following:

- The measured sensitivity of  $-194.7$  is 6.9 dB less compared to the  $-187.8 \text{ dB}$  one expected from theory for MiniCan 1.
- Use of low melting point for soldering the PZT.
- Lack of professional quality molds for potting the hydrophones to eliminate irregularities on the external shape.

---

<sup>3</sup> Neil Storey, *Electronics A Systems Approach*, Addison-Wesley, Second edition, 1998, p.96.

- Use of ceramic material Navy type II, which was subsequently discovered to have poorer noise performance.

## B. MOTIVATIONS

The main motivations for the work in this thesis are to improve the sensitivity, self-noise performance and dynamic range with lower distortion, as well as the frequency response and omni-directionality of the transducers.

Improving the sensitivity of the MiniCans requires gluing the PZT material using a 2-part epoxy instead of low-melting point solder and hot plate, since this was the most likely a partial cause of the loss in sensitivity for MiniCan 1, due to the depolarization of the ceramic. Moreover, another way of improving sensitivity is by redesigning the aluminum parts with a internal circular step having a diameter slightly smaller than the diameter of the PZT, at the contact and bounding area of the PZT, to minimize the constraint of the radial strains on the PZT material.

Improving the self-noise performance on the constructed preamps required the use of higher value input or gate resistors, higher un-distorted input voltages, and lower input capacitances for the preamp. An ideal preamp is one that has infinite input impedance, no noise contribution, and zero output impedance. But, in practice no real preamplifier can achieve such idealized characteristics. However, we try to make the input impedance of the preamp much higher than the resistance of the source, and the output impedance of the preamp very much smaller than the impedance of the load. The previously used input or gate resistor on MiniCan 2 was made with metal film and had a value of 100 M $\Omega$ . This resistor is also large having a size of 10 mm x 10 mm x 2 mm. The hydrophones built for this research were made with the use of Ohmcraft's revolutionary fine line, thick film technology, called **FineFilm**.<sup>4</sup> The package size is 3 mm x 1.5 mm x 0.8 mm and a 1 G $\Omega$  resistor value was used on the flexible preamp for MiniCan 6. Also, higher input voltages by increasing the power supply were used to get corresponding values at the output. In addition to that the input capacitance of the preamp was lowered to make it negligible compared to that of the PZT material.

---

<sup>4</sup> SM series High Performance Chip Resistors, *OhmCraft*, Available [online] at <http://www.ohmcraft.com/>, 12/13/2002.

Improving the high frequency response and omni-directionality of the MiniCan required making the hydrophone smaller, and the metal and urethane exteriors rounded. Lowering the nominal size of the MiniCan makes the unit much smaller than the wavelength of the incoming sound pressure waves and consequently increases its omni-directionality. Lowering the size also decreases the mass of the metal parts and the use of smaller PZT that match the design accordingly. Since hydrophones in general are designed to operate below its resonance frequency, lowering the mass of the design brings the advantage of increasing the natural resonance frequency of the whole hydrophone. Therefore, the result is a flat frequency response without marked variations.

## II. THEORY AND DESIGN

### A. BASIC MINICAN DESIGN

The Minivan's design consists basically of two rigid cylindrical parts made of aluminum 6061-T6 assembled one inside the other and separated by a gap of approximately 0.30 mm. Two simple piezoelectric disks are joined by a copper foil of thickness 50  $\mu\text{m}$  and mounted inside the aluminum parts and. This design belongs to Professor Thomas J. Hofler from the Physics Department at NPS and the structure shown in the figure below is roughly similar to one described by Anan'eva in 1965.<sup>5</sup>

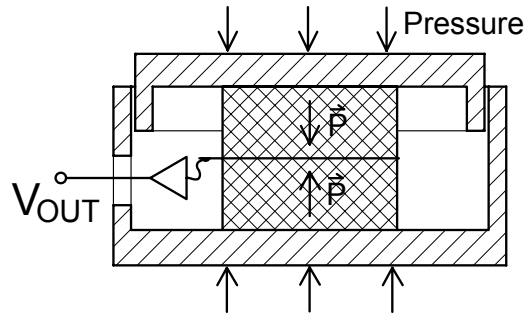

Figure 1. The Basic MiniCan design.  $\vec{P}$  Represents the polarization vector of the PZT material.

Since the piezoelectric ceramic parts have the property of generating a positive electric voltage when a force is applied in the direction of polarization (the 3-axis direction), the 2 PZT disks are connected back to back to generate an inward response that it is collected by the thin copper foil and coupled from there to the input of the preamp, or simply to the output cable, in the case of an un-amplified and reversible transducer. This design exploits the fact that the area of the aluminum parts exposed to the water pressure is bigger that the effective area of the PZT, resulting in greatly increase sensitivity, since the simple open circuit voltage sensitivity intrinsic to the PZT ( $OCV_{PZT}$ ) for an applied stress is  $OCV_{PZT} = g_{33}t$ , where  $g_{33}$  is one of the primary so-

---

<sup>5</sup> Alevtina Aleksandrovna Annan'eva, *Ceramic Acoustic Detectors*, translated from Russian, Consultants Bureau: New York, 1965.

called “voltage constants” of the PZT, and  $t$  is the PZT thickness. The MiniCan sensitivity is given by<sup>6</sup>

$$OCV_{PZT} = \left( \frac{A_{MC}}{A_{PZT}} \right) g_{33} t \quad (1)$$

Where  $A_{MC}$  represents the surface of the MiniCan that is in contact with the applied 3-direction stress, and  $A_{PZT}$  represents the surface of the PZT stack.

A simple theory to get the primary resonance frequency of the MiniCan was developed assuming that the PZT material acts like a mass-loaded bar, and the 2 aluminum parts, base and lid, act like attached masses at the ends of that bar, as described in the figure below:

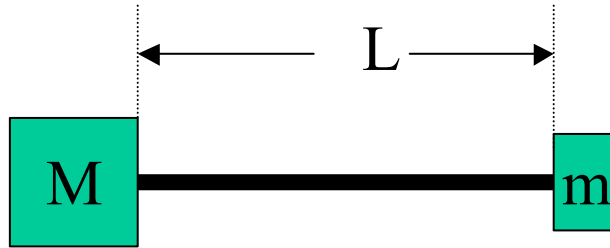

Figure 2. MiniCan design acting as a mass-loaded bar.

The PZT bar is modeled as an elastic element having a mass per unit length given by  $\rho_L$ . The symbol  $M$  represents the mass of the MiniCan base,  $m$  the mass of the MiniCan lid, and  $L$  the total length of the PZT material. Considering that the whole assembly moves coaxially in the 3-direction, and the fundamental mode has an internal node, then there is a point on the PZT bar that acts as the equilibrium point with no movement at all. So, the assembly can be split in two separated mass-loaded bars, as in the following figure.

---

<sup>6</sup> Stavros Polydorou, *A compact and inexpensive Hydrophone Having Ultra Low Self-Noise*, NPS thesis, 2002, p. 12-13.

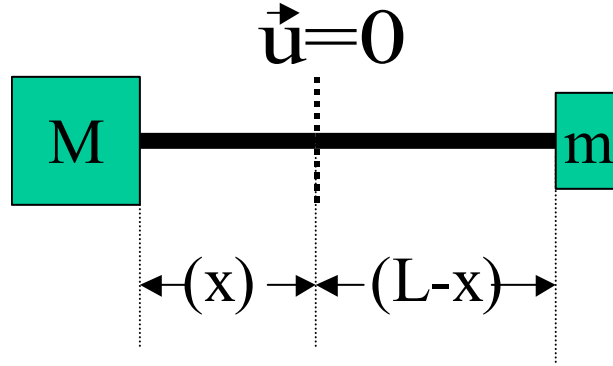

Figure 3. Split of the MiniCan design at the fundamental mode.

Using the formula of impedance of a mass-loaded bar equal to  $-j\rho_L c \cot kx$ <sup>7</sup> and making the Impedance analogy derivation on each part we get

$$-j\rho_L c \cot kx + j\omega M = 0 \quad (2)$$

$$-j\rho_L c \cot k(L-x) + j\omega m = 0 \quad (3)$$

From (2) we get  $\cot kx = \frac{M}{\rho_L} \frac{\omega}{c} \left( \frac{L}{L} \right) = \frac{M}{m_b} kL \rightarrow$

Where  $m_b$  represents the mass of the bar (PZT) equals to  $\rho_L L$ , and  $k = \frac{\omega}{c}$  is the wavenumber, then

$$\frac{1}{\tan kx} = \left( \frac{M}{m_b} kL \right) \rightarrow \tan kx = \left( \frac{m_b}{M} \frac{1}{kL} \right) \rightarrow$$

$$kx = \tan^{-1} \left( \frac{m_b}{M} \frac{1}{kL} \right) \quad (4)$$

From equation (3)  $\cot k(L-x) = \frac{m}{\rho_L} \frac{\omega}{c} \left( \frac{L}{L} \right) = \frac{m}{m_b} kL \rightarrow$

<sup>7</sup> Lawrence E. Kinsler, Austin R. Frey, Alan B. Coppens and James V. Sanders, *Fundamental of Acoustics*, Fourth Edition, John Wiley & Sons Inc., 2000, Eq. 2.9.14, p.48.

$$\frac{1}{\tan k(L-x)} = \left( \frac{m}{m_b} kL \right) \rightarrow \tan k(L-x) = \left( \frac{m_b}{m} \frac{1}{kL} \right) \rightarrow$$

$$k(L-x) = \tan^{-1} \left( \frac{m_b}{m} \frac{1}{kL} \right) \quad (5)$$

Adding equations (4) and (5) we get

$$kL = kx + k(L-x) = \tan^{-1} \left( \frac{m_b}{M} \frac{1}{kL} \right) + \tan^{-1} \left( \frac{m_b}{m} \frac{1}{kL} \right) \quad (6)$$

A value for  $kL$  is obtained using the values for the different masses when the MiniCan is potted or un-potted, amplified or un-amplified, and Excel to solve this transcendental equation by trial and error. The first resonance frequency is a function of  $kL$

$$kL = \frac{\omega}{c} L = \frac{\omega}{\sqrt{\frac{Y_{33}}{\rho}}} L = \frac{2\pi f}{\sqrt{\frac{Y_{33}}{\rho}}} L \rightarrow f = \frac{\sqrt{\frac{Y_{33}}{\rho}}}{2\pi L} kL \quad (6)$$

This simple theory was proved in MiniCan 4 by using a HP4194A Impedance Analyzer to plot the electrical Admittance-Phase and get the resonances of this hydrophone, the results were different by 0.4 %, as we will see later in Chapter V.

## B. FET PREAMPLIFIER

The basic design of the preamp used by the NPS student Stavros Polydorou in the former constructed hydrophones appears in the figure below:

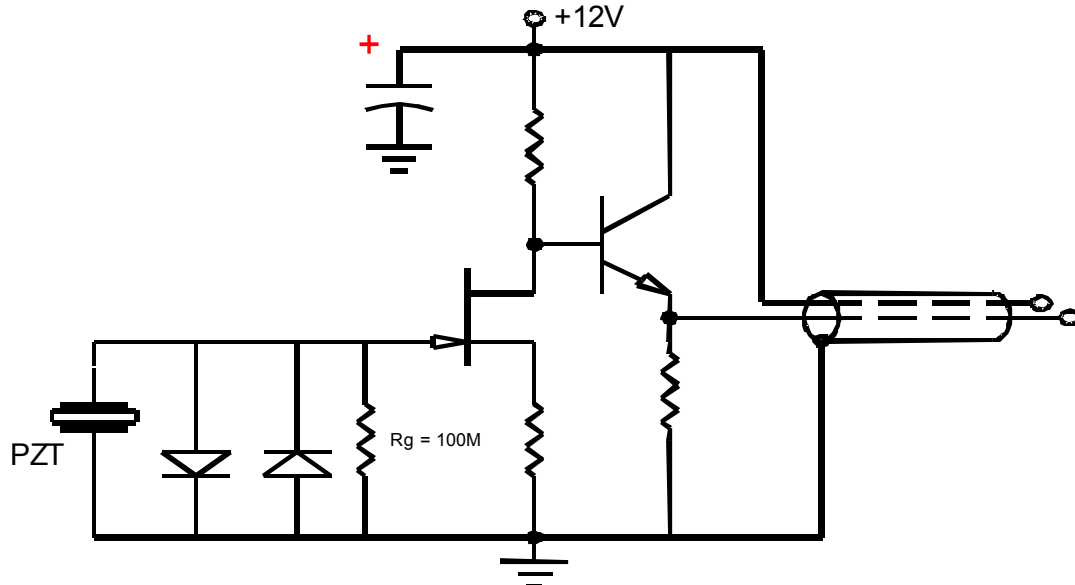

Figure 4. “A simple 2-stage, single-ended JFET preamp”.<sup>8</sup>

This preamp has a single-ended input and output and consists of a “simple n-channel JFET front end, followed by an NPN emitter follower stage that provides a low output impedance”.<sup>8</sup> The term JFET stands for **junction-gate field effect transistor**, meaning that the gate of this transistor is forming a pn junction with the substrate, and its operation relies on the electric field generated by the input voltage and not by the input current. The bias current at the JFET gate is typically less than 1 pA, and hence the input noise current is usually negligible.

The described preamp relied on a pair of diodes to protect the gate from the high fluctuating voltages generated by rough handling of the transducer, and the function of the 100-M $\Omega$  resistor was to maintain a gate DC bias voltage close to ground potential. The gain of the first JFET stage of the preamp can be as high as 30 and the gain of the second NPN stage is always unity.

This preamp had a low self-noise (1.67 nV/ $\sqrt{\text{Hz}}$  at 1 KHz), a voltage gain of 18.7 or 25.4 dB, and an input capacitance of 95 pF. The noise performance is excellent, but other problems and limitations are limited input voltage range, limited output current and high input capacitance.

<sup>8</sup> Stavros Polydorou, *A compact and inexpensive Hydrophone Having Ultra Low Self-Noise*, NPS thesis, 2002, figure 8, p. 26.

Due to the characteristic operation of the JFET amplifier the range of the input voltages at the gate is limited to zero or negatives values<sup>9</sup> with respect to the source lead. Higher values for the JFET's  $I_{DSS}$  (in the order of 4 mA) were used in the constructed preamps, which increase the maximum, undistorted input voltages.

The high value input or gate resistor was chosen to be as large as possible without causing significant DC offset arising from the gate bias current. Also, this resistor should not generate noise levels much higher than the Johnson noise level and be as small and economical as possible.

Smaller hydrophones with lower values of capacitance for the PZT material require a reduced input capacitance for the preamp. Otherwise several dB of transduction sensitivity will be lost to a preamp input capacitance as high as 95 pF.

Further attempts to improve the performance of the basic preamp design yields to the construction of a preamplifier with overall negative feedback. This feedback preamp has proven characteristics of improved linearity, input range, output current, output impedance and gain stability. This new preamp also presents a drastic reduction in the input capacitance and impedance. The design of this preamp was developed by Professor Tom Hofler from the NPS Physics Department and the schematics shown in the figure below:

---

<sup>9</sup> Neil Storey, *Electronics A Systems Approach*, Second Edition, Addison-Wesley, 1998, Fig. 6.15, p.195.

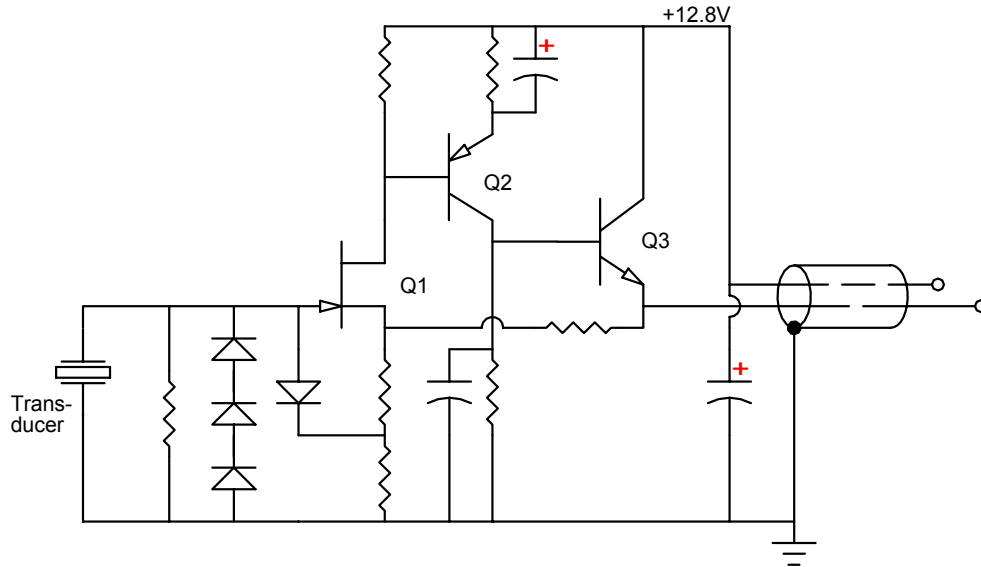

Figure 5. Schematics of the feedback preamp

The preamp illustrated above consists of an n-channel JFET front end (Q1), followed by a PNP transistor (Q2) on the second stage and NPN emitter follower (Q3) at the last stage to provide low output impedance. The problem of high input impedance was solved by using feedback from the output of the preamp to the source terminal of the JFET and resulting in a reduction of the capacitance of the whole preamp by more than a factor of 10 compared to the value of 95 pF for the first preamp.

THIS PAGE INTENTIONALLY LEFT BLANK

### III. HYDROPHONES CONSTRUCTED

#### A. MINICAN 3

LTJG Phuwadol Siripong (Thailand Navy) and ENS Douglas MacLean (US Navy) built this unit as a final project for the PH4454 transducer course. The metallic parts were made of Aluminum 6061 with a nominal diameter of 0.550" (13.97 mm). An internal circular step rising from the floor of a diameter slightly smaller than that of the PZT stack was machined to increase the receiving sensitivity. The sensing elements were American Piezo Ceramics 840<sup>10</sup> (APC-840), or PZT-4 of dimensions 0.260" diameter x 0.135" thickness or 6.6 mm diameter x 3.43 mm thickness.

During the process of gluing the ceramics to the copper foil was used the 2-part epoxy Emerson & Cummings 1266 and small amount of silver solder powder. This unit has an internal 2-stage flexible preamp with a pair of diodes acting both as voltage limiters for JFET protection and as the high value input or gate resistor.

A two-conductor plus shield cable, Belden 9452, with a 5.50 m length was used. One end of this cable was terminated with a Switchcraft Tini QG three-pin hydrophone cable connector.

A 2-part urethane Devcon Flexane 94 was used for encapsulating this unit.

The main characteristics found in MiniCan 3 are listed in the table below:

Outer diameter of the lid	13.82	mm
Interior diameter of the base	14.17	mm
Gap between base & lid	0.18	mm
Area ratio between average diameter & PZT	4.50	
Mass of the lid & ground cable	0.46	g
Mass of the base	1.14	g
Capacitance of the PZT stack	298	pF

<sup>10</sup> APC International Ltd., *Physical and Piezoelectric Properties of APCI Materials*. Available [online] at [http://www.americanpiezo.com/materials/apc\\_properties.html](http://www.americanpiezo.com/materials/apc_properties.html), 10/29/2003.

Gain of the built-in flexible preamp	15.51	dB
Capacitance of the internal preamp	40	pF
Theoretical sensitivity	-188.20	dB re 1 V/ $\mu$ Pa
Underwater Measured Pressure Sensitivity	-174.60	dB re 1 V/ $\mu$ Pa
Intrinsic Pressure Sensitivity (at preamp input)	-190.11	dB re 1 V/ $\mu$ Pa

Table 1. Main characteristics of MiniCan 3.

### B. MINICAN 4

This was the first unit in which the author of this thesis participated in the construction and testing. This unit was machined of Aluminum 6061-T6 with nominal diameter of 1”(25.4 mm) and has a novel interior machined feature to support the PZT stack.

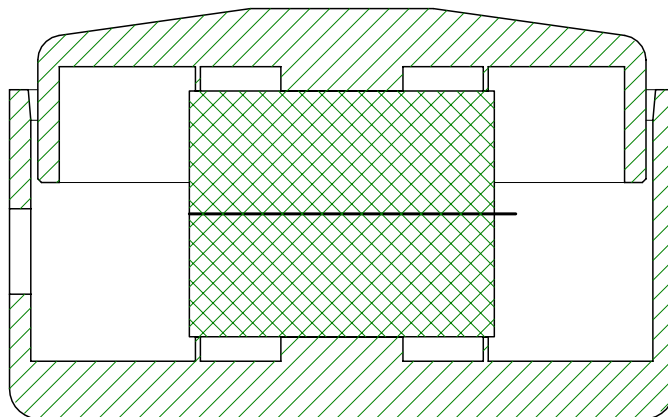

Figure 6. MiniCan design with radial stress reducing features machined into the aluminum parts.

The machined aluminum features shown in Fig. 6 are intended to allow unrestrained radial motion of the PZT and thereby increase the sensitivity. If this functions as intended, the measured sensitivity should match the simple theory given in equation (1) reasonably well.

The sensing elements of this transducer are 2 disks of material American Piezo Ceramics 840 (APC-840), or PZT-4 of dimensions 0.5” x 0.2” (12.7 mm x 5.08mm) for diameter and thickness respectively. This material corresponds to Navy Type I PZT

material. The 2 PZT parts were glued together with the polarization vector<sup>11</sup> pointing inward towards a 50 $\mu$ m copper foil between them. Gluing the PZT disks to the copper foil and to the surfaces of the base and lid is performed with a 2-part epoxy Emerson & Cummings 1266 with a proportion in weight of 100:28.

Because this transducer does not have a built-in preamp the output of the PZT stack was connected to the central wire of a 2.55 m long Alpha Wire RG-174 coaxial cable. The shielding wire of this coaxial cable was grounded to the bottom of the aluminum base, as well as the ground wire of the lid, using two 080 x 0.062" Allen screws, since these top and bottom parts form an electrical grounding surface for the PZT material. A BNC connector was installed on the other end of the coaxial cable.

A small package of desiccant, less than 50 mg, was deposited inside the unit to lower the humidity of the interior. At this point in the assembly process it is a good idea to test the function of the PZT stack, its electrode contacts, and the preamp wiring as a whole force sensing system, since repairs are still relatively simple. The test involves powering the preamp, connecting the output to an oscilloscope, and gently tapping the lid with either the hard or soft end of cotton tipped applicator stick. If the sensitivity of the hydrophone is high enough, whistling or finger snapping is also a reasonable test.

To seal the 0.30 mm gap between the interior diameter of the base and the outer diameter of the lid, a 2-part GE Silicon rubber RTV615 was used. This mixture has a proportion in weight of 100:10 and has a low mixed viscosity. Once mixed and vacuum degassed, it is allowed to rest for about 1 hour at room temperature (24° C) before apply it in order to make it more viscous and less likely to drip out of the gap.

Before potting or encapsulating this unit, 6 small wedges of completely cured Devcon Flexane 80 material, were glued with the 2-part epoxy Devcon Flexane 80, in each half of the MiniCan 4 with the purpose of keeping it aligned into a half of a wax mold machined on a CNC milling machine for this particular transducer.

Devcon Flexane 80, having a proportion in weight of 73:27 for parts A and B respectively was mixed with Flexane Flex-add to make the cured material softer. The

---

<sup>11</sup> The marked black dots on the electrodes of the APC-840 material were both contacting the copper foil.

mixture was put in a vacuum chamber to remove the air bubbles. The mixture was poured into the wax mold and the transducer was carefully inserted without trapping air bubbles.

Outer diameter of the lid	25.38	mm
Interior diameter of the base	25.91	mm
Gap between base & lid	0.26	mm
Area ratio between average diameter & PZT	4.08	
Mass of the lid & ground screw	3.72	g
Mass of the base & 2 PZT stack	16.63	g
Mass of the finished assembly	69.80	g
Capacitance of the PZT stack	874.20	pF
Capacitance of the coaxial cable & BNC	267.90	pF
Capacitance of the finished unit	1142.10	pF
Theoretical sensitivity + cable attenuation	-188.16	dB re 1 V/ $\mu$ Pa
Sensitivity using the Reference Accelerometer	-188.53	dB re 1 V/ $\mu$ Pa
Underwater Measured Pressure Sensitivity	-189.80	dB re 1 V/ $\mu$ Pa

Table 2. Main characteristics of MiniCan 4

### C. MINICAN 5

This unit is similar in design and dimensions to MiniCan 2 built by Polydorou and shown in Fig. 1. The differences are in the type of PZT used (APC 840 or Navy Type I), the input components of the flexible preamp, and the details of assembly. During the process of gluing the ceramics to the copper foil and to the aluminum housing, the 2-part epoxy Emerson & Cummings 1266 epoxy was used without the silver solder powder.

Since this unit was preamplified, the output of the PZT stack was connected to the input of a 2-stage flexible preamp with a 200 M $\Omega$  gate resistor of formed by two 100 M $\Omega$  resistors connected in series and glued to the bottom of the base using 5-minute epoxy.

A shielded two-conductor cable Belden 9452 of 5.15 m length was used to connect the output of the internal preamp at one end. On the other end of this cable was soldered a Switchcraft Tini QG three-pin hydrophone cable connector, wired according to the following diagram

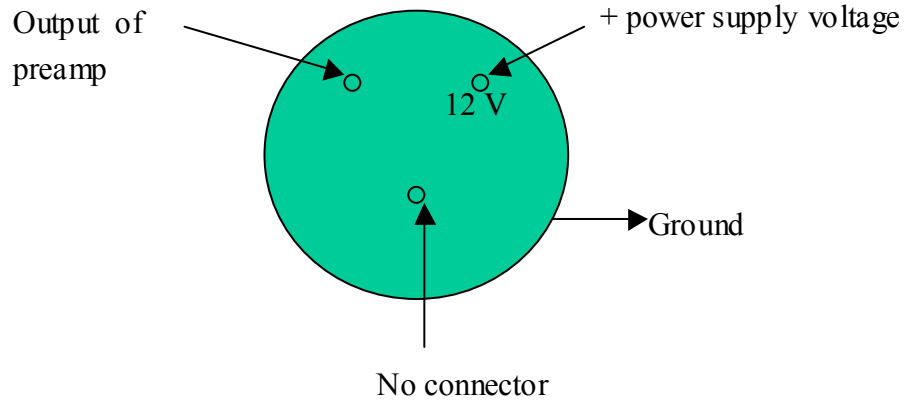

Figure 7. Backside of the Switchcraft Tini QG three pin connector.

Also, a 27 x 35 x 57 mm aluminum junction box with a three-pin connector jack, DC power jack and a BNC output connector was used to couple this preamplified unit to other measurement electronics.

Before closing the transducer a small package of desiccant was put inside, and the performance checked by the same procedure described in MiniCan 4. Likewise, the same 2-part silicon rubber and urethane were used to seal the gap between base and lid, and to pot the unit.

Outer diameter of the lid	25.30	mm
Interior diameter of the base	25.90	mm
Gap between base & lid	0.30	mm
Area ratio between average diameter & PZT	4.09	
Mass of the lid with ground cable	4.13	g
Mass of the base, 2 PZT stack & electronic comp.	17.42	g

Mass of the finished assembly	125.40	g
Capacitance of the PZT stack	515	pF
Capacitance of the internal preamp	52.70	pF
Theoretical sensitivity	-185.35	dB re 1 V/ $\mu$ Pa
Sensitivity using the Reference Accelerometer	-185.32	dB re 1 V/ $\mu$ Pa
Underwater Measured Pressure Sensitivity	-171.07	dB re 1 V/ $\mu$ Pa

Table 3. Main characteristics of MiniCan 5.

#### D. MINICAN 6

This unit has a nominal diameter of 0.660" (16.76 mm) and was made using the same materials mentioned above, but the internal shape of the housing, where the PZT material rests, is no longer flat as before. Instead, a circular step rising from the bottom of diameter equal to that of the PZT was machined in order to reduce the constraint in the radial direction and consequently increase the sensitivity of the unit.

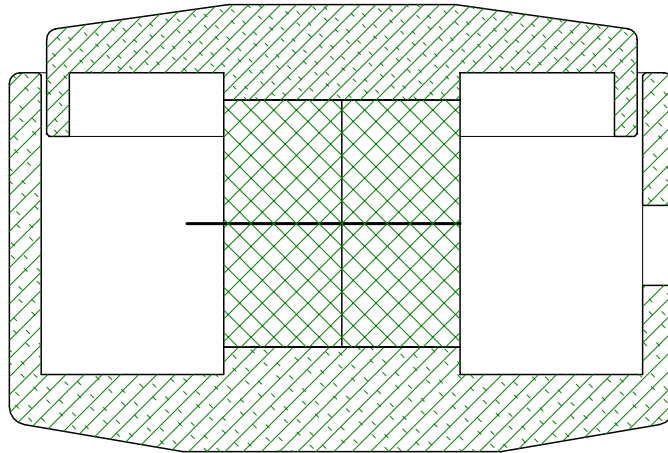

Figure 8. MiniCan design with an internal circular step to reduce the radial constraints.

The material of the sensing elements is again American Piezo Ceramics 840 (APC-840), or Navy Type I with dimensions 0.260" x 0.135" (6.60 mm x 3.43 mm) for diameter and thickness respectively.

The ceramic was glued to the copper foil with 2-part epoxy Emerson & Cummings 1266 alone. However, to join the ends of the PZT material to the aluminum housing a small amount of silver solder powder was added to the epoxy. The ground wire was connected to the lid with the 2-part silver epoxy TRA-DUCT FS-339 whose proportion in weight is 100:6.8 for resin and hardener respectively. An approximate equal amount of silver epoxy was applied at the opposite side of the lid to balance the moving mass.

This unit has an internal 2-stage flexible preamp with a very small high quality gate resistor of 1 G $\Omega$ . Due to the complexity of handling the wires in this reduced space, this preamp was glued to the walls using 5-minute epoxy.

A shielded two-conductor cable Daburn 2678 of 4.55 m length was used. A 2-part amber urethane PR-1570 was used for encapsulating this unit in a proportion by weight of 25:100, accelerator to base respectively.

Outer diameter of the lid	16.54	mm
Interior diameter of the base	16.88	mm
Gap between base & lid	0.17	mm
Area ratio between average diameter & PZT	6.27	
Mass of the lid & ground cable	1.19	g
Mass of the base, 2 PZT stack & electronic comp.	4.55	g
Mass of the finished assembly	63.65	g
Capacitance of the PZT stack	200.	pF
Capacitance of the built-in flexible preamp	51.4	pF
Gain of the built-in flexible preamp	18.03	dB
Theoretical sensitivity	-184.96	dB re 1 V/ $\mu$ Pa
Underwater Measured Pressure Sensitivity	-185.80	dB re 1 V/ $\mu$ Pa

Table 4. Main characteristics of MiniCan 6.

THIS PAGE INTENTIONALLY LEFT BLANK

## IV MEASUREMENT METHODOLOGY

### A. PREAMP MEASUREMENTS

The main measurements that were performed on the preamps were the gain, frequency response, and equivalent input noise voltage spectral density using different input capacitances to check the performance.

The preamp was fixed to a rigid board inside an aluminum box of dimensions 57mm x 57mm x 100mm. This box has two functions. The first function is to provide the necessary connectors for the power source (battery)<sup>12</sup>, and input and output signals as well. The second one is to provide electrical shielding for the measured preamp.

The frequency response measurements were made using the Stanford Research Systems Dynamic Signal Analyzer SRS785, which was set up in Swept-Sine measurement mode and used a frequency span of 1 Hz to 50 KHz. Two different types of input configurations were typically used during frequency response testing. First, the function generator source output of the SR785 was either directly connected to the input gate of the preamp, or was coupled to the gate with a large value plastic film capacitor and a 100 MΩ metal film gate resistor connected to ground. The second input configuration also used a plastic film capacitor and the 100 MΩ gate resistor, but with a capacitor value of approximately 50 pF. The difference in voltage gain measurement between the effectively zero source impedance and the 50 pF source impedance allows the effective input capacitance of the preamp to be measured.

The values of these measurements were recorded and compared to get the capacitance of the preamp, using the following formula:

$$C_P = \frac{1 - A_R}{A_R} C_C \quad (8)$$

Where  $A_R < 1$  corresponds to the ratio of the high source impedance gain to the low source impedance gain, and  $C_C$  is the coupling capacitance, and  $C_P$  is the input capacitance of the preamp.

<sup>12</sup> Lead Acid PANASONIC battery 12 V, 1.3 Ah.

The noise measurements on the constructed preamps were performed using the same equipment described before, but this time the dynamic Signal Analyzer SRS785 was set to measure the FFT power spectral density in dB re  $1V_{RMS}/\sqrt{Hz}$  at the output of the preamp with two different input configurations. In both cases no signal source was used. The first configuration is to short the preamp input to ground with zero impedance. In the second configuration, the source impedance of the PZT was simulated with a plastic film capacitor having a value that approximately matches that of the PZT at low frequencies. Also, a high value gate resistor was used that was the intended resistor for the final preamp configuration.

The shorted input noise measurements were initially taken with the electrical short placed at the aluminum box input connector. Later, it was discovered that if the short was placed directly on the small circuit board, the amount of 60 Hz power line interference, and its harmonics, were greatly reduced.

The noise measurements were divided into two frequency bands: a low frequency band, from 0-1.6 kHz, and mid-to-high frequency band from 128 Hz to 51 kHz. The results of these measurements will be displayed later in Chapter V.

## **B. MINICAN MEASUREMENTS**

Once the MiniCan hydrophone was complete, the performance of the unit was tested with an array of measurements. These include impedance measurements for the passive hydrophone, vibration and accelerometer sensitivity calibrations, anechoic chamber sensitivity calibrations, underwater tank comparison calibrations and self-noise in air for the active hydrophones as well.

The passive impedance measurements were just performed in MiniCan 4 since is the only un-amplified unit that can be excited by an electric voltage using the HP 4194A Impedance Analyzer. The data measured was the electrical Admittance for a frequency span of 100 Hz through 120 KHz. The MiniCan was placed on a soft foam rubber surface. The results of this measurement are useful when comparing the theory developed for the first resonance frequency of the MiniCan design, as we will see in the next chapter.

One uncommon method of obtaining the sensitivity of a hydrophone was using a reference accelerometer B&K Type 4294<sup>13</sup>, a B&K Mini Shaker type 4810<sup>14</sup> and two SR560<sup>15</sup> low-noise preamps with outputs connected to a SRS785 Dynamic Signal Analyzer. The Mini Shaker is mounted over two flat pieces of aluminum on a wooden table to reduce the environmental vibrations.



Figure 9. Photo of the arrangement used to obtain the Acceleration Sensitivity.

<sup>13</sup> The Specified Sensitivity of the Reference Accelerometer B&K Type 4294 at 159.2 Hz, 50 m/s<sup>2</sup> and 24.1°C is 0.1286 pC/ms<sup>2</sup> or 1.261 pC/g.

<sup>14</sup> The S/N of this device is 1878154.

<sup>15</sup> Stanford Research Systems Low-Noise Preamp, Model SR560, Input Capacitance 25 pF.

The Mini Shaker was driven by the SRS785, which also receives the output voltages generated by the reference accelerometer and MiniCan on channel 1 and 2 respectively. The frequency response was measured when precise masses of 0, 1, 2 and 5 grams were added on top of the MiniCan sensor. These responses were compared and the differences were used to calculate equivalent pressure response sensitivity based on the various acceleration sensitivities.

Another measurement performed on the constructed MiniCans was the calculation of the pressure sensitivity using the anechoic chamber facility at NPS. The method is a microphone comparison calibration and it was performed by comparing the received signal of the MiniCan and the received signal of a known and reliably calibrated microphone, which in this case was a condenser microphone B&K type 4133<sup>16</sup>. The output signal from this condenser microphone was amplified by a B&K Preamp type 2639<sup>17</sup> and sent it to Channel 1 on the Dynamic Signal Analyzer SRS785, which was set up for Swept-sine wave frequency response measurements. Likewise, the output signal from the MiniCan was amplified by a SR560 low-noise preamp, and sent it to Channel 2 on the SRS785. The sound source was a small boxed loudspeaker acting as an approximately omni directional sound source. These measurements were performed at frequencies less than 1 kHz to avoid the directional and diffractive effects of all of the transducers above 1 kHz.

Underwater comparison calibrations of the hydrophone pressure sensitivity were made in the water tank facility at NPS in order to check the performance of the constructed hydrophones. At low frequencies, the method used is similar to the one employed in the anechoic chamber. The reference hydrophone in this case was the B&K type 8103<sup>18</sup>, which has a very flat frequency response up to 45 kHz. The sound source for the low frequency calibrations was a Dual Tri-Laminar Flexural Disk Projector

---

<sup>16</sup> The size of this condenser microphone is ½” and has a Specified Pressure Sensitivity of -38 dB re 1V/Pa, or 12.6 mV/Pa. S/N 1854498.

<sup>17</sup> The S/N of this device is 1528067

<sup>18</sup> The reference Pressure sensitivity of this hydrophone is -211.7 dB re 1 V/μPa. S/N 2241680.

(DTLFDP)<sup>19</sup>, with a resonance frequency in water of 1150 Hz and driven by the Dynamic Signal Analyzer set up for Swept-sine frequency response measurements from 100 Hz to 1 kHz. The reference hydrophone is placed very close to the hydrophone under test and so the resulting sensitivity is purely an open-circuit voltage response to a known pressure. This is typically referred to as OCV sensitivity, and does not include physical diffraction effects or acoustic field effects that may arise with very compliant hydrophones. Below a frequency of 1 kHz, diffraction effects for the small transducers studied here should be negligible.

Mid to high frequency underwater measurements of pressure sensitivity were performed using an impulse-FFT method so as to eliminate the effect of an acoustically reverberant water tank. A SRS Synthesized Function Generator<sup>20</sup> is used to drive a spherical ITC-1032 transducer<sup>21</sup> having a resonance frequency in water of 33 kHz. Typically, a small power amplifier and a voltage step-up transformer amplified the function generator signal. This omni directional source was driven by a 2 kHz 1 cycle sine wave, and 13.2, 15, 18 kHz single square pulses.

The SR785 analyzer performed an FFT frequency response measurement and was usually set for a frequency span from 0 Hz up to 25.6 kHz or 0 Hz to 51.2 kHz with 100 FFT lines or bins in both cases. This allowed FFT time records that were a few milliseconds in duration. With judicious choice of delayed triggering intervals, the signals arising from acoustic waves reflected from the surfaces of the water tank were eliminated from the time record.

In this calibration method, a distance sufficient to ensure little interaction with each other via acoustic scattering separates the two-hydrophone receivers. Thus the hydrophone under test is being compared against a known “free acoustic field” assuming that the sound source is truly omni directional. This sort of calibration is usually called a “free field voltage sensitivity” or FFVS.

---

<sup>19</sup> LT Steve Rumph, LT Rob Hill and Eng Adam Akif constructed this projector as a final project on the PH4454 course.

<sup>20</sup> Stanford Research Systems, Function generator Model DS345, 30 MHz, S/N 18709.

<sup>21</sup> International Transducer Corporation Projector, Omni directional up to 45 KHz, Model 1032 and S/N 1097.

Another important measurement made on the constructed hydrophones was the measurement of the hydrophone self-noise in air of the preamplified units acting as a whole. The measurements were performed in the anechoic chamber facility at NPS because of the room's quietness. The hydrophone being measured was mounted on a mechanical filter composed of a square cross-section solid steel bar, (mass  $\cong$  2 kg) suspended by 2 rubber bands, one at each end, to reduce the environmental vibrations. This mechanical filter has a natural frequency of 0.75 Hz.

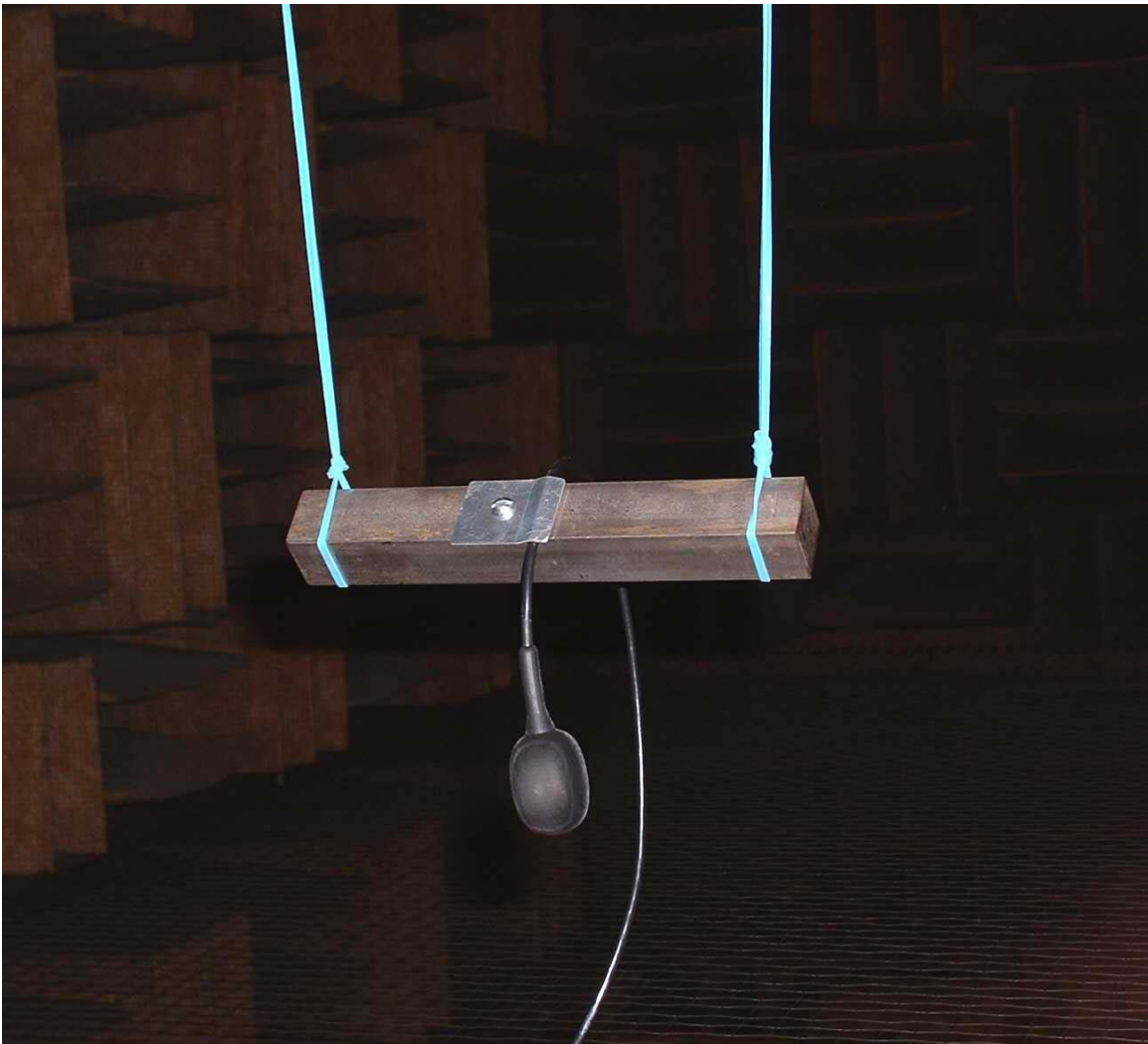

Figure 10. Photo of the mechanical filter used to reduce the noise due to environmental vibrations with mounted hydrophone under test.

In this measurement there wasn't any sound source in the anechoic chamber except for the environmental noise, but taking the measurements late at night when the noise in the building is a minimum reduced even this. The output of the MiniCan was connected to a SR560 Low-Noise Preamp running on batteries to eliminate the 60 Hz harmonics in the measurements.

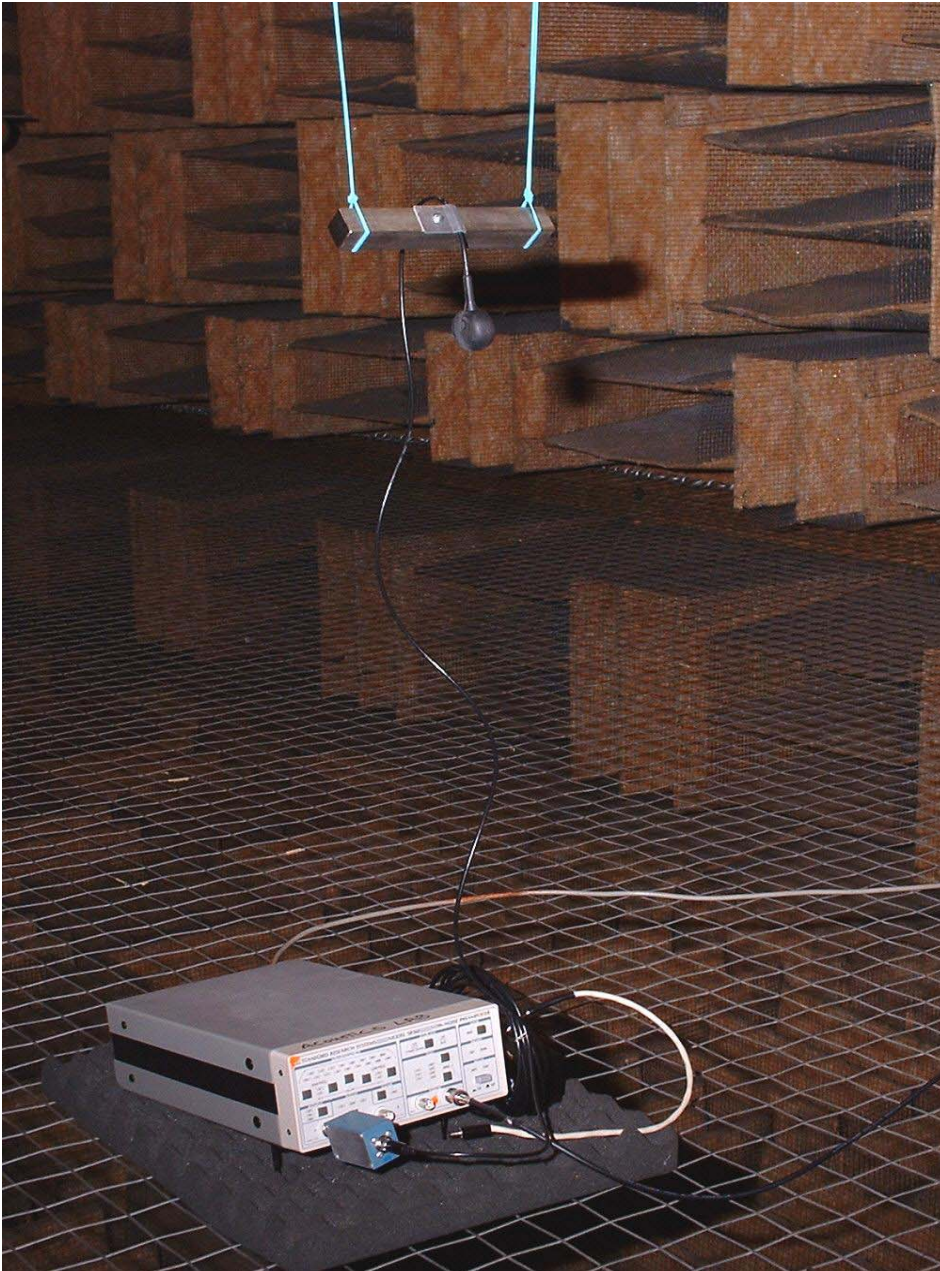

Figure 11. Schematics of the whole systems to measure the self-noise of the hydrophone.

The preamplified signal from the SR560 was sent to Channel 2 on the SRS785 dynamic signal analyzer to measure noise power spectral density in dB re  $1V_{\text{RMS}}/\sqrt{\text{Hz}}$ .

## V. RESULTS AND DISCUSSION

### A. PREAMP MEASUREMENTS

The voltage gain frequency response of the flexible preamp is very flat over the entire frequency band of interest, except for the lower frequency limit created by the capacitance of the PZT and the high value input gate resistor. For example, MiniCan 6 has a source capacitance of 200 pF, which creates a high pass filter when combined with the 1 G $\Omega$  gate resistor. The -3 dB cutoff frequency for this particular filter is then  $f_0 = 0.8$  Hz.

The results of the self-noise measurements on the flexible preamps built-in in MiniCans 5 and 6 with zero source impedance, that means just the noise of the electronic components is present are shown in the following figures:

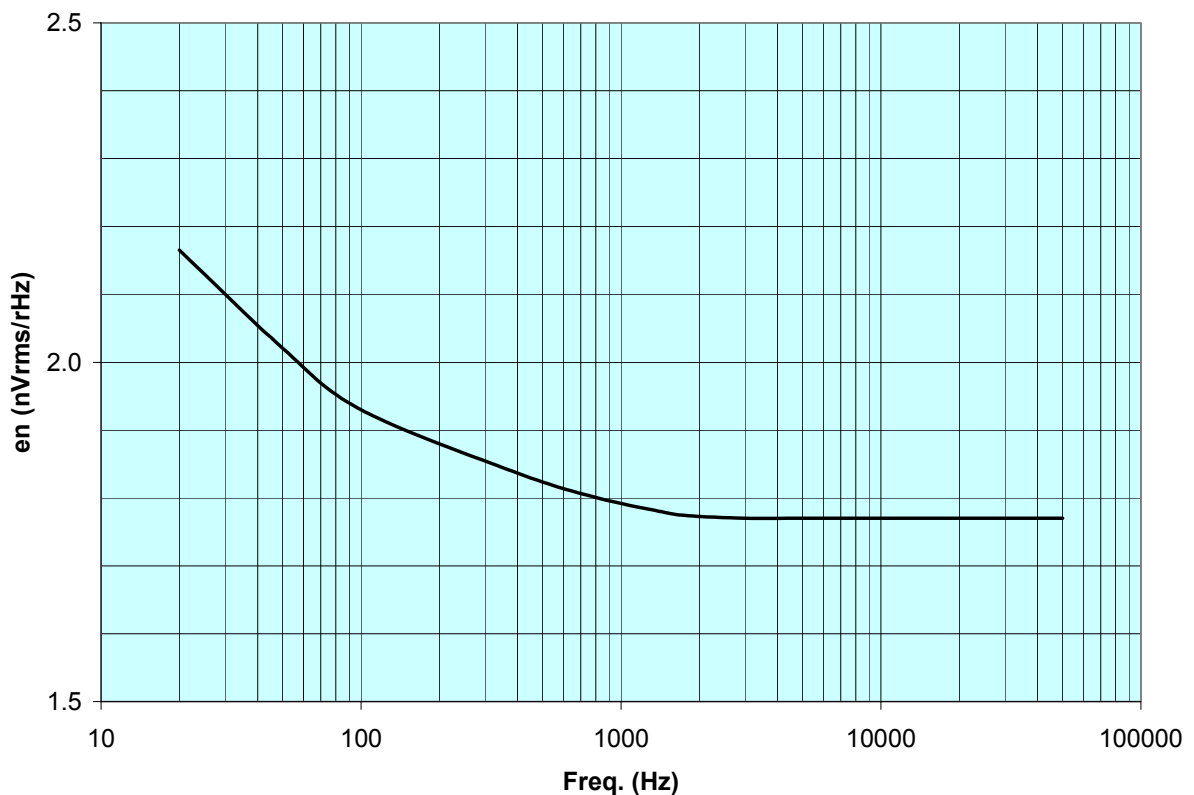

Figure 12. Equivalent Input Noise in nV/ $\sqrt{\text{Hz}}$  of the flexible preamp used in MiniCan 5 with zero source impedance.

From the figure above we see the usual 1/f amplifier characteristic, however above 100 Hz the noise of the JFET circuit is low and it becomes approximately constant above 1 kHz, having an average value up to 50 KHz of 1.78 nV/ $\sqrt{\text{Hz}}$ .

The noise measurement for MiniCan 6 is shown below and is relatively constant from 200 Hz and up to 50 KHz with an average value of 1.75 nV/ $\sqrt{\text{Hz}}$ .

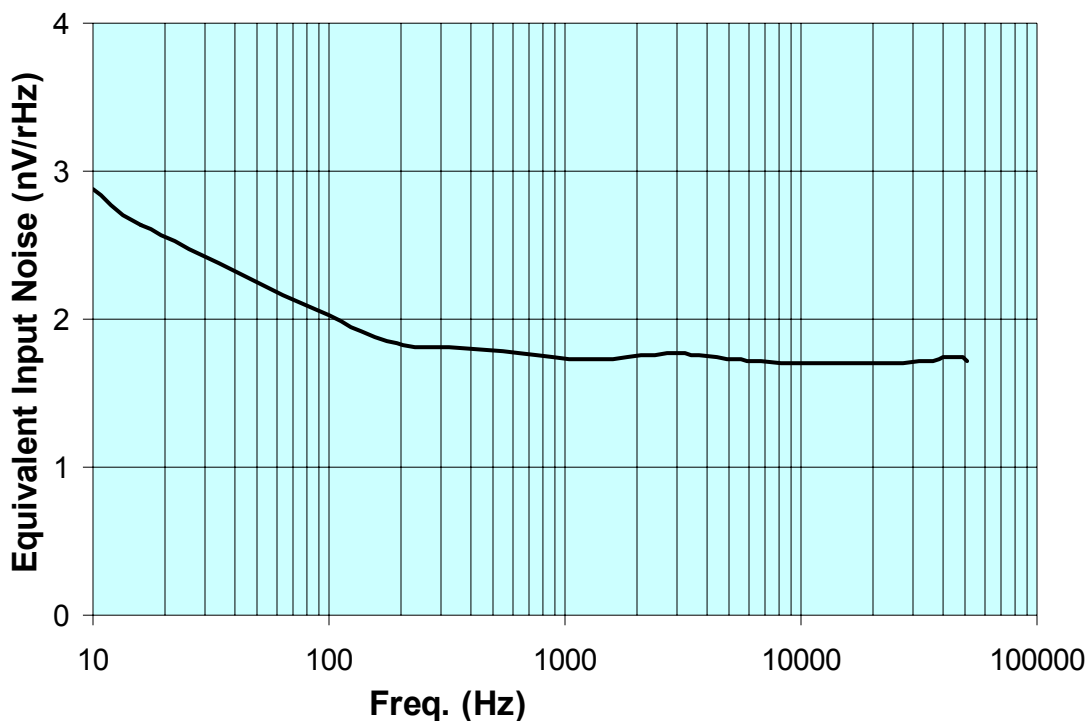

Figure 13. Equivalent input noise of the flexible preamp used in MiniCan 6 with zero source impedance.

While the preamplifier noise data shown above is exceedingly low, the noise performance of the preamp is considerably different when its input is coupled to passive impedance that approximates that of the hydrophone. For example, to simulate the noise performance of MiniCan 5 a parallel combination of a 548 pF plastic film capacitor and a 200 M $\Omega$  metal film resistor was connected between the preamp input and ground. The resulting noise data is shown below in Fig. 13.

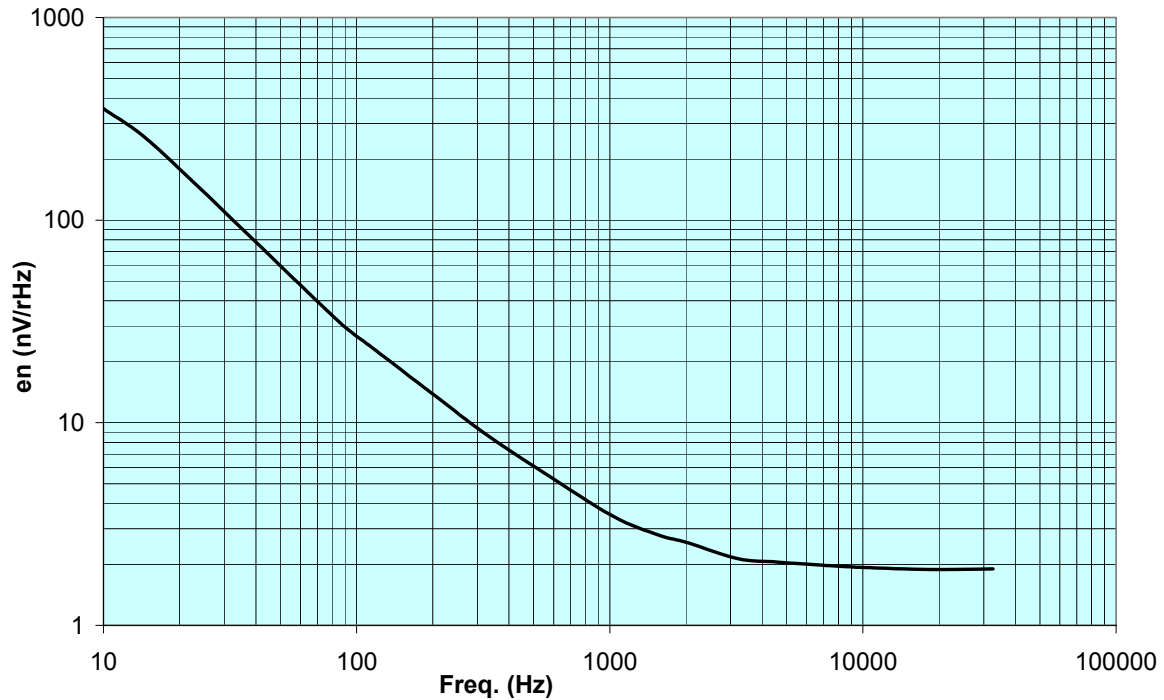

Figure 14. Equivalent input noise of preamplifier used in MiniCan 5 with simulated hydrophone source impedance.

## B. MINICAN MEASUREMENTS

The results of the passive impedance measurements for MiniCan 4 were important in order to check the theory developed for the first resonance frequency of the MiniCan design against real resonant values. The theoretical resonance was calculated using the derived formula:

$$f = \frac{\sqrt{Y_{33}}}{2\pi L} kL \quad (6)$$

Where the Young's modulus in the 3-direction for open circuit conditions (constant displacement field) is equal to the inverse of the elastic compliance  $Y_{33}^D = \frac{1}{S_{33}^D}$ <sup>22</sup>.

The value for the elastic compliance was taken from Table 4.3 of the cited reference. The

<sup>22</sup> Oscar Bryan Wilson, *Introduction to Theory and Design of Sonar Transducers*, Peninsula Publishing, 1988, Equation 3.21, p.52.

manufacturer gives a density value of  $7600 \text{ kg/m}^3$  for the PZT (APC-840) material<sup>23</sup>. The value obtained for  $kL$  was obtained by solving a transcendental equation by trial and error, and was found to be  $kL = 1.47$ .

The theory gives us a value of 93,420 Hz for the potted MiniCan in air, and the measured value for the second resonance using the impedance analyzer was 93,022 Hz, as shown in the figure below, these 2 values are within 0.4 percent of each other.

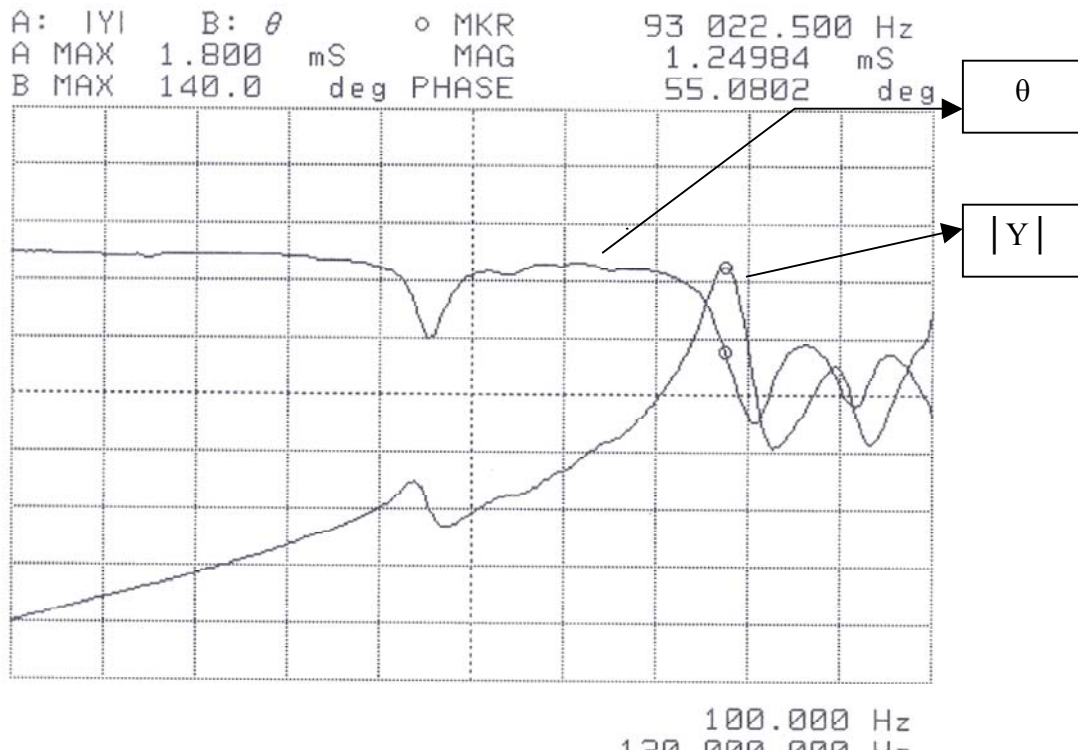

Figure 15. Plot of the electrical admittance (Y)- and phase ( $\theta$ ) of the potted MiniCan 4 in air using the HP4194A Impedance Analyzer..

The small resonance located at approximately 53 KHz we believe is due to a flexural mode for the lid or base of the MiniCan.

Inferring the pressure sensitivity of the MiniCans by comparing to a reference accelerometer while a shaker excites both yields the following results:

<sup>23</sup> APC International Ltd., *Physical and Piezoelectric Properties of APCI Materials*. Available [online] at [http://www.americanpiezo.com/materials/apc\\_properties.html](http://www.americanpiezo.com/materials/apc_properties.html), 10/29/2003.

Measurement	MiniCan 4 (dB re 1 V/μPa)	MiniCan 5 (dB re 1 V/μPa)
Pressure Sensitivity by simple theory	-185.65	-185.35
Pressure Sensitivity by reference accelerometer	-185.80	-184.22
Difference in dB re 1 V/ μPa	0.15	-1.13

These results show good agreement with the simple theory,

$$OCV_{PZT} = \left( \frac{A_{MC}}{A_{PZT}} \right) g_{33} t .$$

Moreover, the pressure sensitivity of MiniCan 4 was measured in air using the anechoic chamber and we obtained a low frequency sensitivity of  $-188.53$  dB re 1 V/μPa, which is 2.88 dB less than the obtained value by simple theory. This reduction in sensitivity could be due to the urethane encapsulating this unit, since the accelerometer-based measurements were performed with the un-potted MiniCan, and “the sensitivity of a hydrophone is the same in air as in water for low frequencies”<sup>24</sup>.

---

<sup>24</sup> Bruel & Kjaer, Available [online] at: <http://www.bk.dk>, p.4. 8/21/2003.

The combined results of the low frequency swept sinewave or OCV sensitivity, and the high frequency impulse sensitivity measurements or FFVS taken in the water tank facility at NPS gave us the following results for the constructed MiniCans:

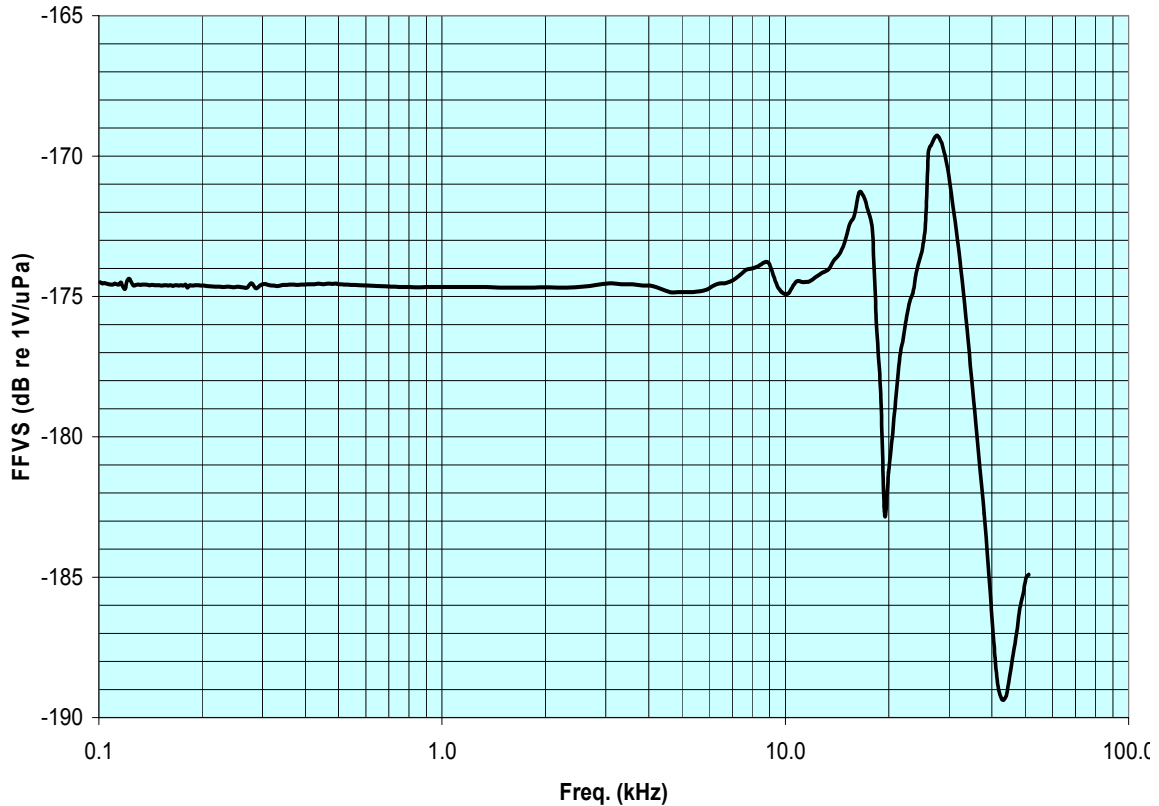

Figure 16. Free Field Voltage Sensitivity of MiniCan 3 using two different sound sources in two frequency ranges.

The low frequency sensitivity of this small MiniCan is  $-174.6$  dB re  $1$  V/ $\mu$ Pa and is flat up to 14 KHz.

The zero source impedance gain of the internal preamp is 15.51 dB with an input capacitance of 40 pF. The measured PZT source capacitance is 298 pF at low frequencies; so 1.09 dB of PZT signal will be lost to the preamp input capacitance. These gain and loss factors can be used to determine the intrinsic sensitivity of the PZT and MiniCan geometry, which is  $-189.0$  dB. Since the simple theory yields a pressure sensitivity of  $-188.2$  dB, the measured value is low by  $-0.8$  dB.

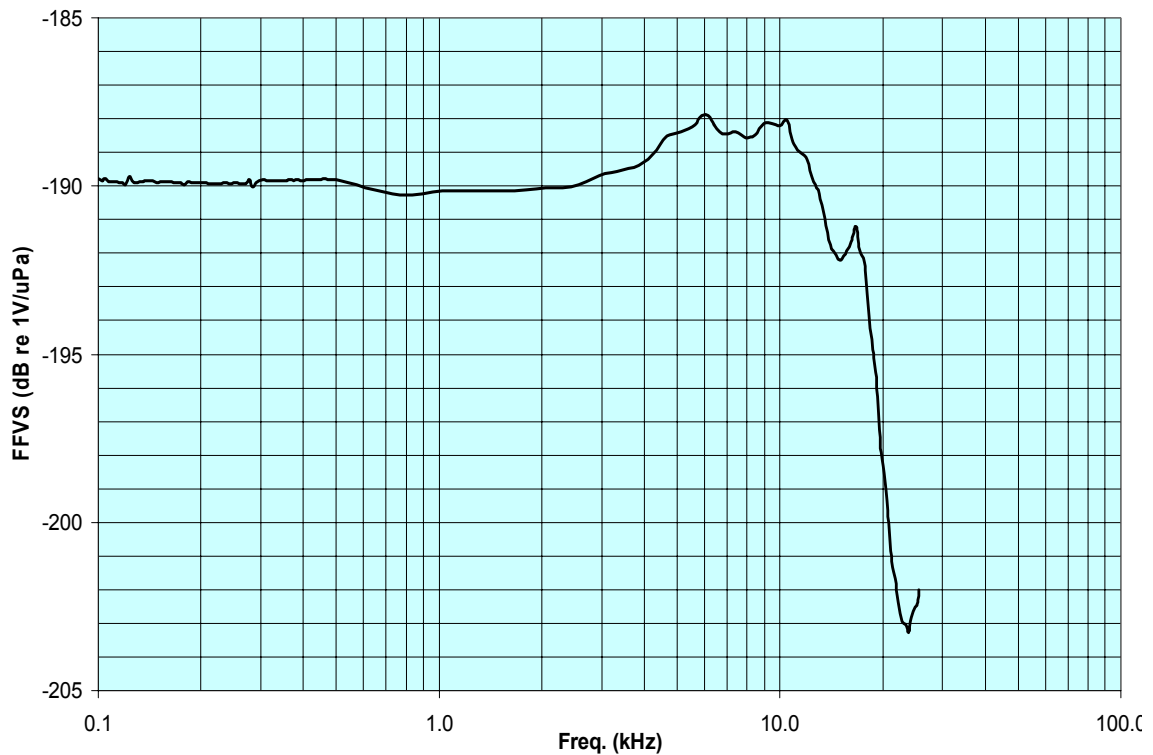

Figure 17. Free Field Voltage Sensitivity of MiniCan 4 using two different sound sources in two frequency ranges.

The low frequency sensitivity of this MiniCan is  $-189.8$  dB re  $1 \text{ V}/\mu\text{Pa}$  and is flat up to 13 kHz, although not quite as flat as MiniCan 3. This result is 1.64 dB less than the sensitivity value by simple theory but is around 22 dB higher than the B&K type 8103 used as reference. This is probably caused by the strain relieving aluminum features.

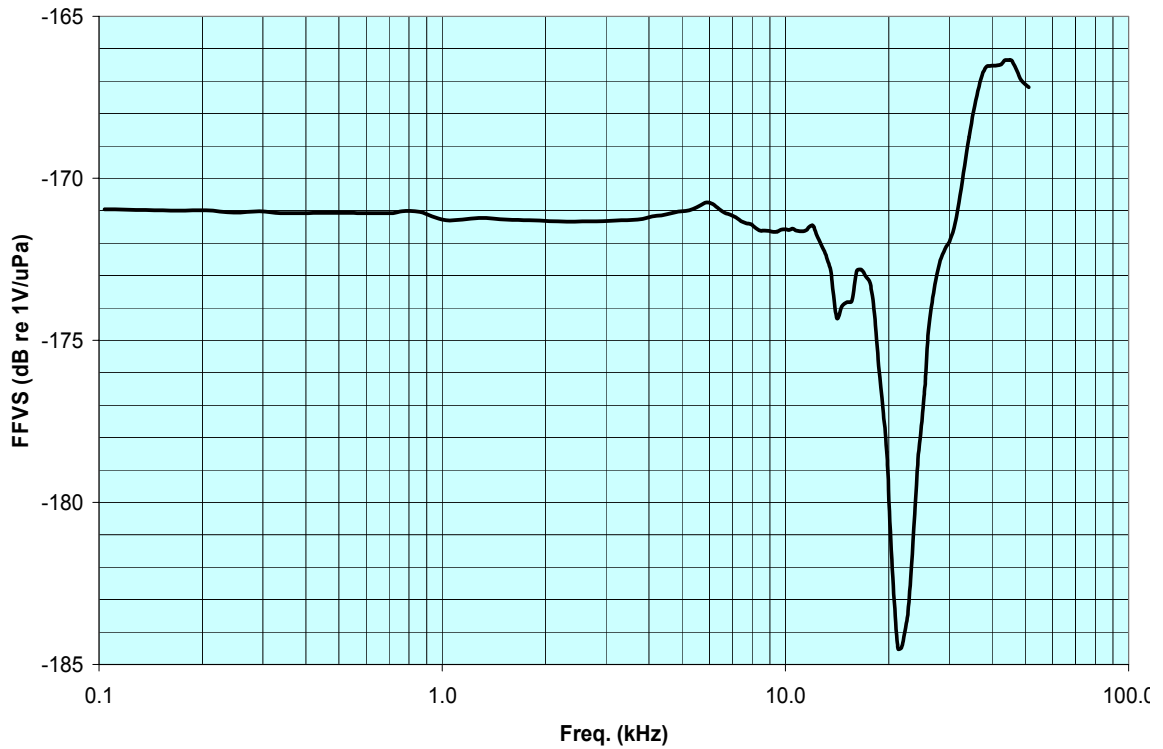

Figure 18. Free Field Voltage Sensitivity of MiniCan 5 using two different sound sources in two frequency ranges.

The low frequency sensitivity of MiniCan 5 is  $-171.0$  dB re  $1\text{V}/\mu\text{Pa}$  and is flat up to 12 kHz. The intrinsic sensitivity of MiniCan 5 (without preamplification) is  $-190.0$  dB re  $1\text{V}/\mu\text{Pa}$ . This value is 4.6 dB less than the obtained value by simple theory.

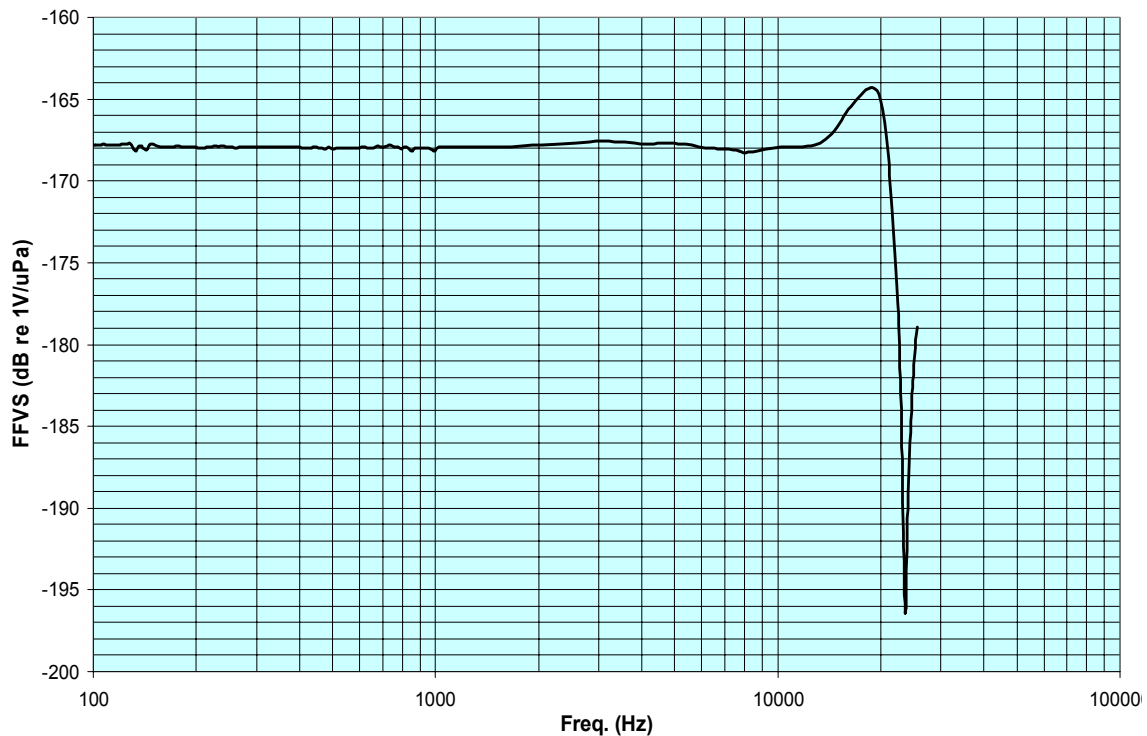

Figure 19. Free Field Voltage Sensitivity of MiniCan 6 using two different sound sources in two frequency ranges.

The low frequency sensitivity of MiniCan 6 is  $-168.0$  dB re  $1\text{V}/\mu\text{Pa}$  and is flat up to  $14$  kHz. An intrinsic sensitivity value of  $-185.8$  dB re  $1\text{V}/\mu\text{Pa}$  was obtained. This measured value is  $0.8$  dB less than the value from the simple theory. This good agreement between theory and measurement for the sensitivity is due to the fact that this design has an internal circular step rising from the bottom to support the PZT stacks and reduces the constraints of the PZT material in the radial direction.

### C. HYDROPHONE NOISE MEASUREMENTS

The self-noise measurement results for the MiniCans in the relatively quiet anechoic chamber facility at NPS were compared to the lowest underwater noise reference known as “Wenz’s minimum”. The “thermal noise” is a fundamental thermodynamic noise limit for water, which dominates above  $40$  kHz. The actual sensitivity measured at low frequencies of each MiniCan was used to generate the data

shown below. Likewise, noise performance comparisons with 2 very well known and expensive commercial preamplified hydrophones produce the following results:

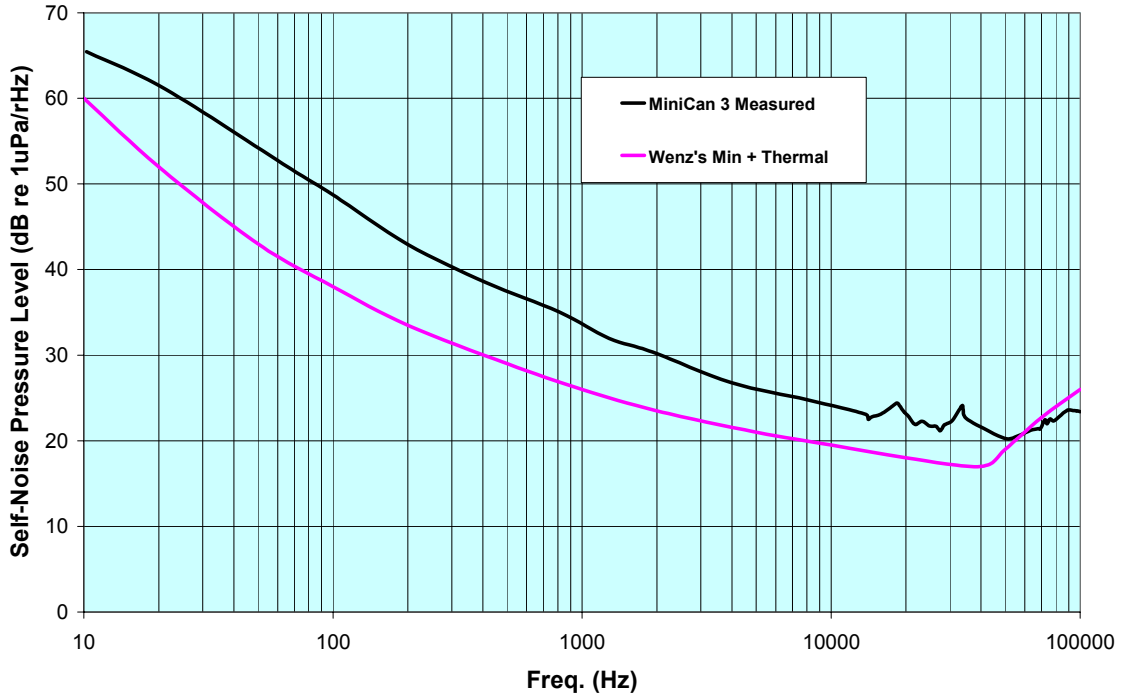

Figure 20. Self-Noise Pressure Level of MiniCan 3 in dB re  $1 \mu\text{Pa}/\sqrt{\text{Hz}}$  compared to Wenz's minimum plus thermal noise.

MiniCan 3 was below Knudsen sea-state zero but approximately 4 - 10 dB above the ocean noise level up to 40 kHz. This mediocre noise performance is caused by the lower sensitivity of the design (smaller area ratio in Eq. 1) and the fact that this transducer used the pair of protection diodes to act as a gate resistor also. The effective value of this diode based gate resistance is approximately 50 M $\Omega$  and rather variable, as well as too low for best noise performance.

We also see that some of the noise is mechanical in origin and is filtered by two natural vibrational modes at 18 and 34 kHz. While an internally preamplified hydrophone prevents the use of impedance analyzers to probe the electro-mechanical resonance characteristics, we can see that the use of an ultra-low-noise preamp allows the resonances and their noise to be revealed. Had the preamplifier noise floor been 10 dB

higher, as in the case of nearly all FET input op-amps, these resonant peaks would have been entirely obscured.

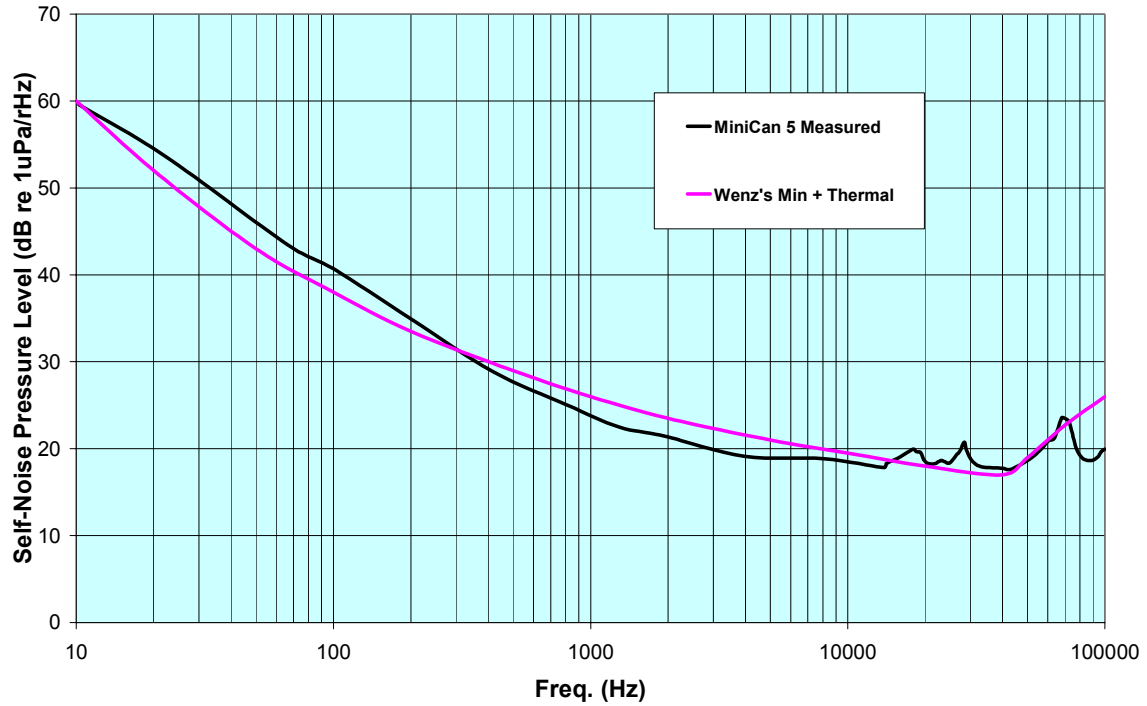

Figure 21. Self-Noise Pressure Level of MiniCan 5 in dB re 1  $\mu\text{Pa}/\sqrt{\text{Hz}}$  compared to Wenz's minimum plus thermal noise.

The noise level of MiniCan 5 is lower than the Wenz's minimum above 300 Hz and is filtered again by 3 natural modes at 18.4, 29 and 69 kHz. But it is from 0 to 9 dB lower than the best noise performance of the commercial hydrophones shown in the figure below, in the frequency range below 20 kHz.

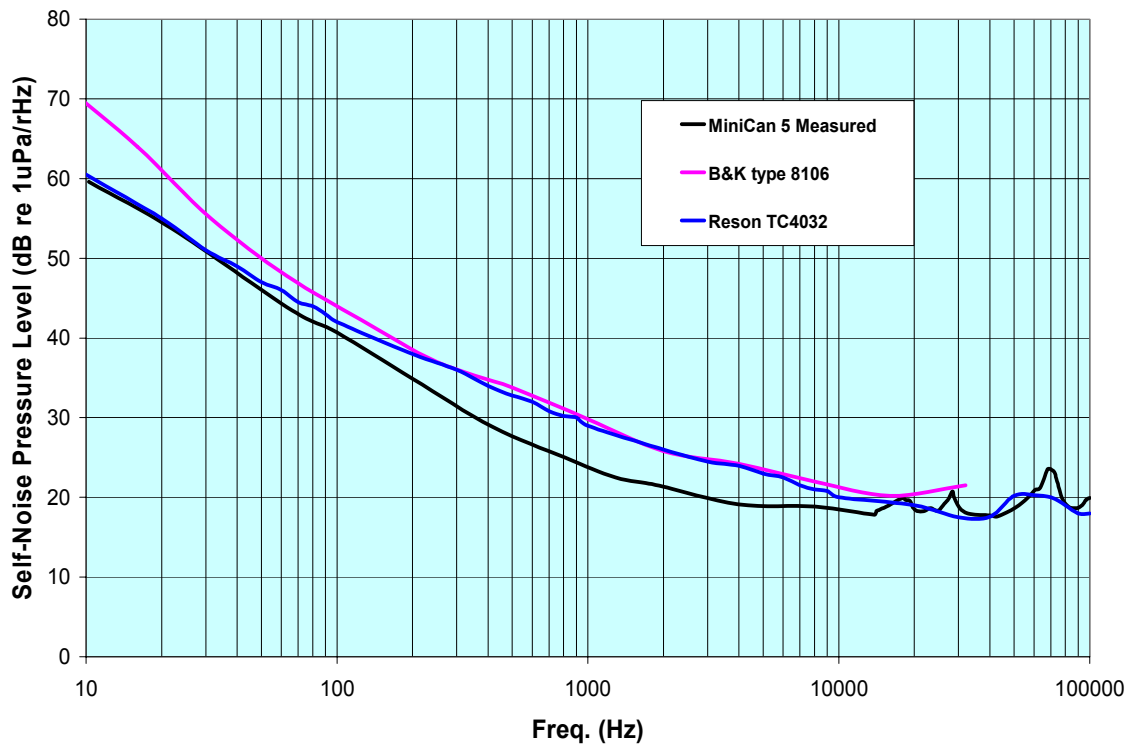

Figure 22. Self-Noise Pressure Level of MiniCan 5 in dB re 1  $\mu\text{Pa}/\sqrt{\text{Hz}}$  compared to two large and expensive commercial hydrophones.

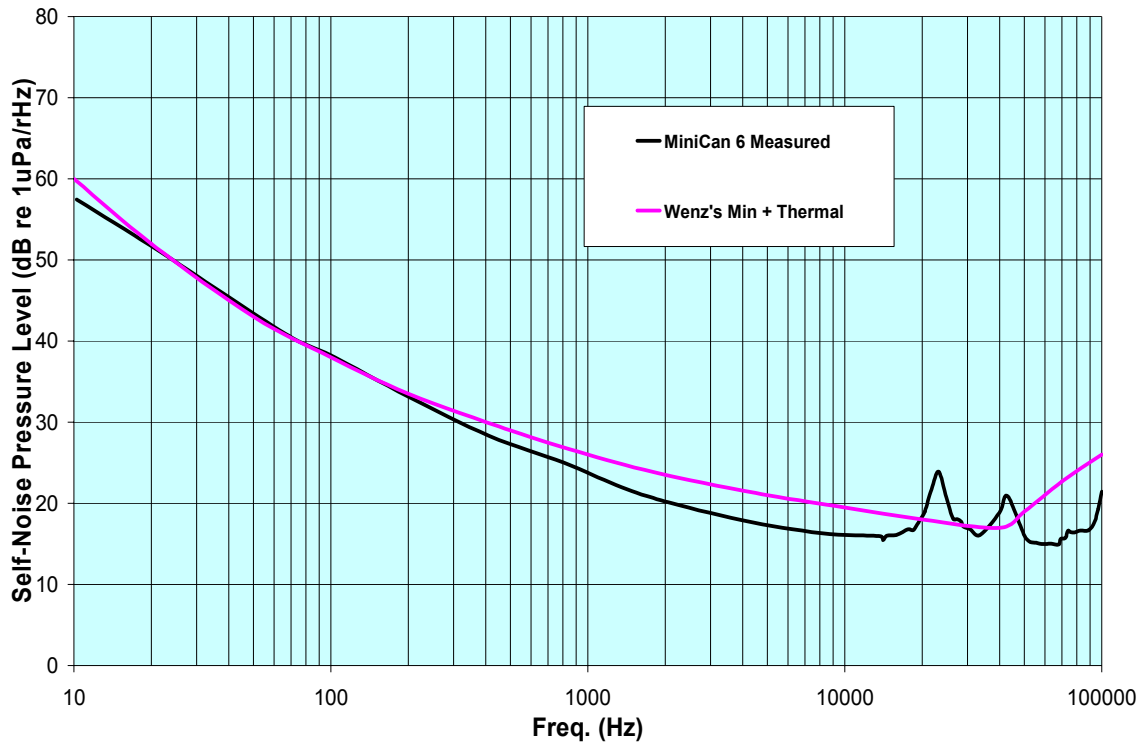

Figure 23. Self-Noise Pressure Level of MiniCan 6 dB re 1  $\mu\text{Pa}/\sqrt{\text{Hz}}$  compared to Wenz's minimum plus thermal noise.

The outstanding noise performance of MiniCan 6 matches and beats the Wenz's minimum noise level in the entire spectrum, except at the 2 natural modes. Consequently it is from 3 to 11 dB lower than the best noise performance of the compared commercial hydrophones.

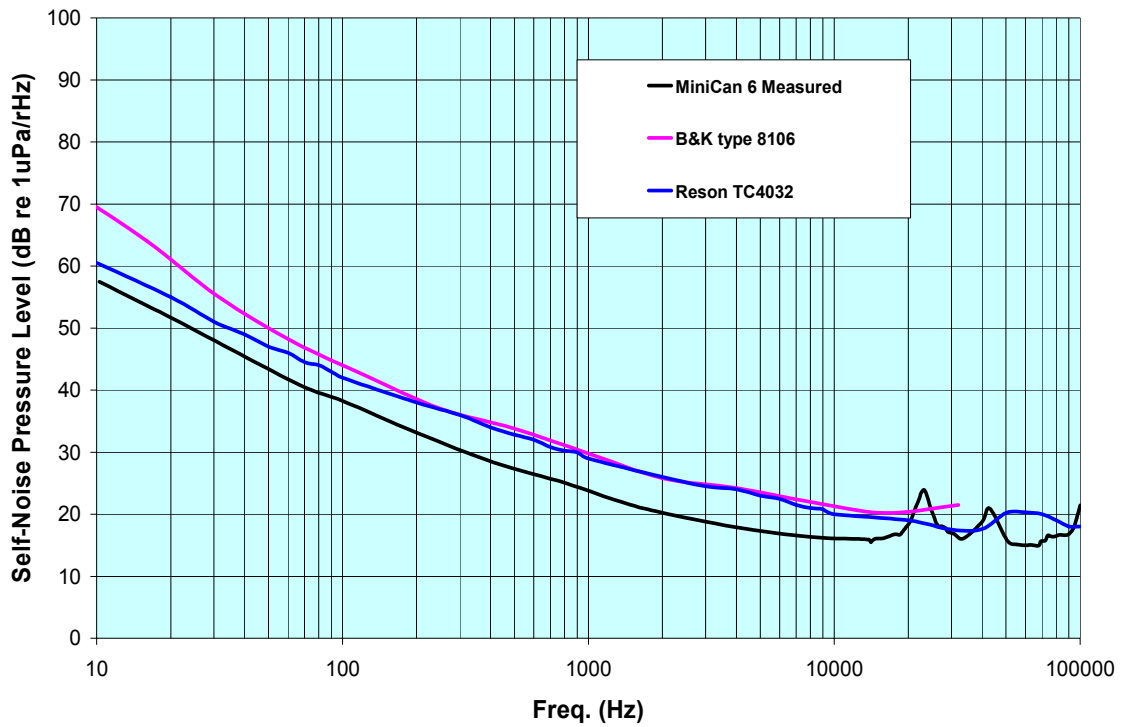

Figure 24. Self-Noise Pressure Level of MiniCan 6 in dB re  $1 \mu\text{Pa}/\sqrt{\text{Hz}}$  compared to two large and expensive commercial hydrophones.

## VI. CONCLUSIONS

From the experience and results obtained while building and testing the MiniCan hydrophones we can conclude that a nearly full sensitivity can be achieved compared to simple theory, by eliminating the hot soldering of the PZT and creating radial strain relief via the circular step bonding pad machined into the aluminum parts.

With full sensitivity and outstanding noise performance of the flex preamp (aided by the new surface mount high value Ohmcraft resistors), outstanding hydrophone self-noise is achieved in a very inexpensive and small package.

Flatness of response is outstanding in the human audibility frequency band, 20 Hz to 15 kHz. Furthermore, the response is also very flat well into the infrasonic frequency range, extending down 2 Hz. Achieving extended flat response above 14 or 15 kHz needs further work.

Reducing acceleration sensitivity needs further work.

THIS PAGE INTENTIONALLY LEFT BLANK

## LIST OF REFERENCES

1. Anan'eva Alevtina Aleksandrova, *Ceramic Acoustic Detectors*, translated from Russian, Consultants Bureau, New York, 1965.
2. American Piezo Ceramics International Ltd, *Physical and Piezoelectric Properties of APCI Materials*. Available [online] at [http://www.americanpiezo.com/materials/apc\\_properties.html](http://www.americanpiezo.com/materials/apc_properties.html), 10/29/2003
3. Bobber J. Robert, *Underwater Electroacoustics Measurements*, Naval Research Laboratory Underwater Sound Reference Division, Orlando, Florida, 1970.
4. Bruel & Kjaer Sound and Vibration Measurement Inc., hydrophones brochure, Available [online] at: <http://www.bk.dk>, 8/21/2003.
5. Hill Winfield, Horowitz Paul, *The Art of Electronics*, First Edition, Cambridge University Press, 1983.
6. Lawrence Kinsler E., Frey Austin R., Coppens Alan B., Sanders James V., *Fundamentals of Acoustics*, Fourth Edition, John Wiley & Sons, 2000.
7. Storey Neil, *Electronics A systems Approach*, Second Edition, Addison-Wesley Longman Ltd, 1998.
8. Urick Robert J., *Principles of Underwater Sound*, Third Edition, Peninsula Publishing Los Altos California, 1996.
9. Wenz Gordon M., *Acoustic Ambient Noise in the Ocean: Spectra and Sources*, J. Acoust. Soc. Am. 34, 1962.
10. Wilson Oscar Bryan, *Introduction to Theory and Design of Sonar Transducers*, Peninsula Publishing Los Altos California, 1988.

THIS PAGE INTENTIONALLY LEFT BLANK

## INITIAL DISTRIBUTION LIST

1. Defense Technical Information Center  
Ft. Belvoir, Virginia
2. Dudley Knox Library  
Naval Postgraduate School  
Monterey, California
3. Professor Thomas Hofler, Code PH/Hf  
Department of Physics  
Monterey, California
4. Professor Andres Larraza, Code PH/La  
Department of Physics  
Monterey, California
5. Chairman, Physics Department  
Naval Postgraduate School  
Monterey, California
6. Chair, Engineering Acoustics Academic Committee  
Naval Postgraduate School  
Monterey, California
7. Engineering & Technology Curricular Office (Code 34)  
Naval Postgraduate School  
Monterey, California
8. Mexican Navy General Staff  
Personnel and Training (B) Branch  
Mexico city, Mexico
9. LT Miguel Alvarado-Juarez  
Mexico city, Mexico