



**NAVAL
POSTGRADUATE
SCHOOL**

MONTEREY, CALIFORNIA

THESIS

**DESIGN AND OPTIMIZATION OF A HYPERSONIC TEST
FACILITY FOR SUBSCALE TESTING**

by

Stephen R. O'Kresik

December 2003

Thesis Advisor: Jose O. Sinibaldi
Second Reader: Garth V. Hobson

Approved for public release; distribution is unlimited

THIS PAGE INTENTIONALLY LEFT BLANK

REPORT DOCUMENTATION PAGE			Form Approved OMB No. 0704-0188
Public reporting burden for this collection of information is estimated to average 1 hour per response, including the time for reviewing instruction, searching existing data sources, gathering and maintaining the data needed, and completing and reviewing the collection of information. Send comments regarding this burden estimate or any other aspect of this collection of information, including suggestions for reducing this burden, to Washington headquarters Services, Directorate for Information Operations and Reports, 1215 Jefferson Davis Highway, Suite 1204, Arlington, VA 22202-4302, and to the Office of Management and Budget, Paperwork Reduction Project (0704-0188) Washington DC 20503.			
1. AGENCY USE ONLY (Leave blank)	2. REPORT DATE December 2003	3. REPORT TYPE AND DATES COVERED Master's Thesis	
4. TITLE AND SUBTITLE: Design and Optimization of a Hypersonic Test Facility for Sub-Scale Testing		5. FUNDING NUMBERS	
6. AUTHOR(S) Stephen O'Kresik, LT, USN		8. PERFORMING ORGANIZATION REPORT NUMBER	
7. PERFORMING ORGANIZATION NAME(S) AND ADDRESS(ES) Naval Postgraduate School Monterey, CA 93943-5000		10. SPONSORING/MONITORING AGENCY REPORT NUMBER	
9. SPONSORING /MONITORING AGENCY NAME(S) AND ADDRESS(ES) N/A		11. SUPPLEMENTARY NOTES The views expressed in this thesis are those of the author and do not reflect the official policy or position of the Department of Defense or the U.S. Government.	
12a. DISTRIBUTION / AVAILABILITY STATEMENT Approved for public release ;distribution is unlimited		12b. DISTRIBUTION CODE	
13. ABSTRACT (maximum 200 words) The Rocket Propulsion and Combustion Laboratory at the Naval Postgraduate School was evaluated to determine if the currently installed systems could support the operation of a subscale hypersonic test stand. Trait analysis of existing lab support sub-systems was performed and an envelope of operation, defined by flight altitude and flight Mach number was determined. Calculations revealed that if the air supply volume was doubled to 160 ft ³ , a hypersonic blow-down facility could generate conditions to perform testing in the dynamic pressure window of 500 to 2000 psf, from Mach 5 to 7.5 with a maximum system mass flow rate variation from 3 to 45 lbm/s. Additionally, a dynamic design process was outlined to assist other designers in producing similar test stands. Finally, a software analysis package was developed to analyze proposed changes in the support system architecture.			
14. SUBJECT TERMS Hypersonic test facilities, Hypersonic combustor testing, Trait analysis		15. NUMBER OF PAGES 87	
		16. PRICE CODE	
17. SECURITY CLASSIFICATION OF REPORT Unclassified	18. SECURITY CLASSIFICATION OF THIS PAGE Unclassified	19. SECURITY CLASSIFICATION OF ABSTRACT Unclassified	20. LIMITATION OF ABSTRACT UL

THIS PAGE INTENTIONALLY LEFT BLANK

Approved for public release; distribution is unlimited

DESIGN AND OPTIMIZATION OF A HYPERSONIC TEST FACILITY FOR
SUBSCALE TESTING

Stephen R. O'Kresik
Lieutenant, United States Navy
B.S.M.E., University of Arizona, 1996

Submitted in partial fulfillment of the
requirements for the degree of

MASTER OF SCIENCE IN ASTRONAUTICAL ENGINEERING

from the

NAVAL POSTGRADUATE SCHOOL
December 2003

Author: Stephen R. O'Kresik

Approved by: Jose O. Sinibaldi
Thesis Advisor

Garth V. Hobson
Second Reader

Anthony J. Healey
Chairman, Department of Mechanical and
Astronautical Engineering

THIS PAGE INTENTIONALLY LEFT BLANK

ABSTRACT

The Rocket Propulsion and Combustion Laboratory at the Naval Postgraduate School was evaluated to determine if the currently installed systems could support the operation of a subscale hypersonic test stand. Trait analysis of existing lab support sub-systems was performed and an envelope of operation, defined by flight altitude and flight Mach number was determined. Calculations revealed that if the air supply volume was doubled to 160 ft³, a hypersonic blow-down facility could generate conditions to perform testing in the dynamic pressure window of 500 to 2000 psf, from Mach 5 to 7.5 with a maximum system mass flow rate variation from 3 to 45 lbm/s. Additionally, a dynamic design process was outlined to assist other designers in producing similar test stands. Finally, a software analysis package was developed to analyze proposed changes in the support system architecture.

THIS PAGE INTENTIONALLY LEFT BLANK

TABLE OF CONTENTS

I.	INTRODUCTION.....	1
A.	MOTIVATION.....	1
B.	BACKGROUND.....	2
1.	Air Heating Methods.....	3
a.	<i>Pebble Bed Heating</i>	3
b.	<i>Vitiated Heating</i>	4
c.	<i>Arc and Shock Heating</i>	5
2.	The Evaluation Process.....	5
a.	<i>Combustor Pressure Limits</i>	6
b.	<i>Combustor Temperature Limits</i>	6
c.	<i>Combustor Mach Number Limits</i>	7
C.	OBJECTIVES.....	7
II.	DESIGN AND ANALYSIS.....	9
A.	PHYSICAL LIMITATIONS.....	9
B.	EVALUATION OF RPCL'S SCRAMJET FACILITY.....	11
1.	Existing Subsystems.....	12
a.	<i>Air Subsystem</i>	13
b.	<i>Vitiated Heating Subsystem</i>	15
2.	Testing Time.....	17
3.	Facility Nozzle Throat Area.....	18
C.	TEST STAND DESCRIPTION.....	20
D.	SCALING.....	23
III.	SOFTWARE DESIGN.....	27
A.	SOFTWARE DESIGN OVERVIEW.....	27
B.	SOFTWARE LIMITATIONS.....	28
1.	Modeling Limits.....	28
2.	Programming Limitations.....	30
C.	MODELS.....	30
1.	Atmospheric Model.....	30
2.	Combustor Stagnation Pressure.....	35
3.	Stagnation Temperature.....	38
4.	Choked Flow Calculator.....	44
5.	Vitiator Flow Rates.....	46
6.	Testing Time.....	48
7.	Facility Nozzle Throat Area and Area Ratio.....	51
IV.	RESULTS.....	53
A.	AIR PRESSURE SOURCE.....	53
B.	VITIATOR DESIGN.....	55
C.	FACILITY NOZZLE.....	56
V.	CONCLUSION.....	59

APPENDIX A. PROGRAM LISTING..... 61
LIST OF REFERENCES..... 69
INITIAL DISTRIBUTION LIST..... 71

LIST OF FIGURES

Figure 1. Mass Flow Rate as a Function of Temperature for 2560 psi.....	15
Figure 2. Variation of Oxygen Content in Vitiated Air [$P_t=1000$ psi].....	16
Figure 3. Facility Nozzle Throat Area for 2560 psi.....	20
Figure 4. Process Overview (not all processes were modeled). ..	22
Figure 5. Schematic Representation of the Thermodynamic Processes of the Test Stand (not to scale).....	23
Figure 6. Program Flow Path.....	27
Figure 7. Dynamic Pressure Limited Flight Profile.....	32
Figure 8. 'atmosphericsolver' SIMULINK model.....	33
Figure 9. 'stagnationpressure' SIMULINK model.....	36
Figure 10. Lines of Constant Combustor Stagnation Pressure..	37
Figure 11. Lines of Constant Stagnation Pressure within the Flight Envelope.....	38
Figure 12. 'stagnationtemp' SIMULINK model.....	39
Figure 13. Lines of Constant Stagnation Temperature.....	40
Figure 14. Lines of Constant Stagnation Temperature in the Flight Envelope.....	42
Figure 15. Close up of the Region of Operation.....	43
Figure 16. 'Chokedflowrate' SIMULINK model.....	45
Figure 17. 'Combustionflow' SIMULINK model.....	47
Figure 18. 'systemruntime' SIMULINK model.....	49
Figure 19. 'Makesystemruntime' SIMULINK model.....	50
Figure 20. 'findmyexitmachnumber' SIMULINK model.....	52
Figure 21. Region of Operation in the Flight Window.....	53
Figure 22. Mass Flow Rates versus Stagnation Temperatures at various Stagnation Pressures.....	56
Figure 23. Facility Nozzle Throat Area Variation.....	57

THIS PAGE INTENTIONALLY LEFT BLANK

LIST OF TABLES

Table 1.	Combustor Inlet Boundary Conditions.....	7
Table 2.	Matched Conditions.....	21

THIS PAGE INTENTIONALLY LEFT BLANK

NOMENCLATURE

SYMBOL	DESCRIPTION	UNITS
a	Speed of sound	$\frac{ft}{s}$
A	Area	in^2
A^*	Critical area	in^2
D_I	Damköhler's first number	N/A
F/A	Fuel to Air ratio	N/A
g_c	Gravitational constant	$\frac{ft-lbm}{lbf-s^2}$
L	Characteristic dimension	ft
M	Mach number	N/A
\dot{m}	Mass flow rate	$\frac{lbm}{s}$
$P_{combustor}$	Combustor static pressure	psi
$P_{dynamic}$	Dynamic pressure	psf
$P_{freestream}$	Freestream static pressure	psi
$P_{static, P}$	Static pressure	psi
P_t	Stagnation pressure	psi
R	Gas constant	$\frac{ft-lbf}{lbm-^{\circ}R}$
Re	Reynolds number	N/A
$T_{static, T}$	Static temperature	$^{\circ}R$
V, u	Velocity	$\frac{ft}{s}$
γ	Ratio of specific heats	N/A

η_c	Compression efficiency	N/A
μ	Viscosity	$\frac{\text{lbm}}{\text{ft-s}}$
ρ	Density	$\frac{\text{lbm}}{\text{ft}^3}$
t	Chemical conversion time	s
τ	Maximum T_{static} ratio	N/A

I. INTRODUCTION

A. MOTIVATION

In August of 2002, an Australian led design team tested a low-cost hypersonic engine. The air-breathing scramjet (supersonic combustion ramjet) engine was accelerated to supersonic speeds by means of a solid rocket motor powered missile. The air-breathing engine was then started and positive thrust was achieved. This modest success has motivated designers to reinvestigate applications for scramjet engines. One area of interest to the space industry is combined cycle rocket engines, that promise to reduce launch costs from \$10,000 per lb to \$1000 per lb. To support the verification of new designs, hypersonic test facilities are necessary. A forward thinking method of developing an optimized hypersonic test facility was formulated. Specifically, the Rocket Propulsion and Combustion Laboratory (RPCL) at the Naval Postgraduate School was evaluated to determine if the site and support sub-systems were suitable to support a hypersonic test stand.

Scramjet propulsion provides an air breathing method of achieving speeds above Mach 5, and provides the promise of reducing the cost to access space. Traditional vertical launch methods are costly, estimated at \$10,000 per pound of payload because the fuel and oxidizer must be carried onboard the vehicle, and accelerated, with the payload to escape velocities. Additionally, bipropellant rockets provide limited specific impulse (Isp). A combined cycle launch vehicle may contain a hypersonic engine as an intermediate stage on a conventional chemical rocket. Such

a combined cycle configuration would use the chemical fuel and oxidizer stored on board the vehicle for initial launch and acceleration to speeds where sustained supersonic combustion can be achieved at, approximately Mach 4 to 5. At this time, the air breathing engine would be used to augment the thrust of the main rocket engines. This concept provides a higher Isp and a lower cost to access space due to the fact that the combined cycle rocket carries less fuel and considerably less oxidizer and thus its mass is significantly less than a conventional launch vehicle. This drastic reduction of the launch vehicle's mass yields an order of magnitude increase in payload mass, which reduces the cost to launch payloads into space down to roughly \$1,000 per pound (Ref. 1).

Hence, the desire to test small scale hypersonic engines for sustained periods of time provides the motivation for universities to establish low-cost test facilities to study the processes involved in optimizing the performance of these engines. This thesis provides a road map to the process of designing and optimizing a blow-down facility for the testing of subscale combustors. Air heating methods are introduced but, vitiated heating is analyzed for this design, due to its simplicity and low cost.

B. BACKGROUND

There is a wide variety of methods available to achieve the supersonic flows required to supply scramjets, and as Lu and Marren (Ref. 2) state, that the goal of any ground based test facility is "Duplication" in which all aspects of the flight environment are matched. Lu and Marren note that this is rarely achievable and further

state that useful test results can be derived from a facility that "Replicates" the flight environment. In this realm, flight temperature, pressure, velocity and chemical composition conditions are met. Finally, "Simulation" is presented as the last area of operation where some important parameters of the flight environment are equated.

1. Air Heating Methods

The cost of the test facility is directly dependent on the accuracy to which the flight environment is *duplicated*. For example, chemically accurate air compositions are most readily obtained by heating the air with a pebble-bed heater, but these units are costly and the university test facility designer is forced to utilize other means. It is important to note that achieving the high enthalpy required to match the flight environment is perhaps the most challenging aspect of designing a hypersonic test stand. The design of the heater affects the maximum enthalpy of the airflow, as well as the chemical composition of the air and the maximum mass flow rate sustainable by the system.

Since so many test parameters rely on the design of this component, it is wise to investigate some of the available options further.

a. Pebble Bed Heating

As stated earlier, one option is the pebble-bed heater, which consists of a several layers of ceramic spheres that are heated using a combustion cycle or electrical heating units. When a target temperature is reached, the combustor is turned off and high pressure air flow is directed through the matrix of pebbles, where it is

heated. In this manner, no chemical impurities are introduced to the air and the chemical composition is accurate to what would be seen during in-flight conditions. However, as stated before, these units are prohibitively costly for most universities.

b. Vitiated Heating

Combustion heating of the supply air is another option that is available to produce the high enthalpies needed to support testing. In this method, a high pressure burner section located before the facility nozzle is used to start, support and maintain combustion during the duration of the test run. The chemical composition of the air supplied to the facility nozzle will depend on the type of fuel used to heat the air. When hydrogen is used as the fuel, with oxygen and N_2 as the oxidizer, water and very minute amounts of NO_x , OH, O_2 , N_2 , H_2 , O, and H will be the by-products of the combustion. The concentration of each of these species depends on the conditions in which the combustion occurs. The result is essentially air with by-products and surplus water which absorbs a significant amount of heat. Vitiated heating as this method is called also requires running the fuel and oxidizer flow-rates at stoichiometric correct ratios to ensure that the O_2 content in the final mixture is correct. Depending on the size of the facility and therefore the flow-rates involved, this method provides acceptable facility run times, and the most economical solution to the university facility designer.

c. Arc and Shock Heating

Two other air-heating methods are not suitable for this analysis because they support only very short test durations which is unsuitable for testing the operation of the combustor sections of hypersonic vehicles.

Arc heating of the airflow is one of these methods and while it is capable of achieving very high enthalpies, Lu and Marren state that chemical impurities will most likely be present in the air and only small flow rates are sustainable. Finally, shock facilities are capable of producing "clean" air but the test time length is not sufficient for testing combustor sections alone.

In this thesis, the use of vitiated heating was chosen as the method used for generating the high enthalpies needed to support this test facility. Vitiating heating requires a lower initial investment than pebble-bed heating and if designed and operated correctly, it can produce high quality air over a range of enthalpies and at a flow rates that are useful for testing scramjets.

2. The Evaluation Process

The first step in designing the test facility is determining the parameters that need to be matched and the ranges of interest for those variables. In the case of hypersonic propulsion, the parameters of interest are outlined in reference 2. For a blow-down facility, the component of interest is the supersonic combustor of a scramjet engine, and the combustor inlet conditions are the parameters that need to be matched. However, depending on the specific scramjet design and vehicle flight profile, the combustor inlet conditions vary greatly between

designs. In an effort to ensure maximum utility of the final design, the collection of performance data, by Heiser and Pratt (Ref. 3) was consulted. Specifically, the data for combustor static pressure, static temperature and Mach number were used.

a. Combustor Pressure Limits

Heiser and Pratt identify the following limits. Combustor static pressures are typically in the range of 0.5 to 10 atmospheres. The upper limit is "... a value that will lead to "reasonable" or "acceptable" weight, complexity and cost." While the lower limit is to minimize the "... length of the combustor required to complete the reaction and consume the available fuel...".

b. Combustor Temperature Limits

The combustor temperature limits are based on maximizing the thermodynamic cycle efficiency. For flight at the same altitude and Mach number, a lower combustor inlet temperature means additional heat must be added in the combustor to support the same thrust. This means greater fuel consumption by the engine and lower efficiency. Therefore higher combustor inlet temperatures are desirable, but as Heiser and Pratt note, if the combustor inlet static temperature is too high, dissociation will occur, which results in a loss of energy due to the dissociation process and subsequently lower efficiencies. Because of this limitation, Heiser and Pratt state that the maximum combustor entrance static temperature is "... almost always found to be in the relatively narrow range of 2600-3000 °R..." To bound the

value for temperature requirement, their "...representative estimate of 2800 °R..." was used.

c. Combustor Mach Number Limits

Finally, appropriate values for the combustor inlet Mach number were needed and determined again from reference (3). A close look at the relationship between Mach number and static temperatures shows that for air at temperatures ranging from ambient to 3000°R the average value for γ , the ratio of specific heats, is 1.36. The maximum ratio of combustor to free stream static temperatures is normally found to be about 7. Using these values, the minimum flight Mach number that ensures supersonic combustor inlet flow was calculated to be approximately Mach 7.

C. OBJECTIVES

This collection of data, summarized in Table (1), forms the boundaries within which a test facility should operate in order to supply flow useful for testing hypersonic combustors.

Table 1. Combustor Inlet Boundary Conditions

	Lower limit	Upper limit	Units
Pressure	0.5	10	Atm
Temperature	None	2800	°R
Mach number	7	>7	N/A

Based on this information, the volume of the air tanks and the size of the supply lines and limitations of installed regulators at the RPCL were analyzed to determine if they could support the operation of a test facility with these outlet conditions for a period of time that would allow the collection of meaningful data to evaluate sub-scale tests of hypersonic combustor designs. Additionally, this information formed the basis for a program that was developed to allow for analyzing the effects of changing many different parameters.

II. DESIGN AND ANALYSIS

A. PHYSICAL LIMITATIONS

The first calculation in the process was to define the flight envelope; this condition limits the stress on the vehicle frame at higher dynamic pressures and ensures sufficient oxygen concentration at lower dynamic pressures. The values were calculated using equations (1) through (4) and the United States Standard Atmosphere Tables 1976 (Ref. 4).

$$M = \frac{V}{a} \quad (1)$$

$$a = \sqrt{g g_c RT} \quad (2)$$

$$P = rRT \quad (3)$$

$$P_{dynamic} = \frac{rV^2}{2g_c} \quad (4)$$

$$P_{dynamic} = \frac{g}{2} P_{static} M^2 \quad (5)$$

where: P_{static} is a function of altitude

The formula for dynamic pressure is equation (4) but the density is altitude dependent and the velocity is temperature dependent. To account for these variations, equation (3) was solved for density and equation (1) and (2) were solved for velocity. Resulting in equation (5), the dynamic pressure was then calculated as a function of the independent variables which were the Mach number defined in equation (1) and P_{static} . The next aspect of the solution was to determine the combustor stagnation pressure

and temperature conditions that fall inside this flight profile. To do this the stagnation conditions were calculated using the free-stream conditions using equations (6) and (7). Then those results were translated using equation (8) and the fact that the adiabatic compression process does not change stagnation temperature conditions.

$$P_t = P_{static} \left(1 + \frac{(g-1)}{2} M^2 \right)^{\frac{g}{g-1}} \quad (6)$$

$$T_t = T_{static} \left(1 + \frac{(g-1)}{2} M^2 \right) \quad (7)$$

The free stream stagnation temperature was calculated from the static temperature which was a function of altitude, obtained from the atmospheric model, and the free stream Mach number which was known. Since the compression process using oblique shocks was analyzed as an adiabatic process, the free stream stagnation temperature and the combustor inlet stagnation temperature had to be equal. Also one of the premises of the problem was that the maximum combustor inlet static temperature was limited to 2800 °R, (Ref. 3) as stated previously, this conservative value was then substituted into the stagnation temperature relationship and used to find the combustor inlet Mach number.

The fact that the oblique shock compression process is adiabatic means that the free stream and combustor inlet stagnation pressures are not equal. Therefore, equation (8) is used to relate the static conditions in the free

stream and the combustor inlet through the use of the compression efficiency, η_c and the maximum static temperature ratio, τ . To perform this calculation, the free stream static pressure was determined next. It is a function of altitude and obtained via the atmospheric model. The free stream Mach number was the independent variable and therefore a known value. Next, the combustor static pressure was evaluated using equation (8).

$$P_{combustor} = P_{freestream} \left(\frac{\gamma}{\gamma(1-n_c) + n_c} \right)^{\frac{g}{g-1}} \quad (8)$$

Then combustor inlet stagnation pressure was calculated using the combustor inlet Mach number and equation (6) the stagnation pressure isentropic relationship.

B. EVALUATION OF RPCL'S SCRAMJET FACILITY

With the physical limitations of the processes defined, the next step was to evaluate the proposed site. This process of designing the components to supply the high temperature, high pressure and subsequently the high Mach number air to a test combustor can be accomplished in two different ways.

In the first method, the air supply requirements of a prototypical scramjet are supplied to a test facility. Normally this is in the form of stagnation pressure, stagnation temperature, Mach number and mass flow-rate requirements. Using this information an engineer can

design the heating section and convergent-divergent nozzle to develop these flow conditions. The result would be a test stand that is specifically designed to support such a prototype combustor. It is however unlikely that this test stand would fully utilize the capabilities of the facility support systems (i.e. specifically, the air supply system). Additionally, it would probably require significant redesign to accommodate future prototype combustors that were submitted to the test facility for evaluation, even if only one of the test parameters that formulated the initial design were changed.

A more dynamic approach allows the designer to define the operational envelope of a proposed test stand based on current laboratory support system capabilities. In this way, a proposed solution can be designed to utilize the full capacity of any existing facility support systems. If the design process is translated into software, then the designer gains the ability to quickly investigate the effects of changing certain parameters on the performance of the proposed test stand. Allowing this evaluation of performance without having to purchase additional hardware is a very attractive feature to designers working with small budgets. In the end, a suitable and versatile solution to testing sub-scale hypersonic combustors can be achieved. Using this second method, the RPCL, at the Naval Postgraduate School was evaluated to determine its ability to support the operation of a hypersonic test stand.

1. Existing Subsystems

Several of the required support sub-systems were already in place and operational. These included, the air

supply system, and hydrogen and oxygen supply systems. The air sub-system is supplied by two air compressors. Both are manufactured by Bauer, the compressor with the highest capacity is rated at 50 cfm and the other delivers approximately 30 cfm. This high pressure air is directed to four 20 ft³ high pressure storage tanks which can store air at a maximum pressure of 3000 psi. Air from these storage tanks is piped to several test bays using 1½" stainless steel tubing. A pressure regulating valve upstream of the test bay connections regulates actual air supply pressure up to 1000 psi. Compressed hydrogen and oxygen cylinders are also installed at the facility and directed to several test bays using ½" stainless steel tubing.

a. Air Subsystem

The choked air flow rate for the current air supply piping size was calculated to generate an upper limit for the maximum mass flow rate that can be supplied to a test article.

It is important to note that the air tank static temperature changes over the course of a test run. This is due to the fact that the air is being supplied through an isentropic expansion process from the air supply tanks. This aspect of the process was included to account for the large variation in supply temperature that occurs during tank blow-down.

Starting with the isentropic expansion equation to determine mass flow rate/area:

$$\frac{\dot{m}}{A^*} = M \left(1 + \left(\frac{g-1}{2} \right) M^2 \right)^{\frac{-(g+1)}{2(g-1)}} \sqrt{\frac{g g_c}{R}} \frac{P_t}{\sqrt{T_t}} \quad (9)$$

The variables above were specified and supplied to the equation and a choked area for the desired mass flow rate was found. The process was repeated for all of the gas supply systems using the appropriate system parameters.

Equation (9) was evaluated for the values of combustor stagnation pressure that fell within the flight profile. Stagnation pressures ranged from 337.5 to 2563 psi and the stagnation temperature was set to 70 °F. This ensured that a test stand designed to accommodate this maximum mass flow rate would not encounter choked flow in the air supply system. The air piping diameter is 1 ½" downstream of the regulator. A high stagnation pressure estimate of 2563 psi with a stagnation temperature of 70°F (530°R) was used to calculate the maximum air system mass flow rate. As stated before, the temperature estimate is conservative because no cooling was assumed in the choked flow calculation. Using these parameters, it was determined that the maximum airflow rate was about 50 lbm/sec.

The choked system flow rates were then calculated for each of the combustor stagnation pressure and temperature values that were found to fall within the flight window. The results for the total air system flow rates varied as shown in figure (1).

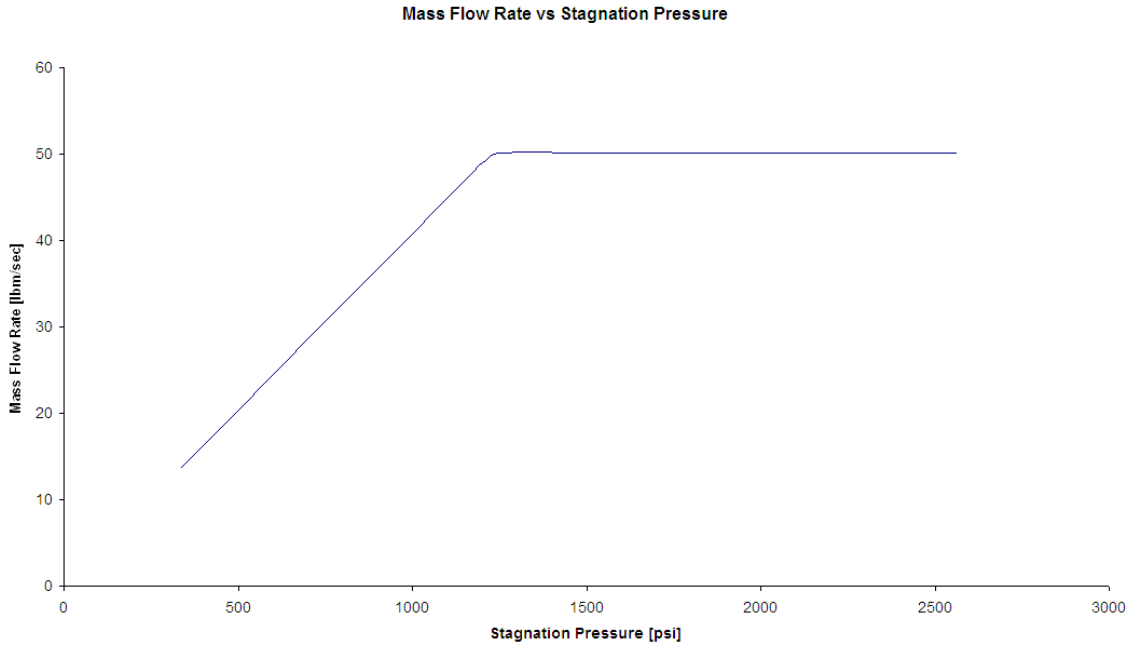

Figure 1. Mass Flow Rate as a Function of Temperature for 2560 psi

b. Vitiated Heating Subsystem

The next calculation that was performed was based on determining the required mass flow rate to generate the combustor inlet stagnation temperature at the combustor inlet stagnation pressure. This was done using a look-up table based on combustion data calculated with Thermo-Chemical Equilibrium Program (TEP). The combustion data was generated using hydrogen as the fuel and varying amounts of air and oxygen as the oxidizer, and was performed at 17, 34, 51, 68, 85, 102, 120 atm. The air mass concentration was held constant and the fuel/air ratio was varied to produce a mixture with 21% oxygen after combustion. The final oxygen content was adjusted so that all variations were contained within $\pm 0.33\%$.

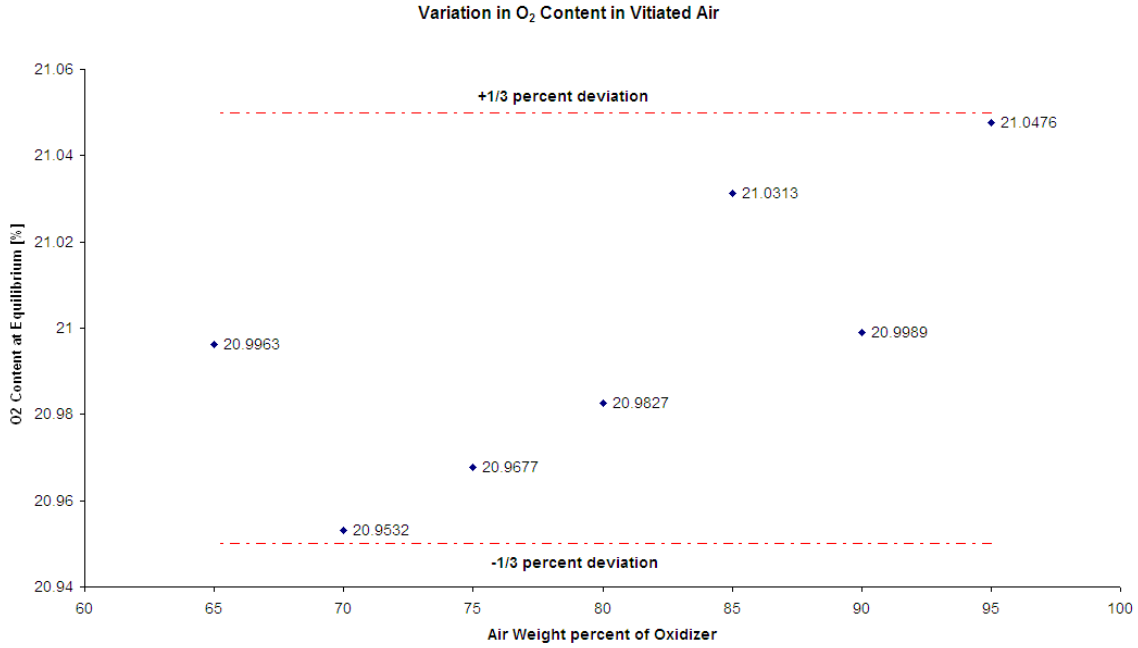

Figure 2. Variation of Oxygen Content in Vitiated Air
[P_t=1000 psi]

The air mass concentration and fuel/air ratio were recorded. The mixture's molecular weight, density, and ratio of specific heats were also tabulated and entered into the look-up table. Then using the relationship between mass flow rate of air and the air mass concentration, the mass flow rate of the oxidizer and oxygen were found. Similarly, using the mass flow rate of oxidizer and fuel/air ratio, the mass flow rate of hydrogen was found. These relationships are described in equations (10) through (14).

$$\dot{m}_{total} = \dot{m}_{oxidizer} + \dot{m}_{fuel} \quad (10)$$

$$\dot{m}_{oxidizer} = \dot{m}_{air} + \dot{m}_{oxygen} \quad (11)$$

$$\dot{m}_{air} = \text{Weight}\%_{air} (\dot{m}_{oxidizer}) \quad (12)$$

$$\dot{m}_{oxidizer} = \frac{\dot{m}_{air}}{\text{Weight}\%_{air}} \quad (13)$$

$$\dot{m}_{fuel} = \dot{m}_{hydrogen} = F / A (\dot{m}_{oxygen}) \quad (14)$$

These values were calculated so that the hydrogen and oxygen flow rate limits were not exceeded.

2. Testing Time

With the air system flow rate maximized, it was necessary to determine the run time that the air flow rate could be supplied for. Therefore using an air system mass flow rate, 3000 psi initial supply air pressure and a starting supply temperature of 70 °F as the initial conditions in the air supply tank, the corresponding system run time was calculated. This was done using the perfect gas relationship, and the definition of mass flow rate. The mass flow rate equation was simplified for steady flow conditions, which is an assumption of the calculation. Additionally, the continuity equation and the isentropic expansion process were used.

$$\dot{m} = \frac{dm}{dt} \quad (15)$$

$$\dot{m} = \frac{\Delta m}{\Delta t} \quad (16)$$

$$\dot{m} = \frac{m_{initial} - m_{final}}{t} \quad (17)$$

$$\dot{m} = rAV \quad (18)$$

$$\frac{T_{final}}{T_{initial}} = \left(\frac{P_{initial}}{P_{final}} \right)^{\frac{1-g}{g}} \quad (19)$$

$$t = \frac{\mathbf{r}_{initial}V - \mathbf{r}_{final}V}{\dot{m}} \quad (20)$$

Finally the equations were solved for system run time. This result was then evaluated to determine if it was sufficient for conducting meaningful testing based on the criteria outlined by Pope and Goin (Ref. 5). Specifically, they assert that many factors should be considered when determining acceptable system run times. They conclude that the facility designer needs to address pressure stabilization inside the test stand, instrument response times for the test equipment and the type of test to be run. While the instrument response characteristics have undoubtedly improved since 1965, the rate at which pressure stabilizes and system test profiles are still salient points of consideration. Thus this thesis used their initial estimate for acceptable system runtime of 30 s.

If the system run time result is less than 30 s, then the run time was set to 30 s and the air system mass flow rate is calculated, and used for further calculations.

3. Facility Nozzle Throat Area

The sum of the oxygen, air and hydrogen mass flow rates were then used to calculate the facility nozzle choked area, using the choked flow equation (9) presented earlier. Since the process in the facility nozzle is

isentropic, the vitiator stagnation pressure and stagnation temperature values were used in this calculation as well, refer to equations (6) and (7) (From Ref. 6).

The facility nozzle supersonic area ratio was calculated as follows:

$$\frac{A}{A^*} = \frac{1}{M} \left(\frac{1 + \frac{(g-1)}{2} M^2}{\frac{(g+1)}{2}} \right)^{\frac{(g+1)}{2(g-1)}} \quad (21)$$

Equation (21) was evaluated to determine the area ratio required to generate the highest combustor Mach number. Specifically, the solution was found using Newton's Method (From Ref. 7). Using a starting guess, of Mach 5, equation (21) and (22) were evaluated.

$$\frac{d\left(\frac{A}{A^*}\right)}{dM} = \frac{d\left(\frac{1}{M} \left(\frac{1 + \frac{(g-1)}{2} M^2}{\frac{(g+1)}{2}} \right)^{\frac{(g+1)}{2(g-1)}}\right)}{dM} \quad (22)$$

Then the Mach number, equation (21) (the function), and equation (22) (the derivative), were substituted into equation (23).

$$M_{i+1} = M_i - \frac{f(M)}{\frac{df(M)}{d(M)}} \quad (23)$$

When the $M_{i+1}=0$, the solution was the M_i used in evaluating equation (21) and (22), otherwise $M_i=M_{i+1}$, the new Mach number estimate and the process repeated until a solution was found. Convergence occurred in 2 iterations for almost every case due to the well chosen starting point and the properties of the function itself.

The values for facility nozzle throat area at the various stagnation temperatures and the 2560 psi stagnation pressure (the most limiting condition) were plotted as shown in figure (3). The facility nozzle design was then based on these values.

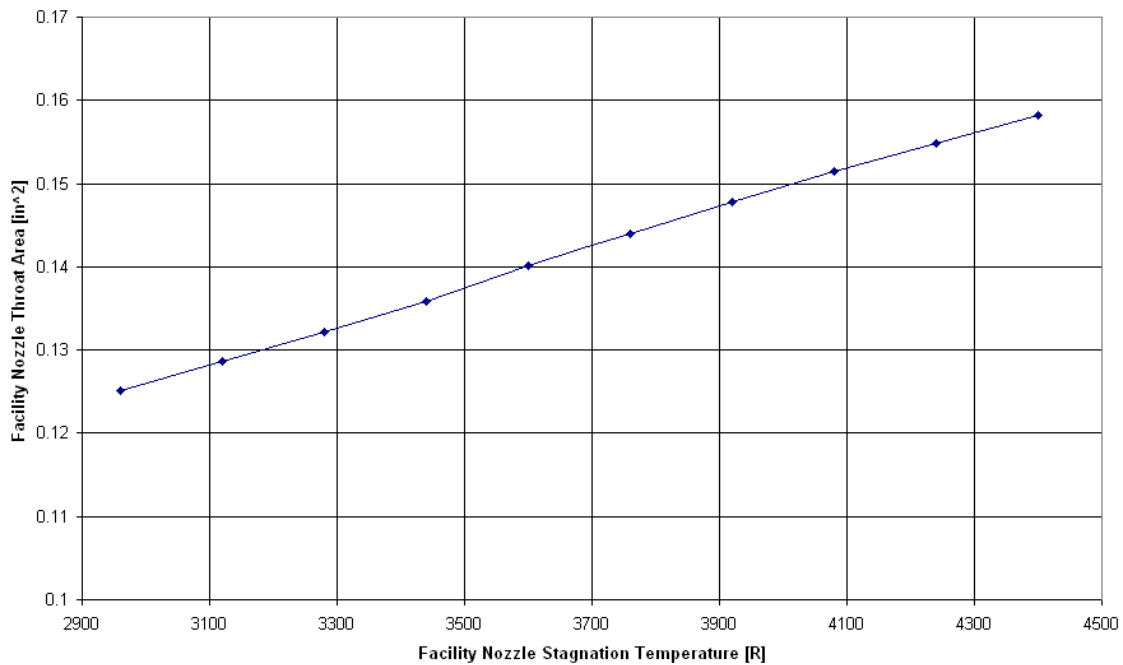

Figure 3. Facility Nozzle Throat Area for 2560 psi

C. TEST STAND DESCRIPTION

Figure (4) is a schematic of the major components required in the construction of a blow-down test facility.

The supply tanks, vitiator, and facility nozzle were analyzed in the previous section. Although various heat transfer processes are listed in figure (4), not all of these were modeled. Further refinement of the presented analysis should consider the modeling of these additional processes.

Nonetheless, all variable targeted conditions depicted at the bottom of figure (4) were computed in the presented analysis. The typical values are listed in table (2).

Table 2. Matched Conditions

Property	Value/Range	Units
Stagnation Pressure	337.5-2560	psi
Stagnation Temperature	2960-4400	°R
Mass Flow Rate	3-45	lbm/s
Run time	1-30	s

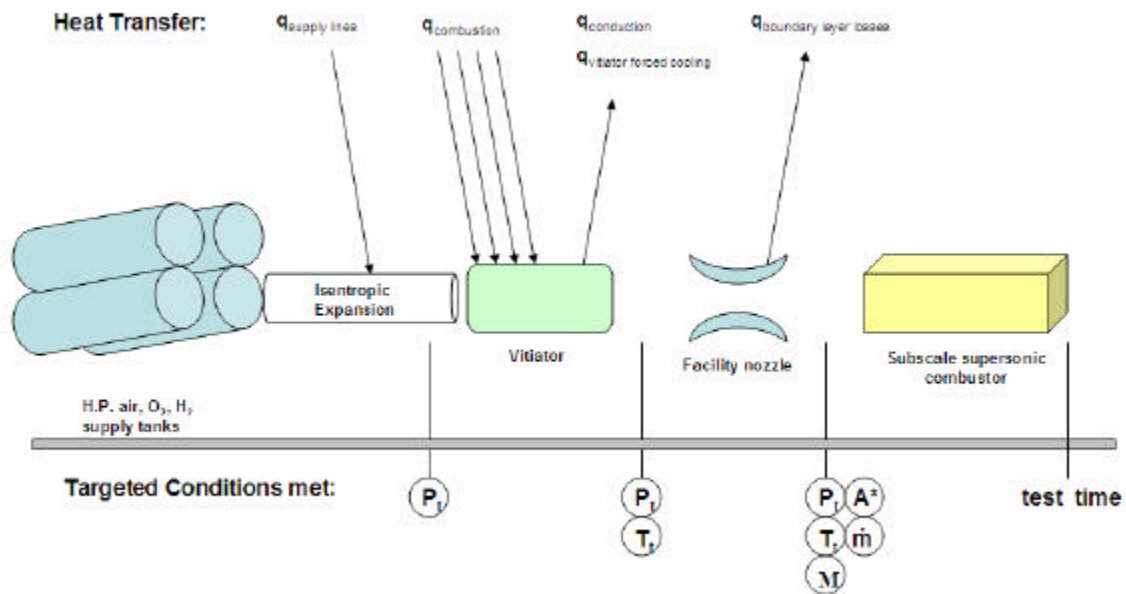

Figure 4. Process Overview (not all processes were modeled)

The thermodynamic processes that occur are further defined in the enthalpy versus entropy plot shown in figure (5). Although the open cycle is not drawn to scale it does show the important processes and the legend shows the correlation between flight and test stand states.

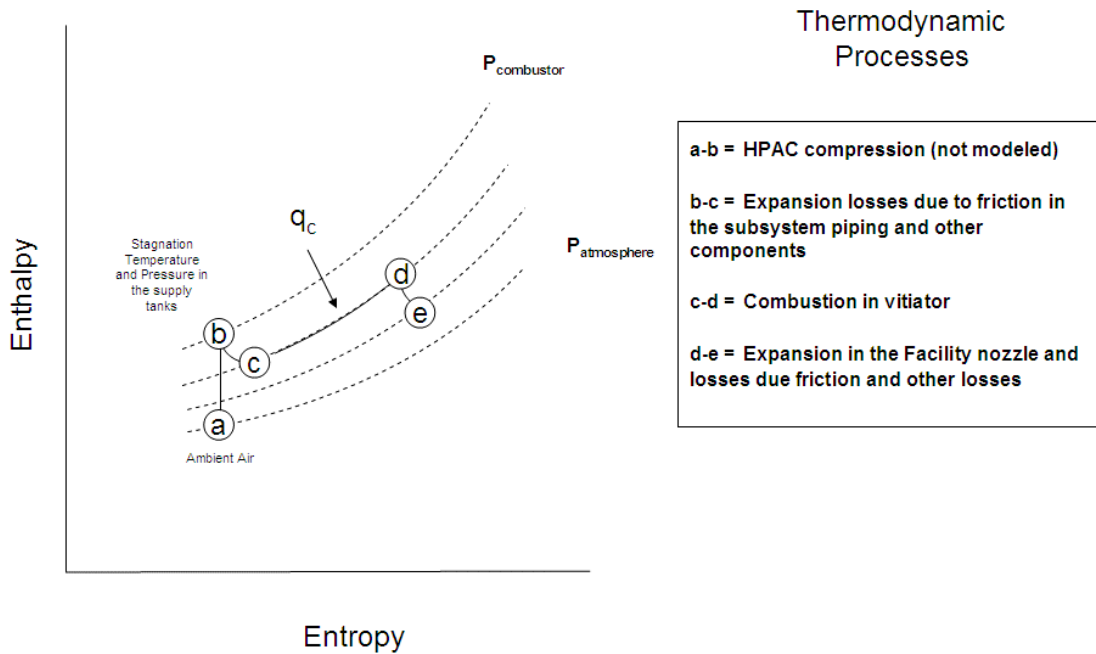

Figure 5. Schematic Representation of the Thermodynamic Processes of the Test Stand (not to scale)

D. SCALING

Another aspect of the design is scaling. The test article will be some fraction of the size of the flight combustor and therefore the flow must be appropriately adjusted to account for the smaller physical size. The test article needs to be both geometrically and dynamically similar to the flight article. Once the geometric similarity requirement is met, dimensional analysis is performed to identify parameters that will ensure dynamic similarity. In Ref. (8) Penner identifies the three factors that will ensure dynamic similarity. They are the Reynolds number, Damköhler's first number and the Mach number.

$$\text{Re} = \frac{\mathbf{r}uL}{\mathbf{m}} \quad (24)$$

$$D_l = \left(\frac{L_{\text{combustor}}}{u} \right) \frac{1}{t} \quad (25)$$

$$M = \sqrt{\frac{\mathbf{r}u^2}{\mathbf{g}p}} \quad (26)$$

$$\mathbf{r}L = \text{constant} \quad (27)$$

$$\mathbf{r}_{\text{test}} L_{\text{test}} = \mathbf{r}_{\text{flight}} L_{\text{flight}} \quad (28)$$

where: if $L_{\text{test}} = \frac{1}{2} L_{\text{flight}}$
 then $\rho_{\text{test}} = 2 \rho_{\text{flight}}$

The dynamic similarity is then established by meeting the requirements of equation (27), which can be expanded to the version shown in equation (28). Specifically, in the case where the test article is half the length of the flight combustor, the test flow density must be twice the flight density (From Ref. 9). Applying this relationship to equations (24) through (26), it is easily shown that the Reynolds number of the flow in the test article is matched when binary scaling is applied, also since density increases with pressure at a near linear rate, Mach number similarity is achieved. However the effect of binary scaling on Damköhler's first number is not so readily seen.

Damköhler's first number, shown in equation (25), is a relationship between the combustor length, flow velocity and chemical conversion time. The numerator represents the residence time, and it is simply the time that air is available for interactions in the combustor. The chemical

conversion time however is process dependent, and is a function of the combustion, dissociation, and recombination reactions taking place. It is important to note that the combustion and dissociation chemical conversion times are the important factors in the chemical conversion time, because for specific mixture states they are almost always less than the residence time of the flow in the combustor. Of less importance is the time required for recombination, since it is significantly greater than the residence time given a flight vehicle length. It then follows, that Damköhler's first number describes the physical state of the combustion reaction.

The chemical conversion time is inversely proportional to a combination of the previously stated reaction rates, and the chemical reaction rate is directly proportional to the pressure at which the reaction is taking place. Since, binary scaling is achieved by increasing the static pressure and therefore the density, the chemical reaction

rates also increase and the chemical conversion time decreases. Referring again to equation (25), if the length of the combustor is halved, then the chemical conversion time must be halved as well. This means that the reaction rates must be doubled and therefore the pressure must also be doubled, which was the case to increase the density to meet the requirements of matching the Reynolds number and the Mach number.

In summary, a test article geometrically similar to the flight model will be dynamically similar if the flow Reynolds number, Damköhler's first number, and the flight Mach number are matched. This dynamic similarity is achieved by using the binary scaling relationship shown in

equation (27). The binary scaling factor will vary depending on the scale of the test article, and the test stand flow can be adjusted by increasing the static pressure at the facility nozzle outlet, which increases the density.

III. SOFTWARE DESIGN

A. SOFTWARE DESIGN OVERVIEW

The purpose of the software is to allow the facility designer to have a resource that will perform much of the comparisons that are required to determine the interdependence of parameters. The software was developed using MATLAB student edition version 6.0 and SIMULINK version 4. SIMULINK was used to model most of the processes which allows the user to more readily see the flow of the solution. The MATLAB code simply links the SIMULINK models. Figure (6) shows the program flow path.

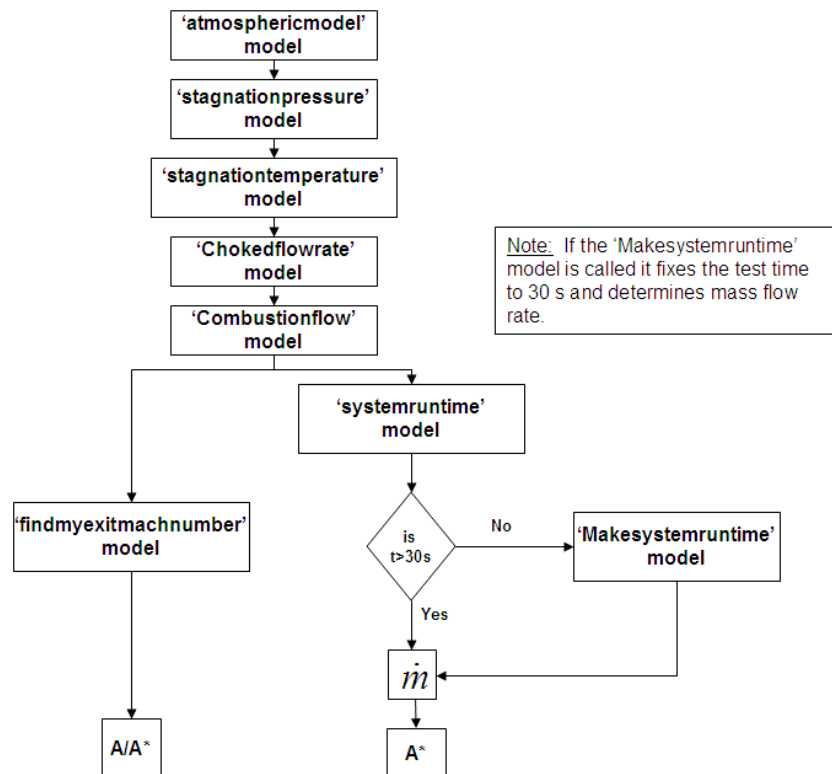

Figure 6. Program Flow Path

The flight conditions in the form of dynamic pressure and combustor stagnation conditions are calculated to establish the boundary conditions that the vitiator and facility nozzle were designed to using the 'atmosphericsolver', 'stagnationpressure', 'stagnationtemp' and 'Combustionflow' models. Then the limitations of the installed support subsystems at RPCL are weighed into the design considerations in the form of sustainable mass flow rates and the test time using the 'systemruntime' and 'makesystemruntime' models. Subsequently, the combustor stagnation conditions, combustor Mach number and mass flow rates are used to determine the facility nozzle choked area and supersonic area ratio of the facility nozzle in the main program and 'findmyexitmachnumber' model.

B. SOFTWARE LIMITATIONS

As with any model, limitations will be present. In this software, there are two categories where inaccuracies will arise. The two areas are physical modeling errors, and programming limitations.

1. Modeling Limits

When modeling a system, the designer has to balance the level of fidelity (necessary to provide meaningful results) and the level of effort or time to achieve them. Despite the effort to ensure a high fidelity model, the use of one-dimensional isentropic flow is not entirely accurate. Although, Computational Fluid Dynamics would provide a more realistic description there are a few reasons why this path was not considered. First, the amount of computational time required would increase by at

least 3 orders of magnitude. This alone would have limited the number of conditions presently considered. Secondly, CFD requires a detailed geometric description of the proposed facility. This level of detail requires a priori knowledge that can only be provided by the models under consideration in this thesis. Therefore, once the final design is reached with the present models, one can use CFD to refine the design. Hence, macroscopic performance results were determined to be the best way to model this system.

Another limitation present in this software was that the mass capacity of the hydrogen and oxygen supply systems was not considered. It is therefore possible that the software would report a feasible solution, when actually the condition is beyond the available total mass of oxygen or hydrogen. Accounting for this aspect of the design was not included in the software because of the objective to keep the software simple in its design. Additionally, for small facilities, the addition of extra O₂ or H₂ cylinders is a trivial matter which is overcome simply by connecting additional cylinders. To estimate the mass of oxygen required, the user only needs to multiply the applicable flow rate and the final test time.

Additionally, the data used to describe the real gas effects on different air and gas mixture properties was organized into look up tables. The tables use linear interpolation for in-between values and linear extrapolation for values outside of the table limits. While the data is almost entirely linear for temperature and pressure values inside the table, dissociation effects are seen near the upper temperature and lower pressure data

point of the table. These values are 4400 °R and 337.5 psi respectively. Thus extrapolation of data values beyond these conditions should be viewed with caution.

2. Programming Limitations

Programming inconsistencies can introduce some errors as well and one method utilized frequently in this software is the use of the 'hit/crossing' function in some of the SIMULINK models (From Ref. 10). This function is used to identify the point where the ramped input, such as the altitude model depicted in figure (8), provides a solution to the problem; however, if the step size of the input variable is not sufficiently small, then the solution may actually not be the correct value.

Regardless of the errors involved due to these limitations, the results of this type of analysis are sufficient to make preliminary design decisions, and highlight areas where a more detailed analysis may be required.

C. MODELS

1. Atmospheric Model

When the program executes, the first figure displayed on the screen is calculated using the 'atmosphericsolver' model. This model generates an Altitude versus Mach number graph based on the limitations outlined in Ref. (2). Look-up tables are used to provide the state conditions of the atmosphere and the data used in the temperature and density look up tables was obtained using the United States Standard Atmosphere 1976 tables (From Ref. 4). The values in the look-up tables were compared with the 1962 United

States Standard Atmosphere tables included in Ref. (11) to ensure accuracy. The look-up tables contain data for a height of 60 km, or nearly 200,000 feet. But as seen in the dynamic pressure formulation, the flight window defined by Ref. (3) peaks out at about 130,000 ft. Therefore, to reduce the program run time, 130,000 ft was chosen as the maximum altitude used for calculations. The model subtracts a reference dynamic pressure (From Ref. 3), from the calculated dynamic pressure and keeps track of that difference. When that difference equals zero (actually crosses zero) the model stops and the altitude is reported, the program then continues execution for the next Mach number. The reference dynamic pressure values (500 and 2000 psf) are sequentially passed to the 'atmosphericsolver' SIMULINK model depicted in figure (8). This model is located inside of a loop that increments the free stream Mach number to the user defined maximum value. For each Mach number value, the model ramps the altitude input from 0 to the maximum altitude (also a user defined value.) Subsequently, the line of constant dynamic pressure is plotted on an Altitude vs Mach number plot as shown in figure (7). The loop continues for each reference value of constant dynamic pressure that was defined. Figure (7) shows the plot of lines of constant dynamic pressure. The upper line represents 500 psf and the lower 2000 psf.

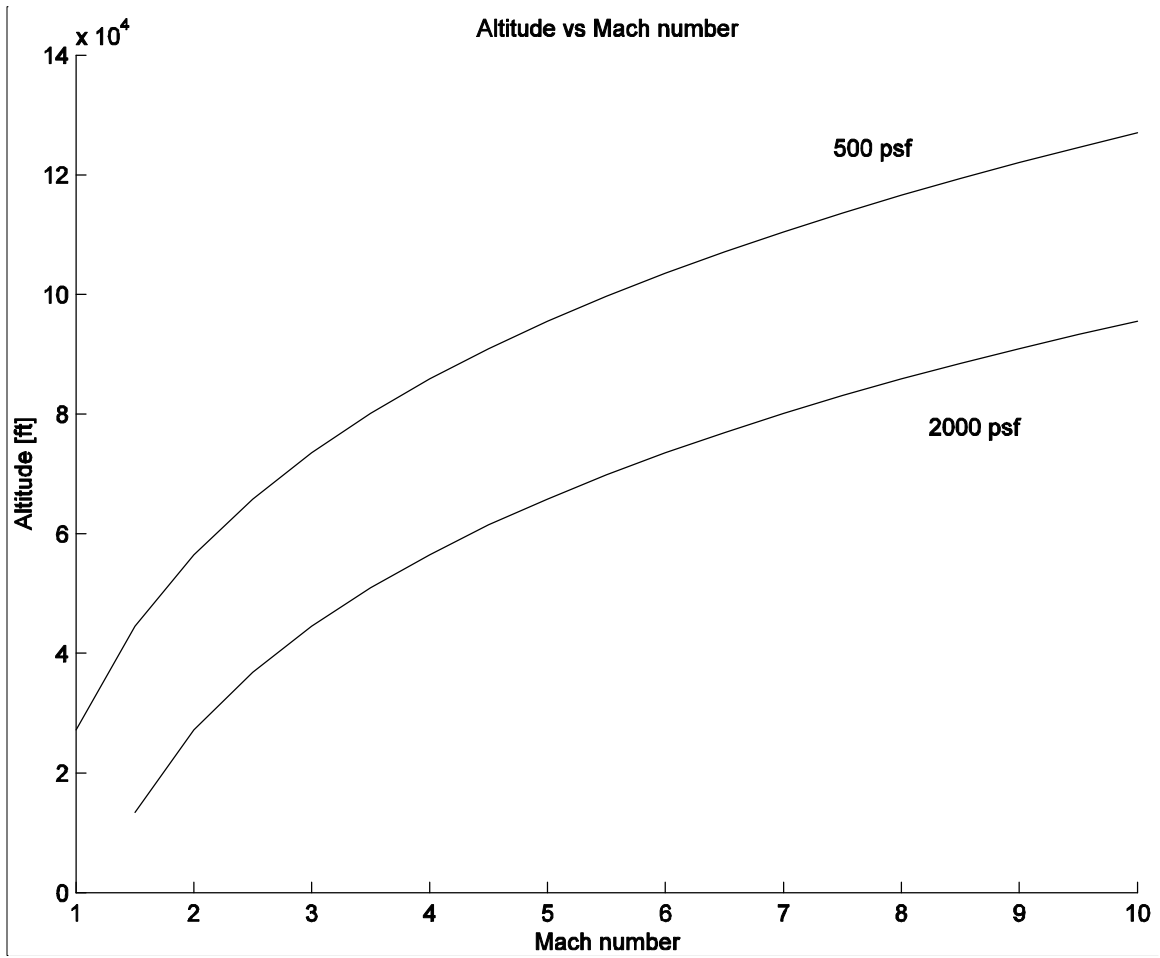

Figure 7. Dynamic Pressure Limited Flight Profile

ALTITUDE versus MACH number CALCULATOR

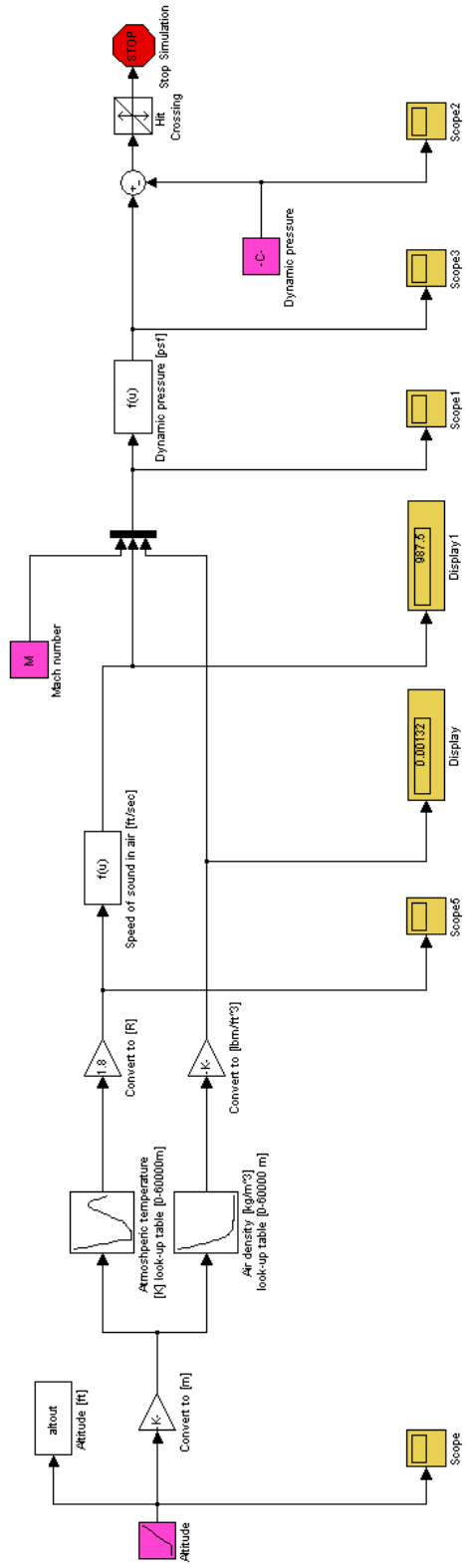

Figure 8. 'atmosphericsolver' SIMULINK model

THIS PAGE INTENTIONALLY LEFT BLANK

2. Combustor Stagnation Pressure

The flight combustor stagnation pressure is determined as depicted in figure (9). Two nested loops allow the reference values of stagnation pressure to be varied between the user defined values, the upper limit being set by the maximum pressure in the supply air tanks at the test facility. The inner loop is the flight Mach number and is varied as described in section (a) for the 'atmosphericsolver' model. The 'stagnationpressure' model shown in figure (9) uses these values to determine the calculated combustor stagnation pressure.

As before, the flight altitude variable is a ramped input and the model uses the same atmospheric model. The static pressure look-up table is used to find the static pressure at the given flight altitude. Using equations (6) and (8), the combustor entrance Mach number and the combustor entry static pressure are determined. The combustor stagnation pressure is then determined and the reference stagnation pressure (convenient values specified by the operation of the outer loop, and chosen within those bounds) is subtracted from it. When the difference equals zero, the model stops and control is shifted back to the m-file. Additionally, the altitude, atmospheric density, atmospheric temperature and combustor Mach number are also passed to the MATLAB m-file. Next, the 'atmosphericsolver' model is used again to determine if the altitude found by the 'stagnationpressure' model falls within the flight profile window. If it does, a point is plotted and the stagnation pressure is recorded.

COMBUSTOR STAGNATION PRESSURE CALCULATOR
 This calculates lines on constant stagnation pressure
 Ratio of specific heats is 1.36

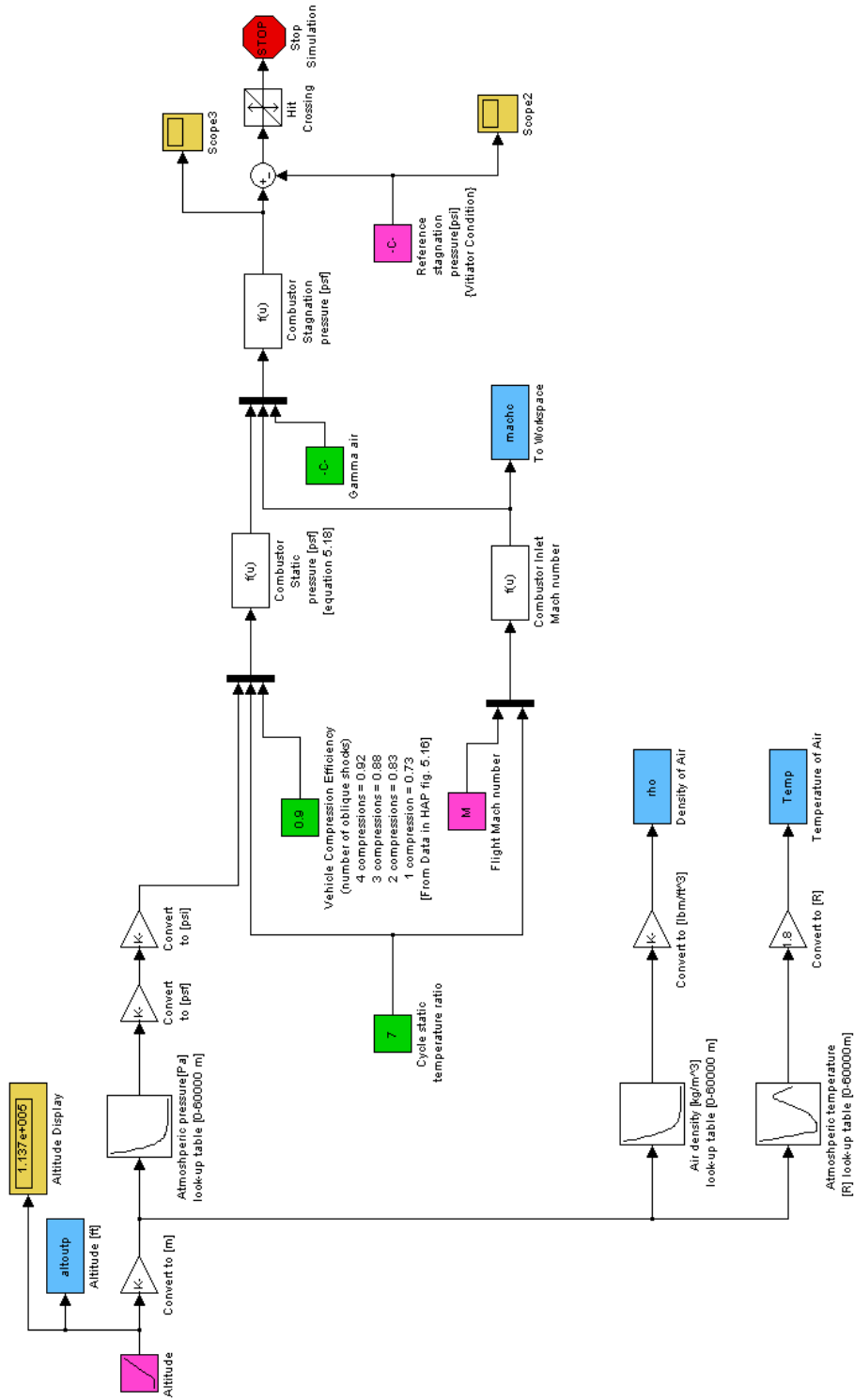

Figure 9. 'stagnationpressure' SIMULINK model

The stagnation pressure is recorded so that it can be evaluated later in the program to see if it meets the minimum run time requirement. Also, the combustor Mach number is recorded if its value is larger than any previous values of combustor Mach number. This is done to define an iteration limit, used later in the program for calculating the supersonic area ratio of the facility nozzle. This process is repeated until all values between the stagnation pressure limits have been evaluated for each Mach number specified by the inner loop. These results are shown in figure (11). For clarity, an unreduced set of data spaced at 250 psi intervals is plotted in figure (10).

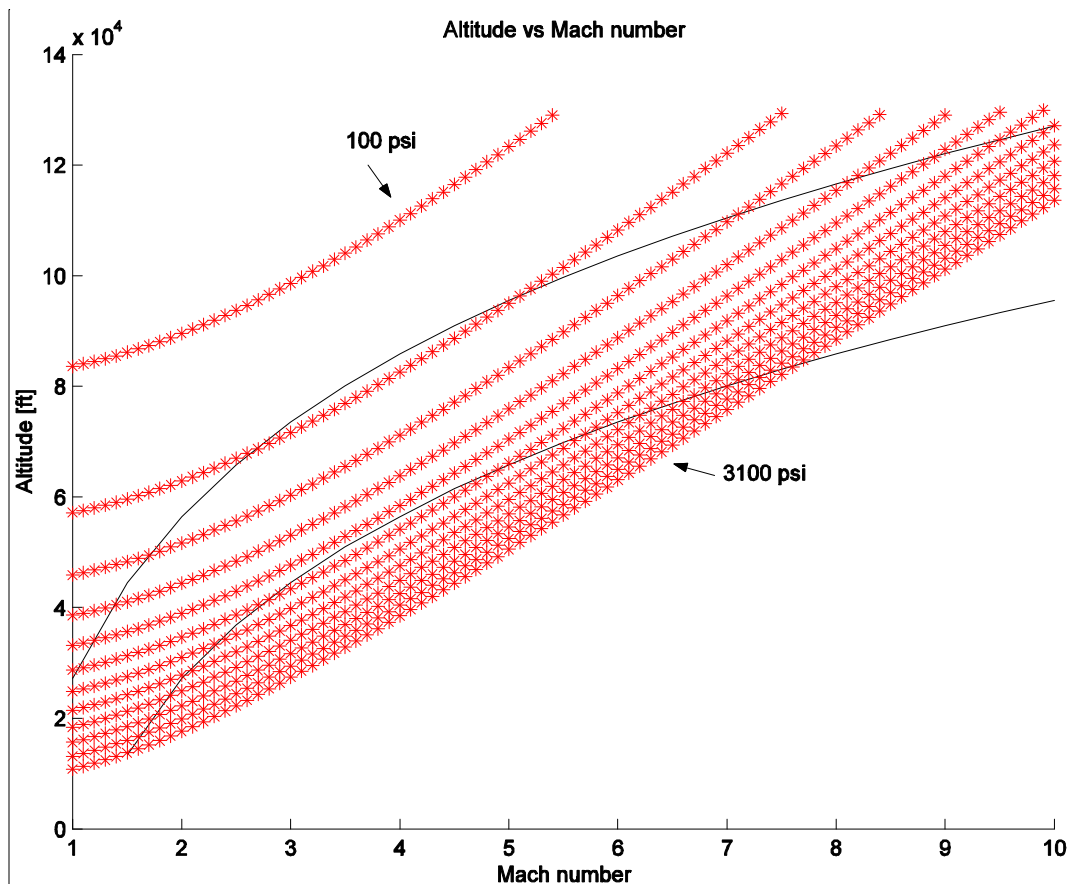

Figure 10. Lines of Constant Combustor Stagnation Pressure

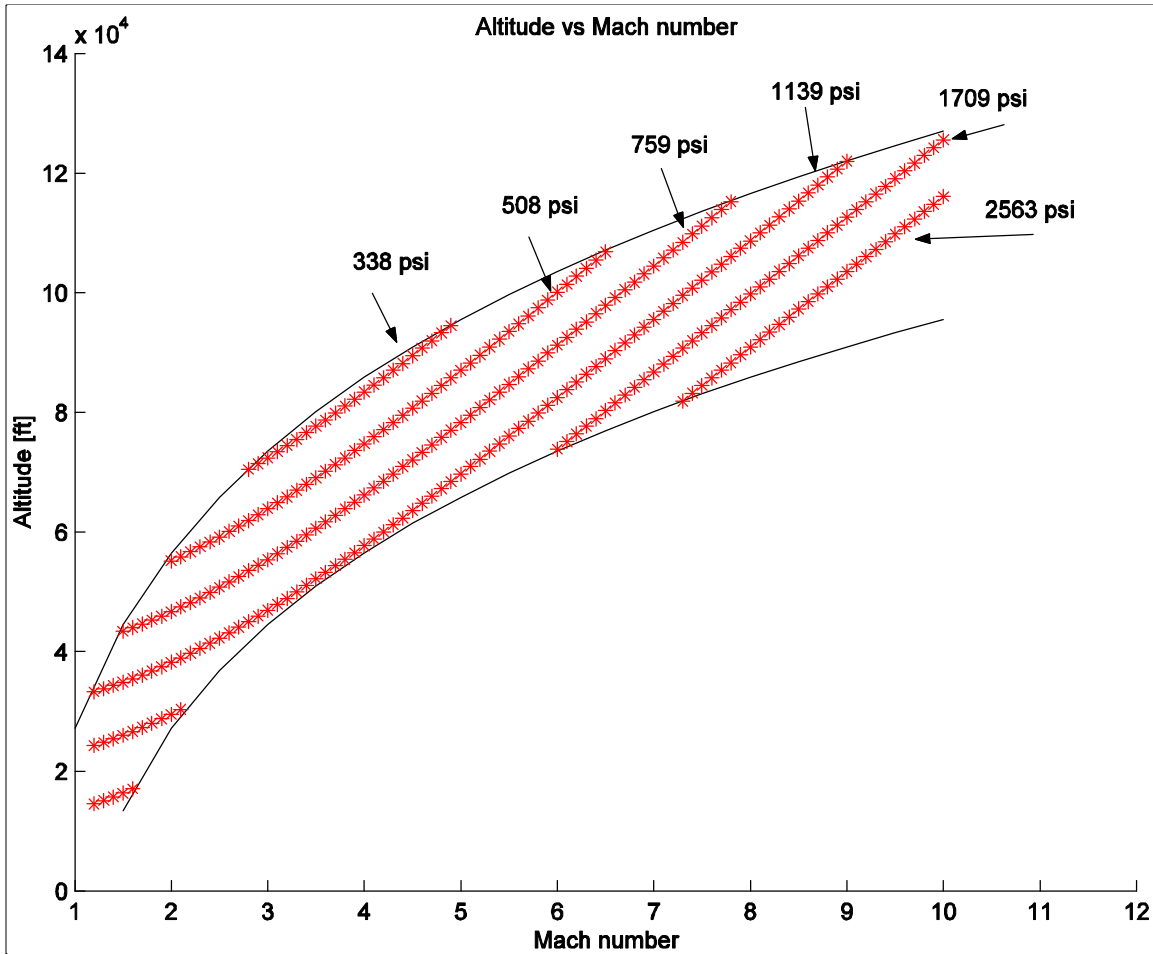

Figure 11. Lines of Constant Stagnation Pressure within the Flight Envelope

3. Stagnation Temperature

The next step is to determine the combustion stagnation temperatures that fall within the flight profile dynamic pressure limits. This is performed by the 'stagnationtemp' model shown in figure (12) and the results are shown below in figure (14).

COMBUSTOR STAGNATION TEMPERATURE CALCULATOR

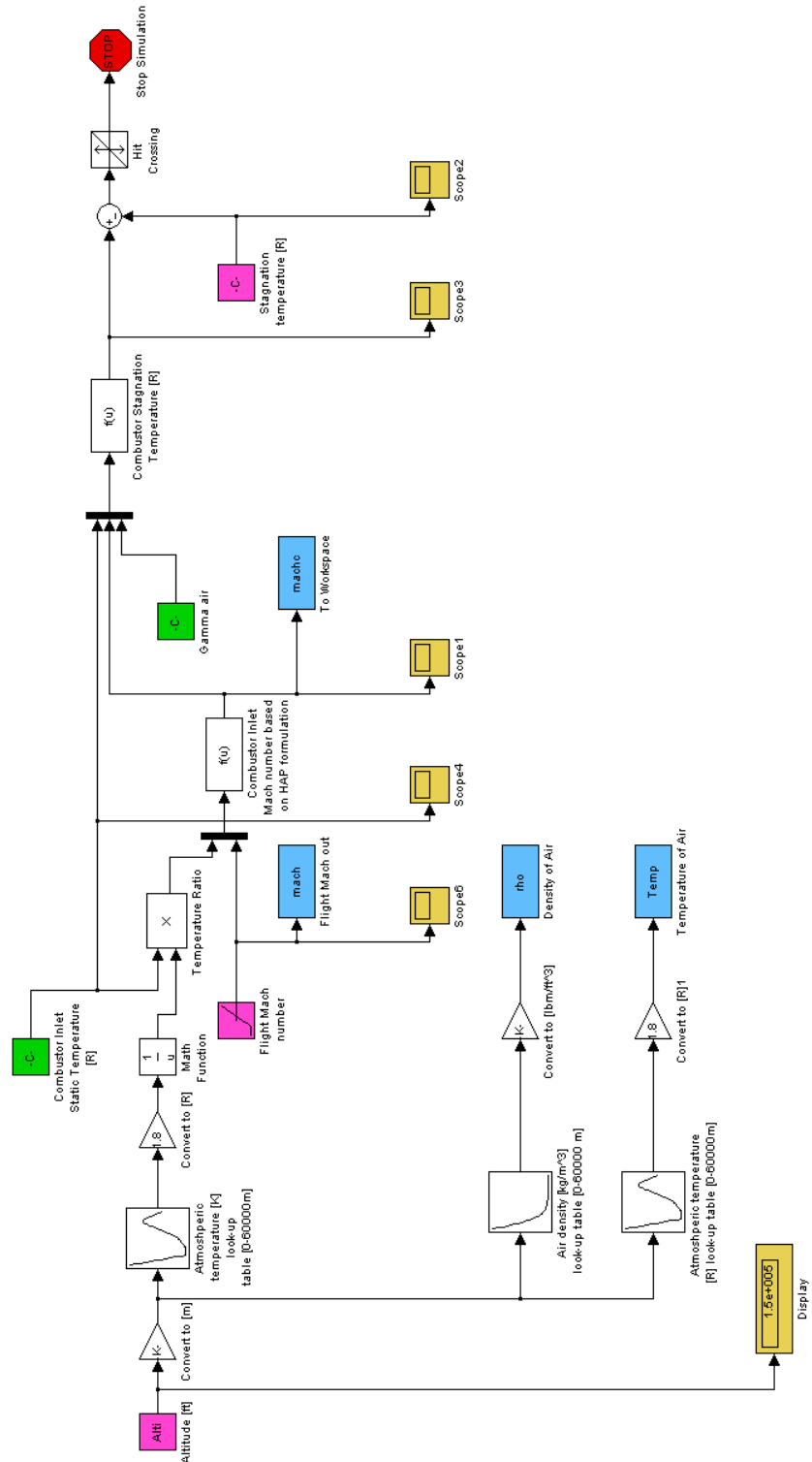

Figure 12. 'stagnationtemp' SIMULINK model

The 'stagnationtemp' model differs from the two models already considered because in this case the flight Mach number is the ramped input variable. This is due to the fact that the atmospheric temperature profile as a function of height has multiple altitude solutions for a given temperature value, as shown in figure (13).

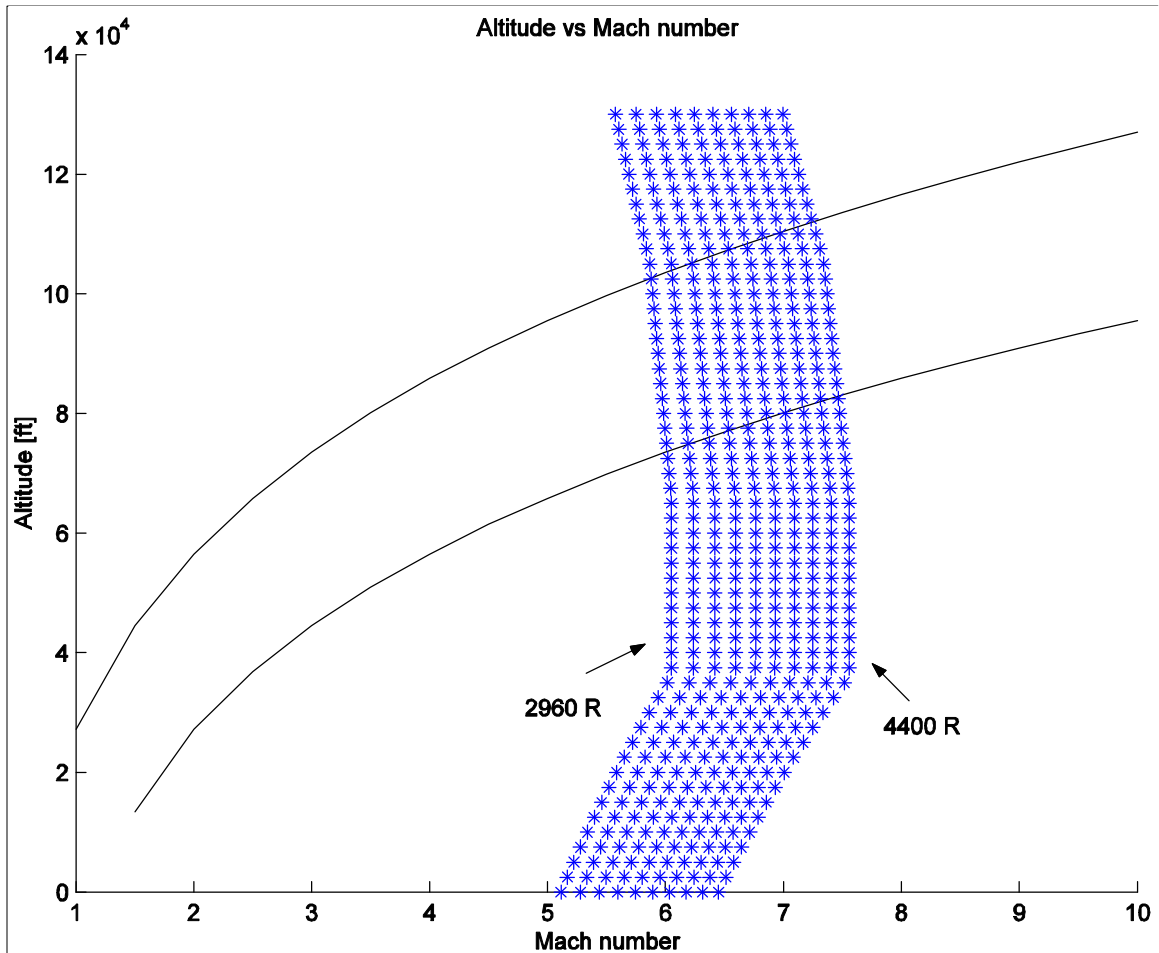

Figure 13. Lines of Constant Stagnation Temperature

This model has inner and outer iteration loops. The outer loop varies the stagnation temperature between the upper and lower limits defined at the beginning of the program. Also, the flight altitude is incremented from

zero to the altitude limit. The model performs a comparison between the calculated and reference values and terminates the iteration when a zero crossing is detected. The flight Mach number, combustion Mach number, atmospheric density, and atmospheric temperature are then output to the main MATLAB program. The altitude from the 'stagnationtemp' model was checked against the 'atmosphericsolver' solution of altitude for the dynamic pressures used to define the flight profile. If the altitude from the 'stagnationtemp' model is in the allowable range then a point is plotted on the figure, see figure (14). The combustor stagnation temperature is recorded and the combustor Mach number is evaluated to determine whether this value becomes the new limit for the supersonic area ratio calculation that is performed later in the program. The process was then repeated for all stagnation temperatures and for the respective altitudes up to the defined limit.

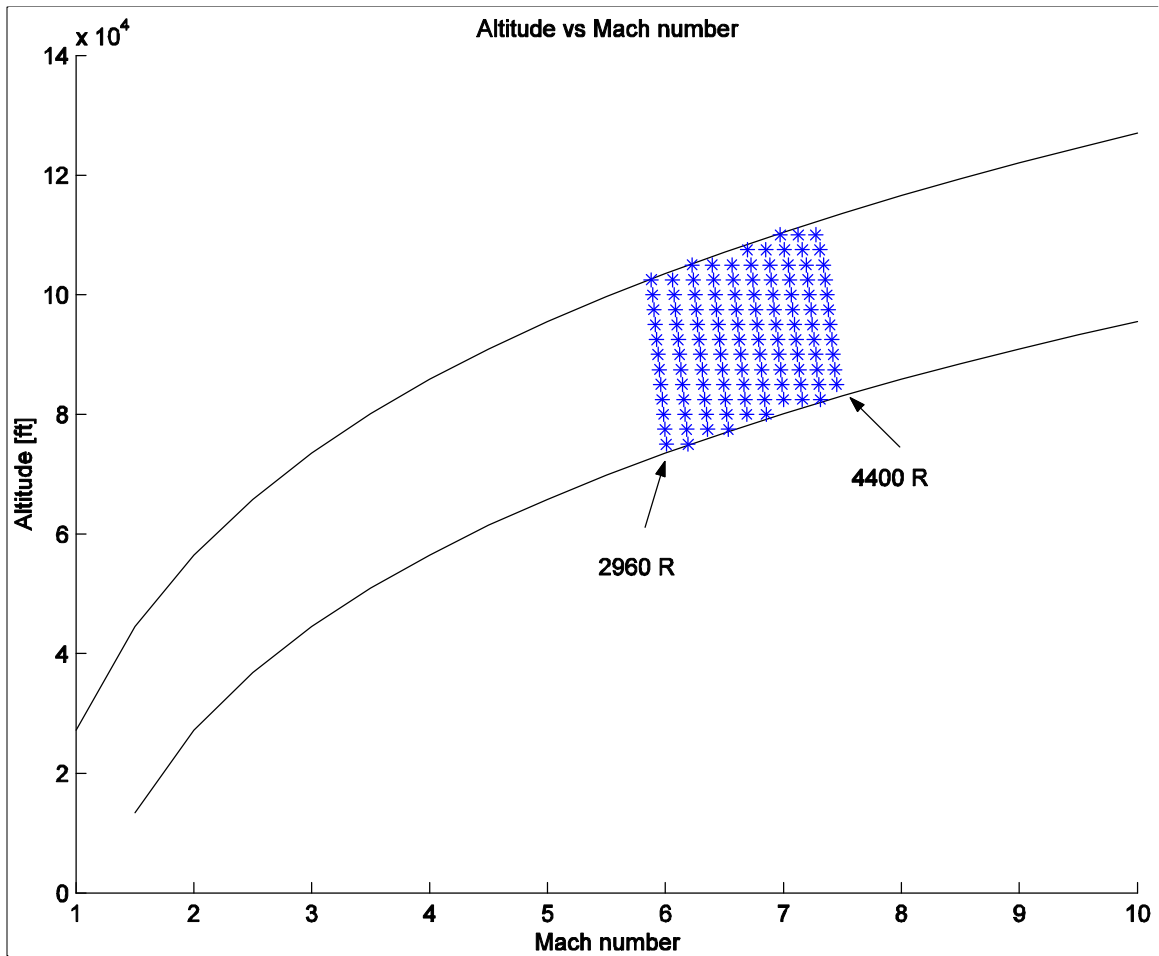

Figure 14. Lines of Constant Stagnation Temperature in the Flight Envelope

Combining the results for stagnation temperature and pressures at the combustor inlet creates a matrix of temperature and pressure conditions that define the region which is shown in the figure (15) below.

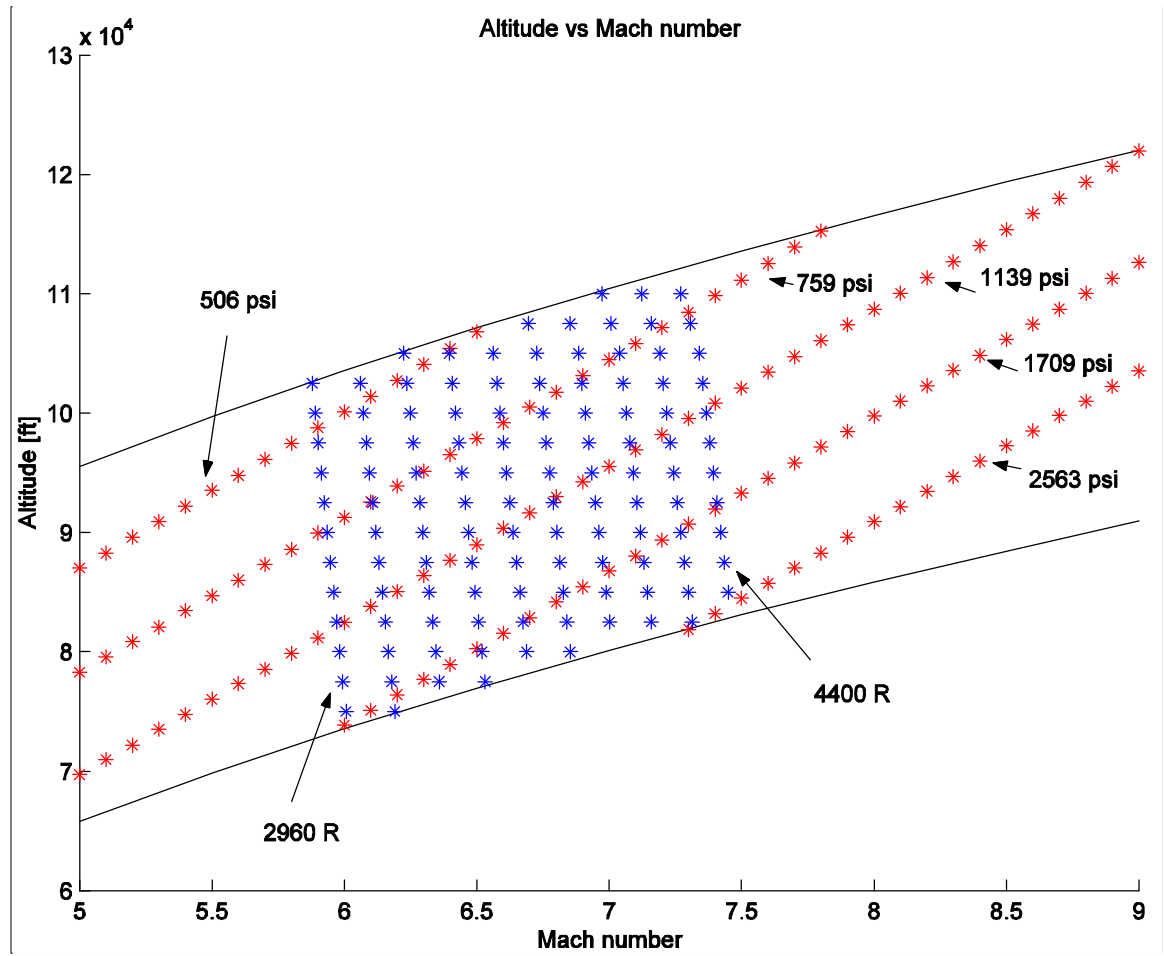

Figure 15. Close up of the Region of Operation

4. Choked Flow Calculator

The pressure values are used to determine choked system flow rates for each of the supply gases whose properties are defined by the user. For each gas system, the 'Chokedflowrate' SIMULINK model, shown in figure (16), determines the mass flow rates. The gas mass flow rate is supplied as the ramped input variable. Using equation (9), the choked flow equation, and the user defined supply system characteristics, the model iterates through mass flow rates until the zero crossing is detected and then stops. The mass flow rate is recorded and passed to the main MATLAB program. The process repeats for each gas system and the results form the flow rates upper boundary conditions.

CHOKED FLOW RATE CALCULATOR

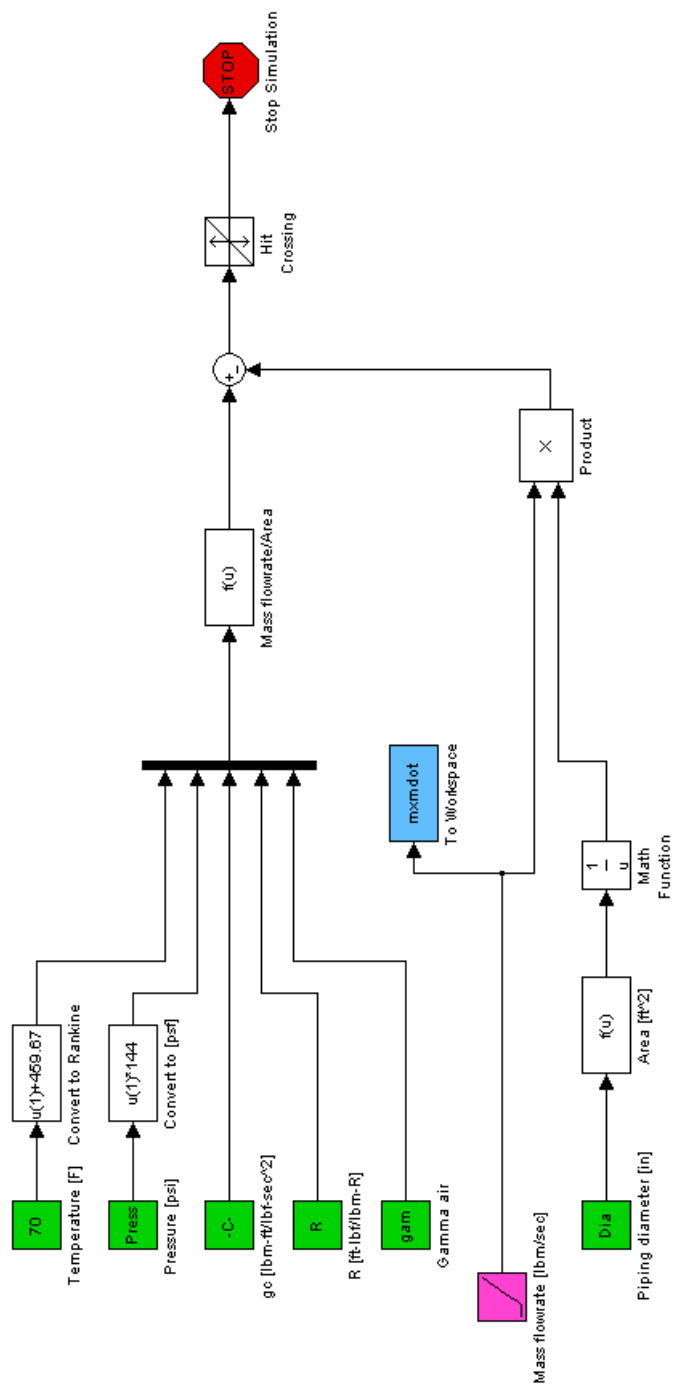

Figure 16. 'Chokedflowrate' SIMULINK model

5. Vitiator Flow Rates

Next, the 'Combustionflow' model represented in figure (17) is used to determine the mass flow rates required to generate the stagnation temperatures found in section (c). In this model, the pressure and temperature and the loop variables are applied to a series of look-up tables that determine the air mass concentration and Fuel/Air ratio needed to generate the specified temperature at the specified pressure. These values along with the air mass flow rate which is a ramped input are then used to calculate the required oxygen and hydrogen mass flow rates, used to generate the input temperature. The model will continue to increase the air mass flow rate until the air, hydrogen or oxygen mass flow rate reaches 80% of their respective choked flow values, which were found by the 'Chokedflowrate' model.

When the 'Combustionflow' model finishes all calculations, the final air, hydrogen and oxygen flow rates as well as the mixture gas constant (R_{mix}), mixture density (ρ_{mix}) and the ratio of specific heats for the mixture (γ_{mix}) are reported to the main program. If the O_2 or H_2 mass flow rates were the limiting factor then the corresponding air flow rate is assigned as the maximum air flow rate. However, if the 'Combustionflow' model calculations were not limited by the hydrogen and oxygen flow rate limitations, then the maximum air flow rate becomes 80% of the choked air system flow rate.

COMBUSTION OXIDIZER AND FUEL CALCULATOR

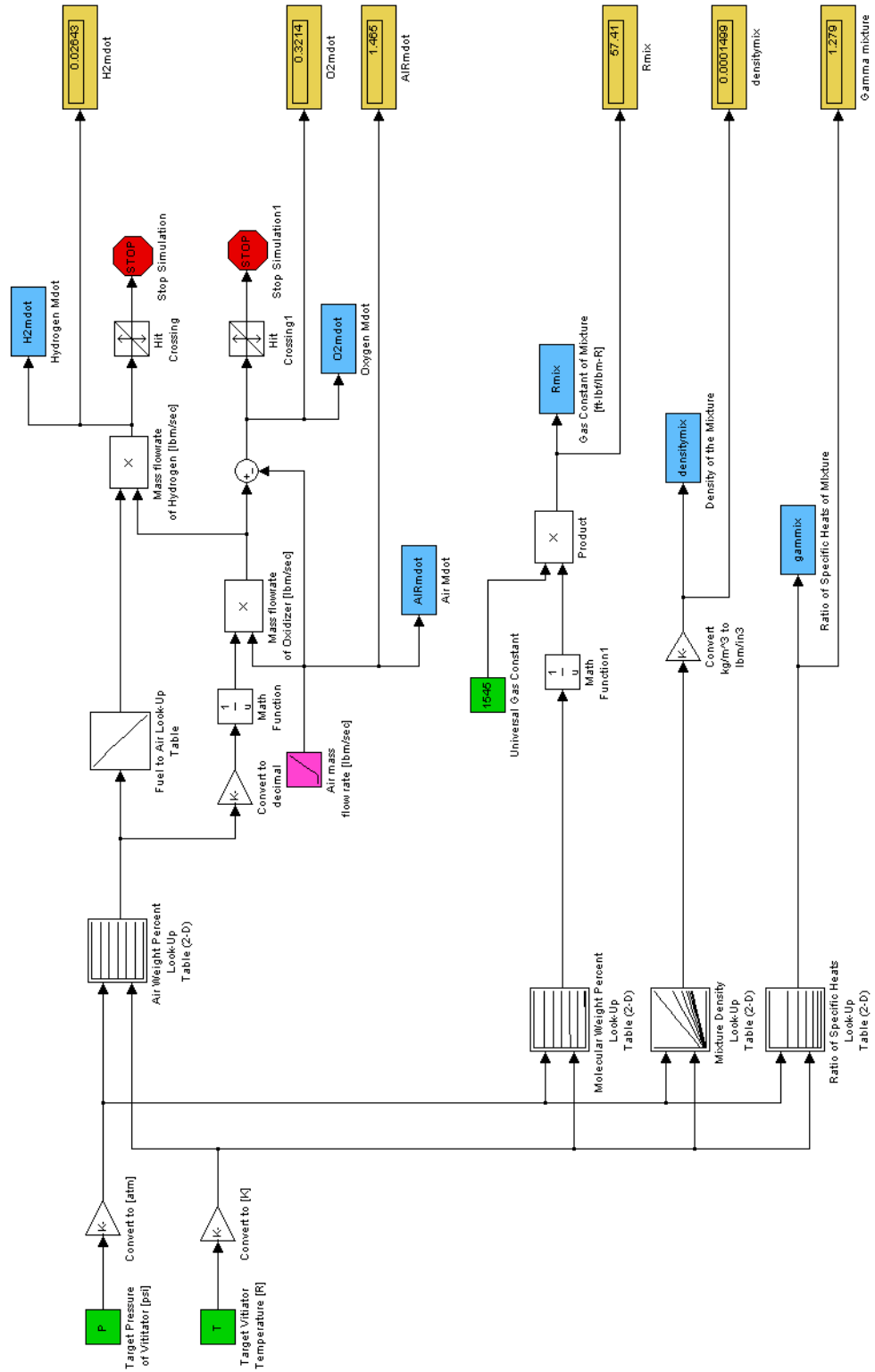

Figure 17. 'Combustionflow' SIMULINK model

6. Testing Time

The maximum air flow rate computed above is sent to the 'systemruntime' model shown in figure (18). Here, the air supply system parameters are applied to the maximum air flow rate determined by the 'Combustionflow' model. Specifically, the air supply tank volume is evaluated to find the amount of time the maximum air flow rate can be supplied, while maintaining the tank pressure above the minimum value as specified in the user variables section of the program. The target final tank pressure is found by adding 250 psi to the stagnation pressure loop variable (unless this sum exceeds the supply air tank pressure). The model then returns the calculated run time to the main MATLAB program.

At this point, the main program determines if the testing time is sufficient as discussed earlier in section I.B.2. If the run time does not meet the specification, another SIMULINK model, 'Makesystemruntime' shown in figure (19), is called to lower the air mass flow rate until the minimum testing time requirements are met.

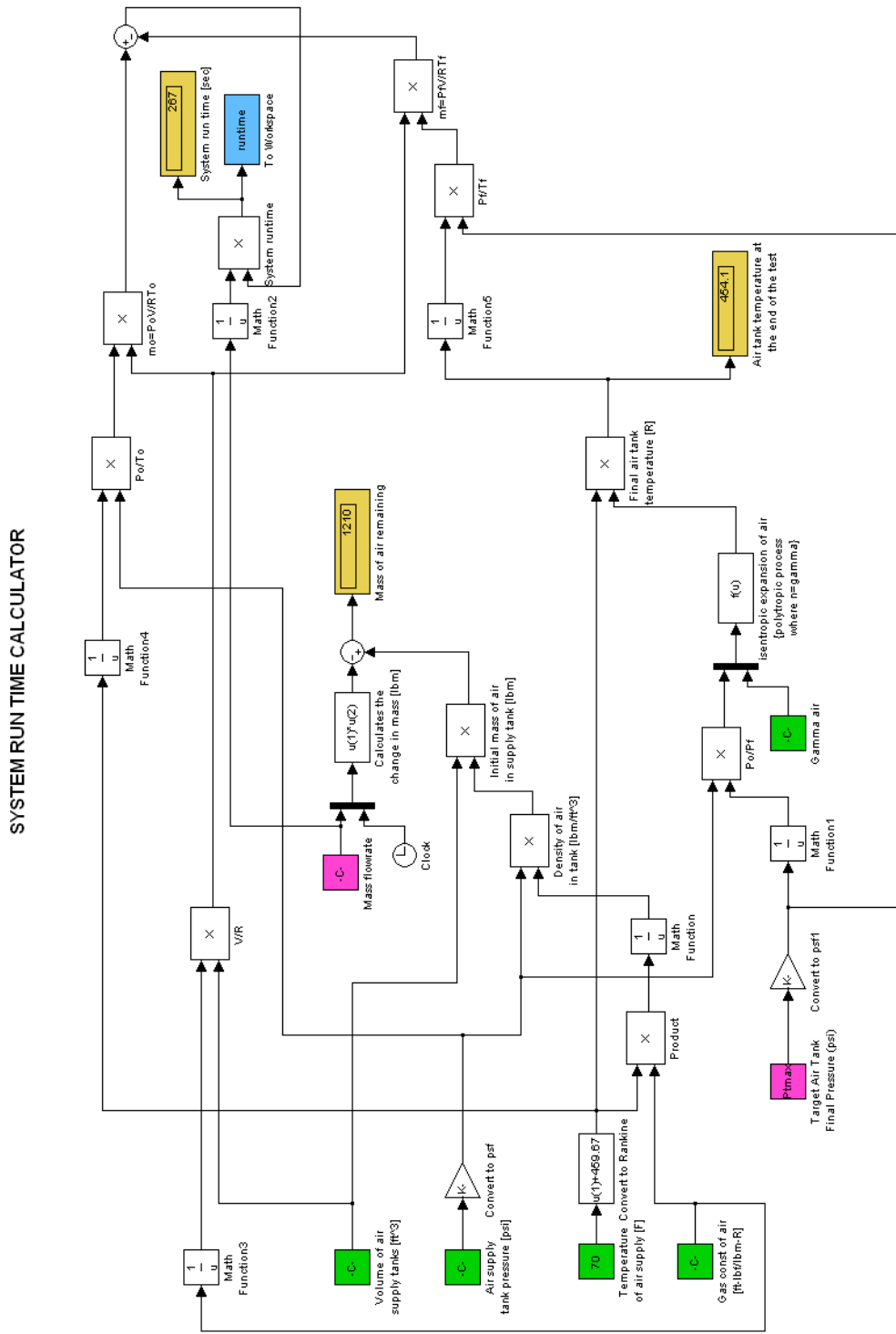

Figure 18. 'systemruntime' SIMULINK model

RUN TIME ADJUSTMENT CALCULATOR

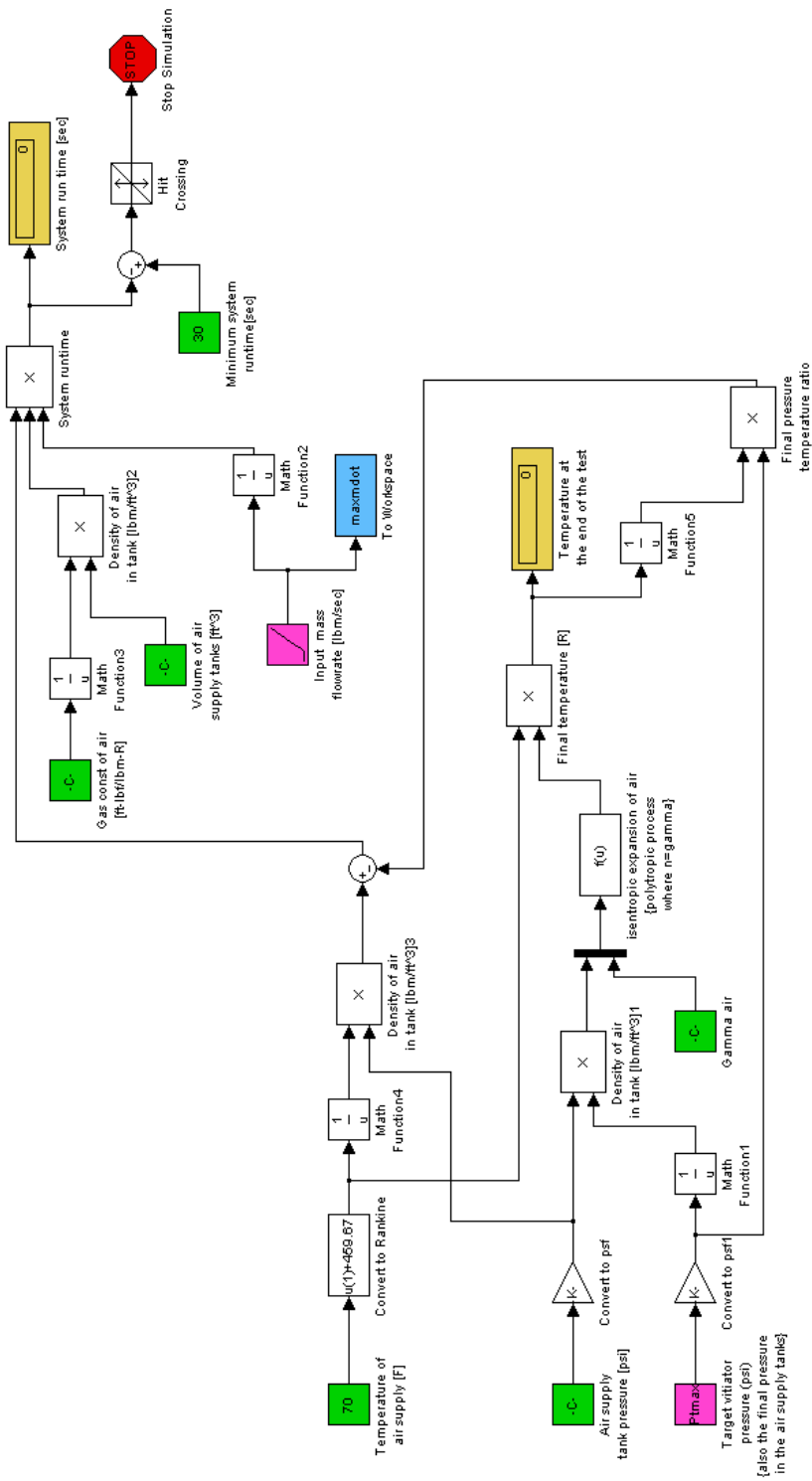

Figure 19. 'Makesystemruntime' SIMULINK model

7. Facility Nozzle Throat Area and Area Ratio

The final part of this program calculates the total mass flow rate and subsequently determines the facility nozzle parameters. The program sums the mass flow rates of the three gases, H_2 , O_2 and Air to determine the total mass flow rate that the facility nozzle will experience.

Since this is a choked condition at the facility nozzle throat, once again equation (9) is used. In this model, equation (9) is solved for throat area. The value is stored by the program in the 'Astar' matrix. The next step uses the 'findmyexitmachnumber' model shown in figure (20). This model uses a reference input for area ratio, and then applies Newton's method to solve for the exit Mach number. When the matching Mach number is found the model stops and returns the exit Mach number to the main program. The process is then repeated for each of stagnation pressure and temperature conditions that were found to be valid in the atmosphere modeling process.

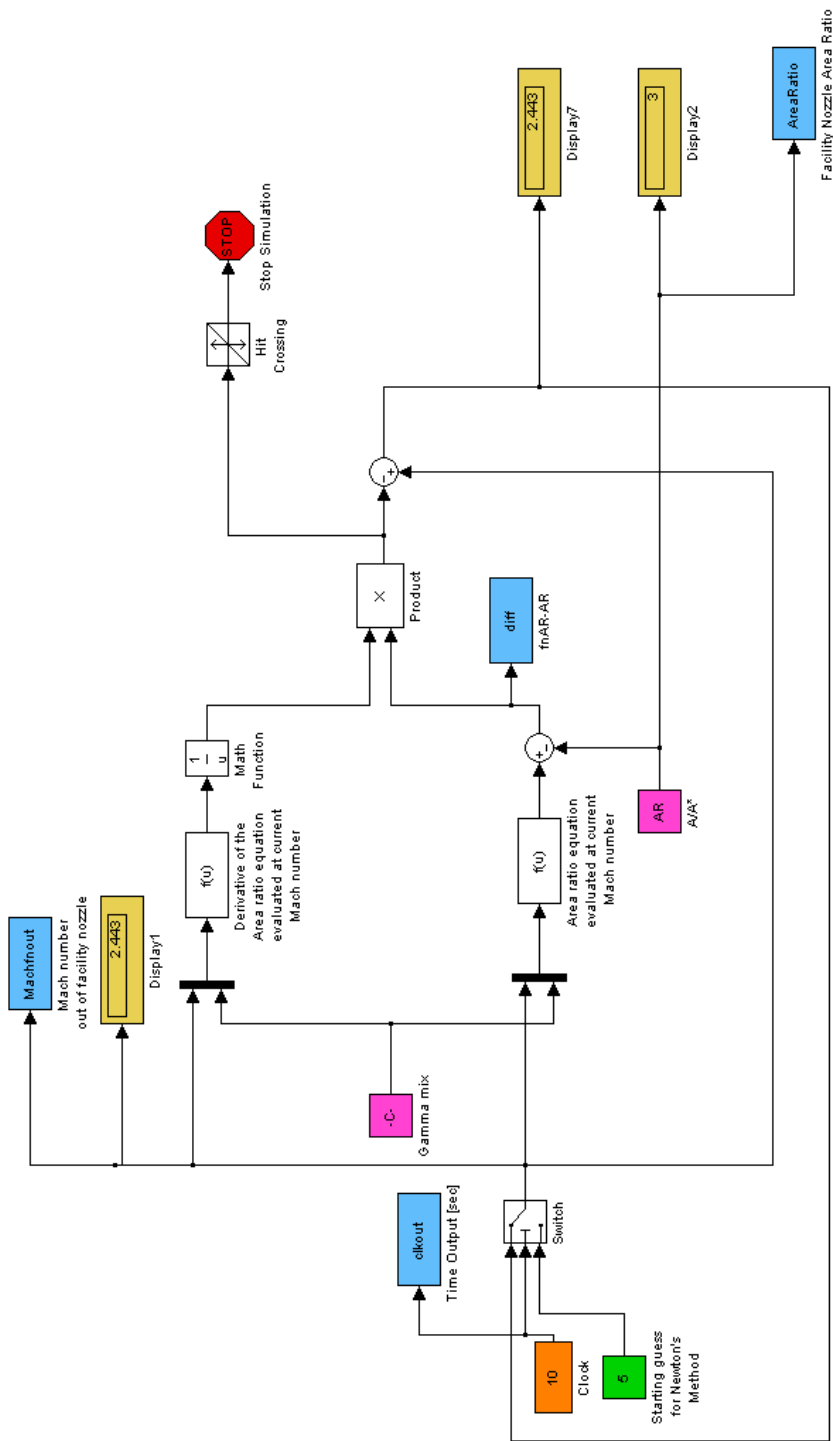

Figure 20. 'findmyexitmachnumber' SIMULINK model

IV. RESULTS

A. AIR PRESSURE SOURCE

Several series of calculations were performed to determine the combustor inlet stagnation pressures. These calculations, depicted in figure (21), show that the maximum combustor stagnation pressure that occurs in the dynamic pressure flight window ranges roughly from 340 to 2560 psi for the region of concern (flight Mach numbers 1 to 10).

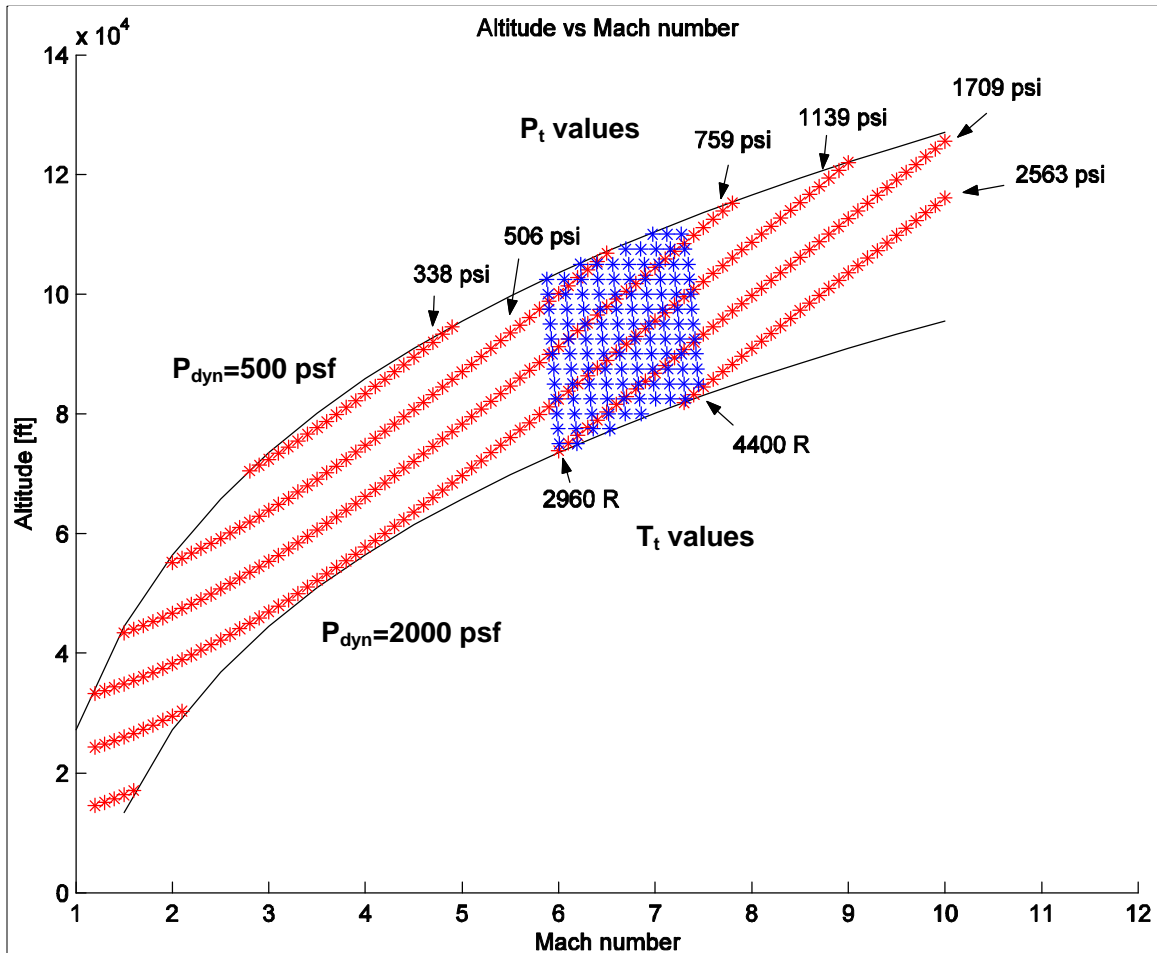

Figure 21. Region of Operation in the Flight Window

The graph above shows the black dynamic pressure lines forming a flight envelope dotted with red and blue asterisks.

The upper black line represents a dynamic pressure of 500 psf and the lower one is 2000 psf. The red "lines" are lines of constant stagnation pressure. The blue lines are lines of constant stagnation temperature. The upper red line is 340 psi and the lowest "broken" red line is about 2560 psi combustor stagnation pressure. One aspect of the graph that should not be overlooked is that at a stagnation pressure (P_t) of 2563 psi, the full dynamic pressure ($P_{dynamic}$) window (from 500 to 2000 psf) can be replicated up to nearly Mach 7.5. Also the most restrictive condition of 337.5 psi and 4400 °R and the mass flow rate is limited by a choked oxygen system flow. The corresponding air flow rate was determined to be about 17.1 lbm/s, which yields a test time of about 4 s. As discussed earlier, the minimum acceptable run time was set at 30 s. To achieve this minimum run time value without changing the piping systems, the air tanks would have to be 8 times larger than the current size if the air mass flow rate was kept at 17.1 lbm/s. Conversely if the air supply volume were kept constant, the air flow rate would have to be reduced to 1.9 lbm/s to achieve 30 s test time. Reducing the mass flow rate by installing an orifice in the air supply line is certainly the cheapest solution in the short run but the reduction in system mass flow rate would require a smaller prototype combustor. A smaller combustor would introduce other problems that could lead to inaccurate test results.

In order to minimize the cost and avoid some of the problems involved with very small scale modeling, a

compromise is proposed. If the volume of the air tanks is doubled, then the air system mass flow can be doubled to nearly 4 lbm/sec, and because the air mass flow rate at this temperature was only 65% by weight of the oxidizer, the total mass flow rate was about 6 lbm/sec.

By increasing air storage volume, the RPCL would be able to perform hypersonic testing throughout the dynamic pressure flight window.

B. VITIATOR DESIGN

The design of a vitiated heater is without a doubt the most challenging part of this design. In the case of the RPCL design, the vitiator must be able to safely contain 2560 psi and heat the air to 4400 °R. A cooled vitiator is necessary. One design is discussed by Hashimoto and Yoshida (Ref. 12). Their model was proven to operate at about 4 lbm/sec, 3000 °R and nearly 900 psi. While these conditions are not sufficient to support the conditions desired in this proposal, the temperature distribution profile was of interest. Specifically with a relatively small design they showed a 5-15% temperature stability in a short mixing distance. This was achieved by injecting the O₂ and H₂ through 8 injectors. They also designed the hydrogen and oxygen flow rates to be injected at different velocities, which results in shorter lengths to achieve macroscopic mixing. This success proves their design process and will aid in the design of a vitiator for the NPS hypersonic test stand.

C. FACILITY NOZZLE

The facility nozzle design is one feature of the NPS test stand that will need to be adjustable, or several different nozzles will need to be available to support testing at different Mach numbers. This is due to the fact that the maximum total mass flow rate (not including test time restrictions) that RPCL can support was found to vary from about 3 to 45 lbm/sec, as shown in figure (22), over the entire dynamic flight window.

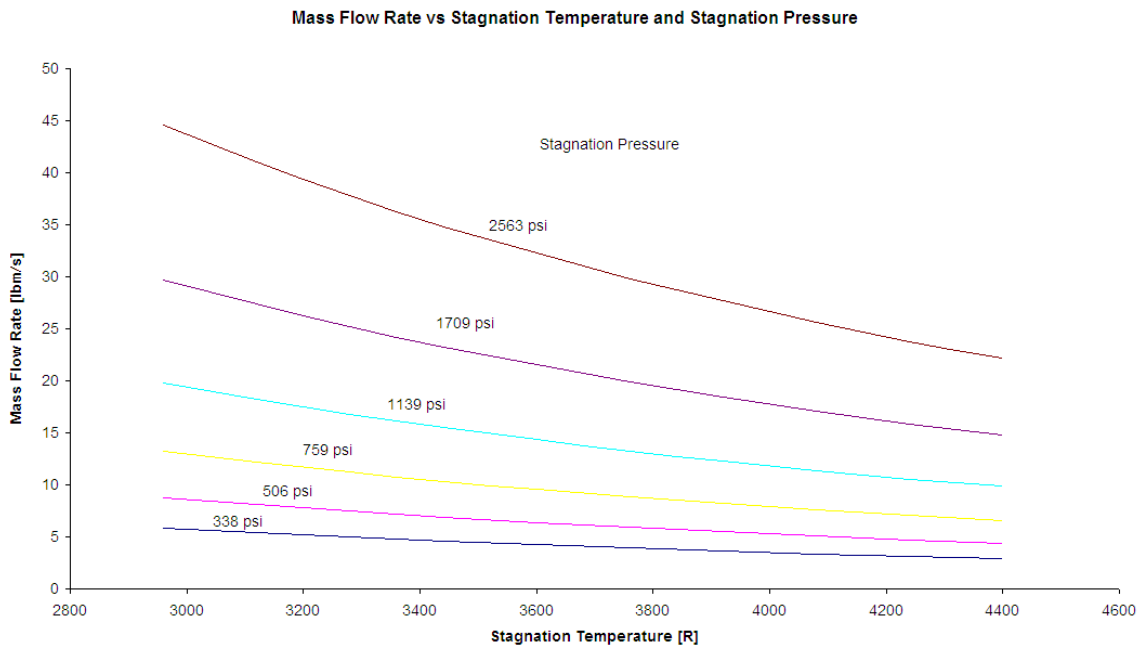

Figure 22. Mass Flow Rates versus Stagnation Temperatures at various Stagnation Pressures

This resulted in correspondingly large variations in facility nozzle throat area, A^* . Finally, the variation of A^* at a constant mass flow rate was determined. The lowest system flow rate was used to normalize each ratio of mass flow rate to A^* . Figure (23) shows that for the most restrictive condition, which corresponds to the lowest P_t and highest T_t , (337.5 psi and 4400 R), the facility nozzle

throat area varies by less than 0.03 in. This small variation will allow for the proposal of a facility nozzle design that consists of a common converging section with modular diverging extensions to allow for the supersonic area ratio to be adjusted to meet the exit Mach number requirements.

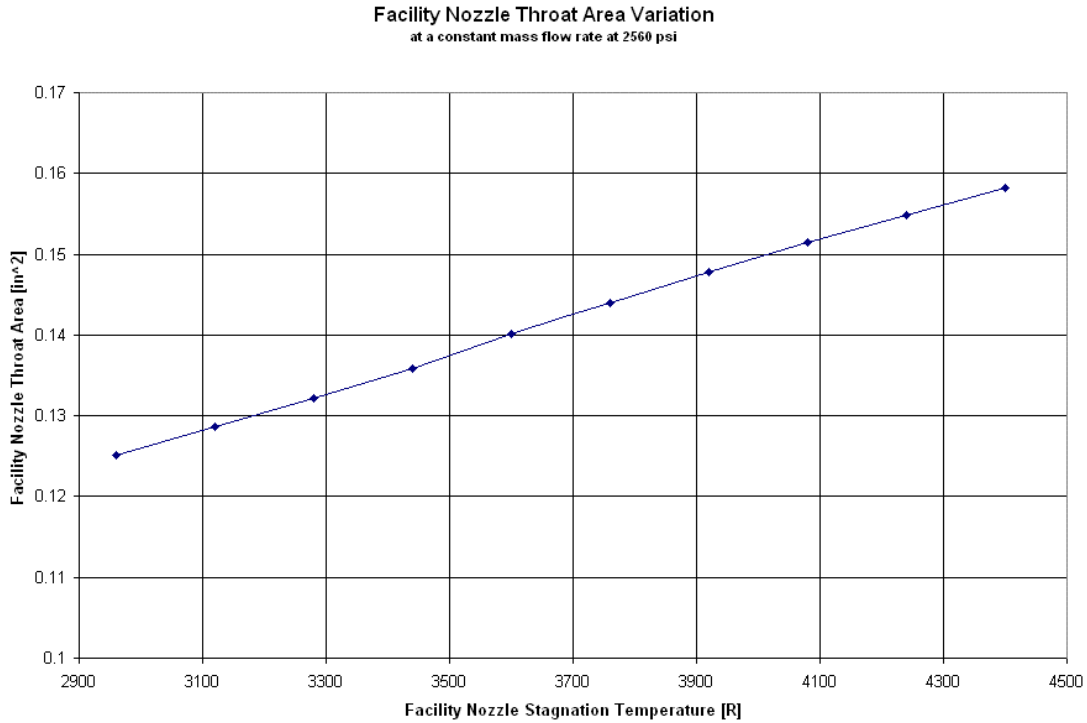

Figure 23. Facility Nozzle Throat Area Variation

THIS PAGE INTENTIONALLY LEFT BLANK

V. CONCLUSION

In order to support a hypersonic blow-down facility at NPS' RPCL, the air supply tank volume needs to be increased by at least 100% of its current capacity, (which is 160 ft³ at 3000 psi, or over 32,500 ft³ of air at STP). This will allow testing of scramjet engines throughout a dynamic pressure flight envelope of 500 to 2000 psf in the Mach number range of 5 to 7.5. Additionally, the installed regulator will need to be bypassed to achieve stagnation pressures greater than 1000 psi.

A method was developed and used to perform this evaluation. This method was implemented into a software suite developed to perform the calculations allowing the user to access multiple parameters and investigate the proposed hardware system changes to the design results.

The preliminary requirements for the vitiator and facility nozzle were also found and basic solution concepts were proposed. A vitiator heater design burning H₂ and O₂ with evenly spaced multiple gas injection ports will generate the uniform temperature profile that is needed for this testing. Also since there are only small variations in the nozzle throat conditions, a modularized facility nozzle design is feasible, with diverging section extensions to allow the target exit Mach number to be adjusted.

With minor support system modifications, the reality of a hypersonic test facility is within reach.

THIS PAGE INTENTIONALLY LEFT BLANK

```

figure(1);
title('Altitude vs Mach number');
xlabel('Mach number');
ylabel('Altitude [ft]');
hold on

for i=1:length(dynamp);
    dynampress=dynamp(i);
    j=1;Mach=[];alt=[];
    for M=1:0.5:flightMmax;
        sim('atmosphericsolver');
        if altout(end)<altmax; % Time limit of solver, if true then a
solution was found
            Mach(j)=M;alt(j)=altout(end);
            j=j+1;
        end
    end
    plot(Mach,alt,'k');
end

stagpress=stagplow;i=1;
while stagpress<=Pairtank;
    for M=1:0.1:flightMmax;
        sim('Stagnationpressure');
        dynampress=500;
        sim('atmosphericsolver');
        highlimit=altout(end);
        dynampress=2000;
        sim('atmosphericsolver');
        lowlimit=altout(end);
        if altoutp(end)<highlimit&altoutp(end)>lowlimit;
            if i==1;
                stagp(i)=stagpress;
                i=i+1;
            end
            if i>1&stagpress>stagp(i-1); % Records the stagnation
pressures that fall within the defined flight window
                stagp(i)=stagpress;
                i=i+1;
            end
            plot(M,altoutp(end),'r*');
            if machc(end)>machcmax;
                machcmax=machc(end); % For the flight window this
specifies the maximum Combustor Mach number
            end
        end
    end
    stagpress=1.5*stagpress;
end

stagtemp=stagtlow;i=1;
while stagtemp<=stagthigh;
    for Alti=0:2500:altmax;
        sim('Stagnationtemperaturebetter');
        if mach(end)<flightMmax; % Solution found if true, limit of
solver and valid combustor Mach number
            M=mach(end);

```



```

% Calculates the O2 and H2 flow rates required to give the
desired vitiator temperatures %
% and returns the density of the mixture

%%%%%%%%%%%%%%%%%%%%%%%%%%%%%%%%%%%%%%%%%%%%%%%%%%%%%%%%%%%%%%%%%%%%%%%%
%%%%%%%%%%%%%%%%%%%%%%%%%%%%%%%%%%%%%%%%%%%%%%%%%%%%%%%%%%%%%%%%%%%%%%%%
sim('Combustionflow');

%%%%%%%%%%%%%%%%%%%%%%%%%%%%%%%%%%%%%%%%%%%%%%%%%%%%%%%%%%%%%%%%%%%%%%%%
%%%%%%%%%%%%%%%%%%%%%%%%%%%%%%%%%%%%%%%%%%%%%%%%%%%%%%%%%%%%%%%%%%%%%%%%

%%%%%%%%%%%%%%%%%%%%%%%%%%%%%%%%%%%%%%%%%%%%%%%%%%%%%%%%%%%%%%%%%%%%%%%%
%%%%%%%%%%%%%%%%%%%%%%%%%%%%%%%%%%%%%%%%%%%%%%%%%%%%%%%%%%%%%%%%%%%%%%%%
% Calculates the total system runtime given the upper limit
on mass flow rate given above %

%%%%%%%%%%%%%%%%%%%%%%%%%%%%%%%%%%%%%%%%%%%%%%%%%%%%%%%%%%%%%%%%%%%%%%%%
%%%%%%%%%%%%%%%%%%%%%%%%%%%%%%%%%%%%%%%%%%%%%%%%%%%%%%%%%%%%%%%%%%%%%%%%
Ptmax=P;
if Pairtank>=P+250;
Ptmax=P+250;
end
sim('systemruntime');
if runtime(end)<30;
sim('Makesystemruntime');% If this model is called then it
will calculate a new maximum air flowrate to allow 30 sec of run time
maximummdot=mxmdot(end);
end

%%%%%%%%%%%%%%%%%%%%%%%%%%%%%%%%%%%%%%%%%%%%%%%%%%%%%%%%%%%%%%%%%%%%%%%%
%%%%%%%%%%%%%%%%%%%%%%%%%%%%%%%%%%%%%%%%%%%%%%%%%%%%%%%%%%%%%%%%%%%%%%%%
% This section is for the design of the facility nozzle is
%
% the beginning of the process for designing the system.
%

%%%%%%%%%%%%%%%%%%%%%%%%%%%%%%%%%%%%%%%%%%%%%%%%%%%%%%%%%%%%%%%%%%%%%%%%
%%%%%%%%%%%%%%%%%%%%%%%%%%%%%%%%%%%%%%%%%%%%%%%%%%%%%%%%%%%%%%%%%%%%%%%%
totalmassdot(x,y)=AIRmdot(end)+O2mdot(end)+H2mdot(end);

%%%%%%%%%%%%%%%%%%%%%%%%%%%%%%%%%%%%%%%%%%%%%%%%%%%%%%%%%%%%%%%%%%%%%%%%
%%%%%%%%%%%%%%%%%%%%%%%%%%%%%%%%%%%%%%%%%%%%%%%%%%%%%%%%%%%%%%%%%%%%%%%%
% Find the throat Area that will support the target flowrate
found above %

%%%%%%%%%%%%%%%%%%%%%%%%%%%%%%%%%%%%%%%%%%%%%%%%%%%%%%%%%%%%%%%%%%%%%%%%
%%%%%%%%%%%%%%%%%%%%%%%%%%%%%%%%%%%%%%%%%%%%%%%%%%%%%%%%%%%%%%%%%%%%%%%%

Astar(x,y)=totalmassdot(x,y)*sqrt(T)/((gammix(end)*gc/Rmix(end))*(2/(gammix(end)+1))^(gammix(end)+1)/(gammix(end)-1))^0.5)/P;
DATA DUMP!!!!
Machfnout=1.1;AR=1.0;
for AR=3;
sim('findmyexitmachnum');
end
ExitMN(x,y)=Machfnout(end);

```

```
end
end
```

```
%%%%%%%%%%%%%%%%%%%%%%%%%%%%%%%%%%%%%%%%%%%%%%%%%%%%%%%%%%          NOTES:  TO  THE  USER
%%%%%%%%%%%%%%%%%%%%%%%%%%%%%%%%%%%%%%%%%%%%%%%%%%%%%%%%%%
% Astar - contains the various facility nozzle throat area [in^2] for
the conditions in the flight window
% ExitMN - for each calculated condition the AR to get a certain Mach
number
% MDOTAIR, MDOTH2, MDOTO2 - contain the flowrates required to meet Pt,
Tt conditions.
% totalmassdot - has the total system mass flow rate
%%%%%%%%%%%%%%%%%%%%%%%%%%%%%%%%%%%%%%%%%%%%%%%%%%%%%%%%%%
%%%%%%%%%%%%%%%%%%%%%%%%%%%%%%%%%%%%%%%%%%%%%%%%%%%%%%%%%%
```

THIS PAGE INTENTIONALLY LEFT BLANK

APPENDIX B. TEP COMBUSTION DATA

Pressure	120 atm		=1750 psi																		
	Air weight %	F/A ratio	Temp [K]	Temp [F]	Density[g/L]	Gamma	a [m/s]	O ₂ %	+1/3 percent deviation	-1/3 percent deviation	Molecular Weight										
	95	0.00425	768	1382.4	53.8	1.3493	552	21.0475	21.05	20.95	28.259										
	90	0.0084	1157	2082.6	35	1.3113	674.4	20.9982	21.05	20.95	27.706										
	85	0.0124	1484	2671.2	26.8	1.2885	762.8	21.03	21.05	20.95	27.202										
	80	0.0164	1771	3187.8	22.1	1.272	833.6	20.9817	21.05	20.95	26.719										
	75	0.02025	2016	3628.8	19.1	1.2596	890	20.9694	21.05	20.95	26.272										
	70	0.024	2227	4008.6	17	1.2498	936.6	20.9614	21.05	20.95	25.849										
	65	0.0276	2407	4332.6	15.5	1.2419	975.2	21.0145	21.05	20.95	25.45										
Pressure	102 atm		=1500 psi																		
	Air weight %	F/A ratio	Temp [K]	Temp [F]	Density[g/L]	Gamma	a [m/s]	O ₂ %	+1/3 percent deviation	-1/3 percent deviation	Molecular Weight										
	95	0.00425	768	1382.4	45.8	1.3493	552	21.0475	21.05	20.95	28.259										
	90	0.0084	1157	2082.6	29.8	1.3113	674.4	20.9985	21.05	20.95	27.706										
	85	0.0124	1484	2671.2	22.8	1.2885	762.8	21.0304	21.05	20.95	27.202										
	80	0.0164	1771	3187.8	18.7	1.272	833.6	20.982	21.05	20.95	26.718										
	75	0.02025	2016	3628.8	16.2	1.2596	889.9	20.9691	21.05	20.95	26.272										
	70	0.024	2227	4008.6	14.4	1.2498	936.4	20.9593	21.05	20.95	25.847										
	65	0.0276	2405	4329	13.2	1.2419	974.8	21.0097	21.05	20.95	25.447										
Pressure	85 atm		=1250 psi																		
	Air weight %	F/A ratio	Temp [K]	Temp [F]	Density[g/L]	Gamma	a [m/s]	O ₂ %	+1/3 percent deviation	-1/3 percent deviation	Molecular Weight										
	95	0.00425	768	1382.4	38.1	1.3493	552	21.0475	21.05	20.95	28.259										
	90	0.0084	1157	2082.6	24.8	1.3113	674.4	20.9987	21.05	20.95	27.706										
	85	0.0124	1484	2671.2	19.1	1.2885	762.8	21.0309	21.05	20.95	27.202										
	80	0.0164	1771	3187.8	15.6	1.272	833.6	20.9824	21.05	20.95	26.718										
	75	0.02025	2016	3628.8	13.5	1.2596	889.8	20.9685	21.05	20.95	26.271										
	70	0.024	2226	4006.8	12	1.2498	936.1	20.9567	21.05	20.95	25.846										
	65	0.0276	2404	4327.2	11	1.242	974.3	21.0039	21.05	20.95	25.445										
Pressure	68 atm		=1000 psi																		
	Air weight %	F/A ratio	Temp [K]	Temp [F]	Density[g/L]	Gamma	a [m/s]	O ₂ %	+1/3 percent deviation	-1/3 percent deviation	Molecular Weight										
	95	0.00425	768	1382.4	30.5	1.3493	552	21.0476	21.05	20.95	28.259										
	90	0.0084	1157	2082.6	19.8	1.3113	674.4	20.9989	21.05	20.95	27.706										
	85	0.0124	1484	2671.2	15.2	1.2885	762.8	21.0313	21.05	20.95	27.202										
	80	0.0164	1771	3187.8	12.5	1.272	833.5	20.9827	21.05	20.95	26.718										
	75	0.02025	2016	3628.8	10.8	1.2596	889.6	20.9677	21.05	20.95	26.27										
	70	0.024	2225	4005	9.62	1.2498	935.7	20.9532	21.05	20.95	25.844										
	65	0.0276	2403	4325.4	8.78	1.2421	973.7	20.9963	21.05	20.95	25.441										
Pressure	51 atm		=750 psi																		
	Air weight %	F/A ratio	Temp [K]	Temp [F]	Density[g/L]	Gamma	a [m/s]	O ₂ %	+1/3 percent deviation	-1/3 percent deviation	Molecular Weight										
	95	0.00425	768	1382.4	22.9	1.3493	552	21.0476	21.05	20.95	28.259										
	90	0.0084	1157	2082.6	14.9	1.3113	674.4	20.9992	21.05	20.95	27.706										
	85	0.0124	1484	2671.2	11.4	1.2885	762.8	21.0319	21.05	20.95	27.202										
	80	0.0164	1771	3187.8	9.38	1.272	833.5	20.9829	21.05	20.95	26.718										
	75	0.02025	2015	3627	8.1	1.2596	889.4	20.9662	21.05	20.95	26.269										
	70	0.024	2224	4003.2	7.22	1.2499	935.2	20.9481	21.05	20.95	25.842										
	65	0.0276	2400	4320	6.59	1.2422	972.9	20.9856	21.05	20.95	25.437										
Pressure	34 atm		=500 psi																		
	Air weight %	F/A ratio	Temp [K]	Temp [F]	Density[g/L]	Gamma	a [m/s]	O ₂ %	+1/3 percent deviation	-1/3 percent deviation	Molecular Weight										
	95	0.00425	768	1382.4	15.3	1.3493	552	21.0477	21.05	20.95	28.259										
	90	0.0084	1157	2082.6	9.92	1.3113	674.4	20.9996	21.05	20.95	27.706										
	85	0.0124	1484	2671.2	7.6	1.2885	762.8	21.0324	21.05	20.95	27.202										
	80	0.0164	1771	3187.8	6.25	1.272	833.4	20.983	21.05	20.95	26.717										
	75	0.02025	2014	3625.2	5.4	1.2597	889.1	20.9637	21.05	20.95	26.268										
	70	0.024	2223	4001.4	4.82	1.25	934.5	20.9397	21.05	20.95	25.839										
	65	0.0276	2397	4314.6	4.4	1.2423	971.5	20.9689	21.05	20.95	25.429										
Pressure	17 atm		=250 psi																		
	Air weight %	F/A ratio	Temp [K]	Temp [F]	Density[g/L]	Gamma	a [m/s]	O ₂ %	+1/3 percent deviation	-1/3 percent deviation	Molecular Weight										
	95	0.00425	768	1382.4	7.63	1.3493	552	21.0478	21.05	20.95	28.259										
	90	0.0084	1157	2082.6	4.96	1.3113	674.4	21	21.05	20.95	27.706										
	85	0.0124	1484	2671.2	3.8	1.2885	762.8	21.0331	21.05	20.95	27.202										
	80	0.0164	1771	3187.8	3.13	1.272	833.2	20.9824	21.05	20.95	26.716										
	75	0.02025	2013	3623.4	2.7	1.2597	888.4	20.9577	21.05	20.95	26.266										
	70	0.024	2219	3994.2	2.41	1.2501	932.9	20.9224	21.05	20.95	25.832										
	65	0.0276	2390	4302	2.2	1.2426	968.9	20.9357	21.05	20.95	25.415										

THIS PAGE INTENTIONALLY LEFT BLANK

LIST OF REFERENCES

1. Schafer, M.D., "Feasibility of SCRAMJET Technology for an Intermediate Propulsive Stage of an Expendable Launch Vehicle," Thesis(M.S. in Space Systems Operation.) Naval Postgraduate School, September 2002.
2. Lu, F.K., and Marren, D.E., Advanced Hypersonic Test Facilities. Progress in Astronautics and Aeronautics Series, *American Institute of Aeronautics and Astronautics*, 2002. ISBN: 1-56347-541-3.
3. Heiser, W.H., and Pratt, D.T., Hypersonic Airbreathing Propulsion., AIAA Inc., Washington, D.C., 1994.
4. Pietrobon, S.S., ussa1976.exe, (Computerized version of the U.S. Standard Atmosphere Tables).
5. Pope, A., and Goin, K.L., High-Speed Wind Tunnel Testing. John Wiley and Sons, Inc., New York, NY. 1965.
6. Zucker, R.D., and Biblarz, O., Fundamentals of Gas Dynamics (second edition). John Wiley & Sons, Inc., Hoboken, NJ. 2002.
7. Burden, R.L. and Faires, J.D., Numerical Analysis, Fifth Edition. PWS Kent Publishing Co., Boston, 1993.
8. Penner, S.S., International Series of Monographs on Aeronautical Sciences and Space Flight. Pergamon Press, New York, NY. 1957.
9. Personal Communication with Dr. Chinitz, March 2003.
10. Using SIMULINK. The MathWorks Inc, 2000.
11. Wood, B.D., Applications of Thermodynamics. Waveland Press, Inc., Prospect Heights, IL. 1991.
12. Hashimoto, T., and Yoshida, M., "Development of a Vitiated Air Heater for Engine Test Facilities", AIAA 91-2501-CP.

THIS PAGE INTENTIONALLY LEFT BLANK

INITIAL DISTRIBUTION LIST

1. Defense Technical Information Center
Ft. Belvoir, Virginia
2. Dudley Knox Library
Naval Postgraduate School
Monterey, California
3. Dr. Jose O. Sinibaldi
Naval Postgraduate School
Monterey, California
4. Dr. Garth V. Hobson
Naval Postgraduate School
Monterey, California
5. Dr. Wallace Chinitz
GASL
Ronkonkoma, New York