

AD

AD-E403 003

Technical Report ARQED-TR-03007

## SPECIAL STUDY OF THE ENVIRONMENTAL EFFECTS ON STORAGE LIFE

Brian T. Pope  
Michael J. Cassiello

February 2004



ARMAMENT RESEARCH, DEVELOPMENT AND  
ENGINEERING CENTER

Quality Engineering & System Assurance

Picatinny, New Jersey

Approved for public release; distribution is unlimited.

20040303 301

The views, opinions, and/or findings contained in this report are those of the author(s) and should not be construed as an official Department of the Army position, policy, or decision, unless so designated by other documentation.

The citation in this report of the names of commercial firms or commercially available products or services does not constitute official endorsement by or approval of the U.S. Government.

Destroy this report when no longer needed by any method that will prevent disclosure of its contents or reconstruction of the document. Do not return to the originator.

REPORT DOCUMENTATION PAGE			Form Approved OMB No. 0704-01-0188	
The public reporting burden for this collection of information is estimated to average 1 hour per response, including the time for reviewing instructions, searching existing data sources, gathering and maintaining the data needed, and completing and reviewing the collection of information. Send comments regarding this burden estimate or any other aspect of this collection of information, including suggestions for reducing the burden to Department of Defense, Washington Headquarters Services Directorate for Information Operations and Reports (0704-0188), 1215 Jefferson Davis Highway, Suite 1204, Arlington, VA 22202-4302. Respondents should be aware that notwithstanding any other provision of law, no person shall be subject to any penalty for failing to comply with a collection of information if it does not display a currently valid OMB control number.				
PLEASE DO NOT RETURN YOUR FORM TO THE ABOVE ADDRESS.				
1. REPORT DATE (DD-MM-YYYY) February 2004		2. REPORT TYPE Final		3. DATES COVERED (From - To) January 1996 to January 2001
4. TITLE AND SUBTITLE  SPECIAL STUDY OF THE ENVIRONMENTAL EFFECTS ON STORAGE LIFE			5a. CONTRACT NUMBER	
			5b. GRANT NUMBER	
			5c. PROGRAM ELEMENT NUMBER	
6. AUTHORS  Brian T. Pope and Michael J. Cassiello			5d. PROJECT NUMBER	
			5e. TASK NUMBER	
			5f. WORK UNIT NUMBER	
7. PERFORMING ORGANIZATION NAME(S) AND ADDRESS(ES) ARDEC, QESA QE&SA Sciences (AMSRD-AAR-QES-B) Picatinny, NJ 07806-5000			8. PERFORMING ORGANIZATION REPORT NUMBER  AMSTA-AR-QAT-1-01	
9. SPONSORING/MONITORING AGENCY NAME(S) AND ADDRESS(ES) ARDEC, EM Technical Research Center (AMSRD-AAR-EMK) Picatinny, NJ 07806-5000			10. SPONSOR/MONITOR'S ACRONYM(S)	
			11. SPONSOR/MONITOR'S REPORT NUMBER(S) Technical Report ARQED-TR-03007	
12. DISTRIBUTION/AVAILABILITY STATEMENT  Approved for public release; distribution is unlimited.				
13. SUPPLEMENTARY NOTES				
14. ABSTRACT The goal of this report is to develop models that predict ammunition shelf life based on the storage facility, location, duration of storage, and previous stockpile exposure. To accomplish the goal, life models were developed based on historical data. Calculations based on ambient temperature, solar radiation, wind velocity, ammunition temperature, magazine and pallet dimensions, and magazine physical property data (e.g., density, specific heat) were used to determine insulation factors between the ambient environment and the ammunition. Once the insulation factors are determined, ammunition temperatures can be predicted solely on ambient temperatures, wind velocity, and solar radiation exposure. Initially, sine functions were developed to define ambient temperatures. These functions relate ambient temperatures to the time of year allowing engineers to more effectively predict temperatures the ammunition will experience. Using this information, shelf life forecasts can be calculated analytically.				
15. SUBJECT TERMS Stockpile      Storage life      Environmental effects      Munitions      Temperature      Modeling Magazine      Solar radiation      Relative humidity				
16. SECURITY CLASSIFICATION OF:			17. LIMITATION OF ABSTRACT	18. NUMBER OF PAGES
a. REPORT U	b. ABSTRACT U	c. THIS PAGE U	SAR	52
			19a. NAME OF RESPONSIBLE PERSON Michael Cassiello/Brian Pope	
			19b. TELEPHONE NUMBER (Include area code) (973) 724-5547	

## **ACKNOWLEDGMENT**

The authors wish to thank the Defense Ammunition Center and School (DACs) for all their help and support for this study. In particular, the authors are grateful to William Frerichs for providing the Storage Facilities Report. The authors would also like to recognize the enormous contribution provided by Jeffery A. Hart, Chad M. McKonly, and Mark Kotliar, whose help included the creation of all Pro/ENGINEER figures (figs. 5, 9, and 15), computer implementation, and overall report assimilation. Although the entire Predictive Engineering Group played a positive role in creating this study, particular gratitude must be paid to Kenneth C. Schenk, Dr. Eric R. Bixon, Abey Cherian, and John McEwan.

**THIS DOCUMENT CONTAINED  
BLANK PAGES THAT HAVE  
BEEN DELETED**

## CONTENTS

	Page
Introduction	1
Scope	1
Approach	1
Scientific Basis	1
Location Characterization	2
Daily Temperature Cycle	2
Yearly Temperature Cycle	4
Composite Yearly Temperature Cycle	5
Magazine Characterization	6
Physical and Dimensional Properties Example	6
Ambient Conditions	10
Ambient Temperature Model	10
Solar Radiation Model	12
Wind Convection Model	14
Heat Transfer	16
Heat Transfer Theory	16
Material Layer Heat Balances	17
Overall Heat Transfer Coefficients	17
Igloo Magazine Temperature at Different Locations	18
Predictive Engineering Methods	22
Arrhenius Equation	22
Life Consumed Concept	23
Summary	29
Bibliography	27
Appendices	
A Physical and Dimensional Property Values	29
B Actual (1 Jan 1996) Versus Model-generated (Day 1) Temperatures, Solar Radiations and Wind Velocities	33

C Model-generated (Day 1) Temperatures for Hawthorne Igloo Layers	37
D Derivation of Equation 17 from Equation 7	41
Distribution List	45

## FIGURES

	Page
1 Daily temperature cycle for Kuwait City	4
2 Yearly temperature cycle for Kuwait City	5
3 Composite yearly cycle for Kuwait City	6
4 Weather station position on top of igloo	7
5 Igloo magazine (60 ft 8 in. L × 26 ft 6 in. W × 12 ft 9 in. H)	8
6 View of 155-mm projectile pallets within igloo	8
7 Storage packing in igloo magazine	9
8 Instrumentation positioning	9
9 Igloo heat transfer layers	10
10 Ambient temperature versus Julian date	11
11 Solar radiation versus Julian date	13
12 Solar radiation versus Julian date (section of fig. 11)	13
13 Wind speed (mph) versus Julian date	15
14 Actual temperature versus Julian date	20
15 Igloo heat transfer layers (Julian day 305, hour 21)	21
16 Pallet temperature (actual versus model) versus Julian date	21
17 Temperature difference histogram	22
18 Life consumed versus exposure time	25
19 Life consumed in 1 yr	25

## INTRODUCTION

The shelf life of ammunition is affected primarily by temperature, relative humidity, and solar radiation. Temperature control is essential for maintaining ammunition serviceability. Characterizing storage facilities to optimize magazine usage and design can be accomplished by maximizing insulation and proper airflow, thereby improving temperature control. Equation based modeling will allow storage facilities to be quantitatively characterized and thereby optimized for maintaining high quality ammunition and extending shelf life.

### Scope

This study will:

- Quantify the adverse environmental effects on ammunition in storage
- Derive engineering equations to determine the temperature conditions that ammunition is exposed to within storage magazines
- Develop life prediction models to forecast ammunition shelf life

Objectives:

- Develop environmental equations that delineate inside storage temperature at various geographic locations as a function of diurnal ambient temperature, wind velocity, and solar radiation
- Demonstrate, by example, the integration of the developed environmental equations with existing life prediction models to forecast shelf life

### Approach

The goal is to develop models that predict ammunition shelf life based on the storage facility, location, duration of storage, and previous stockpile exposure. To accomplish the goal, life models were developed based on historical data. Calculations based on ambient temperature, solar radiation, wind velocity, ammunition temperature, magazine and pallet dimensions, and magazine physical property data (e.g., density, specific heat) were used to determine insulation factors between the ambient environment and the ammunition. Once the insulation factors are determined, ammunition temperatures can be predicted solely on ambient temperatures, wind velocity, and solar radiation exposure. Initially, sine functions were developed to define ambient temperatures. These functions relate ambient temperatures to the time of year allowing engineers to more effectively predict temperatures the ammunition will experience. Using this information, shelf life forecasts can be calculated analytically.

### Scientific Basis

The travel of thermal energy through materials is best understood by the laws of heat transfer. The study of heat transfer differs from thermodynamic studies, in that; it focuses on the rate of energy transmission, whereas thermodynamics is the basic science that deals with energy, matter, and their interactions.

The following heat transfer concepts were considered:

- Heat transfer is based on temperature gradients within two or more bodies
- Heat energy flows from a high temperature region to a low temperature region until equilibrium is achieved

To predict temperatures in an ammunition storage facility using the approaches discussed in this study, the following data must be available:

- Ambient temperature, wind velocity, and solar radiation data for a given location
- Magazine dimensions and pallet locations
- Physical property parameters (e.g., specific heat, geometry, and density) of magazine makeup and its contents

The temperature of ammunition (even if stored in a magazine) is affected by solar radiation. The energy coming from the sun, solar energy, reaches the earth in the form of electromagnetic waves. Upon impact with a material's surface, solar radiation will raise the temperature of the material above the ambient temperature to a higher radiation-induced temperature.

## LOCATION CHARACTERIZATION

The first major step towards classifying a magazine storage system was to quantify the environment at a specific magazine location. The quantification was accomplished by developing models that express the ambient temperature as a function of the Julian<sup>1</sup> time. Temperatures on an hourly basis were desired in order to develop a true equilibrium relationship between environmental and ammunition storage temperatures for a given geographic location. To account for seasonal and daily temperature changes in the environment, trigonometric models were developed. These models lend themselves to better integration with predictive models and allow consolidation of data into summary values for ease of computer storage.

Even though both metric and English units are used throughout this study, all calculations were accomplished in metric units.

### Daily Temperature Cycle

The daily temperature cycle model, equation 1, was developed as a general equation for any location. The values that are entered into the model are used to develop the precise equation for a specific location. The cycle begins at Julian hour 1 (1 A.M.) and ends at Julian hour 24 (12 A.M., midnight). However, since it is a trigonometric (sine wave) model, the cycle repeats itself. Therefore, the temperature modeled for the 25th hour is equivalent to that of the 1st hour.

<sup>1</sup>The Julian calendar is used as the standard for overall consistency. Day 1 is equivalent to January 1<sup>st</sup>, Day 32 is February 1<sup>st</sup>, and leap year is neglected in this study. Julian hour refers to military time, where Julian hour 1 is equivalent to 0100 hrs.

$$T(HOUR) = T_{AVE_{HOUR}} + \frac{RG_{HOUR}}{2} \sin \left[ \frac{2\pi(x_{HOUR} + ALIGN_{HOUR})}{n_{HOUR}} \right] \quad (1)$$

where

- $T(HOUR)$  is the environmental temperature as a function of Julian hour
- $T_{AVE}$  is the average temperature for a given location
- $RG$  is the maximum minus minimum temperature range for a given location
- $x$  is the Julian hour (1 to 24)
- $ALIGN$  is the horizontal centering adjustment to Julian calendar base on geographic location (note)
- $n$  is the number of data points (24 for hourly data, 365 for daily data)
- $HOUR$  all variables with this subscript are "as a function of hours"

**Note:** The value for  $ALIGN$  is determined by minimizing the absolute  $ERROR$  between the actual temperature and the model-derived temperature where

$$ERROR = \max |T_{ACT} - T_{MODEL}|$$

Since  $T_{MODEL}$  is a function of the value for  $ALIGN$ , each  $ALIGN$  value will correspond to one  $ERROR$  value. Therefore, we vary the value for  $ALIGN$  until we achieve the minimum  $ERROR$  value. ( $ALIGN_{HOUR}$  will be between 0 and 24, and  $ALIGN_{DAY}$  will be between 0 and 365.) The  $ALIGN$  value with the minimum  $ERROR$  value is inserted into the  $T_{MODEL}$  equation (as a constant) to characterize a particular data set.

As an example, the daily temperature cycle for Kuwait City was modeled using equation 1. Published historical data for the hourly temperatures for Kuwait City were the basis of example equation 1A, which is the precise equation for this example

$$T(HOUR) = 98.4 + \frac{24}{2} \sin \left[ \frac{2\pi(x_{1-24} + 15)}{24} \right] \quad (1A)$$

Figure 1 depicts the accuracy of the model, by plotting the actual hourly temperatures and the modeled daily temperature cycle for Kuwait City. Although the model does not exactly correlate to the actual data points, the  $T(HOUR)$  graphed line and actual temperature data are always within 3°F. It should be noted that the highest temperatures for the Kuwait City cycle are during midday between 1400 and 1600 hrs (2 to 4 P.M.).

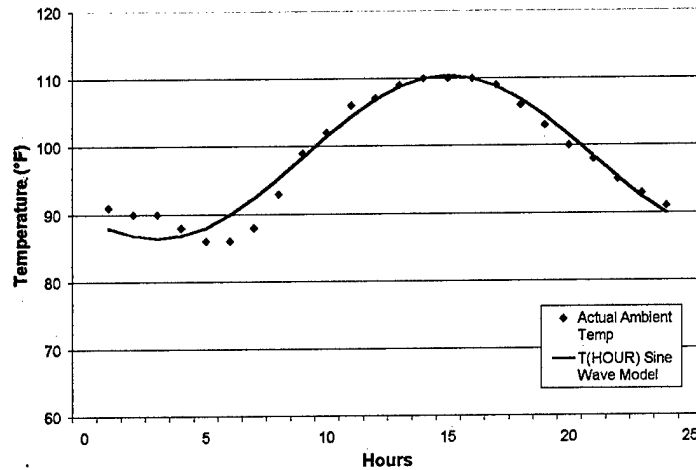

Figure 1  
Hourly temperature cycle for Kuwait City

### Yearly Temperature Cycle

The next step is to develop a model for the yearly or (day to day) temperature cycle for a specific geographic location. To maintain consistency, this model is also a function of the Julian date. Equation 2 is a modification of the  $T(HOUR)$  model, with hourly temperatures replaced by daily temperatures. In this case, the temperature for each day is modeled and the cycle consists of 365 days as opposed to 24 hrs. Day 1 is January 1st and day 365 is December 31st. This model also repeats itself, but instead of repeating from day to day, it repeats from year to year. Therefore, day 366 has the equivalent temperature as day 1.

$$T(DAY) = T_{AVE_{DAY}} + \frac{RG_{DAY}}{2} \sin \left[ \frac{2\pi (y_{DAY} + ALIGN_{DAY})}{n_{DAY}} \right] \quad (2)$$

where

$T(DAY)$  is the environmental temperature as a function of Julian day

$y$  is the Julian day (1 to 365)

$DAY$  all variables with this subscript are "as a function of days"

As an example, the same location (Kuwait City) was used to create a precise yearly temperature cycle. In this model, it was apparent that the highest temperatures occur in the summer months, whereas, for the daily cycle the highest temperatures occurred during midday (as expected). Published historical data for the temperature in Kuwait City was also used to generate example equation 2A for the yearly cycle.

$$T(DAY) = 98 + \frac{40}{2} \sin \left[ \frac{2\pi (y_{1-365} + 228)}{365} \right] \quad (2A)$$

Figure 2 shows the yearly environmental temperature cycle for Kuwait City. Actual data is not depicted for clarity. The hottest days are between Julian date 200 (June 19th) and 250 (September 7th).

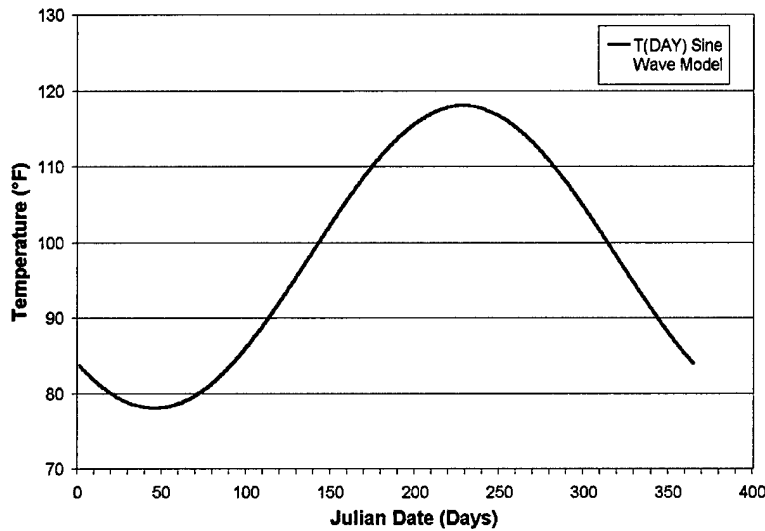

Figure 2  
Daily temperature cycle for Kuwait City

### Composite Yearly Temperature Cycle

A temperature model now exists for every hour within a day (equation 1) and for every day within a year (equation 2). By combining equations 1 and 2, a location can be temperature 'characterized' on an hourly basis for an entire year. The combined daily and yearly temperature cycles result in equation 3, in which the  $T(DAY)$  model replaces the average hourly temperature ( $T_{AVE_{HOUR}}$ ) in the  $T(HOUR)$  model.

$$T(DAY, HOUR) = T(DAY) + \frac{RG_{HOUR}}{2} \sin \left[ \frac{2\pi (X_{HOUR} + ALIGN_{HOUR})}{n_{HOUR}} \right] \quad (3)$$

where

$T(DAY, HOUR)$  is the environmental temperature as a function of Julian day and hour.

Continuing with the Kuwait City example, an overall yearly temperature cycle was created. In this example, the diurnal temperature variation (hourly during a day) is integrated with the annual temperature variation (daily during a year) to provide a complete cycle that accounts for each and every hour for a year. The combined cycles create one large sine wave from Julian Day 1 to Day 365. Inside this large sine wave, there are 364 small sine waves between each and every Julian day. The overall model runs for the entire year and repeats from year to year. The following precise example, equation 3A, for Kuwait City results in 8,760 ( $24 \times 365$ ) data points, accounting for every hour within a year.

$$T(DAY, HOUR) = 98.0 + \frac{40}{2} \sin \left[ \frac{2\pi (y_{1-365} + 228)}{365} \right] + \frac{24}{2} \left[ \frac{2\pi (x_{1-24} + 15)}{24} \right] \quad (3A)$$

Figure 3 depicts an interval (from Julian date 180 to 230) of the example equation 3A plot for the combined model.

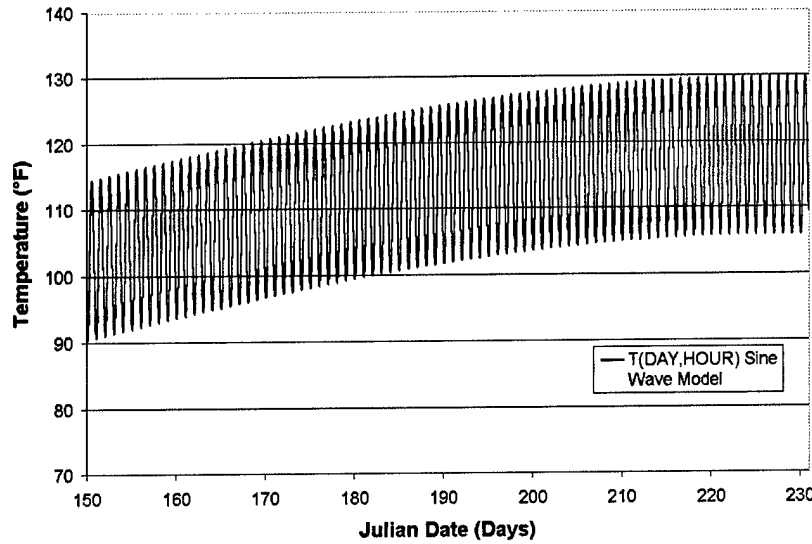

Figure 3  
Daily temperature cycle for Kuwait City

## MAGAZINE CHARACTERIZATION

The second major step towards classifying a magazine storage system was to quantify the magazine itself, which is accomplished through model development of the physical and dimensional properties of the magazine. These properties are used to determine the insulation factors for a magazine, which are in turn used to determine the temperatures at key locations within the magazine. The remainder of this study will be based on the igloo magazine discussed in this section, which is located in Hawthorne, Nevada.

### Physical and Dimensional Properties Example

An igloo magazine was used as an example for 'Magazine Characterization.' Dimensional properties were obtained from the Industrial Operations Command (IOC), 1994, Storage Facilities report. The physical properties were obtained from chemical handbooks for the materials that make up the igloo magazine wall, the earth that covers the igloo, the air between the wall and the ammunition pallets, and the ammunition pallets. Physical and dimensional property values are summarized in appendix A.

Figure 4<sup>2</sup> is a photograph of the Hawthorne earth-covered igloo magazine that will be used as an example for the remainder of this study. This figure also shows the exterior weather station, which measured ambient temperature, wind velocity, and solar radiation.

The igloo magazine dimensions are depicted in figure 5. The specifying dimensions are 60 ft 8 in. L × 26 ft 6 in. W × 12 ft 9 in. H igloo magazine, where H refers to the highest point of an arched roof.

Figure 6<sup>2</sup> is a photograph of the interior of the earth-covered igloo magazine, which shows the ammunition pallet stacking and the temperature instrumentation.

Figure 7<sup>2</sup> shows a computerized isometric view of the pallet stacking procedure.

Figure 8<sup>2</sup> depicts the exact temperature instrumentation locations within the igloo magazine.

Figure 9 is a Pro/ENGINEER schematic, which shows the heat transfer layers within the igloo magazine. The bar on the left is a blow-up of a very narrow center column of the igloo. Models were generated to determine a temperature at the top of each layer for the center column.



Figure 4  
Weather station positioned on top of igloo

<sup>2</sup>Figures 4 and 6 through 8 were obtained from the Defense Ammunition Center website ([www.dac.army.mil](http://www.dac.army.mil)).

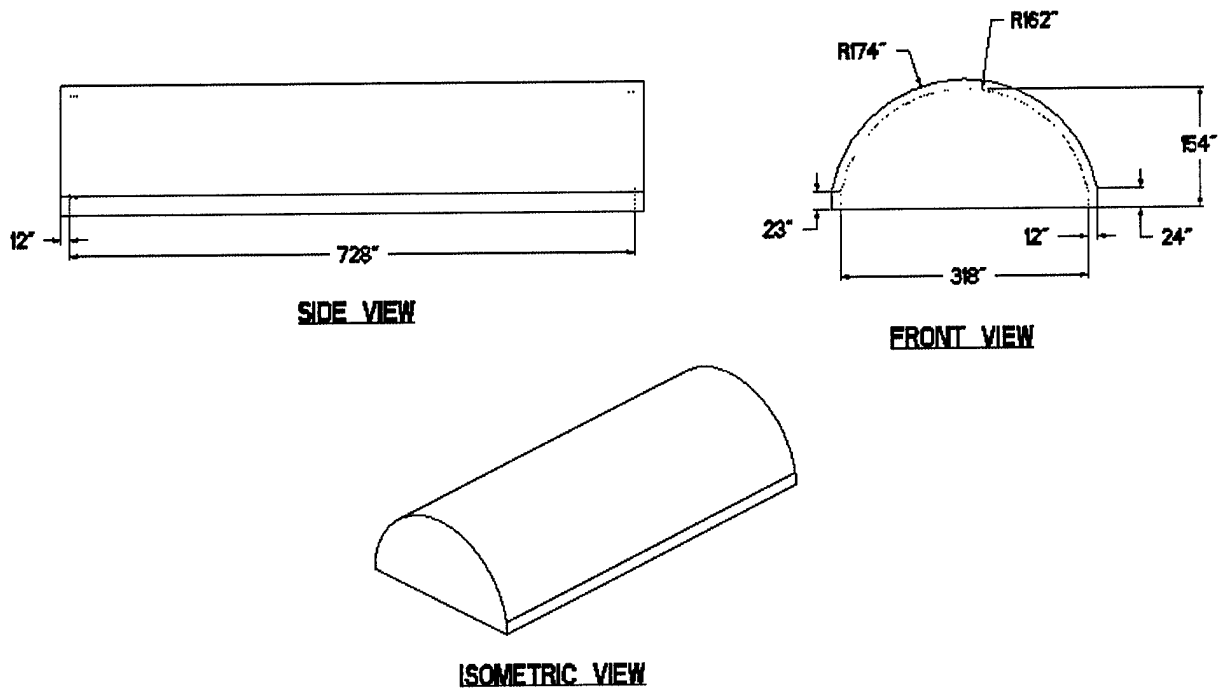

Figure 5  
 Igloo magazine (60 ft 8 in. L × 26 ft 6 in. W × 12 ft 9 in. H)

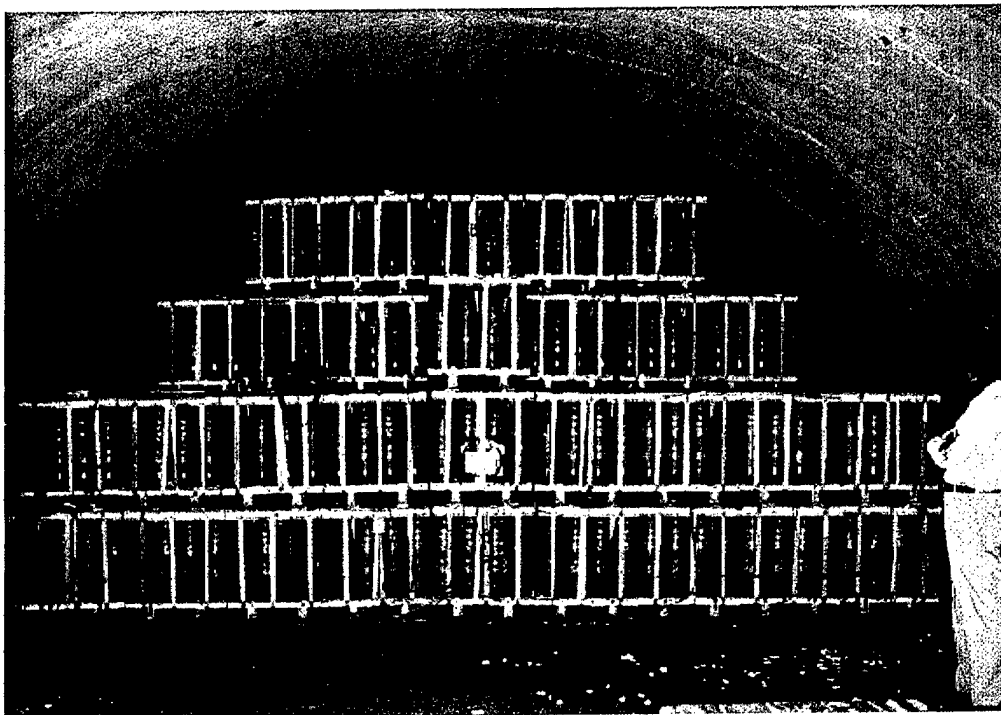

Figure 6  
 View of 155-mm projectile pallets within igloo

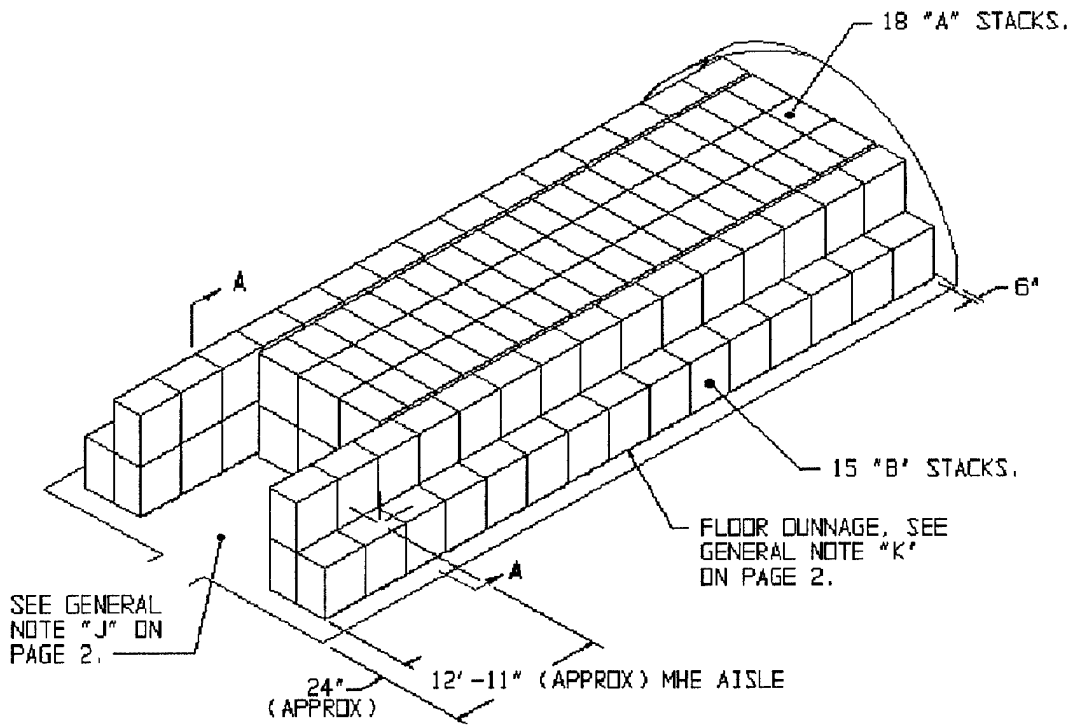

Figure 7  
Storage packing in igloo magazine

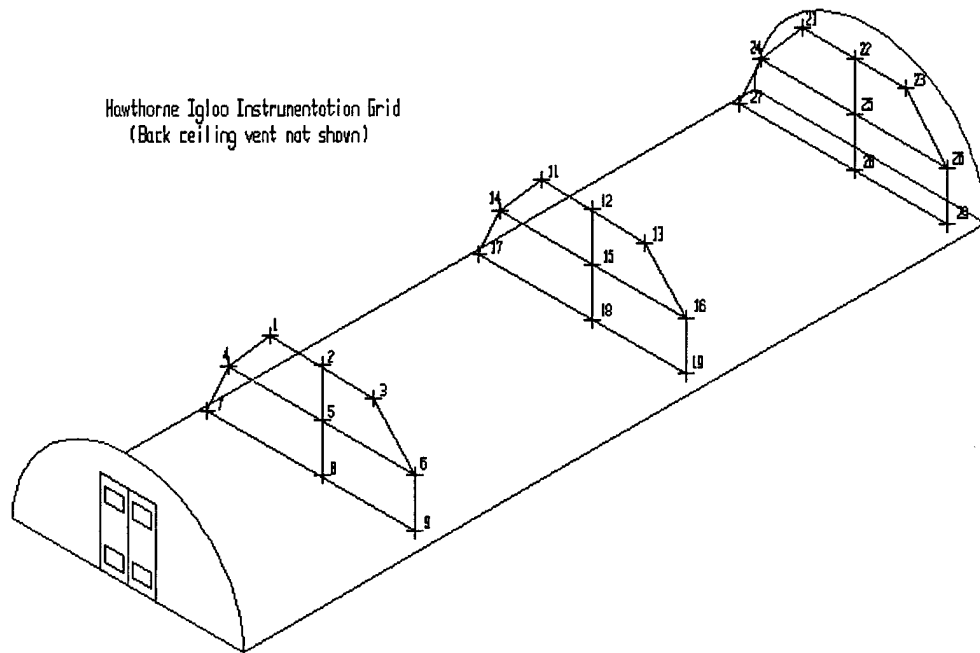

Figure 8  
Instrumentation positioning

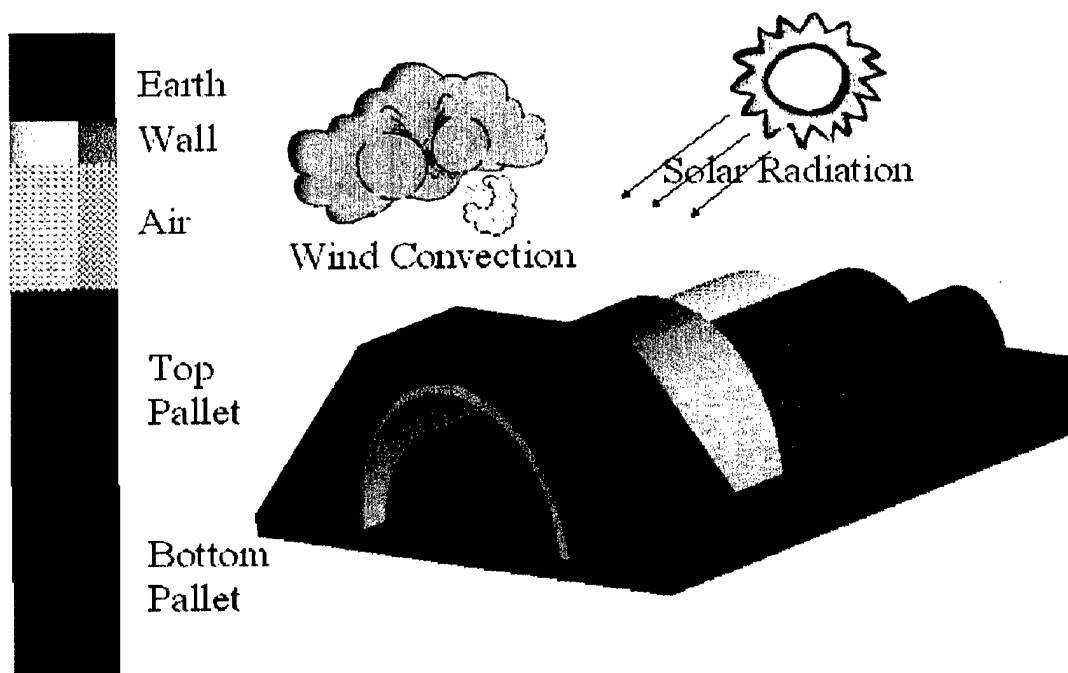

Figure 9  
Igloo heat transfer layers

### AMBIENT CONDITIONS

The ambient conditions experienced by an ammunition storage magazine include the effects of solar radiation and wind velocity in addition to the ambient temperature. Thankfully, this type of data was obtained for many ammunition storage locations throughout the world every half-hour for entire years. This data can be very useful for engineers to assess the storage conditions that the ammunition is facing and its apparent shelf life. However, the number of data measurements for 1 yr alone is over 17,000 for each effect. This number of data points can be very unwieldy for computer storage even for today's technology. The models below were developed to eliminate the need for large databases by consolidating the data into equation form. The models for ambient temperature, solar radiation, and wind velocity are intended to be general for all locations; although, precise models for Hawthorne are also provided in the subsequent sections. Actual (Jan 1, 1996) versus model-generated (Day 1) temperatures, solar radiations, and wind velocities are given in appendix B.

#### Ambient Temperature Model

The yearly composite equation (equation 4) and precise model (example equation 4A) for the ambient temperature ( $T_{AMB}$ ) experienced by the Hawthorne igloo magazine are

$$T_{AMB} = T_{AVE} + \frac{RG_{DAY}}{2} \sin \left[ \frac{2\pi(y + ALIGN_{DAY})}{n_{DAY}} \right] + \frac{RG_{HOURLY}}{2} \sin \left[ \frac{2\pi(x + ALIGN_{HOURLY})}{n_{HOURLY}} \right] \quad (4)$$

where

- $T_{AMB}$  is the ambient temperature as experienced in Hawthorne
- $T_{AVE}$  is the average daily temperature in Hawthorne
- $RG$  is the maximum minus minimum temperature range for Hawthorne
- $ALIGN$  is the horizontal centering adjustment to Julian calendar for Hawthorne
- $n$  is the number of data points (24 for hourly data, 365 for daily data)
- $HOUR$  all variables with this subscript are "as a function of hours"
- $DAY$  all variables with this subscript are "as a function of days"
- $x$  is the Julian hour (1 to 24)
- $y$  is the Julian day (1 to 365)

$$T_{AMB} = 55.7923 + 17.1175 \sin \left[ \frac{2\pi(y+270)}{58.0916} \right] + 11.4450 \sin \left[ \frac{2\pi(x+14)}{3.8197} \right] \quad (4A)$$

Figure 10 graphically depicts example equation 4A for an entire year.

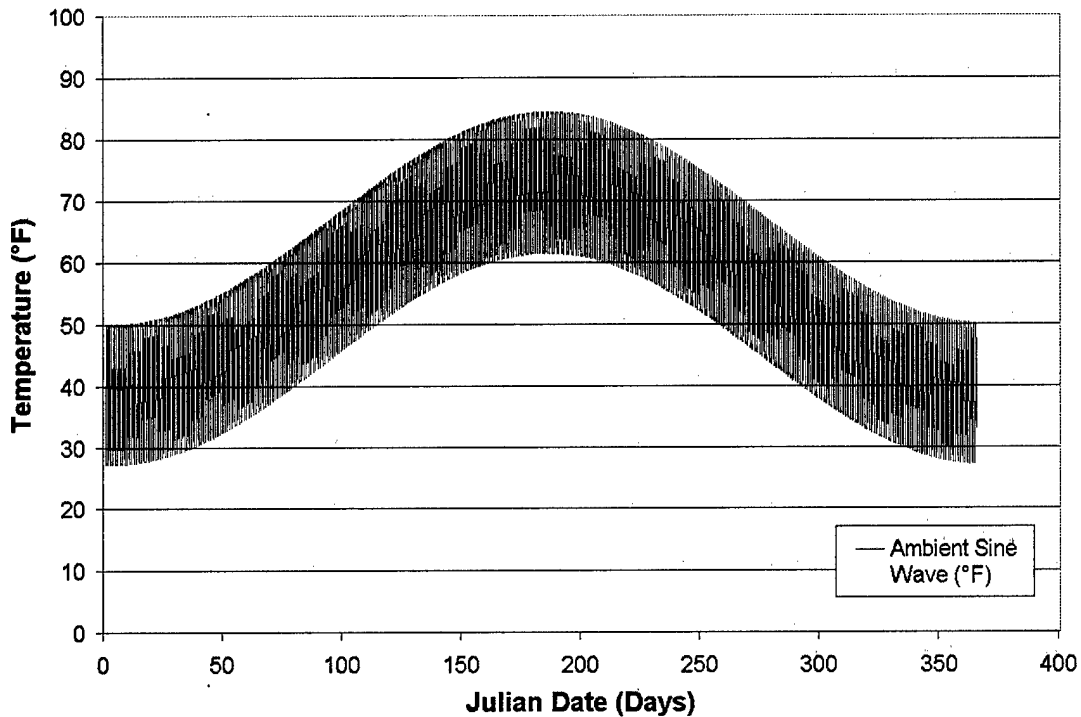

Figure 10  
Ambient temperature versus Julian date

## Solar Radiation Model

Heat transfer from the ambient environment to the earth that covers the igloo magazine is exposed to solar radiation and wind convection. Solar radiation values were recorded, and a solar radiation sine wave model (equation 5) was established as

$$SR_{AMB} = |SR_{DAY}| + SR_{DAY} + RG_{DAY} (|SR_{HOURLY}| + SR_{HOURLY} + LOCATE) \quad (5)$$

where

$SR_{AMB}$  is the solar radiation model experienced by Hawthorne

$SR_{DAY} = \sin \left[ \frac{2\pi(y + ALIGN_{DAY})}{4n_{DAY}} \right]$ , is the solar radiation as a function of days

$SR_{HOURLY} = \sin \left[ \frac{2\pi(x + ALIGN_{HOURLY})}{4n_{HOURLY}} \right]$ , is the solar radiation as a function of hours

$x$  is the Julian hour (1 to 24)

$y$  is the Julian day (1 to 365)

$ALIGN$  is the horizontal centering adjustment to Julian calendar for Hawthorne

$LOCATE$  is the vertical centering adjustment to Julian calendar

The precise model (example equation 5A) for the solar radiation model ( $SR_{AMB}$ ) experienced by the Hawthorne igloo magazine is

$$SR_{AMB} = \left| \sin \left( \frac{y + 200}{232.3664} \right) \right| + \sin \left( \frac{y + 200}{232.3664} \right) + 0.5596 \left[ \left| \sin \left( \frac{x + 18}{3.8197} \right) \right| + \sin \left( \frac{x + 18}{3.8197} \right) - 2.1 \right] \quad (5A)$$

**Note:** The solar radiation ( $SR_{AMB}$ ) sine wave was modified to provide positive values only. The following algorithm was entered into the equation model in order to negate nonexistent negative solar radiation values.

$$IF(SR_{AMB} < 0, SR_{AMB} = 0); ELSE(SR_{AMB} = SR_{AMB})$$

Figure 11 shows both the actual and modeled solar radiation data.

Figure 12 is a blown-up section of figure 11, which is intended to show the detailed daily curves.

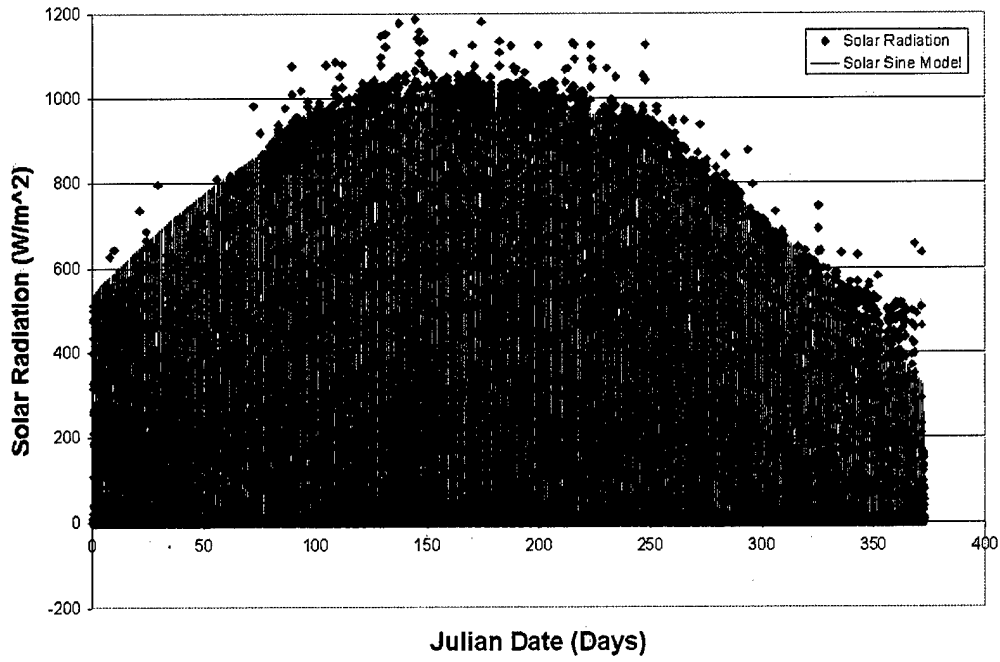

Figure 11  
Solar radiation versus Julian date

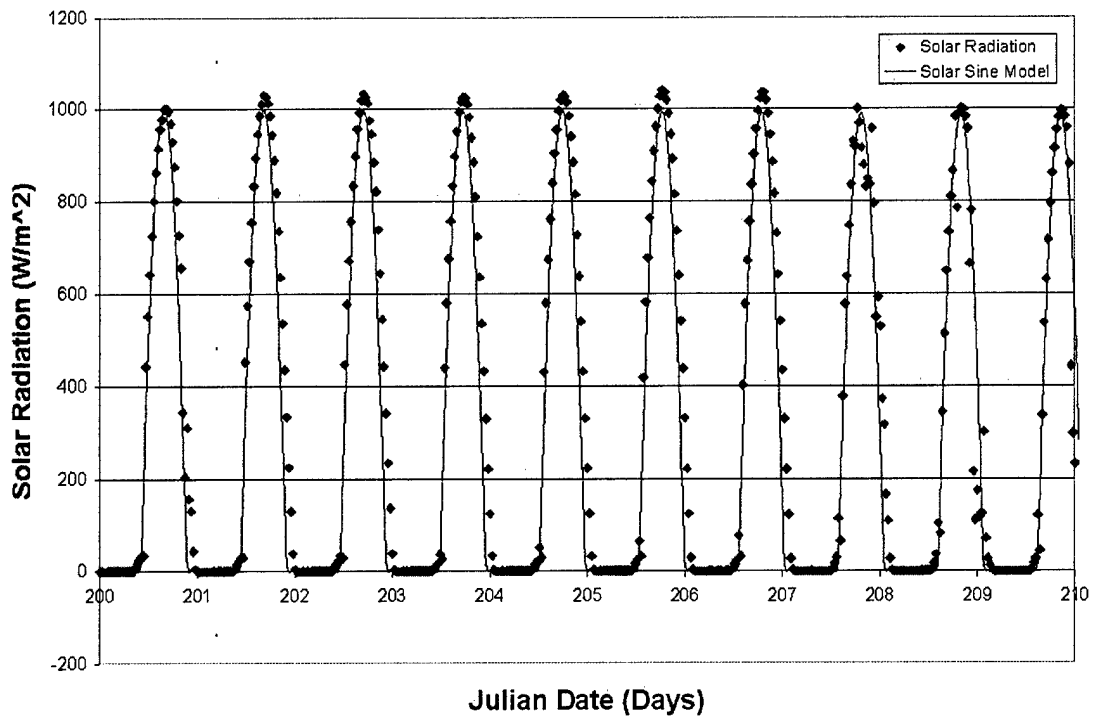

Figure 12  
Solar radiation versus Julian date (section of fig. 11)

## Wind Convection Model

Wind velocity values were also recorded, and a wind velocity ( $WV_{AMB}$ ) sine wave model (eq 6) was established as

$$WV_{AMB} = RG + \frac{RG_{DAY}}{2} \sin \left[ \frac{2\pi (x_{HOUR} + ALIGN_{HOUR})}{n_{HOUR}} \right] \quad (6)$$

where

- $WV_{AMB}$  is the wind velocity model experienced by Hawthorne
- $RG$  is the maximum minus minimum wind velocity range for Hawthorne
- $ALIGN$  is the horizontal centering adjustment to Julian calendar for Hawthorne
- $HOUR$  all variables with this subscript are "as a function of hours"
- $DAY$  all variables with this subscript are "as a function of days"
- $n$  is the number of data points (24 for hourly data)
- $x$  is the Julian hour (1 to 24)

The precise wind velocity ( $WV_{AMB}$ ) model (example equation 6A) experienced by the Hawthorne igloo magazine is

$$WV_{AMB} = 8.8060 + 8.1825 \sin \left( \frac{x + 14}{3.8197} \right) \quad (6A)$$

Figure 13 shows both the actual and modeled wind velocity data.

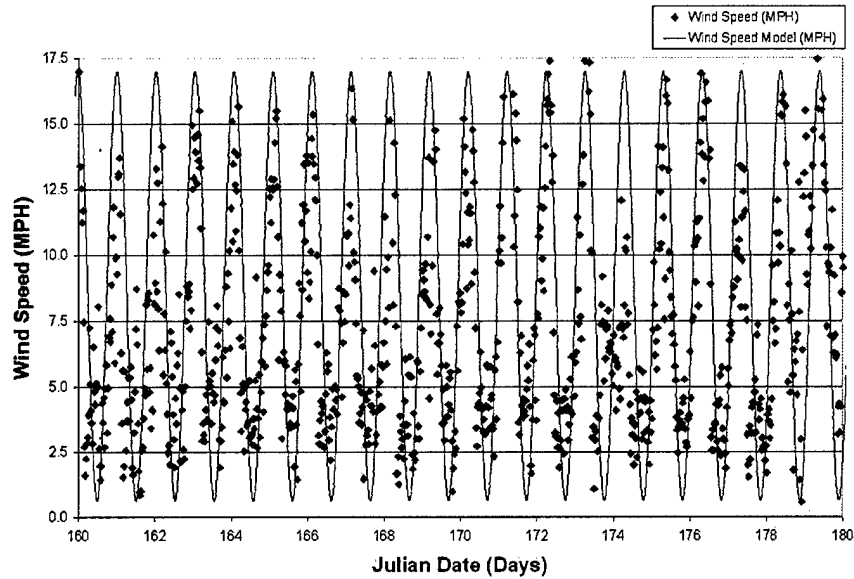

Figure 13  
Wind speed (mph) versus Julian date

The wind velocity model was used to determine the coefficient of heat transfer at ambient conditions ( $h_{AMB}$ ). Table 1 provides the sample calculations for air properties at both 300 K and 250 K. Even though  $h_{AMB}$  can be considered a function of temperature, for air it only varies slightly as shown by the following example. As a result, subsequent calculations will use the physical property constants of air at 300 K.

Table 1  
Coefficient of heat transfer (convection) as a function of wind velocity

Physical properties of air at 300 K (80°F)	Physical properties of air at 250 K (-10°F)
$v = 1.59 \times 10^{-5} \text{ m}^2/\text{s}$	$v = 1.14 \times 10^{-5} \text{ m}^2/\text{s}$
$k = 2.63 \times 10^{-2} \text{ W}/(\text{m}\cdot\text{K})$	$k = 2.23 \times 10^{-2} \text{ W}/(\text{m}\cdot\text{K})$
$Pr = 0.707$	$Pr = 0.72$
where $v$ = kinematic velocity $k$ = thermal conductivity $Pr$ = Prandtl number	
Wind velocity $v = 1.8 \text{ m/s}$ (4 mph)	Wind velocity $v = 1.8 \text{ m/s}$ (4 mph)
Surface depth $L = 0.6096 \text{ m}$ (2 ft)	Surface depth $L = 0.6096 \text{ m}$ (2 ft)
Reynolds number (must be less than $5 \times 10^5 v \cdot L/v$ ) $Re = 6.91 \times 10^4$	Reynolds number (must be less than $5 \times 10^5 v \cdot L/v$ ) $Re = 6.59 \times 10^4$
Nuselt number ( $Nu = 0.332 \cdot Re^{0.5} \cdot Pr^{0.333}$ ) $Nu = 77.7$	Nuselt number ( $Nu = 0.332 \cdot Re^{0.5} \cdot Pr^{0.333}$ ) $Nu = 77.7$
Convection coefficient ( $h_{AMB} = Nu \cdot k/L$ ) $h_{AMB} = 3.36 \text{ W}/(\text{m}^2 \cdot \text{K})$	Convection coefficient ( $h_{AMB} = Nu \cdot k/L$ ) $h_{AMB} = 3.36 \text{ W}/(\text{m}^2 \cdot \text{K})$

## HEAT TRANSFER

The following will use the sine models previously developed for the ambient conditions to calculate internal magazine temperatures. The heat transfer theory outlines the procedure by which the integrated relationships are obtained. The derivation is based on the theories discussed in the publication, Heat Transmission by William H. McAdams (McGraw Hill, 1964). The heat transfer approach is employed for all material layers with a modification used for the heat transfer between ambient conditions and the earth layer of the igloo magazine to account for solar radiation and wind velocity effects.

### Heat Transfer Theory

A simple case of unsteady heat transfer is discussed. Consider a material layer of volume  $V$ , surface area  $A$ , and thickness  $L$  at unknown temperature  $T$  in contact with another material layer at temperature  $T_2$ . At any time  $t$ , the quantity of heat,  $dQ$ , transferred in the short time,  $dt$ , depends upon the surface area of the first material layer, the difference in temperature between the two layers ( $T_2 - T$ ), and the coefficient of heat transfer between the two layers ( $h$ ). Therefore, by determining a heat balance on the first layer, with a density  $\rho$  and specific heat  $c$  yields:

$$\text{Step 1: } dQ = h \cdot A(T_2 - T)dt = V \cdot \rho \cdot c \cdot dT$$

Assuming  $h$ ,  $A$ ,  $V$ ,  $\rho$ , and  $c$  are constant, define  $U$  (the overall heat transfer coefficient):

$$\text{Step 2: } U = \frac{hA}{V\rho c}$$

Substitute step 2 into step 1 and rearrange:

$$\text{Step 3: } Udt = \frac{1}{(T_2 - T)}dT$$

Integrate from  $t = 0$  to  $t = t'$  and  $T = T_1$  to  $T = T_1'$

$$\text{Step 4: } \int_0^{t'} Udt = \int_{T_1}^{T_1'} \frac{1}{(T_2 - T)}dT$$

Integration yields:

$$\text{Step 5: } Ut' = \ln \frac{T_2 - T_1}{T_2 - T_1'}$$

Solving for  $T_1'$  gives:

$$\text{Step 6: } T_1' = T_2 - \frac{T_2 - T_1}{e^{Ut'}}$$

Where  $T_1'$  is the surface temperature of the first material layer at time  $t'$ .

## Material Layer Heat Balances

The heat balance (equations 7 to 11) is the starting equation in the determination of interior magazine temperatures. Balances were performed around the outer surface of the earth, wall, interior air, outer pallet, and inner pallet layers. The equation for heat transfer between ambient conditions and the earth layer has an additional expression ( $\alpha_E A_{AMB} SR_{AMB}$ ) to account for solar radiation effects. All other material layer derivations are based on the heat transfer theory.

$$dQ_{AMB \rightarrow E} = [h_{AMB} A_{AMB} (T_{AMB} - T_E) + \alpha_E A_{AMB} SR_{AMB}] dt = V_{AMB} \rho_{AMB} c_{AMB} dT \quad (7)$$

$$dQ_{E \rightarrow W} = h_E A_E (T_E - T_W) dt = V_E \rho_E c_E dT \quad (8)$$

$$dQ_{W \rightarrow A} = h_W A_W (T_W - T_A) dt = V_W \rho_W c_W dT \quad (9)$$

$$dQ_{A \rightarrow O} = h_A A_A (T_A - T_O) dt = V_A \rho_A c_A dT \quad (10)$$

$$dQ_{O \rightarrow I} = h_O A_O (T_O - T_I) dt = V_O \rho_O c_O dT \quad (11)$$

where

$x$  is the subscript referring to material layer:

- $x = AMB$  for ambient conditions
- $x = E$  for earth
- $x = W$  for wall
- $x = A$  for air (inside the igloo magazine)
- $x = O$  for the outer pallet layer
- $x = I$  for the inner pallet layer

- $h_x$  is the coefficient of heat transfer of material layer  $x$  [ $W/(m^2 \cdot K)$ ]
- $A_x$  is the area of material layer  $x$  through which heat flows at right angles ( $m^2$ )
- $\alpha_x$  is the solar absorptivity of the earth layer (unitless)
- $V_x$  is the volume of material layer  $x$  ( $m^3$ )
- $\rho_x$  is the density of material layer  $x$  ( $kg/m^3$ )
- $c_x$  is the heat capacity of material layer  $x$  [ $J/(kg \cdot K)$ ]

## Overall Heat Transfer Coefficients

Once the properties and dimensions are ascertained, the overall heat transfer coefficients ( $U$ ) can be calculated (eqs 12 to 16) for each heat transfer layer. Note that for solid layers the coefficient of heat transfer ( $h$ ) is equal to the material heat conductivity ( $k$ ) divided by the thickness of the layer ( $L$ ),  $h = k/L$ .

$$U_{AMB} = \frac{h_{AMB} A_{AMB}}{V_{AMB} \rho_{AMB} c_{AMB}} \quad (12)$$

$$U_E = \frac{k_E A_E}{L_E V_E \rho_E c_E} \quad (13)$$

$$U_W = \frac{k_W A_W}{L_W V_W \rho_W c_W} \quad (14)$$

$$U_A = \frac{k_A A_A}{L_A V_A \rho_A c_A} \quad (15)$$

$$U_O = \frac{k_O A_O}{L_O V_O \rho_O c_O} \quad (16)$$

where

$U_x$  is the overall heat transfer coefficient of material layer  $x$  ( $\text{sec}^{-1}$ ) (table 2)

$k_x$  is the thermal conductivity of material layer  $x$  [ $\text{W}/(\text{m}\cdot\text{K})$ ]

$L_x$  is the thickness of material layer  $x$  (m)

Physical and dimensional property values are in appendix A. By substituting values into equations 12 through 16, the overall heat transfer coefficients are determined for the igloo magazine.

Table 2  
Overall heat transfer coefficients for the material layers

$U_{AMB} = f(h_{AMB}) = 1.85 \times 10^{-3} \text{ to } 9.67 \times 10^{-3} \text{ sec}^{-1}$
$U_E = 3.65 \times 10^{-7} \text{ sec}^{-1}$
$U_W = 1.87 \times 10^{-6} \text{ sec}^{-1}$
$U_A = 1.12 \times 10^{-3} \text{ sec}^{-1}$
$U_O = 1.67 \times 10^{-4} \text{ sec}^{-1}$

### Igloo Magazine Temperature at Different Locations

The overall heat transfer coefficients ( $U$ ) allow the calculation of the heat transfer through each material layer, enabling the calculation of temperatures at various locations inside the magazine as a function of the ambient temperature, solar radiation, and wind speed. Values for Julian day 1 are listed in appendix B. The temperatures were calculated using equations 17 through 21, which represent the culmination of the preceding heat transfer derivations. Model-generated temperatures at half-hour intervals for Julian day 1 for the five locations are provided in appendix C.

By integrating equations 7 through 11 depicted in Material Layer Heat Balances, equations 17 through 21 are derived. The derivation of equation 17 is shown in appendix D.

where

$x$  is the subscript referring to material layer:

$x = AMB$  for ambient conditions

$x = E$  for earth

$x = W$  for wall

$x = A$  for air (inside the igloo magazine)

$x = O$  for the outer pallet layer

$x = I$  for the inner pallet layer

$T'_x$  is the temperature of material layer  $x$  at time  $t'$  ( $^{\circ}F$ )

$T_x$  is the temperature of material layer  $x$  at time = 0 ( $^{\circ}F$ )

$U_x$  is the overall heat transfer coefficient of material layer  $x$  ( $sec^{-1}$ )

$t'$  is the selected time of temperature calculation (sec)

$$T'_E = T_E e^{-U_{AMB}t'} + \left( T_{AMB} + \frac{\alpha_E SR_{AMB}}{h_{AMB}} \right) (1 - e^{-U_{AMB}t'}) \quad (17)$$

where

$T'_E$  is the outer surface temperature of earth layer at time  $t'$  ( $^{\circ}F$ )

$T_E$  is the outer surface temperature of earth layer at time = 0 ( $^{\circ}F$ )

$T_{AMB}$  is the ambient temperature at time = 0 ( $^{\circ}F$ )

$\alpha_E$  is the solar absorptivity of the earth layer = 0.10 (unitless)

$SR_{AMB}$  is the observed solar radiation ( $W/m^2$ )

$$T'_W = T_E - \frac{T'_E - T_W}{e^{U_E t'}} \quad (18)$$

where

$T'_W$  is the outer surface temperature of wall layer at time  $t'$  ( $^{\circ}F$ )

$T_W$  is the outer surface temperature of wall layer at time = 0 ( $^{\circ}F$ )

$$T'_A = T_W - \frac{T'_W - T_A}{e^{U_W t'}} \quad (19)$$

where

$T'_A$  is the outer surface temperature of air layer at time  $t'$  (°F)

$T_A$  is the outer surface temperature of air layer at time = 0 (°F)

$$T'_O = T_A - \frac{T'_A - T_O}{e^{U_A t'}} \quad (20)$$

where

$T'_O$  is the outer surface temperature of outer pallet layer at time  $t'$  (°F)

$T_O$  is the outer surface temperature of outer pallet layer at time = 0 (°F)

$$T'_I = T_O - \frac{T'_O - T_I}{e^{U_O t'}} \quad (21)$$

where

$T'_I$  is the outer surface temperature of inner pallet layer at time  $t'$  (°F)

$T_I$  is the outer surface temperature of inner pallet layer at time = 0 (°F)

The measured temperature data at external, earth-covered, and internal (middle pallet) locations for the Hawthorne igloo magazine for a year are graphically displayed in figure 14.

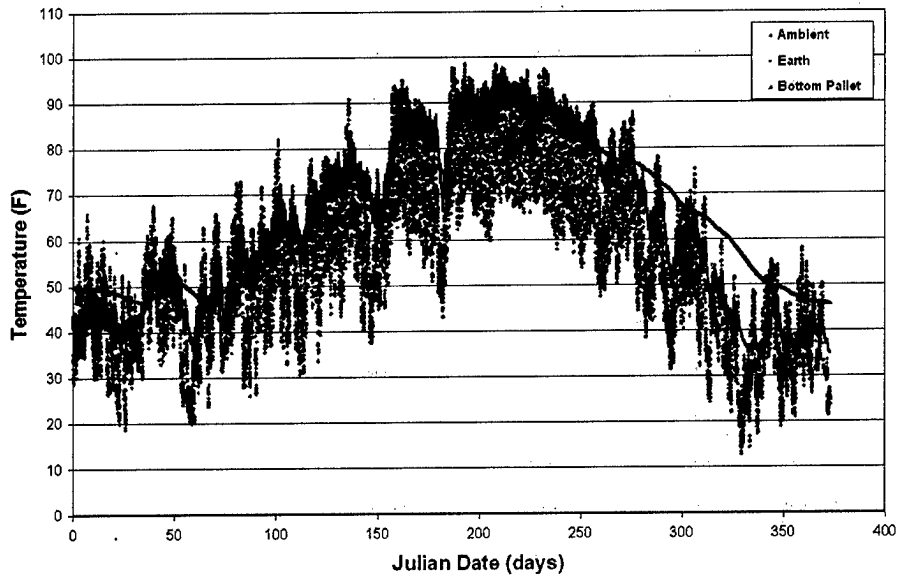

Figure 14  
Actual temperature versus Julian date

The application of equations 17 through 21 to the Hawthorne igloo example are depicted in figure 15, as modification of the previous Pro/ENGINEER schematic (fig. 9). Calculated values for ambient conditions and for each layer were included for a randomly selected point in time (Julian day 305, hour 21).

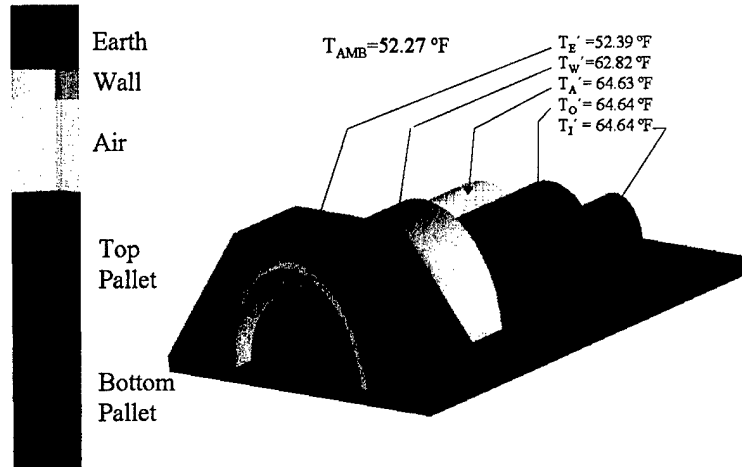

Figure 15  
Igloo heat transfer layers (Julian day 305, hour 21)

Figure 16 graphically compares the  $T_I'$  model-generated temperatures and the middle pallet location temperature measurements. Figure 16 shows only the end results of the transfer model (eq 21), which is dependent upon all previous equations. Note that the results obtained for the  $T_I'$  model are independent of the results from the middle pallet measurements. The  $T_I'$  model was developed based on the transfer models and the physical property data associated with the igloo. Whereas, the middle pallet location values are thermo-couple measurements that were obtained from the DACS website ([www.dac.army.mil](http://www.dac.army.mil)).

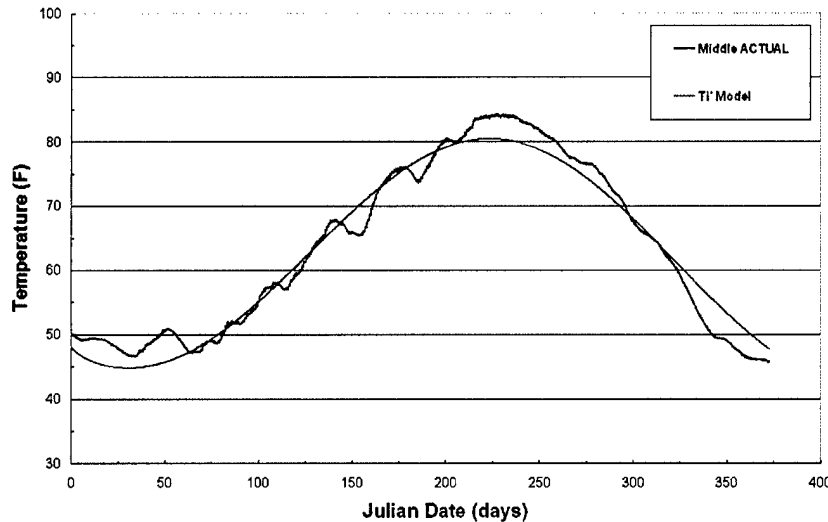

Figure 16  
Pallet temperature (actual versus model) versus Julian date

Figure 17 is a histogram that compares the  $T_i$  model temperature output to the measured middle pallet layer temperature from figure 14. The average difference between the two curves is 2.08°F and the maximum difference is 5.60°F. Note that the values in the histogram were rounded to the nearest whole number.

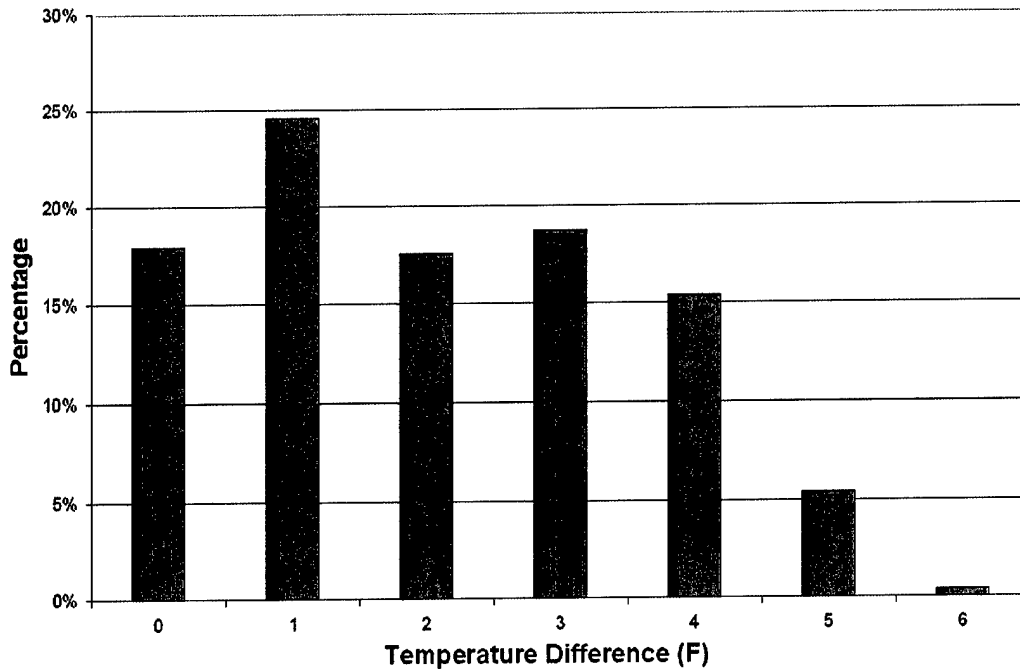

Figure 17  
Temperature difference histogram

## PREDICTIVE ENGINEERING METHODS

The Arrhenius equation is used to determine an item's degradation rate. The Life Consumed Concept calculates the amount of shelf life consumed for a given storage environment, using information from the Arrhenius equation. Two examples are provided to demonstrate the use of the Arrhenius equation and the Life Consumed Concept.

### Arrhenius Equation

The Arrhenius equation (eq 22) is used to model the dependence of an item's degradation rate constant ( $k$ ) on temperature ( $T$ ). This equation is graphed as a straight line when the logarithm of the rate constant is plotted against the reciprocal of the absolute temperature. The pre-exponential factor ( $A$ ) and the activation energy ( $E_a$ ) are calculated based on experimentally determined rate constant/temperature sets. Once  $A$  and  $E_a$  are determined for a given item, the degradation rate constant can be determined for any temperature. Once the rate constants are known, the life prediction can be calculated.

$$k = A \cdot e^{-\left(\frac{E_a}{R \cdot T}\right)} \quad (22)$$

where

- $k$  is the degradation rate constant for a given item (percent of life consumed per year)
- $A$  is the pre-exponential factor (percent of life consumed per year)
- $E_a$  is the activation energy [BTU/(lb·mol)]
- $R$  is the universal gas constant [1.9858 BTU/(lb·mol·°R)]
- $T$  is the exposure temperature (°R)

Temperatures ( $T$ ) with their corresponding degradation rate constants ( $k$ ) are inserted into the Arrhenius equation to determine  $A$  and  $E_a$ . With a minimum of two ( $T$  with  $k$ ) data sets, the  $A$  and  $E_a$  are calculated using two equations with two unknowns, by solving equation 22 for each data set.

Example: Given degradation rates ( $k$ ) for an ammunition item:

$$k_{80} = 1/0.15 \text{ (percent of life consumed/year) at } 80^\circ\text{F (corresponds to a 15-yr life)}$$

$$k_{90} = 1/0.05 \text{ (percent of life consumed/year) at } 90^\circ\text{F (corresponds to a 5-yr life)}$$

$$E_a = 64,716 \text{ BTU/(lb·mol)}$$

$$A = 1.12 \times 10^{27} \text{ (percent of life consumed/year)}$$

**Note:** The  $k_{80}$  and  $k_{90}$  values are hypothetical and selected for this conceptual example only. Actual values would be determined through an accelerated aging experiment. An accelerated aging experiment is performed on an item by placing it in a high stress (temperature) chamber for a predetermined period of time. This process is designed to simulate long-term storage effects using high stress short-term conditioning.

### Life Consumed Concept

The  $E_a$  and  $A$  values are entered into equation 23 to predict the overall life consumed. The life consumed ( $L_t$ ) is the percent of shelf life that a particular item has used. Note that equation 23 assumes that the item follows a zero-order degradation rate.

$$L_t = kt + L_0 = Ae^{-\left(\frac{E_a}{RT}\right)t} + L_0 \quad (23)$$

where

$L_t$  is the total percent of life consumed (percent)

$t$  is the exposure time (years)

$L_0$  is the initial or previous percent of life consumed (percent)

Solving equation 23 for the exposure time ( $t$ ) provides (equation 24) remaining life for a given temperature environment.

$$t = \frac{L_t - L_0}{k} = \frac{L_t - L_0}{Ae^{-\left(\frac{E_a}{R \cdot T}\right)}} \quad (24)$$

This approach allows calculations to be obtained for different degradation rates and exposure temperatures.

Example: If a newly produced item is stored for 2 yrs in a 90°F environment and then stored at 80°F, determine its remaining life for the 80°F environment by using equations 23 and 24.

Step 1:  $L_{t,90} = k_{90}t_{90} + L_0$  (eq 23)

$$L_{t,90} = \frac{1}{0.05} \cdot 2 + 0$$

$L_{t,90} = 40.0\%$ of life consumed at 90°F
--

Step 2:  $t_{80} = \frac{L_{t,80} - L_{t,90}}{k_{80}}$  (eq 24)

$$t_{80} = \frac{100 - 40.0}{1/0.15}$$

$T_{80} = 9$ yrs of life remaining at 80°F
--

If a newly produced item with the aforementioned degradation rate constants ( $k_{80}$  and  $k_{90}$ ) experiences a 2-yr deployment in a 90°F environment, it will survive nine additional years when subjected to an 80°F environment. Figure 18 graphically depicts the solution for the previous example and provides plots for the cases in which the ammunition is solely stored in 90°F or 80°F environment.

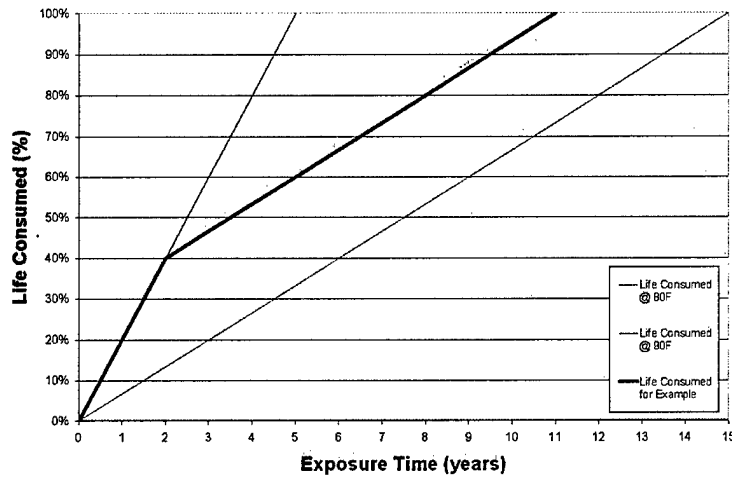

Figure 18  
Life consumed versus exposure time

As a second example, the Life Consumed Concept can be applied to calculate the difference in life consumed for items stored at Hawthorne at the two different temperature profiles. For this example, the two temperature profiles are ambient temperature ( $T_{AMB}$ ) (i.e., outside unprotected not in direct sunlight) and the outer pallet inside an igloo temperature ( $T'_O$ ). Based on the hypothetical Arrhenius rates previously calculated, the percent life consumed as a function of exposure time for the two temperature profiles is graphically presented in figure 19. Note that both plots are curves due to the changing temperature over the course of a year. The cumulative annual effect at  $T_{AMB}$  is 2.69% life consumed and at  $T'_O$  is 2.56% life consumed. By using equation 23, the  $T_{AMB}$  exposed item will have a 37-yr life and the  $T'_O$  exposed item will have a 39-yr life. For this example, the 2-yr difference in life is solely due to the different temperature profiles. The effects of solar radiation (which can be substantial), precipitation, and other environmental conditions (e.g., blowing sand and dust) would compound the degradation rate of an unprotected item.

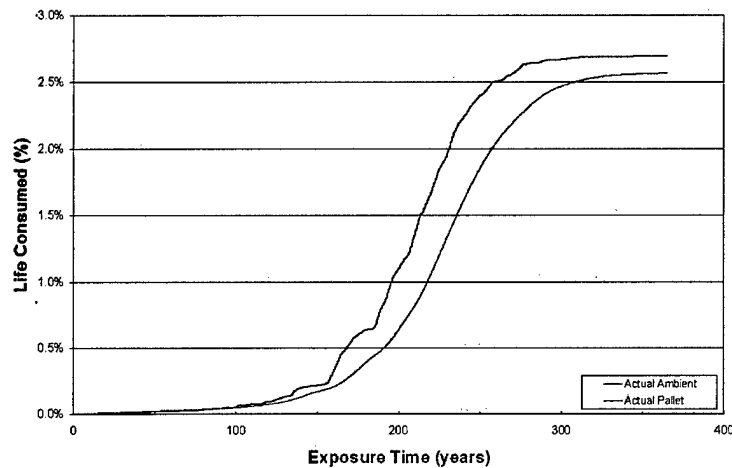

Figure 19  
Life consumed in 1 yr

## SUMMARY

By mathematically characterizing the (1) yearly ambient temperature, solar radiation and wind convection and (2) heat transfer through the layers of a storage magazine (igloo), a method was created to calculate a temperature profile for igloo stored matériel. Using the Arrhenius equation, a Life Consumed Concept was created to predict shelf life of an item as a function of its temperature. By combining these two analytical methods, an item's shelf life can be calculated based on ambient conditions and its storage facility.

The procedural notions presented in this study can be extended to include an economic analysis. An economic analysis would focus on optimization by basing logistic decisions on knowing an items shelf life.

## BIBLIOGRAPHY

1. Anderson, H. B. and Heppner, Leo, "Special Research Study on Temperature Change Versus Exposure Time for Extreme Temperature Conditioning of Artillery Ammunition," Report No. APG-MT-3571, Aberdeen Proving Ground, Maryland, July 1970.
2. "Kuwait Ammunition Temperature Monitoring Program," Validation Engineering Division Report 92-22, Summer 1992, December 1992.
3. "Environmental Monitoring of Stored Ammunition in Kuwait," Validation Engineering Division Report 93-11-3, Summer 1996, August 1997.
4. Industrial Operations Command (IOC) Storage Base, Storage Facilities, U.S. Army Defense Ammunition Center and School, February 1994.
5. Shackelford, L. F. and Alexander, W., CRC Material Science and Engineering Handbook, 1991.
6. Cengel, Yunus A., Heat Transfer: A Practical Approach, McGraw-Hill, 1998.
7. Alberty and Silbey, Physical Chemistry, John Wiley & Sons, Inc., 1997.
8. Smith, Van Ness and Abbott, Introduction to Chemical Engineering Thermodynamics, McGraw-Hill, 1996.
9. Jansen, Ted J., Solar Radiation Engineering, Prentice-Hall, Inc., 1985.
10. Headquarters Department of the Army AR 70-38, Research, Development, Test and Evaluation of Materiel for Extreme Climatic Conditions, September 1979.

**APPENDIX A**  
**PHYSICAL AND DIMENSIONAL PROPERTY VALUES**

Parameter	Ambient Condition	Earth	Wall	Air	Outer Pallet Layer
Thickness (m)		$L_E = 0.61$	$L_W = 0.61$		$L_O = 0.76$
Surface area (m <sup>2</sup> )	$A_{AMB} = 0.37$	$A_E = 0.37$	$A_W = 0.37$	$A_A = 0.37$	$A_O = 0.37$
Volume (m <sup>3</sup> )	$V_{AMB} = 0.23$	$V_E = 0.37$	$V_W = 0.23$	$V_A = 0.28$	$V_O = 0.28$
Conductivity [W/(m·K)]		$k_E = 0.27$	$k_W = 1.40$		$k_O = 237.00$
Heat capacity [J/kg·K]	$c_{AMB} = 1007$	$c_E = 800$	$c_W = 880$	$c_A = 1007$	$c_O = 903$
Density (kg/m <sup>3</sup> )	$\rho_{AMB} = 1.16$	$\rho_E = 1515.0$	$\rho_W = 2300.0$	$\rho_A = 1.16$	$\rho_O = 2702.0$

**APPENDIX B**

**ACTUAL (1 JAN 1996) VERSUS MODEL-GENERATED (DAY 1) TEMPERATURE, SOLAR  
RADIATIONS AND WIND VELOCITIES**

Julian Date and Time			Temperature (°F)		Solar Radiation (W/m <sup>2</sup> )		Wind Speed (mph)	
Days	Hours	Scaled Time (days)	Ambient	Sine Wave Model	Ambient	Sine Wave Model	Ambient	Sine Wave Model
1	0.5	0	34.11	31.73	0.0000	0.0000	4.26	3.82
1	1.0	0.021	34.27	30.60	1.0000	0.0000	3.99	3.02
1	1.5	0.043	35.38	29.61	1.0000	0.0000	4.33	2.31
1	2.0	0.064	35.09	28.78	1.0000	0.0000	4.60	1.72
1	2.5	0.085	35.01	28.12	1.0000	0.0000	3.61	1.25
1	3.0	0.106	33.88	27.64	1.0000	0.0000	3.81	0.90
1	3.5	0.128	33.67	27.35	1.0000	0.0000	5.38	0.69
1	4.0	0.149	33.61	27.25	1.0000	0.0000	7.36	0.62
1	4.5	0.170	32.07	27.35	1.0000	0.0000	3.12	0.69
1	5.0	0.181	30.96	27.64	1.0000	0.0000	1.70	0.90
1	5.5	0.213	30.47	28.12	1.0000	0.0000	2.54	1.25
1	6.0	0.234	29.85	28.78	1.0000	0.0000	4.02	1.72
1	6.5	0.255	29.33	29.61	0.0000	0.0000	3.10	2.31
1	7.0	0.277	30.31	30.60	1.0000	0.0000	5.11	3.02
1	7.5	0.298	29.84	31.73	0.0000	0.0000	5.32	3.82
1	8.0	0.319	29.93	32.97	2.0000	0.0000	3.88	4.71
1	8.5	0.340	28.83	34.31	10.0000	103.4846	4.46	5.67
1	9.0	0.362	31.63	35.73	41.0000	213.5462	5.12	6.69
1	9.5	0.383	33.99	37.20	186.0000	310.0677	3.46	7.74
1	10.0	0.404	38.35	38.69	264.0000	391.3978	0.66	8.81
1	10.5	0.426	40.24	40.19	328.0000	456.1448	0.97	9.87
1	11.0	0.447	40.27	41.66	397.0000	503.2008	2.11	10.92
1	11.5	0.468	39.87	43.07	438.0000	531.7608	2.46	11.94
1	12.0	0.489	39.83	44.42	480.0000	541.3360	4.98	12.90
1	12.5	0.511	40.25	45.66	500.0000	531.7627	2.77	13.79
1	13.0	0.532	40.68	46.79	501.0000	503.2046	3.69	14.59
1	13.5	0.553	40.70	47.77	513.0000	456.1504	3.89	15.30
1	14.0	0.574	41.11	48.61	482.0000	391.4052	6.28	15.89
1	14.5	0.596	41.06	49.27	474.0000	310.0768	4.66	16.37
1	15.0	0.617	42.20	49.75	402.0000	213.5567	6.32	16.71
1	15.5	0.638	42.60	50.04	315.0000	103.4964	6.03	16.92
1	16.0	0.660	43.52	50.14	255.0000	0.0000	5.06	16.99
1	16.5	0.681	44.32	50.04	211.0000	0.0000	3.83	16.92
1	17.0	0.702	43.80	49.75	110.0000	0.0000	6.12	16.71
1	17.5	0.723	42.51	49.27	23.0000	0.0000	4.19	16.37
1	18.0	0.745	40.93	48.61	5.0000	0.0000	5.11	15.89
1	18.5	0.766	39.86	47.77	1.0000	0.0000	3.85	15.30
1	19.0	0.787	38.44	46.79	1.0000	0.0000	3.53	14.59
1	19.5	0.809	39.48	45.66	0.0000	0.0000	2.45	13.79
1	20.0	0.830	36.99	44.42	1.0000	0.0000	4.11	12.90
1	20.5	0.851	37.55	43.07	1.0000	0.0000	6.18	11.94
1	21.0	0.872	36.91	41.66	1.0000	0.0000	4.42	10.92
1	21.5	0.894	36.20	40.19	1.0000	0.0000	4.50	9.87
1	22.0	0.915	38.36	38.69	1.0000	0.0000	3.62	8.81
1	22.5	0.936	37.67	37.20	1.0000	0.0000	7.15	7.74
1	23.0	0.957	38.44	35.73	1.0000	0.0000	4.50	6.69
1	23.5	0.979	38.47	34.31	1.0000	0.0000	4.46	5.67
1	24.0	1.000	37.81	32.97	1.0000	0.0000	4.25	4.71
2	24.5	1.021	35.54	31.71	1.0000	0.0000	3.05	3.82

**APPENDIX C**

**MODEL-GENERATED (DAY 1) TEMPERATURES FOR HAWTHORNE IGLOO LAYERS**

Julian Date and Time			Calculated Surface Temperatures (°F)				
Days	Hours	Scaled Time (days)	$T'_{EARTH}$	$T'_{WALL}$	$T'_{AIR}$	$T'_{OUTER}$	$T'_{INNER}$
1	0.5	0	44.33	46.13	47.93	49.73	51.53
1	1.0	0.021	30.61	46.12	47.92	48.16	48.61
1	1.5	0.043	29.62	46.11	47.92	47.95	48.04
1	2.0	0.064	28.79	46.10	47.91	47.92	47.93
1	2.5	0.085	28.13	46.09	47.91	47.91	47.91
1	3.0	0.106	27.65	46.07	47.90	47.90	47.90
1	3.5	0.128	27.36	46.06	47.89	47.89	47.90
1	4.0	0.149	27.25	46.05	47.89	47.89	47.89
1	4.5	0.170	27.34	46.04	47.88	47.88	47.88
1	5.0	0.181	27.63	46.02	47.87	47.88	47.88
1	5.5	0.213	28.12	46.01	47.87	47.87	47.87
1	6.0	0.234	28.78	46.00	47.86	47.86	47.86
1	6.5	0.255	29.61	45.99	47.86	47.86	47.86
1	7.0	0.277	30.60	45.98	47.85	47.85	47.85
1	7.5	0.298	31.73	45.97	47.84	47.84	47.84
1	8.0	0.319	32.97	45.96	47.84	47.84	47.84
1	8.5	0.340	38.99	45.96	47.83	47.83	47.83
1	9.0	0.362	44.63	45.96	47.82	47.83	47.83
1	9.5	0.383	49.21	45.96	47.82	47.82	47.82
1	10.0	0.404	52.90	45.96	47.81	47.81	47.81
1	10.5	0.426	55.82	45.97	47.81	47.81	47.81
1	11.0	0.447	58.06	45.98	47.80	47.80	47.80
1	11.5	0.468	59.65	45.99	47.79	47.79	47.79
1	12.0	0.489	60.65	46.00	47.79	47.79	47.79
1	12.5	0.511	61.09	46.01	47.78	47.78	47.78
1	13.0	0.532	60.98	46.02	47.78	47.78	47.78
1	13.5	0.553	60.34	46.03	47.77	47.77	47.77
1	14.0	0.574	59.18	46.03	47.76	47.76	47.76
1	14.5	0.596	57.52	46.04	47.76	47.76	47.76
1	15.0	0.617	55.38	46.05	47.75	47.75	47.75
1	15.5	0.638	52.75	46.05	47.75	47.75	47.75
1	16.0	0.660	50.14	46.06	47.74	47.74	47.74
1	16.5	0.681	50.04	46.06	47.74	47.74	47.74
1	17.0	0.702	49.75	46.06	47.73	47.73	47.73
1	17.5	0.723	49.27	46.06	47.72	47.72	47.73
1	18.0	0.745	48.61	46.06	47.72	47.72	47.72
1	18.5	0.766	47.77	46.07	47.71	47.71	47.71
1	19.0	0.787	46.79	46.07	47.71	47.71	47.71
1	19.5	0.809	45.66	46.07	47.70	47.70	47.70
1	20.0	0.830	44.42	46.06	47.70	47.70	47.70
1	20.5	0.851	43.07	46.06	47.69	47.69	47.69
1	21.0	0.872	41.66	46.06	47.69	47.69	47.69
1	21.5	0.894	40.19	46.06	47.68	47.68	47.68
1	22.0	0.915	38.69	46.05	47.67	47.68	47.68
1	22.5	0.936	37.20	46.05	47.67	47.67	47.67
1	23.0	0.957	35.73	46.04	47.66	47.66	47.66
1	23.5	0.979	34.31	46.03	47.66	47.66	47.66
1	24.0	1.000	32.97	46.02	47.65	47.65	47.65
2	24.5	1.021	31.72	46.01	47.65	47.65	47.65

**APPENDIX D**

**DERIVATION OF EQUATION 17 FROM EQUATION 7**

$$dQ_{AMB \rightarrow E} = [h_{AMB} A_{AMB} (T_{AMB} - T_E) + \alpha_E A_{AMB} SR_{AMB}] dt = V_{AMB} \rho_{AMB} c_{AMB} dT \quad (7)$$

Substitute for clarification:

$$A = h_{AMB} \cdot A_{AMB}$$

$$y_{AMB} = T_{AMB}$$

$$y = T_E$$

$$B = \alpha_E \cdot A_{AMB} \cdot SR_{AMB}$$

$$dx = dt$$

$$C = V_{AMB} \cdot \rho_{AMB} \cdot c_{AMB}$$

$$\text{Step 1: } [A(y_{AMB} - y) + B] dx = C dy$$

Rearrange and set equal to 0

$$\text{Step 2: } \frac{dy}{dx} + \frac{A}{C} y - \frac{A}{C} y_{AMB} - \frac{B}{C} = 0$$

Substitute:

$$D = \frac{A}{C}$$

$$E = -\frac{A}{C} y_{AMB} - \frac{B}{C}$$

$$\text{Step 3: } \frac{dy}{dx} + D \cdot y + E = 0$$

Rearrange to the form of  $M \cdot dx + N \cdot dy = 0$ :

$$\text{Step 4: } (D \cdot y + E) dx + dy = 0$$

In this form, the integration factor ( $\mu$ ) is equal to:

$$\mu = e^{\int f(x) dx}$$

$$\text{Where: } f(x) = \frac{1}{N} \left( \frac{\partial M}{\partial y} + \frac{\partial N}{\partial x} \right)$$

Example:  $f(x) = \frac{1}{1}(D+0) = D$

Therefore, multiply through by  $\mu = e^{Dx}$ :

Step 5:  $e^{Dx} (D \cdot y + E) dx + e^{Dx} dy = 0$

Rearrange to perform the Reverse Chain Rule on the left-hand side:

Step 6:  $e^{Dx} \frac{dy}{dx} + D \cdot y \cdot e^{Dx} = -E \cdot e^{Dx}$

Perform the Reverse Chain Rule:

Step 7:  $\frac{d(ye^{Dx})}{dx} = -E \cdot e^{Dx}$

Rearrange and integrate from  $y = y_0$  to  $y = y_1$  and from  $x = x_0$  to  $x = x_1$ :

Step 8:  $\int_{y_0}^{y_1} \frac{d(ye^{Dx})}{dx} = -E \int_{x_0}^{x_1} e^{Dx}$

Note:  $e^{Dx_0} = 1$ , since  $x_0 = 0$ :

Step 9:  $y_1 \cdot e^{Dx} - y_0 = -\frac{E}{D}(e^{Dx} - 1)$

Solve for  $y_1$ :

Step 10:  $y_1 = -\frac{E}{D}(1 - e^{Dx}) + y_0 \cdot e^{Dx}$

Substitute back to heat transfer form:

$$T'_E = y_1$$

$$T_E = y_0$$

$$U_{AMB} = D$$

$$t' = x_1$$

$$T'_E = T_E e^{-U_{AMB} t'} + \left( T_{AMB} + \frac{\alpha_E S R_{AMB}}{h_{AMB}} \right) (1 - e^{-U_{AMB} t'}) \quad (17)$$

## DISTRIBUTION LIST

Commander  
Armament Research, Development and Engineer Center  
U.S. Army Research, Development and Engineering Command  
ATTN: AMSRD-AAR-EMK (2)  
          AMSRD-AAR-GC  
          AMSRD-AAR-QES (5)  
Picatinny, NJ 07806-5000

Defense Technical Information Center (DTIC)  
ATTN: Accessions Division  
8725 John J. Kingman Road, Ste 0944  
Fort Belvoir, VA 22060-6218

Director  
U.S. Army Materiel Systems Analysis Activity  
ATTN: AMXSY-EI  
392 Hopkins Road  
Aberdeen Proving Ground, MD 21005-5071

Commander  
Soldier and Biological/Chemical Command  
ATTN: AMSSB-CII, Library  
Aberdeen Proving Ground, MD 21010-5423

Director  
U.S. Army Research Laboratory  
ATTN: AMSRL-CI-LP, Technical Library  
Bldg 4600  
Aberdeen Proving Ground, MD 21005-5066

Chief  
Benet Weapons Laboratory, AETC  
Armament Research, Development and Engineering Center  
U.S. Army Research, Development and Engineering Command  
ATTN: AMSRD-AAR-AEW (B)  
Watervliet, NY 12189-5000

Director  
U.S. Army TRADOC Analysis Center-WSMR  
ATTN: ATRC-WSS-R  
White Sands Missile Range, NM 88002

Commander  
Naval Air Warfare Center Weapons Division  
1 Administration Circle  
ATTN: Code 473C1D (2)  
China Lake, CA 93555-6001

Chemical Propulsion Information Agency  
ATTN: Accessions  
10630 Little Patuxent Parkway, Ste 202  
Columbia, MD 21044-3204

GIDEP Operations Center  
PO Box 8000  
Corona, VA 91718-8000