

AD \_\_\_\_\_

Award Number: DAMD17-02-2-0040

TITLE: Far Forward Battlefield Telemedicine: Ultrasonic Guidance  
in Diagnosis and Emergency Therapeutics

PRINCIPAL INVESTIGATOR: James D. Thomas, M.D.

CONTRACTING ORGANIZATION: Cleveland Clinic Foundation  
Cleveland, OH 44195

REPORT DATE: September 2003

TYPE OF REPORT: Annual

PREPARED FOR: U.S. Army Medical Research and Materiel Command  
Fort Detrick, Maryland 21702-5012

DISTRIBUTION STATEMENT: Approved for Public Release;  
Distribution Unlimited

The views, opinions and/or findings contained in this report are those of the author(s) and should not be construed as an official Department of the Army position, policy or decision unless so designated by other documentation.

20040311 155

# REPORT DOCUMENTATION PAGE

*Form Approved*  
OMB No. 074-0188

Public reporting burden for this collection of information is estimated to average 1 hour per response, including the time for reviewing instructions, searching existing data sources, gathering and maintaining the data needed, and completing and reviewing this collection of information. Send comments regarding this burden estimate or any other aspect of this collection of information, including suggestions for reducing this burden to Washington Headquarters Services, Directorate for Information Operations and Reports, 1215 Jefferson Davis Highway, Suite 1204, Arlington, VA 22202-4302, and to the Office of Management and Budget, Paperwork Reduction Project (0704-0188), Washington, DC 20503

<b>1. AGENCY USE ONLY</b> (Leave blank)	<b>2. REPORT DATE</b> September 2003	<b>3. REPORT TYPE AND DATES COVERED</b> Annual (15 Aug 2002 - 14 Aug 2003)
--	---	---

<b>4. TITLE AND SUBTITLE</b>  Far Forward Battlefield Telemedicine: Ultrasonic Guidance in Diagnosis and Emergency Therapeutics	<b>5. FUNDING NUMBERS</b>  DAMD17-02-2-0040
---	---

<b>6. AUTHOR(S)</b>  James D. Thomas, M.D.	
--	--

<b>7. PERFORMING ORGANIZATION NAME(S) AND ADDRESS(ES)</b>  Cleveland Clinic Foundation Cleveland, OH 44195  E-Mail: thomasj@ccf.org	<b>8. PERFORMING ORGANIZATION REPORT NUMBER</b>
--	---

<b>9. SPONSORING / MONITORING AGENCY NAME(S) AND ADDRESS(ES)</b>  U.S. Army Medical Research and Materiel Command Fort Detrick, Maryland 21702-5012	<b>10. SPONSORING / MONITORING AGENCY REPORT NUMBER</b>
--	---

**11. SUPPLEMENTARY NOTES**

<b>12a. DISTRIBUTION / AVAILABILITY STATEMENT</b> Approved for Public Release; Distribution Unlimited	<b>12b. DISTRIBUTION CODE</b>
--	-------------------------------

**13. ABSTRACT (Maximum 200 Words)**

To improve battlefield assessment of injured personnel we are exploiting several convergent trends in medicine and technology, including ultrasound miniaturization and wireless connectivity. Specific aims include (1) validation of portable ultrasound to diagnose cardiac tamponade, pneumothorax, intraabdominal hemorrhage, etc.; (2) extension of digital echocardiography and local telemedicine to assist remote centers in transesophageal echocardiography; (3) Development of wireless telemedicine systems to relay ultrasonic images and loops to a remote review station; (4) Development of a precision guide for percutaneous drainage procedures using ultrasound guidance; (5) Combining this guide with wireless telemetry for remotely guided drainage; and (6) Extending this work to real-time three-dimensional ultrasonography. The technical and clinical challenges of such a proposal are complex but we have made significant progress on all aims, with wireless telemetry of continuous ultrasound data already a reality. If these goals can be accomplished, the ability of the Department of Defense to reduce mortality from battlefield trauma will be greatly enhanced. While this project has been developed specifically for battlefield telemedicine, the tools and techniques developed herein will have enormous application in the civilian sector, including delivery of diagnostic services to remote towns with little or no hardware access to the internet.

<b>14. SUBJECT TERMS</b> Telemedicine, Ultrasound, Diagnosis, Therapeutics, Trauma, Wireless Communication	<b>15. NUMBER OF PAGES</b> 14
---	----------------------------------

	<b>16. PRICE CODE</b>
--	-----------------------

<b>17. SECURITY CLASSIFICATION OF REPORT</b> Unclassified	<b>18. SECURITY CLASSIFICATION OF THIS PAGE</b> Unclassified	<b>19. SECURITY CLASSIFICATION OF ABSTRACT</b> Unclassified	<b>20. LIMITATION OF ABSTRACT</b> Unlimited
--	---	--	--

## Table of Contents

Cover Page.....	1
Standard Form 298 .....	2
Table of Contents .....	3
Introduction .....	4
Body .....	5
Specific Aim #1: Validation of small portable ultrasound units.....	5
Specific Aim #2: Telemedicine extension .....	6
Specific Aim #3: Development of wireless telemedicine systems for ultrasound.....	7
Specific Aim #4: Development of ultrasound guide for percutaneous procedures .....	10
Specific Aim #5: Combining wireless telemetry with ultrasound guide .....	12
Specific Aim #6: Augmenting work with emerging three-dimensional ultrasonography.....	12
Key Research Accomplishments.....	12
Reportable Outcomes .....	12
Conclusions .....	12
References.....	13

## Introduction

Modern medical and surgical therapy has made great strides in reducing the mortality of battlefield trauma. Key to this has been rapid assessment of soldiers on the battlefield, delivery of emergency therapy on-site, and triage and transport of the most severely injured soldiers to medical units where definitive care can be provided. In the past, the on-site assessment of injured personnel has been based mainly on personal inspection by medics, with relatively little support from fully trained physicians who cannot be on site. Fortunately, there are several convergent trends in medicine and technology that, if brought together, will significantly improve the ability of medics to deliver care on the battlefield and identify those soldiers most urgently in need of emergency evacuation. Among these convergent trends are the following:

- 1) ultrasound has emerged as the most commonly applied diagnostic imaging test with applications to injuries of the chest, abdomen, vasculature, and musculoskeletal system;
- 2) miniaturization has led to high quality ultrasound imaging equipment with weight of under six pounds that can be carried onto the battlefield;
- 3) an internationally agreed-to standard for digital file storage that has led to all digital ultrasonography;
- 4) the growth of the internet and other networked applications has allowed remote telemedicine using ultrasound;
- 5) the explosion in wireless telemetry and bandwidth should allow telemedicine applications in remote areas unserved by hardwired networks;
- 6) ultrasound is now routinely used to guide therapeutic interventions, with further automation possible for remote guidance;
- 7) as ultrasound technology advances, real-time three-dimensional ultrasonography will emerge as a standard of acquisition which should simplify the problem of poorly trained individuals acquiring images of diagnostic quality.

Members of the Cardiovascular Imaging Center of the Cleveland Clinic Foundation have had extensive experience in each of these areas, and have led national and international development of several of them. In this application, we hope to use this expertise to support the following broad goal:

### **To improve survival of battlefield trauma through ultrasound telemedicine and remotely guided therapeutics.**

We propose to address this goal with the following specific aims:

1. Validation of small portable ultrasound units for the diagnosis of various medical and surgical emergencies, including cardiac tamponade, pneumothorax, and intraabdominal hemorrhage.
2. Extension of our extensive experience in digital echocardiography and local telemedicine to support centers of intermediate expertise in such sophisticated diagnostic maneuvers as transesophageal echocardiography.
3. Development of wireless telemedicine systems for the rapid relay of ultrasonic images and loops from a small portable ultrasound system to a remote review station.
4. Development of a precision guide for diagnostic and therapeutic percutaneous procedures using ultrasound guidance. Such a device could be used for emergency pericardiocentesis, thoracentesis, paracentesis, arthrocentesis, and obtaining vascular access.
5. Combining wireless telemetry with this guided percutaneous access tool to permit remotely guided evacuation of pericardial effusions and other emergency procedures.

6. Augmenting this work, which will be conducted initially with two-dimensional ultrasound imaging equipment, with emerging real-time three-dimensional ultrasonography.

The technical and clinical challenges of such a proposal are complex and not easily accomplished. Nonetheless, we believe that accomplishments in recent years have set the stage for pulling together technological advances from several fields to develop a system of natural synergy in the delivery of battlefield medicine. If these goals can be accomplished, the ability of the Department of Defense to reduce mortality from battlefield trauma will be greatly enhanced.

**Civilian Applications:** While this project is developed with the specific goal in mind of battlefield telemedicine, it will be readily apparent that the tools and techniques developed herein will have enormous application in the civilian sector. As mentioned above, ultrasound has become the most commonly used cardiac imaging test and is widely used in abdominal, vascular, and musculoskeletal disease. A key limitation to its further use is the need for on-site expertise in both its performance and interpretation. Through the tools developed in this proposal, we hope to greatly enhance the utility of ultrasound in medicine throughout the United States and the world. This will include delivery of diagnostic services to remote towns with little or no hardwire access to the Internet.

## Body

### Specific Aim #1: Validation of small portable ultrasound units

Although small ultrasound systems have been introduced by several vendors, relatively few data exist regarding their accuracy in a variety of medical disorders. Furthermore, there are scarcely any data comparing these systems. In a field as rapidly developing as this one, it is critical to develop metrics of usability and accuracy so that the proper choice in instrument can be made for a particular application.

To date we have examined the following systems: SonoHeart (SonoSite, Bothell, WA); Optigo (Philips, Andover, MA); Cypress (Siemens, Mountain View, CA). In the upcoming months we will evaluate the Terason (Teratech, Billerica, MA) and the Logicbook (GE, Milwaukee, WI). These miniature echo machines have been surveyed (**Table 1 and Table 2**) for such features as 1) weight; 2) battery life; 3) boot-up time; 4) screen luminosity and visibility under a variety of lighting conditions; 5) available imaging modalities (2D imaging, color flow Doppler, pulsed wave Doppler, continuous wave Doppler, M-mode with and without color Doppler); 6) completeness of measurement package; 7) output capabilities (analog video, digital still and movie export, adherence to the DICOM standard); 8) image resolution from a standard ultrasound phantom. In addition, the ease of use both initially and after a period of training has been evaluated by a team of experienced sonographers as well as novices to ultrasound.

**Table 1:** Comparison Of Portable Ultrasound Devices (Part 1: Data)

Portable System	Manufacturer	Battery	Video Output	DICOM compliant	Integrated Wireless	Digital Export
Cypress	Siemens	none	yes	yes	no	images/movie
SonoHeart	Sonosite	rechargeable lithium ion	yes	no	no	images
Optigo	Philips		no	no	no	images
LogicBook	GE	unknown	unknown	yes	yes	images/movie
Terason	Teretec	rechargeable lithium ion	*yes	yes	*yes	images/movie

\* laptop configured for video output and wireless networking

**Table 2: Comparison Of Portable Ultrasound Devices (Part 2: Performance)**

<b>Portable System</b>	<b>Manufacturer</b>	<b>Boot Time</b>	<b>Weight</b>	<b>Image Quality</b>	<b>Measurement Package</b>
Cypress	Seimens	1 minute	21 lbs	Good	Moderate
SonoHeart	Sonosite	5 seconds	5.6 lbs	Good	Minimal
Optigo	Philips	2 seconds	7.6 lbs	Poor	Minimal
LogicBook	GE	Unknown	Unknown	Unknown	Unknown
Terason	Teretec	Unknown	Unknown	Unknown	Unknown

Experimental testing to assess their diagnostic capabilities has also been initiated. For cardiac assessment, 20 patients scheduled for a clinical echocardiographic study have participated, undergoing both a standard imaging exam as well as one with a portable system. Assuming the full-sized system to be the reference standard, paired t-testing and linear regression will be used to test the hypothesis that the small system is equivalent to the full-featured one (mean difference in values not different from 0 and slope of the regression line not different from 1).

**Specific Aim #2: Telemedicine extension**

Our goal is to extend the capabilities of our digital echocardiographic laboratory<sup>1</sup> beyond the Cleveland Clinic main campus. We have established digital connectivity with 5 satellite clinics up to 100 km from the main campus. Together, these sites generate approximately 20 echocardiographic studies per day requiring transfer of around 1 GB of echo data to our archive over T1 and T3 lines. (This is in addition to the 200 studies and 20 GB data generated on the main campus itself). We have also worked to establish secure connectivity for transfer of ultrasound data outside the Cleveland Clinic Health System. Connectivity using a VPN (virtual private networking) protocol is currently utilized, allowing for secure, encrypted transfer of data to anywhere with Internet connectivity, preferably high bandwidth. Using the VPN 50 MB studies have been transferred to Europe in 5 minutes, allowing remote consultation and diagnosis. We have also explored the deployment of server technology outside the CCF infrastructure to allow connectivity to specific sources. We will continue to utilize these technologies for telemedicine applications.

**Specific Aim #3: Development of wireless telemedicine systems for ultrasound**

We explored solutions from vendors that may allow wireless transfer of ultrasound data. We have evaluated many currently available technologies (Table 3) including Bluetooth, 802.11a, 802.11b, 802.11g.

**Table 3:** Comparison Of Available Wireless Technologies

	<b>Bluetooth</b>	<b>802.11a</b>	<b>802.11b</b>	<b>802.11g</b>
Cost	\$\$	\$\$\$\$	\$	\$\$
Max Data Rate	20Mbps	54Mbps	22 Mps	54 Mbps
Range (full speed)	30 ft	150 ft	150 ft	150 ft
Compatible w/ 802.11b	N	N	Y	Y
Available for pocket PC	Y	N	Y	N
Likely radio interference with other equipment	Low (because of short range)	Low (Because of higher Freq) Carrier =5 GHz	Med-High Long range + 2.4 GHz is used by other devices	Med-High Long range + 2.4 GHz is used by other devices

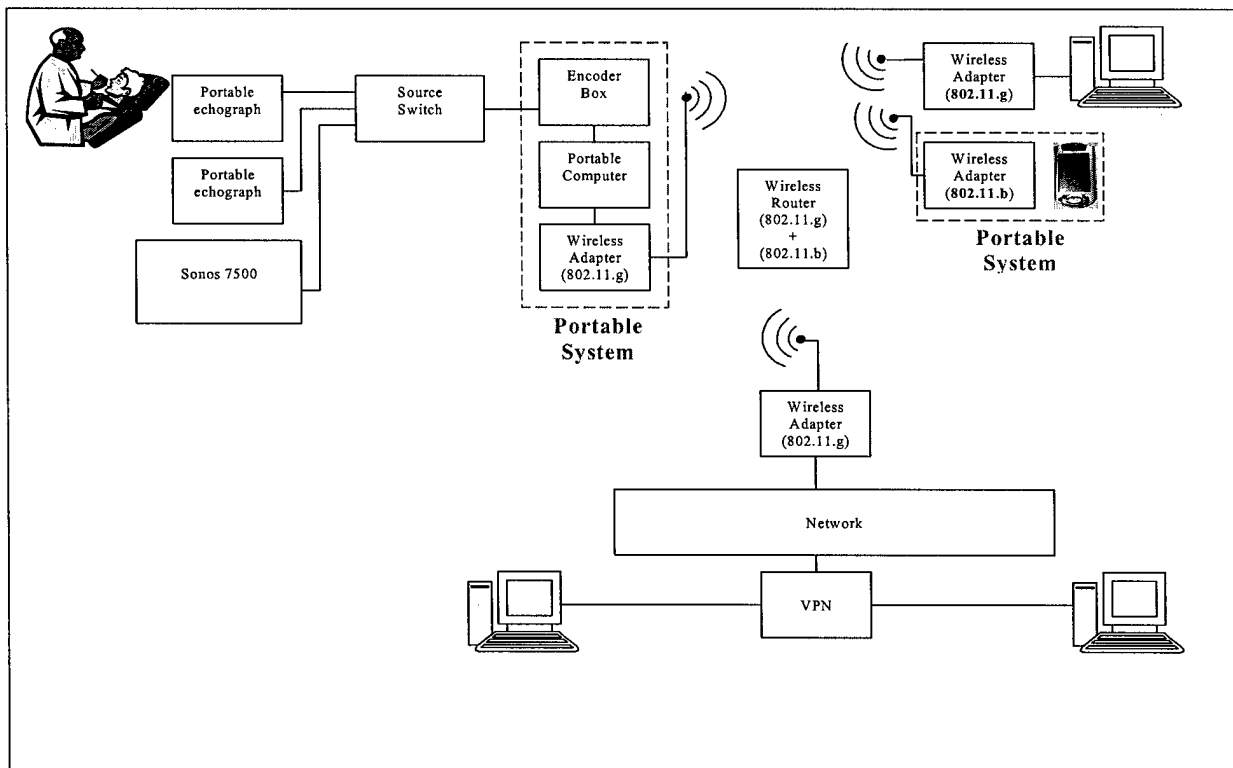

**Figure 1:** Wireless Testbed for evaluation of telemedicine systems for ultrasound

We chose to base the test infrastructure on the standard 802.11g because, not only does it offer the same speed of 802.11a at a fraction of the cost, but also it enables integration the inexpensive 802.11b standard available even for the Windows CE platform. This factor revealed the 802.11.g technology as the winning choice enabling flexible expansion of the network with great control over costs. The 802.11b standard is ideal for deployment of low bit-rate video streams over an expanded

range. Nominally 802.11b is able to transfer data wirelessly up 430 ft from the access point at a reasonable speed of 2 Mbps.

Mixing the 802.11.b standards and 802.11.g standards has a negative impact over the overall responsiveness of the dual standard router due to the different protocols that the router has to handle. The encouraging results obtained in our initial wireless testbed (**Figure 1**) allowed us to plan for an improved and more comprehensive wireless infrastructure. We will overcome the limitation due to the dual standard by installing several routers with different pass phrases. This will enable us to selectively enable/disable access of wireless devices to selected routers, thereby improving overall system performance, a prerequisite for our goal of wireless transmission of DVD-quality video (640x480 @30fps). Additionally, we will include simultaneous digital video channels in our wireless network supported by a dedicated media server and web server to provide a user interface to the each channel. To test the multi-channel solution, we will use the existing analog infrastructure currently able to deploy analog video signals from many locations to one specific location within our echocardiography laboratory. We will seamlessly integrate deployment of digital streams into a web based user interface accessible from multi-platform devices (Win CE, Windows, etc).

The acquisition board currently used is the Hauppauge PC/TV pro. Since it is USB powered, this solution enabled us to perform an entirely wirelessly acquired echocardiographic examination. In our lab, our physicians were successfully able to read and interpret examinations acquired and transmitted at VHS quality (320x200 @ 30fps). The minimum requirement for such acquisition was a PII 366 MHz with 256 Mb Ram. Our tests showed the ideal encoding standard is currently the Microsoft MP4 at 600 Kbit with key-frame generated every 5 seconds.

Among the video streaming software solutions evaluated were: Microsoft Media Encoder, Microsoft Media Server, and Microsoft Media Player for Windows and Pocket PC. This solution has the advantages that video can be easily integrated within web pages (multi-platform visualization), Windows media player is included in Win CE 3.0 (no extra software needed), and Windows Media Server License is included with Windows 2000 Professional Server Edition. An alternative solution to be investigated would utilize the Apple Quick Time Encoder, the Darwin Streaming Server, Quicktime player for PC and PictPocket Cinema 3.0 for PocketPC.

The creation of a wireless test bed within the echocardiography laboratory has been implemented. This wireless network enables us to transfer within the hospital and remotely to workstations connected to our network through a Virtual Private Network (VPN) protocol. The testbed includes wireless connection to desktop PC (802.11g 54Mbits with max-range: 75-150 ft), wireless connection to handheld PC (802.11b within range 75-150 ft), wired connection to local PC (TCP/IP 100 mbits) and wired connection to remote PC through VPN.

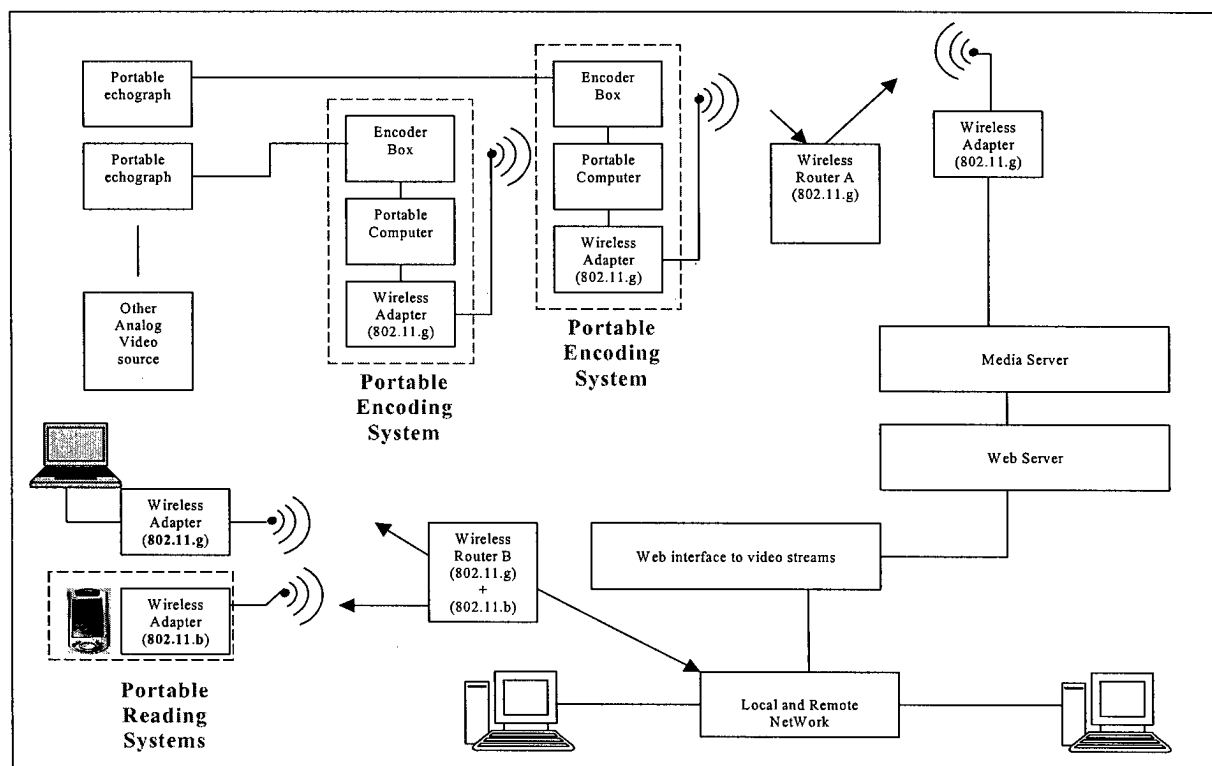

**Figure 2:** Wireless Echocardiographic exam review using windows CE devices

We conducted a preliminary study of 5 patients imaged using a portable device. Images were encoded using windows media encoder (VHS quality  $320 \times 200 @ 30 \text{fps}$ ) using different codecs WM7, WM8, DivX 5, and Microsoft MP4. The transmission bit rate ranged from 150 kbits to 2000 kbits during wireless transfer of streaming video to a Compaq HP3800. We obtained successful visualization on Pocket PC using Microsoft Media Player with maximal bit rates  $< 1500 \text{kbits}$ . However, the Windows CE 3.0 handheld (Compaq HP 3800) was not able to correctly process the video stream at a frame rate of 30 fps. Even at a low bit rate, streaming resulted in frequent interruption (freezing) of full motion video, which resulted in difficult diagnostic reading on the WinCE device. On the other hand, visualization of the same streams were flawless, in all tests, on a wirelessly connected desktop computer running Windows 2000 Professional. Therefore, we can conclude that our system was capable of successfully sending wireless VHS quality video streams.

The WinCE handheld was able to flawlessly play video content with max frame rate of 15 fps. We identified the limitation in the video subsystem of the WinCE handheld. In our experiments, diagnostic reading of streamed videos at 15 fps was found possible although the evaluation of valve function was sometimes challenging. This justifies the need to overcome the limitation in the frame rate. Further research in various software solutions from vendors indicated that it is technically possible to play videos on WinCE platform with frame rate greater than 15 fps. In fact, using Pocket TV MPEG in our lab, we were able to play a previously recorded video of echocardiographic examination at 24 fps. Further research and testing are required in order to transcend the limits of the currently available hardware/software solution.

We are currently exploring solutions to wireless stream video with DVD quality ( $640 \times 480 @ 30 \text{fps}$ ). We plan to test newer analog video capturing devices with hardware encoding capabilities. "Video\_OH!" by Adaptec, and Hauppauge WinTV PVR2 have been identified as potential portable hardware solution to be integrated in our solution. Furthermore, we plan to test a software solution that takes advantage of newer technology to deploy video streams over the wireless test bed.

Additionally, we have begun a collaboration with Kevin Montgomery of the Stanford Biocomputation Center and John Hines of NASA Ames Research Center. They have developed server technology for the wireless detection and transmission of physiologic and electrocardiographic information applicable to DoD. We will capitalize on the expertise in each of our groups to deliver full motion echocardiographic studies using the Ames/Stanford server platform. One potential advantage is that this implementation may provide a real-time stream of ultrasound data with only a very small (<1 second) delay. We have the software components (switchboard, encoder, viewer) installed on both desktop workstations and IPAQ devices and will be including an evaluation of this infrastructure in parallel with other test platforms.

#### **Specific Aim #4: Development of ultrasound guide for percutaneous procedures**

The Ultrasound Guided System (UGS) has been designed and prototyped. It consists of: a) a plastic frame that is shaped to fit most cardiac ultrasound imaging transducers, b) an angle-adjustable needle carrier that pivots over a fixed point attached to the frame, c) a depth guide for needle advancement, d) an 18-gauge 15cm angle tip needle with an internal removable stylet, and e) sterile sleeve and straps (**Figure 3**). The angle of the needle carrier can be adjusted from 10 to 60° at fixed increments and the length of the needle allows penetration to targets located up to 10 cm depth from the skin surface.

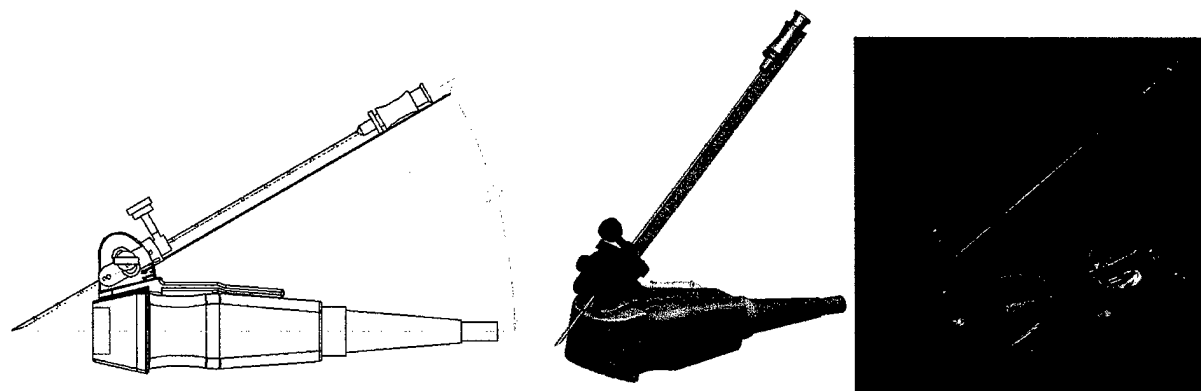
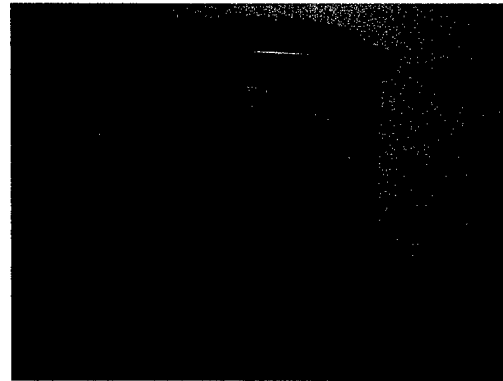
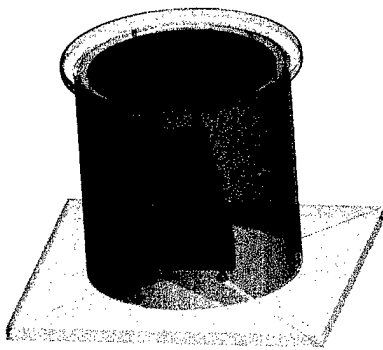

**Figure 3:** Ultrasound Guided System (UGS) design and prototype

The location of the target (fluid collection) is determined based on axial ultrasound measurements. Using a table guide (**Table 4**), the angle and penetrating distance is calculated. The needle carrier is then fixed at the appropriate angle and the needle is introduced. Two-dimensional imaging is then repeated until the target is detected. Under direct live visualization, the needle and stylet are advanced to the depth determined according to the table guide.

**Table 4: Targeting Guide**

$\theta$ (deg)	$\delta$ (cm)	Distance from US face (cm)
15	7.6	7.1
20	5.6	5.1
25	4.5	3.8
30	3.7	3.0
35	3.2	2.3
40	2.8	1.9
45	2.5	1.5
50	2.3	1.1



**Figure 4: Design diagram and constructed Target phantom**

A series of *in vitro* experiments are underway to test the accuracy of the UGS-guided endocentesis. A target phantom has been designed and built for these experiments (**Figure 4**). This phantom consists of a tank that allows ultrasound conductivity and is covered by a membrane to function as the skin. An inner apparatus is customizable to allow configurations to locate targets at various depths through various layers. A sample target is shown in **Figure 5**. The layers can be filled with solutions of various colored solutions to allow indication of success/failure in the test procedures to withdraw fluid from the test targets.

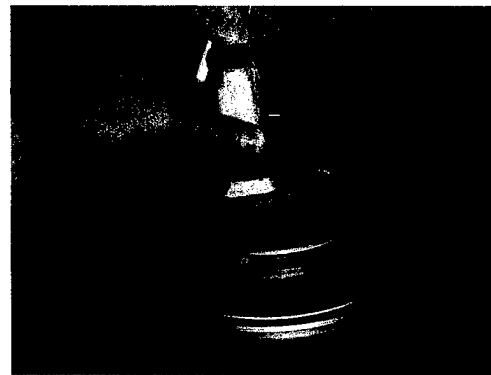
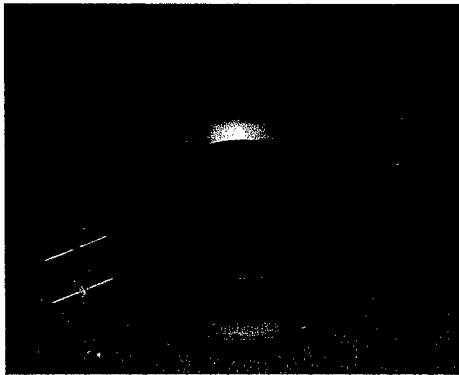

**Figure 5: Sample target (object filled with blue die) located within a layer of the phantom (left) and utilized in evaluation test as shown (right)**

### **Specific Aim #5: Combining wireless telemetry with ultrasound guide**

This work has not yet been begun. The last phase of testing with the UGS will be done by novice users with remote guidance provided by wireless transmission of ultrasound data.

### **Specific Aim #6: Augmenting work with emerging three-dimensional ultrasonography**

Our group has continued to investigate three-dimensional ultrasound capabilities. To date we have performed over 2500 patient examinations with real-time 3D echocardiography, including exercise and intraoperative (epicardial) examinations, with quantitative validation in aneurysmal ventricles,<sup>2</sup> aortic regurgitation,<sup>3</sup> hypertrophic cardiomyopathy,<sup>4</sup> mitral regurgitation,<sup>5</sup> ischemic cardiomyopathy,<sup>6</sup> and dilated cardiomyopathy.<sup>7</sup> We validated 3D color Doppler stroke volume<sup>8</sup> as well as 3D reconstruction using a device identical to the ultrasound system on the ISS. Building on our experience with the Volumetrics RT3DUS, we have begun to use a much improved acquisition device (Sonos 7500) to obtain over 100 RT3D examinations in a wide variety of cardiac pathologies, including 28 acquisitions obtained epicardially in the operating room. Already, six abstract presentations and a journal article have resulted from this work including volume assessment validation, valvular assessment for surgical planning compared to standard 2D imaging, and surgical outcome results of myectomy in patients with hypertrophic cardiomyopathy<sup>9-15</sup> We have also worked to improve visualization techniques that may allow wireless transfer and display.<sup>16</sup>

### **Key Research Accomplishments**

- Investigation of portable ultrasound devices
- Wireless Testbed for assessment of ultrasound data transmission
- Development of ultrasound guidance system and test phantom
- Utilization of 3D ultrasound technology for clinical cardiac assessment

### **Reportable Outcomes**

While we have not reported on our investigation of the available portable ultrasound devices for their performance and capabilities, we anticipate that we will be able to do so within the next several months as we evaluate several additional products. In addition to the validation of these devices for diagnosis of various medical and surgical emergencies, we will be able to evaluate their ability to provide wireless transmission of ultrasound data.

### **Conclusions**

When completed, our aims will allow us to recommend to the Department of Defense a small ultrasound system for further testing in field situations. There may be more than one recommendation depending on the anticipated use. The exploration of wireless network configurations will be an ongoing experiment in and effort to optimize long-distance transmissions of these data sets utilizing the current technologies. When successfully completed, we will be able to recommend network configurations that optimize long-distance tele-echocardiography in both military and civilian situations and for both store-and-forward and real-time communication models. The engineering validation of the UGS will permit refinement of the design; while the clinical testing will lend confidence that this can be used in a variety of medical conditions. Furthermore, the experience gained in these aspirations will allow us to develop teaching tools that can be used to instruct less experienced operators, such as field medics.

## References

1. Thomas JD, Greenberg NL, Garcia MJ. Digital echocardiography 2002: Now is the time. *J Am Soc Echocardiogr.* 2002;15:831-8.
2. Qin JX, Jones M, Shiota T, Greenberg NL, Tsujino H, Firstenberg MS, Gupta PC, Zetts AD, Xu Y, Ping Sun J, Cardon LA, Odabashian JA, Flamm SD, White RD, Panza JA, Thomas JD. Validation of real-time three-dimensional echocardiography for quantifying left ventricular volumes in the presence of a left ventricular aneurysm: in vitro and in vivo studies. *J Am Coll Cardiol.* 2000;36:900-7.
3. Shiota T, Jones M, Tsujino H, Qin JX, Zetts AD, Greenberg NL, Cardon LA, Panza JA, Thomas JD. Quantitative analysis of aortic regurgitation: real-time 3-dimensional and 2-dimensional color Doppler echocardiographic method--a clinical and a chronic animal study. *J Am Soc Echocardiogr.* 2002;15:966-71.
4. Qin JX, Shiota T, Lever HM, Rubin DN, Bauer F, Kim YJ, Sitges M, Greenberg NL, Drinko JK, Martin M, Agler DA, Thomas JD. Impact of left ventricular outflow tract area on systolic outflow velocity in hypertrophic cardiomyopathy: a real-time three-dimensional echocardiographic study. *J Am Coll Cardiol.* 2002;39:308-14.
5. Gillinov AM, Cosgrove DM, 3rd, Shiota T, Qin J, Tsujino H, Stewart WJ, Thomas JD, Porqueddu M, White JA, Blackstone EH. Cosgrove-Edwards Annuloplasty System: midterm results. *Ann Thorac Surg.* 2000;69:717-21.
6. Qin JX, Shiota T, McCarthy PM, Asher CR, Hail M, Agler DA, Popovic ZB, Greenberg NL, Smedira NG, Starling RC, Young JB, Thomas JD. Importance of mitral valve repair associated with left ventricular reconstruction for patients with ischemic cardiomyopathy: a real-time three-dimensional echocardiographic study. *Circulation.* 2003;108 Suppl 1:II241-6.
7. McCarthy PM, Takagaki M, Ochiai Y, Young JB, Tabata T, Shiota T, Qin JX, Thomas JD, Mortier TJ, Schroeder RF, Schweich CJ, Jr., Fukamachi K. Device-based change in left ventricular shape: a new concept for the treatment of dilated cardiomyopathy. *J Thorac Cardiovasc Surg.* 2001;122:482-90.
8. Tsujino H, Jones M, Shiota T, Qin JX, Greenberg NL, Cardon LA, Morehead AJ, Zetts AD, Travaglini A, Bauer F, Panza JA, Thomas JD. Real-time three-dimensional color Doppler echocardiography for characterizing the spatial velocity distribution and quantifying the peak flow rate in the left ventricular outflow tract. *Ultrasound Med Biol.* 2001;27:69-74.
9. Agler D, Qin J, Shiota T, Shin J, Kassimatis C, Nash P, Oryszak S, Pettersson G, Griffin B, Grimm R, Thomas J. Aortic Abnormalities Determined by Live 3D Echo: Comparison with 2D Echocardiographic Study. *J Am Soc Echocardiogr.* 2003;16:501.
10. Agler D, Qin J, Shiota T, Shin J, Nash P, Morehead A, Greenberg N, Stewart W, Cosgrove DI, Thomas J. Initial Experience of Epicardial Live 3D Echo for Determining Mitral Valvular Pathology: Operative Validation. *J Am Soc Echocardiogr.* 2003;16:501.
11. Qin J, Shiota T, Shin J-H, Agler D, Borowski A, Grimm R, Wilkoff B, Thomas J. Tracking Pacemaker Wire and Lead in Patients with Permanent Right Ventricular Pacing by Live 3D Echo: Comparison with 2D Echo. *J Am Soc Echocardiogr.* 2003;16:551.
12. Qin J, Shiota T, Shin J-H, Agler D, Drinko J, Nash P, Smedira N, Asher C, Lever H, Thomas J. Quantification of Left Ventricular Outflow Tract by Live 3D Echo in Patients with Hypertrophic Cardiomyopathy. *J Am Soc Echocardiogr.* 2003;16:546.
13. Shin J-H, Shiota T, Qin J, Agler D, Greenberg N, Oryszak S, Martin M, Nash P, Eto Y, Thomas J. Reproducibility of Live Three-Dimensional Echocardiography in Measurement of Left Ventricular Volumes. *J Am Soc Echocardiogr.* 2003;16:551.
14. Shin J-H, Shiota T, Qin J, Agler D, Greenberg N, Oryszak S, Nash P, Eto Y, Thomas J. Validation of Live Three-Dimensional Echocardiography for Quantification of Left Ventricular Volume: Comparison with Volumetric Real-Time Three-Dimensional Echocardiography. *J Am Soc Echocardiogr.* 2003;16:552.
15. Nash PG AD, Shin JH, Qin JX, Smedira NG, Lever HM, Shiota T, Thomas JD. Epicardial Real Time 3-D Echocardiography During Septal Myectomy for Obstructive Hypertrophic Cardiomyopathy. *Circulation.* 2003;(in press).
16. Saracino G, Greenberg N, Shiota T, Corsi C, Lamberti C, Thomas JD. Fast Interactive Real-time Volume Rendering of Real-time Three-dimensional Echocardiography: an Implementation for Low-end Computers. *Computers in Cardiology.* 2002;29:613-616.