

AD \_\_\_\_\_

Award Number: DAMD17-01-1-0725

TITLE: Cyclin Dependent Kinase Inhibitors as Targets in Ovarian  
Cancer

PRINCIPAL INVESTIGATOR: Stephen D. Williams, M.D.

CONTRACTING ORGANIZATION: Indiana University  
Indianapolis, Indiana 46202-5167

REPORT DATE: October 2003

TYPE OF REPORT: Annual

PREPARED FOR: U.S. Army Medical Research and Materiel Command  
Fort Detrick, Maryland 21702-5012

DISTRIBUTION STATEMENT: Approved for Public Release;  
Distribution Unlimited

The views, opinions and/or findings contained in this report are those of the author(s) and should not be construed as an official Department of the Army position, policy or decision unless so designated by other documentation.

20040317 016

# REPORT DOCUMENTATION PAGE

Form Approved  
OMB No. 074-0188

Public reporting burden for this collection of information is estimated to average 1 hour per response, including the time for reviewing instructions, searching existing data sources, gathering and maintaining the data needed, and completing and reviewing this collection of information. Send comments regarding this burden estimate or any other aspect of this collection of information, including suggestions for reducing this burden to Washington Headquarters Services, Directorate for Information Operations and Reports, 1215 Jefferson Davis Highway, Suite 1204, Arlington, VA 22202-4302, and to the Office of Management and Budget, Paperwork Reduction Project (0704-0188), Washington, DC 20503

**1. AGENCY USE ONLY**  
(Leave blank)

**2. REPORT DATE**  
October 2003

**3. REPORT TYPE AND DATES COVERED**  
Annual (29 Sep 2002 - 28 Sep 2003)

**4. TITLE AND SUBTITLE**

Cyclin Dependent Kinase Inhibitors as Targets in Ovarian Cancer

**5. FUNDING NUMBERS**  
DAMD17-01-1-0725

**6. AUTHOR(S)**

Stephen D. Williams, M.D.

**7. PERFORMING ORGANIZATION NAME(S) AND ADDRESS(ES)**

Indiana University  
Indianapolis, Indiana 46202-5167

*E-Mail:* stdwilli@iupui.edu

**8. PERFORMING ORGANIZATION REPORT NUMBER**

**9. SPONSORING / MONITORING AGENCY NAME(S) AND ADDRESS(ES)**

U.S. Army Medical Research and Materiel Command  
Fort Detrick, Maryland 21702-5012

**10. SPONSORING / MONITORING AGENCY REPORT NUMBER**

**11. SUPPLEMENTARY NOTES**

**12a. DISTRIBUTION / AVAILABILITY STATEMENT**

Approved for Public Release; Distribution Unlimited

**12b. DISTRIBUTION CODE**

**13. ABSTRACT (Maximum 200 Words)**

The objective of this proposal is to develop gene therapy strategies that inhibit ovarian cancer cell growth and selectively improve sensitivity of ovarian cancer cells to chemotherapy and radiation. The proposal focuses on in vitro and in vivo "proof-of-concept" studies of target discovery.

Four highly interactive projects make up this proposal. We have identified key genes that may be effective targets in ovarian cancer therapy. The first three projects seek to identify alterations in these genes which, either alone or in combination with chemotherapy or radiation, will efficiently kill ovarian cancer cells. Project 4 will identify promoters that allow for high expression of our key gene(s) in ovarian cancer cells but minimal expression in normal tissues.

**14. SUBJECT TERMS**

Cell cycle control, DNA repair, drug resistance, experimental chemotherapy, gene therapy, cDNA array, tissue specific promoters

**15. NUMBER OF PAGES**

64

**16. PRICE CODE**

**17. SECURITY CLASSIFICATION OF REPORT**

Unclassified

**18. SECURITY CLASSIFICATION OF THIS PAGE**

Unclassified

**19. SECURITY CLASSIFICATION OF ABSTRACT**

Unclassified

**20. LIMITATION OF ABSTRACT**

Unlimited

**Table of Contents**

<b>Cover.....</b>	<b>1</b>
<b>SF 298 .....</b>	<b>2</b>
<b>Table Of Contents .....</b>	<b>3</b>
<b>Introduction.....</b>	<b>4</b>
<b>Body.....</b>	<b>5-24</b>
<b>Key Research Accomplishments.....</b>	<b>24-25</b>
<b>Reportable Outcomes.....</b>	<b>25-26</b>
<b>Conclusions.....</b>	<b>26-27</b>
<b>References.....</b>	<b>27-29</b>
<b>Appendices.....</b>	<b>29</b>

## **INTRODUCTION**

The objective of this proposal is to develop gene therapy strategies that inhibit ovarian cancer cell growth and selectively improve sensitivity of ovarian cancer cells to chemotherapy and radiation. The proposal focuses on *in vitro* and *in vivo* "proof-of-concept" studies of target discovery.

Four highly interactive projects make up this proposal. We have identified key genes that may be effective targets in ovarian cancer therapy. The first three projects seek to identify alterations in these genes which, either alone or in combination with chemotherapy or radiation, will efficiently kill ovarian cancer cells. Project 4 will identify promoters that allow for high expression of our key gene(s) in ovarian cancer cells but minimal expression in normal tissues.

To increase sensitivity of ovarian cell lines to chemotherapy and radiation by genetic modification, Projects 1 and 2 will modify DNA repair pathways, and the most promising gene targets identified are being tested in tumor xenografts. Project 3 investigates the role of the cyclin dependent kinase inhibitors (CDKI's) in ovarian cancer cell cycle control and tests the hypothesis that sustained overexpression of p27<sup>kip1</sup> and p57<sup>kip2</sup> will suppress growth and/or cause programmed cell death in ovarian cancer cell lines. The effect of adding chemotherapy will be studied, and the most promising strategies from Project 3 will then be evaluated in xenografts by our animal core. In Project 4, human cDNA microarray technology is being used to identify ovarian cancer specific promoters that will allow effective expression of these altered genes in ovarian tumor cells but limited expression in normal cells.

## BODY

### ***Project 1: Therapeutic manipulation of the DNA base excision repair pathway for ovarian tumor sensitization (PI: Mark R. Kelley, Ph.D.)***

**Task 1. Identify altered Ape1 dominant-negative proteins that sensitize ovarian tumor cell lines to chemo-IR therapy (months 1-24). Mutants of Ape1, which bind substrate DNA with wild-type or better affinity but do not execute repair, will be expressed in ovarian (HeyC2 and SKOV-3X) cell lines using the ecdysone-inducible system (months 1-36). End points such as cell growth, cytotoxicity, DNA damage, and apoptosis will be assessed. Treatments to be used to monitor for improved cytotoxicity include methyl methanesulfonate (MMS), mafosfamide (clinical agent), and ionizing radiation (IR). (months 1-36)**

As discussed in our first year annual report, we have been focusing on the knock down of APE1 using RNAi (silencing RNA). SKOV-3X ovarian cancer cells

were treated with APE1-siRNA oligonucleotides and cultured for seven days. Aliquots of cells were used each day and APE1 protein level determined using Western blot analysis and APE1 monoclonal antibody. As shown in Figure 1, APE1 levels decline 90% three days after siRNA oligonucleotide addition and remain low for four days in SKOV-3X out to day 7. We have observed this pattern of decreased APE1 expression

in other cell ovarian cancer cell lines (unpublished data). The experiment was repeated, and at three days after APE1-siRNA treatment cells were collected and AP endonuclease assays performed. There is a clear loss of APE1 endonuclease activity following APE1-siRNA treatment (data not shown) showing a correlation between APE1 protein levels and AP endonuclease repair function.

***Figure 1. Ovarian cancer cell line SKOV-3X transfected with APE1 25 nM siRNA. Scrambled or "mouse" siAPE1 had no effect on APE1 levels.***

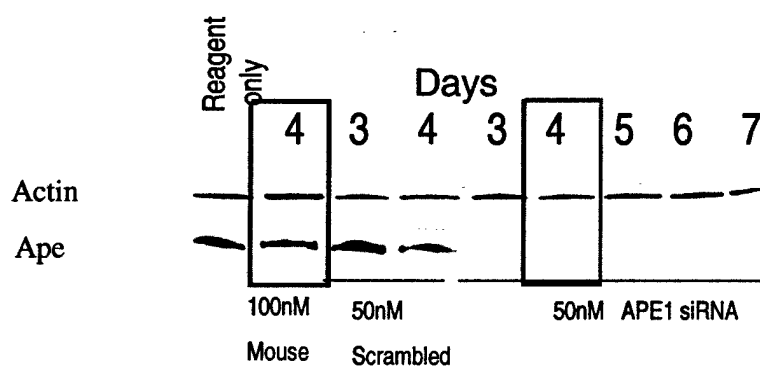

Following the initial characterization of APE1-siRNA knock-down methodology, we began a series of experiments to demonstrate that decreased APE1 levels leads to enhanced ovarian cancer cell sensitization to an alkylating agent, methyl methanesulfonate (MMS). SKOV-3X cells were treated with APE1-siRNA oligonucleotides and then these cells were treated with MMS and cell survival was assayed using the MTT assay. The results are shown in Figure 2. At the lower doses of MMS (less than 0.2 mM) there is a clear decrease in cell survival in the siAPE1 treated cells compared to the scrambled treated cells.

**Figure 2. SKOV-3X cells treated with the alkylating agent, MMS (MTT assay).**

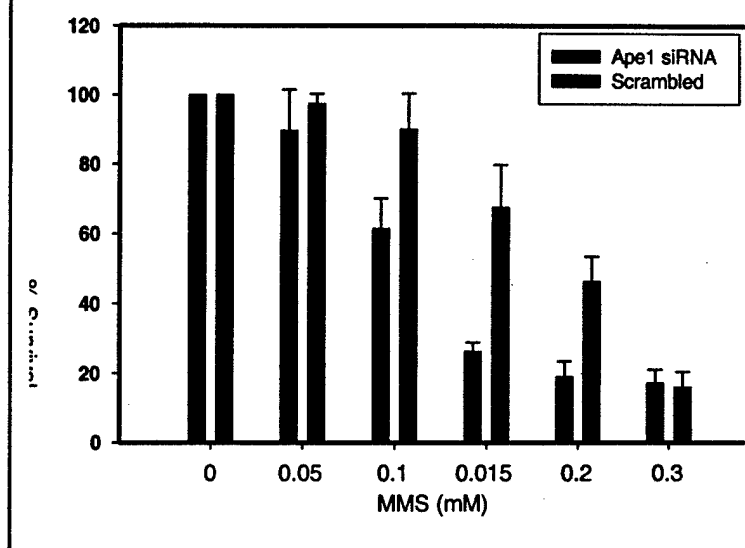

At the highest dose used, there is no discrimination due to treatment most likely due to the majority of cells, siAPE1 or scrambled treated dying.

**Task 2. Determine the effectiveness of MPG and MPG<sup>mutants</sup> overexpression at killing ovarian tumor cells following alkylating agent chemotherapy. We will make site directed mutations in the active site of MPG which should allow for binding to DNA lesions without removing damaged base. (months 1-12). The MPGs will be overexpressed in ovarian cell lines, and survival will be monitored following exposure to MMS, mafosfamide and cisplatin. (months 1-36)**

As stated in the last annual report, we have demonstrated that overexpression of MPG leads to cell killing in breast cancer cells and have confirmed these findings in ovarian cancer cells. We will continue these studies with more detailed studies on the mechanism involved and the use of the more relevant clinical agents mafosfamide and cisplatin.

**Task 3. Determine the effects of co-overexpression of Ape1<sup>mutants</sup>, MPG and MPG<sup>mutants</sup>.**

We will monitor whether combined expression enhances the ovarian tumor cell killing effect of lower doses of chemo-/IR agents administered alone or simultaneously. (months 12-36). Combined expression will be accomplished using either two independent expression plasmids or IRES (internal ribosome entry site) elements and the same expression construct, as well as an adenoviral expression vector. (months 12-36)

**Figure 3. Fusion Image of FDG Uptake with x-ray CT anatomy of an SC growing Ovarian tumor.** The uptake of FDG in the SKOV-3X tumor growing subcutaneously can be readily identified in the tumor. Also note the usual uptake of FDG in the bladder and liver. The area of high FDG accumulation below the acquired CT image is the injection site in the tail vein.

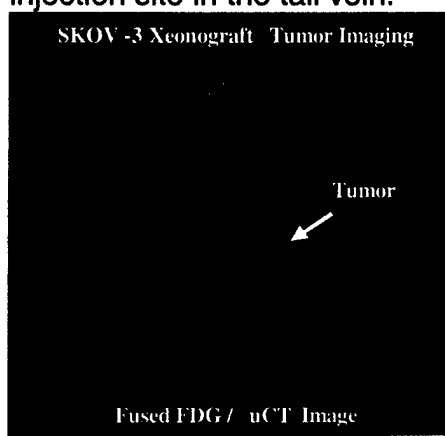

Co-expression studies are underway with some of the selected APE1 mutants from Task 1 and the MPG construct from Task 2.

**Task 4. Determine *in vivo* chemo- and IR-sensitivity of ovarian cells expressing Ape1<sup>mutants</sup>, MPG, or MPG<sup>mutants</sup>. (months 6-36). Ovarian cell lines carrying mutant Ape1, MPG, or MPG<sup>mutants</sup> genes will be used to produce tumors in the Xenograft Core A. (months 6-36). Dose-response studies will be performed on tumors produced from non-transfected and transfected cells to determine if the addition of the Ape1 mutants or MPG/MPG<sup>mutant</sup> gene product increases sensitivity to the drugs. (months 6-36). Sensitivity to mafosfamide, cisplatin, and IR will be tested. (months 6-36)**

These studies should begin immediately following the completion of Tasks 1 and 2. However, we have begun, with the imaging core to focus on developing non-invasive xenograft models to explore the results we find with APE1 siRNA in cell lines

for use in mice. To demonstrate the feasibility of imaging SKOV-3X tumor xenografts,  $1 \times 10^7$  SKOV-3X cells were subcutaneously injected into a site positioned dorsally, lateral to the backbone and approximately equidistant from the last rib and the hip in NOD/SCID mice. The tumor xenografts were allowed to grow for 4 weeks and FDG small animal PET (IndyPET II) and EVS microCT studies were performed. PET imaging data was acquired continuously for 1 hour following a tail vein injection of approximately 1 mCi of FDG. Following the FDG study, the animal holder was transferred to the EVS RS-9 microCT scanner and a 93 micron resolution scan was performed. Figure 3 shows the fusion of a PET FDG image with the corresponding anatomy from a CT image. This fused image clearly shows the increased FDG uptake in the xenograft tumor.

Caliper measurements were performed in each of the NOD/SCID mice on the day prior to PET and CT imaging. A comparison of caliper and image derived tumor volume estimates are shown in Figure 4.

A second pilot study was performed in the NOD/SCID SKOV-3X model to examine the feasibility of monitoring changes in FDG uptake produced by APE

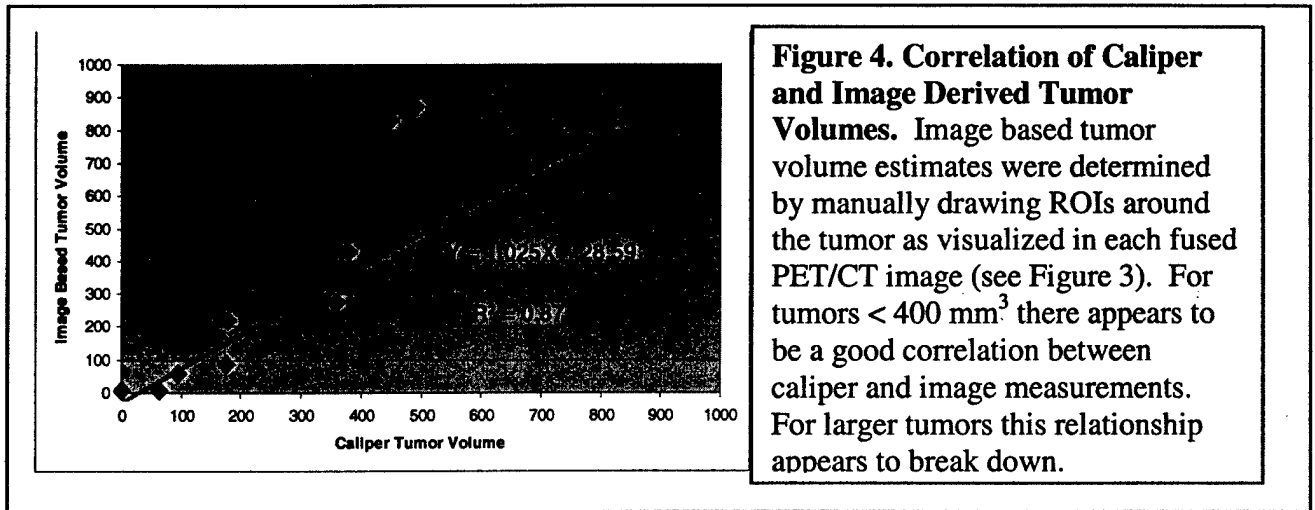

siRNA expression. Two groups of animals were studied using the imaging protocol previously described. In the first group (N=3) animals were injected with cells that transiently expressed APE siRNA. The second group (N=3) were injected with cells that transiently expressed nonsense siRNA to serve as a control group. The results from this study are shown in Figure 5. The tumors with transient expression of siRNA demonstrated a statistically significant reduction in FDG uptake relative to the control group at 3 weeks. At 6 weeks this difference was not significantly different consistent with the duration of the transient expression of siRNA.

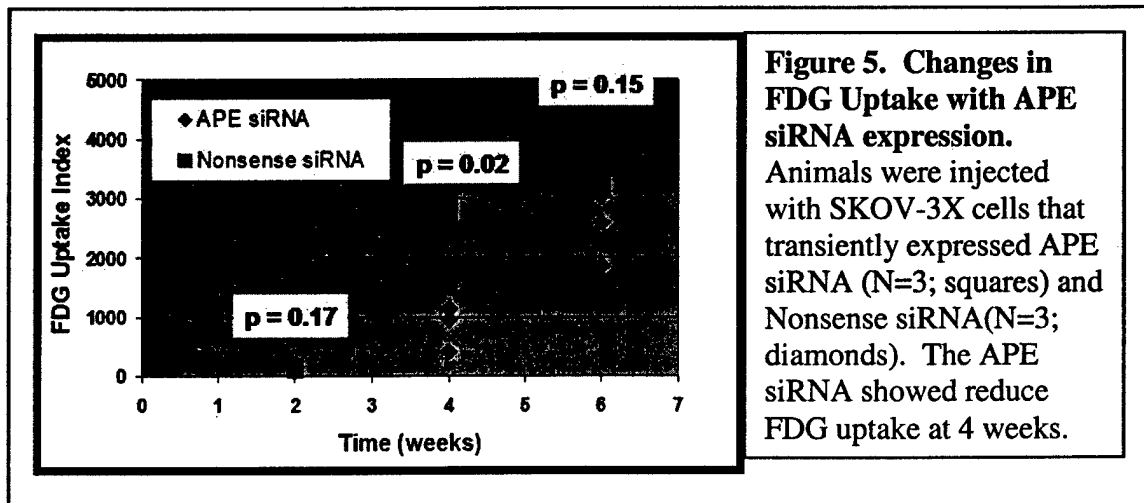

**Project 2: Targeted inhibition of a key DNA repair enzyme, DNA-dependent protein kinase, in ovarian cancer co-therapy (PI: S-H. Lee, Ph.D.)**

**Task 1. To develop a peptide that specifically inhibits DNA-PK kinase activity by interfering with the interaction of DNA-PK catalytic subunit (DNA-PKcs) and Ku70/Ku80**

1.1. Screening for candidate peptides that interact with N-terminal domains of Ku70-Ku80  
Studies from us and others indicated that DNA-PKcs interacting domain is localized at the extreme C-terminus of Ku80 (amino acids 720-732) (Gell and Jackson, 1999; Kim & Lee, unpublished). Since the C-terminus of Ku80 is also likely involved in heterodimer assembly and DNA termini binding, this region (amino acids 720-732 of Ku80) was selected to synthesize a target peptide that would prevent DNA-PKcs from binding to Ku70/Ku80 regulatory subunits. To deliver a peptide to the cancer cells, a cell-permeable peptide import domain and the nuclear localization domain were added to the target peptide to obviate the need for permeabilization or microinjection of individual cells (Kim *et al*, 2002).

We selected a target peptide representing amino acids 720-732 of Ku80. This domain not only interacts with DNA-PKcs, but may also be involved in Ku heterodimer assembly and DNA termini binding. Peptide-based inhibitor also contains a hydrophobic signal peptide, so-called membrane-translocating carrier, which not only facilitates secretion of protein, but also is important for importing synthetic peptide into cell (Lin YZ *et al*, 1995). We therefore synthesized a 38-residue peptide (HNI-38) comprising the signal peptide sequence (AAVALLPAVLLALLAP), nuclear localization signal NLS (VQRKRQKLM), followed by a tyrosine (Y) residue, and 12-residue of peptide inhibitor sequence (EGGDVDDLLDMI) representing the C-terminus of Ku80 (amino acids #721-732).

**1.2. Effect of target peptide on the functions of DNA-PK and/or Ku70/Ku80**

The target peptide (HNI-38) inhibited the interaction of DNA-PKcs with Ku70/Ku80 and the binding of Ku complex to duplex DNA. DNA-PKcs and Ku70/Ku80 are abundant proteins approximately  $5 \times 10^5$  molecules per human cells (Lee and Kim, 2002) and most of Ku70/Ku80 heterodimer exists in cell extracts without forming a complex with DNA-PKcs in the absence of DNA (Hammarsten and Chu, 1998). Target peptide (HNI-38) was examined for its effect on the interaction between DNA-PKcs and Ku70/Ku80 in the presence of dsDNA. Although it was marginal, the addition of increasing amount of target peptide (HNI-38) not the control peptide (HN-26) led to a decrease in DNA-PKcs associated with dsDNA (Kim *et al*, 2002). We also carried out a dsDNA pulldown assay to examine the effect of HNI-38 on Ku's DNA binding activity. Target peptide (HNI-38) significantly interfered with binding of Ku complex to dsDNA under the conditions where control peptide (HN-26) showed virtually no effect (Kim *et al*, 2002). This result suggests that target peptide not only affects the interaction between DNA-PKcs and Ku, but also interferes with the Ku's DNA binding activity.

Efficacy of target peptide was also analyzed for DNA-PK kinase activity *in vitro*. DNA-PK kinase activity was inhibited up to 50% in the presence of target peptide under the condition where a control peptide showed minimal effect (Kim *et al*, 2002), which strongly supported a notion that target peptide binds to DNA-PKs and interferes with the interaction between DNA-PKs and the Ku complex.

**Task 2. To determine if a peptide-based inhibitor of DNA-PK (or negative-dominant mutant of Ku80) lowers anti-cancer drug resistance and facilitate killing of ovarian cancer cells**

**2.1. *In vivo* expression system**

To deliver a specific inhibitor (or mutant protein) to the nucleus of ovarian cancer cells, Ku80 containing EGFP at the C-terminus was cloned into an adenoviral vector (Ad5CMV) expression system (Figure 1). A control containing only GFP showed ubiquitous expression, while Ku80 was localized in the nucleus. This adenoviral vector will be used to express a negative-dominant mutant of Ku80 that can interfere with the *in vivo* function of Ku80.

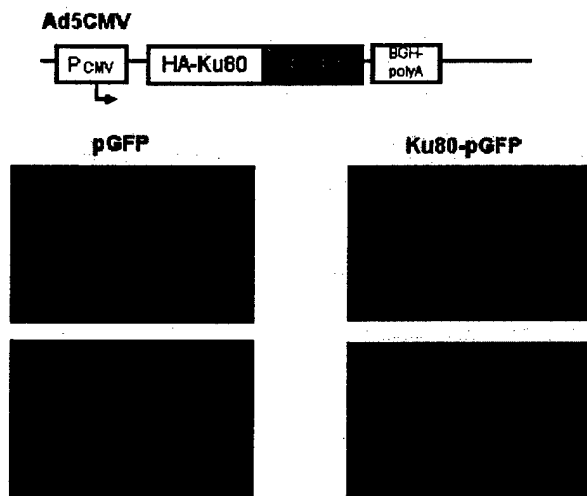

**Figure 1.** Expression of GFP (left panels) or hemagglutinin (HA)-tagged Ku80-pGFP (right panels) in ovarian cancer cells (Hey).

A series of Ku80 deletion mutants are being generated and will be tested for their negative dominant phenotype in inhibiting cancer cell growth after cloning them into adenoviral vector (Ad5CMV vector; Figure 2, below). Once prepared, these mutants will be examined for their effect on cancer cell growth.

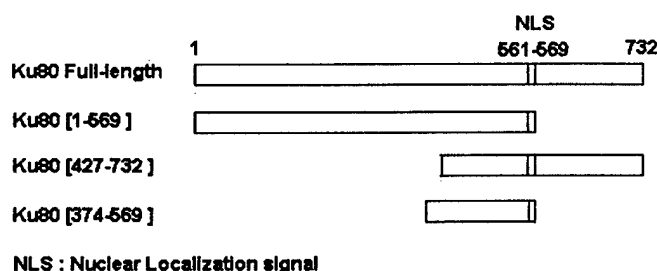

## 2.2. Effect of a peptide-based inhibitor in chemotherapy drug or IR therapy in ovarian cancer cells

Cells lacking DNA-PK catalytic subunit showed increased sensitivity to DNA damaging drugs or IR (Lees-Miller et al., 1995; Kirchgessner et al., 1995), suggesting that DNA-PK activity is essential for DNA repair and cell survival upon DNA damage. We therefore tested whether a targeted inhibition of DNA-PK by a peptide HNI-38 would sensitize ovarian cancer cells upon treatment of ionizing radiation or chemotherapeutic drug (cisplatin). Two ovarian cancer cells (Hey and Hey-C2) were treated with either control (HI-26) or target peptide (HNI-38) and tested for the efficacy of DNA-PK inhibitory peptide on lowering resistance of cells in response to ionizing radiation using standard colony count cell survival assay. Both control and target peptides did not show any effect on cell growth in the absence of ionizing radiation. However, cells treated with IR showed significant cell growth inhibition in the presence of target peptide but not with control peptide (Kim *et al*, 2002), suggesting that cell growth inhibition by target peptide occurs through targeting DNA-PK activity. Cells treated with cisplatin, although not as effective as those treated with IR, also showed inhibitory effect on cell growth in the presence of HNI-38 (Kim *et al*, 2002).

## 2.3. *In vivo* efficacy of chemotherapy drug (doxorubicin or cisplatin) or IR therapy on shrinkage of mouse xenograft tumor

The xenograft model is an *in vivo* tool to examine the efficacy of a mutant Ku80 in drug resistance of ovarian cancers. Once we select Ku80-mutant from the cell survival study, the mutant will be tested in shrinkage of mouse xenograft tumor. A drug-resistant ovarian cancer cells (SKOV3X) will be transfected with the pVgRXR plasmid and the pIND containing a mutant Ku80 gene. Transfected cells will be injected at two subcutaneous sites on athymic mice ( $1.0 \times 10^7$  cells/ mouse). After a suitable time for establishment of tumors, the animals will be treated with chemotherapeutic drug (adriamycin or cisplatin) and the resultant tumor mass will be assessed during an additional growth period. The subcutaneous site will serve as a convenient, visible site for monitoring of tumor growth. The mouse will also receive an intraperitoneal injection of cells ( $1.0 \times 10^6$  cells/mouse) to form orthotopic tumors. Throughout the experimental treatment period, the volume of the subcutaneous tumor will be estimated by measuring its length, breadth and depth with a set of calipers. Animals will be treated with drug twice per week for 3 weeks and tumor growth will be followed for another 3 weeks. At

the end of the experiment, tumor (both subcutaneous and intraperitoneal) will be excised and weighed.

**NOD/SCID mouse ovarian cancer model:**

The system we will use is a human ovarian cancer in the NOD/SCID mouse xenograft model. Six-to-eight-week-old NOD/SCID mice will be anesthetized with methoxyflurane. Following anesthesia, a small subcutaneous incision will be made in the abdomen, and  $10^6$  ovarian cancer cells will be injected. Subsequent studies after the baseline assessments of implants of SKOV3X cells have been made will involve implantation of cells resulting from Aim 3 and evaluation of tumors developing in mice. *In vivo* correlation will provide valuable information regarding the effects on the intact animal of the specific modifications in the ovarian cancer cells. Thus, we should be able to determine the effects of a mutant Ku80 on the growth and progression of ovarian cancers *in vivo*. This obviously leads to the potential for translation of these findings to women with ovarian cancer.

***In vivo* tumor volume assessment: Positron emission tomography (PET)**

Imaging analysis has obvious advantage over direct tumor volume measurement since it can monitor tumor shrinkage over time without sacrificing mice. FdG or  $^{11}\text{C}$ -choline will be used as a tracer for tumor in imaging analysis under guidance of Dr. Gary Hutchins (Director, PET Imaging Facility, IUSM).

In summation, DNA-PK/Ku70-80 complex is essential for DNA repair as well as cell cycle arrest in response to DNA damage, which contributes to cell survival by protecting cells from apoptosis. Cells treated with target peptide not control peptide showed a noticeable decrease in dsb repair following high dose of IR, suggesting that HNI-38 specifically targets DNA-PK *in vivo* and interferes with dsb repair activity through inhibition of DNA-PK activity. Targeted inhibition of DNA-PK by HNI-38 also caused cell growth inhibition only when cells were treated with IR, suggesting that HNI-38 targeted DNA-PK and lowered resistance of cells in response to IR, which eventually causes growth inhibition of both ovarian cancer cells. Treatment of cells with HNI-38 also showed additive effect on cell growth inhibition in response to cisplatin treatment. This observation is in keeping with previous findings that DNA-PK is directly involved in NER action in mammals (Muller et al., 1998). It also supports a notion that a targeted inhibition of DNA-PK would sensitize cancer cells upon treatment of chemotherapeutic drugs such as cisplatin. Together, our study described here not only validates DNA-PK as a useful molecular target for the treatment of drug-resistant cancer cells, but also supports physiologic role for DNA-PK in IR or chemotherapy drug resistance of cancer cells.

**Project 3: DNA repair and cell cycle therapeutic targets for ovarian cancer  
(PI: Maureen Harrington Ph.D.)**

**Task 1: Mutations will be generated in the *KIP2* gene at amino acid residues in common with p27<sup>Kip1</sup> protein that are known to control p27<sup>Kip1</sup> protein stability. Using the p57<sup>Kip2</sup> mutants, we will determine if the mutations affect p57<sup>Kip2</sup> protein stability, subcellular location and/or function in normal and in tumor derived ovarian epithelial cell lines.**

- **Site-directed mutagenesis of the p57<sup>Kip2</sup> gene, subcloning of the cDNAs encoding wild-type and mutant *KIP2* into mammalian expression vectors (months 0-6).**

This step was completed during year 1; the p57<sup>Kip2</sup> mutant was generated and cloned into pcDNA3.1(-)/Myc-His (Invitrogen Corp., San Diego, CA), a mammalian expression vector.

- **Introduction of mammalian expression vectors into non-tumorigenic immortalized ovarian surface epithelial cell line (IOSE) and into epithelial ovarian cancer cell lines (HeyC2 and SKOV3X) (months 6-12).**

This step was completed during year 1; the vectors have successfully expressed wild-type and mutant p27<sup>Kip1</sup> and p57<sup>Kip2</sup> proteins.

- **Comparison of wild-type and mutant p57<sup>Kip2</sup> protein activity, stability and subcellular location by western blotting and CDK2 kinase assays (months 6-12).**

During year 1 we determined that the subcellular location of the wild-type and mutant p57<sup>Kip2</sup> was nuclear. We also found that the mutated p57<sup>Kip2</sup> (T342A) does not stabilize the protein.

Year 2: Our goal was to determine whether wild-type and mutant p57<sup>Kip2</sup> are both mechanistically functioning as CDKIs.

Methodology: HeyC2 cells were transfected with the empty expression vector, pcDNA 3.1/myc-His or the expression vector containing the cDNA for the wild-type or mutant p57<sup>Kip2</sup>. For these studies, Fugene 6 (Roche, Indianapolis, IN) was used as the transfection agent. Twenty-four hours after transfection, the cells were lysed and the cellular protein extract was immunoprecipitated using an anti-c-myc antibody. The immunoprecipitated proteins were subjected to Western blot analysis using anti-p57<sup>Kip2</sup> or anti-CDK2 antibodies as probes (Fig. 1). Results indicate that, as expected, wild-type and mutant p57<sup>Kip2</sup> proteins were immunoprecipitated using the anti-myc antibody (due to the myc tag derived from the cloning vector). CDK2 was

coimmunoprecipitated with both the wild-type and mutant p57<sup>Kip2</sup> proteins. However, a greater amount of CDK2 was associated with the wild-type p57<sup>Kip2</sup> when compared to the level of CDK2 coimmunoprecipitated with the mutant p57<sup>Kip2</sup>.

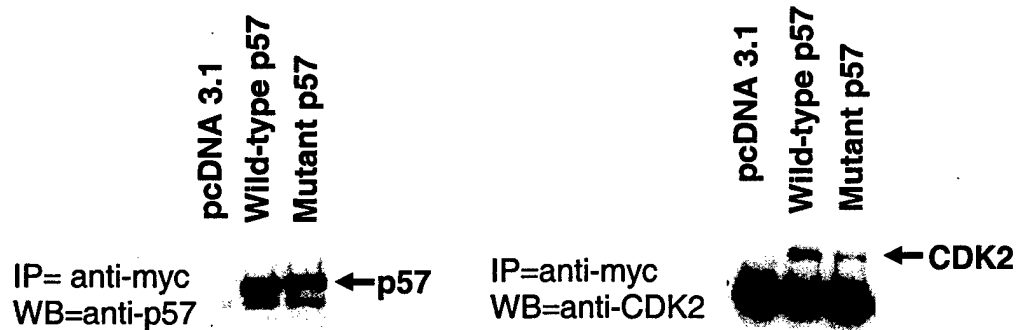

**FIGURE 1: CDK2 coimmunoprecipitated with wild-type and mutant p57<sup>Kip2</sup>.**

**Task 2: To determine if transduction of stabilized forms of p27<sup>Kip1</sup> and/or mutated p57<sup>Kip2</sup> inhibit the growth of epithelial ovarian cancer cell lines grown *in vitro* and as xenografts in nude mice.**

- **Subcloning of cDNAs encoding wild-type p27<sup>Kip1</sup> and p27<sup>Kip1/T187A</sup> (encodes the stabilized p27<sup>Kip1</sup> protein) into inducible mammalian expression vectors. Generation of stable epithelial ovarian cancer cell lines (HeyC2 and SKOV3X) containing these cDNA under the control of an ecdysone-inducible promoter (months 12-15).**

The results from the studies conducted during year 1 indicated that we could not use an inducible system to express the p27<sup>Kip1</sup> protein in cells.

During year 2, our new strategy for developing an expression system is to use folate to target expression vectors to the folate receptors on ovarian cancer cells.

**Methodology:** We are investigating folate delivery systems to transfect a reporter gene to ovarian tumor cell lines. The system described here uses a folate-PEG-poly-L-lysine complex to deliver pEGFP<sub>luc</sub> (Clontech, Palo Alto, CA), a green fluorescent protein/luciferase reporter plasmid. This complex uses poly (ethylene glycol) (PEG) as a molecular spacer. At one end of the PEG is a molecule of folate, while the other end of the PEG is attached to a poly-L-lysine backbone. The poly-L-lysine functions to condense plasmid DNA by electrostatic interactions. In this experiment SKOV3X and HeyC2 cells were cultured in 12 well plates. The cells were transfected with 4  $\mu$ g

pEGFPluc contained within folate-PEG-poly-L-lysine complexes. After 24 hours, the cells were subjected to a luciferase assay to detect the expression of the luciferase reporter gene. The results show that the folate-PEG-poly-L-lysine was able to transfect both the SKOV3X and HeyC2 cell lines (Table 1). It should be noted that the HeyC2 cells showed a higher level of luciferase expression when transfected by the folate-PEG-poly-L-lysine than when transfected with the commercial liposomal reagent, Fugene 6. Thus, the folate receptor may be a useful target for tumor-specific drug delivery. We are currently studying folate conjugated to liposomes as further advancement for the delivery of plasmid DNA to ovarian cancer tumor cells.

**TABLE 1: LUCIFERASE REPORTER GENE EXPRESSION AFTER TRANSFECTION BY FOLATE-PEG-POLY-L-LYSINE COMPLEX**

SKOV3X Cells	Relative Light Units
pEGFPluc only	127
pEGFPluc: folate/PEG/poly-lysine	76,489
pEGFPluc: Fugene 6	399,580
HeyC2 Cells	Relative Light Units
pEGFPluc only	141
pEGFPluc: folate/PEG/poly-lysine	82,425
pEGFPluc: Fugene 6	8,592

- **Growth assays will be performed to determine if cell growth is inhibited and apoptosis is induced in an ecdysone regulated manner (months 15-24).**

As mentioned above, an ecdysone regulated system is not feasible for our studies. In year 2 we used colony assays as an alternative method to determine if the expression of CDKIs will inhibit the growth of epithelial ovarian cancer cells.

Methodology: Cells were transfected with either pcDNA3.1, wild-type p27<sup>Kip1</sup>, p27<sup>Kip1/T187A</sup>, wild-type p57<sup>Kip2</sup> or mutated p57<sup>Kip2</sup>, using Fugene 6 as the transfection agent. Twenty-four hours after transfection, the cells were harvested by trypsinization and replated, in triplicate, at a density of 300 cells/60 mm culture dish, in the presence of Geneticin (G418) to eliminate nontransfected cells. Twenty-four hours later, the Geneticin containing media

was removed and replaced with media without Geneticin. The cultures were allowed to grow for 12 days. Then, the resulting colonies were fixed, stained and counted. The results from these assays show that the most efficient and consistent inhibitor of tumor cell growth is p27<sup>Kip1/T187A</sup> (Fig. 2).

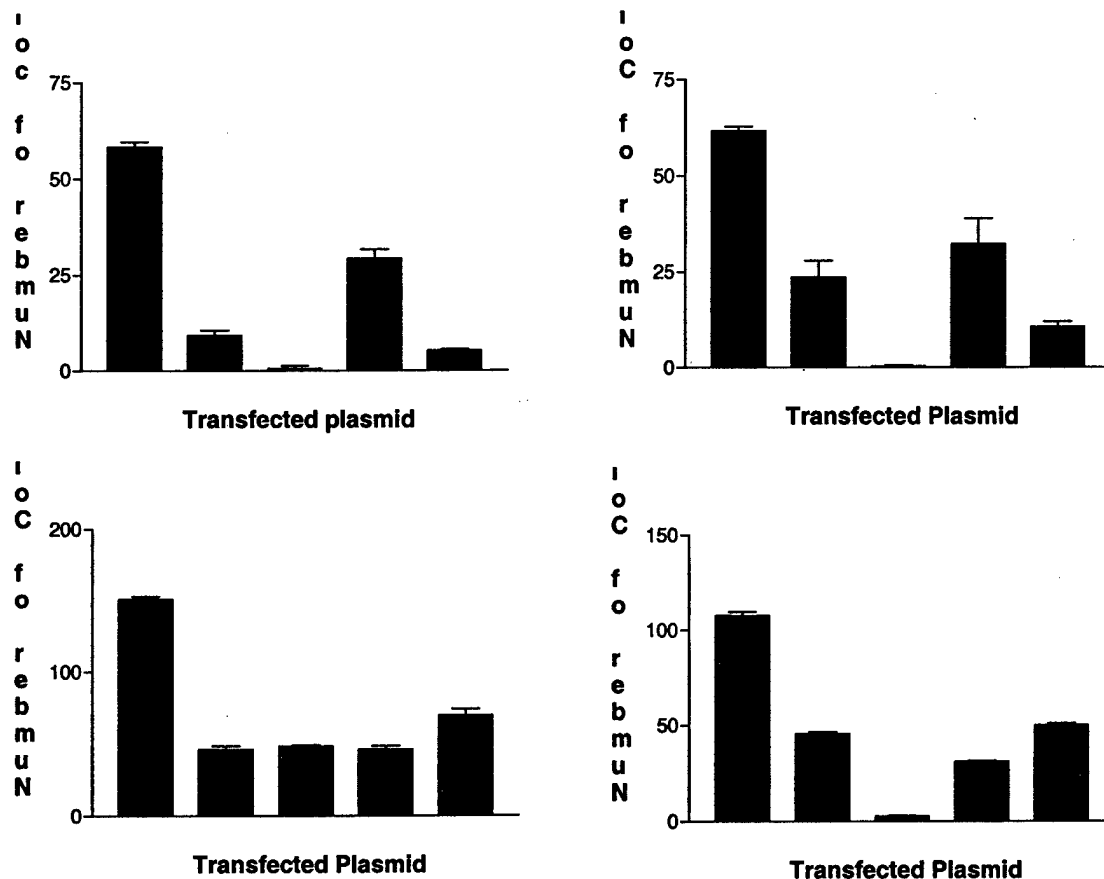

**FIGURE 2: COLONY ASSAYS SHOWING THE INHIBITION OF TUMOR CELL GROWTH BY WILD-TYPE AND MUTANT p27 AND p57.**

• ***In vivo* growth assays using xenograft nude mouse model.** Cell lines expressing wild-type and mutant *KIP1*, and potentially *KIP2* in an ecdysone regulated manner will be introduced into animals. We will determine if the growth of the introduced tumor cells is modulated in an ecdysone regulated manner. These studies will be performed by Core A.

Because we have determined that the ecdysone system is not suitable for this study, we plan to further develop the folate-receptor targeting strategy in the ensuing grant year. We will be investigating whether folate can be used to target the expression of p27<sup>Kip1</sup> protein to ovarian cancer cells *in vivo*.

During year 2 of this grant we have started to develop an *in vivo* bioluminescence method to detect ovarian tumors in the nude mouse model. This has been done in collaboration with Core A.

**Methodology:** The HeyC2 cell line has been stably transfected with pGL3 (Promega, Madison, WI), a luciferase reporter vector, creating the cell line termed HeyC2-luc. Female nude mice were inoculated with either  $5.5 \times 10^6$  HeyC2-luc cells subcutaneously (s.c.) or intraperitoneally (i.p.) with  $3.0 \times 10^5$  HeyC2-luc cells. Nine days after tumor implantation, the mice were anesthetized and given an i.p. injection of luciferin (the substrate for luciferase). The animals were then imaged with a NIGHTOWL Molecular Light Imager (Berthold Technologies, Oak Ridge, TN). This imaging system can detect photons of light emitted from the luciferase-luciferin enzymatic reaction within the tumor cells implanted in the mice. Because photons of light can pass through the skin and other tissues of the animal, the mice do not require any surgery to visualize tumors and can be imaged many times during the course of tumor development. Results from animals imaged nine days post tumor implantation are shown (Fig. 3). Most significant is the fact that the intraperitoneal tumors were readily detectable by *in vivo* bioluminescence, yet they were undetectable by standard methods of external gross examination and palpation.

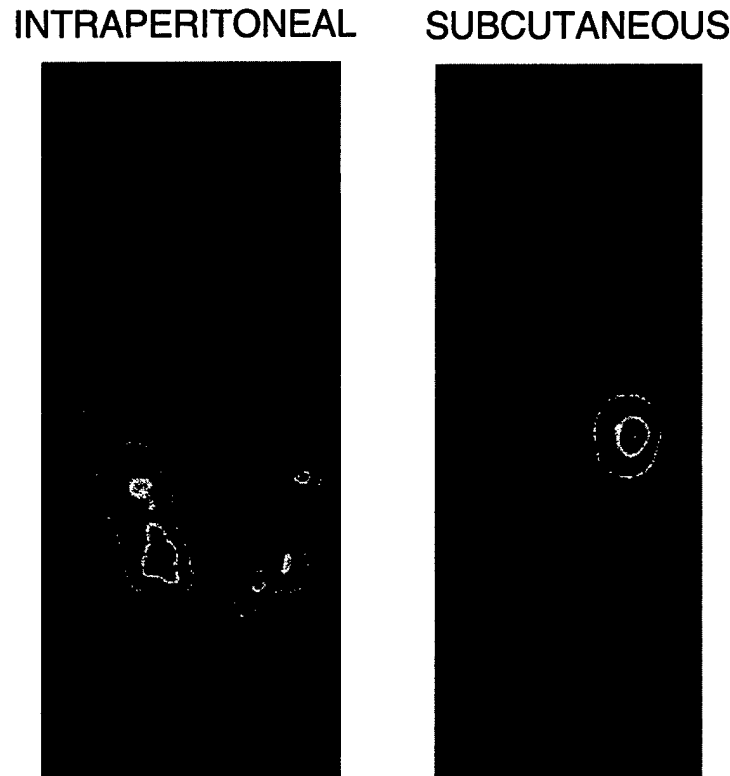

**FIGURE 3: IN VIVO BIOLUMINESCENCE IMAGING OF NUDE MICE IMPLANTED WITH LUCIFERASE-EXPRESSING TUMOR CELLS**

**Task 3: To determine if treatment of cells that express stabilized forms of p27<sup>Kip1</sup> and/or mutated p53<sup>Kip2</sup> with taxanes and /or platins increase epithelial ovarian cancer cell death *in vitro* and in cells grown as xenografts in nude mice.**

- Cell growth assays will be performed with cells stably expressing wild-type and/or mutant *KIP1* and/or *KIP2* in an ecdysone regulated manner, in the presence of chemotherapeutic agents studied in Projects 1 and 2 as well as the taxanes and platins to be studied in this project to determine if a higher degree of cell death is achieved (months 24-36).
- Growth assays using xenograft nude mouse model. Cell lines expressing wild-type and mutant *KIP1*, and potentially *KIP2* in an ecdysone regulated manner will be introduced into animals. We will determine if death of the introduced tumor cells is enhanced when chemotherapeutic agents are administered during the induction of wild-type and/or mutant *KIP1* and/or *KIP2*. These studies will be performed by Core A (months 24-36).

The studies described in Task 3 will begin in year 3 of this grant.

**Project 4: Identification of Ovarian Tumor-Specific Promoters (PI: Ken Nephew, Ph.D.)**

**Task 1: Identify highly expressed cDNAs in ovarian cancer.** Promoters of genes frequently upregulated in ovarian cancer may provide a means to direct expression of a therapeutic gene specifically in ovarian cancer cells. We accomplished Task 1 by performing extensive data mining of the of several studies (1-7) and categorizing genes that were known to be over-expressed in ovarian tumors. A small whey-acidic secretory (WAP) protein called HE4 has recently been shown to be overexpressed in ovarian cancer [1-7]. The potential use of HE4 as a biomarker for ovarian cancer has recently been described [8, 9]. Upregulation of HE4 in ovarian cancer appears to be due to a transcriptional event [10]. We concluded that the HE4 gene is over-expressed approximately ten-fold in early and late stage ovarian cancer and proceeded to isolate the HE4 promoter. In addition to HE4, we selected two other gene promoters, OSP-1 (11-13) and hTERT (14-16) and assessed their activity in ovarian and other cancer cells and normal cells.

**Task 2: Obtain the promoter region of candidate genes.** The HE4 promoter had not yet been described in the literature or data bases and fell into our previously defined category of being an unknown or uncharacterized promoter. We isolated the HE4 promoter and compared its activity in ovarian cancer cells with the activity of two established cancer gene promoters, hTERT and OSP-1

promoters, which had been described in the literature (11-16). We obtained hTERT and OSP-1 constructs from the corresponding laboratories. To isolate the HE4 promoter, A BAC clone (GenBank Accession # AL031663)

containing the full length HE4 gene was purchased from BACPAC Resources (Children's Hospital Oakland Research Institute, Oakland, CA) and analyzed using the Genomatix promoter prediction program CHIP2 (<http://www.genomatix.de>). A 2071bp fragment surrounding the putative promoter region was amplified. The size of the PCR product was verified and digested using convenient restriction sites to isolate four promoter regions, pHE4-1308, -799, -652, and -395 (Figure 1, above). Promoter fragments were ligated into the pGL-2-Basic vector (Promega) for transient transfection assays. The negative control construct, TATA-luc, was created by placing the

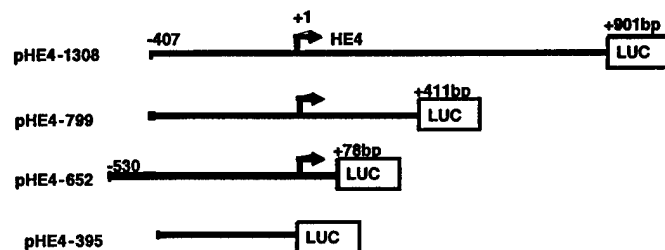

Figure 1. HE4 promoter constructs

minimal mPTHrP TATA promoter sequence (46 bases upstream from the transcription start site and 50 bases of a non translated exon) upstream of luciferase in the multiple cloning site of pGL2-Basic. The positive control vector, pGL2-Control (Promega), uses the SV40 promoter and enhancer to drive high expression of luciferase. The pHE4-652, *hTERT*, and OSP1 promoters were aligned using using T-Coffee (<http://www.ch.embnet.org/software/TCoffee.html>) and a sequence comparison was made using the Needleman-Wunsch global alignment program (<http://sunflower.bio.indiana.edu/bioweb/seqanal/interfaces/needle.html>).

**Task3: Identify the most specific and active promoter.** Initial testing of HE4 promoter fragments for activity was carried out using optimized HE4 promoter fragment constructs in transient transfection assays of HeLa cervical cancer cells and three ovarian cancer cell lines (SKOV-3, OVCAR-3, and A2780). At all concentrations of the four HE4 constructs tested (200-1000ng/well), minimal activity was observed in HeLa cells, and activity of HE4-395, -799, and -1308 was low in SKOV-3, OVCAR-3 and A2780 cells. In contrast, activity of pHE4-652 was observed in all three ovarian cancer cell lines. Therefore, pHE4-652 was chosen for use in subsequent experiments. Further optimization experiments were performed to ensure highest luciferase values for pHE4-652, *hTERT*, and OSP1 in each cell line and presented it the table below (detailed information can be found in the manuscript included in the appendix).

#### Optimization of Promoter Constructs in Cell Lines

Cell Line	pHE4-652	<i>hTERT</i> P-444	OSP-1
A2780	800	800	600
A2780CP	800	800	600
CP70	500	800	1000
HeyC2	400	500	300
SKOV3 & 3X	600	800	800
OVCAR-3	500	700	1000
NPA	300	1000	1000
MCF7	1000	1000	1000
nOSE/IOSE	1000	1000	1000
NHF/NHK	1000	1000	1000

The activity of the pHE4-652, *hTERT*-P444, OSP1 promoters was compared in epithelial ovarian cancer cell lines, non-ovarian cancer cell lines, and normal cell lines. The level of promoter activity was expressed as a percentage of the activity detected with a luciferase cDNA under the control of the SV40 promoter and enhancer region; independent of the promoter under analysis, all transfections were normalized against a cotransfected CMV- $\beta$ gal. Activity of pHE4-652 was greater than TATA-driven luciferase in all ovarian cancer cell lines except HeyC2 cells (experimental details can be found in the manuscript included in the appendix).

The level of pHE4-652 activity was highest in CP70, A2780, A2780CP, and SKOV-3x (20, 31, 82, and 318%, respectively; Figure below). Minimal activity of pHE4-652 was observed in MCF7, NPA, HeLa, nOSE, IOSE and primary fibroblasts (See Figure 4B in the manuscript in the appendix). We concluded that HE4 gene promoter drives luciferase expression specifically in epithelial ovarian cancer cells.

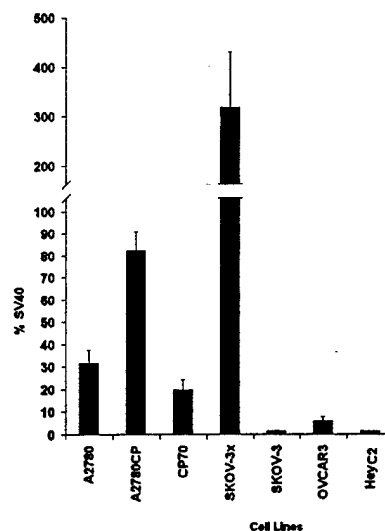

***pHE4-652 is active in ovarian cancer cell lines (above):*** Ovarian cancer cell lines were transfected with optimized ng/well pHE4-652 DNA. CMV- $\beta$ gal was cotransfected to control for transfection efficiency. Luciferase activity in each plasmid is given as a percentage of SV40 driven positive control plasmid pGL2-control. TATA-luc was used as a negative control. Values are represented as a percentage of SV40 promoter plus enhancer driven luciferase activity, and SV40 is normalized to 100%. Results represent the mean of at least three independent experiments. Error bars are  $\pm$ SEM.

To determine if the activity of pHE4 promoter was comparable to that detected for other gene promoters currently undergoing study, we examined the activity of candidate ovarian cancer gene therapy promoters OSP1 and *hTERT*. OSP1 activity was seen in ovarian cancer cell lines SKOV-3X, A2780, A2780CP and CP70 (see figure 5A in manuscript in appendix). However, OSP1 activity was seen in several non-ovarian tumor lines and normal cells, ranging from 9% in MCF7 breast cancer cells to 70% in normal

human keratinocytes (NHK) (Figure below and see Figure 5B in the manuscript in appendix).

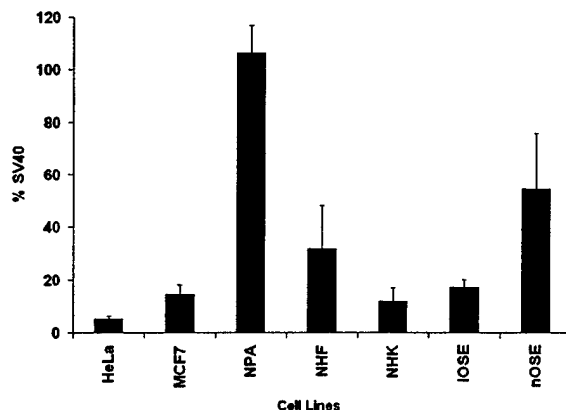

***OSP1 exhibits activity in non-ovarian cancer lines as well as normal ovary(above);*** OSP1 has considerable activity in the non-ovarian cancer cell line NPA (31% SV40) as well as NHF and NHK (51 and 70% SV40). Moderate activity of OSP1 was observed in normal and immortalized ovarian cell lines nOSE and IOSE (36 and 27% SV40 respectively).

The *hTERT* promoter was active in the majority of ovarian cancer cell lines (see Figure 6A in manuscript in appendix), and *hTERT* showed variable activity in the non-ovarian cancer cell lines, (Figure below and see Figure 6B in the manuscript in appendix).

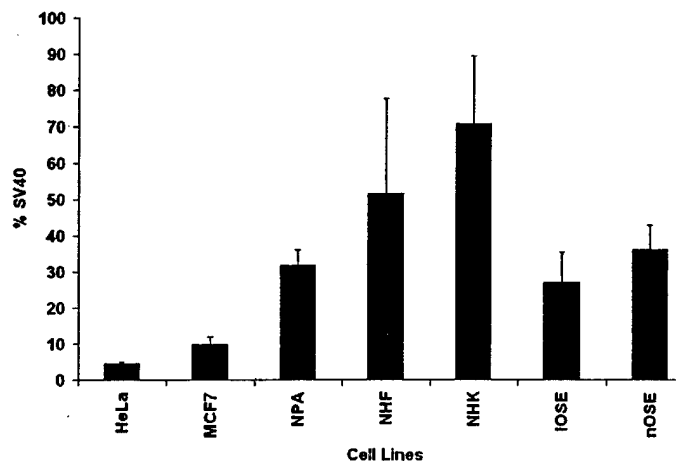

***hTERT is active in non-ovarian tumor lines and normal cell lines (above).*** Non-ovarian and normal cells were transfected with optimized *hTERT*-P444 DNA (ng/well). Values are represented as a percentage of SV40 promoter plus enhancer driven luciferase activity, and SV40 is normalized to 100%. Results represent the mean of at least three independent experiments. Error bars are  $\pm$ SEM.

In addition, we examined the HE4 promoter sequence for potential regulatory motifs and identified, at the sequence level, well-known transcriptional

elements such as AP1, AP2, and AP4 response elements throughout the promoter region (see details in manuscript in appendix and Figure 1B).

In conclusion, the HE4 promoter drives ovarian cancer specific expression of a reporter gene and deserves consideration for use in ovarian cancer gene therapy.

### ***Core A: Animal Models***

The original SOW indicated two tasks for year one.

#### ***Task 1: Establish parameters for in vivo induction of gene expression.***

Although it was originally proposed to use an ecdysone-inducible promoter to drive expression of the mutant target genes, it was found that another system, the tetracycline controlled promoter worked well in culture. Since the tet-on system would be much more economical, it was decided that this would be the used throughout. Three attempts to grow cells expressing an inducible form of mutated APE have failed. Cells stably transfected with empty vector did grow. Apparently, control of expression of the mutant APE did not allow for null expression in the absence of an exogenous stimulator. Because we were unable to get a clean negative control, the idea of using inducible expression vectors has been scrapped

***Task 2: Establish tumor lines from engineered HeyC2 and Skov 3X tumor cell sublines supplied from Projects 1-4.*** As these sublines have not been established in the other projects, we have not been able to begin to make tumor lines.

In lieu of engineered sublines to use in generation-of tumor lines, we have focused on establishing procedures required by the Animal Models core and developing the necessary baseline data on therapeutic responses of parent cell lines. This baseline data will be necessary for comparison in experiments using the engineered sublines.

Baseline X-irradiation experiments using grafted SKOV3x cells were performed and reported in the last annual report. Similar baseline studies have been performed with Hey C2 cells. These preliminary experiments allowed us to develop the system for X-irradiation and to define the dose range for experimental tests in engineered cells.

We are attempting to develop a system to follow intraperitoneal tumor growth. We have applied micro-PET with  $^{18}\text{F}$ -UDG as a tracer and micro-CT using an In Vivo Imaging Core facility of the IU Cancer Center. These techniques allow us to visualize the intraperitoneal tumors; we are in the process of defining the quantitative procedures that will allow us to follow the growth of a tumor. Recently, the In Vivo Imaging Core has acquired the capability to image tumors expressing luciferase. Ovarian cancer cell lines,

SKOV3x and HeyC2 were stably transfected with a luciferase reporter gene and these were injected subcutaneously and intraperitoneally. Both sc and ip tumors were imaged after 1 week of growth; this technique promises to be useful in following tumors during experimental therapies.

A new strategy has been followed in Project 1 in which APE expression is reduced by application of siRNA technology. Using this technology we will determine if cells expressing no or little APE mRNA are more susceptible to radiation of chemotherapy. When SKOV3x cells were transfected with APE siRNA and then injected into an animal, a tumor was formed but it did not grow for 10 days as did its control counterpart with a scrambled RNA transfection; after the lag period the tumors with siRNA began to grow at the same rate as the control tumors. It was determined from a parallel experiment that the level of APE was diminished by approximately 90% during the growth lag period. These experiments are being repeated and similar experiments are being set up with other gene targets.

## **KEY RESEARCH ACCOMPLISHMENTS**

### **Project 2:**

1. Validation of the efficacy of a peptide-based inhibitor to DNA-PK in lowering ovarian cancer cell growth following ionizing radiation
2. Establishment of adenoviral expression of Ku80

### **Project 3:**

--Wild-type and mutant p57<sup>Kip1</sup> proteins both interact with CDK2; however the amount of CDK2 associated with the mutant p57<sup>Kip2</sup> is reduced.

--p27<sup>Kip1/T187A</sup>, the stabilized version of the p27<sup>Kip1</sup> protein, is a more effective inhibitor of tumor cell growth when compared to wild-type p27<sup>Kip1</sup>, wild-type p57<sup>Kip2</sup> or mutant p57<sup>Kip2</sup>.

--Folate-PEG-poly-L-lysine complexes can be successfully used to transfect plasmid DNA expression vectors to ovarian cancer cells *in vitro*.

--*In vivo* bioluminescent imaging of i.p. tumors is a possible new tool to study ovarian cancer tumor growth/regression in a murine model system.

**Project 4:**

- The HE4 promoter was active in 5/7 ovarian cancer cell lines with the range of activity spanning 0.06-3-fold that observed for a positive control, co-transfected reporter construct.
- Minimal pHE4-652 promoter activity was observed in the non-ovarian tumor cell lines and normal cells.
- The *hTERT* and the OSP1 promoters were active in the ovarian cancer lines. *hTERT* activity was highest in the CP70 cell line, and OSP1 activity was highest in the SKOV-3x cell line.
- Modest OSP1 and *hTERT* promoter activity was observed in normal cell lines and in selected non-ovarian cancer cell lines.
- This is the first report using the pHE4-652 promoter to drive specific reporter gene expression in epithelial ovarian cancer cell lines.
- We are continuing to develop this promoter for use in transcriptional targeting in ovarian cancer gene therapy.

**Core A:**

- Established protocols for in vivo imaging of intraperitoneal tumor growth
- Established the effectiveness of the siRNA technology to reduce target gene expression and thereby affect cellular growth

**REPORTABLE OUTCOMES****Manuscripts**

Kim, C-H, Park, S-J, and Lee, S-H (2002) Sensitization of breast cancer cells by a targeted inhibition of DNA-dependent protein kinase. *J. Pharm. Exp. Ther.* **303** (2), 753-759.

Lee, S-H. and Kim, C-H. (2002) DNA-Dependent Protein Kinase Complex: a Multifunctional Protein in DNA Repair and Damage Checkpoint. *Molecules and Cells* **13**(2), 159-166.

Park, S-J, Armstrong, S.A., Kim, C-H., Robertson, K., Kelley, M., and Lee, S-H. (2002) Lack of EGF receptor contributes to the drug sensitivity in human germline cells. *Cancer Research* (submitted)

Berry NB, Cho YM, Harrington MA, Williams SD, Foley J, Nephew KP  
Transcriptional targeting in ovarian cancer cells using the HE4 promoter  
(Submitted)

Some of the findings outlined in this report will be included as part of future grant applications to extramural funding agencies, such as the National Institutes of Health.

The pHE4 promoter can be used in the future development of a transgenic animal model for ovarian cancer.

## **CONCLUSIONS:**

### **Project 2:**

The overall goal of this proposal is to explore the role of DNA-PK in the development and progression of breast cancer. Since DNA-PK is a DNA repair factor as well as involved in damage signaling pathway, levels of DNA-PK activity among breast cancer would contribute to their drug resistance and also provide the basis for selection of patients for treatment with chemotherapy drugs.

From the first year of the study we concluded that a peptide-based inhibitor preventing DNA-PKcs from forming a complex with Ku70/Ku80 significantly lowered DNA-PK activity. Furthermore, treatment of these breast cancer cells with target peptide significantly lowered the cell growth only in the presence of ionizing radiation, indicating that the peptide-based inhibitor exhibited a positive effect of on lowering drug resistance by specifically targeting DNA-PK *in vivo*. This result also validates a physiologic role for DNA-PK in chemotherapy drug resistance of breast cancers.

### **Project 3:**

Our results have indicated that the p57<sup>Kip2</sup> mutant protein was not stabilized, and the p27<sup>Kip1/T187A</sup> is a more efficient and effective inhibitor of tumor cell growth. Thus, we are focusing our future studies on the stabilized version of p27<sup>Kip1</sup>, i.e. P27<sup>Kip1/T187A</sup>. We are currently investigating the use of folate to direct liposomes containing p27<sup>Kip1/T187A</sup> plasmids to tumors in the peritoneal cavity of tumor bearing mice. We believe that a folate-target delivery of p27<sup>Kip1/T187A</sup> will be highly efficient and specific method to transfect ovarian cancer cells.

### **Project 4:**

In summary, we have isolated 652bp of the HE4 promoter, a gene that is overexpressed in ovarian cancer and a potential serum tumor marker for ovarian tumors. Using transient transfection assays, we have shown that pHE4-652 is capable of driving high expression of luciferase specifically in ovarian cancer cells. The HE4 promoter thus appears to be a novel addition to the list of promoters for ovarian cancer gene therapy. Another WAP family

member, SLP1, has recently been used for gynecological cancer gene therapy [17], further supporting the use of HE4 and other WAP promoters in reproductive cancer gene therapy.

For the "so what section", which evaluates the knowledge as a scientific or medical product to also be included in the conclusion of this report, we would like to point out that few animal models exist to ovarian cancer, which is a severe limitation both for understanding the basic biology of this devastating disease and testing novel therapeutics for epithelial ovarian cancer. The lack of promoters to drive oncogene expression specifically in the ovarian epithelium is a key limitation, if not the major barrier, to developing a transgenic mouse model of the disease. Providing that the novel promoters identified in Project 4 are expressed in normal ovarian epithelium, we will use them to target oncogenes specifically to the mouse ovarian epithelium and thus be useful in the future for developing a transgenic model for epithelial ovarian cancer.

### **Core A**

- Intraperitoneal tumors can be followed by either micro-PET/micro-CT or by use of stably transfected cell lines expression luciferase; the latter technique is much less labor and technology intensive. Tumor growth can be inhibited by reducing APE expression

### **REFERENCES:**

#### **Project 2:**

Gell D, Jackson SP. (1999) Mapping of protein-protein interactions within the DNA-dependent protein kinase complex. *Nucleic Acids Res.* 27(17), 3494-3502.

Hammarsten O, Chu G. (1998) DNA-dependent protein kinase: DNA binding and activation in the absence of Ku. *Proc Natl Acad Sci USA.* 95(2):525-530.

Kim, C-H, Park, S-J, and Lee, S-H (2002) Targeted inhibition of Ku70/Ku80 and DNA-PKcs interaction sensitizes breast cancer cells following ionizing radiation. *J. Pharm. Exp. Ther.* 303 (2), 753-759.

Kirchgessner CU, Patil CK, Evans JW, Cuomo CA, Fried LM, Carter T, Oettinger MA, Brown JM. (1995) DNA-dependent kinase (p350) as a candidate gene for the murine SCID defect. *Science.* 267, 1178-1183.

Lee, S-H. and Kim, C-H. (2002) DNA-Dependent Protein Kinase: A multifunctional protein in DNA repair and damage checkpoint. *Mol. and Cells* 13 (2), 159-166.

Lees-Miller SP, Godbout R, Chan DW, Weinfeld M, Day RS 3rd, Barron GM, Allalunis-Turner J. (1995) Absence of p350 subunit of DNA-activated protein kinase from a radiosensitive human cell line. *Science*. 267,1183-1185.

Lin, YZ, Yao SY, Veach RA, Torgerson TR, Hawiger J (1995) Inhibition of nuclear translocation of nuclear transcription factor NF-KB by a synthetic peptide containing cell membrane-permeable motif and nuclear localization sequence. *J. Biol. Chem.*, 270(24), 14255-14258.

Muller, C., Calsou, P., Frit, P., Cayrol, C., Carter, T. and Salles, B. (1998) UV sensitivity and impaired nucleotide excision repair in DNA-dependent protein kinase mutant cells. *Nucleic Acids Res.*, 26, 1382-1389.

#### Project 4:

1. **Shridhar V, Lee J, Pandita A, et al.** 2001 Genetic analysis of early-versus late-stage ovarian tumors. *Cancer Res* 61:5895-904
2. **Hough CD, Sherman-Baust CA, Pizer ES, et al.** 2000 Large-scale serial analysis of gene expression reveals genes differentially expressed in ovarian cancer. *Cancer Res* 60:6281-7
3. **Ono K, Tanaka T, Tsunoda T, et al.** 2000 Identification by cDNA microarray of genes involved in ovarian carcinogenesis. *Cancer Res* 60:5007-11
4. **Schummer M, Ng WV, Bumgarner RE, et al.** 1999 Comparative hybridization of an array of 21,500 ovarian cDNAs for the discovery of genes overexpressed in ovarian carcinomas. *Gene* 238:375-85
5. **Welsh JB, Zarrinkar PP, Sapinoso LM, et al.** 2001 Analysis of gene expression profiles in normal and neoplastic ovarian tissue samples identifies candidate molecular markers of epithelial ovarian cancer. *Proc Natl Acad Sci U S A* 98:1176-81
6. **Wang K, Gan L, Jeffery E, et al.** 1999 Monitoring gene expression profile changes in ovarian carcinomas using cDNA microarray. *Gene* 229:101-8
7. **Schaner ME, Ross DT, Ciaravino G, Sorlie T, Troyanskaya O, Diehn M, Wang YC, Duran GE, Sikic TL, Caldeira S, Skomedal H, Tu IP, Hernandez-Boussard T, Johnson SW, O'Dwyer PJ, Fero MJ, Kristensen GB, Borresen-Dale AL, Hastie T, Tibshirani R, Van De Rijn M, Teng NN, Longacre TA, Botstein D, Brown PO, Sikic BI.** Gene expression patterns in ovarian carcinomas. *Mol Biol Cell*. 2003 Sep 5 [Epub ahead of print].

8. **Hellstrom I, Raycraft J, Hayden-Ledbetter M, et al.** 2003 The HE4 (WFDC2) protein is a biomarker for ovarian carcinoma. *Cancer Res* 63:3695-700
9. **Bingle L, Singleton V, Bingle CD** 2002 The putative ovarian tumour marker gene HE4 (WFDC2), is expressed in normal tissues and undergoes complex alternative splicing to yield multiple protein isoforms. *Oncogene* 21:2768-73
10. **Kirchhoff C, Habben I, Ivell R, Krull N** 1991 A major human epididymis-specific cDNA encodes a protein with sequence homology to extracellular proteinase inhibitors. *Biol Reprod* 45:350-7
11. **Bao R, Selvakumaran M, Hamilton TC** 2002 Targeted gene therapy of ovarian cancer using an ovarian-specific promoter. *PG - 228-34. Gynecol Oncol* 84
12. **Selvakumaran M, Bao R, Crijns AP, Connolly DC, Weinstein JK, Hamilton TC** 2001 Ovarian epithelial cell lineage-specific gene expression using the promoter of a retrovirus-like element. *PG - 1291-5. Cancer Res* 61
13. **Tanyi JL LR, Eder A, Auersperg N, Tabassam FH, Roth JA, Gu J, Fang B, Mills GB, Wolf J.** 2002 Identification of tissue- and cancer-selective promoters for the introduction of genes into human ovarian cancer cells. *Gynecol Oncol* 85:451-8
14. **Cong YS, Wen J, Bacchetti S** 1999 The human telomerase catalytic subunit hTERT: organization of the gene and characterization of the promoter. *Hum Mol Genet* 8:137-42
15. **Kyo S, Kanaya T, Takakura M, et al.** 1999 Expression of human telomerase subunits in ovarian malignant, borderline and benign tumors. *Int J Cancer* 80:804-9
16. **Liu K, Schoonmaker MM, Levine BL, June CH, Hodes RJ, Weng NP** 1999 Constitutive and regulated expression of telomerase reverse transcriptase (hTERT) in human lymphocytes. *Proc Natl Acad Sci U S A* 96:5147-52
17. **Robertson MW, 3rd, Wang M, Siegal GP, et al.** 1998 Use of a tissue-specific promoter for targeted expression of the herpes simplex virus thymidine kinase gene in cervical carcinoma cells. *Cancer Gene Ther* 5:331-6

#### APPENDIX:

Manuscript: Berry NB, Cho YM, Harrington MA, Williams SD, Foley J, Nephew KP Transcriptional targeting in ovarian cancer cells using the HE4 promoter (Submitted)

## Transcriptional Targeting in Ovarian Cancer Cells Using the HE4 Promoter

Nicholas B. Berry<sup>1</sup>, Yong Mee Cho<sup>1</sup>, Maureen A. Harrington<sup>2,3,4</sup>, Stephen D. Williams<sup>2</sup>,  
John Foley<sup>1,2,5</sup>, Kenneth P. Nephew<sup>1,2,4,5,6</sup>

<sup>1</sup>Medical Sciences, Indiana University School of Medicine, Bloomington, Indiana 47405;

<sup>2</sup>Indiana University Cancer Center, Indianapolis, Indiana, 46202

<sup>3</sup>Dept. of Biochemistry, Indiana University School of Medicine, Indianapolis, Indiana, 46202

<sup>4</sup>Walther Oncology Center, Indianapolis, Indiana

10 <sup>5</sup>Walther Cancer Institute, Bloomington, Indiana

<sup>6</sup>To whom correspondence should be addressed:

Kenneth P. Nephew, Ph.D.  
Indiana University School of Medicine  
Medical Sciences  
302 Jordan Hall  
1001 East 3<sup>rd</sup> Street  
Bloomington, IN 47405, USA.  
Tel: 812-855-9445  
Fax: 812-855-4436  
E-mail: [knephew@indiana.edu](mailto:knephew@indiana.edu)

**Abbreviations:**

CMV, cytomegalovirus; ER, estrogen receptor; FSH, follicular stimulating hormone; luc, Luciferase; HE4, human epididymis protein 4; HSVTK, Herpes Simplex Virus Thymidine Kinase; *hTERT*, human telomerase reverse transcriptase; NHF, Normal Human Fibroblasts; NHK, Normal Human Keratinocytes; OSP1, ovarian specific promoter-1; RLU, relative luciferase units; RORA, RAR-related orphan receptor; SV40, simian virus 40

*Objective:* Limitations of current ovarian cancer gene therapies include lack of specificity and transduction of normal tissues. One strategy toward overcoming these limitations is to direct  
30 gene therapy specifically to ovarian cancer cells by using tissue/tumor specific promoters. The  
whey acidic protein HE4 is frequently overexpressed in ovarian cancer, suggesting that the HE4  
promoter is highly transcriptionally active in the disease. The objective of this study was to  
isolate the HE4 promoter and examine its ability to selectively activate reporter gene expression  
in an ovarian cancer specific manner.

*Methods.* To investigate transcriptional targeting in ovarian cancer gene therapy, we isolated a  
region of the HE4 promoter from -407 to +73 (pHE4-652; relative to the ATG start site of HE4)  
and placed it upstream of a luciferase reporter gene plasmid to generate pHE4-652-luc. The  
activity of the pHE4-652-luc reporter construct was characterized in transient transfection assays  
in a panel of epithelial ovarian cancer cell lines (SKOV-3, SKOV-3x, CP70, HeyC2, A2780,  
40 A2780CP, OVCAR-3), non-ovarian tumor cell lines, and primary cultures of normal cells. The  
activity of two other candidate gene therapy promoters, *hTERT* and *OSP1*, was also  
characterized in these cell lines.

*Results.* The HE4 promoter was active in 5/7 ovarian cancer cell lines with the range of activity  
spanning 0.06-3-fold that observed for a positive control, co-transfected reporter construct (SV-  
40-luc). Minimal pHE4-652 promoter activity, defined as  $\leq 5\%$  of the activity detected with the  
SV-40-luc construct, was observed in the non-ovarian tumor cell lines and normal cells. The  
*hTERT* and the *OSP1* promoters were active in the ovarian cancer lines. *hTERT* activity was  
highest in the CP70 cell line, and *OSP1* activity was highest in the SKOV-3x cell line. Modest  
*OSP1* and *hTERT* promoter activity was observed in normal cell lines and in selected non-  
50 ovarian cancer cell lines.

*Conclusion.* This is the first report using the pHE4-652 promoter to drive specific reporter gene expression in epithelial ovarian cancer cell lines, and we are continuing to develop this promoter for use in transcriptional targeting in ovarian cancer gene therapy.

**Keywords:** Gene Therapy, Gynecologic Oncology, Tissue Specific Promoter

## INTRODUCTION

Ovarian cancer is the most lethal gynecologic cancer and most common cause of death from gynecologic cancer in the United States [1]. The disease is often asymptomatic in its early stages, and due to the lack of effective prevention and screening modalities, most patients usually have widespread intraperitoneal disease at the time of diagnosis [2]. Despite the fact that the majority of ovarian cancer patients enter clinical remission following surgery and a platinum- and taxane-containing regimen, most will develop recurrent disease and eventually succumb to their cancer [3, 4]. Current therapies for recurrent ovarian cancer are frequently ineffective [4, 5], and novel treatment strategies are needed.

Gene therapy may provide a treatment option for ovarian cancer patients, either alone or by increasing the sensitivity of the cancer cells to existing therapies to overcome chemotherapy resistance (reviewed in [6, 7]). Because the disease remains confined mainly to the abdominal cavity even in the advanced stages [8], and the abdominal cavity remains highly accessible in ovarian cancer patients, it is possible to achieve higher vector concentrations with minimal tissue distribution and toxicity [9]. Despite this potential advantage for delivering the therapeutic vector, significant limitations still exist for ovarian cancer gene therapy, mainly toxicity due to nonspecific transduction of normal tissues. The most direct approach to overcoming this limitation is the use of tissue/tumor specific promoters. Several candidate promoters have been used to control therapeutic gene expression in ovarian cancer cells. The human chorionic gonadatropin (hCG) promoter, when subcloned upstream of diphtheria toxin-A chain gene in a retrovirus, showed selective killing of a number of ovarian cancer cell lines with minimal toxicity to normal ovary and fibroblasts [10]. The serine leukocyte protease inhibitor-1 (SLP1) promoter has also been used to drive herpes simplex thymidine kinase (HSVtk) in SKOV-3 cells

80 [11]. Furthermore, cancer-specific promoters such as the telomerase gene promoter (*hTERT*) [12] have been examined for gene therapy of ovarian cancer [13, 14]. Additional approaches, including artificial promoters combined with highly efficient gene transfer vectors, may increase the therapeutic index and reduce toxicity, but have not yet been tested for ovarian cancer gene therapy. Thus, lack of therapeutic vector fidelity for cancer cells continues to be a major issue confronting successfully targeted gene therapy for ovarian cancer [15].

Promoters of genes frequently upregulated in ovarian cancer may provide a means to direct expression of a therapeutic gene specifically in ovarian cancer cells. Upregulation of whey-acidic proteins in cancer appears to be due to a transcriptional event [16]. A small whey-acidic secretory (WAP) protein called HE4 has recently been shown to be overexpressed in  
90 ovarian cancer [17-23]. Originally described as an epididymis-specific gene [24], HE4 (also known as WFDC2) has homology with a number of secreted serine protease inhibitors, including elafin, SLP1, and eppin [25]. These WAP family members are thought to play a role in regulation of secreted proteolytic enzymes [26]. The potential use of HE4 as a biomarker for ovarian cancer has recently been described [20, 27].

In the present study, we investigated the HE4 gene promoter for potential use in the transcriptional targeting of ovarian cancers. We isolated the HE4 promoter and compared its activity in ovarian cancer cells with the activity of two established cancer gene promoters, *hTERT* [12] and ovarian specific promoter-1 (OSP1) [28]. The HE4 gene promoter is capable of driving high expression of a reporter gene specifically in cancer cell lines derived from the  
100 ovarian epithelium. These findings indicate that the HE4 promoter should be included future approaches focused on transcriptional targeting strategies for ovarian cancer gene therapy.

## MATERIALS AND METHODS

### *Promoter Constructs*

A BAC clone (GenBank Accession # AL031663) containing the full length HE4 gene was purchased from BACPAC Resources (Children's Hospital Oakland Research Institute, Oakland, CA) and analyzed using the Genomatix promoter prediction program CHIP2 (<http://www.genomatix.de>). A 2071bp fragment surrounding the putative promoter region was amplified using the forward primer 5'-GACAGAAACACACACCCAAACGGCTTG-3' and the reverse primer 5'-TGGAAGAGATTGACTGAAAGACGACGAAGG-3' with the following cycle profile: 95° for 30 sec., 62° for 30 sec., 72° for 2 minutes for 30 cycles with a 10 minute final extension at 72°. The size of the PCR product was verified and digested using convenient restriction sites to isolate four promoter regions, pHE4-1308, -799, -652, and -395. pHE4-1308 contains the core HE4 promoter region (-407 to +73) as well as the entire first exon of HE4. pHE4-652 includes an additional 122bp upstream region (-530 to -407) than other three constructs. Promoter fragments were ligated into the pGL-2-Basic vector (Promega) for transient transfection assays (Figure 1A). The negative control construct, TATA-luc, was created by placing the minimal mPThrP TATA promoter sequence (46 bases upstream from the transcription start site and 50 bases of a non translated exon) upstream of luciferase in the multiple cloning site of pGL2-Basic [29]. The positive control vector, pGL2-Control (Promega), uses the SV40 promoter and enhancer to drive high expression of luciferase.

The *hTERT* construct, kindly provided by Silvia Bacchetti (McMaster University, Ontario, Canada), contained 444bp upstream of the *hTERT* start site, the entire first exon and first intron, and 37bp of exon 2 (817bp total) placed upstream of pGL2-enhancer [12]. OSP1 (kindly provided by Thomas Hamilton, Fox Chase Cancer Center, Philadelphia, PA) was isolated

from the U3 portion of a 5' long terminal repeat in a rat retroviral-like genomic element [30]. It consisted of 472bp cloned into pGL3 vector [9]. All constructs were sequenced for correct orientation and directionality. Potential transcription factor binding boxes for pHE4-652 were identified using MATInspector v2.2 using the constraints 100% core, 85% similarity for the flanking region (<http://transfac.gbf.de/programs/matinspector/matinspector.html>) [31].

130 The pHE4-652, *hTERT*, and OSP1 promoters were aligned using using T-Coffee (<http://www.ch.embnet.org/software/TCoffee.html>) [32] and a sequence comparison was made using the Needleman-Wunsch global alignment program (<http://sunflower.bio.indiana.edu/bioweb/seqanal/interfaces/needle.html>).

#### *Cell Lines and Cell Culture*

All cell lines were maintained in a humidified incubator at 37°C and 5% CO<sub>2</sub>. OVCAR-3 and SKOV-3 were purchased from American Type Culture Collection (Rockville, MD). Culture conditions for the human epithelial ovarian cancer cell lines HeyC2, OVCAR-3, SKOV-3, and CP70 have been described previously [33; 34]. CP70 cells were kindly provided by Dr. R. Brown (University of Glasgow, Glasgow UK). The SKOV-3x cell line was derived from SKOV-3 grown as xenografts in nude mice and was maintained in McCoy's modified media supplemented with 10% FBS. A2780 epithelial ovarian cancer cells, NPA thyroid cancer cells, and MCF7 human breast cancer cells were grown in DMEM, supplemented with 6ng/ml insulin. Normal ovarian surface epithelial cells (nOSE) and immortalized OSE (IOSE) cells were maintained in medium 155/199 (Sigma) supplemented with 10% FBS, 10ng/ml EGF (Sigma), and 400ng/ml hydrocortisone (Sigma). Primary keratinocytes were maintained in EpiLife Media and human keratinocyte growth supplements (Cascade Biologics) supplemented with 10% FBS

140

(Hyclone). HeLa cervical carcinoma cells were maintained as described previously [35].

Normal human fibroblasts (NHF) were maintained in the same media used for HeLa cells.

150

### *Transient Transfection*

Transient transfection assays were carried out as described by Fan et al [35]. Briefly,  $1.5 \times 10^5$  cells were seeded in each well of a 12-well dish 24 h prior to transfection. HeLa, OVCAR-3, SKOV-3, SKOV-3x, CP70, NPA, A2780, A2780CP, and MCF7 cells were transfected with 1  $\mu$ g total DNA using LipofectAMINE and PLUS Reagent, according to the manufacturer's guidelines. The concentration of total DNA was adjusted to 1  $\mu$ g/well with Promega pGEM3z vector. For transfection assays using HeyC2 cells, Tfx-20 in OPTI-MEM was used in a 2:1 lipid:DNA ratio with 0.5  $\mu$ g DNA/well. Five hours after transfection, media was replaced, and 24 h later cells were lysed using Reporter Lysis Buffer (Promega). Primary keratinocytes, nOSE, and IOSE were transfected with Fugene (Roche, Indianapolis, IN) at a 6:1 ratio with a total of 1  $\mu$ g/well DNA. Cells were transfected for 48 h. NHF cells were transfected with Fugene at a 3:2 ratio with 1  $\mu$ g DNA/well for 48 h. All cells were cotransfected with pCMV- $\beta$ -gal (10ng/well) to correct for transfection efficiency. Cells and lysates were collected, cell membranes were disrupted by sonication (1.5 seconds) using a Branson Sonifier (Danbury, CT), and then centrifuged. Luciferase and  $\beta$ -gal activity was determined using the Promega Luciferase Assay System, Tropix Galacto-light Plus  $\beta$ -gal kit, and the T20/20 Luminometer (Turner Designs, Sunnyvale, CA).

Preliminary transfection experiments using the four HE4 constructs pHE4-1308, -799, -652, -395 DNA were performed to determine the optimal amount of DNA for use in subsequent assays. Each cell line was also transfected with a range of pHE4-652, *hTERT* P-444, and OSP1

170

DNA (200-1000ng), and luciferase values were determined. The amount of DNA yielding maximal luciferase activity for each construct was considered optimal (Table 1 and Figure 2). An equal amount of pGL2-basic, TATA, and SV40-luc was used in transfection assays (equal to the optimized pHE4-652 DNA value for each cell line). CMV- $\beta$ gal was again cotransfected to normalize transfection efficiency. Activity of pHE4-652, *hTERT*, and OSP1 are expressed as relative luciferase units (RLU; luciferase/ $\beta$ -gal) or as RLU/ SV40 promoter-and-enhancer driven luciferase (%SV40). Optimizations were done in quadruplicate and repeated at least twice. Means were compared by one-way ANOVA, and the Student T-test method was used to determine significant ( $p < 0.05$ ) differences between means. Error bars represent standard error of the mean (SEM).

180

## RESULTS

### *pHE4-652 is Active in Epithelial Ovarian Cancer Cell Lines*

Initial testing of HE4 promoter fragments for activity was carried out using optimized HE4 promoter fragment constructs in transient transfection assays of HeLa cervical cancer cells and three ovarian cancer cell lines (SKOV-3, OVCAR-3, and A2780). At all concentrations of the four HE4 constructs tested (200-1000ng/well), minimal activity was observed in HeLa cells, and activity of HE4-395, -799, and -1308 was low in SKOV-3, OVCAR-3 and A2780 cells (Figure 3). In contrast, activity of pHE4-652 was observed in all three ovarian cancer cell lines.

190

Therefore, pHE4-652 was chosen for use in subsequent experiments.

### *Optimization of Reporter Gene Constructs in Cell Lines*

The optimization experiments were performed to ensure highest luciferase values for pHE4-652, *hTERT*, and OSP1 in each cell line (Table 1). All epithelial ovarian cancer cell lines, cancer lines of non-ovarian origin, and normal cells were transfected with increasing amounts of pHE4-652 DNA (200-1000ng) and assayed for luciferase activity. Activity of pHE4-652, compared to TATA-luc, was seen at 300ng in the NPA cell line ( $P < 0.01$ ; Figure 2). Similar optimization experiments were carried out in each cell line for pHE4-652, *hTERT*-P444, and OSP1. Transfected amounts of DNA were adjusted to 1  $\mu$ g (500ng for HeyC2) using pGEM3z vector and transfection efficiency remained similar. Although pHE4-652 activity in NPA is significantly increased over TATA-luc activity at 300ng, relative to the activity of SV40-luc, the amount of pHE4-652 activity is negligible (0.21%).

### *The HE4 gene promoter Drives Luciferase Expression Specifically in Epithelial Ovarian Cancer Cells*

The activity of the pHE4-652, *hTERT*-P444, OSP1 promoters was compared in epithelial ovarian cancer cell lines, non-ovarian cancer cell lines, and normal cell lines. The level of promoter activity was expressed as a percentage of the activity detected with a luciferase cDNA under the control of the SV40 promoter and enhancer region; independent of the promoter under analysis, all transfections were normalized against a cotransfected CMV- $\beta$ gal. Activity of pHE4-652 was greater ( $p < 0.001$ ) than TATA-driven luciferase in all ovarian cancer cell lines except HeyC2 cells (Figure 4A). The level of pHE4-652 activity was highest in CP70, A2780, A2780CP, and SKOV-3x (20, 31, 82, and 318%, respectively; Figure 4A). Minimal activity of

pHE4-652 was observed in MCF7, NPA, HeLa, nOSE, IOSE and primary fibroblasts (Figure 4B).

#### *Activity of hTERT and OSP1 in Ovarian and Non-Ovarian Cells*

220 To determine if the activity of pHE4 promoter was comparable to that detected for other gene promoters currently undergoing study, we examined the activity of candidate ovarian cancer gene therapy promoters OSP1 and *hTERT*. OSP1 activity was highest ( $P < 0.001$ ) in SKOV-3X (3005%), and also high in the A2780, A2780CP and CP70 cell lines (194%, 405%, and 389% respectively; Figure 5A). However, OSP1 activity was seen in several non-ovarian tumor lines and normal cells, ranging from 9% in MCF7 breast cancer cells to 70% in normal human keratinocytes (Figure 5B). The *hTERT* promoter was active in the majority of ovarian cancer cell lines. The highest *hTERT* activity was observed in the CP70, A2780 and SKOV-3x cell lines (550%, 446% and 300%, respectively; Figure 6A). *hTERT* showed variable activity in the non-ovarian cancer cell lines, ranging from 5% in HeLa to 106% in NPA. *hTERT* was also  
230 active in nOSE and IOSE cells (54% and 17%), as well as in non-tumorigenic lines NHK, NHF (12% and 32%; figure 6B). *hTERT* values increased as nOSE, NHF, and NHK passage number increased (data not shown).

#### *Putative Transcriptional Motifs in pHE4-652*

We examined the HE4 promoter sequence for potential regulatory motifs and identified, at the sequence level, well-known transcriptional elements such as AP1, AP2, and AP4 response elements throughout the promoter region. In addition, sequence motifs for Delta EF, Ikaros 2, NF1, SP1, and MZF1 regulatory elements were found in pHE4-652 (Figure 1B). Located near

the HE4 start site were CREB, GC box and SP1 motifs. Although pHE4-1308, 799, and 652  
240 contain the region surrounding the HE4 translation start site, an additional 122bp upstream  
region is found in pHE4-652 (-530bp vs. -407) that contains NKX25, NFkB, AP1, and RORA  
binding sites. Furthermore, GATA, C-MYB, AHARNT, SRY, ER, SOX5, and another AP1 site  
are found between the proximal and distal portions of pHE4-652 (Figure 1B). Two known  
elements that bind testis determining gene products, SRY and SOX5 [36], were observed at  
-293bp in HE4.

*pHE4-652 Shares an Oncogene Binding Site with hTERT and Hormonal Responsive Elements  
with OSP1*

A comparison of the promoters examined in this study revealed that HE4, *hTERT*, and  
250 OSP1 share the following transcriptional response elements: the tumor responsive element  
CMYB, hormonal responsive elements RORA1, AP1, ER, and inflammatory response elements  
NF1 and NFkB. pHE4-652 also contains a cAMP binding site (CREB) and a sterol regulatory  
element-binding protein site (SREBP1) not present in OSP1 or *hTERT*-P444 (Figure 1B).  
Similar findings for shared elements in *hTERT* and OSP1 have been described [12, 30], and our  
work agrees with studies showing that *hTERT* contains MYC, MAX, MYB, and AP1/ER and  
binding sites [12, 37].

## DISCUSSION

Ovarian cancer is often limited to the peritoneal cavity at the time of diagnosis, making  
260 local gene therapy, such as injection of a therapeutic vector into the abdomen, a treatment option  
for the disease. While this approach may yield less toxicity and/or immune response in general

[9], nonspecific infection of normal cells, the basis of severe toxicity, remains a significant limitation for local ovarian cancer gene therapy. One way to circumvent this problem is to use a tissue/tumor-specific promoter that is capable of directing expression of a therapeutic gene in the ovarian cancer cells and sparing the normal cells. The WAP domain protein HE4 is overexpressed in ovarian cancer [17-23]. This is the first report on the isolation and characterization of the HE4 promoter. Based on the results that the pHE4-652 promoter is able to drive reporter gene expression specifically in epithelial ovarian cancer cell lines, we suggest that the pHE4-652 promoter is capable of restricting the expression of a therapeutic gene to ovarian tumor cells.

270

Several hormonal responsive elements are found within the pHE4-652 promoter, including ER and RORA, which may play a role in HE4 upregulation in ovarian cancer and ovarian cancer specificity. Estrogen response elements have also been used to drive tissue specific expression of gene therapy genes in breast cancer [38]. In addition, pHE4-652 contains a cAMP inducible element (CEBP), and this class of motifs has been shown to induce FSH responsive genes in rat ovarian cells [39]. Earlier work on the WAP family member elafin by Zhang et al [40] showed through deletion analysis and mutagenesis that the elafin promoter is under control of an Ap1 site and induced by PMA in breast tumors. It is reasonable to suggest that one or more of the seven Ap1 sites found in pHE4-652 could contribute to its high activity in ovarian cancer cells. Thus, while the promoter elements responsible for ovarian cancer specificity of pHE4-652 have not yet been identified, we are currently examining the various response elements and determining their contribution to HE4 promoter activity.

280

Several studies have shown that HE4 is overexpressed in early and late stage ovarian cancer [18-24]. The mechanism associated with HE4 overexpression in ovarian tumors has not

been defined, but our results demonstrating minimal HE4 promoter activity in nOSE and IOSE cells suggests the factors responsible for upregulating HE4 expression in ovarian cancer cells are not present in normal ovarian epithelial cells in culture. In support, HE4 is not expressed in normal bovine ovary, early and late corpus luteum, and fallopian tube [24]. WAP family members have been shown to be induced by pro-inflammatory stimuli during injury [41, 42],  
290 display antiprotease action and suppress inflammatory proteases [43]. Thus, WAP family members are thought to protect cells or tissues against unregulated proteolytic enzymes during inflammation [44]. It is well documented that during ovulation, the ovarian surface epithelium is the site of periodic injury and inflammation, and this inflammatory process is also strongly associated with ovarian cancer etiology [45]. The presence of several inflammatory responsive elements (NF $\kappa$ B, Ikaros, LYF-1) in the HE4 promoter and the upregulation of NF $\kappa$ B in ovarian cancer cells [46] lends further support for the potential role of inflammation in the upregulation of HE4 in ovarian cancer. Collectively, these observations allow us to raise the possibility that inflammatory responsive elements may contribute to the high expression of HE4 in ovarian cancer. However, the biological role or consequence of HE4 overexpression in ovarian cancer  
300 remains to be elucidated.

HE4 is a complex gene, composed of five exons that can result in the production of several splice variants yielding multiple mRNA species [26]. Each splice variant may be regulated by a distinct promoter region(s), and although HE4 has been shown to be upregulated to some degree in breast cancer cells [23], in the present study pHE4-652 was not active in MCF7 cells. Thus, upregulation of HE4 in breast and other cancers appears to be under the control of sequences not contained in pHE4-652. Furthermore, the pHE4-652 promoter showed activity in most, but not all, of the ovarian cancer cell lines tested in this study. Maximal SV40

values were also considerably lower in OVCAR3, SKOV3, and HEYC2 cells, suggesting that the low pHE4-652 activity may be due to a cell-specific factors influencing overall transcriptional activity in these particular ovarian cancer cell lines. Curiously, OSP1 and *hTERT*-P444 constructs also showed limited activity in OVCAR3, SKOV3, and HEYC2 cells. Our data showing that the OSP1 promoter is capable of driving reporter gene expression in tissues other than the ovary agrees with the results of recent study by Garson et al [47] using the OSP1 promoter placed upstream of SV40 in a mouse model for ovarian cancer. In that study, T-antigen expression was seen in both ovarian and non-ovarian mouse tissues.

In summary, we have isolated 652bp of the HE4 promoter, a gene that is overexpressed in ovarian cancer and a potential serum tumor marker for ovarian tumors [20]. Using transient transfection assays, we have shown that pHE4-652 is capable of driving high expression of luciferase specifically in ovarian cancer cells. The HE4 promoter thus appears to be a novel addition to the list of promoters for ovarian cancer gene therapy. Another WAP family member, SLP1, has recently been used for gynecological cancer gene therapy [8], further supporting the use of HE4 and other WAP promoters in reproductive cancer gene therapy.

#### ACKNOWLEDGEMENTS

The authors would like to thank the following investigators for providing crucial reagents: Dr. T. Hamilton (Fox Chase Cancer Center, Philadelphia, PA) for the OSP1 construct and the A2780 cell line; Dr. S. Bacchetti (McMaster University, Ontario, Canada) for *hTERT*-P444, Dr. J. Spandau (Indiana University School of Medicine) for NHF and NHK cell lines; Dr. G. Mills (MD Anderson Cancer Center, Houston, TX) for HeyC2 cell lines, Dr. R. Bigsby and B. Allison (Indiana University School of Medicine) for nOSE and SKOV-3x; Dr. D. Matei (Indiana

University School of Medicine) for IOSE cell lines; Dr. R. Brown (University of Glasgow, Glasgow UK) for CP70 cells. We thank the members of the Ovarian Cancer Program Project Group for helpful discussions, and Sheri Wildt for excellent technical assistance. This work was supported by United States Army, Department of Defense Ovarian Research Program Project Grant # OC000113 (to SDW).

## REFERENCES:

1. **Greenlee RT, Hill-Harmon MB, Murray T, Thun M** 2001 Cancer statistics, 2001. *CA Cancer J Clin* 51:15-36
2. **Martin VR** 2002 Ovarian cancer. *Semin Oncol Nurs* 18:174-83
3. **Chi DS, Sabbatini P** 2000 Advanced ovarian cancer. *Curr Treat Options Oncol* 1:139-46
4. **Ozols RF** 2002 Future directions in the treatment of ovarian cancer. *Semin Oncol* 29:32-42
5. **Peethambaram PP, Long HJ** 2002 Second-line and subsequent therapy for ovarian carcinoma. *Curr Oncol Rep* 4:159-64
6. **Wolf JK, Jenkins AD** 2002 Gene therapy for ovarian cancer (review). *Int J Oncol* 21:461-8
7. **Barnes MN, Coolidge CJ, Hemminki A, Alvarez RD, Curiel DT** 2002 Conditionally replicative adenoviruses for ovarian cancer therapy. *Mol Cancer Ther* 1:435-9
8. **Robertson MW, 3rd, Wang M, Siegal GP, et al.** 1998 Use of a tissue-specific promoter for targeted expression of the herpes simplex virus thymidine kinase gene in cervical carcinoma cells. *Cancer Gene Ther* 5:331-6
9. **Tanyi JL LR, Eder A, Auersperg N, Tabassam FH, Roth JA, Gu J, Fang B, Mills GB, Wolf J.** 2002 Identification of tissue- and cancer-selective promoters for the introduction of genes into human ovarian cancer cells. *Gynecol Oncol* 85:451-8
10. **Lidor YJ, Lee WE, Nilson JH, et al.** 1997 In vitro expression of the diphtheria toxin A-chain gene under the control of human chorionic gonadotropin gene promoters as a means of directing toxicity to ovarian cancer cell lines. *Am J Obstet Gynecol* 177:579-85
11. **Garver RI, Jr., Goldsmith KT, Rodu B, Hu PC, Sorscher EJ, Curiel DT** 1994 Strategy for achieving selective killing of carcinomas. *Gene Ther* 1:46-50
12. **Cong YS, Wen J, Bacchetti S** 1999 The human telomerase catalytic subunit hTERT: organization of the gene and characterization of the promoter. *Hum Mol Genet* 8:137-42
13. **Bilsland AE, Anderson CJ, Fletcher-Monaghan AJ, et al.** 2003 Selective ablation of human cancer cells by telomerase-specific adenoviral suicide gene therapy vectors expressing bacterial nitroreductase. *Oncogene* 22:370-80
14. **Hiyama E, Hiyama K** 2002 Clinical utility of telomerase in cancer. *Oncogene* 21:643-9
15. **Bauknecht T, Meinhold-Heerlein I** 2002 Gene therapy of ovarian cancer. *Curr Womens Health Rep* 2:39-46
16. **Zhang Y, DeWitt DL, McNeely TB, Wahl SM, Wahl LM** 1997 Secretory leukocyte protease inhibitor suppresses the production of monocyte prostaglandin H synthase-2, prostaglandin E2, and matrix metalloproteinases. *J Clin Invest* 99:894-900
17. **Hough CD, Sherman-Baust CA, Pizer ES, et al.** 2000 Large-scale serial analysis of gene expression reveals genes differentially expressed in ovarian cancer. *Cancer Res* 60:6281-7
18. **Shridhar V, Lee J, Pandita A, et al.** 2001 Genetic analysis of early- versus late-stage ovarian tumors. *Cancer Res* 61:5895-904
19. **Ono K, Tanaka T, Tsunoda T, et al.** 2000 Identification by cDNA microarray of genes involved in ovarian carcinogenesis. *Cancer Res* 60:5007-11
20. **Schummer M, Ng WV, Bumgarner RE, et al.** 1999 Comparative hybridization of an array of 21,500 ovarian cDNAs for the discovery of genes overexpressed in ovarian carcinomas. *Gene* 238:375-85
21. **Welsh JB, Zarrinkar PP, Sapinoso LM, et al.** 2001 Analysis of gene expression profiles in normal and neoplastic ovarian tissue samples identifies candidate molecular markers of epithelial ovarian cancer. *Proc Natl Acad Sci U S A* 98:1176-81
22. **Wang K, Gan L, Jeffery E, et al.** 1999 Monitoring gene expression profile changes in ovarian carcinomas using cDNA microarray. *Gene* 229:101-8
23. **Ross DT, Scherf U, Eisen MB, et al.** 2000 Systematic variation in gene expression patterns in human cancer cell lines. *Nat Genet* 24:227-35
24. **Kirchhoff C, Habben I, Ivell R, Krull N** 1991 A major human epididymis-specific cDNA encodes a protein with sequence homology to extracellular proteinase inhibitors. *Biol Reprod* 45:350-7
25. **Clauss A, Lilja H, Lundwall A** 2002 A locus on human chromosome 20 contains several genes expressing protease inhibitor domains with homology to whey acidic protein. *Biochem J* 368:233-42

- 390 26. **Bingle L, Singleton V, Bingle CD** 2002 The putative ovarian tumour marker gene HE4 (WFDC2), is expressed in normal tissues and undergoes complex alternative splicing to yield multiple protein isoforms. *Oncogene* 21:2768-73
27. **Hellstrom I, Raycraft J, Hayden-Ledbetter M, et al.** 2003 The HE4 (WFDC2) protein is a biomarker for ovarian carcinoma. *Cancer Res* 63:3695-700
28. **Selvakumaran M, Bao R, Crijns AP, Connolly DC, Weinstein JK, Hamilton TC** 2001 Ovarian epithelial cell lineage-specific gene expression using the promoter of a retrovirus-like element. *Cancer Res* 61:1291-5
29. **Foley J, Wysolmerski JJ, Missero C, King CS, Philbrick WM** 1999 Regulation of parathyroid hormone-related protein gene expression in murine keratinocytes by E1A isoforms: a role for basal promoter and Ets-1 site. *Mol Cell Endocrinol* 156:13-23
- 400 30. **Selvakumaran M, Bao R, Crijns AP, Connolly DC, Weinstein JK, Hamilton TC** 2001 Ovarian epithelial cell lineage-specific gene expression using the promoter of a retrovirus-like element. PG - 1291-5. *Cancer Res* 61
31. **Wingender E, Chen X, Hehl R, et al.** 2000 TRANSFAC: an integrated system for gene expression regulation. *Nucleic Acids Res* 28:316-9
32. **Notredame C, Higgins DG, Heringa J** 2000 T-Coffee: A novel method for fast and accurate multiple sequence alignment. *J Mol Biol* 302:205-17
33. **Ahluwalia A, Yan P, Hurteau JA, et al.** 2001 DNA methylation and ovarian cancer. I. Analysis of CpG island hypermethylation in human ovarian cancer using differential methylation hybridization. *Gynecol Oncol* 82:261-8
- 410 34. **Shi H, Wei SH, Leu YW, et al.** 2003 Triple analysis of the cancer epigenome: an integrated microarray system for assessing gene expression, DNA methylation, and histone acetylation. *Cancer Res* 63:2164-71
35. **Fan M, Long X, Bailey JA, et al.** 2002 The activating enzyme of NEDD8 inhibits steroid receptor function. *Mol Endocrinol* 16:315-30
36. **Denny P, Swift S, Connor F, Ashworth A** 1992 An SRY-related gene expressed during spermatogenesis in the mouse encodes a sequence-specific DNA-binding protein. *Embo J* 11:3705-12
37. **Wang J, Xie LY, Allan S, Beach D, Hannon GJ** 1998 Myc activates telomerase. *Genes Dev* 12:1769-74
38. **Hernandez-Alcoceba R, Pihajla M, Nunez G, Clarke MF** 2001 Evaluation of a new dual-specificity promoter for selective induction of apoptosis in breast cancer cells. *Cancer Gene Ther* 8:298-307
- 420 39. **Silverman E, Eimerl S, Orly J** 1999 CCAAT enhancer-binding protein beta and GATA-4 binding regions within the promoter of the steroidogenic acute regulatory protein (StAR) gene are required for transcription in rat ovarian cells. *J Biol Chem* 274:17987-96
40. **Zhang M, Magit D, Pardee AB, Sager R** 1997 Re-expression of elafin in 21MT2 breast carcinomas by phorbol 12-myristate 13-acetate is mediated by the Ap1 site in the elafin promoter. *Cancer Res* 57:4631-6
41. **Bingle L, Tetley TD, Bingle CD** 2001 Cytokine-mediated induction of the human elafin gene in pulmonary epithelial cells is regulated by nuclear factor-kappaB. *Am J Respir Cell Mol Biol* 25:84-91
42. **Sallenave JM, Shulmann J, Crossley J, Jordana M, Gauldie J** 1994 Regulation of secretory leukocyte proteinase inhibitor (SLPI) and elastase-specific inhibitor (ESI/elafin) in human airway epithelial cells by cytokines and neutrophilic enzymes. *Am J Respir Cell Mol Biol* 11:733-41
- 430 43. **Schalkwijk J, Wiedow O, Hirose S** 1999 The trappin gene family: proteins defined by an N-terminal transglutaminase substrate domain and a C-terminal four-disulphide core. *Biochem J* 340 ( Pt 3):569-77
44. **Hagiwara K, Kikuchi T, Endo Y, et al.** 2003 Mouse SWAM1 and SWAM2 are antibacterial proteins composed of a single whey acidic protein motif. *J Immunol* 170:1973-9
45. **Fathalla MF** 1971 Incessant ovulation--a factor in ovarian neoplasia? *Lancet* 2:163
46. **Huang S, Robinson JB, Deguzman A, Bucana CD, Fidler IJ** 2000 Blockade of nuclear factor-kappaB signaling inhibits angiogenesis and tumorigenicity of human ovarian cancer cells by suppressing expression of vascular endothelial growth factor and interleukin 8. *Cancer Res* 60:5334-9
47. **Garson K, Macdonald E, Dube M, Bao R, Hamilton TC, Vanderhyden BC** 2003 Generation of tumors in transgenic mice expressing the SV40 T antigen under the control of ovarian-specific promoter 1. *J Soc Gynecol Investig* 10:244-50
- 440

## FIGURE LEGENDS

### Figure 1

**A. Creation of pHE4 constructs;** The 2071bp PCR fragment of HE4 was subjected to restriction digestion to yield pHE4-1308, pHE4-799, pHE4-652, and pHE4-395, and fragments were ligated into pGL2-basic luciferase expression vector. The pHE4-1308 construct includes 480 base pairs of the core HE4 promoter region as deduced by CHIP2, and 850bp of HE4 gene. pHE4-799 includes the core promoter region and extends 410bp upstream of the HE4 start site. pHE4-652 contains the core promoter region, an additional 122bp further upstream than the other three  
450 constructs, and extends 78 base pairs after the HE4 ATG start site. pHE4-395 contains a truncated core promoter region lacking the HE4 ATG start site. The double line indicates the unique 122bp upstream in pHE4-652. Arrow represents the beginning of translation of the HE4 gene. The core promoter region spans -407 to + 73 relative to the HE4 translation start site.

**B. Location of transcription binding motifs in pHE4-652;** pHE4-652 contains several known transcriptional regulatory elements: AP1, AP2, AP4, activator protein 1, 2, 4; CMYB, c-Myb; CREB, cAMP-responsive element binding protein; EF1, delta EF1; ER, estrogen receptor; GATA, GATA binding site; GC, GC box elements; IK2, Ikaros 2; MZF1, myeloid zinc finger protein 1; NF1, nuclear factor 1; NFkB, NF-kappaB; NKX25, homeo domain factor/tinman  
460 homolog; RORA, RAR-related orphan receptor; SOX5, SRY-related gene expressed during spermatogenesis; SP1, stimulating protein 1; SRY, sex-determining region Y gene product; TATA, cellular and viral TATA box elements.

## Figure 2

*Optimization of pHE4-652 in NPA Cells;* To allow maximal luciferase activity by pHE4-652 in NPA thyroid cancer cells, the optimal amount of pHE4-652 DNA to use in the this cell line was determined by transfecting 200-1000ng/well of pHE4-652. Total DNA transfected was held constant at 1ug/well using pGEM3z vector. Activity is expressed as relative luciferase (luc/ $\beta$ gal). All cell lines tested underwent this optimization procedure. \* = significant over control TATA-luc, (P < 0.002). Values are shown as the means  $\pm$  SEM.

## Figure 3

*Comparison of HE4 promoters in ovarian cancer cell lines;* The HE4 promoter fragments were compared using transfection assays of ovarian cancer cell lines A2780, SKOV-3, OVCAR-3, and the cervical cancer cell line HeLa. An optimal amount of pHE4-1308, -799, -652, or -395 DNA was transfected into each cell line. Values are shown as average relative luciferase units (RLU; luc/ $\beta$ -gal). Bars represent the mean of three experiments  $\pm$  SEM.

480

## Figure 4

*A. pHE4-652 is active in ovarian cancer cell lines;* Ovarian cancer cell lines (A) and non-ovarian and normal cells (B) were transfected with optimized ng/well pHE4-652 DNA. CMV- $\beta$ gal was cotransfected to control for transfection efficiency. Luciferase activity in each plasmid is given as a percentage of SV40 driven positive control plasmid pGL2-control. TATA-luc was used as a negative control. Values are represented as a percentage of SV40 promoter plus

enhancer driven luciferase activity, and SV40 is normalized to 100%. Results represent the mean of at least three independent experiments. Error bars are  $\pm$ SEM.

490 **B.** *pHE4-652 is not active in non-ovarian and normal cell lines*; pHE4-652 has minimal activity (1-6% SV40) in the non-ovarian cancer cell lines and normal cell lines. Activity was highest (6% SV40) in NHK cells, but not significant over TATA-luc. Activity of all other non-ovarian cancer lines remains below our 5% minimal cutoff.

### **Figure 5**

**A.** *OSP1 exhibits activity in most ovarian cancer cell lines*; Ovarian cancer cell lines (A) and non-ovarian and normal cells (B) were transfected with optimized levels of OSP1 DNA (ng/well). CMV- $\beta$ gal was cotransfected to control for transfection efficiency. Luciferase activity in each plasmid is given as a percentage of SV40 driven positive control plasmid pGL2-control.  
500 TATA-luc was used as a negative control. Values are represented as a percentage of SV40 promoter plus enhancer driven luciferase activity, and SV40 is normalized to 100%. Results represent the mean of at least three independent experiments. Error bars are  $\pm$ SEM.

**B.** *OSP1 also exhibits activity in non-ovarian cancer lines as well as normal ovary*; OSP1 also has considerable activity in the non-ovarian cancer cell line NPA (31% SV40) as well as NHF and NHK (51 and 70% SV40). Moderate activity of OSP1 was observed in normal and immortalized ovarian cell lines nOSE and IOSE (36 and 27% SV40 respectively).

510 **Figure 6**

**A. *hTERT* is active in all ovarian cancer cell lines;** Ovarian cancer cell lines were transfected with optimized *hTERT*-P444 DNA (ng/well). CMV- $\beta$ gal was cotransfected to control for transfection efficiency. Luciferase activity in each plasmid is given as a percentage of SV40 driven positive control plasmid pGL2-control. TATA-luc was used as a negative control. Values are represented as a percentage of SV40 promoter plus enhancer driven luciferase activity, and SV40 is normalized to 100%. Results represent the mean of at least three independent experiments. Error bars are  $\pm$ SEM.

**B. *hTERT* is active in non-ovarian tumor lines and normal cell lines.** Non-ovarian and normal  
520 cells were transfected with optimized *hTERT*-P444 DNA (ng/well) as described in (A). Values are represented as a percentage of SV40 promoter plus enhancer driven luciferase activity, and SV40 is normalized to 100%. Results represent the mean of at least three independent experiments. Error bars are  $\pm$ SEM.

### **Article Précis**

The HE4 promoter drives ovarian cancer specific expression of a reporter gene and deserves consideration for use in ovarian cancer gene therapy.

**Table 1**  
**Optimization of Promoter Constructs in Cell Lines\***

<b>Cell Line</b>	<b>pHE4-652</b>	<b><i>hTERT</i> P-444</b>	<b>OSP-1</b>
<b>A2780</b>	800	800	600
<b>A2780CP</b>	800	800	600
<b>CP70</b>	500	800	1000
<b>HeyC2</b>	400	500	300
<b>SKOV3 &amp; 3X</b>	600	800	800
<b>OVCAR-3</b>	500	700	1000
<b>NPA</b>	300	1000	1000
<b>MCF7</b>	1000	1000	1000
<b>nOSE/IOSE</b>	1000	1000	1000
<b>NHF/NHK</b>	1000	1000	1000

\*All cell lines were optimized with the three constructs being tested; Each promoter construct (pHE4-1308, -799, -652, -395, OSP1, and *hTERT*) were optimized for DNA in ng/well that gave the highest luciferase values for each cell line. Total DNA was kept constant at 1µg/well for all cell lines (0.5µg/well for HeyC2) by addition of the empty vector pGEM3z. CMV-βgal was cotransfected to control for transfection efficiency.

Figure 1A

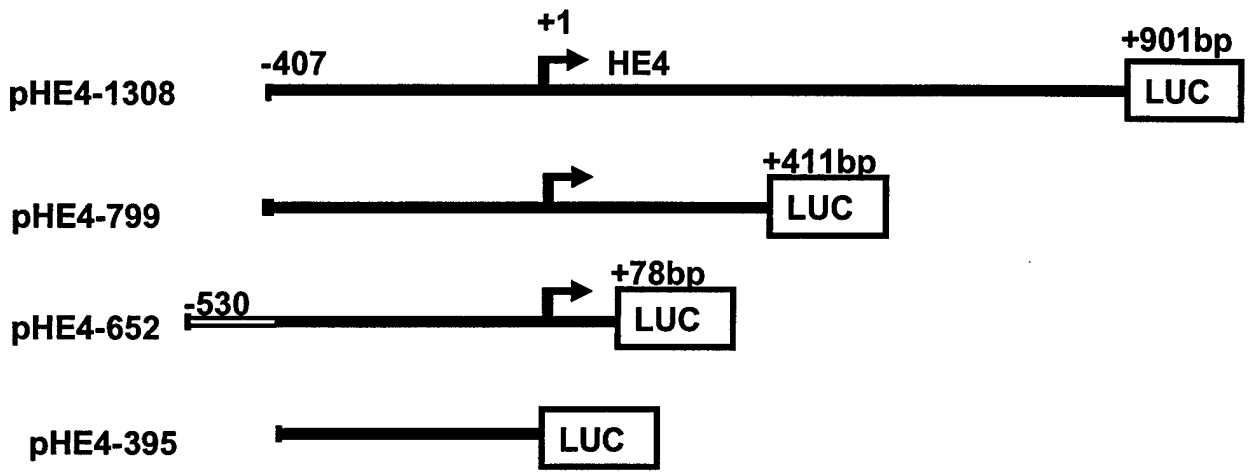

540

FIGURE 1B



**FIGURE 2**

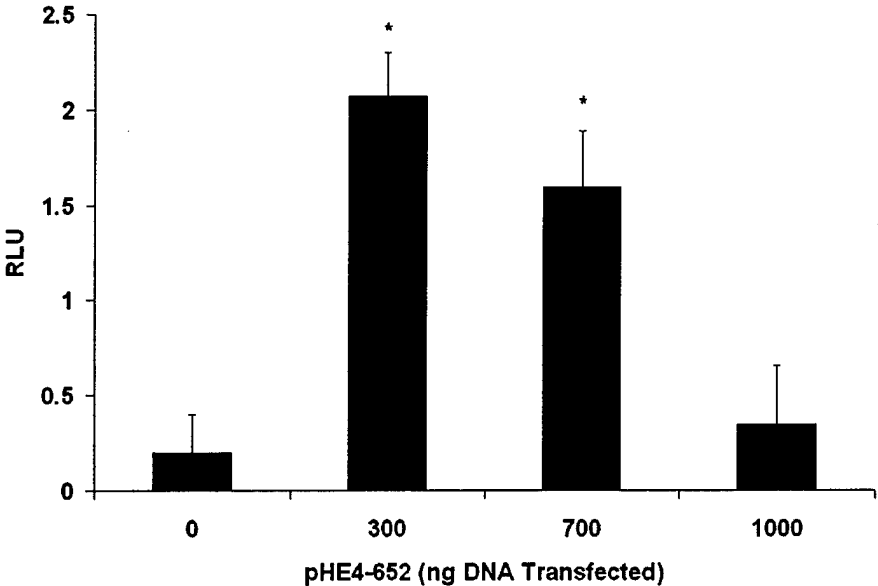

FIGURE 3

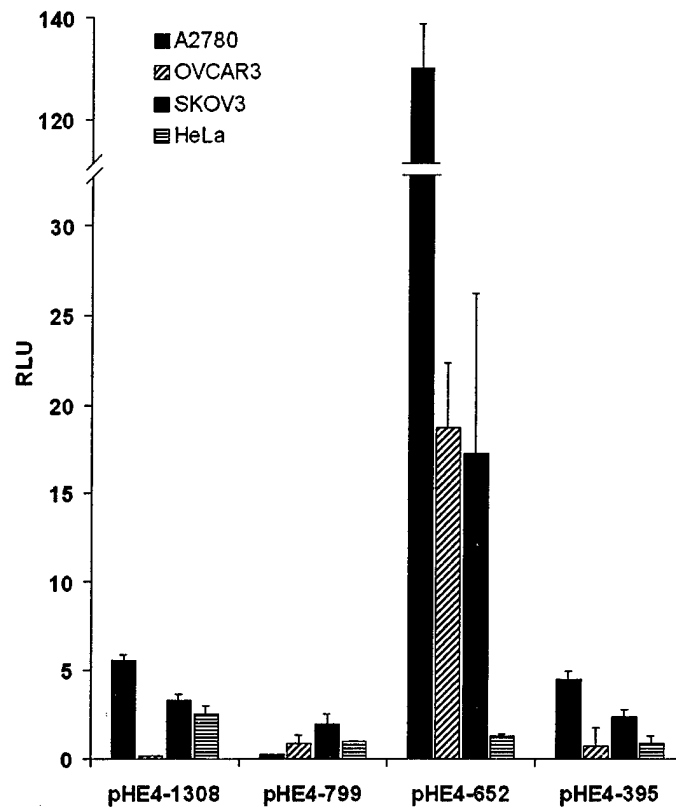

FIGURE 4A

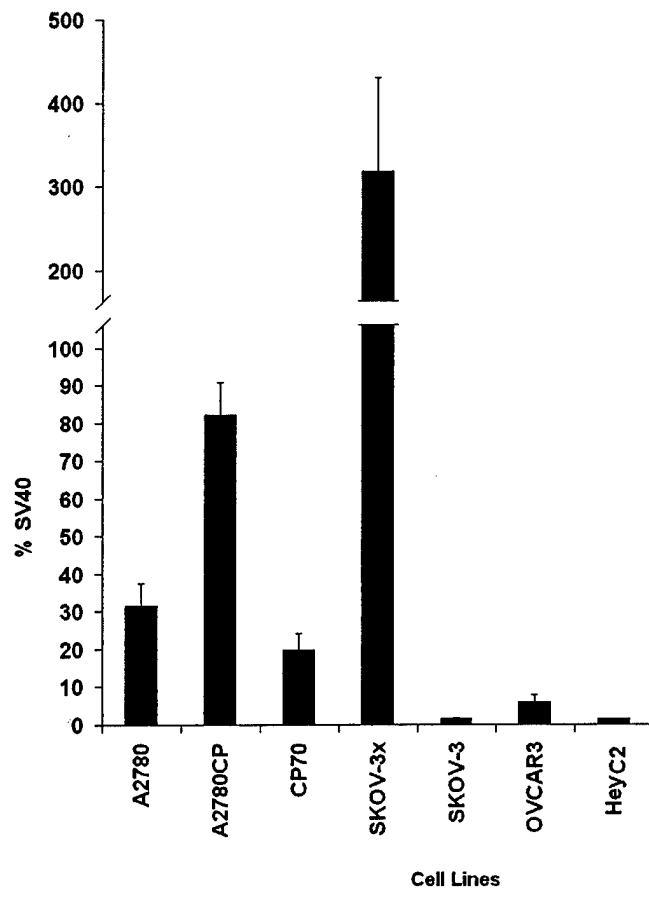

FIGURE 4B

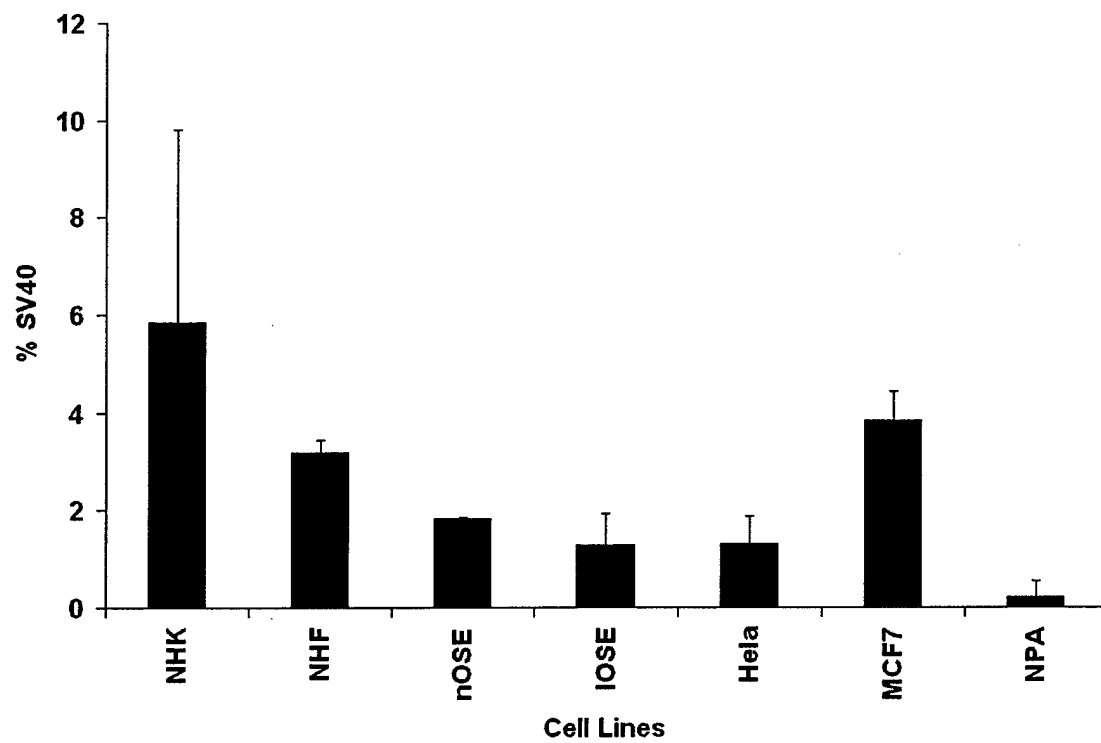
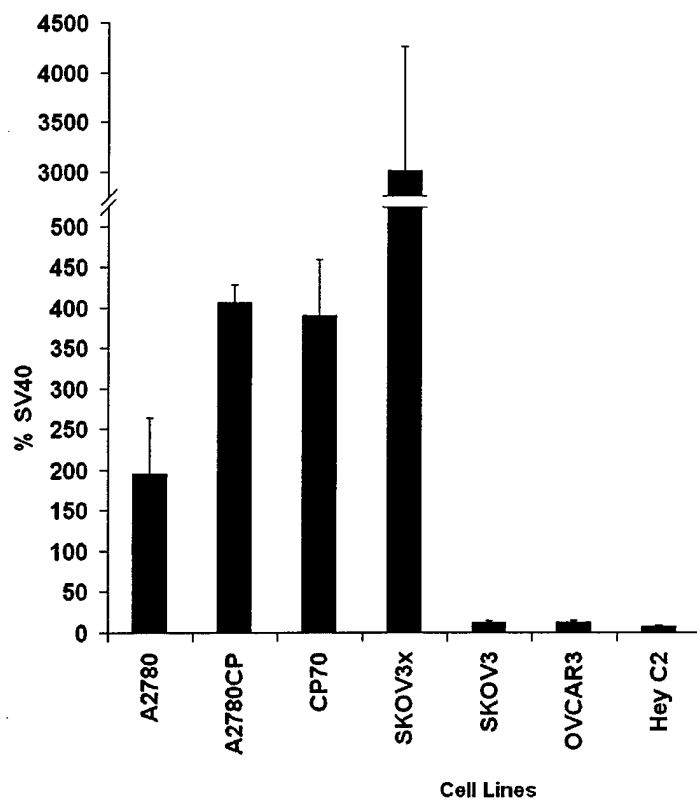

FIGURE 5A



**FIGURE 5B**

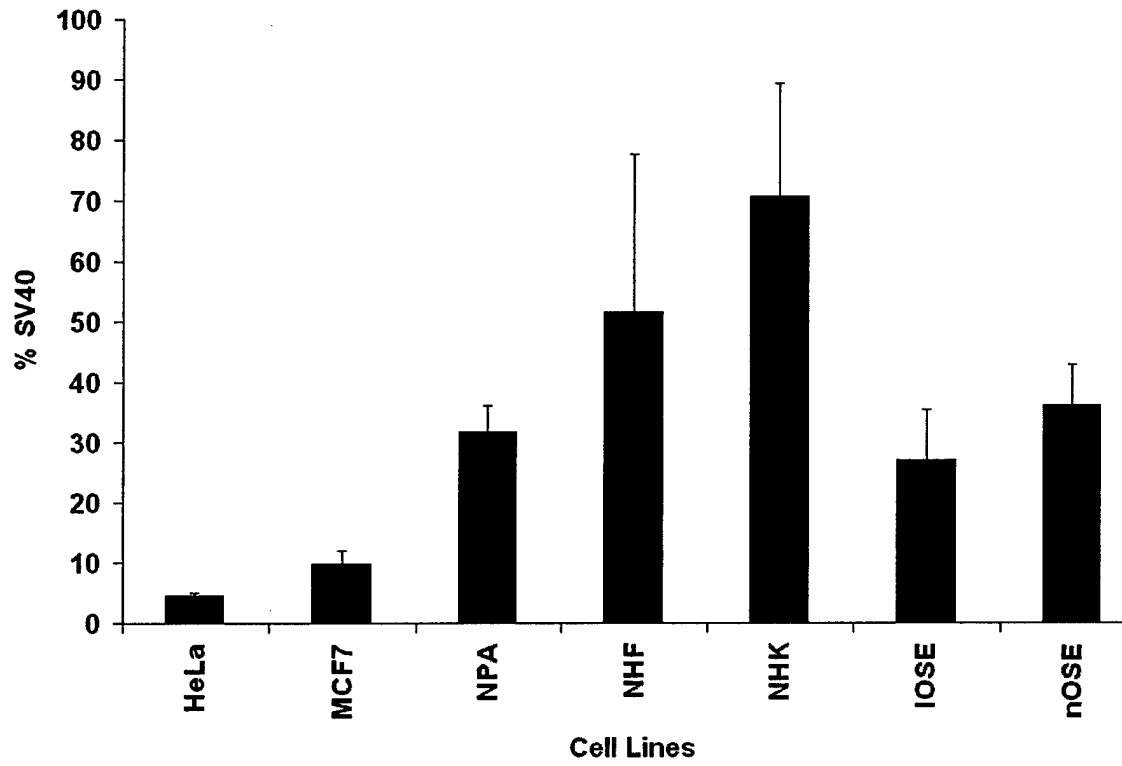

FIGURE 6A

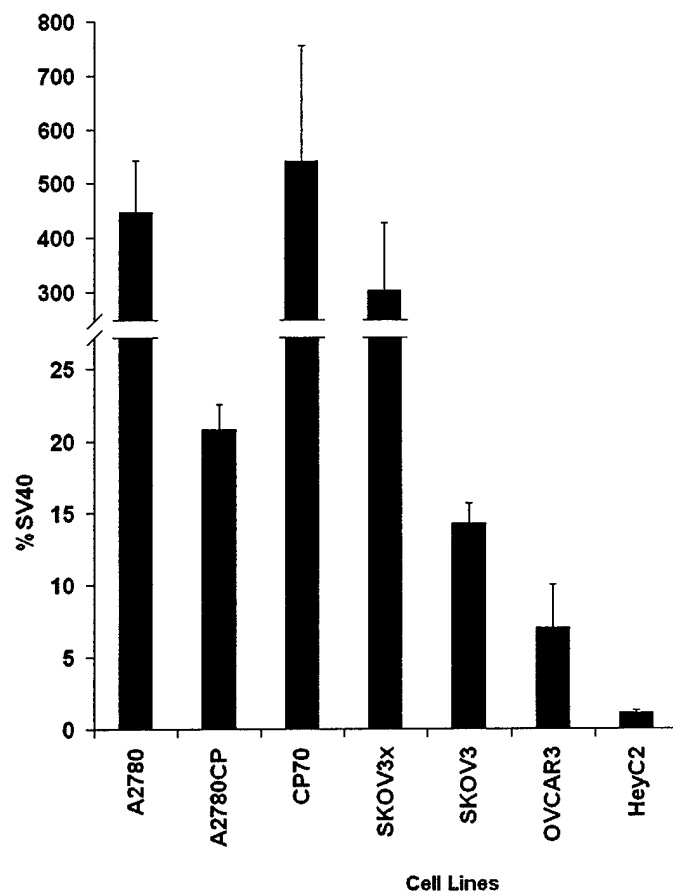

FIGURE 6B

