

UNITED STATES CIVIL DEFENSE

Heavy Duty Rescue Course

IG-14-3 (Instructor's Guide)

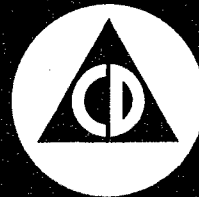

20040316 017

FEDERAL CIVIL DEFENSE ADMINISTRATION

UNITED STATES CIVIL DEFENSE

Heavy Duty Rescue Course

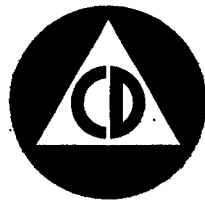

IG-14-3 (Instructor's Guide)

DISTRIBUTION STATEMENT A
Approved for Public Release
Distribution Unlimited

FEDERAL CIVIL DEFENSE ADMINISTRATION

United States Government Printing Office : September 1956

For sale by the Superintendent of Documents, U. S. Government Printing Office
Washington 25, D. C. - Price 35 cents

CONTENTS

	<i>Page</i>
INTRODUCTION	1
SUGGESTIONS TO INSTRUCTOR	2
COURSE OUTLINE	3
LESSON PLANS	
1. Squad organization	5
2. Care and use of truck, tools, and equipment	11
3. Power equipment and truck operation	12
4. Reeving of blocks	17
5. Lashing and rigging	21
6. Care and use of masks	33
7. Breaching walls	36
8. Shoring (part II)	38
9. Trenching, tunneling, and shafting	43
10. Rescue from heights	52
11. Radiological defense instrument familiarization	60
12. Planning for night exercise	65
13. Night exercise	67
14. Critique of exercise	69
TIPS FOR MAINTAINING SQUAD INTEREST IN TRAINING AFTER THE COURSE	71
FILMS	72
REFERENCES	74
Selected FCDA publications	74
Other publications	74

INTRODUCTION

This guide will be of assistance to all instructors, particularly those who have had little teaching experience; however, instructors should have thorough training in the subject matter.

The course Heavy Duty Rescue is eligible for matching funds under the requirements of chapter 7, *Federal Contributions*, FCDA, M25-1, provided:

1. Instructors have satisfactorily completed a heavy duty rescue course and the 10-hour Civil Defense Instructor's Course, No. 3.3, or its equivalent; or
2. Instructors have satisfactorily completed the Heavy Duty Rescue Instructor Training Course as taught at the Federal Civil Defense Administration Rescue Instructor Training School, Olney, Maryland; and
3. Instructors presenting Lesson No. 11, Radiological Defense Instrument Familiarization, meet the qualifications on page 56 of this guide.

This guide in heavy duty rescue includes:

SUGGESTIONS TO INSTRUCTOR
COURSE OUTLINE
LESSON AIDS
LESSON PLANS

SUGGESTIONS TO INSTRUCTOR discusses methods of instruction, training equipment, and facilities.

COURSE OUTLINE gives pertinent information such as: length of time, recommended size of class, and prerequisites.

LESSON AIDS present course material that may be developed and used by the instructor.

LESSON PLANS blueprint the lessons, indicating to the instructor subjects to be covered and order to be followed, and list training materials and references.

SUGGESTIONS TO INSTRUCTOR

The instructor should review *Civil Defense Instructor's Course*, FCDA, IG-3-3, which stresses the importance of the following steps:

1. Introduction.
2. Presentation.
3. Supervision of practice.
4. Testing and followup.

Use of Films

Some good films on rescue are listed on page 72 of this guide. These may be shown at the discretion of the instructor to stimulate the interest of the class or to illustrate teaching points.

Use of Trainee Talents

Many rescue trainees are experts in their fields, and the instructor should use their skills when possible. For example, there may be an experienced oxyacetylene torch man in the class. He could serve as instructor in the use of the oxyacetylene torch in Lesson No. 3. The instructor should go over the material to be presented by such "subject" instructors in advance to make sure all essential points are covered.

Equipment for Training

The equipment listed in Annex 4-B of *Federal Contributions* (Revised 1954), FCDA, M25-1, should be used in this course.

Facilities

The rescue operations training sets listed in chapter 4 of *Federal Contributions* should be used if possible. If this is not feasible, instructors should ask the help of city officials since they know of buildings being dismantled or torn down and may be able to make them available for the course. It is impossible to give training in this course without adequate training facilities.

COURSE OUTLINE

TITLE: Heavy Duty Rescue—Course No. 14.3

TIME: 32 hours

Recommended number of trainees: 26

Recommended for: Men employed in public safety services, skilled workers in industry and building trades, and members of peacetime rescue organizations

Prerequisites: Light Duty Rescue Course No. 14.2

NO.	LESSONS	HOURS
1.	Squad organization	1
2.	Care and use of truck, tools, and equipment	2
3.	Power equipment and truck operation	4
4.	Reeving of blocks	1
5.	Lashing and rigging	5
6.	Care and use of masks	2
7.	Breaching walls	1
8.	Shoring (part II)	2
9.	Trenching, tunneling, and shafting	4
10.	Rescue from heights	3
11.	Radiological defense instrument familiarization	2
12.	Planning for night exercise	1
13.	Night exercise	3
14.	Critique of exercise	1

LESSON AIDS

1—Squad Organization

The civil defense rescue service is responsible for removing injured and uninjured people trapped in wreckage. The lives of these people may depend on the speed and skill of rescue workers. For that reason organization and teamwork are important in rescue.

Squad leaders should know the skills and backgrounds of their squad members to determine what job each can do best in the rescue service. The capability of the squad as a whole will depend, not only on the efficiency of individual workers, but on their integration into the squad, the type and extent of training, and leadership.

LESSON PLAN NO. 1

COURSE: Heavy Duty Rescue—Course No. 14.3

LESSON TITLE: Squad Organization

TIME: 1 hour

TRAINING MATERIALS:

- Blackboard, chalk, eraser.
- Filmstrip projector and screen.
- Filmstrip: "Rescue Squad Operations."

REFERENCES:

- Light Duty Rescue Course*, FCDA, IG-14-2, Lesson Plan No. 1.
- Rescue Techniques and Operations*, FCDA, TM-14-1.

MOTIVATION:

Rescue squad operational procedures should be clearly defined, and all trainees should know the general operational plan. Squad organization should be uniform throughout the country so a squad member trained in California, for example, could work equally well with the rescue service in New York.

MAIN TOPICS	TEACHING POINTS
A. SQUAD ORGANIZATION	Each heavy duty rescue squad should have 26 men: a leader, deputy leader, and 3 teams, each composed of a leader and 7 men.
B. CHAIN OF COMMAND	<ol style="list-style-type: none"> 1. In metropolitan areas the chain of command should go from the chief of rescue at the main control center to the rescue coordinator at each zone, then to the squad leader. 2. Review organization in Light Duty Rescue Course No. 14.2, Lesson Plan No. 1, D. 3. a., b., and c.
C. RESCUE SQUADS REQUIRED	<ol style="list-style-type: none"> 1. In lieu of more exact information from an urban analysis, a quick and relatively accurate estimate of the number of rescue squads required can be made after attack by applying the following formula: $Pr \times Pt \times Za = R$ 2. Review explanation of formula in Light Duty Rescue Course No. 14.2, Lesson Plan No. 1, D. 6. a., b., and c.
D. MISSION	The primary mission of the rescue service is to remove persons trapped in the wreckage of damaged structures, in or under vehicles, and in shelters where exits have been blocked.
E. TACTICAL RESCUE OPERATIONS	<ol style="list-style-type: none"> 1. Heavy duty rescue squads will generally operate in B and C zones of damage. 2. The complexity of rescue operations will depend upon: <ol style="list-style-type: none"> a. Warning time and the extent of evacuation. b. Information to the public. c. Shelters available. d. Type of structures.

MAIN TOPICS	TEACHING POINTS
E. TACTICAL RESCUE OPERATIONS—CON.	<ul style="list-style-type: none"> e. Size of bomb. f. Weather conditions, particularly those causing serious radiological hazards. <p>3. The estimated time required for one heavy duty rescue is 20 man-hours, as against 2 for one light duty rescue.</p>
F. SQUAD PERSONNEL	<ul style="list-style-type: none"> 1. Squad members should be men used to working with their hands, for example: carpenters, mechanics, riggers, equipment operators, truck drivers, and maintenance men. Public safety services, building trades, industrial plants, and peacetime rescue organizations are good sources of such manpower. 2. Squad members must be willing to contribute the time required for training and practice. 3. Squad and team leaders should understand and command the respect of their men. They should be capable of sound judgment and quick decisions.
G. TRAINING PROGRAM	<ul style="list-style-type: none"> 1. To develop efficiency, individually and as members of a team and squad, rescue personnel must be thoroughly trained in approved rescue skills and techniques. 2. Practice sessions and refresher drills should be held on a continuing basis after initial training to develop and maintain confidence and trust between members and leaders. 3. All civil defense rescue training should be standardized because: <ul style="list-style-type: none"> a. Squads may have to operate outside their own communities as a part of mobile support. b. Squads may have to work with or as part of other rescue service units. 4. Drills and exercises should be held periodically with other civil defense services, such as fire and health.
H. FACILITIES	<p>Many communities have erected facilities similar to those of The FCDA Rescue Instructor Training School in Olney, Maryland. These provide realism to rescue training and promote local interest in the rescue service.</p>

STUDENT PARTICIPATION:

Questions and answers.

HANDOUT MATERIALS AVAILABLE:

None.

LESSON AIDS

2—Care and Use of Truck, Tools and Equipment

3—Power Equipment and Truck Operation

Rescue trucks, tools, and equipment are only as good as the men who use them. Squad members *must* know how and when to use each piece of equipment and its exact location on the truck. They should also know how to drive the truck because the regular driver may not always be present.

For instruction, equipment may be divided into the following classifications: portable units, portable electric tools, metal cutting tools, oxyacetylene torch, and rescue truck and winch.

The "county fair" method has proved successful in this type of instruction. In this method the class is divided into groups, each group assigned to a "station" with an instructor who explains and demonstrates one classification of equipment. At the end of a given time each group moves on to the next station to study the equipment located there. This rotation method is repeated until all groups have been instructed at all stations.

Five stations could be used for this lesson. They should be spaced far enough apart that the activity of one will not interfere with that of another.

Truck

1. Carries a crew of eight heavy duty rescue personnel.
2. Carries tools and equipment in compartments, grouped according to operational use.
3. Has space for two stretcher casualties.
4. Detailed features are contained in Lesson Plan No. 3.
5. FCDA Standard Item Specification for truck: VIII-140; for truck with equipment and tools VIII-109.
6. Trucks and equipment that meet Federal specifications are eligible as organizational equipment for matching funds under the Federal Contributions Program.

Tools and Equipment

1. Approximate weight—2,400 pounds.
2. Tools—by categories:
 - a. Lifting and rigging equipment: jacks, levers, block and tackle, rope, and winch.
 - b. Digging and moving equipment: picks, shovels, and bars.
 - c. Shoring and blocking equipment: bars, hatchets, saws, and hammers.
 - d. Utility equipment: cutters, pliers, hammers, and wrenches.
 - e. Access equipment: ladders, bars, axes, oxyacetylene cutting outfit, and saws.
 - f. Safety and emergency equipment: gas masks, helmets, lights, goggles, and pumps.
 - g. Power equipment: portable generator, chain saw, circular saw, and winch.
 - h. Casualty handling and first aid equipment: blankets, stretchers, and first aid belt.
 - i. Miscellaneous equipment: rubber boots, raincoat, gloves, safety cans, tarpaulins, and cooking stove.

Organizational Heavy Duty Rescue Equipment

CD ITEM NUMBER	DESCRIPTION	QUANTITY PER SET
<i>Detailed Listing of Tools and Equipment</i>		
VIII-1	Apparatus, self-contained, breathing, with 3 canisters	2
VIII-2	Axes, 4-pound, single bit, with handles	2
VIII-5	Bags, burlap, 60-pound capacity, sand	48
VIII-4	Bands, webbing, for casualty handling	sets 2
VIII-6	Bars, pinch, 30 inches long	1
VIII-7	Bars, wrecking, 1-inch gooseneck, claw and pinch point, 30 inches long	2
VIII-10	Bits, 1 inch auger	2
VIII-11	Blankets, asbestos, protective with canvas container	1
VIII-12	Blankets (cotton and wool)	8
VIII-13	Boots, rubber, pullover, shoe, short, U. S. Rubber or equal (pair)	8
VIII-14	Brace, ratchet head	1
VIII-15	Buckets, galvanized, 14-quart (heavy gage)	6
VIII-16	Can, safety, gasoline, 1-gallon	1
VIII-17	Canteens, without cup	8
VIII-18	Chains, 6 feet long, 15-hundredweight	2
VIII-19	Chains, 6 feet long, 2-ton	1
VIII-20	Chisels, hand, stone (bull) points $\frac{3}{4}$ inch x 9 inch	2
VIII-21	Chisels, hand, cold, 12-inch length	2
VIII-22	Chisels, hand, stone (bull) points 1" x 12"	2
VIII-25	Coats, rain, jacket, medium length	8
VIII-26	Container, debris, bucket type	8
VIII-27	Container, water, drinking, 5-gallon capacity	1
VIII-112	Container, gas, safety, 5-gallon capacity	1
VIII-125	Cord, extension, 100-foot, for floodlights, with twist lock waterproof connectors	5
VIII-126	Cord, extension, 50-foot, for floodlights, with connectors	2
VIII-28	Cord, sash, cotton braided, 15-feet long	8
VIII-29	Coveralls, 4 medium and 4 large	8
VIII-31	Crayon, lumber marking, red, yellow	12
VIII-32	Crowbar, 66-inch length, with chisel	2
VIII-33	Crowbar, 72-inch long, 1½ hexagon handle, with mushroom and flat ends	2
VIII-34	Cutter, bolt, 36-inch long, $\frac{5}{8}$ -inch	1
VIII-113	Cutter, pipe, $\frac{1}{8}$ - to 2-inches, 3-wheel type	1
VIII-40	Gear, lifting tackle, 1½-ton capacity	1
VIII-41	Gloves, heavy debris (pair)	16
VIII-42	Gloves, rubber, insulating (pair)	2
VIII-44	Goggles, dustproof, shatterproof	8
VIII-45	Hacksaw, frame, with 10 blades	1
VIII-46	Hammers, claw, 16-ounce, with handle	4
VIII-139	Hammers, cross-peen 3-pound, with handle	2
VIII-47	Hammers, sledge, 4-pound, with handle	2
VIII-48	Hammers, sledge, 8-pound, with handle	2
VIII-49	Hammers, sledge, 16-pound, with handle	1
VIII-116	Hatchet, carpenter's	2
VIII-103	Heater, unit, single-burner, pressure type, gas-burning for boiling water	1
VIII-50	Helmet, protective, without lighting bracket	8
VIII-51	Jacks, ratchet, 5-ton capacity, with lever	2

Detailed Listing of Tools and Equipment

VIII-52	Jacks, ratchet, 15-ton capacity, with lever.....	2
VIII-53	Jacks, screw, 5-ton capacity.....	2
VIII-38	Kit, first aid, belt type, with 8 refills in separate container.....	8
VIII-56	Ladder, roof, 12-foot, with folding hooks.....	1
VIII-57	Ladder, extension 28-foot, 2-section.....	1
VIII-117	Ladder, collapsible, 10-foot.....	1
VIII-59	Lights, flood, portable, generator powered.....	3
VIII-119	Lights, red-flashing, battery powered.....	4
VIII-67	Lights, safety approved, with battery.....	8
VIII-114	Mask, gas, filter type, with canister.....	4
VIII-66	Outfits, cutting, oxygen-acetylene, with goggles and gloves, 2 spare oxygen tanks, 1 spare acetylene tank.....	1
VIII-68	Pick, point and chisel, with handle.....	2
VIII-69	Pick, poll or mining, with handle.....	2
VIII-70	Pliers, 8-inch combination, slip joint, with cutter.....	4
VIII-71	Pliers, 8-inch, electric, wire-cutting, with insulated handle.....	1
VIII-118	Pole, pike, 8-foot.....	1
VIII-72	Power unit, gas, drive, 2½ kilowatt, portable, AC.....	1
VIII-73	Pumps, stirrup, with 20-foot hose and jet nozzle.....	1
VIII-80	Rope, manila, ½-inch diameter, 50-foot lengths.....	8
VIII-141	Rope, manila, ½-inch diameter, 150-foot lengths.....	4
VIII-81	Rope, manila, ¾-inch diameter, 200-foot lengths.....	1
VIII-82	Rope, manila, ¾-inch diameter, 300-foot lengths.....	1
VIII-142	Rope, manila, 1-inch diameter, 300-foot lengths.....	1
VIII-77	Rope, wire, ¼-inch diameter, 15-foot lengths, with capped and eye ends for lashings.....	6
VIII-78	Rope, wire, ¾-inch diameter, 10-foot lengths, with shackle and eye ends.....	2
VIII-79	Rope, wire, ¾-inch diameter, 50-foot lengths with hook and eye.....	2
VIII-129	Rule, folding, carpenter's, wood, 6-foot.....	1
VIII-84	Saw, chain, electric, 18-inch with extra chain.....	1
VIII-85	Saw, crosscut, 4½-foot blade.....	1
VIII-121	Saw, floor, silver steel, 10-point, 18-inch long.....	1
VIII-86	Saw, hand, 26-inch cutting edge.....	1
VIII-122	Saw, power, electric, portable, 8-inch, with case.....	1
	Blades:	
	Combination, 2.	
	Nailcutting, 2.	
	Carboly, 2.	
VIII-87	Saw, pruning, double edge, 18-inch blade.....	1
VIII-88	Screwdriver, common, 16½-inch.....	1
VIII-123	Shears, tinnerns, 12-inch (snips).....	1
VIII-89	Sheeting, rubber, black, 45-inch wide, 84-inch long.....	8
VIII-90	Shovel, round, pointed, long handle.....	2
VIII-91	Shovel, square mouth, D-handle.....	2
VIII-92	Shovels, tunnelling, short D-handle, 18-inch long.....	2
VIII-94	Stakes, metal, 30-inch long, 1-inch diameter.....	8
VIII-95	Stretchers, latest Army type (canvas).....	4
VIII-124	Stretchers, Stokes type.....	1

CD ITEM
NUMBER

DESCRIPTION

QUANTITY
PER SET

Detailed Listing of Tools and Equipment

VIII-144	Tackle block, manila rope, 8-inch (snatch)-----	1
VIII-96	Tackle block, manila rope, 6-inch (2-sheave)-----	2
VIII-97	Tackle block, manila rope, 6-inch (3-sheave)-----	2
VIII-98	Tackle block, manila rope, 6-inch single-sheave snatch-----	2
VIII-143	Tackle block, manila rope, 4-inch (2-sheave)-----	8
VIII-147	Tackle block, 5/8-inch wire rope (single snatch)-----	2
VIII-101	Telephone set, self-energizing, with 400 feet of wire, complete-----	1
VIII-137	Tape, 50-foot, metallic, graduated in inches and sixteenths-----	1
VIII-102	Tarpaulin, 8- by 10-foot-----	1
VIII-107	Wrenches, pipe, 24-inch, Stillson-----	2
VIII-108	Wrenches, adjustable, crescent. 12-inch-----	1

LESSON PLAN NO. 2

COURSE: Heavy Duty Rescue—Course No. 14.3

LESSON TITLE: Care and Use of Truck, Tools, and Equipment

TIME: 2 hours

TRAINING MATERIALS:

Fully equipped heavy duty rescue truck.

REFERENCES:

Rescue Techniques and Operations, FCDA, TM-14-1, chapter 2.

Federal Contributions, FCDA, M25-1, Revised 1954, Annex 4-B.

Instructional material from vehicle and equipment manufacturers.

MOTIVATION:

Tools and equipment will be needed in a hurry during operations, and squad members must know where they are stored on the truck. Even among the best organized squads, however, some confusion must be expected.

MAIN TOPICS	TEACHING POINTS
A. TRUCK	Explanation of truck by instructor, covering, size, weight, horsepower, make, cost, and Federal contributions program.
B. EQUIPMENT	Explanation by instructor of general types of equipment, cost, and Federal contributions program.
C. INSPECTION OF TRUCK AND EQUIPMENT	Instructor should let the class examine the truck inside and out, including compartments where equipment is stored. He should not go into too much detail at this point.
D. REMOVAL OF EQUIPMENT	Instructor should have the class remove all tools and equipment from the truck. Class should clean each piece of equipment and oil, if necessary. Instructor should inspect results.
E. REPLACEMENT OF EQUIPMENT	Trainees should replace each piece of equipment in its proper compartment. Team leaders should check off the equipment to make sure none is missing.

STUDENT PARTICIPATION:

Instructor should encourage class members to ask questions while examining equipment.

HANDOUT MATERIALS AVAILABLE:

Equipment list should be reproduced and used as a handout.

Instructor should contact manufacturer for descriptive pamphlets on truck and equipment.

LESSON PLAN NO. 3

COURSE: Heavy Duty Rescue—Course No. 14.3

LESSON TITLE: Power Equipment and Truck Operation

TIME: 4 hours

TRAINING MATERIALS:

- Equipment on rescue truck.
- Two gallons of regular gasoline.
- One quart of motor oil.
- Two saw horses.
- Scrap lumber and poles for cutting.
- Scrap iron for cutting.
- Fire extinguisher.
- Filmstrip projector and screen.
- Filmstrip: "Rescue Tools and Techniques."

REFERENCES:

- Rescue Techniques and Operations*, FCDA, TM-14-1.
- Manufacturers' instruction booklets.

MOTIVATION:

Power equipment is necessary in heavy duty rescue, but it can be dangerous if handled incorrectly. Every squad member *must* know how to use power tools.

MAIN TOPICS	TEACHING POINTS
A. PROCEDURE	<ol style="list-style-type: none"> 1. Explanation and demonstration of truck by instructor (1 hour). 2. Explanation and demonstration of oxyacetylene torch by instructor (30 minutes). 3. "County fair" method using 5 stations, 1 group at each station, and rotating to next station after 30 minutes (2½ hours). <ol style="list-style-type: none"> a. Station I (30 minutes). Generator, power cable, lights, and self-energizing telephone. b. Station II (30 minutes). Electric chain saw and electric circular saw. c. Station III (30 minutes). Pipe cutters, pipe wrenches, bolt cutters, and gear-lifting tackle. d. Station IV (30 minutes). Oxyacetylene torch. e. Station V (30 minutes). Winch operation.
B. TRUCK (4 x 2)	<ol style="list-style-type: none"> 1. Rescue truck can be used as: <ol style="list-style-type: none"> a. A base for preattack rescue operations training. b. A base for rescue operations in an emergency. c. A mobile unit for mobile support operations in an emergency. 2. General description of chassis: <ol style="list-style-type: none"> a. Truck chassis—4 x 2. b. Gross vehicle weight—20,000 pounds. c. Wheel base—150 to 160 inches. d. Gear ratio—nearest to 6.67/8.85-1.

MAIN TOPICS	TEACHING POINTS
	<ul style="list-style-type: none"> e. Gradability—computed on the mean of the two ratios which are not less than 3.5 percent in direct drive. f. Generator—heavy-duty, 6-volt (50-ampere output). g. Transmission—5 speeds forward—direct drive in fifth gear and one reverse. h. Auxiliary springs. i. Shock absorbers on front axle. j. Winch—15,000-pound capacity—front end mounted—2 speeds forward and 1 reverse—150 feet of ½-inch cable and hook. Controls in cab. k. Tires—9.00 x 20/10-ply, single front, dual rear—spare tire mounted in rear below frame on crank control carriers and furnished with chassis. l. Gasoline tank—30-gallon minimum. <p>3. General description of body: The all-steel body contains 100 separate items of tools and equipment varying from small hand tools to power equipment, such as a generator and power saws—a total of some 300 pieces. Tools and other rescue equipment are grouped and compartmented according to their family and operational use. Entire panels of allied small tools can be removed from the truck and carried where they are needed. Truck has space for heavy duty rescue team of 8 men.</p> <p>4. Although 1 member of the squad may be designated the driver, all members should know how to drive the truck. Before completing the course they should practice driving under supervision of the instructor.</p> <p>5. All trainees should know the compartments of the truck. (For additional details about the truck, the instructor should read M6-1, FCDA Standard Item Specification No. VIII-140.)</p>
C. WINCH	<ul style="list-style-type: none"> 1. Instructor should explain the mechanism of the winch, stressing caution rules, and be sure all trainees know how to use it. 2. Points to stress: <ul style="list-style-type: none"> a. Uses. b. Mechanism. c. Engagement. d. Disengagement. e. Signals. f. Mechanical advantage. g. Maintenance.
D. PORTABLE GENERATOR	<ul style="list-style-type: none"> 1. Description: <ul style="list-style-type: none"> a. 2½-kilowatts, portable, gasoline powered, 115-volt AC, 60-cycle, single-phase, with a capacity of 2,500 watts. b. Instructor should read carefully the manufacturers' instruction booklet covering: nomenclature, fuel mixture, starting engine, stopping engine, rules for using current, and rules for care and maintenance. c. Instructor should require each trainee to start and stop the engine and go through the nomenclature of the generator.

MAIN TOPICS	TEACHING POINTS
E. PORTABLE ELECTRIC CHAIN SAW	<ol style="list-style-type: none"> 1. Description: <ol style="list-style-type: none"> a. 1-man electric chain saw. b. 115-volt, 60-cycle motor. c. 18-inch capacity. d. Instructor should read the manufacturer's booklets for proper nomenclature. 2. Operation: <ol style="list-style-type: none"> a. Instructor should demonstrate proper method of handling, turning on motor, turning off motor, and maintenance. b. Instructor should require each trainee to use the saw and explain how it operates. 3. Discussion of what not to do.
F. ELECTRIC CIRCULAR SAW	<ol style="list-style-type: none"> 1. Description: <ol style="list-style-type: none"> a. Electrically operated. b. Equipped with automatic release switch and safety guard. c. Interchangeable blades available. <ol style="list-style-type: none"> (1) Combination blade is fast-cutting, for general ripping and cross-cutting in all kinds of wood. (2) Nailcutting blade is for wood which may contain nails. (3) Carboloy blade is for cutting masonry. d. Instructor should read carefully the manufacturer's instruction booklet. Parts should be referred to in correct terminology. 2. Operation: Instructor should demonstrate steps in operating the saw, emphasizing safety precautions. 3. Maintenance: <ol style="list-style-type: none"> a. Motor failure. b. Lubrication. c. Care of blades. d. Trainees should operate saw and explain maintenance.
G. OXYACETYLENE BACK-PACK CUTTING UNIT	<ol style="list-style-type: none"> 1. Description: Instructor should identify items making up the unit, using correct nomenclature: <ol style="list-style-type: none"> a. Carrying pack and its uses. b. Oxygen and acetylene cylinders. c. Valves. d. Hose couplings—threads. 2. Lighting and adjusting flame: <ol style="list-style-type: none"> a. Need for goggles. b. Special gloves. c. Instructor should demonstrate steps, using manufacturer's instruction booklet. 3. Caution rules.

MAIN TOPICS	TEACHING POINTS
G. OXYACETYLENE BACK-PACK CUT- TING UNIT—CON.	<ol style="list-style-type: none"> 4. Cutting: <ol style="list-style-type: none"> a. How to cut metal: <ol style="list-style-type: none"> (1) Instructor should demonstrate. b. Types of metal <i>not to cut</i>. c. Shutting off and storage. 5. Instructors should emphasize again the precautions and call on trainees to name them. 6. Trainees should put the cutter into operation and do some cutting under supervision of the instructor.

STUDENT PARTICIPATION:

All trainees should operate all the power equipment items under careful supervision of the instructor.

HANDOUT MATERIALS AVAILABLE :

Instructor should contact the manufacturers of these items for descriptive pamphlets for class members.

LESSON AIDS

4—Reeving of Blocks

Pulleys and blocks are used in rescue work to:

1. Gain power.
2. Change the direction of a rope to allow sufficient room for squad members to work with the rope.

A single block comprises an outer casing or shell containing a sheave or pulley wheel running on a pin. Double blocks have 2 sheaves side by side; triple blocks have 3 sheaves.

A block is made up of several parts. Rescue workers should learn the names and functions of these parts:

1. *Shell*—the frame of the block. It may be made of wood, iron, or steel. Within the shell are pulleys called sheaves, usually made of steel. The outside surface of the sheave, over which the rope passes, is concave to keep the rope in place. The sheave rotates on a sheave pin which passes through both sides of the shell.

2. *Bushing*—some sheaves have a bushing in the center to keep them working freely. Some are supplied with roller bearings to reduce friction to a minimum. The reduction of friction is important when lifting very heavy loads.

3. *Outside strap*—affixed to the shell and extending from the top is the outside strap to which a hook is fastened. In a wood block, this strap passes down through the shell so the sheave pin can pass through it, thus placing the load on the strap and pin and not on the shell.

4. *Becket*—in every combination of more than one block, one end of the rope must be tied to one end of the blocks. Therefore, one of the blocks must be supplied with a becket which is a concave ring supported on a becket bolt.

5. *Hook*—so designed that, if a load is applied at the lowest point of curvature, it will start to open at approximately 70% of its maximum load. This acts as a warning against overstressing before complete failure. Some hooks have a built-in safety device.

The instructor should insist on frequent inspections of the tackle blocks for defects.

Reeving of blocks is not difficult if the steps outlined in this lesson plan are followed. The instructor should insist on proficiency.

LESSON PLAN NO. 4

COURSE: Heavy Duty Rescue—Course No. 14.3

LESSON TITLE: Reeving of Blocks

TIME: 1 hour

TRAINING MATERIALS:

- Two sets of blocks (3- and 2-combination with beekets).
- One snatch block.
- One 3/4-inch by 100-foot rope.
- Marline or twine for mousing.

REFERENCE:

Rescue Techniques and Operations, FCDA, TM-14-1.

MOTIVATION:

This lesson teaches a skill which must be mastered before attempting to erect a rigging. Without a proper knowledge of the block and tackle, the different types of rigging are as useless as an automobile without a motor.

MAIN TOPICS	TEACHING POINTS
<p>A. TERMS</p>	<p>1. <i>Block</i>—pulley in a shell.</p> <div style="text-align: center;"> </div> <p style="text-align: center;">FIGURE 1.—Pulley in a shell.</p> <p>2. <i>Tackle</i>—consists of two properly reeved blocks. Used for hoisting, lowering, or moving heavy objects. It is designed to give considerable mechanical advantage. The total rope "falls" which leave the movable block determine the mechanical advantage ratio.</p> <p>3. <i>Sheave</i>—grooved pulley.</p> <p>4. <i>Shell</i>—frame.</p> <p>5. <i>Strap</i>—metal strap to which hook is attached.</p>

MAIN TOPICS

TEACHING POINTS

A. TERMS—Continued

6. *Thimble*—part of block to which end of rope is attached.
7. *Standing block*—fixed block in tackle.
8. *Running block*—block attached to object to be moved.
9. *Overhauling blocks*—spreading blocks in tackle.
10. "*Chock-a-block*"—bringing blocks as close together as possible.
11. "*Reeving the block*"—passing the rope over the sheaves in proper order to prepare the blocks for use.
12. *Returns*—parts of rope between blocks.
13. *Standing end*—fixed end of rope in tackle.
14. *Running end*—pull end of rope in tackle.
15. *Snatch block*—single block with opening and locking devices on side to insert rope, generally used to achieve change of direction.

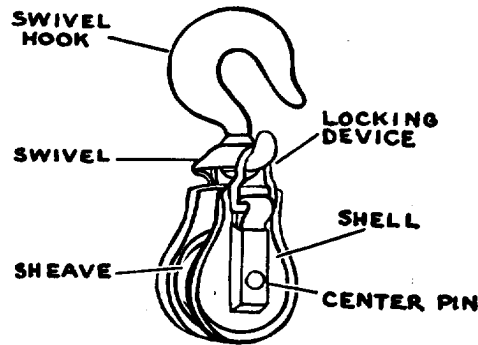

FIGURE 2.—Snatch block.

B. USES FOR BLOCK AND TACKLE

1. Raise and lower heavy objects.
2. To pull objects horizontally.
3. To provide mechanical advantage.

C. MECHANICAL ADVANTAGE (POWER GAIN)

1. Effort required to raise a load is equal to the load divided by the number of ropes leaving the movable block (ignoring friction loss).
 Example: How much effort is required on the pull line of a 3- and 2-combination tackle to raise a load of 500 pounds (exclusive of friction loss)?
 Load equals 500 pounds. Mechanical advantage equals 5. Effort will be $\frac{500}{5}$ equals 100 pounds.
 From the result the rescue leader knows the number of men required on the pull line.

D. REEVING

1. Double and double.
 - a. Lay blocks about three feet apart, hooks out, so one is horizontal and the other vertical (see figure 3).
 - b. To reeve, follow sequence in figure 3.

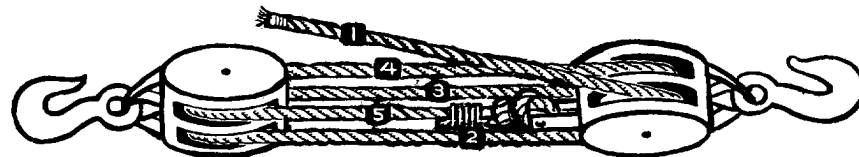

FIGURE 3.—Reeving—double and double.

- c. Complete steps in figure 3.
- d. Secure to becket.

MAIN TOPICS

TEACHING POINTS

2. Triple and double.
 - a. Lay blocks on bench so one is horizontal and the other vertical, hooks out.
 - b. Pass rope through center sheave of standing block (triple).
 - c. Complete steps in figure 4.

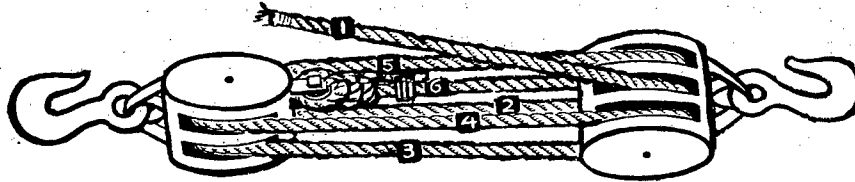

FIGURE 4.—Reeveing—triple and double.

- d. Finish by tying becket with two half-hitches—mouse tail of rope.
3. Triple and triple.

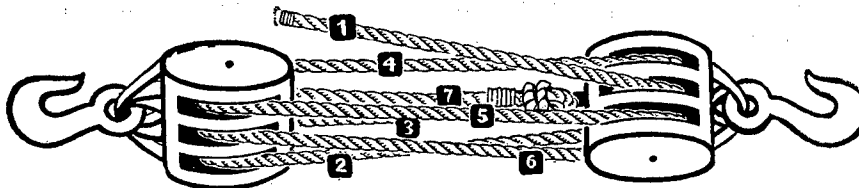

FIGURE 5.—Reeveing—triple and triple.

E. MOUSING OF HOOK

- a. Lay blocks and follow numbered steps in figure 5.
1. A piece of cord (preferably marline) should be tied across the jaws of a hook to prevent a rope or sling from jumping out when the weight surges or is temporarily supported.

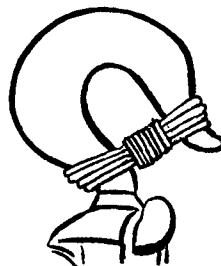

FIGURE 6.—Mousing of hook.

2. Frapping turns should be secured by a square knot.
 3. All hooks should be moused.

STUDENT PARTICIPATION:

Trainees should do reeveing of the three combinations discussed in this lesson plan. They should practice until they are able to do reeveing blindfolded.

HANDOUT MATERIALS AVAILABLE:

Instructor should contact rope manufacturing companies for pamphlets on reeveing.

LESSON AIDS

5—Lashing and Rigging

Four stations should be set up, each with its own instructor, equipment, and training materials. The latter should be laid out in advance. (See training materials list.) Stations should be far enough apart to avoid confusion and competition between groups.

The stations should be numbered consecutively. The class should be divided into four groups, also numbered consecutively. Each group should start at the corresponding numbered station. With five hours allotted to the entire subject of lashing and rigging, approximately 1¼ hours can be devoted to each specific topic by this method. All groups should finish at the same time and move on to the next station.

Each instructor should stay with his group through the four stations. This method insures that one instructor will not rely on another to give details which he should cover, and also lessens the possibility of repetition of some of the techniques common to all phases.

Lashing and rigging is an important phase of rescue instruction. It should not be rushed. Instructors should give class members an opportunity to do different parts of the process, stressing practice to gain proficiency.

LESSON PLAN NO. 5

COURSE: Heavy Duty Rescue—Course 14.3

LESSON TITLE: Lashing and Rigging

TIME: 5 hours

TRAINING MATERIALS:

	<p>One sturdy pole or heavy timber (6'' x 6'' x 18'). One 2'' x 4'' x 30'' (ledger or header). Two 3/4'' x 300' ropes (guy lines). Two 1/2'' x 50' lashing lines. Sling.</p>
Gin Pole.....	<p>(One set block and tackle. Snatch block. Two sets luffing tackle. Marline or twine for mousing. Pry bar—13 iron stakes (holdfasts). Shovel. Miniature model (optional). Two poles or timbers at least 4'' x 4'' x 18'. Two pieces 2'' x 4'' x 6'' (spacers). Two 1/2'' x 50' lashing ropes. Sling.</p>
Sheerlegs.....	<p>One 3/4'' x 300' rope (guy lines). One set block and tackle. Eight iron stakes (holdfasts). Two sets luffing tackle. One snatch block. Shovel. Marline or twine for mousing. Miniature model (optional). Three poles or timbers at least 4'' x 4'' x 18'. Four pieces 2'' x 4'' x 6'' (spacers). One set block and tackle. One snatch block.</p>
Tripod.....	<p>Three 1/2'' x 50' lashing ropes. Shovel. Marline or twine for mousing. Miniature model (optional). One pole or timber, 4'' x 4'' (8' to 16' long). One set block and tackle.</p>
Jib Arm.....	<p>Three 1/2'' x 50' lashing ropes. Marline or twine for mousing. Miniature model (optional.)</p>

REFERENCE:

Rescue Techniques and Operations, FCDA, TM-14-1.

MOTIVATION:

Rescue workers must sometimes move relatively heavy loads horizontally as well as vertically. This operation, which is called "drifting," is easily done by means of blocks and tackle supported by an *A-frame*. The *tripod* is easily assembled and erected to lift a vertical load where there are no structures immediately above to which blocks may be secured. The *gin pole* permits movement of the lifted load in any horizontal direction. The *jib* is frequently used in rescue to lower casualties.

MAIN TOPICS	TEACHING POINTS
-------------	-----------------

GIN POLE

Also called standing derrick.

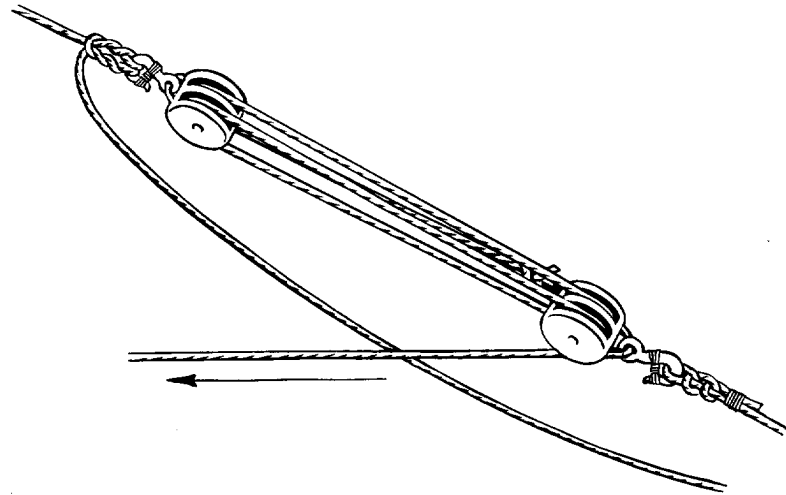

Details of luffing tackle.

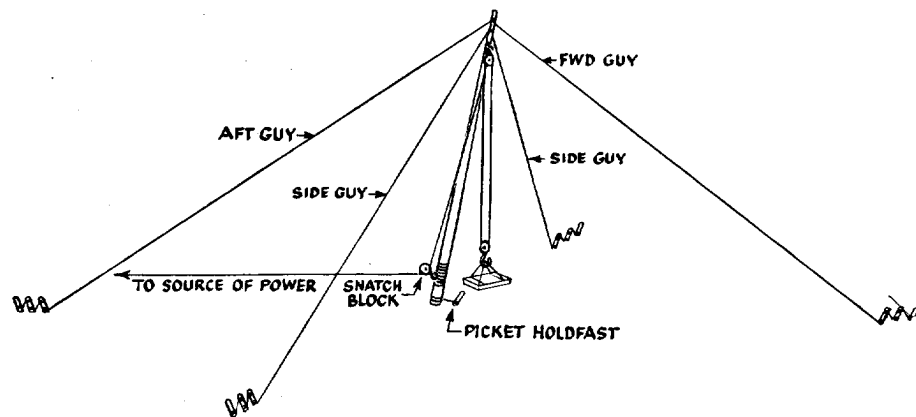

FIGURE 7.—*Gin pole.*

A. DESCRIPTION

1. A gin pole is a single pole held in nearly upright position by four guy lines, used for supporting a tackle to lift or lower weights.
2. It is constructed from a single pole or square timber that has been tapered or chamfered at the top. The shorter the length of pole that bears the load, the greater the load the pole can carry.

MAIN TOPICS

TEACHING POINTS

3. A block and tackle is lashed to the top of the pole. The hauling part of the tackle leads through a snatch block at the base of the pole to the source of power.
4. Square lashing for top of gin pole.
 - a. Ledger to pole.
5. Round lashing for base of gin pole.
 - a. Snatch block to pole.

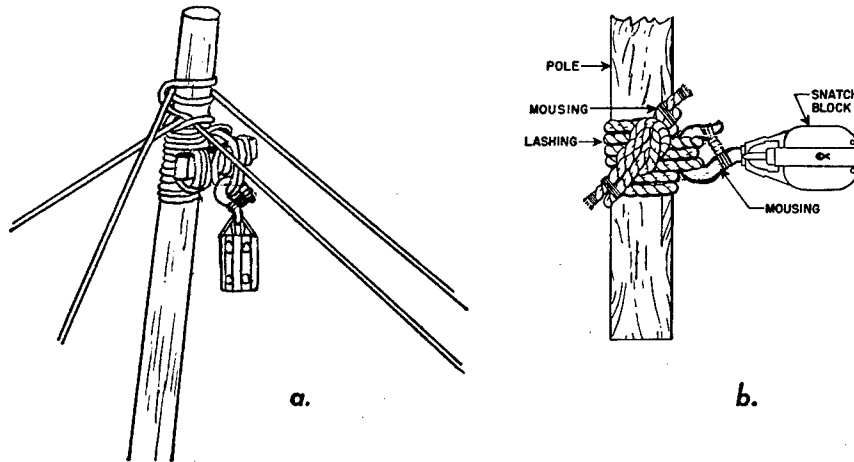

FIGURE 8.—Lashings.

a. Square lashing. b. Base lashing.

6. Pickets or holdfasts.

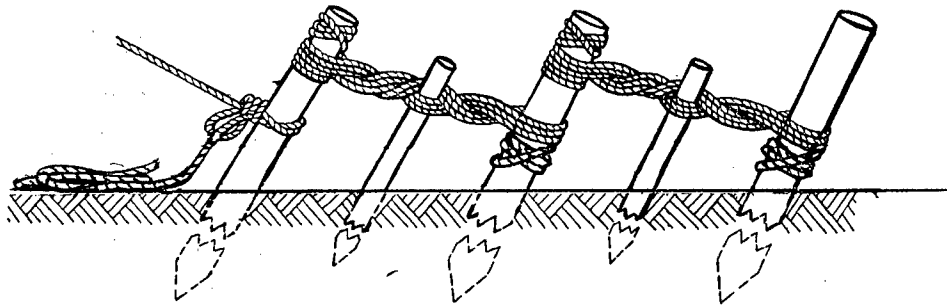

FIGURE 9.—Pickets

MAIN TOPICS	TEACHING POINTS
A. DESCRIPTION—CON.	<ul style="list-style-type: none"> a. A single picket in undisturbed loamy soil will hold up to 700 pounds. b. A 1-1-1 combination (figure 9) will hold 1,800 pounds.
B. CONSTRUCTION AND ERECTION	<ul style="list-style-type: none"> 1. Steps: <ul style="list-style-type: none"> a. Lash top of gin pole. b. Secure and mouse tackle block. c. Lash snatch block to base. d. Tie guy lines to top of gin (clove hitch in middle of rope). e. Prepare base hole (use plate in soft area). f. Prepare pickets (distance of pickets from base of gin should not exceed twice the length of the pole). 2. Review TM-14-1, chapter 3. 3. Erecting: <ul style="list-style-type: none"> a. Guiding base into hole. b. Raising. c. Securing to pickets. d. Applying luffing tackle.
C. OPERATION	<ul style="list-style-type: none"> 1. Attaching to object to be lifted. 2. Position of men. <ul style="list-style-type: none"> a. Human power—equal manpower on each side of rope pull. b. Position of leader. 3. Use of luffing tackle. <ul style="list-style-type: none"> a. Luffing distance over from vertical not to exceed $\frac{1}{4}$ of pole height before application of load, and $\frac{1}{2}$ of pole height after application of load.

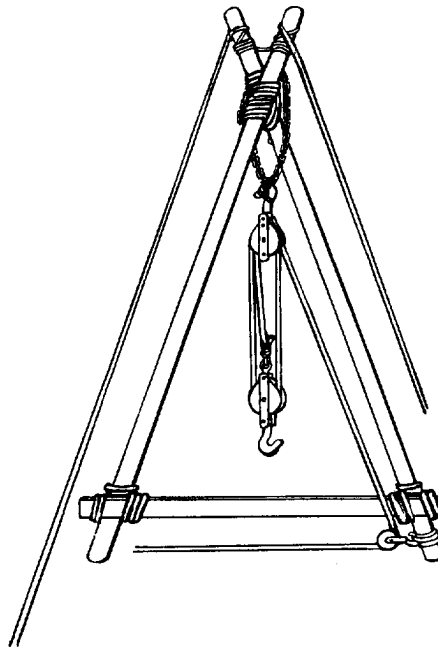

FIGURE 10.—Sheerlegs.

MAIN TOPICS

TEACHING POINTS

SHEERLEGS (A-FRAME)

A. DESCRIPTION

B. CONSTRUCTION AND ERECTION

1. Guiding rules:
 - a. Width at base should be $\frac{1}{3}$ to $\frac{2}{3}$ of height.
 - b. Guy line pickets should be the distance from the base times twice the height.
 - c. Maximum distance of luff should be $\frac{1}{3}$ of the height before application of load and $\frac{1}{2}$ of height after application of load.

1. Two poles lashed together at top, with feet apart to form an inverted "V". The poles are held upright by guys and are used in a variety of ways for lifting or lowering a load. Its construction makes possible vertical or horizontal movement. Horizontal movement of load is obtained by drifting.
2. Hoisting tackle is suspended from the lashed intersection of the frame.
3. Two guys secured to top of frame and properly anchored provide a forward angle.

1. Steps:
 - a. Place poles or square timber of equal length side by side (be sure butts are even).
 - b. Insert spreader block (2 inch) between 2 timbers or poles.
 - c. If timbers are used, chamfer edges where lashing is to be applied.
 - d. Follow steps A and B in figure: clove hitch, round lashing, frapping, and second clove hitch. Remove spreader blocks.

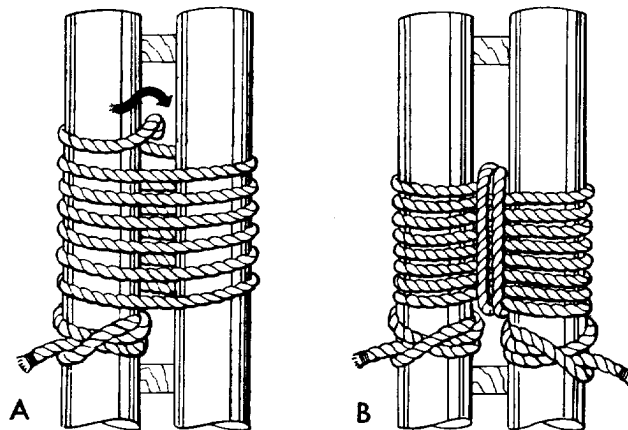

FIGURE 11.—Sheerlegs lashing.

- e. Turn on edge and spread legs apart to the desired angle.
- f. Prepare sling and hand tackle.
- g. Attach the fore and aft guy lines.
- h. Prepare pickets.
- i. Prepare base holes.
2. Erecting (raising and placing):
 - a. Raise by having 2 men guide timbers into holes, one man lifting at apex and other pulling on guy line.
 - b. Secure legs to prevent spreading.

MAIN TOPICS	TEACHING POINTS
-------------	-----------------

C. OPERATION

1. Position leader.
2. Position manpower.
3. Attach object to be lifted.
4. Use luffing tackle.
5. Raising and luffing.

TRIPOD

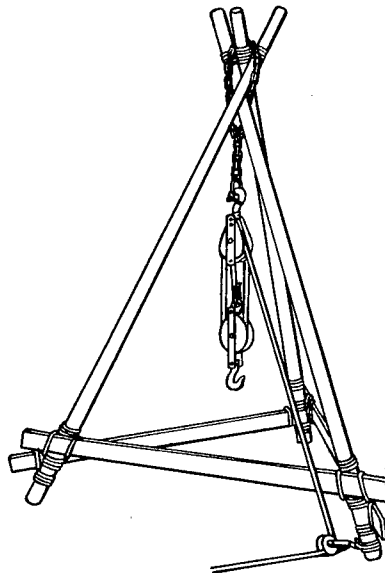

FIGURE 12.—Tripod.

A. DESCRIPTION

1. Consists of three poles lashed together at top, so, when erected, they form an equilateral triangle over the load to be lifted.
2. A tripod is designed to lift a heavy load vertically where there are no other structures immediately above the load to which blocks may be safely secured.
3. The figure-eight lashing is used to secure the top of the tripod.

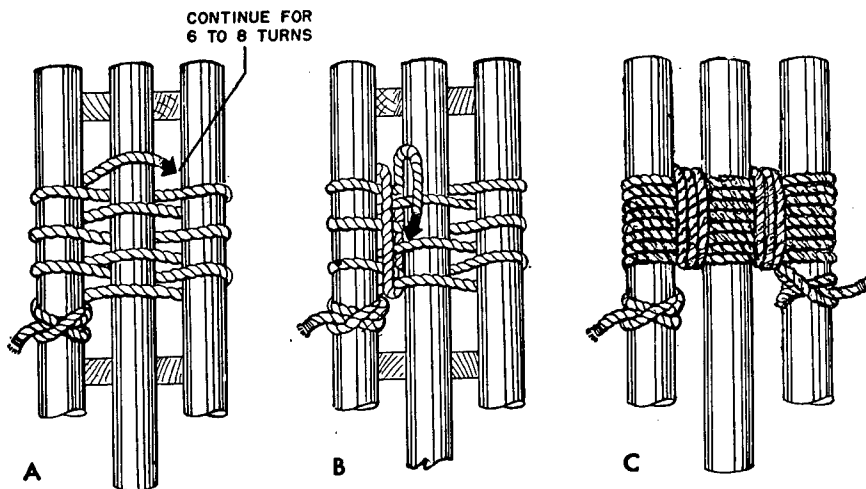

FIGURE 13.—Lashing for tripod.

MAIN TOPICS	TEACHING POINTS
A. DESCRIPTION—Con.	4. In securing a block and tackle to the top and the hauling part of the tackle, a rope, chain, or wire sling, leads through a snatch block at the base of one of the poles forming the tripod.
B. CONSTRUCTION, ERECTION, AND OPERATION	<p>1. Steps in lashing:</p> <ol style="list-style-type: none"> Lay 3 poles or timbers across 2 sawhorses, parallel, with butts even. Chamfer edges where lashing is to be applied. Spread and insert spacers (2-inch pieces). Start with a clove hitch on timber A or C. Complete figure-eight lashing ($\frac{1}{2}$-inch rope) for about 6 inches. Make 3 or 4 frappings between timbers. Finish off with a clove hitch on outer timber. Remove spacers. <div data-bbox="406 787 1258 955" style="text-align: center;"> </div> <p style="text-align: center;">FIGURE 14.—Preparing poles.</p> <p>2. Raising and placing.</p> <ol style="list-style-type: none"> Remove saw horses. Raise butt of timber B high enough to cross timbers A and C, thus forming a "V" in which the top of B will rest. Spread timbers A and C to desired distance. Dig 6-inch holes for these butts to provide firm footing. If ground is soft, a square platform should be placed at bottom of hole. Guide butts of A and C into holes as butt B is pulled back. This causes the top to raise. Continue until top is about 5 feet high.

MAIN TOPICS

TEACHING POINTS

JIB ARM
ERECTION, AND
OPERATION—Con.

- f. Place sling over top and put standing block into the sling and then mouse the hook.
- g. Continue to raise the tripod to its desired height; butts of tripod should be equal distance apart. The spread should not exceed half the distance from top of sling to ground.
- h. Dig the hole for butt B and ease it into the hole.
- i. Secure tripod legs together by:
 - (1) Lashing rope, or
 - (2) Lashing 2" x 4" pieces (ledger).

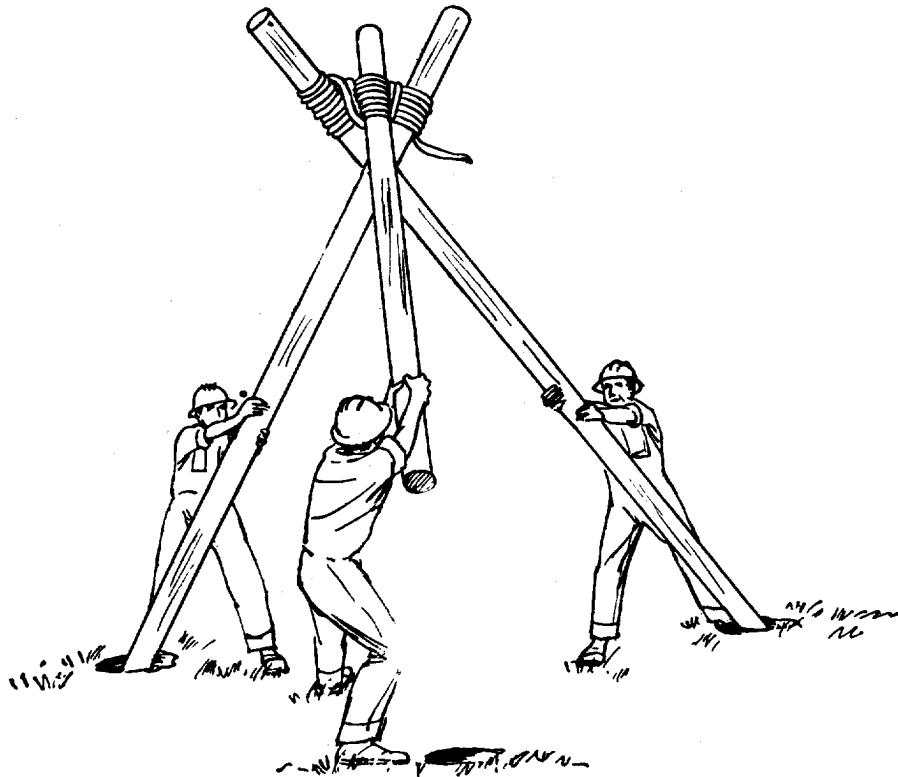

FIGURE 15.—Raising and placing tripod.

- j. Secure snatch block to desired leg (direction of pull will determine proper leg to use).
- k. Place hauling line in sheave and close snatch block.
- l. Secure hook of running block to object to be lifted.
- m. Men on hauling line raise object.
- n. Use blocking or cribbing materials.

MAIN TOPICS

TEACHING POINTS

JIB ARM

A. DESCRIPTION

1. A jib is a strong pole or timber with one end anchored down and the other projected over or from a support to allow hoisting or lowering by means of a tackle. If tapered, the large (butt) end should be the protruding (block support) end. A jib is frequently used in rescue operations involving a stretcher casualty who must be kept horizontal while being lowered.
2. Jib must be supported.

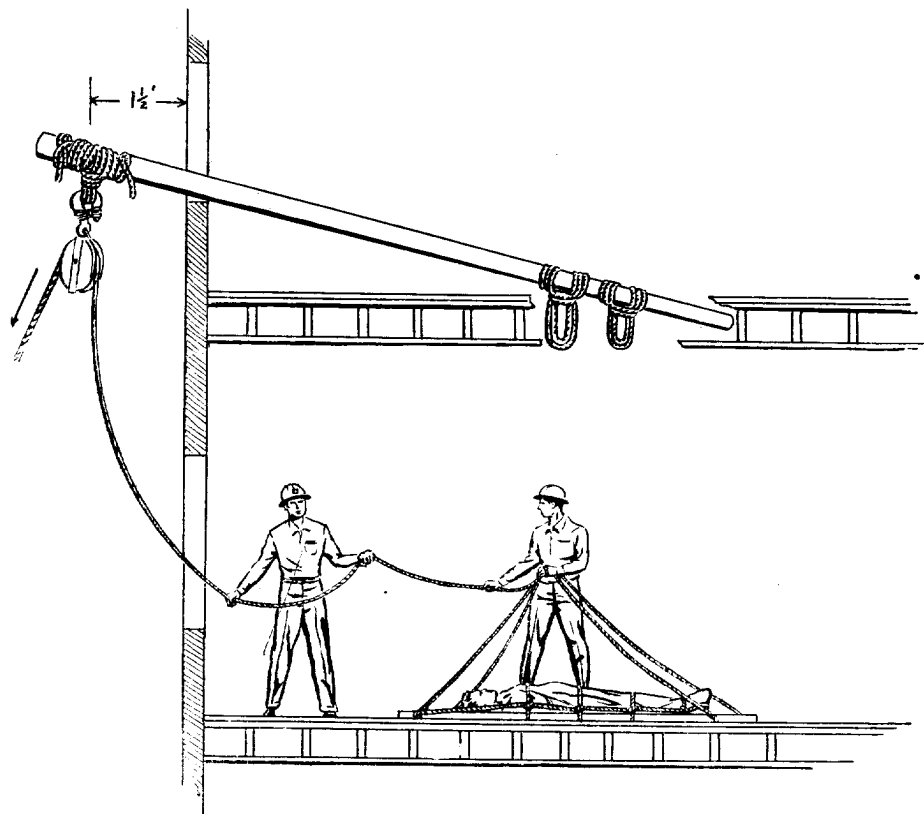

FIGURE 16.—Jib arm

B. CONSTRUCTION AND ERECTION

1. Select timber or pole not smaller than 4 inches in diameter. Its length will depend on how far over the ledge or sill the butt end is to protrude and the location of anchorage for tail end.
2. Secure block with a tight lashing, with as many turns through the hook as there are sheaves in standing block.
3. Mouse the hook.
4. Anchor tail end down by lashing to something substantial, such as roof or floor joists. The jib should never be allowed to rock.
5. Pull hook of movable block straight down into the window or opening in wall where the load is to be attached.
6. Secure the weight (horizontal stretcher) to the running block. Mouse the hook.

MAIN TOPICS	TEACHING POINTS
<p>B. CONSTRUCTION AND ERECTION—CON.</p>	<p>7. A rescuer inside the room from which stretcher is lowered snubs haul line securely. He pays out haul rope to lower load.</p> <p>8. Rope must always be protected against chafing where it crosses an object.</p> <p>9. Use of slings.</p> <p>Slings are necessary parts of rigging where heavy objects must be hoisted and moved around. A sling may be constructed from rope or wire formed into a continuous loop and called an endless sling. An eye sling is a piece of rope or wire with an eye spliced on each end.</p> <p>When using slings around weights with sharp edges, pad the edges to prevent excessive cutting and reduce the angle of the pull. A greater load can be lifted when the legs of a sling are perpendicular to the plane of the load. The more acute the angle between the legs of the sling and the plane of the load, or the horizontal, the greater the tension on the single legs of the sling when the force is applied. The diagram below shows how the efficiency of the sling decreases as the acuteness of the angle increases.</p>

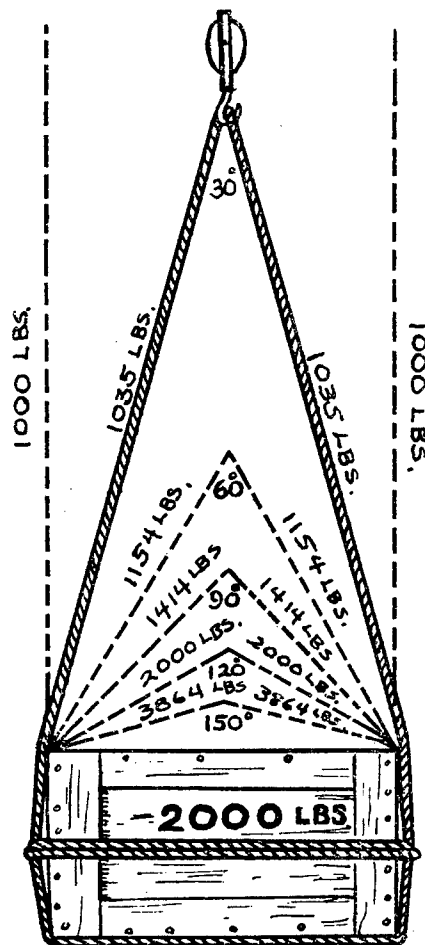

FIGURE 17.—Slings.

STUDENT PARTICIPATION:

Trainees, as members of a team, actually construct, assemble, and operate the four types of riggings under supervision of the instructor.

HANDOUT MATERIALS AVAILABLE:

Instructor should contact rope manufacturers for pamphlets.

LESSON AIDS

6—Care and Use of Masks

Masks are used by rescuers when detection devices or common sense indicates that something other than normal air is present. Although often referred to as "gas masks" they also protect against fumes, mists, and dust.

Filter-type masks do not supply oxygen and can be used only in air containing sufficient oxygen to sustain life. Air deficient in oxygen may be encountered in covered tanks, manholes, vaults, and other confined unventilated spaces, such as overcrowded shelters which may have become sealed. The symptoms of oxygen deficiency may be slight, accompanied by a sense of suffocation or vague distress. If a rescuer experiences any unusual symptoms he should return to fresh air as soon as possible. Concentrations of noxious gases too high for extended use of this type of mask can usually be detected by smell or taste or an irritation of the mucous membrane.

The self-contained, self-generating oxygen-breathing apparatus is used in areas deficient in oxygen, or containing irrespirable vapors or gases. These masks may be used in any oxygen deficient air, or where dusts, gases, fumes, or mists are present. The mask operates independently of the outside air. It uses a canister containing a chemical which, upon contact with the moisture in the exhaled breath, generates oxygen for breathing, and absorbs exhaled carbon dioxide. Exhaled air blows from the facepiece through the wearer's right hand breathing tube, thence through the plunger casting and down the center tube of the canisters, to the bottom. It then spreads and passes up through the chemicals, the moisture liberating oxygen and any carbon dioxide present. The liberated oxygen flows from the top of the canister through the internal tube to the bottom of the wearer's right side of the breathing bag; then through the bag to the left side, and into the facepiece through the left side breathing tube. The bag serves as a flexible external lung and as a reservoir for storing respirable air for breathing. The surface of the bag acts as a cooling medium and reduces the temperature of the exhaled air in the bag so it is comfortable for breathing.

The self-contained, demand-type mask is used by many fire departments. It is simple and inexpensive to operate. In comparing this mask with the self-generating oxygen-type, the advantages and disadvantages should be discussed.

The instructor should stress the importance of a thorough understanding of:

1. Mask limitations.
2. Principle of operation.
3. Maintenance and care.

LESSON PLAN NO. 6

COURSE: Heavy Duty Rescue—Course No. 14.3
LESSON TITLE: Care and Use of Masks

TIME: 2 Hours

TRAINING MATERIALS:

Four filter-type masks per class.

Two self-contained, self-generating on demand type masks per class.

One ½-inch 50-foot rope per 3 trainees.

One gas or smoke chamber.

Smoke pots or smoke bombs.

REFERENCES:

Rescue Techniques and Operations, FCDA, TM-14-1, chapter 2.

Manufacturer's instructions on mask case.

MOTIVATION:

Rescue workers should be trained in the proper use of masks for their own protection. Not only must they know how to operate masks, but they must know the limitations of each kind.

MAIN TOPICS	TEACHING POINTS
A. WHEN TO USE MASK	When gas is known or suspected to be present in the rescue area.
B. FILTER MASK	<ol style="list-style-type: none"> 1. Instructor should display the mask. <ol style="list-style-type: none"> a. Point out various parts of the mask and how they operate. b. Discuss its limitations. c. Explain the steps in putting on and adjusting the mask. d. Demonstrate steps. e. Demonstrate removal of the mask. 2. Review TM-14-1, chapter 2. 3. Read step-by-step procedure inside cover of mask case. 4. Trainees should practice putting on and taking off mask. 5. Instructor should watch trainees and make corrections. 6. Instructor should read instructions for proper care and cleaning. 7. Instructor should insist that masks be cleaned before they are put away.
C. SELF-CONTAINED MASK	<ol style="list-style-type: none"> 1. Self-generating type. <ol style="list-style-type: none"> a. Instructor should display the mask. b. Read instructions on the case cover. c. Name parts of the mask. d. Discuss merits and limitations. e. Demonstrate step-by-step procedure in donning the mask. f. Discuss cleaning. g. Have trainees don the mask following the proper procedure. 2. Instructor should refer to TM-14-1, figure 31, chapter 2. 3. Demand type. <ol style="list-style-type: none"> a. Instructor should follow same steps as for self-generating mask.
D. LIFELINE	<ol style="list-style-type: none"> 1. The lifeline is a means of communication for rescuers who must enter hazardous enclosures or toxic atmosphere. It enables them to keep in contact with persons outside by sending and receiving rope signals. 2. Proper securing of line to rescuer wearing mask. 3. Standard signals: <ol style="list-style-type: none"> a. <i>1 pull</i>—Stop (if moving); O. K. (if at rest). b. <i>2 pulls</i>—Advance. c. <i>3 pulls</i>—Come out at once. d. <i>4 pulls</i>—Distress, need help. 4. A lifeline should not be used to pull a collapsed worker out of danger. Its function is to lead rescuers to him.
E. PRACTICAL WORK	<ol style="list-style-type: none"> 1. Instructor should organize squads for entrance to a gas chamber. (Smoke or tear gas may be generated for this purpose.) 2. Remain in chamber long enough to convince the trainee of performance of the mask. 3. Invite trainees to enter the chamber for only a few seconds without mask.

STUDENT PARTICIPATION:

Unless trainees have ailments which might be aggravated, they should be required to go through these drills. They can gain confidence in their masks only by understanding them thoroughly.

HANDOUT MATERIALS AVAILABLE:

Instructor should contact mask manufacturers for pamphlets.

LESSON AIDS

7—Breaching

8—Shoring (Part II)

Walls separating rescuers from trapped persons may have to be breached if there is no way around, over, or under them. For example, the wall of a shelter whose exits have been blocked. Breaching is hard work and requires great care and skill. It should never be rushed.

When buildings collapse, various sections often tend to hold together to form voids. The sections raised to facilitate the entrance of rescue men into voids must be supported or braced to insure safety of the workers.

Walls that may be in danger of collapsing or roofs of shelters weighted with debris may also have to be shored or braced to prevent their collapse on rescue workers. Shoring and bracing, as defined in rescue work, is a method of erecting a series of timbers to stabilize a wall or prevent further collapse while rescue operations are being carried on.

Shoring and bracing by rescue squads must be considered temporary, and too much time should not be spent in elaborate shoring.

All timber materials used in shoring and bracing operations should be salvaged from the debris if possible. Timbers may be hauled to the scene of operation from lumber yards or stockpiles.

LESSON PLAN NO. 7

COURSE: Heavy Duty Rescue—Course No. 14.3

LESSON TITLE: Breaching Walls

TIME: 1 hour

TRAINING MATERIALS:

- Blackboard, chalk, eraser.
- Chisels: 8-, 12-, and 18-inch.
- Mason's hammer (4-pound).
- Brick wall.
- Goggles and gloves.

REFERENCE:

Rescue Techniques and Operations, FCDA, TM-14-1, chapter 3.

MOTIVATION:

To gain entry into a building through a basement or wall to rescue a casualty, it may be necessary to breach a wall. Breaching is hard work, but much effort can be saved by a planned approach. Rescuers should know something of materials used in walls.

MAIN TOPICS	TEACHING POINTS
A. TYPES OF WALLS	<ol style="list-style-type: none">1. Brick with lime mortar. Walls built with lime mortar are usually easy to demolish or pierce, especially if they are old. As a rule, the bricks can be withdrawn whole without difficulty. It is usually necessary to put in some form of headpiece to prevent the bricks immediately over the hole from falling in. As an alternative, the hole may be made in an inverted V-shape.2. Brick with cement mortar. Cement mortar is usually as strong as the brick itself. In general, holes large enough for rescue purposes can be safely made in these walls. Walls built with cement mortar usually break into chunks, with fractures through the bricks as well as the joints, whereas in lime-jointed brickwork the bricks usually remain whole.3. Stone. Walls of stone may be of different types, with stone of various sizes held together by a variety of different bonding agents. Support is needed at the roof only when a hole is cut through a wall of fairly small loose stones. Stone basement walls are usually thick and difficult to cut.4. Concrete. It is almost impossible to cut through concrete rapidly unless a power impact tool is used. Power tools should be called for without delay whenever such work is necessary. Care must be taken that vibration of the power tool does not loosen upper sections of the wall or debris.

MAIN TOPICS	TEACHING POINTS
B. METHOD	<ol style="list-style-type: none">1. Except in the case of concrete, the procedure in breaking a wall should be to cut a fairly small hole first and then enlarge it to the required size. With concrete walls, it is better, unless they are very thick, to make a cut around the edge of the piece to be removed. If the walls are reinforced, the cut must be deep enough to reach the reinforced bars so these can be cut with a hacksaw or by an oxyacetylene torch.2. If the oxyacetylene torch is used, care must be exercised that combustible debris is not ignited, nor utility gas present, and that ventilation is provided. Emergency fire-fighting equipment should always be kept on hand when using an oxyacetylene torch.3. Unless there are other considerations, walls should be broken through at the thinnest part.4. When cutting into walls or floors of large buildings, care must be taken to avoid weakening the main beams and columns supporting the building.

STUDENT PARTICIPATION:

Trainees should breach a wall, directed and assisted by the instructor. If combination concrete block and brick wall is available, it should be used as it provides experience in breaching through two kinds of material.

HANDOUT MATERIALS AVAILABLE:

None.

LESSON PLAN NO. 8

COURSE: Heavy Duty Rescue—Course No. 14.3
LESSON TITLE: Shoring (Part II)

TIME: 2 hours

TRAINING MATERIALS:

Flying Shore: Horizontal beam.
Wallplates.
Lumber for straining pieces and cleats.
Timber for rakers.
Wood wedges.
Clawhammers.
Pry bars.
Handsaw or power saw.
Nails.
Chalk.
Miniature model (optional).

REFERENCE:

Rescue Techniques and Operations, FCDA, TM-14-1.

MOTIVATION:

Further collapse is often probable in collapsed and damaged buildings. To protect rescue workers and trapped casualties, precautions must be taken to prevent further collapse. This may require stabilizing damaged walls, ceilings, or other parts of the structure. In most instances, temporary supports can be erected quickly if the rescue team knows how to do it.

MAIN TOPICS	TEACHING POINTS
A. DEFINITION	<ol style="list-style-type: none">1. Shoring, as used in rescue operations, is a series of timbers erected to stabilize or brace a wall or to prevent further collapse of a building while rescue operations are being carried on.<ol style="list-style-type: none">a. To protect lives of rescue workers or casualties.b. Temporary in nature, only sufficient to meet immediate urgent demands.2. Main types:<ol style="list-style-type: none">a. Raking shore (review Lesson Plan No. 5, Course No. 14.2 Light Duty Rescue Course).b. Flying shore.c. Vertical shore (review Lesson Plan No. 5, Course No. 14.2 Light Duty Rescue Course).
B. PRECAUTIONS	<ol style="list-style-type: none">1. Do not attempt to restore walls to original position with shores.2. Forcing portions of structures may cause further collapse.3. Secure shores firmly, but gently and gradually, without shock to the structure, using pry bars and wedges or jacks, rather than hammering wedges into position.

MAIN TOPICS

TEACHING POINTS

C. FLYING SHORE CONSTRUCTION

1. Used to brace wall when a sound wall is near enough to serve as a footing.
2. On a blackboard the instructor should sketch a flying shore and name the parts:
 - a. Horizontal beam.
 - b. Wallplates.
 - c. Struts.
 - d. Straining pieces.
 - e. Cleats and wedges.
3. See TM-14-1, chapter 3.
4. Not advisable if walls are more than 25 feet apart.
5. Spaced at 8- to 12-foot intervals along a wall.
6. Steps in erection:

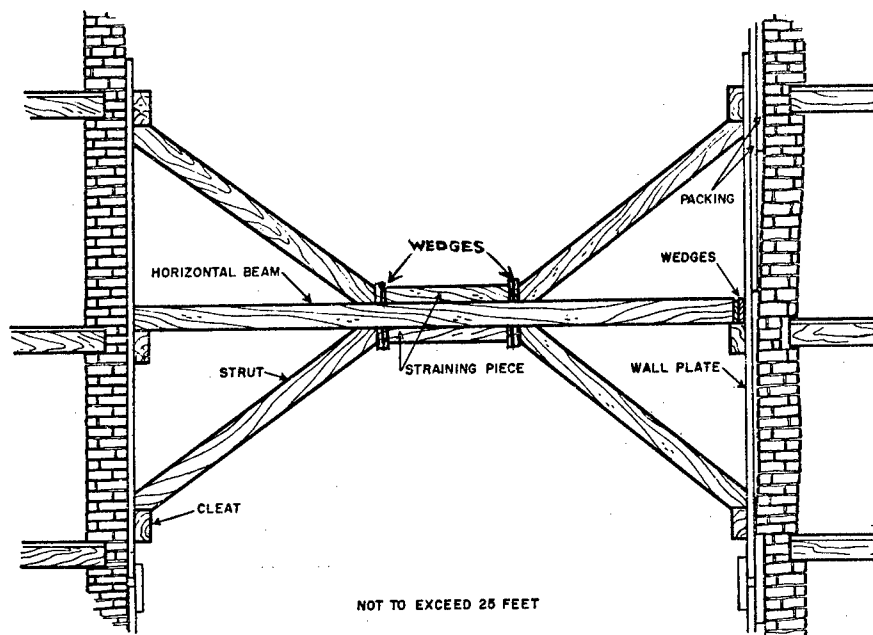

FIGURE 18.—Flying shore.

- a. "Lay off" the job on the ground before erection, then attention can be given to measurements and angles.
- b. Set struts at an angle not greater than 45° to the horizontal.
- c. Nail cleats for supporting horizontal beam and struts to wallplate.
- d. Nail straining pieces to horizontal beam. Length is governed by height of floors and length of beam. (Beam may be laminated.)
- e. Place wallplate in position.
- f. Place horizontal beam in position and tighten by wedges and shims.
- g. Place struts into position and tighten with wedges.

STUDENT PARTICIPATION:

Instructor should use the blackboard in discussing shoring. He should divide class into three teams, giving a problem in shoring to each team. When shores are completed the instructor should examine them and offer comments. If time permits, each group should complete a second shore.

HANDOUT MATERIALS AVAILABLE:

None.

LESSON AIDS

9—Trenching, Tunneling, and Shafting

As an introduction to this lesson the instructor should explain the increasing importance of shelter as a basic civil defense concept. With the development of weapons such as the intercontinental ballistic missile (ICBM) there may not be sufficient warning time for evacuation of a city. People will have to take shelter in the target area, and they may have to be rescued from these shelters.

Trenching, tunneling, and shafting are techniques for reaching a specific spot, either a place where someone is known to be trapped, or a void in the debris from which further exploration of likely places can be made. They are the most hazardous of all rescue techniques if not conducted properly. One of these methods should be decided upon only after all other rescue methods have failed or been determined impractical.

In trenching, tunneling, and shafting into debris unnecessary disturbance or movement of rubble, which could cause a cave-in and possible injury to the rescuer, should be avoided.

The passageway should be large enough to permit extrication of the casualty. Too much room is better than too little.

Material for timbering can usually be found at the rescue scene. However, rescuers should not overlook nearby lumber yards or stockpiled lumber. The size of the timbers will be governed by the nature of the job and material available, but they should be large enough for safety.

Debris may contain obstacles such as heavy timbers, steel members, masses of masonry, or brick work which must be avoided, removed, or cut. When rescuers use oxyacetylene to cut a metal obstruction they should be careful not to set the debris on fire or allow the air in the tunnel to become foul.

Other obstacles impeding progress are:

1. Heavy blocks of masonry. These may be easier to go around than through.
2. Gas pipes, water pipes, and electric cables. Avoid cutting these if possible; call for a utility service representative to cut off the service.
3. Tangled electric lighting wire.

Precautionary practices include:

1. If dust is troublesome, use water spray.
2. Wear helmet and dust goggles.
3. Never work without gloves.
4. Avoid using sharp tools on rubble near a trapped person.
5. Avoid exhaustion from overwork.

DEBRIS TUNNELING CONSTRUCTION OF TUNNEL

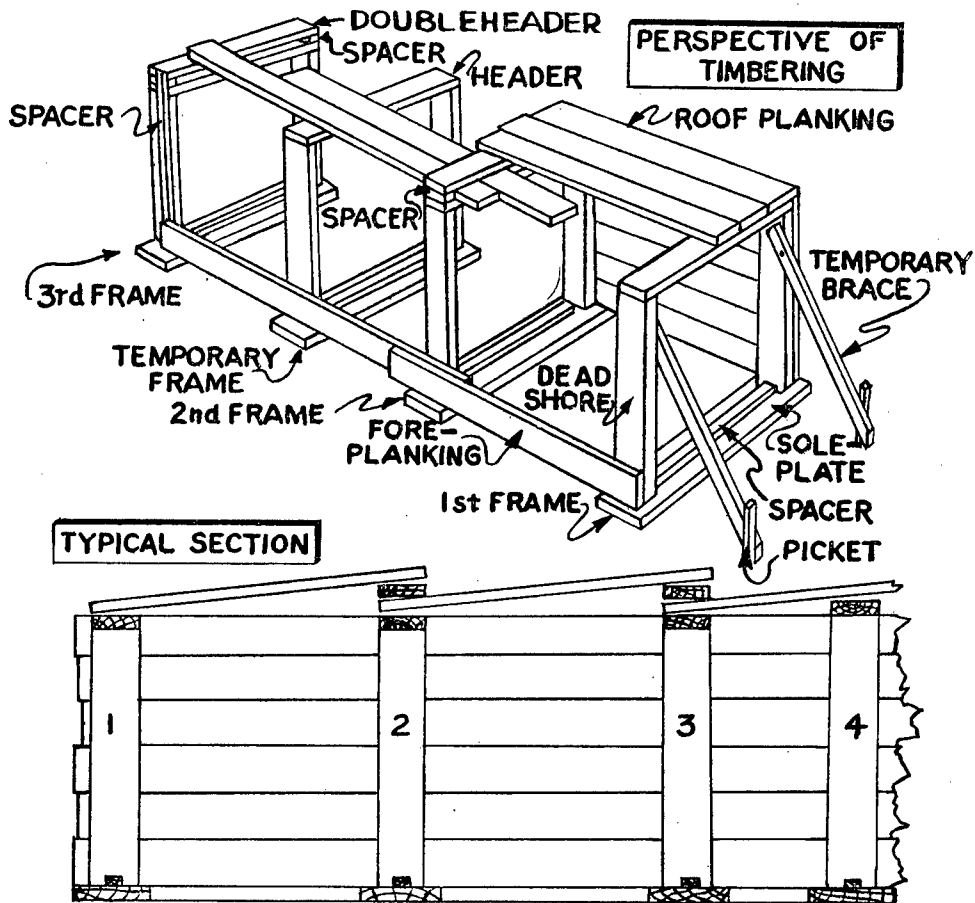

NOTE 1-2-3 PERMANENT FRAMES
4 TEMPORARY FRAME

FIGURE 19.—Tunnel construction.

LESSON PLAN NO. 9

COURSE: Heavy Duty Rescue—Course No. 14.3

LESSON TITLE: Trenching, Tunneling, and Shafting

TIME: 4 hours

TRAINING MATERIALS:

Film projector and screen.

Film "Trapped."

Film "Debris Tunneling" (British Information Service, New York City), if available.

Blackboard, chalk, eraser.

Rescue truck tools.

Materials found in debris.

REFERENCE:

Rescue Techniques and Operations, FCDA, TM-14-1.

MOTIVATION:

Trenching, tunneling, or shafting is done only after all other methods of reaching trapped persons have failed. Each method is dangerous and fatiguing. Frequent relief is necessary and relief personnel must be so well trained that they can recognize readily the stage of progress, thus eliminating extensive explanation.

MAIN TOPICS	TEACHING POINTS
TRENCHING A. How	<p>Trenching may be done to remove trapped persons when the surrounding debris is not too high and the distance to them not long. No "rule of thumb" for the maximum height of rubble that would safely permit trenching can be given because the pressure on the side of the trench depends on many conditions, such as slope and composition of rubble. If the debris is over 8 feet high, trenching would probably not be practical or safe because of the danger of cave-in. Then, tunneling would be done.</p> <ol style="list-style-type: none">1. Trenching may be started by picking out the largest pieces of timber or stone or other objects from the face of the pile nearest the objective. Then, by hand methods, a trench is worked into the debris with a minimum of material removed. The sides of all trenches should be secured by adequate sheathing and bracing.2. Trenching jacks or braces (whalers) may be used successfully to support the sides of trenches.3. If trenches are 4 feet or more in depth, wood sheet piling should be at least 2 inches thick. When over 7 feet deep, piling thickness should be increased.4. Trenching into debris should always be used to reach a specific point but, because obstructions cannot always be located until they are actually encountered, a leader may decide to start two or more trenches to a given point at the same time.

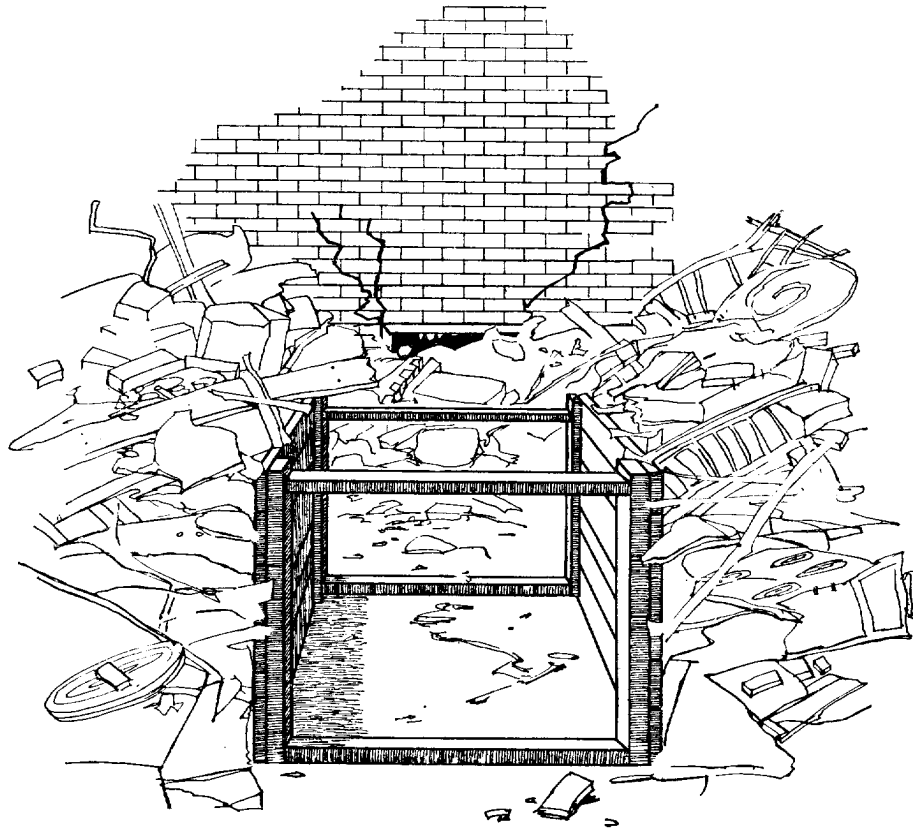
FIGURE 20.—*Trenching.***B. PRECAUTIONS**

1. Trenching is dangerous. If a trench collapses, a worker has little chance of avoiding injury.
2. Unnecessary movement of the debris pile should be avoided and people should not be allowed to crawl over rubble near any trenching operation.
3. Rubble taken from a trench should be deposited far enough from the entrance to avoid rehandling. It should be sorted and similar materials piled together and marked for later use.
4. Men working in rubble should always wear helmet and protective gloves.
5. Relief should be provided for rescuers to avoid overstrain and fatigue.

TUNNELING**A. LEADERSHIP AND TRAINING**

1. Tunneling should be done only after reconnaissance has established a definite "fix" on a casualty and no other method of access is feasible.
2. Tunneling is usually done through debris, not through earth, pavement, or concrete. It is a means of reaching underground shelters, subways, and passenger vehicles covered with debris.
1. Efficient tunneling requires:
 - a. Exact location of trapped person.
 - b. Careful selection of starting point.
 - c. Employment of uniform and safe methods.
 - d. Maximum utilization of voids—the path of least resistance.
 - e. Proper deployment of rescue manpower. Preferred are men of small build, tough and wiry, rather than big and strong.

MAIN TOPICS	TEACHING POINTS
B. ORGANIZATION	<ol style="list-style-type: none"> 1. The leader of the tunneling crew should: <ol style="list-style-type: none"> a. Organize his unit so each member has a specific job. Because much of this work is exhausting, and no one should work too long, he should name alternates for each job. b. Select the starting point which depends on several factors: <ol style="list-style-type: none"> (1) Length of tunnel required. (2) Type of debris. c. Select a location for the rubble store pile. d. Organize the crew into work groups: <ol style="list-style-type: none"> (1) Men to gather timbers. (2) Men to lay out tools. (3) Men to start the tunnel. e. See that all men are properly equipped. <ol style="list-style-type: none"> (1) Personal equipment: heavy gloves, helmets, and electric cap-lamp. (2) Organizational equipment: axe, saw, pipe cutter, sledges and hammers, chisels, miner's pick, debris basket, shovel, stirrup pump, lifeline, and self-energizing telephone set.
C. CONSTRUCTION	<ol style="list-style-type: none"> 1. Starting point. <ol style="list-style-type: none"> a. The starting point for the tunnel should be as close to an access location as possible, with adequate space for piling up removed debris and rubble. Wood, brick, and other materials should be separated for later use in the tunneling operations. b. Manpower should be used efficiently and divided into: <ol style="list-style-type: none"> (1) Tunneling group. (2) Framing group. c. To equalize the workload, the leader should alternate personnel within the 2 groups. 2. "Facing off." <ol style="list-style-type: none"> a. While the framing group is preparing frames to assemble in position as the work progresses, the tunneling group should "face off" the pile so that, as the tunnel is started, it will pierce the face of the pile. 3. Framing. <ol style="list-style-type: none"> a. The framing group should prepare: <ol style="list-style-type: none"> (1) 1 single header frame for the portal. (2) 1 temporary frame for use inside the tunnel as work progresses. (3) As many doubleheader frames as are required to complete the operation. 4. Description of the above frames: <ol style="list-style-type: none"> a. The portal frame is constructed as shown in figure 21. Inside dimensions are 3' x 3' minimum.

C. Construction—
Continued

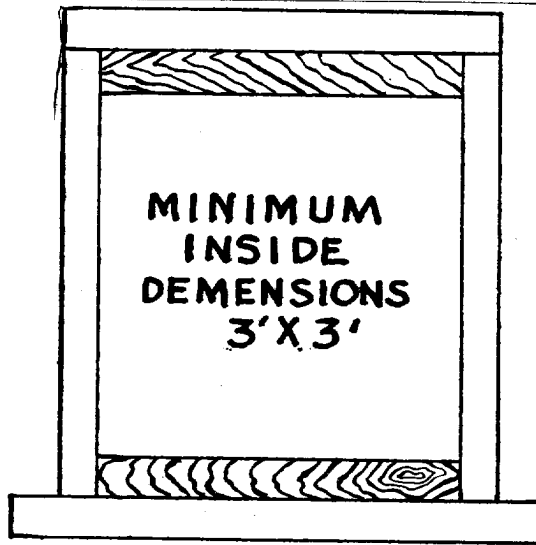

FIGURE 21.—Portal frame.

- b. The temporary frame is constructed like the portal frame, with an increase of two inches to width and height. This permits forepoling on roof and foreplanking on sides.

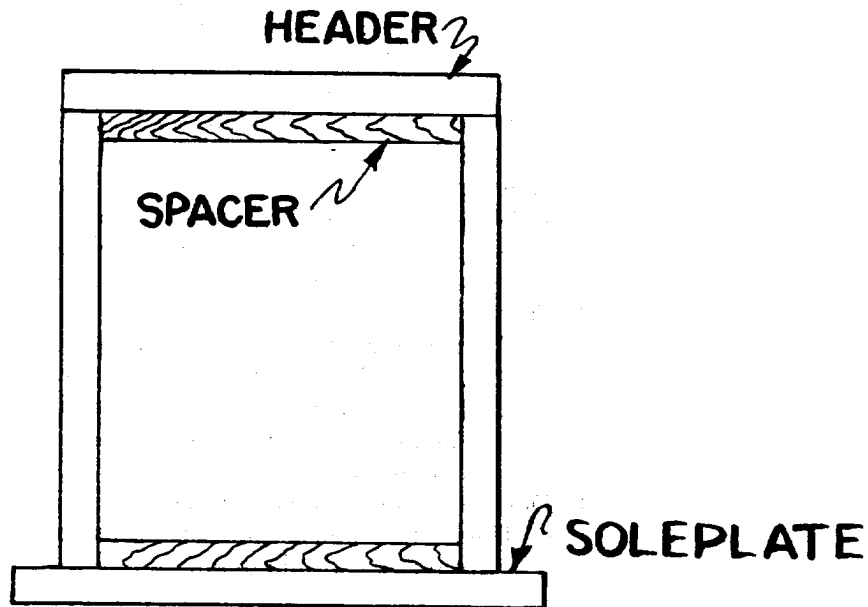

FIGURE 22.—Temporary frame.

- c. Doubleheader frames (permanent). These are identical frames for the continuation of the tunneling operation, the quantity depending on the length of the tunnel. Inside dimensions are 3' x 3' minimum.

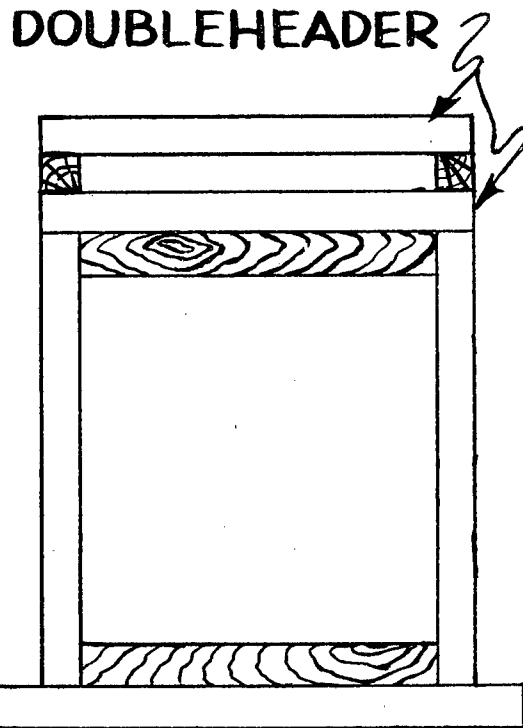

FIGURE 23.—Doubleheader (permanent).

D. TUNNELING (STEPS)

1. Starting.
 - a. Frame (permanent) is set against a cleared vertical face of debris (No. 3 in figure 19).
 - b. Frame (permanent) is set approximately three feet from "faced off" (No. 2 in figure 19).
 - c. Portal frame is set at another 3-foot interval and braced to stakes driven into the ground (No. 1 in figure 19).
 - d. Placing of roof planks. Roof planking is laid across the top of portal frame (No. 1) and first permanent frame (No. 2). Forepoles are then placed through the double crown space to top of next permanent frame (No. 3) and against the "faced off" rubble pile. Rubble is then placed on top of planks to hold them in place.
 - e. Planking on sides of frames. The sides are lined by placing planks long enough to overlap two frames. These side planks are built up from the bottom and held stable against the outside of the frames by piling debris against them.

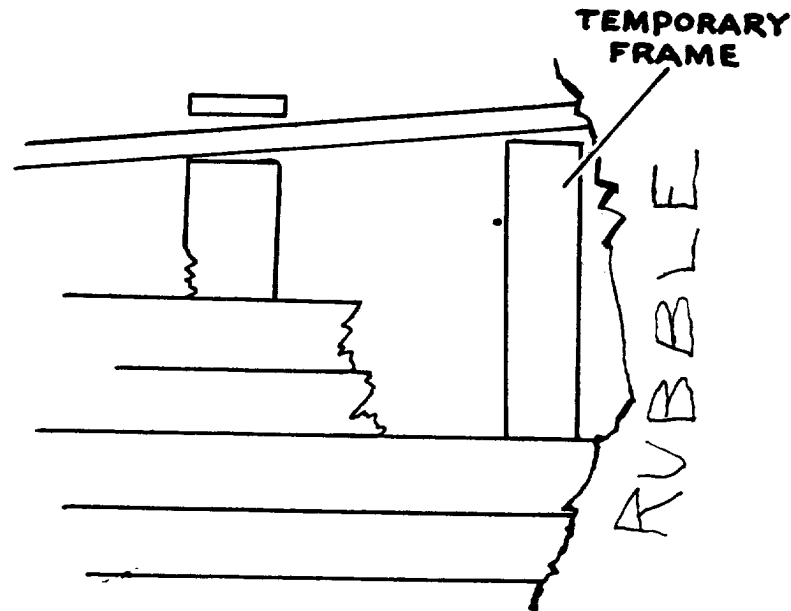

FIGURE 24.—Frame—Side view.

D. TUNNELING
(STEPS)—Continued

2. Tunneling.

- a. After the entrance (first 3 frames), tunneling into the pile begins.
 - (1) One man enters the tunnel with miner's pick and tunneling shovel.
 - (2) A chain of rescuers is set up to relay the debris buckets and frame parts.
 - (3) The "pick and shovel" man removes debris and rubble immediately in front of each plank to be driven (forepoled). As the debris is removed from the lane of a plank, the plank is driven further into the debris. All planks are kept advanced into the debris to avoid cave-in. This method is referred to as forepoling and foreplanking. It is done only on orders from the pick-and-shovel man working on the face of the tunnel.
- b. Temporary frame. When the planking has advanced about 18 inches, the temporary frame is assembled in place. This prevents cave-in between frames No. 3 and the next permanent frame which will be No. 4.
- c. Permanent Frame No. 4. When the planking has advanced another 18 inches beyond the temporary frame, frame No. 4 is assembled in place.
 - (1) In assembling the fourth frame, the following steps should be followed:
 - (a) Set soleplate in place.
 - (b) Set one leg vertically near the end of soleplate. Toenail enough to prevent sliding.
 - (c) Place appropriate end of doubleheader on top.
 - (d) Set another leg into vertical position and toenail and complete positioning of doubleheader.
 - (e) Place and nail spacer to soleplate between uprights.

MAIN TOPICS

TEACHING POINTS

D. TUNNELING (STEPS)—Continued

- (2) Overlapping is relatively easy on the roof planks since the double-header provides a separating collar.
- (3) There is a frictional problem in overlapping the side planks as shown in the plan section view. This can be substantially reduced by:
 - (a) Using the straightest planks available.
 - (b) Removing all nails.

d. Completion of tunnel.

- (1) The continuation of the tunnel to its destination is accomplished by repeating the cycle of operations outlined in the above steps.
- (2) Turns may be made to take advantage of voids or because of subsequent information on the "fix" of the casualty.
- (3) When turns are attempted, the inside dimensions of the tunnel may have to be increased, either horizontally or vertically. Just a few inches make removal of a stretcher-lashed casualty easier.

SHAFTING

1. Purpose of shafting.
 - a. Shafting is used when tunneling is impracticable because of the distance to be worked.
2. A combination of shafting and tunneling is sometimes effective. For example: shafting down to basement level in the ground alongside the building, then tunneling from the bottom of this hole horizontally until the basement is reached, thus avoiding the danger and difficulty of cutting through debris.

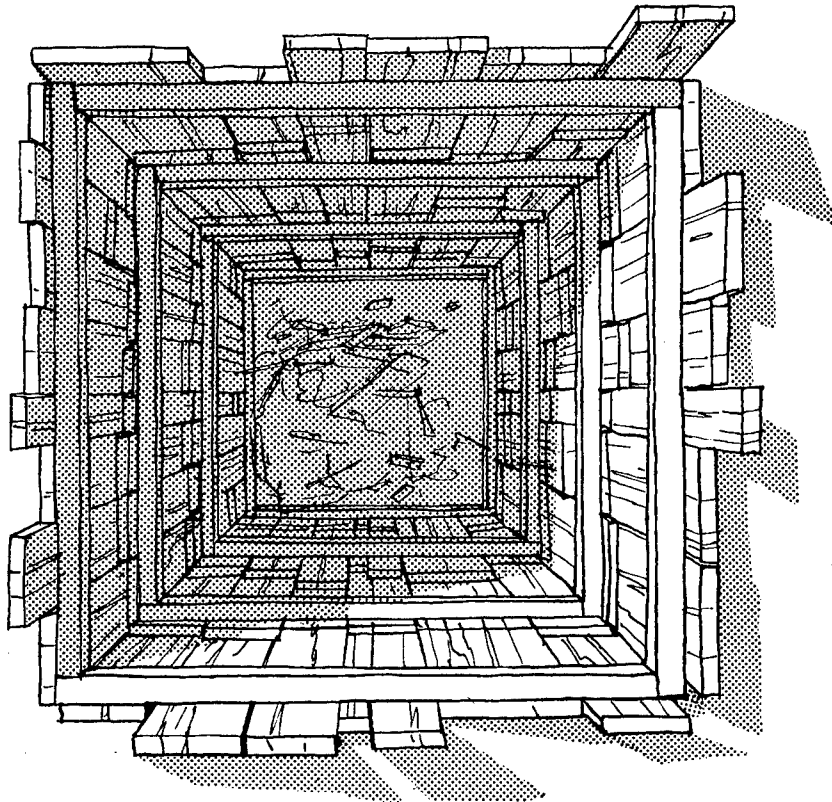

FIGURE 25.—Shaft.

MAIN TOPICS	TEACHING POINTS
-------------	-----------------

A. METHOD

B. PRECAUTIONS

1. Many of the principles and cautions of tunneling apply to shafting. The sides of the shaft must always be supported by timbering (similar to tunnel sets). The timbers should be heavy and wedged into position as tightly as possible.
1. The spot chosen for shafting should be free of service pipes or other obstructions.
2. If there is any doubt of the success of this method, an alternate method of reaching the victim should be begun simultaneously.
3. The pick-and-shovel man works in a cramped position and the work is tedious. He should not remain in the shaft any longer than necessary. The leader should consider these factors in organizing relief.
4. Rescuers charged with driving down planks should be careful they do not injure trapped persons or cause cave-ins.
5. Debris buckets should be lowered and hoisted carefully to prevent spilling debris on those in the shaft.

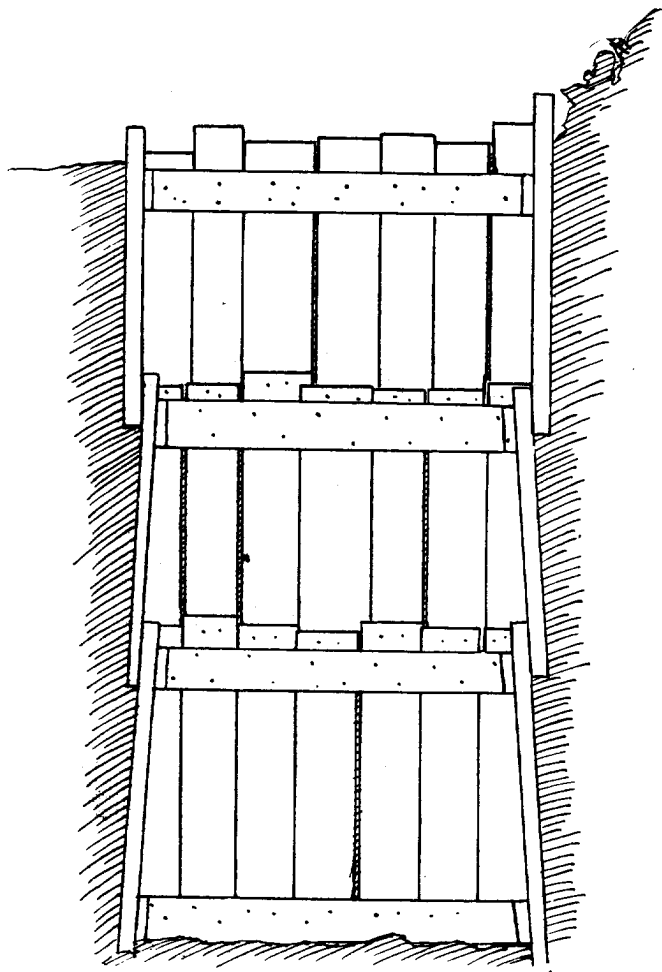

FIGURE 26.—Shaft—cross section.

STUDENT PARTICIPATION:

Trainees should do actual trenching, tunneling, and shafting under supervision of the instructor.

HANDOUT MATERIALS AVAILABLE:

None.

LESSON AIDS

10—Rescue from Heights

This lesson presents one new method of rescue, the "telpher," and the practical application of methods discussed earlier.

The telpher is efficient in that, once it is set up, many casualties found in the same level can be lowered on it at a minimum of time per casualty. The span of a telpher plus the weight it must support requires a wire cable. A manila rope is not heavy enough. It also requires good anchorage at both the lower and upper levels. The team leader must size up the situation and be sure those two points of anchorage will sustain the strain. He should attach his gear lifting tackle ("come along") at the lower anchorage and thus be in better position to detect any overstrain on the member to which he anchors the telpher. The knots used in securing the ropes to the stretcher must be tied carefully. While gravity works for rescuers in all high rescue, it can be treacherous if allowed to get out of hand. Friction is the best brake against gravity.

The "jib" principles discussed in lesson plan No. 5 should be put into practice in this lesson.

The close-to-wall vertical lower is an extension of the principles used in Light Duty Rescue Course No. 14.2, Lesson Plan No. 4 "Rescue from Limited Heights." In heavy duty rescue, these principles are applied to multiple storied heights. The importance of friction and safe anchorage of the lowering line is equally important in this method.

The "county fair" method of instruction may be used in this presentation. Three stations should be equipped for the 3 types of rescue, and the class divided into 3 groups. An hour should be used for each phase of training.

In training on the telpher line, a dummy should first be lowered.

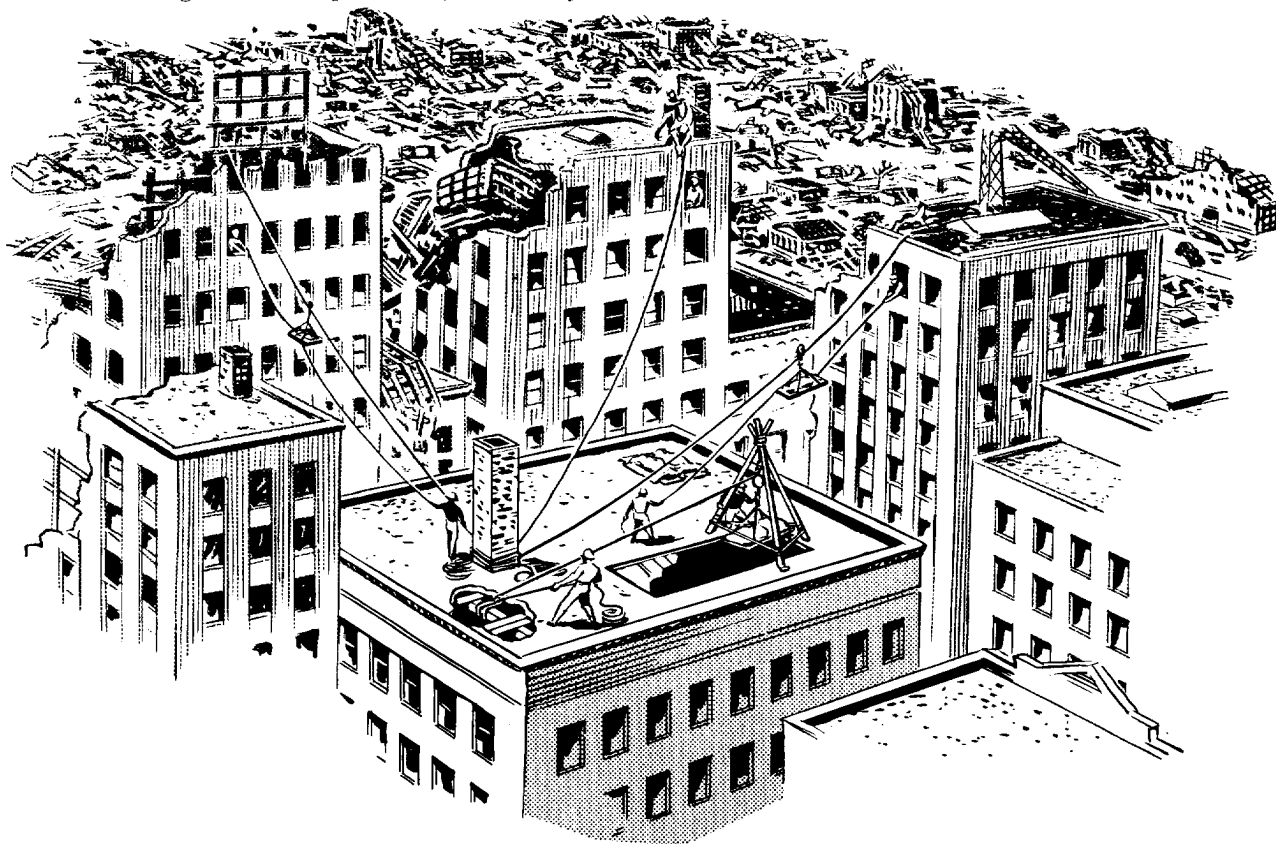

FIGURE 27.—Rescue from heights—Telpher.

LESSON PLAN NO. 10

COURSE: Heavy Duty Rescue—Course No. 14.3
 LESSON TITLE: Rescue from Heights

TIME: 3 hours

TRAINING MATERIALS:

Telpher-----	One wire cable, 3/8-inch by 150 feet. One gear lifting tackle ("come along"). Proper anchorage. One Stokes stretcher. Two blankets. One snatch block. Two 1/2-inch by 200-foot ropes. One 1/2-inch by 50-foot rope.
Jib Arm-----	One pole or timber, 4 by 4 inch (8 to 16 feet long). One set block and tackle. Three 1/2-inch by 50-foot lashing ropes. Marline or twine for mousing. One 3/4-inch by 150-foot rope. One stretcher. Two blankets.
Close-to-Wall-----	One 3/4-inch by 150-foot rope.
Vertical Lower-----	Three 1/2-inch by 50-foot ropes. One stretcher. Two blankets.

REFERENCES:

- Rescue Techniques and Operations*, FCDA, TM-14-1.
- Basic Rescue Course*, FCDA, IG-14-1, Lesson Plan No. 6.
- Light Duty Rescue*, FCDA, IG-14-2, Lesson Plan No. 4.
- Heavy Duty Rescue*, FCDA, IG-14-3, Lesson Plan No. 5.

MOTIVATION:

Many casualties will be trapped in places higher than the third story. Rescue from such heights can be extremely dangerous unless proper rescue techniques are followed. This lesson prepares rescuers for such jobs and attempts to instill in them the necessary confidence.

MAIN TOPICS	TEACHING POINTS
A. OBJECTIVES	1. Knowledge of techniques of high rescue. 2. Utilization of the skills and techniques learned thus far in the course. These include: a. Leadership. b. Reconnaissance and decisions. c. Casualty handling. d. Use of rope. e. Use of ladders. f. Lashing and rigging. 3. To introduce one item of new equipment—wire cable.

MAIN TOPICS

TEACHING POINTS

B. TYPE OF RESCUE

1. The type of rescue depends on the leader's decision as a result of careful analysis of the problem. Before deciding on the method of rescue, the leader should consider the following:
 - a. Total number and location of known casualties.
 - b. Condition of casualties and injuries.
 - c. Status of team training and skills represented.
 - d. Available equipment for operation. What he can do with what he has.
 - e. Conditions of structures (stability).
 - (1) Anchorage points.
 - f. Presence and condition of elevator shafts or stairways.
2. The leader should also:
 - a. Take advantage of gravity.
 - b. Remember that friction will counteract gravity.
 - c. Consider the time needed for setting up the equipment—justification in terms of numbers.
 - d. Not sacrifice *speed with care* for speed.

C. METHODS

1. Telfer line (used only when properly equipped).

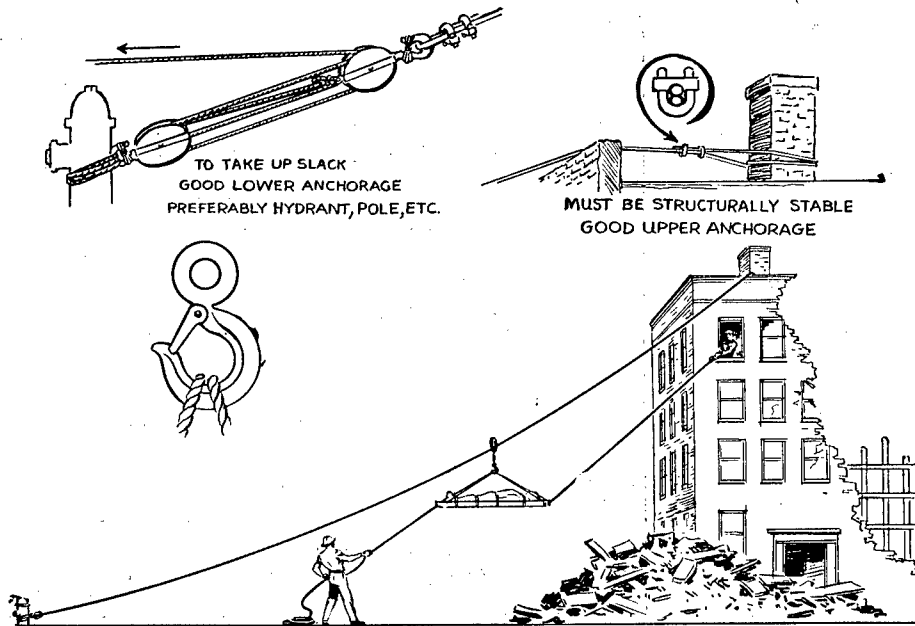

FIGURE 28.—Telfer line.

- a. Preparation.
 - (1) Equipment.
 - (2) Proper anchorage.
 - (3) Manpower distribution.
- b. Cautions.
 - (1) Use properly weighted dummy for first lower.
 - (2) Remember principles of gravity.
 - (3) Employ principles of friction.
 - (4) Be sure of all anchors.
 - (5) Lower stretcher slowly.

MAIN TOPICS

TEACHING POINTS

C. METHODS—Con.

- c. Setting up telpher. (See figure 28.)
 - (1) Secure upper anchorage.
 - (2) Secure lower anchorage.
 - (3) Take slack out (block and tackle or "come along").
 - (4) Place safety snatch block on telpher line.
 - (5) Place stretcher sling on snatch block.
 - (6) Secure hold back line to stretcher, not to block.
 - (7) Pass forward guide line to man on ground.
 - (8) Lower stretcher slowly on telpher.
2. Jib arm with whip (single sheave block), or block and tackle.
 - a. Review principles of Lesson Plan No. 5 for erection of jib.
 - b. Make preparations and observe cautions listed for telpher line.
 - c. Setting up. (See figure 16.)
 - (1) Prepare jib with whip or block and tackle.
 - (2) Put assembled jib in place, including lowering line with figure-eight as stopper.
 - (3) Prepare and attach stretcher to stoppered end of lowering line. Be sure that lowering anchor is snubbed with at least one full turn and properly secured for weight on line. Put guide rope on stretcher.
 - (4) Take up slack and clear stretcher from window.
 - (5) Pay out line slowly. To prevent override or bind at point of snubbing, keep about six inches between feedline and loadline. (See snubbing, figure 29.)
3. Close-to-wall vertical lower.
 - a. Make preparations and observe cautions listed in section on telpher method.
 - b. May be either same level or upper level suspension.

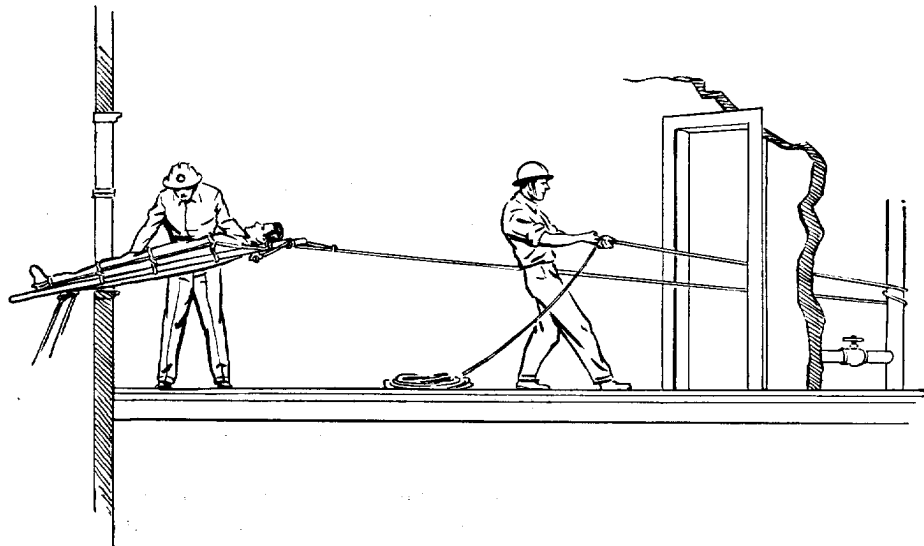

FIGURE 29.—Close-to-wall vertical lower.

MAIN TOPICS	TEACHING POINTS
C. METHODS—Con.	<ul style="list-style-type: none"> c. Same level suspension. <ul style="list-style-type: none"> (1) Prepare stretcher for lowering. Attach guidelines. (2) Secure lowering line to head of stretcher through D's. (See <i>Basic Rescue Course</i>, Lesson Plan No. 6, figure 16.) (3) Anchor lowering line to snub point (at least one full turn on snub). Allow slack to reach window. (4) Place stretcher, foot first, on window sill. (5) Ease stretcher out window, taking particular care that snubman has full control and guideline men keep stretcher from spinning or scraping wall. (6) Lower slowly, paying out line through snub as for jib arm lowering. 4. Other methods. <ul style="list-style-type: none"> a. Make preparations and observe cautions listed in section on telpher method. b. Review ladder slides, basket, and others given in <i>Light Duty Rescue Lesson Plan No. 4</i>, using the longer extension ladders included in heavy rescue equipment. Adapt these techniques to high rescue. c. Explain application of all methods to such specific problems as escalators, shaftways, and stairways.

STUDENT PARTICIPATION:

Trainees will practice the four types of rescue under supervision of the instructor, striving for proficiency.

HANDOUT MATERIALS AVAILABLE:

None.

LESSON AIDS

11—Radiological Defense Instrument Familiarization

This 2-hour lesson is intended to familiarize rescue personnel with the radiation detection instruments that will be used following a nuclear attack. It does not qualify these men as radiological monitors able to make operational decisions. Radiological monitors must take a separate course.

Safety Precautions—The radiation sources used are cobalt-60 gamma ray emitters. They should never be allowed to come into contact with the body, and should be handled only with metal tongs specially designed for such use.

During this session students will receive much less than the 0.3 roentgen gamma-ray exposure, which is the industrial maximum permissible dose for weekly continuous exposure.

The instructor should keep a record of each class member's exposure as indicated by the reading on the personal dosimeter issued to him.

Instructor Qualifications—To assure proper handling of the radiation sources and student safety, instructors should meet the following criteria: have had formalized training in the theory and problems of ionizing radiation; have had practical experience in handling radiation sources; and have been approved by the Atomic Energy Commission for handling such sources.

The instructor should devote the first 45 minutes to an explanation of radiation and the instruments used in detecting it, making sure the class understands the subject before beginning the practical exercise.

Four stations should be set up in advance for the practical exercise, far enough apart to avoid confusion. The class should be divided into groups, each assigned to Station II, III, or IV.

Station I—Use of dosimeter. The entire class should assemble at Station I. Under the supervision of the instructor, each member should charge a dosimeter to zero, using Charger CD-V-750. After the dosimeters have been zeroed, the trainees should place them on the 18- and 36-inch circles, take readings every 15 minutes, and record them. (Review directions on instruction sheet for Station I.)

When the exercise at Station I is completed, each group should report to its assigned station. Work at each of these stations requires approximately 30 minutes. At half-hour intervals the groups should rotate to another station until all groups have worked at all 3 stations.

Much of the success of this lesson will depend on how well the instructor has organized and prepared for it. If possible, assistant instructors should be in charge of each of the four stations. If he has no assistants, the instructor must be more thorough in his discussion of instruments and also very careful that all students know exactly where to report after the conclusion of practical work at Station I. If not possible, the instructor should designate a member of each group as group leader. He should also reproduce copies of the instruction and data sheets for each member of the class. Written examinations are not recommended.

Station II—Use of Geiger counter survey meter. Readings should be taken at four distances from the source—at the semicircle lines drawn at 45, 30, 15, and 3.5 feet. (Review directions on instruction sheet for Station II.)

Station III—Discrimination between beta and gamma. This exercise is designed to give trainee experience in testing contaminated food and water. (Review directions on instruction sheet for Station III.)

Station IV—Ionization chamber survey meter. Medium range, gamma only. The same cobalt source may be used as for Station II by arranging 9- and 18-inch semicircles from the opposite side, as in figure 30. (Review directions on instruction sheet for Station IV.)

STATION 1

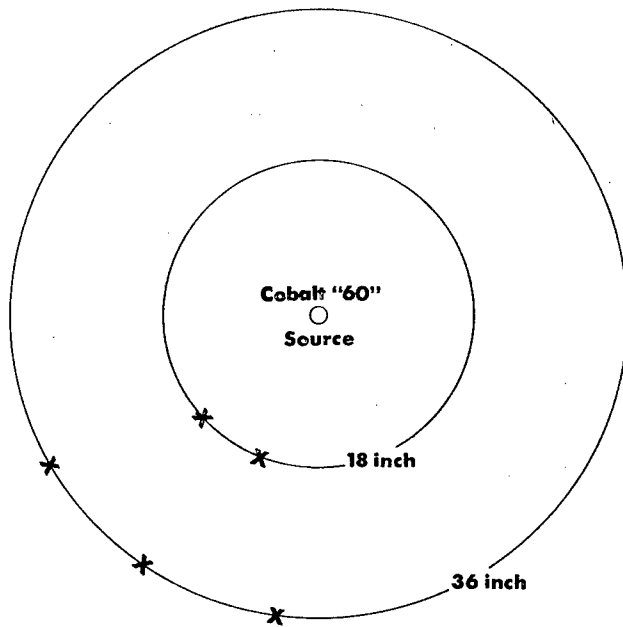

STATION 2 (Geiger Counter CD V-700)

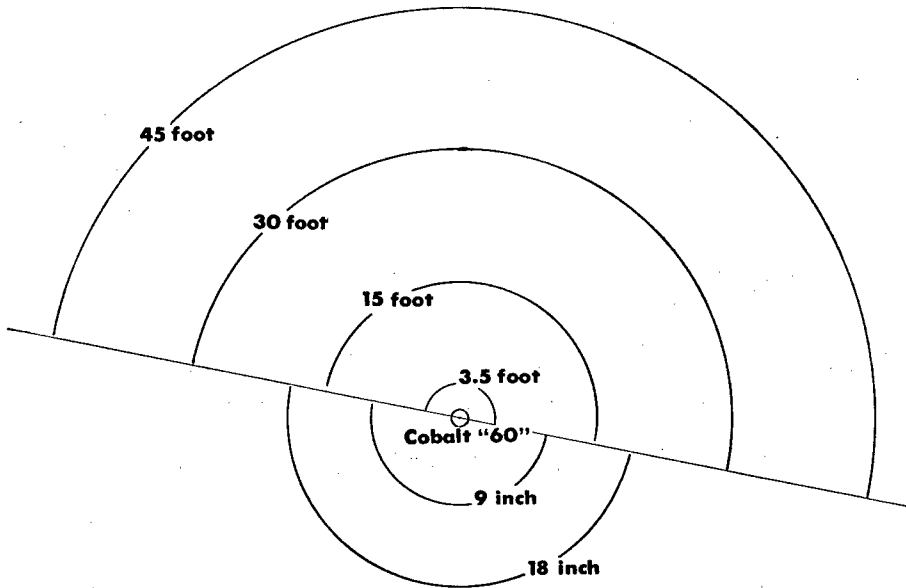

STATION 4 (Ion Chamber CD V-710)

FIGURE 30.—Radiological monitoring stations.

INSTRUCTION SHEET

STATION I

A. Dosimeter familiarization. (Dosimeter CD V-138, 200 mr; charger, CD V-750.)

DIRECTIONS:

1. Place dosimeter on charging contacts of charger.
2. Depress firmly to assure proper electrode contact. Look through the dosimeter while it is in depressed position on the charging contacts.
3. Pulse the charger or "down scale" position until the hairline becomes visible in the dosimeter and moves across the scale, right to left. The hairline will then be left of zero.
4. Hold the knob on "discharge" or "up-scale" position until the hairline moves slowly to the right—stopping it on the "zero" position. The dosimeter is now fully charged. Any ionizing radiation you receive during the course of the other exercises will be measured by the dosimeter. The total amount of radiation you have received since charging the dosimeter may be read at any time from the milliroentgen scale visible inside the dosimeter.

B. Use of dosimeters. (CD V-138, 0-200 mr dosimeter.)

DIRECTIONS:

1. Taking 2 of the dosimeters that were charged, place them on the semicircle at the points indicated. These points are 18 and 36 inches from the radiation source.
2. Note the time the dosimeters are placed in position, record the readings at the end of 15, 30, and 45 minutes as indicated by the data sheet.

STATION II

Survey meter familiarization. (CD V-700, Geiger counter, low range, beta-gamma discriminating.)

DIRECTIONS:

1. Attach head phone to the instruments. Each click you hear is the result of one single ionizing event in the Geiger tube. Since there are too many clicks to count in even a low intensity radiation field, you will notice that the meter is calibrated in mr/hr (milliroentgens per hour) on the upper section of the dial.
2. Leaving the headphones attached, turn the switch to the x10 position, open the beta shield over the Geiger tube and place the *open* side of the probe next to the nameplate on the side of the instrument case. (This metal nameplate contains a weak beta source.) Note the increased number of clicks from the headphones as the probe approaches the nameplate.
3. Turn the instrument *off* and remove the headphones. Take it to the work area and continue.
4. Turn the setting knob to the x100 position and approach the line marked 45 feet. Keeping the probe perpendicular to the radiation source and waist high, increase the instrument sensitivity to (x10 or x1 scale), until a meter reading is possible. Record the scale used and the meter reading on the data sheet. Repeat the operation at each distance indicated by the data sheet.

WARNING:

If the needle moves off the calibrated portion of the dial to the right, reduce the instrument sensitivity immediately (i. e.—switch from x1 to x10, or x10 to x100, etc.).

STATION III

Discriminating between beta and gamma. (Use CD V-700 Geiger counter, low range, beta-gamma discriminating.)

DIRECTIONS:

1. With the window on the probe open, place the probe on top of the container holding the radioactive source. This measures both the gamma and beta radiation. Record the scale used and the meter reading.
2. Repeat with the window closed and the probe in the same position over the container. In this instance, the beta radiation is cut out. Record this reading.
3. Is there a difference in the readings? If so, record the difference as the beta reading.

NOTE: Be sure to turn the instrument *OFF* when you are through with it.

STATION IV

Survey meter familiarization. (CD V-710, ion chamber, medium range, gamma only.)

DIRECTIONS:

1. Turn switch to "battery check" or "circuit check" position. The needle should move to the "battery check" or "circuit check" position on the meter dial.
2. Now turn the selector knob to "zero." Allow the instrument to warm up about three minutes. Then bring the needle to rest on "0" by adjusting the small "zero" knob under the handle.
3. Carry the CD V-710 toward radiation source, with scale setting starting on the x100 and increasing sensitivity to x10 or x1 until you get a reading. Take 2 readings, 1 with the instrument at 18 inches and 1 at 9 inches from the source. Record the readings on the data sheet.

LESSON PLAN NO. 11

COURSE: Heavy Duty Rescue—Course No. 14.3

LESSON TITLE: Radiological Defense Instrument Familiarization

TIME: 2 hours

TRAINING MATERIALS:

- Blackboard, chalk, eraser.
- Fifty-two 0-200 mr self-reading dosimeters (V-138).
- Three dosimeter chargers (V-750).
- Thirteen Geiger counters (V-700).
- Thirteen medium range survey meters (V-710).
- Gamma ray sources, cobalt-60.
- Comparison standard.

REFERENCES:

- Development Status of Personal Dosimeters*, FCDA, TB-11-4.
- Emergency Exposure to Nuclear Radiation*, FCDA, TB-11-1.
- Health Services and Special Weapons Defense*, FCDA, AG-11-1.
- Personal Dosimeters for Radiological Defense*, FCDA, TB-11-2.
- Protection from Fallout Radiation*, FCDA, TB-11-19.
- Radiation Physics and Bomb Phenomenology*, FCDA, TB-11-22.
- Radiological Instruments for Civil Defense*, FCDA, TB-11-20.
- The Most Promising Personal Dosimeters for Civil Defense Use*, FCDA, TB-11-3.

MOTIVATION:

People fear what they do not understand. Rescuers should not allow fear of radiation to affect their operations. One person, either a member of the rescue squad or of another civil defense service attached to the squad, should be on the scene to read radiological instruments.

MAIN TOPICS	TEACHING POINTS
A. PURPOSE	<ol style="list-style-type: none"> 1. Familiarize students with radiation. 2. Familiarize students with radiation detection instruments. 3. Explain need for monitoring skills.
B. RADIATION PROBLEM	<ol style="list-style-type: none"> 1. What is radiation? <ol style="list-style-type: none"> a. The giving-off of energy in some form. 2. What is nuclear radiation? <ol style="list-style-type: none"> a. Nuclear radiation is giving off of energy from the nuclei of atoms. Nuclear radiation comes off in three forms: alpha particles, beta particles, and gamma rays. <ol style="list-style-type: none"> (1) Initial nuclear radiation is given off for about one minute from the moment of explosion. (2) Residual nuclear radiation is caused by radioactive contamination created by a nuclear explosion and persists for some time. b. <i>Alpha particles</i> have a very short range only a few inches in the air. Their penetration is very low and can be stopped by a sheet of paper. Alpha particles are dangerous internally but harmless externally. c. <i>Beta particles</i>, like the alpha particles, also have a short range—a few feet—and are dangerous internally. They can be stopped by 1/8 inch

MAIN TOPICS	TEACHING POINTS
<p>B. Radiation Problem— Continued</p>	<p>of aluminum or its equivalent. They present a serious problem to rescuers working among debris.</p> <p>d. <i>Gamma rays</i> are similar to X-rays but have shorter wave lengths which make them very penetrating. Their range varies with energy. Lead shielding will reduce their intensity, but some radiation always gets through. Gamma rays, because of their penetration, are more dangerous than the other two.</p> <p>e. <i>Radioactive</i> decay refers to the disintegration of radioactive nuclei associated with the emission of radiation.</p> <p>f. <i>Half-life</i> is the time it takes for a specific radioactive element to lose half its intensity. Half-lives range from seconds to millions of years, depending on the element.</p> <p>g. <i>Roentgen</i> refers to the basic unit by which nuclear radiation is measured, just as the degree is used in measuring temperature or the watt, electricity. Total dose may be measured either in roentgens or milliroentgens (r or mr).</p>
<p>C. INSTRUMENTS</p>	<p>1. Survey meters:</p> <p>a. <i>Geiger counter</i> (CD-V-700). This is a low range (0-50 mr/hr) instrument particularly designed for food, water, personnel monitoring, and training. A window in the probe makes it possible to discriminate between beta and gamma radiation. The instructor should display the instrument to the class and point out its features.</p> <p>b. <i>Ionization chamber</i> (CD-V-710) is a medium range (50 r/hr) instrument designed for area monitoring as well as aerial survey. The instructor should follow the same procedure as in presenting the Geiger counter.</p> <p>c. <i>Ionization chamber</i> (CD-V-720) is a high range (500 r/hr) instrument designed for use in areas of high intensity contamination and in making beta readings. (See TB-11-20.) The instructor should follow the same procedure as in presenting the other meters.</p> <p>2. <i>Dosimeter</i>. This instrument looks like a fountain pen; it is worn on the person and is for personal protection. It measures the total amount of gamma radiation which passes through its ionization chamber or that part of the body where it is worn. It indicates readings in mr or r and shows total dosage. (It may be compared to an odometer register in an automobile's speedometer.) At the clip end of the dosimeter is the eyepiece; under this is a lens focused on a semitransparent scale fixed in the tube. Under the scale is a very small quartz fiber electroscopes. At the end opposite the eyepiece is a small window. By looking through the eyepiece and holding the window toward the light, the scale may be seen. The amount of radiation dosage reached is indicated by the hairline across the scale. The hairline is actually the quartz fiber of the electroscopes which moves across the scale as the electroscopes is discharged by the action of the gamma rays passing through the ionization chamber.</p>

MAIN TOPICS	TEACHING POINTS
C. INSTRUMENTS—CON.	<p>a. Three models of dosimeters are recommended by FCDA:</p> <ol style="list-style-type: none"> (1) <i>Training</i>: CD-V-138, a low range instrument used for training purposes, registers dosages up to 200 mr. (2) <i>Operations</i>: CD-V-730 measures total dosage in roentgens up to 20. CD-V-740 measures total dosage up to 100 roentgens. <p>b. <i>Dosimeter charger</i> (CD-V-750) is used to zero the dosimeter prior to its use. The procedure is as follows:</p> <ol style="list-style-type: none"> (1) Place dosimeter on charging contacts of charger. (2) Depress firmly to assure proper electrode contact. Look through the dosimeter while it is in depressed position on the charging contacts. (3) Pulse the charger or "down scale" position until the hairline becomes visible in the dosimeter and moves across the scale, right to left. The hairline will then be <i>left</i> of zero. (4) Hold the knob on "discharge" or "up scale" until the hairline moves slowly to the right—stopping it on the zero position. The dosimeter is now fully charged. The total amount of radiation received since charging the dosimeter may be read at any time from the milliroentgen scale visible inside the dosimeter.
D. SOURCES	<p>For Stations I, II, and IV use a 15 mc cobalt-60 source, and for Station III use comparison standard.</p>
E. CONCLUSION	<p>1. Rescuers should know:</p> <ol style="list-style-type: none"> a. Location of contaminated area. b. Kind of radiation. c. Amount of radiation. This is a determining factor in the length of time rescuers will be permitted in an area.

STUDENT PARTICIPATION:
 Three-fourths of the period should be allotted to the practical exercise.

HANDOUT MATERIALS AVAILABLE:
 None, aside from material within this lesson plan, which the instructor may reproduce for distribution to class.

DATA SHEET

INSTRUMENT FAMILIARIZATION PROGRAM

RADIOLOGICAL DEFENSE

(Practical Exercise)

Date:

CD V-700 Serial No.

Name:

CD V-710 Serial No.

Address:

CD V-138 Serial No.

Station I—Use of CD V-138 (0-200 mr dosimeter)

Distance	Time	Reading
18''	15m	
18''	30m	
18''	45m	

Distance	Time	Reading
36''	15m	
36''	30m	
36''	45m	

Station II—Use of CD V-700 (Geiger Counter Survey Meter)

Distance	Scale Used	Meter Reading	Actual Dose-Rate (Scale x Meter Reading)
45 ft.			
30 ft.			
15 ft.			
3.5 ft.			

Station III—Discrimination Between Beta and Gamma (Use CD V-700)

Radiation	Scale	Meter Reading	Actual Dose-Rate (Scale x Meter Reading)
Beta and Gamma			
Gamma			
Beta			

Station IV—Use of CD V-710 (Ionization Chamber Survey Meter)

Distance	Scale Used	Meter Reading	Actual Dose-Rate (Scale x Meter Reading)
18''			
9''			

LESSON AIDS

12—Planning for Night Exercise

13—Night Exercise

14—Critique of Exercise

This course is not complete without a night exercise which tests the class in everything that has been taught. Such an exercise is also an aid to the instructor in evaluating his teaching effectiveness.

Exercises, particularly those involving other services, should resemble an actual disaster incident as much as possible. An atmosphere of desolation and confusion, with masses of debris and real people simulating casualties, will add realism.

Before the exercise the instructor should explain the following: purpose, lessons to be learned, and general nature of the problems to be tackled. He should not reveal too much of what is planned. The reason for the exercise—testing the trainees—should not be sacrificed because the instructor wants his class to make a good showing. Although the exercise should be open to the public as part of the civil defense public education program, it is not intended as entertainment.

Time is allotted in the schedule for a thorough critique of individual work during the exercise. Class members should be told before the exercise that there will be such a critique, and that its purpose is constructive.

LESSON PLAN NO. 12

COURSE: Heavy Duty Rescue—Course No. 14.3

LESSON TITLE: Planning for Night Exercise

TIME: 1 hour

TRAINING MATERIALS:

None.

REFERENCES:

Light Duty Rescue Course, No. 14.2, Lesson Plan No. 8, Casualty Simulations.

All notes and handout materials accumulated during the course.

MOTIVATION:

Rescue trainees should know how to plan a night exercise for subsequent training of their own squads.

MAIN TOPICS	TEACHING POINTS
<p>A. OBJECTIVE</p> <p>B. SCOPE</p>	<ol style="list-style-type: none"> 1. To present in chronological order an outline of the factors to be considered in a night exercise. 1. Purpose of exercise. 2. Date—the season of the year and the possibility of inclement weather must be considered. 3. Hour of darkness an important consideration. 4. Duration—number of hours. 5. Location—street and number. 6. Number of persons taking part. <ol style="list-style-type: none"> a. Trainees—team assignments. b. Leaders—selection of squad, deputy squad, and team leaders. <ol style="list-style-type: none"> (1) Designation or markings: <ul style="list-style-type: none"> Example: Team members—helmet color. Squad leader—3 distinct stripes on helmet. Deputy squad leader—2 distinct stripes on helmet. Team leader—1 distinct stripe on helmet. 7. Directing staff. These men should know all phases of the exercise, particularly their responsibilities and the location of casualties. The latter would be important if fire broke out or some other emergency occurred. <ol style="list-style-type: none"> a. Designation or markings for exercise director, coordinator, wardens, and umpires. 8. Exercise assembly points. There should be a designated assembly point for each participating service. 9. Briefing of service chiefs. 10. Clothes for exercise. Announcement of dress for trainees and directing staff members. 11. Termination of exercise. Either a specified time, or as soon as all casualties are cleared and reported. The exercise should not run over 3 hours.
<p>C. CASUALTIES</p>	<ol style="list-style-type: none"> 1. Preparation of casualties. 2. Briefing of casualties. They must be able to act the role as well as look the part. They should be rehearsed. Instructor should explain who they are supposed to be, the circumstances in which they are found and

MAIN TOPICS	TEACHING POINTS
C. CASUALTIES—Con,	<p>suggest the conversation between them and rescuers. All conversation must tie in together, with a definite purpose in mind.</p> <p>Example 1:</p> <ol style="list-style-type: none"> Name: casualty's own. Location: Trapped under counter in shop. Injuries: Head; conscious. Conversation: Rescuer will ask whether Mr. Mathews is all right. Casualty will say Mr. Mathews called for cigarettes and said he was going on to the local tavern. <i>If asked</i> about Mrs. Mathews, casualty should say he knows nothing, thinks she will be in the house. Later on arrival at first aid station casualty should say he remembers that Mrs. Mathews is visiting friends in a nearby city, and asks the first aid people to tell the warden about this. <p>Example 2:</p> <ol style="list-style-type: none"> Name: Casualty's own. Location: Trapped against rear wall, in first floor room (right or left side). Injuries: Broken leg and slight concussion. Unconscious at start, will recover after being located. Conversation: If asked for name casualty should give it. If questioned further he should say he lives at (his own address) and was calling on Sam Mathews; had just arrived when the house seemed to collapse; has not seen Mathews as he was just ringing the bell when everything happened. Casualty's only concern: Will rescuers tell his wife what has happened and where he will be taken? She is away from home. Casualty should give no further information.
D. ONLOOKERS	<ol style="list-style-type: none"> The public should be permitted to watch the exercise but kept away from the working area and not allowed to interfere with rescue operation. Nuisances and debris crawlers, if used in the exercise, should be carefully rehearsed. Without proper rehearsal they may tend to overact.
E. COMMUNICATIONS	<ol style="list-style-type: none"> Brief trainees on methods of communication to be used in the exercise.
F. CONCLUSION OF BRIEFING	<ol style="list-style-type: none"> Clarify questions on exercise. Synchronize watches. Allow trainees to make final preparations.

STUDENT PARTICIPATION:

- Questions and answers.
- Final preparation for exercise.

HANDOUT MATERIALS AVAILABLE:

None.

CHECKLIST
RESCUE EXERCISE

Date.....

Team 1
Jones 8 Men
 Leader Deputy

Observer.....

	Very Good	Good	Fair	NOTES
Leadership:				
1. Knowledge of rescue.....	✓			<i>Good decision</i>
2. Issuance of orders.....		✓		<i>#8 man was not present when you issued orders.</i>
3. Control of manpower.....	✓			
4. Use of manpower.....	✓			<i>Every man was working</i>
5. Delegate authority.....		✓		
6. Coordination of services.....		✓		
Reconnaissance:				
1. Initial.....	✓			
2. Silence period.....			✓	<i>Some insisted on talking which confused the leader</i>
3. Stages of rescue.....	✓			
4. Continuity.....	✓			
5. Fire prevention.....			✓	<i>Forget about taking a fire extinguisher when rescuing casualties</i>
Skills:				
1. Knots.....	✓			
2. Lashings.....	✓			<i>Best I've seen</i>
3. Lifting and rigging.....		✓		
4. Confined spaces.....	✓			<i>Did not allow men to remain in confined spaces too long</i>
5. Stretchers, etc.....	✓			
6. First aid.....	✓			
7. Protective breathing.....		✓		
8. Rescue from heights.....			✓	<i>When leader talks men should pay strict attention</i>
Equipment:				
1. Issuance.....		✓		
2. Care.....		✓		
3. Safety.....		✓		
4. Use of emergency medical tags.....			✓	<i>Forget to tag Casualty # 2</i>

LESSON PLAN NO. 14

COURSE: Heavy Duty Rescue—Course No. 14.3

LESSON TITLE: Critique of Exercise

TIME: 1 hour

TRAINING MATERIALS:

Checklist for rescue exercise.

REFERENCE:

None.

MOTIVATION:

Class members should know whether what they did was right or wrong, and why.

MAIN TOPICS	TEACHING POINTS
A. PURPOSE	<ol style="list-style-type: none">1. Excellent source of technical information for trainees.2. Opportunity to learn what mistakes were made.3. Opportunity to learn better approaches.4. Opportunity for trainee to explain his actions.
B. PREPARATION	<ol style="list-style-type: none">1. The one charged with umpiring a team's actions should:<ol style="list-style-type: none">a. Prior to exercise, learn problem.b. Know all the possible approaches and solutions to each incident.c. Know which approach or solution the instructor favors as most effective. His critique remarks must be pointed toward these.d. Know what training the class has been given during the course.e. Know the items in the checklist.

STUDENT PARTICIPATION:

100 percent.

HANDOUT MATERIALS AVAILABLE:

None.

**CHECKLIST
RESCUE EXERCISE**

Date.....

Team.....

Observer.....

Men

Leader

Deputy

	Very Good	Good	Fair	NOTES
Leadership:				
1. Knowledge of rescue.....				
2. Issuance of orders.....				
3. Control of manpower.....				
4. Use of manpower.....				
5. Delegate authority.....				
6. Coordination of services.....				
Reconnaissance:				
1. Initial.....				
2. Silence period.....				
3. Stages of rescue.....				
4. Continuity.....				
5. Fire prevention.....				
Skills:				
1. Knots.....				
2. Lashings.....				
3. Lifting and rigging.....				
4. Confined spaces.....				
5. Stretchers, etc.....				
6. First aid.....				
7. Protective breathing.....				
8. Rescue from heights.....				
Equipment:				
1. Issuance.....				
2. Care.....				
3. Safety.....				
4. Use of emergency medical tags.....				

TIPS FOR MAINTAINING SQUAD INTEREST IN TRAINING AFTER THE COURSE

Graduation from a rescue course such as 14.3 should not end the activities of the group. The squad should be held together and continue its training as a unit. This can be accomplished only by:

1. *Good leadership.*—Leaders who have the respect of the members, believe in the program, and are willing to devote time to further training.

2. *Proper attitude of squad members.*—They must be completely sold on the program and willing to devote time for further training.

3. *Esprit de corps.*—Pride of belonging to a unit will be shown by enthusiasm and devotion to duty.

4. *A well worked out continuance training program.*—The squad leader should plan a program which will best keep the members in condition of readiness for an emergency. The program should be instructive and interesting. Interesting does not mean entertaining. The program should be flexible. For example, if the weather is too bad for scheduled outdoor training, the squad leader should substitute a classroom period and show a rescue film. This should be followed by a general discussion of rescue problems.

Rescue workers appreciate recognition of their training. Squad leaders should arrange for local newspaper publicity. Inviting city officials to visit the training center is a good way to publicize its activities.

Attendance records should be kept by someone in the squad, and absence without a good excuse should not be tolerated. Team leaders should be responsible for their team attendance and participation. The items in a training schedule should be determined by priority of need. Skills in which the squad is weakest should be first.

FILMS

The films in this list are official FCDA motion pictures and films on civil defense subjects produced independently but approved by FCDA. All are 16 mm.

To purchase prints, write directly to the source of supply which is coded as follows:

- Code A—Byron, Inc.
1226 Wisconsin Ave. NW.
Washington 7, D. C.
- Code B—Capital Film Laboratories
1905 Fairview Ave. NE.
Washington, D. C.
- Code C—Robert J. Enders, Inc.
1001 Connecticut Ave. NW.
Washington, D. C.
- Code D—Office of Civil Defense
Mobile, Ala.

Prices are for single orders and include reel, can, and fiber shipping case unless otherwise indicated. To obtain preview copies of any of these films, contact your State civil defense office or nearest FCDA regional office.

"TRAPPED" (Code A)

Price: Black & white.....	\$35.37	Time: 20 minutes	Released
Produced by FCDA		Cleared for TV	Feb. 1954

Adaptation of a Swedish rescue film, with English narration. It emphasizes the need for trained rescue workers and shows some of the risks of rescue, as well as some of its rewards. It also shows many of the special techniques required to rescue trapped casualties: searching in collapsed structures, digging through rubble, tunneling through shifting masses of debris, and wall breaching.

"THE HOUSE IN THE MIDDLE" (Code A)

Price: Black & white.....	\$12.38	Time: 6½ minutes	Released
Produced by FCDA		Cleared for TV	Oct. 1953

Shows three small houses used in official fire tests at the Atomic Energy Commission's Nevada Proving Ground. The house in the middle withstands the fire effects of the atomic burst because it is free of litter and trash, properly painted, and made of good materials. The houses on either side are completely destroyed by fire as a result of their rundown, badly weathered condition, and the trash accumulation around one of them. The value of good household fire prevention habits is brought home to the viewer in a dramatic stop-motion sequence made during the actual atomic test explosion.

"LET'S FACE IT" (Code A)

Price: Black & white.....	\$24.13	Time: 13½ minutes	Released
Color.....	47.09		Aug. 1955
Produced by FCDA		Cleared for TV	

One of the most effective civil defense films dealing with the effects of atomic explosions on homes and various industrial structures and installations. Produced at the Atomic Energy Commission's Nevada Proving Ground.

"OPERATION IVY" (Code A)

Price: Black & white.....	\$46. 21	Time: 28 minutes	Released
Color.....	93. 60		Mar. 1954
Produced by USAF		Cleared for TV	

The first public film release of the hydrogen bomb tests in the Pacific in 1952.

"OPERATION SCAT" (Code D)

Price: Black & white.....	\$19. 75	Time: 11 min. 23	Released
		sec.	1954
Produced by Mobile, Alabama, Civil Defense Office		Cleared for TV	

Film documentary of the Nation's first "driveout" depicts the rapid and orderly evacuation of approximately 480 square blocks of Mobile, Alabama, during the nationwide "Operation Alert" civil defense test in 1954. Prints are available for purchase direct from the Mobile, Alabama, Civil Defense Office.

"A NEW LOOK AT THE H-BOMB" (Code A)

Price: Black & white.....	\$17. 54	Time: 10 minutes	Released
Color.....	35. 32		Feb.1955
Produced by FCDA		Cleared for TV	

Features Federal Civil Defense Administrator Val Peterson, who explains simply and graphically the dangers of radioactive fallout and preventive measures which can be taken for individual protection. The film includes references to both evacuation and shelter as circumstances may dictate.

"ESCAPE ROUTE" (Code B)

Price: Black & white.....	\$13. 00	Time: 13½ minutes	Released
Color.....	47. 98		Aug.1955
Sponsored by the National Automobile Dealers Association		Cleared for TV	

Displays the family car in a new light explaining its value in providing radio contact with civil defense through Conelrad; space for transporting emergency family supplies; protection from the elements; and some protection against radioactive fallout.

"RESCUE STREET" (Code B)

Price: Black & white.....	\$14. 60	Time: 14 minutes	Released
Color.....	45. 56		1954
Sponsored by Reo Motors		Cleared for TV	

Follows the progress of a typical student enrolled at the FCDA Rescue Instructor Training School at Olney, Maryland. The training site, with its streets of specially constructed, partly demolished buildings, provides a realistic representation of bomb blast damage, and affords an opportunity for the demonstration of a rescue truck in civil defense rescue operation.

"OPERATION DOORSTEP" (Code A)

Price: Black & white.....	\$27. 00	Time: 10 minutes	Released
Produced by Byron, Inc.		Cleared for TV	June 1953

Emphasizes civil defense aspects of an atomic test, including preparation for the shot, placement of mannequins in cars and test houses, the convoy of test autos, before and after scenes of the test site, and a stop-motion sequence showing in detail what happened to a test house.

"TIME OF DISASTER" (Code C)

Price: Black & white.....	\$19. 75	Time: 10 minutes	Released
Produced by Robert J. Enders, Inc.		Cleared for TV	Dec. 1954

Shows civil defense in natural disasters—tornadoes, floods, hurricanes, fires, explosions—and explains the responsibilities of the Federal Civil Defense Administration and other groups.

REFERENCES

Selected FCDA Publications

These publications can be obtained from local civil defense organizations or purchased from the Superintendent of Documents, U. S. Government Printing Office, Washington 25, D. C., at nominal cost

The National Plan For Civil Defence Against Enemy Attack, 1956

Basic Rescue Course, IG-14-1, 1956

Basic Course for Civil Defense, IG-3-2, 1955.

Civil Defense Instructor's Course, IG-3-3, 1956.

Construction and Adaptation of Structures for Rescue Training, TB-14-1, December 1952

Federal Contributions Manual (including changes 1 through 12) M25-1 (Revised).

Introduction to Radioactive Fallout, IG-19-1, 1955.

Light Duty Rescue Course, IG-14-2, 1956.

Organization and Operation of Civil Defense Casualty Services, Part III—Medical Records for Casualties, TM-11-3, 1952.

Rescue Techniques and Operations, TM-14-1, 1953.

Revised Civil Defense Air Raid Instructions, Alert Signal Card, 1956.

Revised Civil Defense Air Raid Instructions, Evacuation Signal Card, 1955.

Skills Training Films (Rescue, Fire Fighting, Emergency First Aid), IG-3-1, 1954.

The Rescue Service, AG-14-1, 1951.

Other Publications

All Government publications can be purchased from the Superintendent of Documents, U. S. Government Printing Office, Washington 25, D. C., at nominal cost.

Water vs. Fire, Forest Service, U. S. Department of Agriculture, 1950.

New Method of Artificial Respiration, Bureau of Mines, United States Department of the Interior, 1952.

American Red Cross First Aid Textbook and Supplement No. 1, The Blakiston Co., Philadelphia, Pa.