

**FINAL REPORT  
MARCH 2004**

**REPORT NO. 04-13**

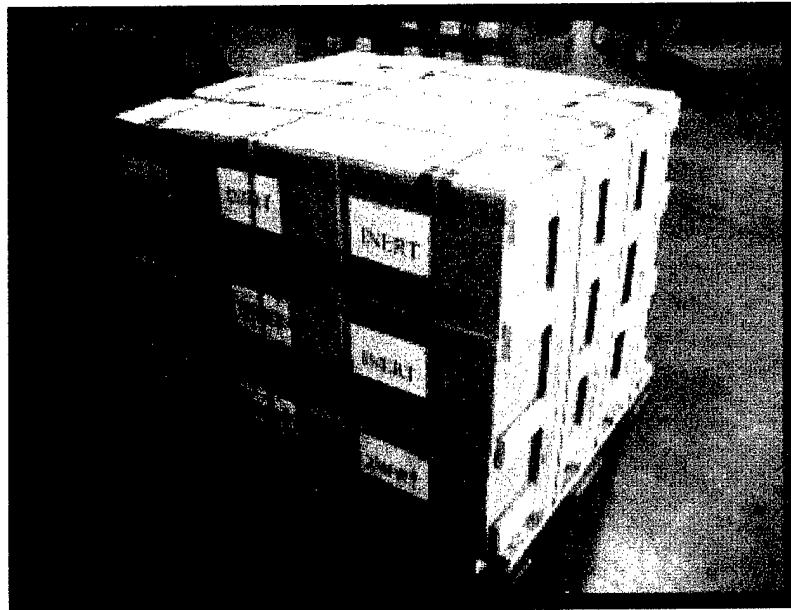

**UNITIZED POLISH TNT FIBERBOARD BOXES  
42" X 53" WOOD PALLET,  
MODIFIED MIL-STD-1660 TEST FOR LEVEL "C"  
TRANSPORTATION AND STORAGE CYCLE**

Prepared for:

Distribution Unlimited

Alliant Tech  
Radford Army Ammunition Plant  
P.O. Box 1, Rt 114  
Radford, VA 24143-0100



**VALIDATION ENGINEERING DIVISION  
MCALESTER, OKLAHOMA 74501-9053**

**20040419 069**



REPLY TO  
ATTENTION OF

DEPARTMENT OF THE ARMY  
US ARMY DEFENSE AMMUNITION CENTER  
1 C TREE ROAD  
MCALESTER, OK 74501-9053

12 April 2004

SJMAC-DEV (70-1pp)

MEMORANDUM FOR SEE DISTRIBUTION

SUBJECT: Report No. 04-13, "Unitized Polish TNT Fiberboard Boxes on a 42" x 53" Wood Pallet," Modified MIL-STD-1660 Tests for Level "C" Transportation and Storage Cycle

1. Enclosed please find subject report dated March 2004.
2. The POC is the undersigned, SJMAC-DEV, DSN 956-8908.

FOR THE DIRECTOR:

JERRY W. BEAVER  
Chief, Validation Engineering Division

Encl  
as

DISTRIBUTION:

Commander,  
TACOM/ARDEC Logistics Research & Development Activity  
(AMSTA-AR-ASL) Al Galonski, Bldg 455, Picatinny Arsenal, NJ 07806-5001  
U.S. Army Joint Munitions Command (AMSJM-TT) Richard Nesbitt, Rock Island, IL  
61299-6000  
U.S. Army Tank-automotive Command, U.S. Army Armament Research, Development &  
Engineering Center, (AMSTA-AR-WEP) Dave Piskorik, Rock Island, IL 61299-7300  
U.S. Army Tank-automotive Command, U.S. Army Armament Research, Development &  
Engineering Center, (AMSTA-AR-WEP) Gene Farrell, Picatinny Arsenal, NJ 07806-5000  
Naval Surface Warfare Center, (Arthur Stanton, Code 715), Indian Head Division, Det Earle,  
201 Highway 34 South, Colts Neck, NJ 07722-5023

Director,  
Defense Technical Information Center, 8725 John J. Kingman Road, Suite 0944, Fort Belvoir,  
VA 22060-6218

Commandant,  
U.S. Army Ordnance Missile & Munitions Center & School  
(ATSK-CMT-Z), Redstone Arsenal, AL 35897-6095

## **AVAILABILITY NOTICE**

A copy of this report will be furnished each attendee on automatic distribution. Additional copies or authority for reprinting may be obtained by written request from:

Director  
U.S. Army Defense Ammunition Center  
ATTN: SJMAC-DEV  
1 C Tree Road, Bldg. 35  
McAlester, OK 74501-9053

## **DISTRIBUTION INSTRUCTIONS**

Destroy this report when no longer needed. Do not return.

\*\*\*

Citation of trade names in this report does not constitute an official endorsement.

\*\*\*

The information contained herein will not be used for advertising purposes.

**REPORT NO. 04-13  
UNITIZED POLISH TNT FIBERBOARD BOXES  
ON A 42" X 53" WOOD PALLET,  
MODIFIED MIL-STD-1660 TEST FOR LEVEL "C"  
TRANSPORTATION AND STORAGE CYCLE**

**MARCH 2004**

**ABSTRACT**

The U.S. Army Defense Ammunition Center (DAC), Validation Engineering Division (SJMAG-DEV) conducted modified MIL-STD-1660, "Design Criteria for Ammunition Unit Loads" for Level "C" transportation and storage on the unitized Polish TNT fiberboard box on a 42" x 53" wood pallet, which will be unitized by Alliant Techsystems, from Radford, Virginia. In short, Level "C" is defined as follows: a) Items are to be used or consumed at the first destination. b) Shock, vibration, and static loading will be encountered only during a limited transportation cycle. c) Items will be stored in a favorable warehouse environment for a temporary period of less than 6 months. d) Packing guards against the effects of expected environmental exposure during loading, unloading, or intransit delays. e) Packing is able to withstand stacking and superimposed loads during shipment and temporary storage.

There were six unitized loads that were tested due to failures. Test Units #1 and #3 utilized tension netting to unitize the boxes together. The tension netting could not withstand the repetitive shock and drop testing. The boxes had movement in excess of 7". Test Units #2 and #4 utilized steel banding (3 long side, 4 short side, 1 horizontal) and a middle gate to unitize the boxes. Test Unit # 2 passed while Test Unit # 4 failed during Repetitive Shock Testing, because the entire load shifted 3". Test Units #5 and #6 utilized steel banding (3 long side, 3 short side thru pallet slots) and two end gates. Test Units #5 and #6 passed all test requirements, of the modified test, with minimal damage to the fiberboard boxes.

As a result of the performance of the unitized load, the Unitized Polish TNT fiberboard box on a 42" x 53" wood pallet with the two (2) end gate design, can be utilized for Level "C" storage and transportation.

Prepared by:

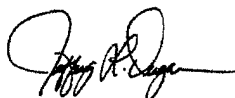

**JEFFERY L. DUGAN**  
Validation Engineer

Reviewed by:

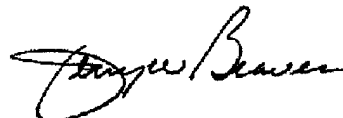

**JERRY W. BEAVER**  
Chief, Validation Engineering Division

**U.S. ARMY DEFENSE AMMUNITION CENTER**

**VALIDATION ENGINEERING DIVISION  
MCALESTER, OK 74501-9053**

**REPORT NO. 04-13**

**UNITIZED POLISH TNT FIBERBOARD BOXES  
42" X 53" WOOD PALLET,  
MODIFIED MIL-STD-1660 TEST FOR LEVEL "C"  
TRANSPORTATION AND STORAGE CYCLE**

**TABLE OF CONTENTS**

<b>PART</b>	<b>PAGE NO.</b>
1. INTRODUCTION .....	1-1
A. BACKGROUND .....	1-1
B. AUTHORITY .....	1-1
C. OBJECTIVE .....	1-1
D. CONCLUSION .....	1-1
2. ATTENDEES .....	2-1
3. TEST PROCEDURES .....	3-1
4. TEST EQUIPMENT .....	4-1
5. TEST RESULTS .....	5-1
6. DRAWINGS.....	6-1

## **PART 1 – INTRODUCTION**

**A. BACKGROUND.** The U.S. Army Defense Ammunition Center (DAC), Validation Engineering Division (SJM-DEV) conducted modified MIL-STD-1660, "Design Criteria for Ammunition Unit Loads" for Level "C" transportation and storage on the unitized Polish TNT fiberboard box on a 42" x 53" wood pallet, which will be unitized by Alliant Techsystems, from Radford, Virginia. The tests accomplished on the test units were the stacking, vibration, edgewise rotational drop, incline impact, forklift handling, and disassembly tests. These tests were accomplished in support of the ongoing effort to provide support for the movement of TNT from Poland to the McAlester Army Ammunition Plant. The unitization procedures were provided by DAC, Transportation Engineering Division (SJM-DET).

**B. AUTHORITY.** This test was conducted IAW mission responsibilities delegated by the U.S. Army Joint Munitions Command (JMC), Rock Island, IL. Reference is made to the following:

1. AR 740-1, 15 June 2001, Storage and Supply Activity Operation
2. OSC-R, 10-23, Mission and Major Functions of the U.S. Army Defense Ammunition Center (DAC) 21 Nov 2000.

**C. OBJECTIVE.** The objective of the tests was to determine if the unitized Polish TNT fiberboard box on the 42" x 53" wood pallet met the Modified MIL-STD-1660 test requirements for Level "C" transportation and storage prior to the acceptance of the unitization procedures by the U.S. Army.

**D. CONCLUSION.** As a result of the performance of the unitized load, the unitized Polish TNT fiberboard box on a 42" x 53" wood pallet with the two (2) end gate design, can be used for Level "C" storage and transportation.

**PART 2 - ATTENDEES**

**DATE PERFORMED:**

Test Unit #1- 26 January 2004

Test Unit #2- 27 January 2004

Test Unit #3- 28 January 2004

Test Unit #4- 29 January 2004

Test Unit #5- 2 February 2004

Test Unit #6- 3 February 2004

**ATTENDEES**

Jeffery L. Dugan  
General Engineer  
DSN 956-8090  
(918) 420-8090

Daryl Sieczkowski  
Electronics Technician  
DSN 956-8988  
(918) 420-8988

**MAILING ADDRESS**

Director  
U.S. Army Defense Ammunition Center  
ATTN: SJMAC-DEV  
1 C Tree Road, Bldg. 35  
McAlester, OK 74501-9053

Director  
U.S. Army Defense Ammunition Center  
ATTN: SJMAC-DEV  
1 C Tree Road, Bldg. 35  
McAlester, OK 74501-9053

### **PART 3 - TEST PROCEDURES**

The test procedures outlined in this section were extracted from MIL-STD-1660, "Design Criteria for Ammunition Unit Loads," 8 April 1977, and modified for testing a unit load for Level "C" transportation and storage. This standard identifies steps that a unitized load must undergo if it is to be considered acceptable for Level "C". In short, Level "C" is defined as follows: a) Items are to be used or consumed at the first destination. b) Shock, vibration, and static loading will be encountered only during a limited transportation cycle. c) Items will be stored in a favorable warehouse environment for a temporary period of less than 6 months. d) Packing guards against the effects of expected environmental exposure during loading, unloading, or intransit delays. e) Packing is able to withstand stacking and superimposed loads during shipment and temporary storage. The five tests normally conducted on the test specimen are summarized below.

**A. STACKING TEST.** The specimen will be tested to simulate a stack of identical unit loads two (2) units high, for a period of one hour. This stacking load will be simulated by subjecting the unit load to a compression weight equal to an equivalent unit load on top of the bottom unit load. Photo 1 shows an example of a unit load in the compression tester.

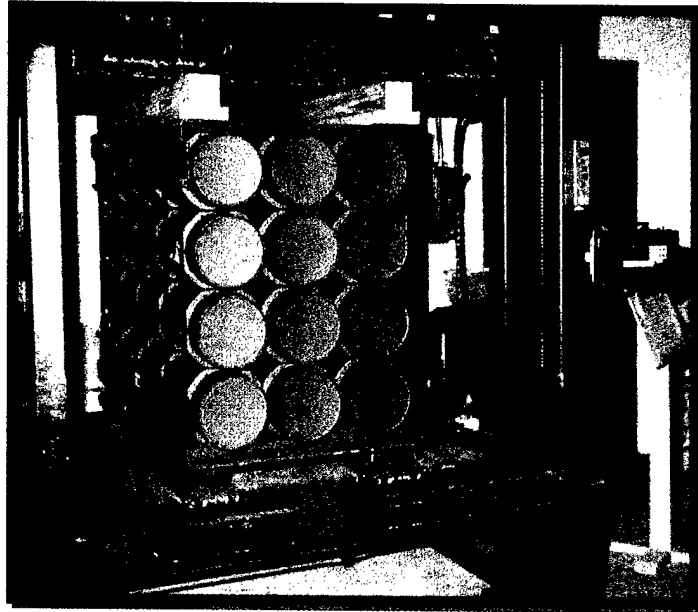

**Photo 1. Example of Compression Tester.**

**(2.75-inch Hydra 70, PA151 Rocket Pallet in the compression tester.)**

**B. REPETITIVE SHOCK TEST.** The repetitive shock test is conducted IAW Method 5019, Federal Standard 101. The test procedure is as follows: The test specimen will be placed on (not fastened to) the platform. With the load in one position, the platform will be vibrated at 1/2-inch amplitude (1-inch double amplitude) starting at a frequency of approximately 3 cycles-per-second. The frequency will be steadily increased until the package leaves the platform. The resonant frequency is achieved when a 1/16-inch-thick feeler gage momentarily slid freely between every point on the specimen in contact with the platform at some instance during the cycle. Midway into the testing period, the specimen will be rotated 90 degrees, and the test continued for the duration. Unless failure occurred, the total time of vibration will be one hour. Photo 2 shows an example of the repetitive shock test.

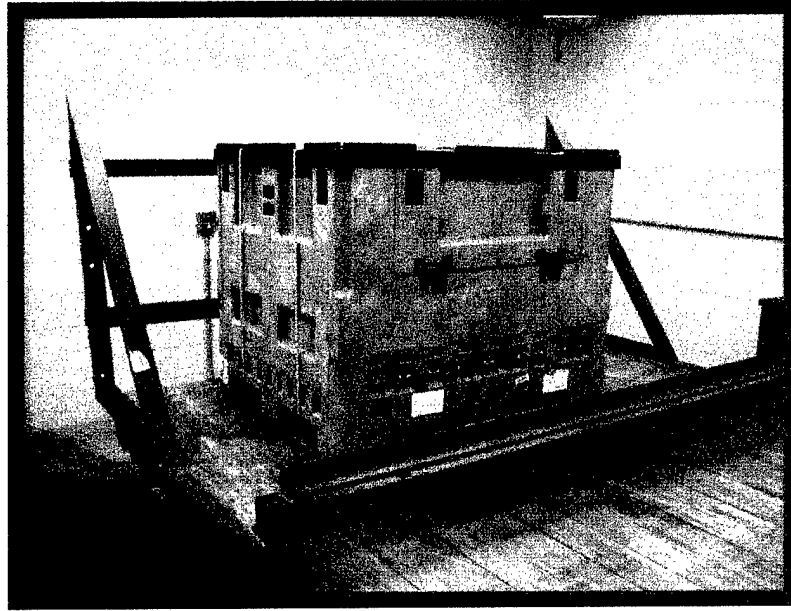
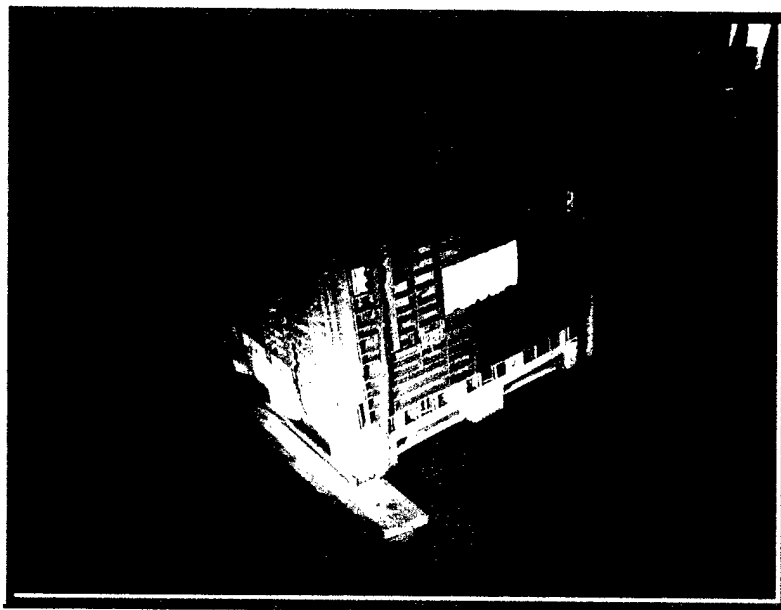

**Photo 2. Example of the Repetitive Shock Test.  
(Plastic Gemini Pallet Box)**

**C. EDGEWISE ROTATIONAL DROP TEST.** This test is conducted using the procedures of Method 5008, Federal Standard 101. The procedure for the edgewise rotational drop test is as follows: The specimen will be placed on its skids with one end of the pallet supported on a beam 6 inches high. The height of the beam will be increased as necessary to ensure that there is no support for the skids between the ends of the specimen when dropping takes place, but was not high enough to cause the specimen to slide on the supports when the dropped end is raised for the drop. The unsupported end of the specimen is then raised and allowed to fall freely to the concrete, pavement, or similar unyielding surface from a prescribed height. Unless otherwise specified, the height of drop for level C protection conforms to the following tabulation:

GROSS WEIGHT (WITHIN RANGE LIMITS) (Pounds)	HEIGHT OF DROPS ON EDGES Level C (Inches)
600 lbs and less	$L/2.7 + 6$ inches
601- 3,000 lbs	$L/8 + 6$ inches
3,001 lbs and greater	$L/16 + 6$ inches

\*Note - L is the longest length in inches of the pallet/skid edge.



**Photo 3. Example of Edgewise Rotational Drop Test  
(Plastic XYTEC 4845 Pallet Box)**

**D. FORKLIFTING TESTS.** The specimen shall be lifted clear of the ground by a forklift from the end of the specimen and transported on the forks in the level or back-tilt position across a hard pavement for a distance of not less than 100 feet. The forklift will pass over the forklift hazard course as outlined in MIL-STD-1660. The hazard course will consist of parallel pairs of 1-inch boards spaced 54 inches

apart and will be laid flatwise on the pavement across the path of the forklift. The first pair will be placed securely across the forklift's path and centered 30 feet from the starting point; the second pair will be laid 60 feet from the starting point at an angle of approximately 60 degrees to the path so the first wheel strikes first; and the third pair will be laid 90 feet from the starting point approximately 75 degrees to the path so the right wheel strikes first. The forklift will pass over the forklift hazard course 2 times in approximately 23 seconds, and then be brought to a stop. The load shall be observed for deflection and damage. The specimen will be rotated 90 degrees and the load lifted from the side and the above steps repeated.

**E. DISASSEMBLY TEST.** Following all rough handling tests the specimen may be squared up within 2 inches of its original shape and on a flat level surface. The strapping will then be cut and removed from the palletized load. Assembly of the load will be such that it retains its unity upon removal of the strapping.

## **PART 4 - TEST EQUIPMENT**

### **A. COMPRESSION TESTER.**

1. Nomenclature	Compression Table
2. Manufacturer:	Ormond Manufacturing
3. Platform:	60- by 60-inches
4. Compression Limit:	50,000 pounds
5. Tension Limit:	50,000 pounds

### **B. TRANSPORTATION (REPETITIVE SHOCK)SIMULATOR.**

1. Nomenclature	Repetitive Shock Simulator
2. Manufacturer:	Gaynes Laboratory
3. Capacity:	6,000-pound payload
4. Displacement:	1/2-inch amplitude
5. Speed:	50 to 400 RPM
5. Platform:	5- by 8-foot

### **C. INCLINED PLANE.**

1. Nomenclature	Incline Plane Impact Tester
2. Manufacturer:	Conbur Incline
3. Type:	Impact Tester
4. Grade:	10 percent incline
5. Length:	12-foot

## **PART 5 - TEST RESULTS**

**A. CONTAINER DATA.** The test units were inertly loaded to the specified design weight. Special care was taken to ensure that each individual interior ammunition container had the proper amount of weight in order to achieve a realistic pallet center of gravity (CG). Once properly prepared, the test unit was tested using modified MIL-STD-1660, "Design Criteria for Ammunition Unit Loads," requirements for Level "C" transportation and storage.

### **TEST UNIT #1:**

Test Date: 26 January 2004

Weight: 1,820 pounds

Length: 42 inches

Width: 53 inches

Height: 42-1/4 inches

### **Test Unit Configuration:**

See Test Sketch #1 in Part 6

### **TEST UNIT #2:**

Test Dates: 27 January 2004

Weight: 1,830 pounds

Length: 42 inches

Width: 53 inches

Height: 42-1/4 inches

### **Test Unit Configuration:**

Same as Test Sketch #1 with the tension net I removed and three 5/8" steel bands placed around the load.

### **TEST UNIT #3:**

Test Date: 28 January 2004

Weight: 1,820 pounds

Length: 42 inches

Width: 53 inches

Height: 42-1/4 inches

### **Test Unit Configuration:**

See Test Sketch #1 in Part 6.

**TEST UNIT #4:**

Test Dates: 29 January 2004  
Weight: 1,830 pounds  
Length: 42 inches  
Width: 53 inches  
Height: 42-1/4 inches

**Test Unit Configuration:**

Same as Test Sketch #1  
with the tension net I removed  
and three, 3/4" steel bands  
placed around load.

**TEST UNIT #5:**

Test Dates: 2 February 2004  
Weight: 1,825 pounds  
Length: 42 inches  
Width: 53 inches  
Height: 42-1/4 inches

**Test Unit Configuration:**

See Test Sketch #2 in Part 6.

**TEST UNIT #6:**

Test Dates: 3 February 2004  
Weight: 1,825 pounds  
Length: 42 inches  
Width: 53 inches  
Height: 42-1/4 inches

**Test Unit Configuration:**

See Test Sketch #2 in Part 6.

**B. TEST RESULTS - TEST UNIT #1:** Test Units #1 and #3 were wrapped in tensionet I in accordance with the Test Sketch #1 in Part 6. See Photo 4 for an example of Test Units #1 and #3.

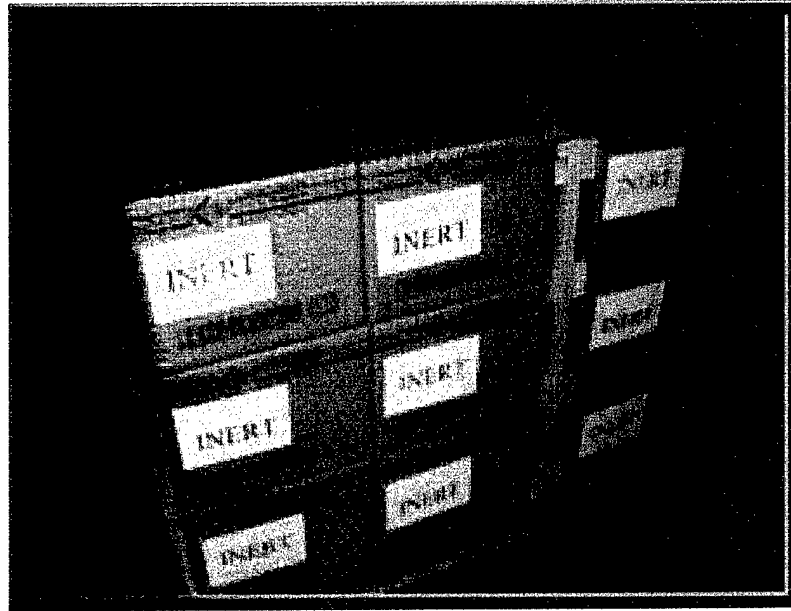

**Photo 4. Example of Test Units #1 and #3**

**1. COMPRESSION TEST.** Test Unit #1 was compressed with a load force of 1,820 pounds for 60 minutes on 26 January 2004. There was no damage noted to the test unit as a result of this test. See Photo 5 below for a typical picture of the test unit in the compression tester.

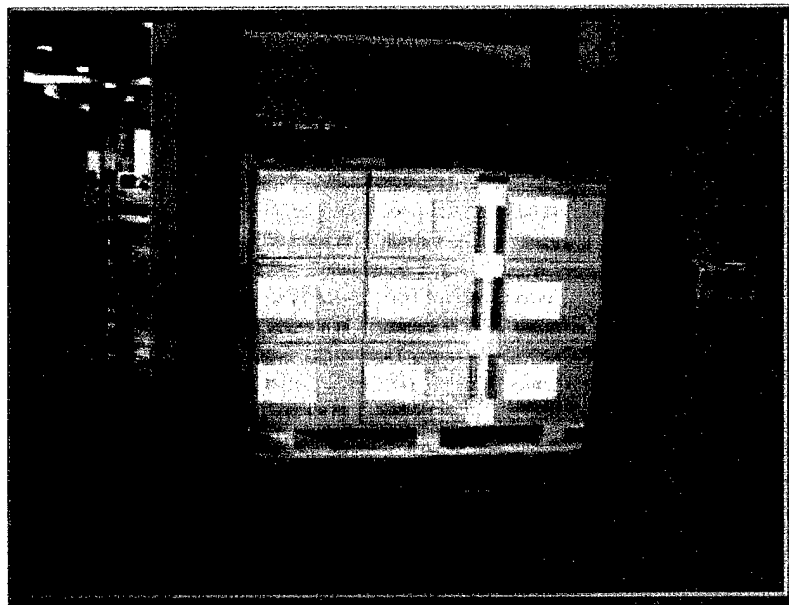

**Photo 5. Test Setup for Compression Testing.**

2. **REPETITIVE SHOCK TEST.** Test Unit #1 was vibrated 30 minutes at 190 RPM in the longitudinal orientation and 30 minutes at 180 RPM in the lateral orientation on 26 January 2004. There was 3" of movement of the entire load on the pallet and may be a cause for failure, however, the drop tests will be conducted. See Photo 6 for the test setup for the vibration test.

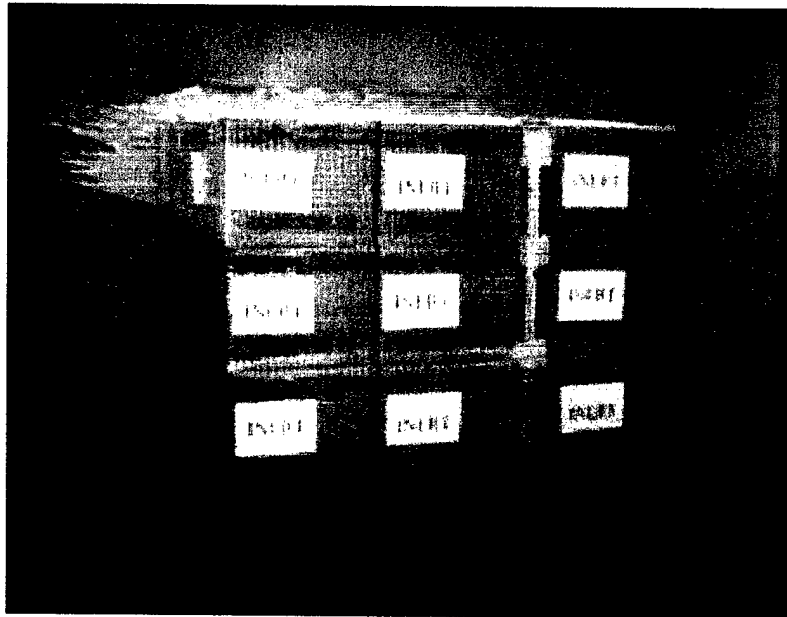

**Photo 6. Test Setup for Vibration Tests.**

3. **EDGEWISE ROTATIONAL DROP TEST.** Test Unit #1 was edgewise rotationally dropped from a height of 12-1/2 inches on both longitudinal sides and both lateral sides. The entire load shifted 6" and is considered a failure. Testing on this test unit ceased. See Photo 7 for the shifting of the load during drop testing. See Photo 8 for the test setup for the drop tests.



**Photo 7. Load Shifting During Drop Testing.**



**Photo 8. Test Setup for Drop Testing.**

4. **CONCLUSION.** Test Unit #1 failed during the drop testing.

C. **TEST RESULTS - TEST UNIT #3:** See Test Sketch #1 in Part 6 for test configuration.

1. **COMPRESSION TEST.** Test Unit #3 was compressed with a load force of 1,820 pounds for 60 minutes on 28 January 2004. There was no damage noted to the test unit as a result of this test.

2. **REPETITIVE SHOCK TEST.** Test Unit #3 was vibrated 30 minutes at 190 RPM in the longitudinal orientation and 30 minutes at 180 RPM in the lateral orientation on 28 January 2004. The entire load shifted 7" and was considered a failure. No additional testing was conducted on this test unit. See Photo 10 for the shifting of the load during vibration testing.

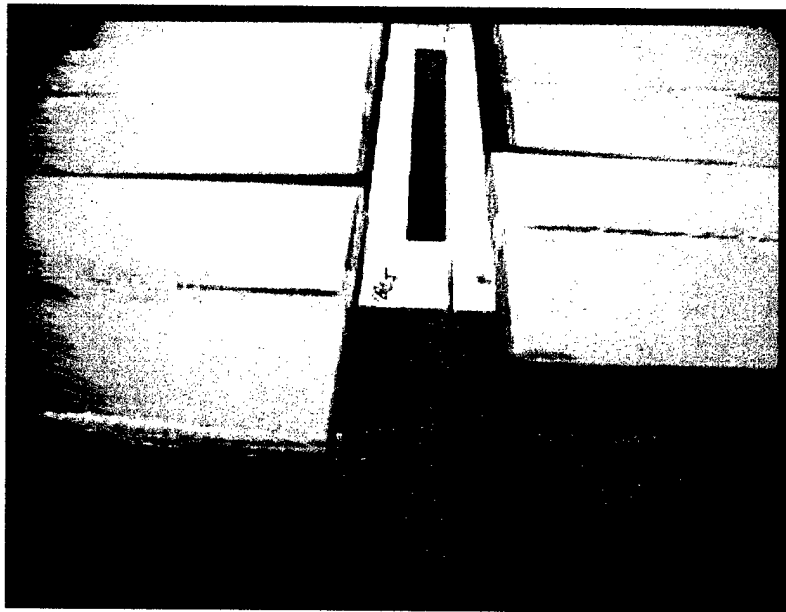

**Photo 10. Shifting of the Load During Vibration Testing**

3. **CONCLUSION.** Test Unit #3 failed during the vibration testing. The tensioner I does not appear suitable for this type of application.

**D. TEST RESULTS - TEST UNIT #2:** Test Units #2 and #4 were steel banded with a gate in the middle. See Photo 9 for an example of Test Units #2 and #4.



**Photo 9. Example of Test Units #2 and #4**

**1. COMPRESSION TEST.** Test Unit #2 was compressed with a load force of 1,830 pounds for 60 minutes on 27 January 2004. No damage was noted as a result of this test.

**2. REPETITIVE SHOCK TEST.** Test Unit #2 was vibrated 90 minutes at 225 RPM in the longitudinal orientation and 259 RPM in the lateral orientation. No damage was noted as a result of this test.

**3. EDGEWISE ROTATIONAL DROP TEST.** Test Unit #2 was edgewise rotationally dropped from a height of 12-1/2 inches on both longitudinal sides and both lateral sides. Minor shifting of 1" of the entire load was noted.

**4. FORKLIFTING TEST.** Test Unit #2 was lifted from the end of the pallet on the forks of the forklift truck and carried over the hazard course two times with

no damage or instability noted. The test unit was lifted from the opposite end of the pallet and the above steps accomplished with no problems encountered.

5. **DISASSEMBLY TEST**. During the disassembly of Test Unit #2 no additional problems were noted.

6. **CONCLUSION**. Test Unit #2 passed all required tests.

E. **TEST RESULTS - TEST UNIT #4:**

1. **COMPRESSION TEST**. Test Unit #4 was compressed with a load force of 1,830 pounds for 60 minutes on 29 January 2004. No damage was noted as a result of this test.

2. **REPETITIVE SHOCK TEST**. Test Unit #4 was vibrated 30 minutes at 190 RPM in the longitudinal orientation and 180 RPM in the lateral orientation. The entire load shifted 6" during the vibration testing and was considered a failure. Photo 11 depicts the shifting that occurred during the testing.

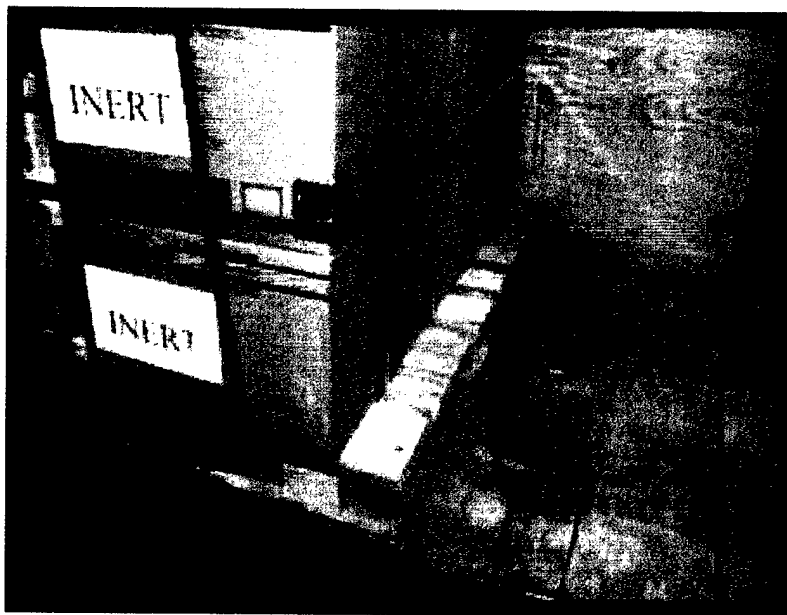
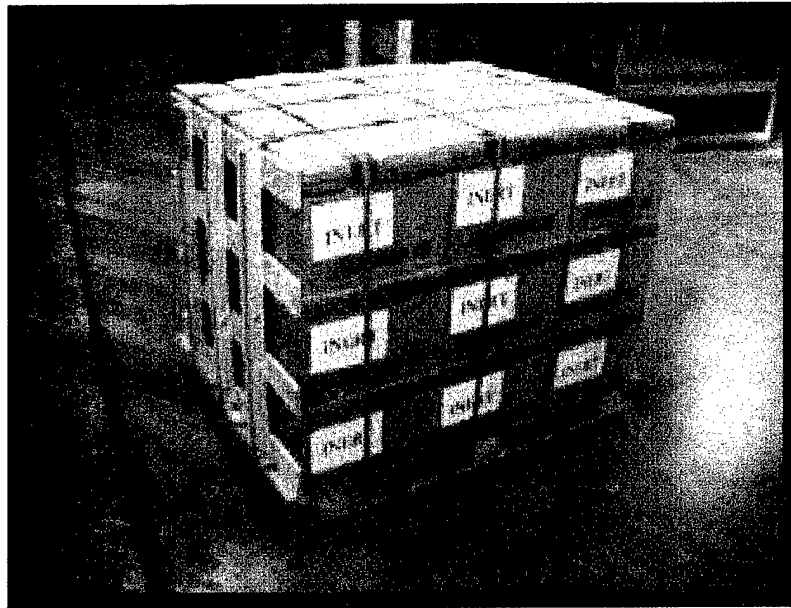

Photo 11. Shifting of the Load During Vibration Testing

3. **CONCLUSION.** Test Unit #4 failed during the vibration testing. There was insufficient restraint in the lateral position with this configuration, and it is not recommended for use.

F. **TEST RESULTS - TEST UNIT #5:** Test Units #5 and #6 were steel banded with an end gate on each end in accordance with Test Sketch #2 in Part 6. See Photo 12 for an example of Test Units #5 and #6.



**Photo 12. Example of Test Units #5 and #6**

1. **COMPRESSION TEST.** Test Unit #5 was compressed with a load force of 1,825 pounds for 60 minutes on 2 February 2004. No damage was noted as a result of this test. See Photo 13 for test setup.

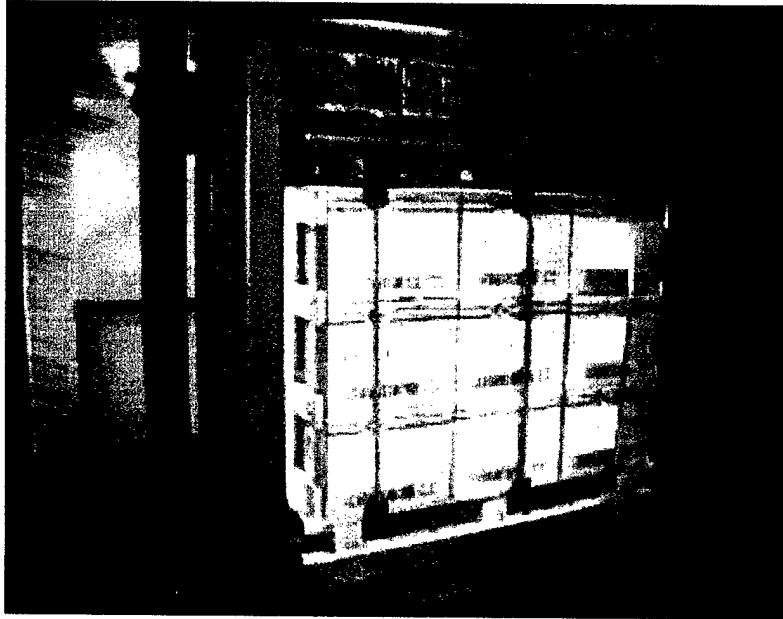

**Photo 13. Test Setup for Compression Testing.**

2. **REPETITIVE SHOCK TEST.** Test Unit #5 was vibrated 30 minutes at 190 RPM in the longitudinal orientation and 180 RPM in the lateral orientation. No damage was noted as a result of this test. See Photo 14 for test setup.

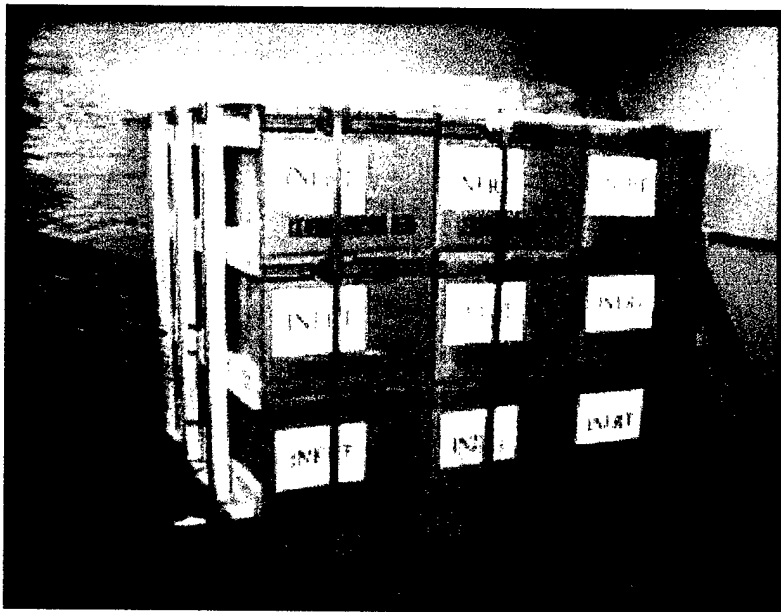

**Photo 14. Test Setup for Repetitive Shock Testing.**

**3. EDGEWISE ROTATIONAL DROP TEST.** Test Unit #5 was edgewise rotationally dropped from a height of 12-1/2 inches on both longitudinal sides and both lateral sides. No damage was noted as a result of the drop testing. See Photo 15 for test setup.



**Photo 15. Test Setup for Edgewise Rotational Drop Testing.**

**4. FORKLIFTING TEST.** Test Unit #5 was lifted from the end of the pallet on the forks of the forklift truck and carried over the hazard course two times with no damage or instability noted. The test unit was lifted from the opposite end of the pallet and the above steps accomplished with no problems encountered. See Photo 16 for test setup.



**Photo 16. Test Setup for Forklifting Testing.**

5. **DISASSEMBLY TEST.** During the disassembly of Test Unit #5 no additional problems were noted.

6. **CONCLUSION.** Test Unit #5 passed all required tests.

**G. TEST RESULTS - TEST UNIT #6:**

1. **COMPRESSION TEST.** Test Unit #6 was compressed with a load force of 1,825 pounds for 60 minutes on 3 February 2004. No damage was noted as a result of this test.

2. **REPETITIVE SHOCK TEST.** Test Unit #6 was vibrated 30 minutes at 190 RPM in the longitudinal orientation and 180 RPM in the lateral orientation. No damage was noted as a result of this test.

3. **EDGEWISE ROTATIONAL DROP TEST.** Test Unit #6 was edgewise rotationally dropped from a height of 12-1/2 inches on both longitudinal sides and both lateral sides. No damage was noted as a result of the drop testing.

4. **FORKLIFTING TEST.** Test Unit #6 was lifted from the end of the pallet on the forks of the forklift truck and carried over the hazard course two times with no damage or instability noted. The test unit was lifted from the opposite end of the pallet and the above steps accomplished with no problems encountered.

5. **DISASSEMBLY TEST.** During the disassembly of Test Unit #6 no additional problems were noted.

6. **CONCLUSION.** Test Unit #6 passed all required tests. Test Units #5 and #6 passed the modified MIL-STD-1660 test requirements with minimal damage to the fiberboard boxes. As a result of the performance of the unitized load, the unitized Polish TNT fiberboard box on a 42" x 53" wood pallet with the two (2) end-gate design, can be utilized for Level "C" storage and transportation.

## **PART 6- DRAWINGS**

The following test sketches represent the load configuration that was subjected to the test criteria.

Test Sketch #1, Test Units 1 and #3

# UNITIZATION PROCEDURES<sup>•</sup> FOR BULK EXPLOSIVES PACKED IN PAPERBOARD BOXES, SECURED WITH STRETCH NET, UNITIZED 36 BOXES PER 42" X 53" PALLET; APPROX BOX SIZE 16-3/16" L X 10-5/8" W X 12-1/4" H

• THE PROCEDURES AS DELINEATED IN THIS DRAWING ARE FOR INTERPLANT/DEPOT SHIPMENT ONLY.

**DISTRIBUTION STATEMENT A:**

APPROVED FOR PUBLIC RELEASE;  
DISTRIBUTION IS UNLIMITED.

## U.S. ARMY MATERIEL COMMAND DRAWING

APPROVED, U.S. ARMY FIELD SUPPORT COMMAND		<b>CAUTION: VERIFY PRIOR TO USE AT <a href="http://WWW.DAC.ARMY.MIL">WWW.DAC.ARMY.MIL</a> THAT THIS IS THE MOST CURRENT VERSION OF THIS DOCUMENT. THIS IS PAGE 1 OF 6.</b>			
AMSTA-AR-WEP-RR		<b>DO NOT SCALE</b>		<b>FEBRUARY 2004</b>	
AMSFS-ST		ENGINEER OR TECHNICIAN	BASIC REV.	LAURA A. FIEFFER	
APPROVED BY ORDER OF COMMANDING GENERAL, U.S. ARMY MATERIEL COMMAND		TRANSPORTATION ENGINEERING DIVISION			
U.S. ARMY DEFENSE AMMUNITION CENTER		VALIDATION ENGINEERING DIVISION		TESTED	
		ENGINEERING DIRECTORATE			
		CLASS	DIVISION	DRAWING	FILE
		19	48	4177/6	20PA1007

PROJECT CA 193/6-83

PALLET UNIT DATA				
ITEMS INCLUDED		HAZARD CLASS AND DIMSION	COMPAT-IBILTY GROUP	APPROX WEIGHT LBS
NSN	DODIC			
1376-				

HAZARD CLASSIFICATION DATA CONTAINED IN THE ABOVE CHART IS FOR GUIDANCE AND INFORMATIONAL PURPOSES ONLY. VERIFICATION OF THE SPECIFIED DATA SHOULD BE MADE BY CONSULTING THE MOST RECENT JOINT HAZARD CLASSIFICATION SYSTEM LISTING OR OTHER APPROVED LISTING(S).

(GENERAL NOTES CONTINUED)

- K. ALL FILLER ASSEMBLIES WILL BE POSITIONED IN THE TOP LAYER OR LAYERS OF THE CENTER STACK OF A UNIT LOAD.
- L. UNIT LOADS MUST ONLY BE MADE UP WITH FULL LAYERS. FOR REDUCED QUANTITIES IN A UNIT LOAD, HOWEVER, ONE OR TWO LAYERS MAY BE OMITTED, AND/OR A FULL LAYER MAY CONSIST OF FOUR BOXES AND EIGHT FILLER ASSEMBLIES. ONLY ONE UNIT LOAD HAVING A REDUCED QUANTITY OF ITEMS SHOULD BE PERMITTED PER LOT OF THAT ITEM. CARE SHOULD BE TAKEN TO INSURE THAT "REDUCED-QUANTITY" UNITS ARE EVENLY ALIGNED HORIZONTALLY AND VERTICALLY AS SPECIFIED IN GENERAL NOTE "C" AT RIGHT.
- M. CONVERSION TO METRIC EQUIVALENTS: DIMENSIONS WITHIN THIS DOCUMENT ARE EXPRESSED IN INCHES AND WEIGHTS ARE EXPRESSED IN POUNDS. WHEN NECESSARY, THE METRIC EQUIVALENT MAY BE COMPUTED ON THE BASIS OF ONE INCH EQUALS 25.4MM AND ONE POUND EQUALS 0.454 KG.
- N. THE MAJORITY OF THE STRETCH NET HAS BEEN OMITTED FROM THE "PALLET UNIT" DETAIL ON PAGE 4 FOR CLARITY PURPOSES.
- O. DIMENSIONAL LUMBER SPECIFIED IS OF A NOMINAL SIZE; I.E., 2" X 4" MATERIAL IS ACTUALLY 1-1/2" THICK BY 3-1/2" WIDE.
- P. CAUTION: PALLET UNITS MUST NOT BE STACKED MORE THAN TWO HIGH FOR STORAGE OR SHIPMENT.

GENERAL NOTES

- A. THIS DOCUMENT HAS BEEN PREPARED AND ISSUED IN ACCORDANCE WITH AR 740-1, AND AUGMENTS TM 743-200-1 (CHAPTER 5).
- B. DIMENSIONS, CUBE AND WEIGHT OF A PALLET UNIT WILL VARY SLIGHTLY DEPENDING UPON THE ACTUAL DIMENSIONS OF THE BOXES AND THE DENSITY OF THE SPECIFIC ITEM BEING UNITIZED.
- C. WHEN ASSEMBLING A PALLET UNIT, CARE SHALL BE TAKEN TO INSURE THAT BOXES AND FILLER ASSEMBLIES ARE EVENLY ALIGNED HORIZONTALLY AND VERTICALLY SO THAT THE SIDES AND ENDS OF THE PALLET DO NOT EXCEED A 1/2" TOLERANCE.
- D. UNIT LOAD MARKINGS WILL BE ACCOMPLISHED IN ACCORDANCE WITH DAC DRAWING ACV00581.
- E. THE STRETCH NET WILL BE APPLIED TO THE PALLET UNIT IN THE FOLLOWING MANNER WHEN UNITIZING THREE LAYERS OF BOXES:
  - 1. SIX COMPLETE WRAPS AROUND THE BOTTOM OF THE PALLET UNIT.
  - 2. FOUR COMPLETE WRAPS SPIRALING TO THE TOP OF THE PALLET UNIT.
  - 3. FOUR COMPLETE WRAPS AROUND THE TOP OF THE PALLET UNIT.
  - 4. FOUR COMPLETE WRAPS SPIRALING BACK TO THE BOTTOM OF THE PALLET UNIT WHERE THE END IS TIED.
- F. THE STRETCH NET WILL BE APPLIED TO THE PALLET UNIT IN THE FOLLOWING MANNER WHEN UNITIZING TWO LAYERS OF THE BOXES:
  - 1. FOUR COMPLETE WRAPS AROUND THE BOTTOM OF THE PALLET UNIT.
  - 2. ONE COMPLETE WRAP SPIRALING TO THE TOP OF THE PALLET UNIT.
  - 3. THREE COMPLETE WRAPS AROUND THE TOP OF THE PALLET UNIT.
  - 4. ONE COMPLETE WRAPS SPIRALING BACK TO THE BOTTOM OF THE PALLET UNIT WHERE THE END IS TIED.
- G. THE STRETCH NET WILL BE APPLIED TO THE PALLET UNIT IN THE FOLLOWING MANNER WHEN UNITIZING ONE LAYER OF BOXES.
  - FOUR COMPLETE WRAPS SPIRALING BACK TO THE BOTTOM OF THE PALLET UNIT WHERE THE END IS TIED.
- H. FOR THE PREFERRED METHOD OF INITIAL AND FINAL ATTACHMENT OF THE STRETCH NET TO THE PALLET UNIT, REFER TO THE STRETCH NET MANUFACTURER'S RECOMMENDATIONS. FOR PROPER/EVEN TENSIONING OF THE NETTING TO THE PALLET UNIT, THE STRETCH NETTING SHALL ONLY BE APPLIED USING A STRETCH-NET MACHINE FOR APPLICATION OF THE SPECIFIED NUMBER OF WRAPS.
- J. IF LESS THAN 36 BOXES ARE TO BE LOADED ON A PALLET, IT SHALL BE ACCOMPLISHED BY SUBSTITUTING FILLER ASSEMBLIES, AS DEPICTED ON PAGE 5, FOR THE OMITTED BOXES. IF MORE THAN 12 BOXES ARE TO BE OMITTED FROM THE PALLET UNIT, IT CAN BE ACCOMPLISHED BY USING A COMBINATION OF OMITTING A COMPLETE LAYER OF BOXES AND SUBSTITUTING FILLER ASSEMBLIES AS NECESSARY, TO SATISFY THE REDUCED QUANTITY OF BOXES TO BE UNITIZED.

(CONTINUED AT LEFT)

DRAFT

MATERIAL SPECIFICATIONS

- LUMBER - - - - - : SEE TM 743-200-1 (DUNNAGE LUMBER) AND VOLUNTARY PRODUCT STANDARD PS 20.
- NAILS - - - - - : ASTM F1667; COMMON STEEL NAIL (NLCMS OR NLCHMS). ALT: UNDERLAYMENT NAIL (NLUL), PALLET NAIL (NLPL), OR COOLER NAIL (NLCL) OF SAME SIZE.
- PALLET - - - - - : MIL SPEC MIL-P-15011; 4-WAY ENTRY, STYLE 1B, TYPE I, CLASS 1, PRESERVATIVE AND HEAT TREATED.
- STRETCH NET - - - - - : TENSIONET I, PRODUCT ON-0580, CONWED CORP. (OR EQUAL).

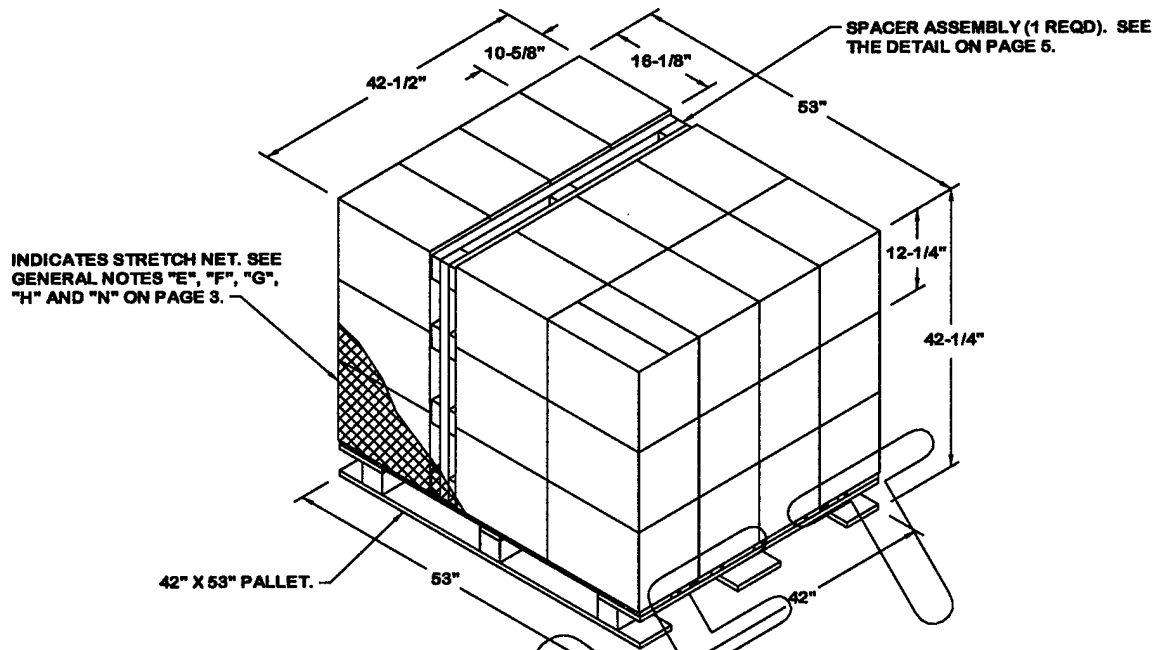

**PALLET UNIT**

SEE GENERAL NOTE "B" ON PAGE 3.

36 BOXES OF TNT @ 47 LBS	-----	1,692 LBS (APPROX)
DUNNAGE	-----	42 LBS
PALLET	-----	90 LBS
<hr/>		
TOTAL WEIGHT	-----	1,824 LBS (APPROX)
CUBE	-----	55.1 CU FT (APPROX)

**BILL OF MATERIAL**

LUMBER	LINEAR FEET	BOARD FEET
2" X 4"	30	20
NAILS	NO. REQD	POUNDS
10d (3")	48	3/4
PALLET, 42" X 53" ----- 1 REQD -----		90 LBS
STRETCH NET, 3/4" ----- 350' REQD -----		0.98 LBS

HORIZONTAL PIECE, 2" X 4" X 42" (6 REQD). NAIL TO THE VERTICAL PIECES W/2-10d NAILS AT EACH JOINT.

VERTICAL PIECE, 2" X 4" X 36" (3 REQD).

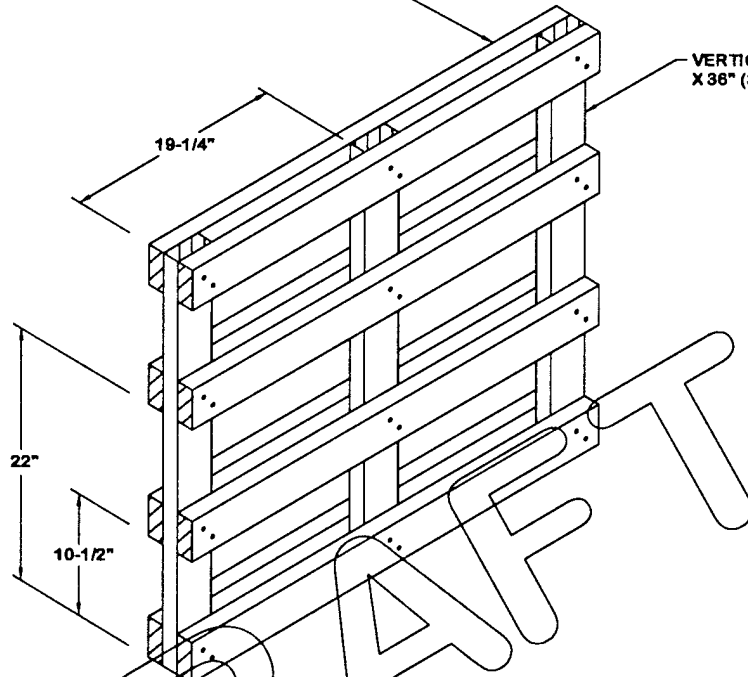

**SPACER ASSEMBLY**

**CAUTION:** FIELD CHECK DIMENSIONS PRIOR TO CONSTRUCTION. THE MIDDLE FOUR HORIZONTAL PIECES MUST ALIGN WITH THE JOINTS BETWEEN THE BOXES. THE OVERALL DIMENSIONS OF THE ASSEMBLY MUST BE SUCH THAT IT IS EQUAL TO OR SLIGHTLY SMALLER THAN THE LENGTH (42-1/2" REF) AND HEIGHT (36-3/4" REF) OF THE STACKED BOXES. ADJUST THE DIMENSIONS AS NECESSARY TO COMPLY WITH THESE REQUIREMENTS.

# APPENDIX 141B

## UNITIZATION PROCEDURES FOR BOXED AMMUNITION AND COMPONENTS ON 4-WAY ENTRY PALLET

**BULK EXPLOSIVES, PACKED IN PAPERBOARD  
BOXES, UNITIZED 36 BOXES PER 42" X 53"  
PALLET; APPROX BOX SIZE 16-3/16" L X  
10-5/8" W X 12-1/4" H**

**NOTICE: THIS APPENDIX CANNOT STAND ALONE BUT MUST BE USED IN CONJUNCTION WITH  
THE BASIC UNITIZATION PROCEDURES DRAWING 19-48-4116-20PA1002.**

**DISTRIBUTION STATEMENT A:**

**APPROVED FOR PUBLIC RELEASE;  
DISTRIBUTION IS UNLIMITED.**

### U.S. ARMY MATERIEL COMMAND DRAWING

APPROVED, U.S. ARMY FIELD SUPPORT COMMAND		<b>CAUTION: VERIFY PRIOR TO USE AT WWW.DAC.ARMY.MIL THAT THIS IS THE MOST CURRENT VERSION OF THIS DOCUMENT. THIS IS PAGE 1 OF 4.</b>					
AMSTA-AR-WEP-RP		<b>DO NOT SCALE</b>		<b>FEBRUARY 2004</b>			
AMSFS-ST		ENGINEER OR TECHNICIAN	BASIC REV.	LAURA A. FIEFFER			
APPROVED BY ORDER OF COMMANDING GENERAL, U.S. ARMY MATERIEL COMMAND		TRANSPORTATION ENGINEERING DIVISION		SEE THE REVISION LISTING ON PAGE 2			
U.S. ARMY DEFENSE AMMUNITION CENTER		VALIDATION ENGINEERING DIVISION	TESTED	CLASS	DIVISION	DRAWING	FILE
		ENGINEERING DIRECTORATE		19	48	4116/ 141B	20PA1002

PALLET UNIT DATA				
ITEMS INCLUDED		● HAZARD CLASS AND DIVISION	● COMPATIBILITY GROUP	APPROX WEIGHT LBS
NSN	DODIC			
1376- XX-XXX-XXXX	ML51	1. 1	D	1, 854

● HAZARD CLASSIFICATION DATA CONTAINED IN THE ABOVE CHART IS FOR GUIDANCE AND INFORMATIONAL PURPOSES ONLY. VERIFICATION OF THE SPECIFIED DATA SHOULD BE MADE BY CONSULTING THE MOST RECENT JOINT HAZARD CLASSIFICATION SYSTEM LISTING OR OTHER APPROVED LISTING(S).

DRAFT

**GENERAL NOTES**

- A. THIS APPENDIX CANNOT STAND ALONE BUT MUST BE USED IN CONJUNCTION WITH THE BASIC INITIALIZATION PROCEDURES DRAWING 19-48-4116-20PA1002. TO PRODUCE AN APPROVED UNIT LOAD, ALL PERTINENT PROCEDURES, SPECIFICATIONS AND CRITERIA SET FORTH WITHIN THE BASIC DRAWING WILL APPLY TO THE PROCEDURES DELINEATED IN THIS APPENDIX. ANY EXCEPTIONS TO THE BASIC PROCEDURES ARE SPECIFIED IN THIS APPENDIX.
- B. DIMENSIONS, CUBE AND WEIGHT OF A PALLET UNIT WILL VARY SLIGHTLY DEPENDING UPON THE ACTUAL DIMENSIONS OF THE BOXES AND THE WEIGHT OF THE SPECIFIC ITEM BEING INITIALIZED.
- C. THE TWO OUTER LOAD STRAPS MUST BE THREADED THROUGH THE STRAP SLOTS OF A PALLET. THE MIDDLE LOAD STRAP WILL BE PRE-POSITIONED ON THE PALLET DECK PRIOR TO PLACING THE BOXES ON THE PALLET. LOAD STRAPS MUST BE TENSIONED AND SEALED PRIOR TO APPLICATION OF TIEDOWN STRAPS.
- D. INSTALL EACH TIEDOWN STRAP TO PASS UNDER THE TOP DECK BOARDS OF THE PALLET AND TO BE LOCATED AS SHOWN. TIEDOWN STRAPS WILL NOT BE APPLIED UNTIL THE LOAD STRAPS HAVE BEEN TENSIONED AND SEALED.
- E. THE FOLLOWING AMC DRAWINGS ARE APPLICABLE FOR OUTLOADING AND STORAGE OF THE ITEMS COVERED BY THIS APPENDIX.
  - CARLOADING - - - - - 19-48-4115-5PA1002
  - TRUCKLOADING - - - - 19-48-4117-11PA1003
  - STORAGE - - - - - 19-48-4118-1-2-3-4-14-22PA1002
  - END OPENING ISO CONTAINER - - - - - 19-48-4153-15PA1002
  - MILVAN - - - - - 19-48-4166-15PA1003
  - SIDE OPENING ISO CONTAINER - - - - - 19-48-4267-15PA1009
- F. IF ITEMS COVERED HEREIN ARE INITIALIZED PRIOR TO ISSUANCE OF THIS APPENDIX, THE BOXES NEED NOT BE REINITIALIZED SOLELY TO CONFORM TO THIS APPENDIX.
- G. THE INITIALIZATION PROCEDURES DEPICTED HEREIN MAY ALSO BE USED FOR INITIALIZING BULK EXPLOSIVES WHEN IDENTIFIED BY DIFFERENT NATIONAL STOCK NUMBERS (NSN) THAN WHAT IS SHOWN ON PAGE 2, PROVIDED THE BOX PACK DOES NOT VARY FROM WHAT IS DELINEATED HEREIN. THE EXPLOSIVE CLASSIFICATION OF OTHER ITEMS MAY BE DIFFERENT THAN WHAT IS SHOWN.
- H. THE STYLE 1B PALLET DELINEATED IN THE DETAIL AT LEFT NEED NOT HAVE CHAMFERS AS SPECIFIED WITHIN MILITARY SPECIFICATION MIL-P-15011 WHEN USED FOR THE INITIALIZATION OF ITEMS COVERED BY THIS APPENDIX.
- J. ALL DUNNAGE SHALL BE PRESERVATIVE TREATED IN ACCORDANCE WITH GENERAL NOTE "AA" IN THE BASIC PROCEDURES.
- K. FOR DETAILS OF THE PAPERBOARD BOX SEE DRAWING XXXXXX.

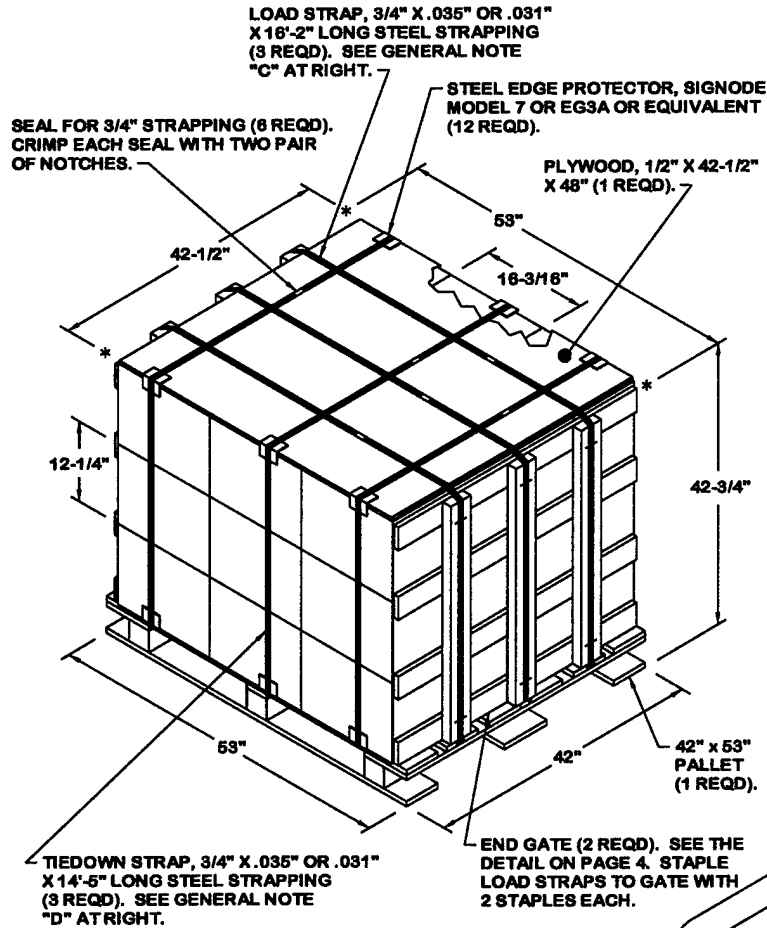

**PALLET UNIT**

SEE GENERAL NOTE "B" AT RIGHT.

36 BOXES OF TNT @ 47 LBS	-----	1,692 LBS (APPROX)
DUNNAGE	-----	72 LBS
PALLET	-----	90 LBS
<b>TOTAL WEIGHT</b>	-----	<b>1,854 LBS (APPROX)</b>
<b>CURE</b>	-----	<b>55.7 CU FT (APPROX)</b>

TOTAL WEIGHT ----- 1,854 LBS (APPROX)  
 CURE ----- 55.7 CU FT (APPROX)

**BILL OF MATERIAL**

LUMBER	LINEAR FEET	BOARD FEET
1" X 4"	28.00	9.33
2" X 4"	18.00	12.00
NAILS	NO. REQD	POUNDS
6d (2")	48	0.28
PALLET, 42" X 53" - - - - -	1 REQD - - - - -	90 LBS
STEEL STRAPPING, 3/4" - - - - -	91.75' REQD - - - - -	8.19 LBS
SEAL FOR 3/4" STRAPPING - - - - -	6 REQD - - - - -	NIL
PLYWOOD, 1/2" - - - - -	14.17 SQ FT REQD - - - - -	19.48 LBS
EDGE PROTECTORS - - - - -	12 REQD - - - - -	1.00 LBS
STAPLES, 15/16" X 3/4" - - - - -	12 REQD - - - - -	NIL

HORIZONTAL PIECE, 1" X 4" X 42" (4 REQD). NAIL TO THE VERTICAL PIECES W/2-8d NAILS AT EACH JOINT.

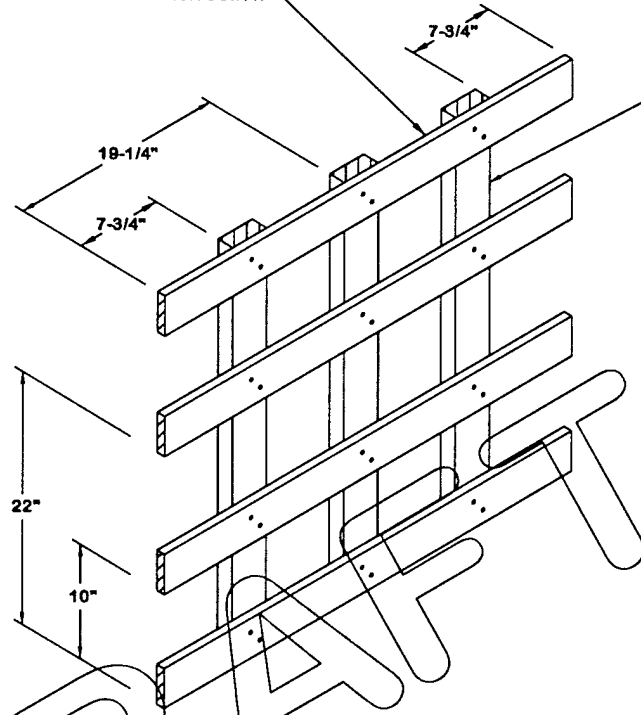

VERTICAL PIECE, 2" X 4" X 36" (3 REQD).

**END GATE**

CAUTION: FIELD CHECK DIMENSIONS PRIOR TO CONSTRUCTION. THE MIDDLE TWO HORIZONTAL PIECES MUST ALIGN WITH THE JOINTS BETWEEN THE BOXES. THE OVERALL DIMENSIONS OF THE ASSEMBLY MUST BE SUCH THAT IT IS EQUAL TO OR SLIGHTLY SMALLER THAN THE LENGTH (42-1/2" REF) AND HEIGHT (36-3/4" REF) OF THE STACKED BOXES. ADJUST THE DIMENSIONS AS NECESSARY TO COMPLY WITH THESE REQUIREMENTS.

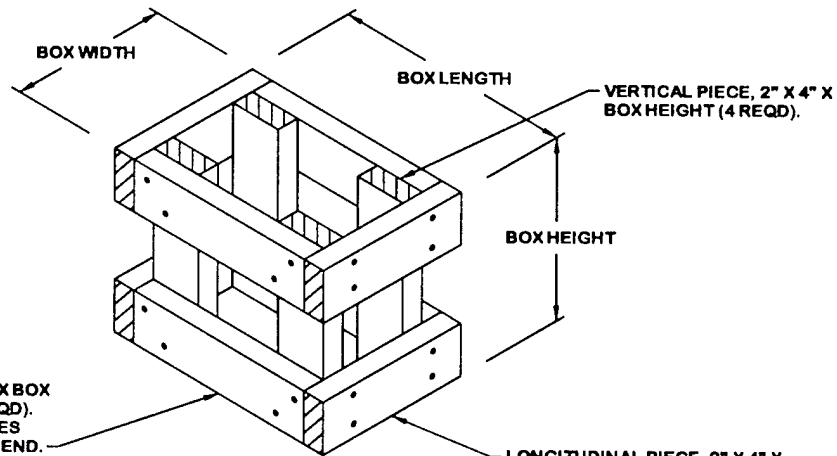

LATERAL PIECE, 2" X 4" X BOX LENGTH MINUS 3" (4 REQD). NAIL TO VERTICAL PIECES W/2-10d NAILS AT EACH END.

LONGITUDINAL PIECE, 2" X 4" X BOX WIDTH (4 REQD). NAIL TO VERTICAL PIECES W/2-10d NAILS AT EACH JOINT.

**FILLER ASSEMBLY**  
(FOR MINUS ONE BOX)