

AFRL-IF-RS-TR-2004-50
Final Technical Report
March 2004



PORTABLE DATA WALL TRANSITION TO PRODUCTION

CACI Technologies, Incorporated

APPROVED FOR PUBLIC RELEASE; DISTRIBUTION UNLIMITED.

**AIR FORCE RESEARCH LABORATORY
INFORMATION DIRECTORATE
ROME RESEARCH SITE
ROME, NEW YORK**

STINFO FINAL REPORT

This report has been reviewed by the Air Force Research Laboratory, Information Directorate, Public Affairs Office (IFOIPA) and is releasable to the National Technical Information Service (NTIS). At NTIS it will be releasable to the general public, including foreign nations.

AFRL-IF-RS-TR-2004-50 has been reviewed and is approved for publication

APPROVED: /s/

ROBERT M. FLO
Project Engineer

FOR THE DIRECTOR: /s/

JAMES W. CUSACK, Chief
Information Systems Division
Information Directorate

REPORT DOCUMENTATION PAGE

Form Approved
OMB No. 074-0188

Public reporting burden for this collection of information is estimated to average 1 hour per response, including the time for reviewing instructions, searching existing data sources, gathering and maintaining the data needed, and completing and reviewing this collection of information. Send comments regarding this burden estimate or any other aspect of this collection of information, including suggestions for reducing this burden to Washington Headquarters Services, Directorate for Information Operations and Reports, 1215 Jefferson Davis Highway, Suite 1204, Arlington, VA 22202-4302, and to the Office of Management and Budget, Paperwork Reduction Project (0704-0188), Washington, DC 20503

1. AGENCY USE ONLY (Leave blank)		2. REPORT DATE MARCH 2004	3. REPORT TYPE AND DATES COVERED Final Apr 01 – Aug 02	
4. TITLE AND SUBTITLE PORTABLE DATA WALL TRANSITION TO PRODUCTION			5. FUNDING NUMBERS C - F30602-00-D-0221/Task 0004 PE - 62702F PR - 459S TA - QF WU - 04	
6. AUTHOR(S) John D. Nolander, Annette L. McCoy and Timothy J Choate				
7. PERFORMING ORGANIZATION NAME(S) AND ADDRESS(ES) CACI Technologies 14151 Park Meadow Drive Chantilly Virginia 20151			8. PERFORMING ORGANIZATION REPORT NUMBER N/A	
9. SPONSORING / MONITORING AGENCY NAME(S) AND ADDRESS(ES) Air Force Research Laboratory/IFSB 525 Brooks Road Rome New York 13441-4505			10. SPONSORING / MONITORING AGENCY REPORT NUMBER AFRL-IF-RS-TR-2004-50	
11. SUPPLEMENTARY NOTES AFRL Project Engineer: Robert M. Flo/IFSB/(315) 330-2334/ Robert.Flo@rl.af.mil				
12a. DISTRIBUTION / AVAILABILITY STATEMENT APPROVED FOR PUBLIC RELEASE; DISTRIBUTION UNLIMITED.				12b. DISTRIBUTION CODE
13. ABSTRACT (Maximum 200 Words) This report details the contractor's ability to develop an interactive data wall (IDW) product line that would effectively transition IDW technology, developed in-house at Air Force Research Laboratories (AFRL) - Rome Research Site (RRS), from its current prototype status to a full-up production capability, making it commercially available to potential customers, both military and commercial. The scope of this effort was to demonstrate the contractor's capabilities to reproduce the portable, interactive data wall (PIDW) and its associated technologies. The completion of this objective would result in the delivery of a fully constructed and tested PIDW to AFRL/RRS as well as much needed PIDW documentation including: 1) a set of Assembly and Production Plans detailing the PIDW components, frame production, unit assembly, features, shipping specifications, schedule, and representative vendors and sources; and 2) a User's Manual which would provide instructions for frame assembly and equipment installation, raising and lowering the PIDW screen, projector maintenance and adjustment, and disassembly of the PIDW.				
14. SUBJECT TERMS Display Technology, Visualization Technology, Interactive Displays, Large Screen Displays, Human-Computer Interaction, Data Wall			15. NUMBER OF PAGES 69	
			16. PRICE CODE	
17. SECURITY CLASSIFICATION OF REPORT UNCLASSIFIED	18. SECURITY CLASSIFICATION OF THIS PAGE UNCLASSIFIED	19. SECURITY CLASSIFICATION OF ABSTRACT UNCLASSIFIED	20. LIMITATION OF ABSTRACT UL	

TABLE OF CONTENTS

<u>SECTION</u>	<u>TITLE</u>	<u>PAGE NO.</u>
1.0	INTRODUCTION	1
2.0	BACKGROUND	1
3.0	OBJECTIVE	1
4.0	TRANSITION TO PRODUCTION	2
4.1	PIDW Production	2
4.1.1	Co-Construction	2
4.1.2	Government Furnished Equipment and Engineering Drawings	2
4.1.3	Frame Vendor Selection and Manufacture	2
4.1.4	Integration of the PIDW	3
4.2	Assembly Plan	3
4.3	Production Plan	4
4.4	User's Manual Supplements	4
5.0	RESULTS	4
6.0	CONCLUSION	4
APPENDIX A - GFE		5
APPENDIX B - VOEKLER DRAWINGS		9
APPENDIX C - ASSEMBLY PLAN		12
APPENDIX D - PRODUCTION PLAN		48
APPENDIX E - USER MANUAL SUPPLEMENTS		61

TABLE OF FIGURES

Figure B-1 - Left Cart..... 9
Figure B-2 - Middle Cart..... 10
Figure B-3 - Fully-Assembled Cart 11
Figure 9.1.2-1. Cable Connections..... 24
Figure 2.0-1. Fully-Assembled PIDW--Front View 49
Figure 2.0-2. Fully-Assembled PIDW--Side View..... 49

TABLE OF TABLES

TABLE 3.0-1: REQUIRED HARDWARE..... 13

1.0 INTRODUCTION

The need to display and manipulate real-time multimedia data in a battlefield operations control center is critical to the Joint Commander directing air, land, naval, and space assets. **Interactive Data Walls (IDWs)** are a strong contender for solving the information management problems facing the 21st century military commander. IDWs use **Commercial Off-The-Shelf (COTS)** technology combined with specialized hardware and software to provide a unique capability for multimedia data display and control. They provide a high-resolution large screen display and wireless **Human-Computer Interaction (HCI)** capabilities which allow massive amounts of information available to the warfighters to be displayed to large groups of decision-makers simultaneously. The information is presented in a manner to support timely decision-making and alert the commanders as situations change. Data walls enable people at different locations to view a common picture and interact as if in the same location. Decision-quality information presented with data walls significantly improves the warrior's situational awareness leading to decisive military actions. The purpose of this effort was to develop an interactive data wall product line that would effectively transition data wall technology that has been developed in-house at **Air Force Research Laboratories (AFRL)** to potential customers, both military and commercial.

2.0 BACKGROUND

The **Advanced Displays and Intelligent Interfaces (ADII)** technology team of the Information Directorate of the Air Force Research Laboratory (AFRL/IF) in Rome, New York has successfully implemented a number of interactive data walls. In-house development includes wall-mounted interactive data walls, **deployable interactive data walls (DIDWs)**, and **portable interactive data walls (PIDWs)** each consisting of three horizontally tiled video projectors. **SYTRONICS, Inc.** constructed a PIDW based on the existing AFRL/IFSB PIDW design. The PIDW was designed to be disassembled, transported, and reassembled in a short period of time. Unlike the DIDW, this portable version is intended for indoor use and to be easily transported. While the DIDW requires a forklift and flatbed truck to transport it, the PIDW is designed so that it can be easily rolled into a location by two people. It is PC-based and designed to fit through a conventional three-foot doorway. Its footprint is 9¼'W x 5'H x 2¼'D while folded, and 9¼'W x 6¼'H x 4½'D extended. It is also a 1 x 3 LCD projector configuration. Each high-resolution projector displays 1280 x 1024 pixels for a total display resolution of 3840 x 1024 across a screen area 9' x 2¼'.

3.0 OBJECTIVE

The scope of this effort was to demonstrate **SYTRONICS'** capabilities to produce the PIDW and its associated technologies. Following the completion of the PIDW, **SYTRONICS** would become the turnkey provider to both military and commercial customers. Additionally, customer identified enhancements would be developed by **SYTRONICS**. The completion of this objective would result in the delivery of a fully constructed and tested PIDW to **Rome Research Site (RRS)**, Rome, New York; a set of Assembly and Production Plans detailing the PIDW components, frame production, unit assembly, features, shipping specifications, schedule, and representative

vendors and sources. Additionally, User's Manual Supplements would be developed which provide instructions for frame assembly and equipment installation, raising and lowering the PIDW screen, projector maintenance and adjustment, and disassembly of the PIDW.

4.0 TRANSITION TO PRODUCTION

Efforts for the PIDW transition to production included the following accomplishments.

- PIDW Production
- Assembly Plan
- Production Plan
- User's Manual Supplements

Detailed information regarding these efforts follow.

4.1 PIDW Production

4.1.1 Co-Construction

SYTRONICS personnel traveled to Rome Research Labs to participate in the co-production of a PIDW. The objectives were to become familiar with the assembly process and the alignment and calibration procedures; obtain additional video and digital photographs of the assembly, accomplish technical discussions, gather AFRL/IFSB PIDW requirements, and review the design, construction, operation, and use of the PIDW. The trip was highly successful and very productive. Valuable information was obtained for use in the construction of the data wall and preparation of the deliverables.

4.1.2 Government Furnished Equipment and Engineering Drawings

The Government provided some engineering drawings for the three-piece PIDW frame for purposes of obtaining quotes from local vendors to manufacture the frame.

The Government provided all components required for the assembly of the PIDW with the exception of the frame and the electrical supplies for the power assemblies. A list of GFE received by ***SYTRONICS*** is attached in Appendix A.

4.1.3 Frame Vendor Selection and Manufacture

Seven vendors were identified and evaluated as subcontractors to manufacture the frame. The engineering drawings were distributed to three of the vendors for quotes. All of the quotes were substantially higher than anticipated and became a critical area of concern for the producibility of the PIDW.

SYTRONICS extensively researched the cost issue to determine the manufacturing cost-drivers. The vendors identified the extensive riveting needed in the manufacture as the most significant cost driver. The next most significant cost driver identified by the vendors involved

the manufacturing tolerances of + or - .005.

SYTRONICS investigated welding the cabinet as opposed to riveting as a cost-effective alternative for manufacturing the cabinet. Following discussions with the Government and CACI, it was agreed that welding would be a high-risk approach due to the required tolerances.

At the Government's request, **SYTRONICS** investigated using T-slotted aluminum extrusion, an 80/20 Inc. product, as a potential cost-effective material for manufacturing the frame. **SYTRONICS** contacted Voelker Controls Company, a local distributor of 80/20 materials. Voelker Controls prepared Autocad drawings duplicating the form, fit, and function of the original IFSB three-piece PIDW design using 80/20 materials. Following extensive discussions, the Government approved the PIDW frame design using the 80/20 material. Voelker Controls was subcontracted to manufacture the frame in accordance with the Autocad drawings. Pictures of the drawings are attached in Appendix B.

4.1.4 Integration of the PIDW

Upon receiving the frame from Voelker Controls Company, **SYTRONICS** began the integration of all components into a PIDW configuration based on the existing AFRL/IFSB design. The frame design required some minor adjustments during the assembly process. The power strips were assembled and installed, all equipment was installed, and calibration and alignment was performed. No major problems were encountered during the assembly process. **SYTRONICS** performed an in-house acceptance test. **SYTRONICS** hosted Government personnel who performed the successful Government acceptance test.

4.2 Assembly Plan

An Assembly Plan detailing the step-by-step process required to assemble a PIDW was prepared. The Assembly Plan includes information and instruction on accomplishing the following.

- Acquiring the frame
- Acquiring required hardware
- Acquiring and installing required software
- Installing electrical apparatus
- Assembling the PIDW frame
- Installing the projection screen frame
- Installing hardware
- Performing set-up procedures
- Performing calibration and Alignment procedures

The Assembly Plan, in its entirety, is attached as Appendix C.

NOTE: The Assembly plan was prepared before the Government's decision to manufacture the frame with 80/20 extrusion. All references to the frame are based on the original riveted frame design. Due to funding constraints, the government elected not to update the Assembly Plan with the new frame design.

4.3 Production Plan

A document detailing information regarding the production of the PIDW was prepared. The Production Plan provides details for the following.

- All required hardware including model numbers
- Frame production
- Shipping specifications
- PIDW features
- Schedules
- Representative vendors and sources

The Production Plan, in its entirety, is attached as Appendix D.

4.4 User's Manual Supplements

AFRL/IFSB had prepared a User's Manual based on the original IFSB PIDW design. **SYTRONICS, Inc.** has provided supplements to that document to represent the 80/20 design. The supplements include the following.

- Frame Assembly and Equipment Installation
- Raising and Lowering the Screen of the PIDW
- Projector Maintenance and Adjustment on PIDW
- Disassembly of PIDW

The supplements are attached as Appendix E.

5.0 RESULTS

Government Acceptance Testing was successfully accomplished on 13 June 2002. Testing included equipment operation and functionality, projected image appearance and alignment, laser tracking, and voice recognition. All tests performed to Government satisfaction with **SYTRONICS** demonstrating its capability to successfully produce the PIDW.

6.0 CONCLUSION

SYTRONICS successfully demonstrated its ability to produce the PIDW. **SYTRONICS** continues to support the demonstration of the PIDW and marketing strategies related to transitioning data wall technology to potential customers. **SYTRONICS** has demonstrated the PIDW to potential customers at the *Interservice/Industry Training, Simulation and Education Conference (IITSEC)* 2001, and the *National Aerospace Systems and Technology Conference (NASTC)* 2002. Additionally, several potential customers have received PIDW demonstrations at **SYTRONICS'** facilities. Following firm orders, **SYTRONICS** will produce the PIDW as well as develop customer unique enhancements.

APPENDIX A - GFE

Inven- tory Tag Number	P/N	S/N	Supplier	Description	Unit	Qty Rec'd	Qty Used	Balance	Status
002	N860-4725- T201 and 121- 0041-0	7083943 and mv0000083333 6	MAXVISION CORPORATION	MAXVISION KEYBOARD MODEL #FKB4725-201	Each	1		1	
002	851252-0000 and 121-0008-2	LZB10200179 and MV0000083099	MAXVISION CORPORATION	LOGITECH MOUSE	Each	1			
001			MAXVISION CORPORATION	ACCESSORIES-- VERBATIM CD-RW BLANK 4X-10X SPEED TAIYO YUDEN CDR-74SY BLANK 16X SPEED PLEXWRITER OPERATIONS MANUAL PLEXTOR MANAGER 2000 UTILITIES & MORE USER'S GUIDE PLEXTOR ATAPI DRIVE INSTALLATION ADAPTEC SOFTWARE RIBBON CABLE W/SCREWS	Each	1		1	
					Each	1		1	
					Each	1		1	
					Each	1		1	
					Each	1		1	
					Each	1		1	
					Each	1		1	
					Each	1		1	
					Each	1		1	
					Each	1		1	
003			MAXVISION CORPORATION	INSTALLATION SOFTWARE AND DOCUMENTS-- MICROSOFT 1-2 CPU EDITION SETUP DISKS, PRODUCT ID 08201-OEM- 0001956-21659 WINDOWS NT WORKSTATION CD V4.0 BASIC AND INSTALLTION GUIDE PERFORMANCE TECHNOLOGY MOTHERBOARD USER'S MANUAL (TYAN COMPUTER) TYAN COMPUTER DRIVER CD V2.70 RPX SERIES USERS MANUL CO-01 THERMAL MANAGEMENT CARD INSTRUCTIONS SHEET	Each	1		0	
					Each	1		1	
					Each	1		1	
					Each	1		1	
					Each	1		1	
					Each	1		1	
					Each	1		1	
	27-0044-0	MV0000084523		Each	1		1		

Inven- tory Tag Number	P/N	S/N	Supplier	Description	Unit	Qty Rec'd	Qty Used	Balance	Status					
004		MV0000087538	MAXVISION CORPORATION	MAXRAX 7200 W/TYAN 2567 MOTHERBOARD COMPUTER--	Each	1		1						
		109-0120-0								MV0000083328	18.2 ULTRA2 10,000	0		
		215-0247-0								TY1D50110543	BRD, TYAN S2567U3AN	0		
		104-0003-0								MV0000071490	IND FERRITE CLAMP	0		
		103-0082-0								MV0000085191	AMERICAN PRO IMAGE RMCS600B W/DUAL 400 W	0		
		114-0084-0								MV0000083531	1 GHZ PENTIUM III FCPGA (133 FSB)	0		
		114-0084-0								MV0000084320	1 GHZ PENTIUM III FCPGA (133 FSB)	0		
		206-0060-0								MV0000084947	512MB DIMMS PC133 ECC REGISTERED	0		
		206-0060-0								MV0000084948	512MB DIMMS PC133 ECC REGISTERED	0		
		201-0097-0								MV0000074716	CABLE 24" 2 TO 3 AUDIO	0		
		109-0120-0								MV0000083327	18.2 ULTRA2 10,000	0		
		109-0138-0								MV0000084496	ZIP 250MB ATAPI INTERNAL	0		
		109-0144-0								MV0000085102	HITACHI DVD-ROM 2.6GB ATAPI STANDARD 1.44MB FLOPPY BIEGE	0		
		109-0005-0								MV0000084560	OXYGEN GVX1 PCI OPENGL GRAPHICS ACCEL 32MB	0		
	215-0145-013	MV0000021793	OXYGEN GVX1 PCI OPENGL GRAPHICS ACCEL 32MB	0										
	215-0145-013	MV0000063722	OXYGEN GVX1 PCI OPENGL GRAPHICS ACCEL 32MB	0										
	109-0140-010	MV0000084736	CDRW, PLEXTOR 12X/10X/32X	0										
	215-0145-010	MV0000066441	OXYGEN GVX1 APG OPENGL GRAPHICS ACCEL 32MB	0										
086		TT055056	CRUTCHFIELD	NHT SUPERZERO XU LOADSPEAKERS	Each	1		1						
085		TT055058	CRUTCHFIELD	NHT SUPERZERO XU LOADSPEAKERS	Each	1		1						
096		12510203	UNIVISIONS VIDEO SYSTEMS, INC.	JVC PROJECT MODEL DLA-S15U W/POWER CORDS, VIDEO CONNECTORS, ADAPTER CODES, REMOTE	Each	1		1	Returned to Customer on 10/25/01					

Inven- tory Tag Number	P/N	S/N	Supplier	Description	Unit	Qty Rec'd	Qty Used	Balance	Status
098		12510260	UNIVISIONS VIDEO SYSTEMS, INC.	JVC PROJECT MODEL DLA-S15U W/POWER CORDS, VIDEO CONNECTORS, ADAPTER CODES, REMOTE	Each	1		1	
097		12510221	UNIVISIONS VIDEO SYSTEMS, INC.	JVC PROJECT MODEL DLA-S15U W/POWER CORDS, VIDEO CONNECTORS, ADAPTER CODES, REMOTE	Each	1		1	
103		751385	UNIVISIONS VIDEO SYSTEMS, INC.	RGB SUPERVIEW 1000 SPECTRUM MODEL 1000-4 W/VIDEO ADAPTER CABLES (2), POWER CORD, SERIAL ADAPTER CABLE, SUPERVIEW 1000/VGA PLUS VIDEO WINDOWING SYSTEM USER MANUAL (1)	Each	1		1	
113	WAT-902C	E04917	WATEC	CAMERA BODIES	Each	1		1	
114	WAT-902C	E05049	WATEC	CAMERA BODIES	Each	1		1	
115	WAT-902C	E04938	WATEC	CAMERA BODIES	Each	1		1	
063	H0614FICS-3	N/A	COMPUTAR	CAMERA LENS	Each	3		3	
065	N/A	N/A	N/A	MOUNTED UV FILTERS	Each	3		3	
066	N/A	N/A	N/A	MOUNTED RED DICHROIC FILTERS	Each	3		3	
511	N/A	N/A	N/A	30.5mm TO 37mm STEPPING RING	Each	3		3	
512	N/A	N/A	N/A	37mm TO 58mm STEPPING RING	Each	3		3	
119	851-00	N/A	PANAVISE	CAMERA MOUNT UPPER KNUCKLE	Each	6		6	
121	856-03	N/A	PANAVISE	CAMERA MOUNT 3" SHAFT	Each	3		3	
118	856-03	N/A	PANAVISE	CAMERA MOUNT 6" SHAFT	Each	6		6	
120	860	N/A	PANAVISE	CAMERA MOUNT TRI-FOOT BASE	Each	3		3	
036	N/A	N/A	SAMSON	SERVO 260 STEREO POWER AMPLIFIER	Each	1		1	
108	95880-2	5850-058863	COMTROL	MULTIPOINT SERIAL CARD	Each	1		1	
034	D/41EPCI	N/A	DIALOGIC	VOICE PROCESSING CARD	Each	1		1	
006	AS-66	A011072	SKUTCH	TELEPHONE LINE SIMULATOR	Each	1		1	
509	CT10	000902779	PLANTRONICS	CORDLESS HEADSET TELEPHONE	Each	1		1	
007	N/A	C0101336398	LITE-ON BOARD	WIRELESS KEYBOARD UNIT	Each	1		1	
005	GP9455-001	N/A	GYRATION	GYROMOUSE PRESENTER	Each	1		1	
111	1522	N/A	ULTRASPEC	VGA TO 5 BNC CABLES	Each	2		2	

Inven- tory Tag Number	P/N	S/N	Supplier	Description	Unit	Qty Rec'd	Qty Used	Balance	Status
064	274-320	N/A	RADIO SHACK	MONO AUDIO ADAPTERS	Each	1		1	
110	RG-59	N/A	RADIO SHACK ACTION ELECTRONICS	12' VIDEO CABLES-BB12	Each	3		3	
067	630-1046	N/A	RADIO SHACK	LASER POINTER	Each	1		1	
117	42-2481	N/A	RADIO SHACK	1/8" TO PHONO PLUG CABLE	Each	1		1	
109	278-1267	N/A	RADIO SHACK	50' 16-GAUGE SPEAKER WIRE	Spool	1		1	
112	278-316	N/A	RADIO SHACK	SPADE CONNECTORS	Each	1		1	
122	920-2419	N/A	N/A	2U RACKMOUNT KIT FOR RGB SPECTRUM	Each	1		1	
510	N/A	LW-139	AFRL	LASER TRACKER BOX	Each	1		1	
035	00SF17690720	N/A	STEWART FILMSCREEN	SCREEN AND FRAME	Each	1		1	
0018	T-70BIG8		Newark Electronics	T-70 Raceway Base	Feet	12		12	
0018	T-70CIG8		Newark Electronics	T-70 Raceway Cover	Feet	12		12	
0050	N/A	13680314	AFRL	JVC PROJECT MODEL DLA-S15U w/POWER CORDS, VIDEO CONNECTORS, ADAPTER CODES, REMOTE	Each	1		1	

APPENDIX B – VOEKLER DRAWINGS

PICTURES OF THE AUTOCAD DRAWINGS

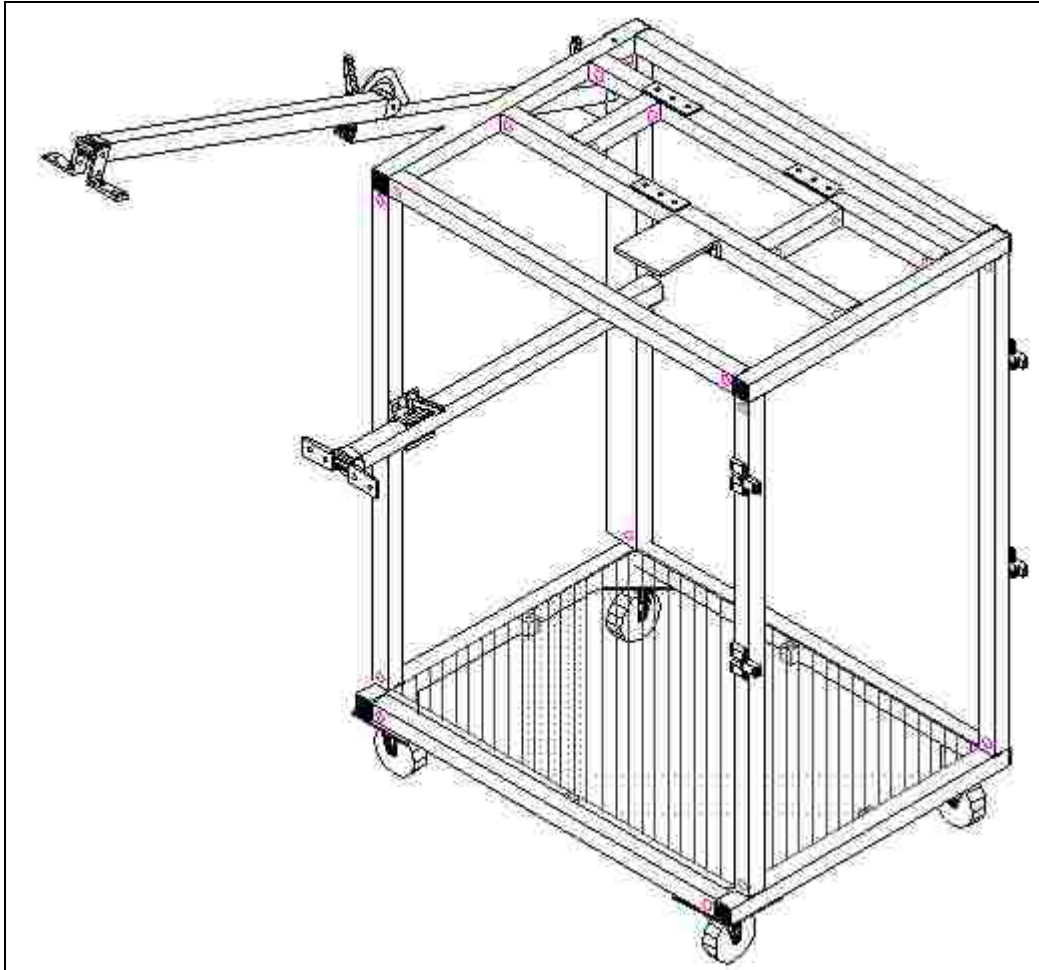

**Figure B-1 - Left Cart
(Right Cart is the mirror image of the Left Cart)**

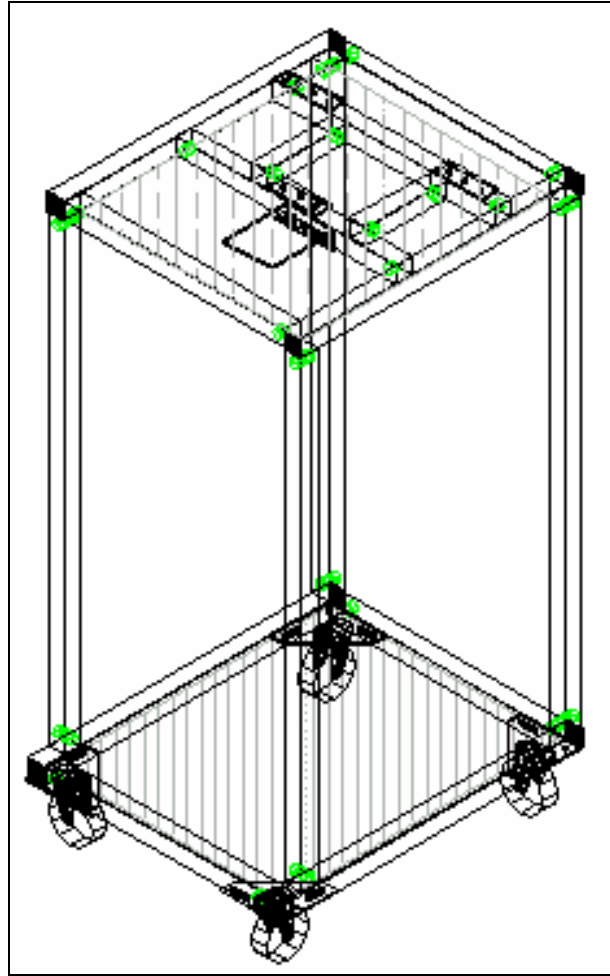

Figure B-2 - Middle Cart

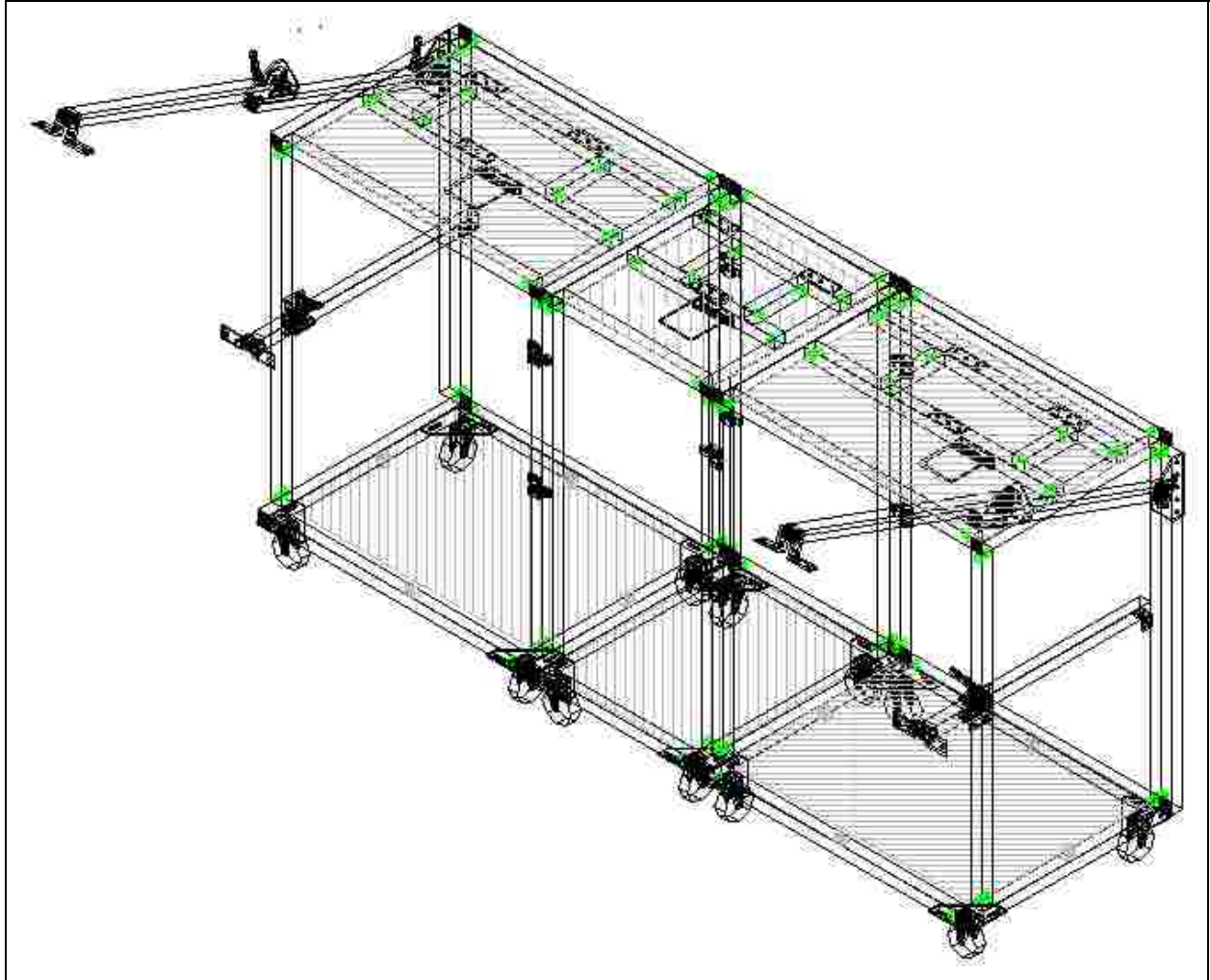

Figure B-3 - Fully-Assembled Cart

APPENDIX C – ASSEMBLY PLAN

1.0 EXECUTIVE SUMMARY

This document is the Assembly Instructions for the *Portable Interactive Data Wall (PIDW)* Transition to Production Program. The objective of this document is to provide step-by-step procedures required to assemble a PIDW. *SYTRONICS* will use this document as a reference guide throughout the assembly process. The Portable Data Wall Engineering Drawings of the frame, provided by *Air Force Research Laboratory/CAISR Modeling and Simulation Branch (AFRL/IFSB)*, are referenced multiple times throughout this document. These drawings provide the hardware and installation details required for the PIDW assembly.

2.0 ACQUIRE FRAME FROM VENDOR

SYTRONICS will subcontract the manufacture of the PIDW frame to a local vendor. A vendor will be selected based on capability, cost, and availability to perform the work. Seven vendors were identified and evaluated. Three vendors have been selected to submit bids. Additionally, *AFRL/Crew System Interface Division (HEC)* WPAFB has facilities that may be available to build the frame in collaboration with *SYTRONICS*. *SYTRONICS'* approach is to keep multiple vendors qualified in order to maintain competition and schedule availability. The following have been asked to submit bids.

Specialty Sheet Metal
1415 Stanley Avenue
Dayton, OH
937-222-0302

Miami Valley Manufacturing
4120 Industrial Lane
Beavercreek, OH
937-426-6114

Mantych Metal Working
3175 Plainfield Road
Kettering, OH
937-258-1373

The selected vendor will manufacture the PIDW frame in compliance with the AFRL/IFSB provided Engineering Drawing Numbers X20011026 to X20011064, dated 13 June 2001.

3.0 ACQUIRE REQUIRED HARDWARE

Table 3.0-1 lists the hardware that is required for the assembly of the PIDW, the part numbers, and the vendor information. Lead-time on delivery, shipping costs, etc., will be presented in the Production Plan.

TABLE 3.0-1: REQUIRED HARDWARE

#	ITEM	QTY	PART NUMBER	VENDOR	PHONE NUMBER
1	RGB Spectrum Super-View™ 1000-4	1	RGB 1000-4	Univisions Communication Group	800-836-0604
2	2V Rackmount Kit for RGB Spectrum	1	920-2419	Univisions Communication Group	800-836-0604
3	JVC SXGA Projector DLA-S15U	3	DLA-S15U	Univisions Communication Group	800-836-0604
4	Maxvision MAXRAX Computer System	1	MAXRAX 7200 w/Tyan 2567 Mthbrd	MaxVision (Storm Swendsboe)	800-533-5805, x203
5	Watec WAT-902C Camera Bodies	3	WAT-902c	Rock House Products Intern., Inc	888-919-2263
6	Computar H0614FICS-3 Camera Lens	3	HO614FICS-3	Rock House Products Intern., Inc	888-919-2263
7	Mounted Red Dichroic Filters	3	H53942	Edmund Scientific	856-573-6250
8	Mounted UV Filters	3	H54046	Edmund Scientific	856-573-6250
9	30.5mm to 37mm stepping ring	3	KSK30.5-37	Warehouse Photographic	800-400-8203
10	37mm to 58mm stepping ring	3	KSK37-58	Warehouse Photographic	800-400-8203
11	Panavise #851 Camera Mount, Upper Knuckle	6	PANAVISE851	Spytown	718-380-8000
12	Panavise #856-03 Camera Mount, 3" Shaft	3	PANAVISE856-03	Spytown	718-380-8000
13	Panavise #856-06 Camera Mount, 6" Shaft	6	856-06	Spytown	718-380-8000
14	Panavise #860 Camera Mount, Tri-foot Base	3	PANAVISE860	Spytown	718-380-8000
15	Samson Servo 260 Stereo Power Amplifier	1	Servo 260	SAMASH.COM	800-472-6274, x2226
16	Comtrol 95880-2 Multiport Serial Card	1	95880-2	CDW Government Inc.	800-906-4239
17	NHT Superzero XU Loudspeakers	2	228SZXUB	Crutchfield	888-955-6000
18	Dialogic D/41EPCI Voice Processing Card	1	D/41EPCI	CDW Government Inc.	800-906-4239
19	Skutch AS-66 Telephone Line Simulator	1	SKUTCH AS-66	Skutch Electronics	916-786-6186
20	Plantronics CT10 Cordless Headset Telephone	1	CT10	Lyme Computer Systems	800-370-1095
21	Lite-On Airboard Wireless Keyboard Unit	1	LITEONAIRBOARD	Lyme Computer Systems	800-370-1095
22	Gyration Gyromouse Presenter	1	GP9455-001	Gyration	800-316-5432
23	Ultraspec #1522 VGA to 5 BNC Cables	2	1522	Ultraspec Cables, Inc.	800-622-2537

#	ITEM	QTY	PART NUMBER	VENDOR	PHONE NUMBER
24	Radio Shack 274-320 Mono Audio Adapters	1	274-320	Radio Shack	800-442-7221
25	Action Electronics 12' RG-59 Video Cables - BB12	3	BB12	Action Electronics	800-834-4605
26	Radio Shack 630-1046 Laser Pointer	1	630-1046	Radio Shack	800-442-7221
27	Radio Shack 42-2481 1/8" to Phono Plugs Cable	1	42-2481	Radio Shack	800-442-7221
28	Radio Shack 278-1267 50' 16 Gauge Speaker Wire	1	278-1267	Radio Shack	800-442-7221
29	Radio Shack 278-316 Spade Connectors	1	278-316	Radio Shack	800-442-7221
30	#12 Black THHN	25 ft	TBD	Newark Electronics	937-294-8982
31	#12/2 w Grd SSO Cord	100 ft	TBD	Newark Electronics	937-294-8982
32	Male Cord Ends	2	TBD	Newark Electronics	937-294-8982
33	Female Cord Ends	2	TBD	Newark Electronics	937-294-8982
34	Recessed Male Plug In	2	TBD	Newark Electronics	937-294-8982
35	Brown Duplex Receptacles	12	TBD	Newark Electronics	937-294-8982
36	G-Slotted Wall Duct 2" x 2"	6 ft	G2X2LG6	Panduit	888-506-5400, x6914
37	FS Solid Wall Duct 2" x 2"	10 ft	FS2X2LG6	Panduit	888-506-5400, x6914
38	Solid Cover 2"	18 ft	C2LG6	Panduit	888-506-5400, x6914
39	T-70 Raceway Base	12 ft	T-70BIG8	Panduit	888-506-5400, x6914
40	T-70 Raceway Cover	12 ft	T-70CIG8	Panduit	888-506-5400, x6914
41	T-70 End Cap Fittings	6	T70EC1G	Panduit	888-506-6400, x6914
42	T-70 Entrance End Fittings	2	T-70EE1G	Panduit	888-506-5400, x6914
43	T-70 Device Bracket	12	T-70 HB-X	Panduit	888-506-5400, x6914
44	T-70 Snap-On Face Plate	12	T-70 PIG	Panduit	888-506-5400, x6914
45	Stewart Rear Projection Screen and Frame	1	SFC 32x111	Stewart Screening	877-752-7629

4.0 ACQUIRE AND INSTALL REQUIRED SOFTWARE

All software required for the assembly of the PIDW will be provided by AFRL/IFSB or the manufacturer of the equipment. The following software will be installed on the MAXRAX 7200 computer system as instructed by AFRL/IFSB.

- Custom laser pen tracking software
- Custom and *Commercial-Off-The-Shelf (COTS)* voice recognition software
- Custom bitmap images
- Video Windows software (software that allows the PC to control the SuperView™)

5.0 INSTALL ELECTRICAL APPARATUS

The data wall frame is comprised of three separate components: left, middle, and right. Electrical equipment must be installed on each of the left and right components as follows.

Left Component

20-AMP Circuit

Left Upper Power Strip

Left Lower Power Strip

Right Component

20-AMP Circuit

Right Upper Power Strip

Right Lower Power Strip

Two separate 20-AMP circuits must be installed on each of the left and right units, respectively. Each of the power strip assemblies will be three duplex units. The upper and lower assemblies must be connected by conduit to run on the same 20-AMP circuit.

The upper assemblies must be installed underneath the top shelf of each of the left and right components.



The lower assemblies must be installed on the bottom shelf of each of the left and right components.



Engineering drawings of the electrical assemblies are not available at this time. **SYTRONICS** personnel will assemble the electrical apparatus based on pictures of the assemblies and the following materials list provided by AFRL/IFSB without prejudice.

NOTE: The following materials are included in the hardware requirements list in Table 3.0-1.

5.1 Materials Required for the Electrical Assembly

- 25 feet #12 Black THHN
- 100 feet #12/2 with Ground SSO Cord
- 2 each Male Cord Ends
- 2 each Female Cord Ends
- 2 each Recessed Male Plug-in
- 12 each Brown Duplex Receptacles
- Panduit Raceway
 - 6 feet G-slotted Wall Duct
 - 10 feet FS-slotted Wall Duct
 - 18 feet Solid Cover
 - 12 feet T-70 Raceway Base
 - 12 feet T-70 Raceway Cover
 - 6 each T-70 End Cap Fittings
 - 2 each T-70 Entrance End Fittings
 - 12 each T-70 Device Bracket
 - 12 each T-70 Snap-on Face Plate

6.0 ASSEMBLE THE PIDW FRAME

Following the installation of the electrical apparatus, the PIDW frame components need to be assembled into one unit. The following instructions describe the assembly process. Refer to Engineering Drawing Number X20011026 for assembly details.

STEP 1: Position the left, middle, and right units next to each other on a *flat and level* surface. Connect the units using the guide pins to align the components.



STEP 2: Bolt the units together as detailed in the engineering drawing.



The frame may be placed on its side for easier access to the bottom of the unit.



7.0 INSTALL ARM ASSEMBLIES AND PROJECTION SCREEN FRAME

The adjustable arms (pictured below, attached to the PIDW frame) will hold the Stewart rear projection screen and screen frame. The arm assemblies will be manufactured with the PIDW frame, but will not be attached to the frame when it is delivered from the vendor. There are four arm assemblies that need to be installed on the frame--two upper and two lower assemblies. The upper arm assemblies attach to the outer sides of the left and right frame units. These will support the top portion of the projection screen frame. The lower arm assemblies attach to the inner sides of the left and right frame units. These will support the bottom portion of the projection screen frame. The following instructions describe the installation process. Refer to Engineering Drawing Number X20011026 for installation details.



STEP 3: Align the left upper arm assembly with the adjustable angle bracket bolted to the outer left leg of the back of the PIDW frame.



STEP 4: Bolt the upper arm assembly in place as detailed in the engineering drawing.



STEP 5: Secure the arm in the extended position using the ball lock pin supplied by the manufacturer.

NOTE: Secure the pin to the PIDW frame by attaching a cord. Loop and crimp the cord to the pin and rivet to the PIDW frame.



STEP 6: Repeat the above process for the right side of the frame.

STEP 7: Align the left lower arm component with the adjustable angle bracket bolted to the inside left leg of the front of the PIDW frame and bolt into place as detailed in the engineering drawing. Secure the arm in the extended position using the ball lock pin supplied by the manufacturer. Repeat for the right side.



The extended inner arms, which support the bottom of the screen frame, should be approximately 41 inches from the ground. This will place the screen at the approximate height for proper image projection.



STEP 8: Use clamps to secure the Stewart rear projection screen frame to the PIDW frame arm assemblies. Refer to the engineering drawing for approximate location.



Before the projection screen frame can be bolted to the arms, precise calibration and alignment procedures must be followed. This will be discussed in Section 9.0.

8.0 ATTACH PROJECTORS TO THE SLIDE-PLATES

The three JVC SXGA projectors must be attached to the slide-plates so the position of the projectors on the frame can be adjusted once the PIDW is assembled. The slide-plates, pictured below, are two metal plates that are manufactured with the frame.



When assembled, the slide-plates are designed to slide forward and backward and side-to-side across each other. Each projector will be bolted to the top slide-plate allowing the projector to be adjusted both left and right and forward and backward from the screen.

Two mounting screws provided with the projectors will be used to connect the projector to the projector plate. They will be installed with adjustment wheel thumbnuts which will allow adjustments of the projector angle and height. The adjustment wheel thumbnuts will be manufactured with the frame. The mounting bolts will be provided with the projectors, but must be modified or replaced before mounting. The bolts that are provided are hex head bolts. These must be modified to flathead screws so that they will be flush with the bottom of the top plate enabling it to slide over the bottom plate. If not modified, the bolts must be replaced with an equivalent flathead screw. A **SYTRONICS** technician will perform any modifications. The following instructions describe the slide-plate and the assembly of the projector to the slide-plate. Refer to Engineering Drawing Number X20011031 for slide-plate assembly details.

STEP 9: Insert the flathead mounting screws into the two countersunk mounting holes on the top slide-plate and thread a washer and lock nut onto the screws as detailed in the engineering

drawing.



STEP 10: Thread the adjustment wheel thumb nuts detailed in the engineering drawing onto the mounting screws.

STEP 11: Tighten the set screw in the adjustment wheels.



STEP 12: Turn the projector over and set it on a table with the bottom side up. Remove the rubber feet and the existing attached adjustment wheel to expose the mounting holes on the bottom of the projector.



STEP 13: Position the top slide-plate over the projector aligning the mounting screws with the mounting holes and thread the screws through the mounting holes on the projector by turning the adjustment wheel thumb nuts.



STEP 14: Secure the final mount to the plate with a third flathead machine screw as detailed in the engineering drawing.



STEP 15: Attach the top plate/projector assembly to the bottom plate as detailed in the engineering drawing.



9.0 PERFORM PRE-INSTALLATION ALIGNMENT AND CALIBRATION PROCEDURES

Precise calibration and alignment procedures are critical for the installment of the equipment on the Data Wall frame. Before installation can begin, the MAXRAX computer system, the JVC projectors, and the SuperView™ video box must be connected and running in order to project an image on the screen. This will allow the calibration and alignment procedures to take place so that the frame and projectors can be installed properly. No equipment is being permanently installed at this point. It is simply being positioned on the frame for alignment purposes. The following instructions describe the pre-installation process.

9.1 Pre-Installation Set-up

9.1.1 Equipment

STEP 16: Place the slide-plate-mounted JVC projectors side by side and evenly spaced on the top of

the PIDW frame. The lens should face the projection screen frame and be approximately seven inches from the front edge of the frame.



STEP 17: Place the MAXRAX 7200 computer system on the bottom of the middle unit of the PIDW frame with the front of the system facing the projection screen frame.



STEP 18: Place the SuperView™ video processor on top of the MAXRAX computer system on the middle unit of the PIDW frame. The front of the system should face the projection screen frame.

9.1.2 Cable Connections

The following section describes the cable connections for the equipment which will be used for the pre-installation alignment and calibration procedures. Refer to Figure 9.1.2-1 for a diagram of all cable connections. Numbers designated in the text correspond to the cable connections in the figure.

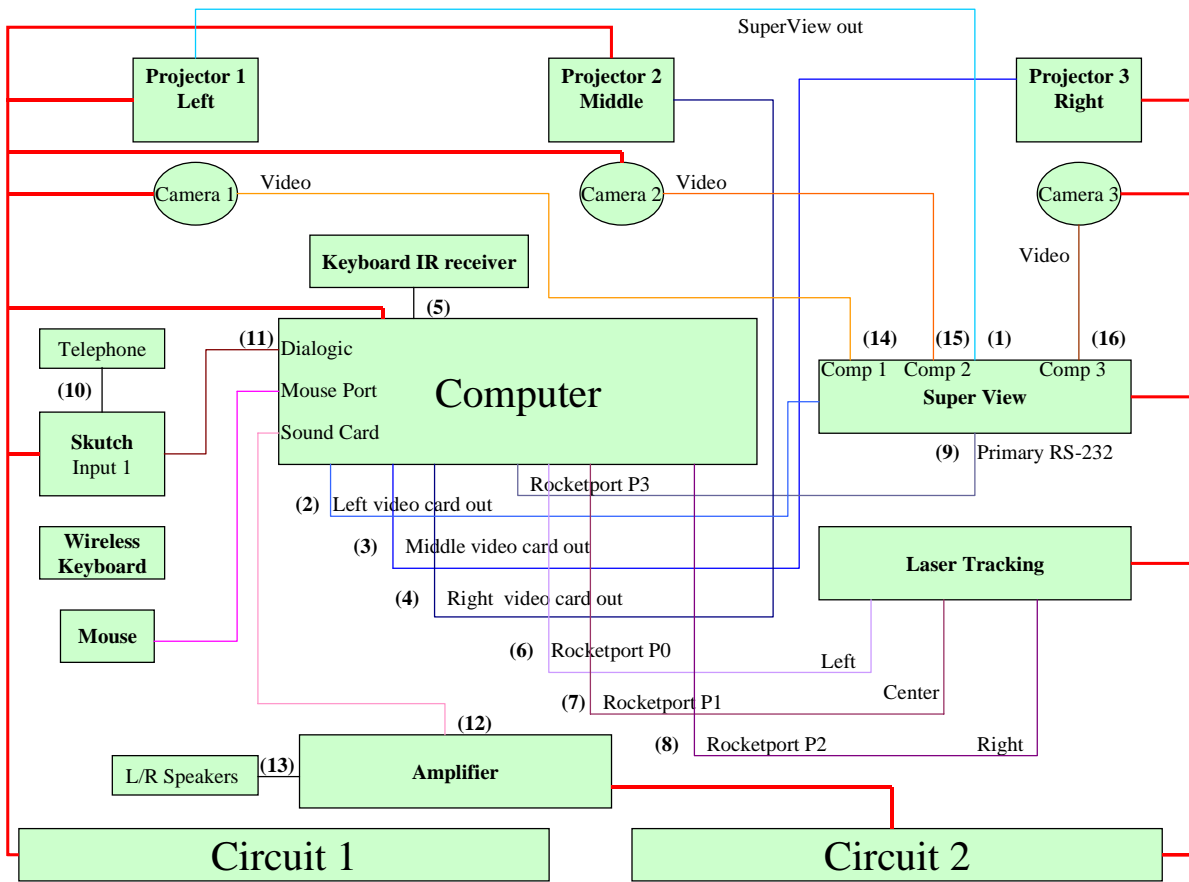

Figure 9.1.2-1. Cable Connections

9.1.2.1 Left Video Card to SuperView™ to Projector

STEP 19: Attach the two 13w3 to 5-part video connectors to the input and output of the SuperView™, respectively.



STEP 20: Plug the output from the SuperView™ into the input of the left projector (as seen from standing behind the projectors). Match the cable colors (1).



STEP 21: Use the ULTRASPEC VGA to 5-part video cable to run video from the output of the leftmost video card (as seen from the back of the computer) to the input of the SuperView™ (looping computer's video into SuperView™) (2).

9.1.2.2 Right and Middle Video Cards to Projectors

STEP 22: Use the second ULTRASPEC VGA to 5-part video cable to run video from the output of the middle video card to the input of the rightmost projector (as seen from the back of the computer) (3).

STEP 23: Use the third ULTRASPEC VGA to 5-part video cable to run video from the output of the rightmost video card (as seen from the back of the computer) to the input of the middle projector (4).



9.1.2.3 Keyboard Infrared (IR) Receiver to Computer

STEP 24: Connect the keyboard IR receiver to the computer (refer to the keyboard user's manual) (5).

9.1.2.4 Power Supply

STEP 25: Connect the equipment to the Power Supply Units.

IMPORTANT: Due to the power draw of the equipment, it is important not to overload the 20-AMP circuits. Two of the projectors should be powered by one circuit. The computer and the third projector should be powered by the other circuit. The remaining equipment can be plugged into any available (or closest) outlet. Refer to red lines in Figure 9.1.2-1 for power supply connections.

STEP 26: Take the lens covers off of the projectors and power up the equipment.

9.1.3 Projector Screen

STEP 27: Attach the Stewart rear projection screen to the frame by snapping it into place. The screen is marked top and bottom. Carefully touch only the border of the screen as oils from the skin may damage it.



9.2 Pre-Installation Alignment and Adjustments

9.2.1 PIDW Frame Arm and Screen Frame Adjustments

For proper image projection, it will be necessary to adjust the distance from the screen frame to the ground and the distance from the PIDW frame to the screen frame. The screen frame must also be adjusted to be plumb and level. This is accomplished by adjusting the PIDW frame arms and securing them with clamps on the screen frame as detailed in Engineering Drawing Number X20011026. The screen frame will not be bolted to the arms until the final installation. The following instructions describe the adjustment procedures.

9.2.1.1 Distance from Ground

The distance of the bottom of the screen frame to the ground is approximately 41 inches. Adjustments should be made at the installation points of the arm assemblies as detailed in Engineering Drawing Numbers X20011026, X20011029, and X20011030.

NOTE: Stabilize the screen frame with a bottle jack or some other form of equipment while making the adjustments.

STEP 28: Loosen the bolts, which attach the arms to the frame, and shift the arms up or down until the distance of the frame to the ground is 41 inches.



9.2.1.2 Distance from PIDW Frame

The approximate value for the distance of the screen frame from the PIDW frame is 29 inches.

STEP 29: Adjust the distance by shifting the arms backward or forward until the distance is 29 inches.

9.2.1.3 Plumb and Level

STEP 30: Adjust the upper arm assemblies forward or backward until the frame is plumb and level.



9.2.2 Projector Adjustment and Alignment

STEP 31: With the JVC remote supplied with the projectors, use the "options" settings to set the projectors for rear projection (refer to the user's guide provided with the projectors).

STEP 32: Use the wireless keyboard to open the Windows display properties and select background (refer to the Windows User's Guide provided with the computer system package).

STEP 33: Set the video mode to 3840 x 1024 and the color palette to true color in the display settings of Windows NT.

9.2.2.1 Tracking and Phase Adjustments

STEP 34: Use the wireless keyboard to set the background pattern to an alternate sequence of vertical lines by selecting the "**altlines.bmp**" file.



STEP 35: Use the JVC remote to select a projector and bring up the menu. Refer to the JVC User's Guide for details on adjusting tracking and phase.

9.2.2.2 Focus

STEP 36: Use the wireless keyboard to set the background pattern to the squares by selecting the "**squares.bmp**" file. This will be used to perform focus adjustments.



STEP 37: Use the JVC remote to select a projector and press the focus adjustment buttons on the remote to focus. Refer to the JVC User's Guide for details on focusing.

9.2.2.3 Alignment of the Projectors

The alignment of the projector images is a precise and somewhat complex procedure. When the screen is attached to the frame, there is some bowing in the center of the frame from the tension of the screen. The projector alignment includes the calculation of the view area dimensions based on the screen resolution and the aspect ratio in relation to the bow in the screen.

STEP 38: Determine the center point of the width of the projection screen and mark the frame at that point (approximately 54 inches).

STEP 39: Hang a plumb line over the frame at the center point for a straight guide line.

STEP 40: Use the keyboard to set the Windows Background Pattern to the grid pattern by selecting the "**grid.bmp**" file. This will allow the projectors to be aligned with respect to each other.

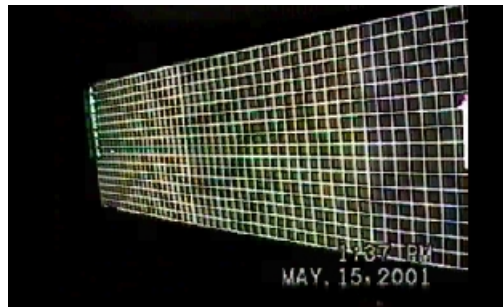

STEP 41: Turn off the two end projectors, leaving only the middle grid projection on the screen.

At this point, some gridlines may be missing from the viewing area, the grid may be tilted, or the grid may be too high or low on the screen.

STEP 42: Use the JVC remote to select **Position** from the menu.

STEP 43: Adjust the image by clicking left, right, up, or down until all gridlines are viewable and all pixels are displayed in the view area.

NOTE: Some of the image may not be projected in the viewable portion of the screen as the projectors have yet to be aligned.

STEP 44: Repeat this process for all three projectors.

STEP 45: If necessary, use the adjustment wheels referred to in Section 8.0 to adjust the projector height and angle.

IMPORTANT: The following calculations must be performed to account for the bow in the screen frame.
--

The resolution of each projection area is 1280 x 1024, which is a five to four ratio. The

image is 36 inches wide. Using that information, the height of the image area should be 28.8 inches based on the following calculations.

$$\begin{aligned}5/4 &= 36/x \\5x/5 &= 144/5 \\x &= 28.8\end{aligned}$$

STEP 46: Measure the vertical screen height at the center point of the screen to determine the actual height of the bowed screen image area.

STEP 47: Solve for x in the following equation to determine the recalculated image width to compensate for the bow in the screen.

$$\begin{aligned}5/4 &= x/\text{Vertical Screen Height} \\4x/4 &= 5(\text{Vertical Screen Height})/4 \\x &= \text{Recalculated Image Width}\end{aligned}$$

STEP 48: Line up the center line of the grid with the center line of the screen.

STEP 49: Adjust the image area to the recalculated image width by manipulating the slide-plates on the projector.

STEP 50: Measure and adjust the left and right image areas to the recalculated image width as well.

STEP 51: Move the projectors so that the lenses are the same distance from the screen as the recalculated image width since the distance of the projector from the projection surface and the horizontal width of the image is a one-to-one ratio.

9.2.3 Final Pre-Installation Alignment and Adjustments

At this point, alignment and adjustment procedures are projector-dependent and become a visual process. It may be necessary to adjust the frame left or right or adjust the projectors somewhat in order to make everything "look right." This is an iterative process involving multiple adjustments. Primary concerns are as follows.

- The center line of the middle grid should be on the center line of the screen frame.
- The width of the image areas should be adjusted to compensate for the bow in the screen frame.
- The grids for each projector should be fully viewable on the screen, aligned with each other, and have no separation between the image areas. There may be some separation between the lower and upper corners of the grids where the screen attaches to the frame, as shown below.

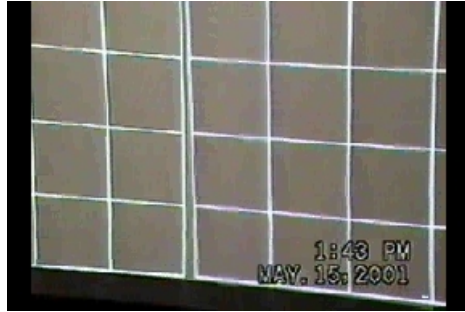

- This separation is due to variable tension in the screen at those points. Some separation cannot be prevented, but adjustment should be made to allow as little separation possible.

10.0 PERFORM PIDW SET-UP PROCEDURES

This section describes the installation of the equipment on the Data Wall frame. The pre-installation calibration and alignment procedures provided information that was critical in determining the placement of the equipment on the PIDW frame. The following sections describe installation of the equipment based on that information.

10.1 Hardware Installation

10.1.1 Screen Frame

After final adjustments have been made to the screen frame during the pre-installation procedures, the screen frame can be attached to the PIDW frame arms.

STEP 52: Collapse the arms and check for obstacles. If they do not collapse without hindrance, some minor adjustments may need to be performed. Ensure that alignment and calibration of the projection image is maintained while making any adjustments to the arms.

STEP 53: Mark the screen frame where the arms are to be attached.



IMPORTANT

STEP 54: Remove the screen from the frame.

STEP 55: Adjust and add clamps as needed to secure the screen frame, making sure the point where

the drill holes will be marked is accessible.



STEP 56: Use a punch to mark all the drilling points on the screen frame.



STEP 57: Remove the screen frame from the PIDW frame arms.

STEP 58: Drill holes at the marked points. Refer to Engineering Drawing Number X20011030 for the size of the holes.



STEP 59: Install rivnuts and bolt the frame to the arms as detailed in Engineering Drawing Number X20011026.



10.1.2 Projectors

STEP 60: Clamp the projector slide-plates to the PIDW frame.

STEP 61: Use a punch to mark the frame at the center point of the sliding slots on the bottom slide-plates. There should be four markings for each plate.



IMPORTANT

STEP 62: Remove the projectors and other equipment from the frame.

STEP 63: Drill holes into the frame surface in which nut inserts will be installed. Smaller holes must be drilled first in preparation for drilling the larger holes. Refer to Engineering Drawing Number X20011026 to determine the size of the drill holes.

CAUTION: Clean up drilling residue after each drill to keep electrical units free from residue.

STEP 64: Drill a second set of larger holes in the frame at the same points as detailed in Engineering Drawing Number X20011026.



STEP 65: Install nut inserts as detailed in Engineering Drawing Number X20011026.



STEP 66: Clean the frame top.

STEP 67: Re-attach the projection screen.



STEP 68: Place the projectors on the frame with the inserts at the center point of each slide-plate adjustment slot.



STEP 69: Fasten the plates to the frame as detailed in Engineering Drawing Number X20011026.



10.1.3 Speakers

STEP 70: Attach the NHT speakers to the frame using the wall-mount brackets supplied with the speakers. Refer to Engineering Drawing Numbers X20011026 and X20011040 for speaker locations.



10.1.4 Stereo Amplifier

STEP 71: Secure the Samson stereo amplifier at the bottom of the rack in the middle frame unit.

10.1.5 Computer

STEP 72: Place the MAXRAX computer on top of the amplifier and screw into the rack.

10.1.6 AFRL Video Tracking System

STEP 73: Place the tracker on top of the computer and screw into the rack.

10.1.7 SuperView™ Video Box

STEP 74: Install the rackmount faceplate on the SuperView™. Place the video box on top of the tracker box and screw into the rack.

10.1.8 Wireless Keyboard Receiver

STEP 75: Place the receiver on top of the SuperView™ video box. This will not be screwed into the rack.

10.1.9 Telephone Line Simulator (AS-66 Skutch

STEP 76: Place the telephone line simulator on the top of the video box. This will not be screwed into the rack.

10.2 Cable Connections

The following section describes the final cable connections of the electronic PIDW equipment. Refer to Figure 9.1.2-1 for a diagram of the cable connections.

10.2.1 SuperView™, Projector, and PC Connections

STEP 77: Repeat pre-installation cable connections in Section 9.1.2.

10.2.2 Computer to Laser Tracker

STEP 78: Attach the 4-to-1 fan-out serial cable to the Rocketport serial card.



STEP 79: Attach P0 of the fan-out serial cable from the Rocketport serial card to the left input of the tracker box (6), P1 to the center input (7), and P2 to the right input (8).

10.2.3 Computer to SuperView™ Video Box

A special serial cable comes with the SuperView™ to control the SuperView™ via the serial port on the computer.



STEP 80: Plug the RGB end of the special SuperView™ cable into the port labeled "primary" on the SuperView™ (9).



STEP 81: Plug the 9-pin serial end into the P3-connector from the Rocketport serial card on the computer.



10.2.4 Skutch to Computer

STEP 82: Plug the telephone into Port 1 of the Telephone Line Simulator CAS-66 Skutch (10).



STEP 83: Plug the output from input 1 of the 4-port Dialogic telephony card in the PC into the Skutch box input 1 labeled "voice card" (11).



10.2.5 Amplifier to PC

STEP 84: Plug the output from the PC sound card to the input of the amplifier (12).

10.2.6 Speakers to Amplifier

STEP 85: Thread speaker wire through the frame wire channels located on the outermost legs of the frame (13).



STEP 86: Attach the bare ends of the wire to spade connectors and then attach the speakers.



STEP 87: Attach the other ends of the speaker wire to the spring-clip terminals on the stereo amplifier. Make sure that if the "white" stripe is plugged into the "positive" side of the speaker that the "white" stripe is plugged into the "positive" side of the amplifier.



10.3 Cameras

Three cameras will be installed on the PIDW, one for each of the three image areas. The purpose of the cameras is to provide live video of each section of the screen for processing by the laser pointer tracking system. The camera units must be assembled before they are installed on the PIDW unit. The following steps describe the assembly and installation of one camera. The procedure must be repeated for each of the remaining two cameras.

10.3.1 Camera Mount

STEP 88: Attach a Panavise camera mount six-inch shaft (Part No. 856-06) to the camera mount tri-foot base (Part No. Panavise860).

STEP 89: Attach a Panavise camera mount six-inch shaft (Part No. 856-06) to the six-inch shaft described above.

STEP 90: Attach a camera mount upper knuckle (Part No. Panavise851) to the second six-inch shaft described above.

STEP 91: Attach a Panavise camera mount three-inch shaft (Part No. 856-03) to the upper knuckle described above.

STEP 92: Attach a camera mount upper knuckle (Part No. Panavise851) to the three-inch shaft described above.

STEP 93: Ensure all connections on the camera mounts are tight.



10.3.2 Camera Assembly

STEP 94: Attach the camera lens (Part No. H0614FICS-3) to the camera body (Part No. WAT-902C).



STEP 95: Attach the 30.5mm-37mm stepping ring (Part No. KSK30.5-37) to the 37mm-58mm stepping ring (Part No. KSK37-58).



STEP 96: Attach the Dichroic color filter (Part No. H53942) to the stepping rings.

STEP 97: Attach the ultra violet glass filter (Part No. H54046) to the Dichroic color filter.



STEP 98: Attach the stepping ring assembly to the camera lens.



10.3.3 Camera Installation

Before installing cameras, power up all equipment so projection images appear on screen.

STEP 99: Attach the camera unit to the upper knuckle of the camera mount.



STEP 100: Position the camera mount tri-foot base on the PIDW frame in front of the projector such that the camera can be positioned above, and as close to, the projector lens as possible.

IMPORTANT: Ensure that the placement of the camera does not hinder the adjustment of the projector slide-plates. It should not be necessary to move the slide-plates more than one inch. Also, ensure the camera mount does not interfere with the projector image.



STEP 101: Connect the camera output to the SuperView™ video processor input while one person holds the camera in place (14)(15)(16).



STEP 102: Attach the power supply cable to the camera and plug the power supply of the camera into one of the outlets on the frame power strips.

STEP 103: Use the input panel on the front of the SuperView™ to toggle to "input one" and press the "Window On" button on the Super-View™. (Refer to SuperView™ manual for more information).



STEP 104: Use the arrow keys on the SuperView™ to move the window into position and adjust its size.

The SuperView™ window will appear on the right side of the projection screen (from front), which shows exactly what the camera is viewing at that time.



STEP 105: Use the wireless keyboard to select a projector. Adjust the window to the full size of the screen image by right clicking on the window frame and choosing "maximize window to screen."



STEP 106: Ensure that the full view of the window is visible for each projector. The purpose of displaying this window is to facilitate adjusting the camera to view the image area and little else.

STEP 107: Ensure that the frame arms do not appear in the view.

STEP 108: Trace around the camera mount base with a pencil and tighten the knuckles on the camera to prepare for installation.

STEP 109: Drill holes in the PIDW frame and bolt the camera assembly to the frame as detailed in Engineering Drawing Number X20011026.

11.0 PERFORM FINAL CALIBRATION AND ALIGNMENT PROCEDURES

11.1 Projection Image

STEP 110: Repeat alignment and adjustments procedures if necessary as described in Section 9.2.2, to ensure optimum projection images for the fully-assembled PIDW.

11.2 Laser Tracking

This section describes the iris adjustments to the cameras and the calibration of the laser pen to allow proper function of the laser tracking software.

11.2.1 Iris

STEP 111: Open the iris of each camera to full aperture.



STEP 112: Adjust the camera so that the entire screen is displayed. As previously discussed, it is important that the camera not view the frame arms or beyond the edge of the screen frame, as this will degrade or prevent the laser pen tracking.



STEP 113: Connect each camera to its respective "sync" input on the laser tracker box and adjust the iris in the camera for optimal laser tracking.

STEP 114: Verify by looking at the activity LEDs on the laser tracking box that the irises are wide open. All the lights should be on.



Slight overlap coverage by the camera is acceptable because this anomaly will be handled

by the laser pen tracking software.

STEP 115: Close the irises on each camera until the associated LEDs on the tracker box go out. This indicates that the camera does not see enough light to trigger the tracking software.

STEP 116: Shine the laser pen toward each screen and verify that each camera sees the light output from the pen by watching the LEDs on the tracker box. If a camera does not see the pen, open the iris a little bit and try again. It may take more several attempts to open the iris to the proper level.

STEP 117: Be sure that the tracker box is not falsely detecting the laserpen when not pointing directly at the screen. If any of the tracker box LEDs are flickering, the iris on that respective camera is open too much.

STEP 118: Use the laser pen to verify that the tracking software picks up laser pen clicks in the corners of the screen. The operator can tell if it sees the laser pen by watching the LEDs on the tracker box. If the pen does not trigger a tracker box response, the iris needs more adjustment.

11.2.2 Laser Pen

The software calibration routines supplied by AFRL will be used to calibrate the laser tracking software.

The software will display seven columns containing three small Xs. The first column will appear on the far-left side of the screen. The first X of the first column will appear on the top left, the second X will appear in the middle on the left and the third X will appear at the bottom left. The second column will appear in the middle of the left screen, the third column will appear on the seam of the left and middle screen, and so on across the three screens.

STEP 119: Use the laser pen to select the center of the X as it appears on the screen. The most accurate way to do this is to stand close to the screen and position the laser pen very close to the screen (about one inch away), making sure not to touch the screen with the fingers or the tip of the laser pen.

NOTE: It is possible that the first X of the first column will not appear in the visible viewing area of the screen. If this happens, use the laser pen to select the top left corner as close to the edge as possible. The top left corner is always the starting point.



As the operator selects each point, a message will be displayed on the screen registering the laser pen selection. It will also prompt the operator to select the next point by displaying a message like "at point 1," "at point 2," and so on.

STEP 120: Continue selecting points until each selection has been registered.

If the software fails to register a point (meaning the iris is not open enough or it is open too much), then the iris must be adjusted and the calibration must be restarted from point one.

The calibration routine must be performed for each Windows NT user account. If there are two user accounts on NT (e.g., "administrator" and "datawall") the calibration routine must be performed twice.

STEP 121: Close the software and restart it.

STEP 122: Set the background of each screen to bright white and verify that none of the tracker box LEDs are flickering. If any of them flicker, close the iris on the camera until it stops flickering.



12.0 PERFORM ACCEPTANCE TEST PROCEDURES

The Acceptance Test Plan is currently under development. **SYTRONICS** will perform the Acceptance Test following PIDW assembly.

13.0 INSTALL FINAL ALIGNMENT PINS

Once the Acceptance Test is complete, two holes should be drilled into each of the projector slide-plates, through the frame top, and through all frame adjustment points for alignment purposes. Pins will be inserted into these holes to verify that nothing has been inadvertently misaligned during transport. The top plate pins should be left in place. Pins will be inserted into the holes to align the plates with the frame so that the projectors will always be installed in the correct position.

<p>IMPORTANT: Before pin holes are drilled, the two locknuts on the projector bolts with thumbwheels need to be tightened securely to the top plate. This will prevent the thumbnut from moving prior to the final alignment. The bolts that secure the top slide-plate to the bottom slide-plate need to be tightened as well.</p>
--

APPENDIX D – PRODUCTION PLAN

1.0 INTRODUCTION

The ***Advanced Displays and Intelligent Interfaces (ADII)*** technology team of the Information Directorate of the Air Force Research Laboratory (AFRL/IF) in Rome, NY has successfully implemented a number of interactive datawalls. ***SYTRONICS, Inc.***, as a subcontractor to CACI Technologies, Inc., has constructed a ***Portable Interactive Data Wall (PIDW)*** based on the existing AFRL/IFSB PIDW design. This Production Plan details the features, frame production, components, representative vendor and sources, schedule, and shipping specifications associated with the construction of a PIDW.

2.0 FEATURES



- Designed for indoor use and can be easily rolled into location by two people.
- Disassembles into three separate units for easy transportation.
- Projection screen frame folds onto front of cabinet for shipping/storage purposes.
- Dimensions.
 - Fully assembled unit is 9 ¼'W x 5'H x 2 ¼'D with projection screen folded in.
 - Fully assembled unit is 9 ¼'W x 6 ¼ 'H x 4 ½ 'D with projection frame extended.

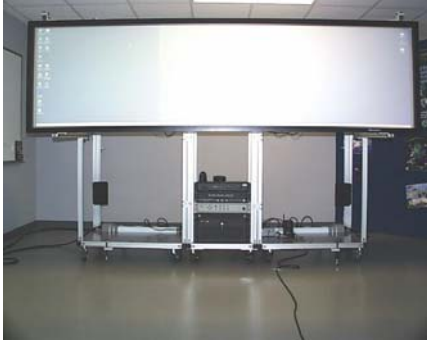

Figure 2.0-1. Fully-Assembled PIDW--Front View

Figure 2.0-2. Fully-Assembled PIDW--Side View

- Includes Dual Pentium III 1.0 GHz PC with three Oxygen GVX1 Graphic Cards.
- 1 x 3 LCD Projector Configuration displays 1280 x 1024 pixels each for a combined resolution of 3840 x 1024 pixels across a screen area of 9' x 2¼'.
- Features speaker-independent voice activation and a wireless pointing device using camera tracked laser pointers.
- Conventional computer mouse functionality also operable.

3.0 FRAME PRODUCTION

3.1 Vendor Information

Voelker Controls, a local distributor of 80/20 modular T-slotted aluminum framing systems, constructed the PIDW frame. Voelker Controls ordered all materials required for the manufacture of the frame, constructed the frame, and delivered the completed unit to Sytronics, Inc. Contact information is as follows:

Voelker Controls
Joe Derosa, Sales Specialist
3000 Commerce Center Drive
Franklin, OH 45005

3.2 AutoCAD Drawings

The PIDW frame was constructed in compliance with AutoCAD drawings prepared by Voelker Controls. These drawings were generated with the purpose of duplicating form, fit, and function of the original AFRL/IFSB three-piece PIDW design. Pictures of the AutoCAD drawings are attached in Appendix A.

3.3 Delivery

Allow two to four weeks for delivery of the frame.

4.0 COMPONENTS

4.1 Hardware

A list of all equipment and supplies (frame excluded) required to construct the PIDW is attached in Appendix B.

Information provided includes item description, part number, quantity, vendor, and contact information.

4.2 Software

The following Government Furnished Software is required for alignment and calibration procedures, laser tracking, and voice recognition of the PIDW.

- Custom Laser Pen Tracking Software
- Custom and COTS Voice Recognition Software
- Custom Bitmap Images

5.0 SCHEDULE

See Appendix C.

6.0 SHIPPING SPECIFICATIONS

6.1 Crate Construction

CASSIS Packaging Company constructed a crate and packaged the PIDW frame for shipping. Lead-time for construction of the crate is estimated to be two weeks. Contact information is as follows.

CASSIS Packaging Company
1235 McCook Avenue
Dayton OH 45404
POC: Sheila Cassis
937-223-8868

6.2 Shipping

The PIDW frame and all components were shipped using Yellow Freight Commercial Shipping Services.

APPENDIX A
PICTURES OF THE AUTOCAD DRAWINGS

PICTURES OF THE AUTOCAD DRAWINGS

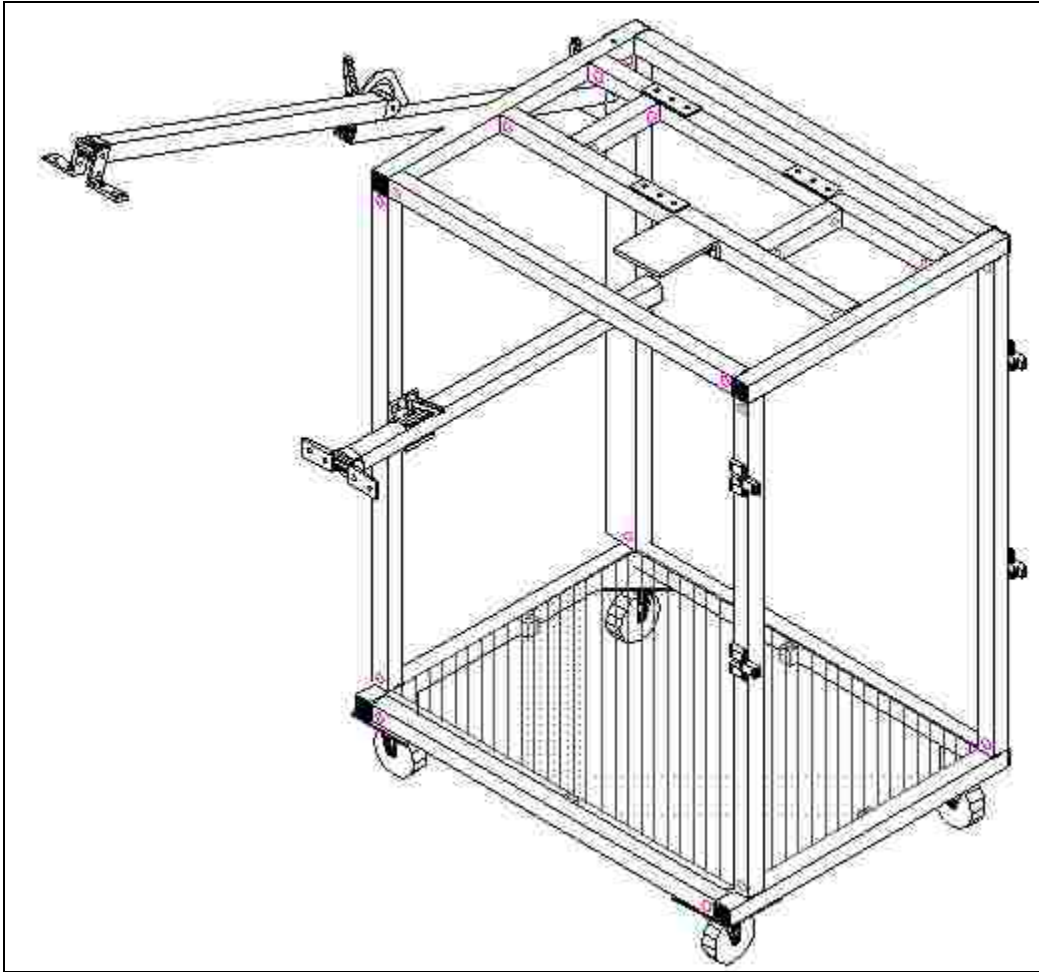

Left Cart
(Right Cart is the mirror image of the Left Cart)

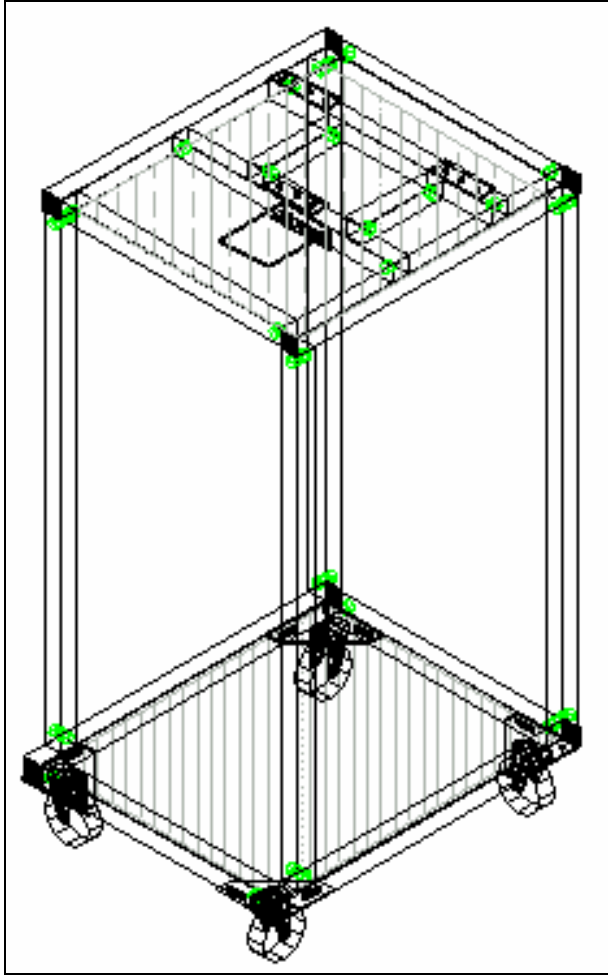

Middle Cart

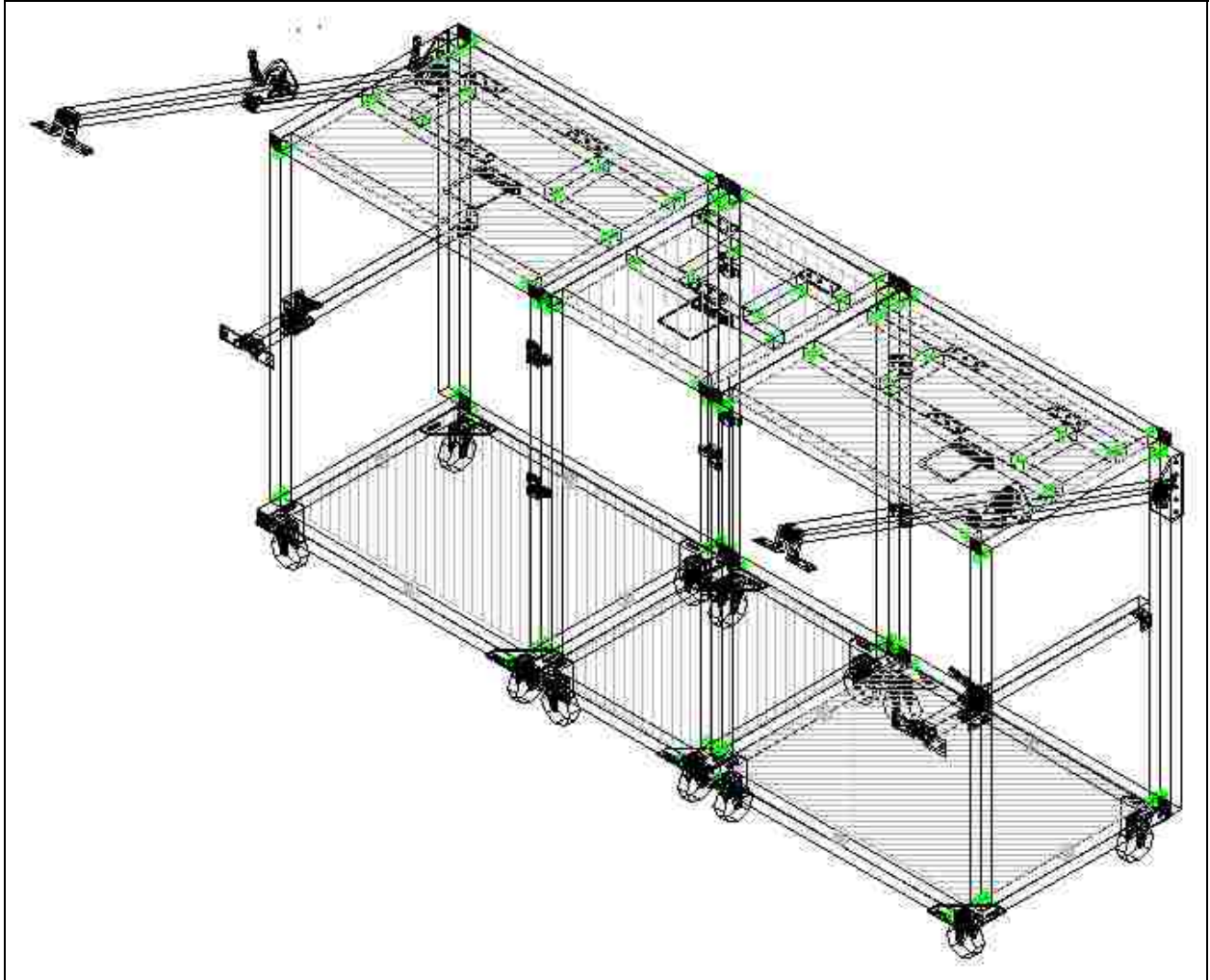

Fully-Assembled Cart

APPENDIX B
LIST OF EQUIPMENT AND SUPPLIES

LIST OF EQUIPMENT AND SUPPLIES

ID#	CATEGORY	ITEM DESCRIPTION	QTY	PART NUMBER	VENDOR	PHONE
1	Cameras	Watec WAT-902C Camera Bodies	3	WAT-902C (1 year parts and labor)	Rock House Products International, Inc.	888-919-2263
2	Cameras	Mounted Red Dichroic Filters	3	H53942	Edmund Scientific	856-573-6250
3	Cameras	Computar H0614FICS-3 Camera Lens	3	HO614FICS-3	Rock House Products International, Inc.	888-919-2263
4	Cameras	Mounted UV Filters	3	H54046	Edmund Scientific	856-573-6250
5	Cameras	Panavise #851 Camera Mount Upper Knuckle	6	PANAVISE851	Spytown	718-380-8000
6	Cameras	Panavise #856-06 Camera Mount 6" Shaft	6	856-06	Spytown	718-380-8002
7	Cameras	Panavise #856-03 Camera Mount 3" Shaft	3	PANAVISE856-03	Spytown	718-380-8001
8	Cameras	Panavise #860 Camera Mount Tri-Foot Base	3	PANAVISE860	Spytown	718-380-8003
9	Cameras	30.5mm to 37mm Stepping Ring	3	KSK30.5-37	Warehouse Photographic	800-400-8203
10	Cameras	37mm to 58mm Stepping Ring	3	KSK37-58	Warehouse Photographic	800-400-8203
11	Computer	Maxvision MAXRAX Computer System	1	MAXRAX 7200 with tyan 2567 Motherboard	MaxVision (Storm Swendsboe)	800-533-5805, x203
12	Computer	Dialogic D/41EPCI Voice Processing Card	1	D/41EPCI	CDW Government, Inc.	800-906-4239
13	Computer	Comtrol 95880-2 Multiport Serial Card	1	95880-2	CDW Government, Inc.	800-906-4239
14	Computer	Gyration Gyromouse Presenter	1	GP9455-001	Gyration	800-316-5432
15	Computer	Lite-On Airboard Wireless Keyboard Unit	1	SK7100	Lyme Computer Systems	800-370-1095
16	Electric	#12 THHN Black	25 ft	22900	Rexal	937-228-5141
17	Electric	#12 THHN White	25 ft	22910	Rexal	937-228-5141
18	Electric	#12 THHN Green	25 ft	22940	Rexal	937-228-5141
19	Electric	T-70 Entrance End Fittings	2	T-70EE1G	Newark Electronics	937-294-8980
20	Electric	Female Cord Ends (std)	2	84N1955	Newark Electronics	937-294-8980
21	Electric	Male Cord Ends (std)	2	84N1954	Newark Electronics	937-294-8980
22	Electric	Recessed Male Plug-In (std)	2	92N4454	Newark Electronics	937-294-8980
23	Electric	G Slotted Wall Duct 2"x 2"	6ft	G2X2LG6	Newark Electronics	937-294-8980
24	Electric	FS Solid Wall Duct 2"x 2"	10ft	FS2X2LG6	Newark Electronics	937-294-8980
25	Electric	T-70 Snap-On Face Plate	12	T-70 PIG	Newark Electronics	937-294-8980
26	Electric	T-70 Device Bracket	12	T-70 HB-X	Newark Electronics	937-294-8980
27	Electric	T-70 End Cap Fittings	6	T-70EC1G	Newark Electronics	937-294-8980
28	Electric	T-70 Raceway Base	12 ft	T-70BIG8	Newark Electronics	937-294-8980
29	Electric	Brown Duplex Receptacles	12	84N1926	Newark Electronics	937-294-8980
30	Electric	T-70 Raceway Cover	12 ft	T-70CIG8	Newark Electronics	937-294-8980
31	Electric	Solid Cover 2"	18 ft	C2LG6	Newark Electronics	937-294-8980
32	Electric	#12/3 SO Cord	100 ft	41860	Rexal	937-228-5141
33	Laser	Laser Tracking Box	1	GFE	Rome Laboratories	315-330-2136

ID#	CATEGORY	ITEM DESCRIPTION	QTY	PART NUMBER	VENDOR	PHONE
	Tracking					
34	Laser Tracking	Radio Shack 630-1046 Laser Pointer	1	630-1046	Radio Shack	800-442-7221
35	Projectors	JVC SXGA Projector DLA-S15U	3	DLA-S15U	Univisions Communication Group	800-836-0604
36	Projectors	Action Electronics 12' RG-59 Video Cables-BB12	3	BB12	Action Electronics	800-563-9405
37	Screen	Stewart Rear Projection Screen and Frame	1	9' x 2.25' Image/Flexible with Snapper Frame	Stewart Screening	310-784-5300
38	Audio	Samson Servo 260 Stereo Power Amplifier	1	ALESIS RA-100	SAMASH.COM	800-472-6274, x2226
39	Audio	NHT Superzero XU Loudspeakers	2	228SZXUB	Crutchfield	888-955-6000
40	Audio	Radio Shack 278-1267 50' 16 Gauge Speaker Wire	1	278-1267	Radio Shack	800-442-7223
41	Audio	Radio Shack 42-2481 1/8" to Phono Plugs Cable	1	42-2481	Radio Shack	800-442-7222
42	Audio	Radio Shack 278-316 Spade Connectors	1	278-316	Radio Shack	800-442-7224
43	Audio	Radio Shack 274-320 Mono Audio Adapters	1	274-320	Radio Shack	800-442-7221
44	Speech	Skutch AS-66 Telephone Line Simulator	1	SKUTCH AS-66	Skutch Electronics	916-786-6186
45	Speech	Plantronics CT10 Cordless Headset Telephone	1	CT10	Lyme Computer Systems	800-370-1095
46	Superview	RGB Spectrum Superview 1000-4	1	RGB 1000-4	Univisions Communication Group	800-836-0604
47	Superview	Ultraspec #1522 VGA to 5 BNC Cables	2	1522	Ultraspec Cables Inc.	800-622-2537

**APPENDIX C
SCHEDULE**

SCHEDULE

Wed 8/28/02 10:34 AM

PIDW Production Schedule

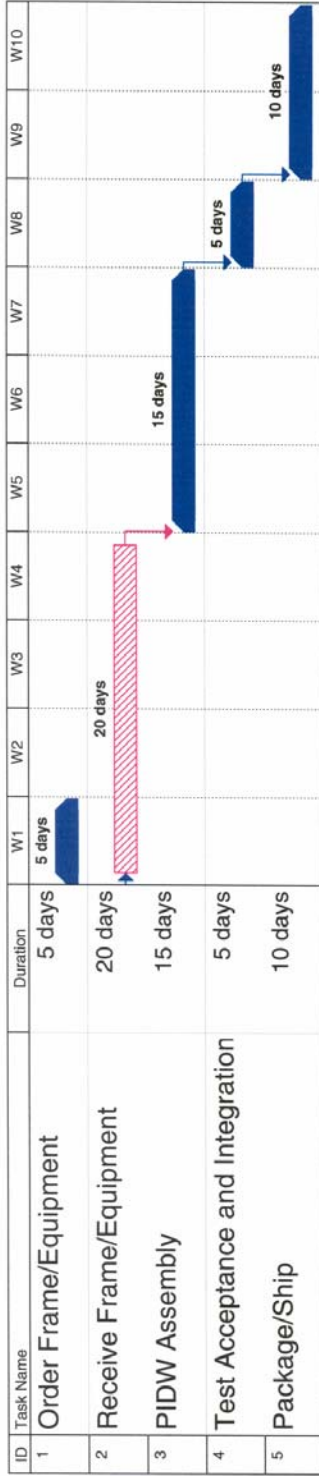

APPENDIX E – USER MANUAL SUPPLEMENTS

MAINTENANCE AND ADJUSTMENT ON THE PORTABLE INTERACTIVE DATAWALL (PIDW)

Projector Alignment

NOTE:

Be sure to tighten all adjustment screw locknuts before transport.

- The extrusion platforms that support the projectors and the adjustment wheels have been locked into place so there is no gap or overlap between the 3 projected images. It should not be necessary to adjust the projectors, however, if minor adjustments are required, follow the steps below.

Vertical Adjustment

- The vertical adjustment of the projected image can be adjusted by loosening the locknuts on the front projector foot with a 13mm open-end wrench and turning the thumbnut on the projector mount.

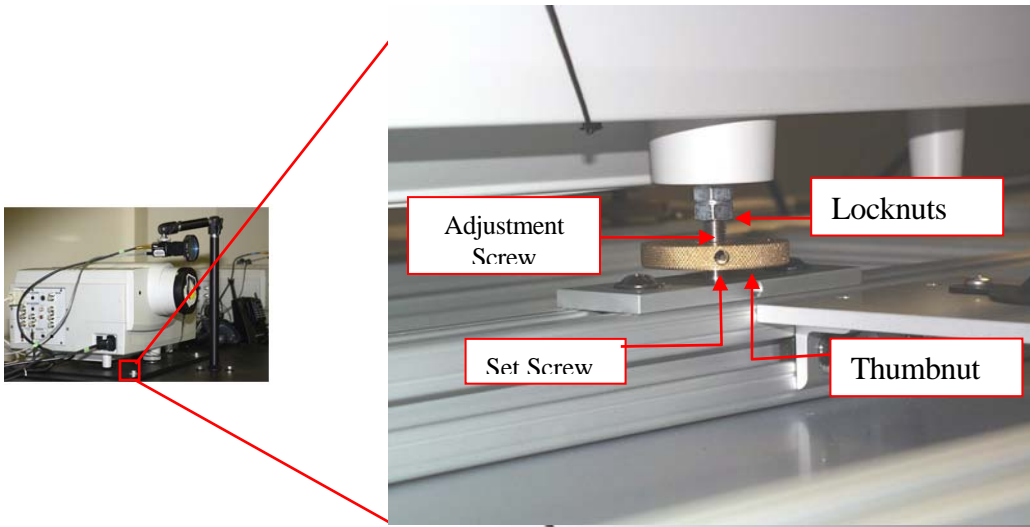

WARNING:

The thumbnut is secured to the adjustment screw by a set screw. Failure to loosen the set screw will prohibit the adjustment screw from turning freely. Forcing the thumbnut without loosening the set screw will result in the set screw damaging the adjustment screw. Loosen the set screw with the 3/32 hex wrench.

Tilt Adjustment

- The tilt adjustment of the projected image can be adjusted by loosening the locknuts on either of the two rear projector feet with an 8mm open end wrench and loosening the thumbnut.

WARNING:

The thumbnut is secured to the adjustment screw by a set screw. Failure to loosen the set screw will prohibit the adjustment screw from turning freely. Forcing the thumbnut without loosening the set screw will result in the set screw damaging the adjustment screw. Loosen the set screw with the 3/32 hex wrench.

Size Adjustment

- The size adjustment of the projected image can be adjusted by loosening the anchor fasteners that secure the projector platform to the cart.
- Using the 7/32 hex wrench, loosen the anchors on both sides of the extrusions at each of the four connection points.
- Slide the platform/projector closer to the screen for a smaller image, farther for a larger image.
- Tighten the anchors when the projector is in the desired location.

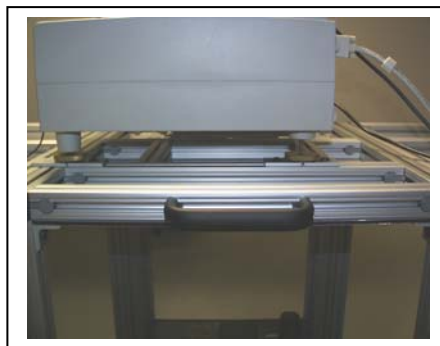
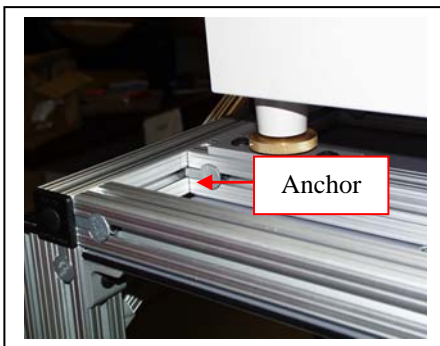

Left/Right Adjustment

- The projected image can be adjusted left or right by loosening the three projector plates that secure the projector to the extrusion platform.
- Loosen the plates with the 3/16 T-handle ball point hex tool.
- Slide the projector to the desired location.
- Tighten plates to secure.

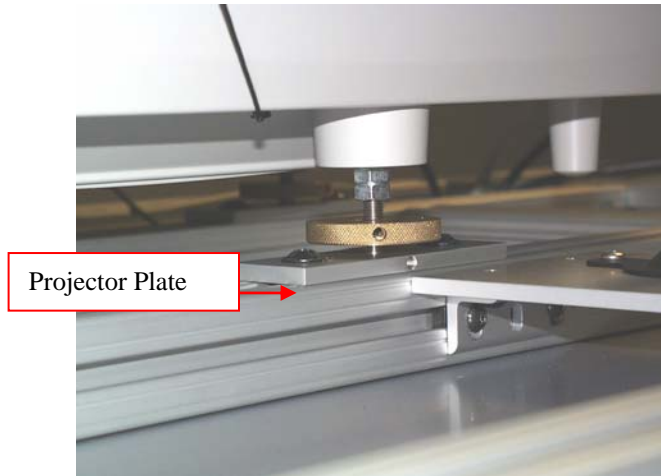

Projector Bulb Replacement or Air Filter Cleaning

NOTE:

Projector bulb replacement is covered in the manual for the projectors. Change the lamp module or clean air filter as per pages 48-50 or page 51 of the JVC-DLA S15 projector manual, respectively.

To remove projectors from the frame, simply loosen the set thumbnut set screw and carefully lift the projector off the frame.

RAISING AND LOWERING THE SCREEN OF THE PORTABLE INTERACTIVE DATAWALL (PIDW)

NOTE:

It is suggested that the screen be removed from the projection screen frame before lowering the frame.

1. Remove the frame from the lower arms loosening and removing the end cap from the lower arms. The end cap and frame mount should remain attached to the frame.



2. Retract the lower arms or remove them completely by sliding them out of the arm mounts (If the

screen is still attached, the arms should be removed).



3. Loosen the elbow mounts on the upper arms with the ratcheting L-handles.

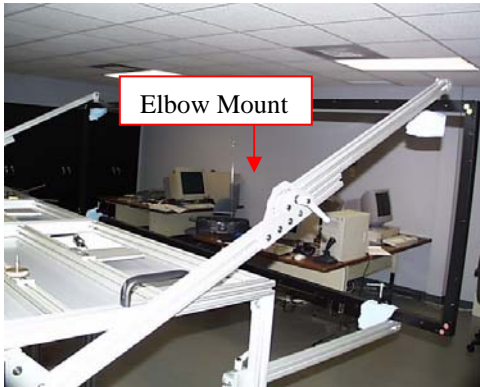

4. Carefully collapse the arms until the projection screen frame rests on the front of the PIDW frame.

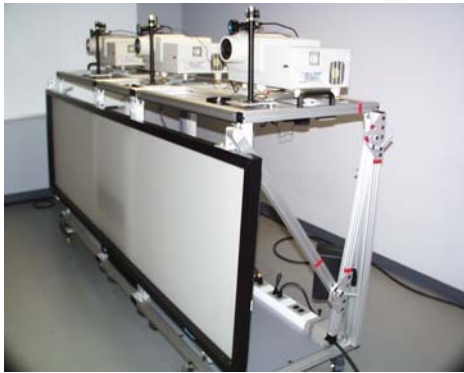

5. Secure into place by locking the L-handles.

Raising the Screen from the Folded Position

See Assembly Plan – See Projection Frame Installation