

new
2004B
AEC Category: HEALTH AND SAFETY

CEX-59.4

CIVIL EFFECTS STUDY

AERIAL RADIOLOGICAL MONITORING SYSTEM
Part III
ELECTRONIC PROCESSING OF ARMS-II DATA

J. E. Hand and H. M. Borella

DISTRIBUTION STATEMENT A
Approved for Public Release
Distribution Unlimited

20040407 540

Issuance Date: September 1965

CIVIL EFFECTS TEST OPERATIONS
U.S. ATOMIC ENERGY COMMISSION

LEGAL NOTICE

This report was prepared as an account of Government sponsored work. Neither the United States, nor the Commission, nor any person acting on behalf of the Commission:

A. Makes any warranty or representation, expressed or implied, with respect to the accuracy, completeness, or usefulness of the information contained in this report, or that the use of any information, apparatus, method, or process disclosed in this report may not infringe privately owned rights; or

B. Assumes any liabilities with respect to the use of, or for damages resulting from the use of any information, apparatus, method, or process disclosed in this report.

As used in the above, "person acting on behalf of the Commission" includes any employee or contractor of the Commission, or employee of such contractor, to the extent that such employee or contractor of the Commission, or employee of such contractor prepares, disseminates, or provides access to, any information pursuant to his employment or contract with the Commission, or his employment with such contractor.

Printed in USA. Price \$1.00. Available from the Clearinghouse for Federal Scientific and Technical Information, National Bureau of Standards, U. S. Department of Commerce, Springfield, Va.

AERIAL RADIOLOGICAL MONITORING SYSTEM

Part III ELECTRONIC PROCESSING OF ARMS-II DATA

By

J. E. Hand and H. M. Borella

Approved by: L. J. DEAL

Chief, Civil Effects Branch
Division of Biology and Medicine

Edgerton, Germeshausen & Grier, Inc.
Santa Barbara Laboratory

December 1962

NOTICE

This report is published in the interest of providing information which may prove of value to the reader in his study of effects data derived principally from nuclear weapons tests.

This document is based on information available at the time of preparation which may have subsequently been expanded and re-evaluated. Also, in preparing this report for publication, some classified material may have been removed. Users are cautioned to avoid interpretations and conclusions based on unknown or incomplete data.

ABSTRACT

A method of utilizing electronic data-processing techniques for the reduction and presentation of airborne terrestrial-radiation measurements is presented. The instrumentation used by the Aerial Radiological Measuring Survey (ARMS-II) was developed by Edgerton, Germeshausen & Grier, Inc. (EG&G), under sponsorship of the Division of Biology and Medicine, Civil Effects Test Operations, U. S. Atomic Energy Commission. Systematic surveys of terrestrial radiation occurring over large land areas are performed throughout the United States by EG&G personnel. A nominal-sized area entails some 10,000 traverse miles of flying with the acquisition of nearly 100,000 data points. As a consequence, manual reduction and presentation of the raw data are highly impractical. For rapid reduction and early availability of the data, it is necessary that modern electronic techniques be adapted to the processing of ARMS-II data.

The system described utilizes the IBM-704 electronic computer as the principal processing machine. Peripheral gear includes the following IBM equipment: 1401 computer, 407 lister, 047 tape-to-card converter, 523 summary punch, and 082 card sorter. An Electronics Associates, Inc., model 3200 Dataplotter with a 30- by 30-in. plotting surface is employed to present the finished data graphically.

Data are recorded in flight as binary entries onto punched tape. The data on the field tapes and the ground measurements necessary for computation are sent to the ARMS-II laboratory and converted to IBM card formats for entry into the computer. The data are taken to the computer center and processed; the computer provides the output information as a decimal tabulation of the radiation levels and their associated geocentric coordinates and converts the data to coordinates that are compatible with the X-Y plotter input requirements. The data positions and radiation levels are plotted as map overlays at 1 mile per inch scale, from which the final presentation form is prepared. The position data are accurate to 0.001° , with $\pm 9\%$ uncertainty present in the radiation levels.

ACKNOWLEDGMENTS

The authors take this opportunity to acknowledge the programming effort contributed by Jere A. Swanson, now with General Electric TEMPO, Santa Barbara, Calif. Successful machine manipulation of the aerial data was due quite strongly to his perseverance and basic understanding of the problem.

Our thanks are also extended to Donald Allison and Vern Weissman of EG&G for their extensive contributions in IBM-card generation, machine operations, and quadrant plotting. Their attention to flight notes and ground-data-card details gave considerable aid to the "debugging" process.

Special acknowledgment is given to the flight crew which collected both test and operational data during systems checkout. The crew consisted of R. B. Guillou, J. K. Thompson, E. Shultz, J. Gilliland, W. Verheyden, and R. Reskovic.

CONTENTS

ABSTRACT	5
ACKNOWLEDGMENTS	6
CHAPTER 1 PHYSICAL ASPECTS OF ARMS-II DATA PROCESSING	9
1.1 Introduction	9
1.2 Selection of a Processing Method for ARMS-II Data	9
1.2.1 Presurvey Planning	9
1.2.2 Map Measurements	10
1.2.3 Quantity of Data	11
1.2.4 Manual Data Handling and Presentation	11
1.2.5 Selection of the Computer and Data-entry Media	11
1.3 Processing Equipment and Data Flow	12
1.4 Flight Tactics and Field-data Editing	13
1.4.1 Flight-pattern Restrictions	15
1.4.2 Selection of Landmarks	15
1.4.3 Data-editing and Data-rejection Criteria	16
1.4.4 Flight and Field Notes	17
1.5 Effect of Operational Factors on Data	20
1.5.1 Data Identification	20
1.5.2 In-flight Doppler Operation	20
1.5.3 Flight-pattern Analyses	21
1.5.4 Effect of Magnetic Headings	21
1.5.5 Interpretation of Across-track Distance Error	23
1.6 Reduction of Position Data	23
1.6.1 Correction and Conversion Methods	23
1.6.2 Conversion of ARMS-II Data to Longitude and Latitude	24
1.6.3 Conversion of Longitudes and Latitudes to Rectangular Plotter Coordinates	28
1.6.4 Determination of Plotter-origin Coordinates	31
1.7 Accuracy Requirements of the Processing Method	32
CHAPTER 2 MACHINE MANIPULATIONS OF ARMS-II DATA	35
2.1 Introduction	35
2.2 Preparation and Formats of Input Data	36
2.2.1 Punched-paper-tape Format	36
2.2.2 Punching Cards from Paper Tape	37
2.2.3 Control-panel Functions	37
2.2.4 Arranging Data for a Computer Run	37
2.2.5 Checking of Input Data Before Processing	39
2.3 Performing the Computer Run	39
2.4 Reentry of Data	40

CONTENTS (Continued)

2.5	Machine Program	40
2.5.1	Scope of the Program	40
2.5.2	Program Structure and Machine Sequence	40
2.5.3	MAIN Program and Process Monitor	40
2.5.4	Subroutines	44
2.5.5	Instructions for Using LLIN	50
2.6	Data-plotting Operation	50
2.6.1	Plotter Description	50
2.6.2	Plotter Input Cards	51
2.6.3	Patch-board Wiring	51
2.7	Evaluation of the ARMS-II Automatic Data-plotting System	53
2.7.1	Test Results	53
2.7.2	Processing Time and Costs	53
2.8	Summary and Conclusions	54
APPENDIX	56

ILLUSTRATIONS

CHAPTER 1 PHYSICAL ASPECTS OF ARMS-II DATA PROCESSING		
1.1	Survey-area Layout	10
1.2	Data Flow	14
1.3	Field Map Measurements in Key-punch Format	18
1.4	Computer Compilation Reference on Raw-data Quality	19
1.5	True and Indicated Aircraft Flight Paths	22
1.6	True Flight Reference Line as Determined from Across-track Distances	26
1.7	Along-track and Across-track Distance Correlations to East-West and North-South Distances	28
CHAPTER 2 MACHINE MANIPULATIONS OF ARMS-II DATA		
2.1	Computer Input-card Sequence	37
2.2	Computer-program Structure	40
2.3	ARMS-II Computer-program and Data-processing Monitor	41
2.4	Example of On-line Monitor Diagnostic Print-out	45
2.5	Typical Plotter Input Card Showing the Card Location of Data	52
APPENDIX		
1	The 047 Tape-to-card Converter	56
2	The IBM 082 Card Sorter	57
3	The IBM 523 Summary Punch	57
4	Electronic Associates, Inc., Model 32 Dataplotter	57

TABLES

CHAPTER 1 PHYSICAL ASPECTS OF ARMS-II DATA PROCESSING		
1.1	Determination of True Azimuth Quadrant Between Checkpoints	26
1.2	Error Angle Quadrant Correction	27
1.3	X-Y Plotter Count Calibrations	30
1.4	Conversion Factors for 0.001° Latitude	33

Chapter 1

PHYSICAL ASPECTS OF ARMS-II DATA PROCESSING

1.1 INTRODUCTION

After nearly two years of survey activities, operational procedures for obtaining survey data have become more or less standardized. Based upon the experience gained from these activities and the necessity for automatically processing the collected data, a critical examination was made of Edgerton, Germeshausen & Grier, Inc. (EG&G), Report S-30, *An Automatic Data Handling and Presentation System for Use with the Aerial Radiological Monitoring System*,¹ to update the computational requirements and procedures described therein.

Since the corrected data are to be plotted on maps having a scale of 1 mile per inch, data points must be plotted accurately to $\frac{1}{16}$ in. Consequently the computational formulas must give results which provide longitudes and latitudes that are accurate to 0.001° . For this reason an attempt was made to adapt the method used by the United States Coastal and Geodetic Survey (USCGS) to ARMS-II requirements. The results, using reduced accuracy USCGS expressions, have been tabulated and are presented in the following sections along with the requirements in associated problem areas.

1.2 SELECTION OF A PROCESSING METHOD FOR ARMS-II DATA

A short description of the method and procedures followed during the collection and presentation of ARMS-II survey data is appropriate prior to a discussion of the proposed system of automatically processing the data. It is felt that three purposes will be served:

1. To acquaint the reader with the flight patterns used and the preflight and postflight map measurements required to supply necessary information to the computer
2. To create an awareness of the huge quantities of data generated during survey activities over a 100- by 100-mile area
3. To provide a description of the manual data-reduction and -presentation process against which the merits of the proposed automation scheme can be compared

1.2.1 Presurvey Planning

The particular section of interest in an assigned survey area serves as the focal point from which the survey boundaries are determined (excluding, of course, cases where terrain features dictate border geometry). A square, 100 miles on each side, is laid out on appropriate maps centered on the point of interest and oriented in the manner that is most compatible with terrain, population, and other pertinent features. Proposed flight lines are then laid out on 1 statute mile spacings from one edge of the area to the other; this gives a gridwork resembling that shown in Fig. 1.1.

The edges of the survey area may or may not be north-south and east-west lines. For the area diagrammed in Fig. 1.1, in the ideal case the aircraft would begin flying north at 500 ft above terrain on the eastmost line (north-south grid line). At the end of the line, a 180° left

turn would be executed and a traverse made southward on the next line. At the end of the second line, a 180° turn would be made to the right and the survey continued north on the third line. This procedure is continued over the entire area. As the aircraft travels along the flight lines, gamma radiation from the surface of the earth is detected and measured by the instrumentation carried in the plane. In order that the radiation data can be associated with its proper geographic location, the position of the aircraft is determined in flight by a Doppler navigation system that has been modified to permit digital recording of the position information. The Doppler apparatus is completely contained aboard the aircraft. A ground reference is used as a starting point, and during flight the position information is generated in relation

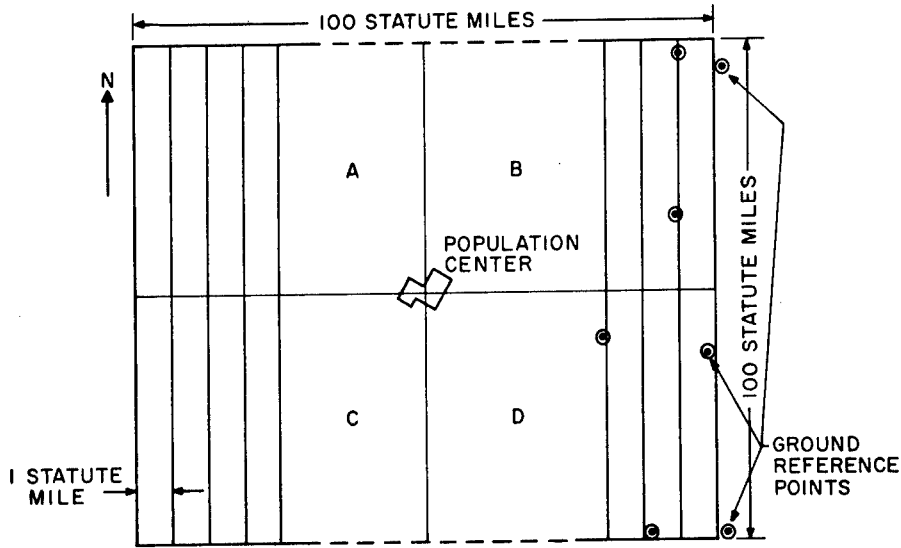

Fig. 1.1—Survey-area layout.

to this point and a reference course set into the compass system. When possible, the initial checkpoint is selected from area maps prior to flight. At the instant the aircraft passes over the checkpoint, the Doppler unit is activated; as the aircraft proceeds along course, the read-out mechanism gives a continuous indication of the distance traveled from the initial starting point in terms of along-track and across-track components. So that instrument errors accumulated during a traverse can be determined, each flight leg is closed over a known ground point. The closing point for a leg also serves as the initial point for the succeeding leg. In addition, as the aircraft progresses along a leg, ground points that are recognizable both from the air and on the maps are flown over and labeled on the maps as documentation points. These intermediate points serve to prevent re-flying an entire line in case of instrumentation failure during the traverse and also to keep the flight crew cognizant of their position along the leg.

Experience has shown that it is not always possible to determine points on a map beforehand which will be visible from the air. For example, road intersections that are clearly visible on a map may, in reality, be only two jeep trails that have since become obliterated, or landmarks on the maps in metropolitan regions may have become overrun with housing tracts, newly constructed freeways, etc. Consequently, the checkpoints are determined during flight and are immediately located and labeled on the flight maps to conserve preflight planning time and to prevent searching for a checkpoint during survey flight.

1.2.2 Map Measurements

During the postflight data editing, the checkpoints used are reexamined for proper line correlation and identification. For use of these points in the computation process, measurements are taken of their distance and direction across track from the preplanned flight line, and the longitude and latitude of the point are recorded. With these figures properly entered

into the computer, corrections are made for instrument errors at each data point, and the longitudes and latitudes are calculated for the points.

For a normal-sized survey area, 100 by 100 miles, an average of 4 checkpoints per 100-mile line is used, which gives a total of 400 checkpoints that require map measurements. If the terrain requires that short flight lines be used, additional points are needed.

1.2.3 Quantity of Data

Two modes of data print-out during flight are available: (1) a periodic, timed print-out occurring approximately every 3 sec and (2) an automatic print-out occurring whenever the radiation intensity changes by a preset incremental amount. In practice the former method is more commonly employed than the latter over regions of fairly constant radiation intensity, whereas in areas where radiation gradients are to be expected, or are exhibited, the latter is used. With each method, of course, the number of recorded data points differs. Over a long period of time in which combinations of both modes have been used, it has been found that an average of 10 to 11 data points are recorded per mile of traverse. In terms of a full-sized survey area, a total of some 100,000 data points is to be expected, with each recorded entry representing six pieces of information. To correct, plot, and calculate the coordinates of each point manually would be impractical.

1.2.4 Manual Data Handling and Presentation

During the first year of survey operations, procedures for manually compiling and presenting the data were employed. Although all the recorded data points were examined, only those pertinent to a change in aircraft flight direction or a significant change in radiation intensity were plotted. Corrections to each plotted data point for the instrument error were performed by graphical methods, and the corrected locations of each point were plotted on United States Geological Survey (USGS) 1:250,000 map overlays. Radiation values were entered at each point plotted so that regions of similar radiation intensity could be delineated into groups (called aeroradioactivity units). From the overlay and base-map materials, final maps were constructed which showed the radioactivity units superimposed over a subdued background of the survey area.

Although the process described meets the data-presentation requirements, it is clear that full advantage is not taken of the ground resolution inherent in the aircraft-positioning apparatus. To take full advantage means that each data point should be plotted on either 1:24,000 or 1:62,500 scale maps, a task that is unbearably time consuming if done manually. For determination of the time required for plotting on the large scales experimentally, all the data points within a typical 1:62,500 quadrangle were plotted manually in raw-data form. The time required was two full man-days, and, since a normal survey area contains about 40 such maps, the manual effort required for 1:62,500 scale plotting becomes clear. With computer processing of the data and high-quality X-Y recorder plotting, all the data can be corrected and plotted in less than eight days on 1:62,500 scale maps.

It is planned to provide the output data from the automatic processing system in three forms:

1. A 1:62,500 scale plot with the radiation level recorded at each data point
2. Tabulation of each data point in terms of longitude, latitude, and radiation level
3. A 1:250,000 scale map of the aeroradioactivity units

It is felt that, if the data are available in these finished forms, they will be universally applicable to any particular need.

1.2.5 Selection of the Computer and Data-entry Media

Considerable discussion and exchange of ideas have transpired between members of the ARMS-II group and people actively engaged in the data-processing field with regard to the relative merits of the type of processing, data entry, storage media, and components toward which the system should be directed. The advantages and disadvantages of card systems,

punched-tape systems, and magnetic-tape systems have been considered as well as the type of computer and peripheral equipment required in each case.

The type of media used for storage, transport, and entry of the data during machine operations is governed quite largely by the type of computer required to perform the calculations. The extent of the instructional entries, quantity of data points, and storage required for the calculations excluded the IBM-1620 computer, although it is an attractive machine from data-entry standpoint because it accepts either punched-tape or card inputs. Excessive time would have been involved in processing the data from an entire survey since relatively few points could have been processed during a single run.

Consequently considerations were directed toward the IBM-704. Although the functions and manipulations the machine must perform on the data are not complex, the large quantity of data to be handled demands a computer with large storage and rapid calculating capabilities.

Data are read in and out of the IBM-704 by magnetic tapes. Consequently the data must be converted from punched tape to magnetic tape for machine acceptance. In addition, the magnetic-tape output pointed to the possibility of utilizing a plotter with a magnetic-tape input. An investigation of the prices associated with magnetic-tape reading and input devices quickly discounted further considerations of these units. Moreover, the lease cost of a punched-tape to magnetic-tape converter, which would be used to prepare the raw data for machine entry, is extremely high. The raw-data tapes from the aircraft could be converted to magnetic tape at a computer center, but the measured values of map distances and coordinates must also be entered into the computer input media. For simplicity and convenience, it is much more desirable to perform this task at the ARMS-II laboratory.

Cards appear to be ideally suited to the task since IBM key-punch units are readily available and reasonably priced on lease; in addition to permanence of the data entries, cards also provide an advantage that is absent in the magnetic-tape converters. With the keyboard and printer option, preflight and postflight data can be easily entered on cards and immediately monitored for the correctness of the entry. In addition, the punched tape can be converted to cards by automatic operation of the key punch. The cost of such a unit placed in the laboratory is \$165 per month.

In summary, IBM cards were selected over magnetic tape as data-entry media for the following reasons:

1. Data are permanent.
2. Card-reading, -handling, and -punching equipment is more reasonably priced than equivalent magnetic-tape equipment.
3. Visual monitoring of manual entries can be readily performed.
4. Sections of data can be selected without searching through the entire library.

The main disadvantage related to card use is the storage required for the large numbers of cards generated in entering the data from an entire survey. The cards are relatively inexpensive (\$13 per 10,000), and, since card-handling equipment is readily available, both on lease and at computer processing centers, the many advantages of using cards outweigh the aforementioned disadvantage.

Punched-tape systems were dropped from consideration early in the investigation for several reasons. Although nearly all data-processing centers have punched-tape to magnetic-tape conversion equipment, some do not have the capability of converting the computer output magnetic tape to punched tape. Although the punched-tape system is the most economical and convenient method to record data in flight, the problems associated with handling, reading, and manual data entry onto punched tape justify the selection of other data-recording media for machine-processing work.

1.3 PROCESSING EQUIPMENT AND DATA FLOW

The basic unit and data-entry media for the ARMS-II automatic processing system is the IBM-704 computer and IBM cards. The proposed data-flow process is illustrated in Fig. 1.2 and can be described as follows:

1. The raw-data tape from the aircraft and all map measured data are entered on IBM cards at the ARMS-II laboratory with an IBM-047 key punch.
2. The set of cards generated is taken to a computer center and entered into an IBM-card to magnetic-tape converter unit. This unit is generally a part of an IBM-1401 computer, which is much smaller than the IBM-704 and less expensive to use. Cards are entered on the machine to put the data into acceptable form for the IBM-704.
3. The magnetic tape generated by the IBM-1401 computer is taken to the IBM-704 and serves as the input data source.
4. The data and programming are entered into the IBM-704 computer, which performs the necessary manipulations and conversions on the positioning and radiation data. The reduced data are reentered on magnetic tapes.
5. The output magnetic tapes are again taken to the IBM-1401 computer and the data entered on a new set of cards. At this time the data are also fed into a printer, and a decimal tabulation is made in terms of longitude, latitude, radiation channel number, leg number, and survey-area identification for each data point. The data entered on the cards are in terms of coordinates which are equivalent to longitude, latitude, and radiation channel and which are in units acceptable to the plotter.
6. The magnetic tape, decimal tabulation, and cards are returned to the ARMS-II laboratory. The cards are entered into an IBM-523 summary punch, which reads the card data and generates the input signals to the X-Y plotter. The magnetic tape is stored in a controlled-environment room and the decimal tabulation entered into the ARMS-II library for future use as reference. If requested, reproduction of the decimal listing can easily be obtained.
7. For the most part the plotting is done on a scale of 1 : 62,500 of all the data points on a transparent overlay material. Aeroradioactivity units are constructed on this base map. The final product is then obtained by photographic reduction of the overlays to a scale of 1 : 250,000.
8. The plotter has the capability of plotting directly on maps of several scales, i.e., 1 : 1,000,000, 1 : 500,000, and 1 : 250,000 as well as the larger scales 1 : 62,500 and 1 : 24,000.
9. The cards are sorted with an IBM sorter into stacks containing the coordinates that appear within the 30-in. boundary of the plotter prior to the plotting operation to ensure that the X-Y plotter loses no time in attempting to locate points off the plotting surface.

*Too slow to be used
 (not used)
 removed from
 ARMS-II
 plotting
 factor*

The system described will permit all work except the computer reduction of the data to be performed at the ARMS-II laboratory. This feature permits retaining the desired degree of control on the final product.

The computer program has been constructed in a FORTRAN code (Formula Translator), which ensures its versatility for use in other computers (such as the IBM-709 and 7090) if an IBM-704 is not available at the time data are required. Since the popularity of these machines has created a large inventory, the project is not tied to any one computer or location for processing ARMS-II data.

The use of FORTRAN language for the computer program has other advantages. Changes and debugging are easily accomplished since the program is written in the form of several subroutines, each subroutine being logically independent from the others. This breaks the program down into separate units. Each unit may be revised individually, and, if a change is necessary, only the subroutines in which it occurs need to be recompiled.

1.4 FLIGHT TACTICS AND FIELD-DATA EDITING

The foregoing discussion has presented an overall picture of the field-data-collection techniques, the automatic data-processing procedure, and the compilation of the final maps and data tabulations. We shall now take a more detailed look at the sequence of events that is necessary to collect raw field data and convert it into the final products.

The modified Doppler navigation system on the aircraft supplies position information with respect to known landmarks by placing coded punches in paper tape. The Doppler data represent the position of the aircraft in terms of the projection of the flight path along a reference line and the perpendicular distance away from the reference line.

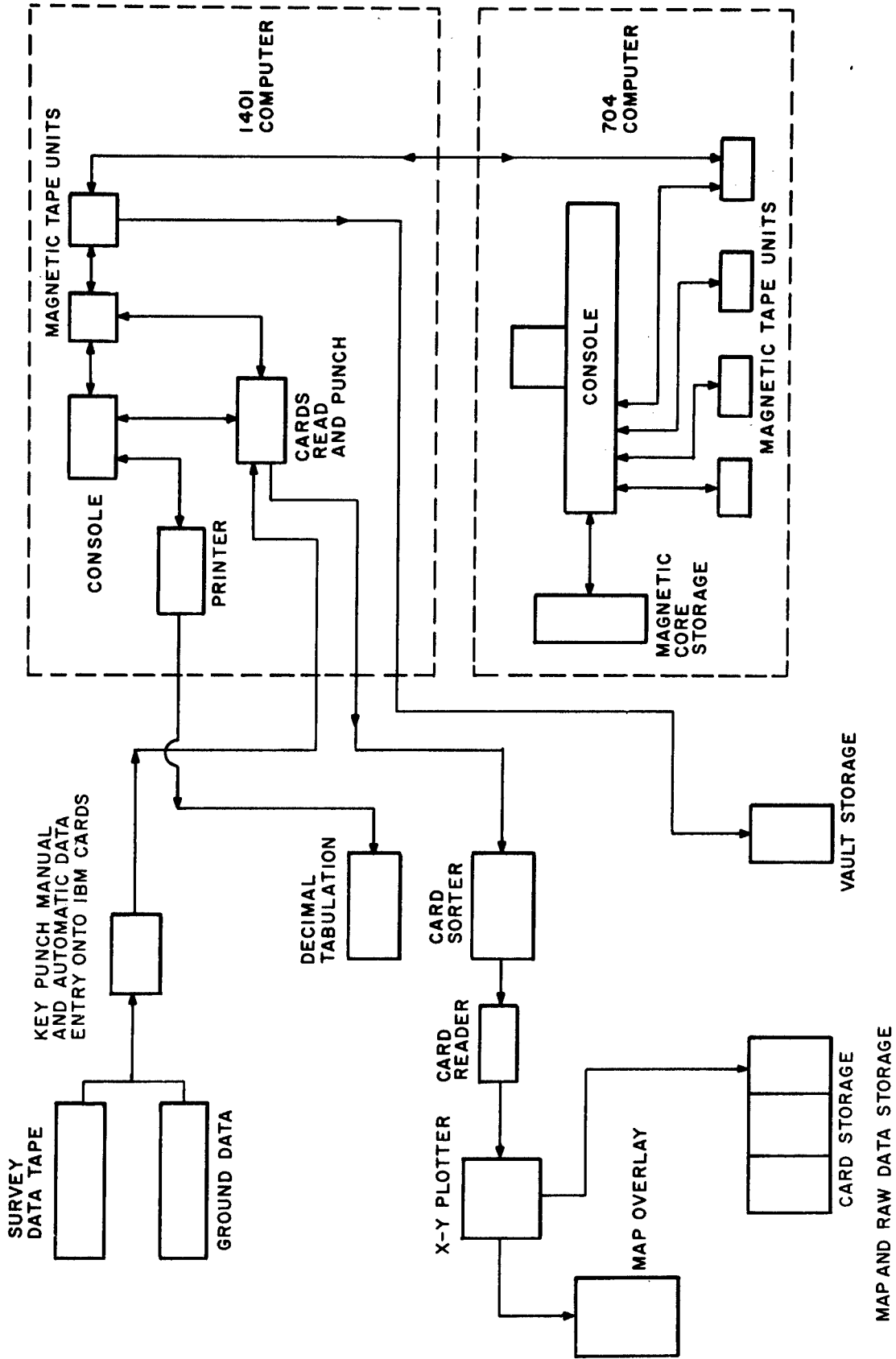

Fig. 1.2—Data flow.

Position data are recorded during flight simultaneously with radiation channel, sensitivity level, and leg number. A change in leg number marks the end of a data group and re-setting of the Doppler system.

1.4.1 Flight-pattern Restrictions

Automatic processing requires that the information recorded be consistent and free from error. The errors exhibited by the Doppler navigation system are, for the most part, traverse closure errors, although experience has indicated that equipment failures and improper flight procedures frequently produce erroneous and sometimes useless portions of data. Observation over a period of time has resulted in a classification of the most common types of errors that can be recognized by machine logic and removed automatically. Standardized flight procedures have been adopted which are designed to minimize the quantity of unusable data entered on the punched tape.

For maximum system utility per aircraft flight hour to be obtained, the computer program must place as few restrictions on survey-flight tactics as possible. Of course, the computer has certain limitations, and caution must be exercised in executing the survey flights so that data, which may be valid, do not appear to be ambiguous to the computer and cause the machine to stop during a process run. Therefore, to approach maximum utilization of the aircraft and detection apparatus, the computer program has been prepared so that no restrictions are placed on the flight pattern. The ground track generated by the aircraft during normal data collection forms a systematic groundwork of parallel lines. But, if topographic features of the terrain dictate that closed loops or figure-8 paths are necessary to obtain the aerial data, the computer program does not prohibit the pilot from doing so. It is necessary only for a crew member to record the proper quantities in the flight notes.

The accurate delineation of ground checkpoints on the flight maps is extremely important since the measured values of longitudes and latitudes of these points are used in the calculations for the geocentric coordinates of the intermediate data points. The instructions to crew members continually emphasize the importance of correct map correlations with topographic features used for Doppler transfer (leg end points) and intermediate documentation points.

1.4.2 Selection of Landmarks

In-flight selection of landmarks, compilation of the flight notes, and postflight data-editing procedures are governed by the following criteria.

The computer recognizes an end-of-data group by either of two entries: a change in survey leg number or an entry consisting entirely of zeros. The latter is used for the documenting of ground points which are definitely identifiable and which lie between the survey-leg end points. A data print-command signal is generated manually over the ground point; the entry immediately follows the zero entry. (This procedure has been found to be more convenient than transferring Doppler readers at these points because of several limitations in the Doppler apparatus.)

In general, the leg number is changed over a known ground location at the end of a traverse line when it is necessary that the aircraft fly a new course to continue the survey. In this case, the navigator manually demands a print-out over the point. The recorded data consist of the new leg number and the old leg traverse closure values. The computer recognizes either of the preceding types of entry as an end-of-data group. Consequently it is important that flight personnel keep close surveillance of landmarks and accurate entries in the flight notes.

At the end of a normal leg, if there is a good checkpoint on the line as well as another on the next line, the Doppler reader is transferred over the most discernible of the two. The navigator either transfers over the first and uses the second for visual reference only or uses the first for visual reference and transfers over the second. Documentation points closer than 15 miles are avoided.

This procedure is desirable in several respects. First, two checkpoints closer than this accomplish very little and unnecessarily complicate the data. Second, effort is saved in the airplane by the minimizing of documentation procedures. Third, fewer map measurements are required on the ground.

Closed loops, except in the execution of a turn at the end of a leg, require at least one checkpoint, preferably near the outermost point of the loop. If this is not possible, the true course is entered in the flight notes.

Closed loops at the end of a leg are rejected by the computer program. When the navigator intentionally flies a closed loop to obtain data, that loop does not form the last, or final, segment of the leg. That is, the loop segment is started with a new leg number, and precautions are taken to ensure that one more documentation point is recorded prior to the insertion of a new leg number.

1.4.3 Data-editing and Data-rejection Criteria

As mentioned earlier, experience has shown that it is not always possible to avoid recording sizable quantities of useless data. For instance, if the aircraft is proceeding along line in the normal fashion and the Doppler instrumentation detects a confusing return signal from some irregular terrain feature, the unit goes into a memory state. Generally this event will occur unexpectedly and never in the vicinity of a usable ground checkpoint. As a result, traverse closure information, which must be used for applying corrections to the data, is not available for the data entries up to the point of equipment malfunction. In cases of this sort, the line is reflight from the last recorded documentation point. The computer must recognize data of this nature and discard it in favor of the reflight, completed leg data. Since the computer must be programmed to recognize erroneous entries which can arise from several causes, in-flight procedures and postflight editing must be patterned after the computer requirements so that compatibility exists between the collected data and the computer capability. The following tabulation of data-rejection criteria by the computer is based on the most commonly occurring equipment and instrumentation malfunctions:

1. Unintentional zero entries except when the entire entry is zero. If either the along-track or across-track entries are zero, but not both, the observation is rejected.
2. Logic encoder wheels locked by too rapid generations of print commands. When the sum of the changes of along-track and across-track entries of two consecutive data points does not fall within some minimum value, A, and a maximum value, B, then the second entry is rejected unless the sum of the changes between the second and a third consecutive entry fall within the stated bounds, A and B.
3. Doppler system in memory or standby condition (also parity lockup). If three consecutive along-track and across-track values are equal, all data from the last documentation point up to a change in leg number are rejected. If the last documentation point happens to be the initial point, the entire leg is thrown out. At this point the computer again reads and handles data normally.

The binary punch contains a parity check position. If this circuit detects an erroneous entry on the tape as compared to the input signal, the perforator circuits will not accept new input information until they are manually reset. During this time consecutive entries of nines are punched in the tape and must be eliminated.

4. Initial Doppler entry. All data from the beginning of a leg until an along-track value of 10.00 ± 1.0 is found are rejected. The range of the Doppler reader is from 00.00 to 99.99 miles, but continuous recording is enacted in progressing past the 99.99 position and vice versa. For example, if terrain and the availability of checkpoints dictate that the pilot must fly a reverse course up a valley for 8 to 10 miles, return, and continue on line for a long traverse, it is clear that the Doppler could record identical mileage values in the nineties for two widely spaced locations if an indication of 00.00 mile were initially set in the Doppler. A value of 10.00 miles is always set in the Doppler readers at the initial checkpoints to avoid entries of this nature and the resultant possibility of confusion in ground-data editing and ambiguities in the data for the computations.

5. Erroneous across-track entries. The most commonly occurring misprint is wrong across-track direction, i.e., an L (left) for an R (right). Whenever an across-track direction (R or L) is different from both across-track directions immediately preceding and following it, the entire entry is thrown out.

6. Erroneous radiation-channel entries. If the change in radiation channels of two consecutive entries is greater than four and the third entry is not within ± 1 channel of the second, the second entry is rejected.

In the editing of data for computer processing, the most important considerations are associated with items 3 and 4. Items 1, 2, 5, and 6 are not as important from the editing standpoint since they reject only one point at a time.

In item 4, if no value between 9 and 11 is present, the entire leg will be rejected. Furthermore, if this value does not occur between the initial point and the first checkpoint, the computer will be confused, and an error will result; hence the operator must be certain a value occurs within these bounds.

For item 3, the operator must be sure that three equal entries are not accidentally included in the data. Conversely, to discard a leg for any reason, the operator must ascertain that the data contain three consecutive position entries which are identical. A new leg number is inserted at the beginning of new, good data.

1.4.4 Flight and Field Notes

The data under which item 3 is utilized are mentioned in the flight notes. Likewise all legs that are flown uneventfully are so indicated in the flight notes.

Flight notes are kept in an orderly, systematic manner (Figs. 1.3 and 1.4). An entry is made of the line number, taken from the area operational planning map, with the general flight direction, the leg number, and remarks on the quality or otherwise pertinent facts regarding the data of the leg. The slightest variation from standard flight practice is entered on this form.

It should be mentioned that any leg number that has less than 15 data-point observations associated with it is discarded. Situations arise in the air in which meaningless data are entered on the binary tape. These entries are generally introduced during presurvey warmup and checkout of the gear and during times when in-flight component malfunctions are being investigated. Rejection of these entries does not generate regional voids in the survey data because these voids generally occur before the area is reached. If a data void occurs over the survey area, the line is reflight.

During postflight editing of the data, map measurements are made of the longitude and latitude of the checkpoints used during the flight. The across-track distance and the direction of the leg initial point are also recorded. Figure 1.3 shows the format for these data. The form used is a standard data-processing form that is immediately recognizable to any key-punch operator. For instance, the entries indicate the following:

1. Area location and area region (Portsmouth, Ohio, Region A)
2. Date of data collection
3. Leg No. (388)
4. Three ground checkpoints
5. Across-track parameters of the initial point (0.20 nautical mile to the left of the desired or preplanned flight line)
6. Longitude of initial point (84.043°)
7. Latitude of initial point (38.997°)
8. Longitude of first documentation point (83.536°)
9. Latitude of first documentation point (38.996°)
10. Longitude of leg 388 end point (83.020)
11. Latitude of leg 388 end point (38.997)
12. Area and map line number (Portsmouth; 64E)
13. Date
14. Repetition of same information for leg 389

The forms shown in Figs. 1.3 and 1.4 are completed in the field by the data analyst and are sent to the ARMS-II computer laboratory along with the binary tapes that contain the recorded data indicated on the field compilation forms. In this manner, a minimum amount of time is lost by personnel at the laboratory in handling and interpreting the quality of the data. Data

LOCATION PORTSMOUTH, OHIO
 AREA A

PAGE 1081
 DATE 10-15-62
 INITIAL V.F.W.

LEG	N.P.										INITIAL XT																												
LONGITUDE										LATITUDE																													
LOCATION										DATE																													
1	2	3	4	5	6	7	8	9	10	1	2	3	4	5	6	7	8	9	10	1	2	3	4	5	6	7	8	9	10	1	2	3	4	5	6				
388										03																				-	0	.	2	0					
84.043										38.997																													
83.536										38.996																													
83.020										38.997																													
PORTSMOUTH										64-E									OCT.	15	1962																		
389										03																			1	.	2	0							
83.020										38.997																													
83.428										38.980																													
84.077										38.972																													
PORTSMOUTH										63-W									OCT.	15	1962																		
390										03																			-	0	.	6	0						
84.077										38.972																													
83.659										38.966																													
83.022										38.956																													
PORTSMOUTH										62-E									OCT.	15	1962																		
391										03																			0	.	4	5							
83.022										38.956																													
83.627										38.952																													
83.979										38.943																													
PORTSMOUTH										61-W									OCT.	15	1962																		
392										03																			-	0	.	7	0						
83.979										38.943																													
83.574										38.934																													
83.023										38.931																													
PORTSMOUTH										60-E									OCT.	15	1962																		
393										02																			0	.	7	8							
83.023										38.931																													
83.574										38.920																													
PORTSMOUTH										59-W									OCT	15	1962																		

Fig. 1.3—Field map measurements in key-punch format.

corrections, insertions, or deletions are indicated by the flight notes so that map correlations for unusable data need not be repeated. When returned from the field, the data are immediately ready for processing, and indications of the necessary action by laboratory personnel are shown in the Computer Compilation Reference form (Fig. 1.4).

1.5 EFFECT OF OPERATIONAL FACTORS ON DATA

1.5.1 Data Identification

Figure 1.1 illustrates the type of preoperation planning map used by ARMS-II personnel. The regions are labeled A, B, C, and D so that the general area of survey activities can be easily identified. Region boundaries are determined largely by terrain features. Checkpoints are shown along, and at the end of, the 1-mile spaced lines of the survey area. These points, indicating the existence of clearly definable ground features, are used during the systematic coverage of the area as traverse beginning and ending points and as intermediate documentation points. The distance between points ranges from 25 to 50 miles. The line between the beginning and the end checkpoint is called a "leg" and is identified by a leg number. The leg number is recorded in flight simultaneously with each data print-out. The legs are numbered consecutively from the beginning to the end of the survey area. Hence associated with each leg number is a unique set of beginning and ending checkpoints and their corresponding geocentric coordinates.

1.5.2 In-flight Doppler Operation

As the aircraft flies over the initial checkpoint, the Doppler navigation system begins to record the aircraft position in terms of along-track and across-track distances relative to the leg initial checkpoint and the predetermined heading. The Doppler navigation system makes use of a readout panel (reader) that contains two identical sets of indicators and controls. Predetermined distance and heading information may be inserted into both of these readers. When the system is in operation, one or the other, but not both, of the readers is in operation. The procedure followed during survey flights is as follows:

1. With both readers in the standby condition, heading, distance, and along-track and across-track information are manually set into one of the readers prior to the aircraft's flying over the leg initial checkpoint.
2. As the aircraft passes over the initial checkpoint, the Doppler system is activated by switching the reader used in item 1 from standby to run; the other reader remains in standby.
3. As the aircraft proceeds along the leg, distance and heading information for the next leg are set into the unused (alternate) reader.
4. When the aircraft reaches the end checkpoint, the alternate reader is switched on, and the first reader becomes inoperative and returns to the standby condition.
5. The next leg information is set into the standby reader and the process is repeated.

For the simplification of operation of the Doppler equipment during flight, the Doppler reader is switched only at the end of one of the area or region lines. Upon arriving at this position, the aircraft must make a 180° turn to proceed along the next line. Consequently the heading set into the second Doppler reader is different from that set in the first reader by approximately 180°. Since the flight program calls for parallel lines, it is clear that, once the proper headings have been entered into each reader, it is only necessary for the navigator to depress the Doppler reader transfer switch at leg endings for the survey to progress from line to line. Survey legs have ranged up to 90 miles in length during past operations. This distance, though desirable from the standpoint of obtaining efficient and rapid area coverage, introduces the need for recording intermediate tie-down or closure points along the leg. If landmarks are located, e.g., at 30 and 60 miles along the leg, which are suitable for map position correlations, it is desirable to document them so that the data collected along the leg to the last recorded landmark are preserved in case of equipment malfunction. The Doppler reader could be transferred at a documentation point, but this would necessitate resetting the heading in the alternate reader. Normal transfer at the leg end point would require another heading insertion.

Hence, in an attempt to minimize the operational effort required of the navigator and reduce the possibility of confusion, a simplified procedure is followed to accomplish the recording of a documentation point. As the aircraft approaches a point that is to be documented, the navigator introduces a complete zero entry on the data tapes. When the aircraft is directly over the point, he generates a manual print-command signal, and the aircraft-position information is recorded. A description of the point is entered in the flight notes, and the point is circled on the flight map. During postflight editing of the data, the geocentric coordinates of the point are measured and recorded for entry into the computer.

The computer is programmed to recognize the entry immediately following a zero entry as an end-of-data group; the machine also interprets a leg number change in the same manner. All data collected during each segment are then processed as an independent group of measurements, and the computations follow through to the final values for the longitude and latitude of each data point retained along the segment.

1.5.3 Flight-pattern Analyses

Figure 1.5 shows diagrammatically the problem to be solved by the computer. An area is depicted showing generalized proposed flight lines running northeast and southwest. Two ground checkpoints, labeled XO,YO and XN,YN, are entered in the proximity of one of the proposed lines. The point XO,YO represents the initial leg checkpoint, whereas the XN,YN can be either a documentation point or the leg end point. The aircraft proceeds to fly over the point XO,YO, at which point the Doppler reader is transferred to the unit that contains information pertaining to line 32N. Upon passing over the checkpoint, the pilot flies the aircraft into position along the proposed flight line by obtaining a zero indication on the across-track visual display of the Doppler system and flies along this line by monitoring a zero indication on the across-track distance indicator. When the navigator alerts him of the approaching end or documentation point with instructions as to its anticipated direction and distance from their location, the pilot swings the aircraft toward the point, and, as the aircraft passes over the point, the navigator causes position and radiation information to be recorded. The pilot then either swings back and continues on line or else makes a 180° turn and proceeds down the next line, depending on whether the point was a documentation or an end point. In either case traverse closing information was recorded over the selected landmark.

The computer must accept the data that were recorded along the flight path between initial and end points, examine the quality of the information, correct the position values for instrument and induced error, convert the resultant values to longitude and latitude, associate these figures with the correct radiation-level value, and convert the position information into coordinates that are compatible as an input to an X-Y plotter.

1.5.4 Effect of Magnetic Headings

The functions performed by the computer in determining the quality of the data have been described. Further details of these functions will be listed in Chap. 2. For the present, an examination of position correction and conversion procedures will be described. Figure 1.5 shows both an indicated and a true flight path. The angle γ is the azimuth from true north of the preplanned flight lines, α is the azimuth of the line directly connecting the two end checkpoints, and DCJ is the distance of this line. The effect of heading errors is contained in the angle β .

The angle $(\alpha + \beta)$ represents the true azimuth or flight reference line with which the data were taken. The navigator sets into the Doppler readers the headings of the preplanned lines, γ . These headings are then flown according to the indication exhibited by a J-4 compass system. The actual values set into the readers and by which the pilot must fly are magnetic headings. Although magnetic-heading information can be set into the Doppler readers to $\frac{1}{4}^\circ$, magnetic-course values do not coincide with true-course values by an amount equal to the magnetic declination prevalent in the region being flown. Information listing the magnitude of the declination is not readily available from sources other than aeronautical charts, and, for the United States, this information is provided as magnetic-correction lines superimposed on the aero-

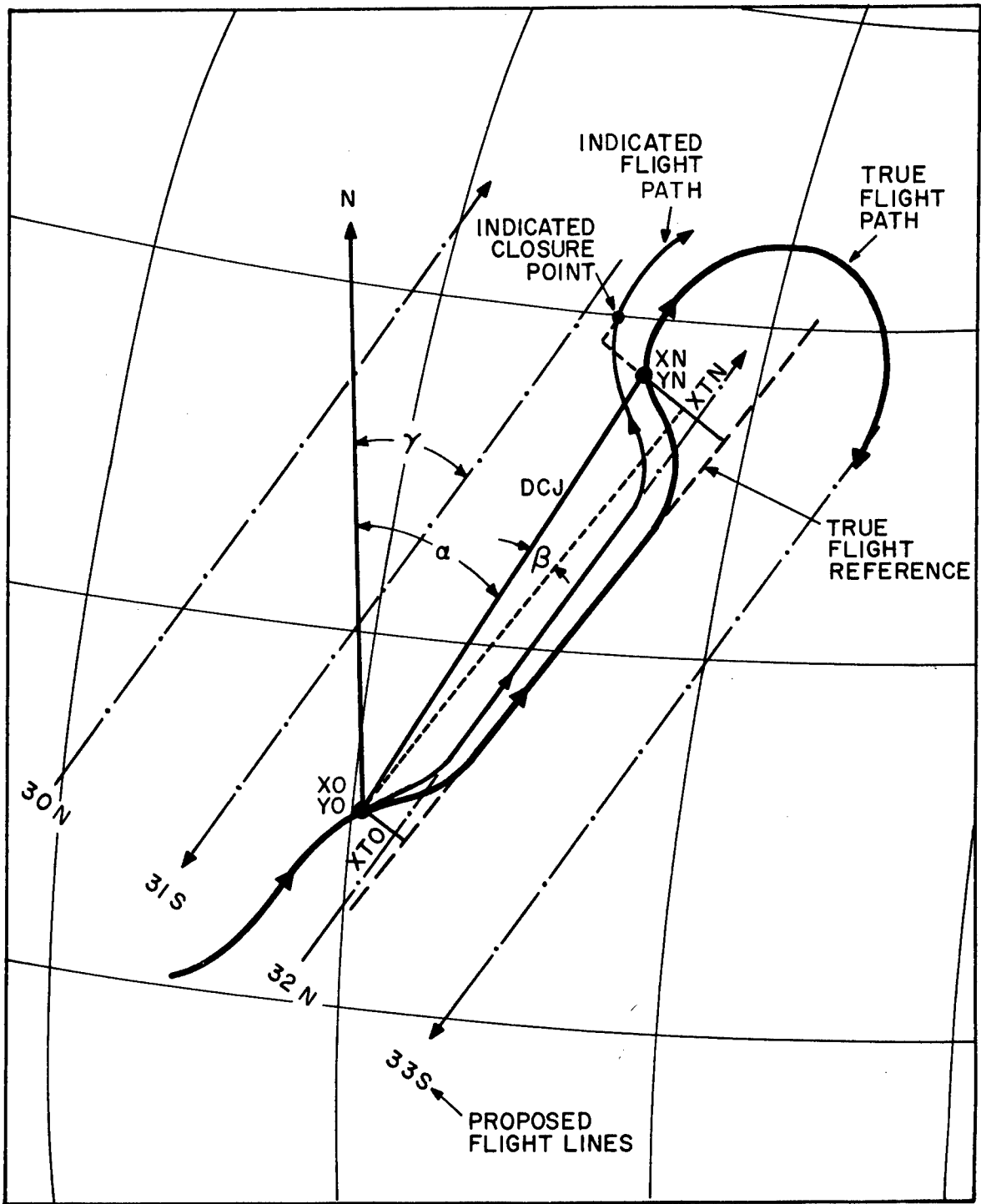

Fig. 1.5—True and indicated aircraft flight paths.

nautical maps. The intensity lines are drawn for every 30 sec of magnetic correction, which means that the values existing over intermediate regions must be interpolated. In addition, data describing diurnal variations, local perturbations, and long-term drift effects on the magnetic declination are not available for particular survey localities. Consequently it is almost impossible for the navigator to enter a value for the magnetic course that will result in zero error in the position data. The along-track and across-track decoding instrumentation contains inherent errors, particularly in the rate servo circuitry. The effect of the rate servo error can be nulled by adjusting the control potentiometers, but, during flight activities on line, temperature variations in the component boxes become visible by incorrect along-track and across-track distance indications as compared to map values.

The result of these combined effects is that the true position of the aircraft does not coincide with the position indicated on the instruments. Under the best conditions the discrepancy is small, perhaps on the order of 0.1-mile-radius circle of error in an along-track distance of 80 miles; the error is generally larger than this, depending almost entirely upon the magnetic headings entered into the Doppler readers.

1.5.5 Interpretation of Across-track Distance Error

When plotted, data collected under the described operating procedures will generally be displaced on the map from their known locations of collection. A plot of the Doppler position points will give a trace of the indicated flight path shown in Fig. 1.5. Since the navigator has attempted to set in the azimuth γ , the data would be plotted with respect to this angle. The figure shows that the indicated closure point does not coincide with the true point on the map. When data are handled manually, each point along the indicated flight path is proportionately corrected by graphic methods according to the indicated along-track position and magnitude of the closing errors. In light of the previous discussion and by inference from the relation of the true and indicated flight paths shown in Fig. 1.5, it is clear that the across-track error accumulation can be interpreted as an angular rotation of the flight reference line. The magnitude of the rotation is contained in the angle β ; hence the dashed line in Fig. 1.5 labeled "true flight reference" represents the actual reference line against which the Doppler system has provided data. All the across-track distance measurements represent values that are perpendicular to this line. For instance, if the information on the raw-data tapes were plotted with respect to the true flight reference line, the indicated values would coincide with the true flight path shown.

A method of handling the data was needed which would be compatible with machine processing and yet contain sufficient generality to take into account all imaginable survey flight patterns. An investigation was therefore made of the procedures that could be followed to correct the data points mathematically. The basic assumption utilized is that in all cases error accumulation is a linear function with time. As far as the instrument contribution to the total error is concerned, the assumption is valid. It is, perhaps, questionable over areas in which magnetic anomalies occur in the earth's magnetic field. Keeping the distance between documentation points small, i.e., between 30 and 50 miles, provides an assist in minimizing the effect of nonlinear error contributions.

1.6 REDUCTION OF POSITION DATA

1.6.1 Correction and Conversion Methods

A direct method of calculation, which computed the closure errors and proportionately corrected the intermediate points, proved to exhibit shortcomings with certain flight patterns and involved an additional computational step in converting data to longitudes and latitudes. It is not desirable to calculate the position data in terms of corrected along-track and across-track coordinates because these data have no meaning unless both a starting point and a direction are additionally supplied. Consequently considerable effort was expended in exploring the possibility of using a spherical model of the earth and performing a direct coordinate rotation to geocentric coordinates. It was soon discovered that the degree of accuracy required for

compatibility with the Doppler accuracy over all azimuths could not be obtained for several reasons. First, if a path is to be flown from a point A to B, say in the northeasterly direction, one finds that the course, or azimuth, from B to A is not 180° different from that from A to B but in certain directions can differ 2° or more.² Also, with the use of an average figure for converting nautical miles to degrees, the calculated values of longitude and latitude for the data points contained excessive error. Results with expressions based on a spherical model of the earth were tested by mathematically performing data corrections and coordinate conversions and then plotting the resultant values on maps and comparing the degree of coincidence at known points. In addition, comparisons were made of the calculated figures with values tabulated by the USCGS Bearing and Distance VOR/TACAN* tables. The magnitude of the disagreements was beyond that contained in the position measurements, and, since approximations and "rounding-off" of values used during the process of data reduction must not introduce noticeable additional error into the resultant data, the spherical earth model was dropped.

Since it was found to be necessary to take into account the ellipticity of the earth in the computational formulas, the methods used by the USCGS were investigated.^{3,4} The expressions utilized in their work are derived on the basis of maintaining accuracies on the order of a few feet in distances of hundreds of miles. Our requirements are not nearly so severe. Several of the corrective factors in the USCGS expressions were dropped and average values were used for the ellipticity effect and distance-bearing conversions to obtain a set of reduced-accuracy expressions which proved to satisfy the conversion and plotting requirements of ARMS-II data. A unique peculiarity in the plotting requirements of ARMS-II data is that the final plotted product of the ARMS-II reduction and conversion process must be capable of being superimposed over a standard USGS map and must exhibit accurate, point-by-point matching with cultural and terrain features illustrated. Merely plotting a curve or a trace of the flight path is insufficient; coordinate correspondence of known points must be obtained. The expressions now in use give results that provide the required degree of accuracy. (Further considerations on accuracy requirements are discussed in Sec. 1.7.)

The sequential data manipulations within the computer can be tabulated in several generalized categories:

1. Erroneous data rejection
2. Acceptable data error corrections
3. Conversion of corrected position data to longitudes and latitudes
4. Conversion of the longitudes and latitudes to rectangular plotter coordinates

The complete set of functions performed by the computer as the preceding data operations are carried out will be described later. Of particular interest is the on-line monitoring function.

1.6.2 Conversion of ARMS-II Data to Longitude and Latitude

The criteria for examining and rejecting data have been cited earlier and will not be repeated here. Assuming that a set of acceptable raw data is available, the correction and conversion technique employed to obtain longitudes and latitudes of the data points will now be examined. In Fig. 1.5 the coordinates of the end points are represented by XO, YO and XN, YN . These map positions were overflowed, and the recorded across-track values, XTO and XTN , were entered into the flight notes. The ground data entered into the computer then consist of:

1. Longitude and latitude of initial checkpoint
2. Longitude and latitude of the end or the closure point
3. The recorded across-track values associated with each point

With the use of these data, it is necessary to associate each radiation-channel observation with its longitude and latitude and cause them to be plotted together for a permanent record of the survey. The quadrant angle of the line joining the check points is given by the expressions

*Visual Omni-Range/Tactical Air Navigation.

$$\left(\alpha' + \frac{\Delta\alpha'}{2}\right) = \tan^{-1} \left\{ 1.00432 \frac{\Delta X \cos [YO + (\Delta Y/2)]}{\Delta Y \cos (\Delta X/2)} \right\} \quad (1.1)$$

$$-\Delta\alpha' = \Delta X \sin \left(YO + \frac{\Delta Y}{2} \right) \quad (1.2)$$

where $\Delta X = XN - XO$

$\Delta Y = YN - YO$

α' = quadrant angle of line joining the checkpoints

1.00432 = average value, over the latitudes of the United States, of the quantity that takes into account the ellipticity of the earth

Special cases arise in the preceding expressions when the checkpoints lie on the same longitude or latitude. When the longitudes of the two points are identical, i.e., $\Delta X = XN - XO = 0$, then ΔY can be either greater than or less than 0, depending on whether the initial point is to the north or the south of the end point. Similarly, for east-west lying checkpoints, two possibilities exist when $\Delta Y = YN - YO = 0$.

Both $\Delta X = 0$ and $\Delta Y = 0$ can readily occur and are representative of a closed-loop flight path. If the survey is being conducted in a region in which distinguishable ground checkpoints are scarce, the navigator must sometimes begin and close a leg over the same landmark. A strong attempt is made to avoid situations of this nature because there is a deficiency of recorded data necessary to perform the machine corrections on the data points. If this pattern cannot be avoided, the length of the flight path is held to a minimum because, for the performing of longitude and latitude conversions on the data, the azimuth angle set into the Doppler must be entered into the flight notes and manually set into the computer for use with these data. Thus it must be assumed for these points that no heading error is present. If a documentation point can be recorded at some location along the loop, these difficulties can be overcome because in this case the loop is then split into two segments which the computer proceeds to handle in a normal manner.

It is to be pointed out that flying a closed loop occurs quite normally when the end of an area survey line is reached. The aircraft passes over the end point, and the pilot proceeds off the survey area to make a 180° turn. Frequently the same point could be used to begin the survey of the next leg. In fact, the same ground point can be used to close and start several of the neighboring legs. If the data for the flight paths resulting from such a tactic are retained and plotted, the plot becomes obliterated in the vicinity of the point, unintelligible loops being recorded in various directions. So that the final plotted map overlay will be neat and attractive, the loop data are discarded by the computer if the loop occurs as the final segment of a leg.

In general, the compass quadrant in which the angle α lies must be determined by testing ΔX and ΔY . Table 1.1 is a tabulation of the tests to be performed and the resultant handling of the quantities $[\alpha' + (\Delta\alpha')/2]$ and $(\Delta\alpha')$ in order to obtain α , the true azimuth between checkpoints measured from north.

In working through the formulas to solve for α , the computer must perform the comparative tests with ΔX and ΔY as indicated in Table 1.1 only once per leg. The value of α obtained by these calculations holds for each data point to be processed along that particular survey leg or leg segment. Once the angle α is found, the distance between the two points, DCJ, can readily be obtained by using either of the following expressions:

$$DCJ = 60.147 \frac{\Delta X \cos [YO + (\Delta Y/2)]}{\sin [\alpha' + (\Delta\alpha')/2]} \quad (1.3)$$

$$DCJ = 59.887 \frac{\Delta Y \cos (\Delta X/2)}{\cos [\alpha' + (\Delta\alpha')/2]} \quad (1.4)$$

In each case DCJ is in nautical miles. The constants on the right-hand side of the equations are degree to nautical-mile conversion factors. The value of 59.887 is the conversion for latitude degrees to nautical miles. In the direction of latitudes, the distance between consecutive

Table 1.1—DETERMINATION OF TRUE AZIMUTH QUADRANT BETWEEN CHECKPOINTS

ΔX	ΔY	α	Quadrant N W ⊕ E S
0	>0	0	↑
0	<0	π	↓
>0	0	$\frac{3\pi}{2} + \frac{\Delta\alpha'}{2}$	←
<0	0	$\frac{\pi}{2} + \frac{\Delta\alpha'}{2}$	→
<0	>0	$(\alpha' + \frac{\Delta\alpha'}{2}) + \frac{\Delta\alpha'}{2}$	↗
<0	<0	$\pi - (\alpha' + \frac{\Delta\alpha'}{2}) + \frac{\Delta\alpha'}{2}$	↖
>0	<0	$\pi + (\alpha' + \frac{\Delta\alpha'}{2}) + \frac{\Delta\alpha'}{2}$	↘
>0	>0	$2\pi - (\alpha' + \frac{\Delta\alpha'}{2}) + \frac{\Delta\alpha'}{2}$	↙

degrees on the earth's surface varies about 0.8% from the equator to the north pole. Since the conversion value cited is the result of averaging from the tip of Florida to the northern edge of the United States, the uncertainty in the figure is about 0.2%. The other factor, 60.147, is the conversion value for degrees longitude at the equator. Multiplication by $\cos[YO + (\Delta Y/2)]$ then accounts for reduction due to longitudinal convergence as a function of latitude.

Equation 1.4 is a slightly more accurate expression, and thus the computer employs this formula whenever possible. The result of the test for $\Delta Y = 0$ that is performed by the computer prior to the azimuth computation is utilized for the distance determination. If $\Delta Y = 0$, the computer selects Eq. 1.3 for finding DCJ; in all other cases Eq. 1.4 is used.

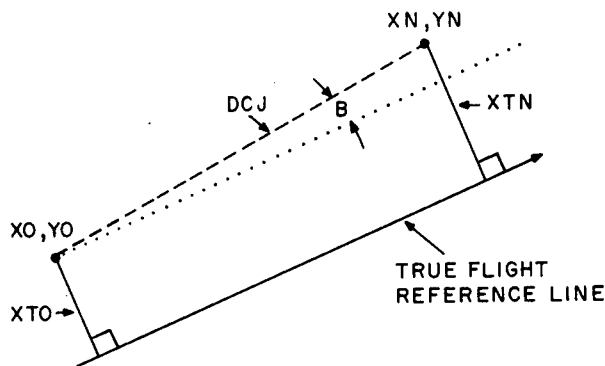

Fig. 1.6—True flight reference line as determined from across-track distances.

With the values for α and DCJ placed in storage, the computer proceeds to calculate the true flight reference azimuth ($\alpha + \beta$). The magnitude of this angle is found by using the recorded values of across-track distances of the initial and closing points in the following manner: It is known that the aircraft was over the two points when the respective across-track values were indicated. It follows then that the true flight reference line is the line that joins the positions of zero across-track for each point (Fig. 1.6).

The angle of interest is that which lies between the true flight reference line and line DCJ. If the angle is termed B, it can be mathematically defined as

$$B = \sin^{-1} \frac{XTN - XTO}{DCJ} \quad (1.5)$$

where DCJ is the distance between the two ground points as calculated and stored in the computer. A convention of signs is associated with across-track directions; right is taken as positive and left as negative. If the proper sign for the direction of the angle B in relation to α is maintained and if flight paths that are oppositely directed from the heading set into the Doppler are taken into account, a quadrant correction is applied to the angle B which gives the angle β to be used in the final coordinate computation. The relations established are listed in Table 1.2.

Table 1.2—ERROR ANGLE QUADRANT CORRECTION

XTN - XTO	ATN - ATO	β
≤ 0	≤ 0	$\pi + B$
≤ 0	> 0	$2\pi - B$
> 0	≤ 0	$\pi - B$
> 0	> 0	B

The column ATN - ATO refers to the difference of along-track indications at the points XO, YO and XN, YN. If for any reason the pilot must fly a reverse line from the heading set in, such as may happen during end-of-segment turns, a documentation point can be recorded which will not confuse the computer.

The indicated along-track values are also known to contain a linear error. The calculated distance between checkpoints, DCJ, is used in conjunction with the angle β to find the corrected along-track value of each data point. The true along-track distance between checkpoints is calculated from

$$AT \text{ true} = DCJ \cos \beta \quad (1.6)$$

and the corrected along-track values, ATPC, are given by

$$ATPC = (ATP - ATO) \frac{DCJ \cos \beta}{ATN - ATO} \quad (1.7)$$

where the ratio $(DCJ \cos \beta / ATN - ATO)$ represents the corrective ratio to be applied to the along-track value of each data point. The quantity ATP is the recorded along-track value of the *Pth* data point, and ATO is the along-track value recorded at the initial checkpoint. The value of ATO is generally, not zero, but 10.00 miles. The computer handles each segment as though it were a completely independent entity; if the point represented by ATN were the third documentation point on line, ATO would take the along-track value registered at the second documentation point.

Since all along-track and across-track values are calculated with respect to the segment or leg initial point, it is convenient to consider that both values are zero at that point. The correction formulas then supply differential values with respect to the initial point. With the use of the differential values so obtained, a coordinate rotation to the compass axes is applied about the initial point through the angle $(\alpha + \beta)$ which then, in essence, converts the along-track and across-track distance coordinates into east-west and north-south distance coordinates reckoned from the initial point. Mathematically, the transformations described can be expressed in the following manner. Beginning with

$$ATPC = (ATP - ATO) \frac{DCJ \cos \beta}{ATN - ATO} \quad (1.8)$$

$$XTPC = XTP - XTO$$

where XTPC and ATPC are the corrected across-track and along-track distance values prior to coordinate rotation, east-west and north-south distance conversions from the initial point are given by

$$XD = XTPC \cos (\alpha - \beta) + ATPC \sin (\alpha - \beta) \quad (1.9)$$

and

$$YD = ATPC \cos (\alpha - \beta) - XTPC \sin (\alpha - \beta) \quad (1.10)$$

where XD is the distance of point P from XO,YO along an east-west direction and YD is the distance of point P from XO,YO along a north-south direction. Figure 1.7 illustrates the con-

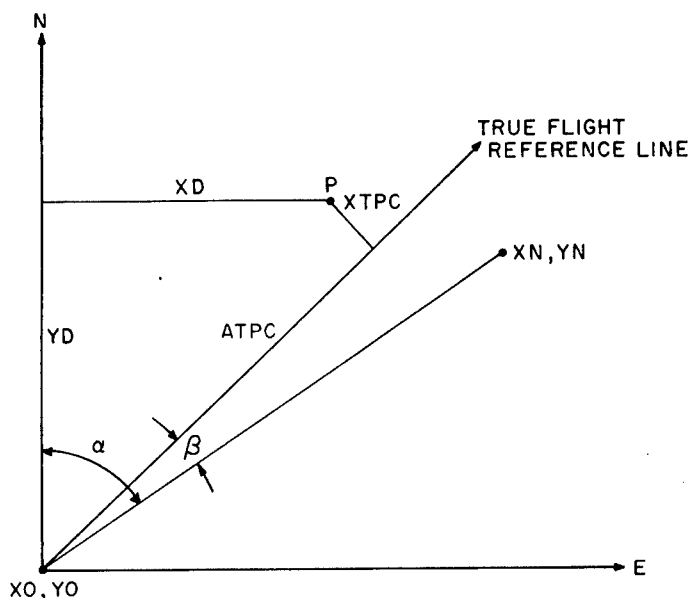

Fig. 1.7—Along-track and across-track distance correlations to east-west and north-south distances.

versions cited for the data point P. It is worth repeating that the sign convention attached to the angle B supplies the correct sign for β regardless of the flight-path quadrant or across-track direction.

Since the longitude and latitude of the initial point are given by the ground data, the computer calculates the earth coordinates of each intermediate point P by the following conversions:

$$YP = YO + \frac{YD}{59.887} \quad (1.11)$$

$$XP = XO - \frac{XD}{60.147 \cos YP} \quad (1.12)$$

where YP is the longitude of the point P and XP is the latitude of the point P. The constants in Eqs. 1.11 and 1.12 are the same as those used previously. They are the conversion factors between nautical miles and degrees.

1.6.3 Conversion of Longitudes and Latitudes to Rectangular Plotter Coordinates

The large-area (30 by 30 in.) plotter used to plot the data requires an input that is in terms of counts. That is, the manufacturer's specification of the span of each coordinate axes is given in terms of ± 9999 increments of distance. Each increment is called a count. The scale-

factor controls on the plotter allow expansion or contraction of the incremental distance per count within the range of 0.0004 to 0.030 in. per count. That is, a full 9999 counts can be contained in 4 in. of plotting surface as one extreme and continuously expanded to 1000 counts in 30 in. as the other. Hence a scale range is available which will permit plotting to any map scales from 1 : 24,000 to 1 : 250,000 without recalculation of the input data.

Experimental plotting of the data has shown that, over an entire survey area, the convergence of longitudes and the curvature in latitudes must be taken into account. If the position data are converted to rectilinear coordinates and superimposed on the corresponding maps, correspondence of the data points with the map points is not obtained. A displacement of as much as $\frac{1}{4}$ in. can be present on the northern points of an area if the southern points are made to coincide. The magnitude of the mismatch depends on the size of the area being plotted and the latitude in which it occurs.

The computer is programmed to convert the longitude and latitude position information into X and Y axes counts which contain the necessary allowance for conversion and curvature of the geocentric coordinates. The methods of the USCGS by which exact solutions to spherical triangulation problems are solved again were representative of too great a degree of sophistication for ARMS-II data plotting. Consequently an empirical approach was employed which gives the required results with a degree of accuracy that is compatible with that of the maps to which the data are to be mated.

(a) *Latitude Conversion and Correction.* The conversion and correction procedure for the latitude of a data point, P, consists first of determining the linear distances it lies from the plot origin as a function of map scale. The figure for curvature effect is attached to this result, and the final expression is converted to plotter count coordinates. From tabular values of feet per second of latitude arc as a function of latitude as given by *Surveying Tables*,⁵ it is found that the average value over the United States is 101.15 ft per second of arc. Conversion to miles shows that the average distance, D, between latitude degrees is 68.966 statute miles, i.e., $D = 68.966 (YP - YO)$ statute miles. On USGS 1 : 250,000 scale maps (4 miles per inch nominal maps), the actual scale is 3.94 statute miles per inch. In terms of linear map displacement, D_m , D becomes

$$D_m = \frac{68.966 (YP - YO)}{3.94}$$

$$= 17.505 (YP - YO) \text{ inches of map} \quad (1.13)$$

where YP is the latitude of data point P and YO is the latitude of plot origin.

For determining the magnitude of the latitude curvature effect, reference was made to USGS quadrangles of 1 : 250,000 and aeronautical sectional charts of scale 1 : 500,000 for several latitudes in the northern and southern parts of the United States. The departures of the latitudes from straight lines were measured, and an average figure of 0.08 in. of map per degree of longitude displacement from the map center-line longitude was obtained. Although the parallel of latitude is curved, a linear correction factor is sufficiently accurate for ARMS-II data. A check of the value by experimentally plotting points of known location showed that the constant of Eq. 1.13 required adjustment. Investigation revealed that aeronautical charts are constructed with the use of conformal Lambert projection, whereas the USGS maps are made with the use of polyconic projection. Fitting the latitude distance equation to the USGS maps showed a small adjustment of the latitude difference multiplier, and a corrected addition term was necessary for good fit. The distance equation becomes

$$\text{Map scale} = 1 : 250,000$$

$$\text{Latitude distance} = 17.46 (YP - YO) + 0.02 |XO - XP| \text{ map inches} \quad (1.14)$$

On large-scale maps, i.e., 1 : 62,500 and 1 : 24,000, the latitudes and longitudes are very nearly rectangular. Empirical fitting of Eq. 1.14 to these maps shows that the contribution from

the term $0.02 |XO - XP|$ is not negligible but serves to make the quadrangle corners and the plotted corner points come into closer alignment.

The conversion of the map distances to plotter counts is based on the use of the full 9999 counts available for 1:250,000 scale maps. If data covering a normal-size survey area of 100 by 100 miles were plotted as a nominal 4 miles per inch overlay, the dimensions of the area boundaries would be 25.34 in. Hence the plotter count is calibrated at 10,000 counts per 12.67 in., the total count being rounded off. For the 1:250,000 scale map, the latitude distance in terms of plotter counts, Y , becomes

$$Y = 17.46 (YP - YO) + 0.02 |XO - XP| \frac{10^4}{12.67} \quad (1.15)$$

$$Y = 13,748 (YP - YO) + 16 |XO - XP| \text{ counts} \quad (1.16)$$

It is, of course, understood that the plotter count $Y = 0$, $X = 0$ represents the center of the plotting surface and also the center of the area or region being plotted. The plotter count calibration for different scale maps is given in Table 1.3.

Table 1.3—X-Y PLOTTER COUNT CALIBRATIONS

Map scale	Count calibration
1:250,000	9999 counts/12.7 in.
1:62,500	2959 counts/15 in.
1:24,000	1135 counts/15 in.

To plot at 1:62,500 (nominal 1 mile per inch), the operator first locates the origin, $X = 0$, $Y = 0$, at the center of the plotting board. He next moves the plot arm to the X-direction plotter border and sets in a count of 2959. Repeating this step at the plotter Y boundary then places the plotter in calibration since both plus and minus entries are used as directions from the origin.

(b) *Longitude Conversions and Corrections.* Since the plotting board is rectangular, the same considerations for longitude distance exist as for latitude except that the gain in the longitudinal direction is a function of the latitude of the point P being plotted. (Equation 1.15 shows that the latitude distance is affected by the longitudinal displacement of the point P from the plotting origin.)

If a plot of the tabular values of feet per second of longitude, as given by surveying tables, vs. degrees latitude is compared to a plot of the equation

$$D_x = 100.25 \cos (YP - 1.0) \quad (1.17)$$

where D_x is in feet per second of longitude and YP is the latitude of the point P, the deviation in the values at latitude extremes of 25 and 50° is found to be less than 0.7% of the tabulated value. At all intermediate latitudes the difference is very small, being less than 0.1% between latitudes 30 and 40°. Hence Eq. 1.17 was used as an acceptable approximation to longitudinal map displacements as a function of latitude. Proceeding as before to find map distance gives

$$D_m = 17.348 \cos (YP - 1.0) \frac{\text{inches of map}}{\text{degree longitude at latitude } Y}$$

Introducing the longitudinal difference of the point P from the plot origin, i.e., $(XO - XP)$, gives

$$D = 17.348 \cos (YP - 1.0) \times (XO - XP) \text{ inches of map} \quad (1.18)$$

After the conversion to plotter count through multiplication by 10,000 counts per 12.67 in., the longitudinal coordinate for the plotter is given as

$$X = 13,660 (XO - XP) \cos (YP - 1.0) \text{ counts} \quad (1.19)$$

With the origin 0, 0 at the center of the plotter board, the count calibration for longitude conversion is the same as that for latitude; therefore the data in Table 1.3 hold in both horizontal and vertical directions on the plotter.

The longitude and latitude conversion equations solved by the computer and handled as a separate output are given by

$$\begin{aligned} X &= 13,660 (XO - XP) \cos (YP - 1.0) \text{ counts} \\ Y &= 13,748 (YP - YO) + 16 |XO - XP| \text{ counts} \end{aligned} \quad (1.20)$$

where X = longitudinal equivalent plot distance

Y = latitudinal equivalent plot distance

YP = latitude of the point being plotted, P

XP = longitude of the point being plotted, P

XO = longitude of point used for 0, 0 plot point

YO = latitude of point used for 0, 0 plot point

1.6.4 Determination of Plotter-origin Coordinates

For the computer to calculate the X-Y plotter coordinates, the quantities XO and YO, as defined, must either be calculated by the machine or be inserted into the input data. Once obtained by the computer, the geocentric coordinates for each plot area are converted by using these points as reference, and, as mentioned, scale-factoring procedures will provide any size plot required. The manner in which the computer is programmed to provide plot data is based on the scale of overlay that it is anticipated will provide the most useful plotted format. The 1:62,500 scale USGS maps have proved to be an appropriate base for the overlay because the accuracies and detail present in the topographic and cultural features are compatible with both data-collection techniques and presentation clarity. (These maps are also employed as the standard survey-flight maps.) It is convenient to construct an overlay from finished data which will match with individual quadrangle maps. In this way fractional parts of quads are avoided except at survey-area boundaries, and handling and reading ease is gained. In addition, an overlay section can be identified simply by the USGS quadrant names as tabulated by their index maps. Hence, for this format to be obtained from the computer, several additional quantities are entered on the data instruction cards which permit the computer to calculate the central coordinates with which any point P in the survey will be associated. This feature is accomplished in the following manner.

The USGS 1:62,500 quadrangles are bounded by 15-minute increments and measure about 14 in. wide and 17 in. long over the United States. So that as much of the plotter surface as possible can be utilized, with the goal of quadrangle matching being maintained, plotting areas are taken in increments of 30 minutes east-west and 15 minutes north-south. With the allowance of space on the bottom of the overlays for scale entries, identifications, etc., the plotting surface is satisfactorily utilized. The reference plotting coordinates are then calculated to be the central coordinates of the double quadrangle overlay. The machine carries out the longitude calculation by application of the following two expressions:

$$X_{\text{edge}} = \text{INT} \left[\frac{(XP - XG)}{\Delta X} \right] \times \Delta X \quad (1.21)$$

$$X_{\text{orig}} = XG + X_{\text{edge}} + \frac{\Delta X}{2} \quad (1.22)$$

where XG = reference longitude

XP = longitude of the point

ΔX = plot-quadrangle longitude difference

INT = definition as given on page 32

X_{edge} = eastmost plot-quadrangle boundary longitude
 X_{orig} = plot-quadrangle central longitude

Equation 1.21 determines the longitude on the east boundary of the plot quadrangle by using only the integer (INT) part of the division indicated. The quantity XG is a reference longitude, generally taken from Greenwich as 0. Substitution of Eq. 1.21 into Eq. 1.22 gives the central longitude, X_{orig} , of the plot quadrangle with which the point P is associated. Values for XG and ΔX are entered into the machine on the input data instruction card. This means the width of plot region can be controlled, by varying ΔX , and any longitude can be used as a reference longitude, XG. For instance, if a special area were flown and the only maps available were local or county maps, XG could be assigned the value of the survey-boundary longitude and ΔX the longitudinal span of the surveyed ground. Substitution of these values into Eqs. 1.21 and 1.22 would then give the central longitude of the surveyed area, since in this case the integer part of $X_{\text{edge}} = 0$, and the plotted points would lie symmetrically about the origin.

A similar procedure is followed by the computer in determining the central latitude of a plot area. In this case the quantities of interest are YG and ΔY , which have comparable definitions with the equivalent longitudinal quantities. The equations are

$$Y_{\text{edge}} = \text{INT} \left[\frac{(YP - YG)}{\Delta Y} \right] \times \Delta Y \quad (1.23)$$

$$Y_{\text{orig}} = YG + Y_{\text{edge}} + \frac{\Delta Y}{2} \quad (1.24)$$

The values of X_{orig} and Y_{orig} found by Eqs. 1.22 and 1.24 become the values used for XO and YO in Eq. 1.20, from which plotter coordinate counts X and Y are found for all points P that are processed.

It should be understood that the plotter coordinate counts of each data point P are those associated with the central coordinates of the plot quadrangle in which that point occurs. Since the quantities ΔX and ΔY are manually selected prior to machine processing, they can be chosen to coincide with the width of the survey area desired. This procedure would provide plot counts of each survey point in relation to the central coordinates of the survey area and would permit the operator to make but a single plotter-origin setup to plot all the survey data on small-scale overlays, such as 1 : 250,000, 1 : 500,000, or 1 : 1,000,000.

In normal usage—that is, plotting at a scale of 1 : 62,500 with the plotter-origin coordinates coinciding with the central coordinates of two adjacent USGS quadrangle maps—the data cards must be run through a card sorter prior to being used with the plotter. The cards are sorted according to the data points associated with the quadrangle maps. Although this procedure represents an additional card-handling step, no plotter time is lost by the crossarms in seeking points that lie off the plotting surface since the plotting and sorting operations can proceed simultaneously except for the very first plot area.

1.7 ACCURACY REQUIREMENTS OF THE PROCESSING METHOD

The final data-presentation products of the ARMS-II automatic data-processing system consist of both map overlays and decimal tabulations. The error introduced by the equations which correct the instrumental error in the data and which perform the coordinate conversions is the largest single source of uncertainty. The additional areas in which uncertainties arise are those due to human error in the map measurements, those due to instrumental error introduced by the plotter, and those inherently contained in the maps. Since the finished data are to be reassociated with the same maps, the effect of the last source can be discounted.

The uncertainties present in the values of the recorded radiation levels⁶ are discussed fully in Report CEX-59.4(Pt.II). Effects due to meteorological parameters, background corrections, statistics, etc., are considered. The degree of error present in the radiation level is taken as $\pm 9\%$.

It is necessary, then, to investigate the magnitude of the uncertainties introduced during the position-data reduction process.

The final map requirement is the nominal 4 mile per inch overlay showing aeroradioactivity units. This map is obtained by photographic reduction of nominal 1 mile per inch maps, upon which the points are plotted and from which checkpoint coordinate values were measured. The 1 mile per inch maps are not exactly 1 mile per inch but 1 in. = 0.985 statute mile; also 1 in. = 0.856 nautical mile. On these maps

$$\left. \begin{aligned} \frac{1}{16} \text{ in.} &= 0.054 \text{ nautical mile} \\ &= 0.062 \text{ statute mile} \end{aligned} \right\} 330 \text{ ft}$$

Data are collected at an aircraft speed of 150 mph = 220 ft/sec, and, in the period print-command mode (3 sec), data are taken every 660 ft, or about every 0.1 nautical mile. On the 1 mile per inch maps, this is about $\frac{1}{8}$ in.

In radiation-channel-change print command, print-out occurs every 1.4 to 1.5 sec in moderate to high radiation gradients, which corresponds to approximately 330 ft, or $\frac{1}{16}$ in. on the 1 mile per inch maps. Resolving 0.1 nautical mile on the map is the same as resolving about 0.0017° of latitudinal arc, and, for more rapid level change print-out, 0.00085° of latitude is resolved. The longitudinal resolution is a function of the latitude and is consequently a larger angle than the latitudinal arc.

Hence, for a reasonable compromise in accuracy, the longitude-latitude conversion equations are set up to give results accurate to 0.001° . In practice, along-track and across-track distances are measured in hundredths of miles. In these measurements an uncertainty of ± 0.01 nautical mile corresponds to $\pm 0.000017^\circ$ of earth's arc.

Table 1.4 is a tabulation of conversion factors for 0.001° latitude for various map scales.

Table 1.4—CONVERSION FACTORS FOR 0.001° LATITUDE

Scale	Inch	Miles	
		Statute	Nautical
1: 24,000	0.19	0.07	0.06
1: 31,680	0.14	0.07	0.06
1: 62,500	0.07	0.07	0.06
1: 250,000	0.02	0.07	0.06
1: 500,000	0.009	0.07	0.06
1: 1,000,000	0.004	0.06	0.06

In the ground measurements of longitude and latitude from the 1 mile per inch maps, an error of $\frac{1}{32}$ in. gives an uncertainty of 0.00043° . Hence, for maintaining position data conversions that are accurate to 0.001° , the uncertainty in the coordinate measurements must be no greater than $\pm \frac{1}{32}$ in.; measurements within this limit are fairly easy to make.

The accuracy of the X-Y plotter must be such as to be compatible with the preceding measurements, particularly for high-resolution survey work. If the compilations and measurements are maintained within the described bounds, the plotter error should not be greater than ± 0.015 in. The scale factor used for the plotting operations always has attached to it an uncertainty of ± 1 count. When data are plotted at a scale of 1: 62,500, each count is equal to 0.005 in. At a scale of 1: 24,000, ± 1 count gives an uncertainty of ± 0.013 in., which is the largest scale at which plotting would be done. The uncertainty of each point, ± 0.013 in., is within the prescribed bound of ± 0.015 in. Hence the uncertainty introduced by the plotter for all scales is less than that which might be introduced from the map measurements.

If the map data are maintained within the limits described, compatibility is obtained between the Doppler navigational along-track and across-track ground resolution and the coordinate measurements from the maps, coordinate calculations, and data-point plotting. An estimate of the maximum uncertainty generated by the last three items can be obtained by summing their variance,

$$\sigma_{\text{tot}}^2 = \sigma_m^2 + \sigma_c^2 + \sigma_p^2 \quad (1.25)$$

where σ_{tot} = total uncertainty
 σ_m = uncertainty in map measurements
 σ_c = error due to calculation of the coordinates
 σ_p = error introduced by the plotter

Converting the values for degrees and map distances to nautical miles for the individual contributions on 1 : 62,500 maps and substituting in Eq. 1.25 gives

$$\begin{aligned}\sigma_{\text{tot}} &= (0.014^2 + 0.027^2 + 0.004^2)^{1/2} \text{ nautical mile} \\ &= \pm 0.03 \text{ nautical mile (almost 180 ft)}\end{aligned}$$

The maximum uncertainty present in each data point is then about ± 180 ft.* This analysis shows that the machine corrections and conversions introduce the largest error. This is to be expected since the longitude and latitude are calculated only to the nearest 0.001° .

REFERENCES

1. J. E. Hand, *An Automatic Data Handling and Presentation System for Use with the Aerial Radiological Monitoring System*, Report S-30, Edgerton, Germeshausen & Grier, Inc., Apr. 19, 1961.
2. U. S. Department of Commerce Coast and Geodetic Survey, *Bearing and Distance Tables, VOR/TACAN*, 2nd ed., 1959.
3. Aeronautical Chart and Information Center Technical Report No. 59, *Geodetic and Azimuth Computations for Lines Under 500 Miles*, ACIC Headquarters, St. Louis, Mo., 1960.
4. U. S. Department of Commerce Coast and Geodetic Survey Special Publication No. 8, *Formulas and Tables for the Computation of Geodetic Positions*, U. S. Government Printing Office, Washington, D. C., 1952.
5. TM-5-236, War Department Technical Manual, *Surveying Tables*, 1940.
6. J. E. Hand, R. B. Guillou, and H. M. Borella, *Aerial Radiological Monitoring System. Part II. Performance, Calibration, and Operational Checkout of the EG&G ARMS-II Revised System*, USAEC Report CEX-59.4, Oct. 1, 1962.

*An experiment to determine the extent of the error introduced by the pilot in starting the Doppler over a checkpoint has been previously described.⁶ The error is shown to average ± 50 ft.

Chapter 2

MACHINE MANIPULATIONS OF ARMS-II DATA

2.1 INTRODUCTION

The requirements for processing and displaying ARMS-II data are listed as follows:

1. Hardware requirements:
 - a. Equipment for conversion of punched-paper-tape codes into a form acceptable by a computer
 - b. A high-speed digital computer with a large data-handling capacity
 - c. An X-Y plotter and associated data-input device
2. A computer program that can provide the following functions:
 - a. Monitor the progress of a computer run and indicate with diagnostic print-outs any deviation from normal operation
 - b. Read as inputs all the observation data that were originally punched into paper tape
 - c. Read as inputs longitude and latitude of known checkpoints or landmarks
 - d. Perform rejection tests on observation data to remove unusable and erroneous information
 - e. Perform corrections on Doppler information and convert corrected Doppler position indications to longitude and latitude coordinates
 - f. Print in a compact, readable, and attractive form the radiation channel, earth coordinates, and sensitivity of each point that was processed
 - g. Convert earth coordinates to plotter information in a form that is compatible for the plotter input

The nature and priority of ARMS-II work demand use of a computer that has a high degree of availability and versatility as well as speed and large data-storage capacity. The IBM-704 is ideally suited to these requirements. Since the IBM-704 is basically a magnetic-tape-input machine, the binary raw-data tapes must be converted to a compatible input form. This procedure is accomplished through the IBM-1401 computer. The binary data on the tapes are converted to card information in the ARMS-II laboratory by using an IBM-047 tape-to-card converter. In addition to perforating the cards, this unit records the punched data in decimal form on the top border of the cards; this allows visual monitoring of the data. A keyboard option permits manual entry on cards of the ground data. The intermediate set of cards generated by the IBM-047 provides the input for the IBM-1401, which then transfers the data to magnetic tape in a format that is acceptable as the IBM-704 input.

The ARMS-II computer program, which supplies the instructions to the computer on how the data are to be processed, is written in the FORTRAN language. Since FORTRAN is a universal language that is available on most large computers, the ARMS-II data-processing program is not limited to being executed on the IBM-704 but can be used on any machine which meets the storage requirements of the program and which has FORTRAN available. Using FORTRAN, the programmer can enter a problem in mathematical and logical expressions onto

IBM cards. The statements then serve as the input to a FORTRAN compiler program, which transforms the logic statements into computer instructions and enters them again on cards.

The result is a deck of cards that contains the computer instructions in so-called "machine language" and is used to direct the computer to perform the calculations specified by the FORTRAN statements.

After being processed in the IBM-704, the data are reentered on magnetic tape. There are two sets of output data. The first consists of survey-area, data, leg-number, longitude, latitude, radiation-channel, and radiation-sensitivity information for each recorded point. The second consists of the longitude and latitude in terms of plotter input coordinates and the associated radiation level. The central coordinates against which each point is plotted are also entered in the second output.

The former data are processed through the IBM-407 lister, from which a decimal tabulation of the data is printed. The latter set of output data is processed again through the IBM-1401 and is entered on IBM cards, which form the X-Y plotter input. The plotter cards are decoded by an IBM-523 summary punch; the output drives the plotter circuits.

The longitude and latitude magnetic tape and the X-Y plotter cards are placed in permanent storage when the plotting operation is completed. The maps generated during this step of the process are used in determining the boundaries and locations of aeroradioactivity units. Once these are satisfactorily constructed, the nominal 1 mile per inch plotted map overlays are photographically reduced to 4 miles per inch, with the plotted points subdued and the aeroradioactivity units highlighted.

2.2 PREPARATION AND FORMATS OF INPUT DATA

Two kinds of data are generated during a survey. One kind is the data punched automatically into paper tape and includes the leg number, Doppler position coordinates, radiation channel, and sensitivity. These are collectively called the observation data. The other kind is the ground data. Ground data consists of the leg number, the number of documentation points for the leg, the initial across-track values of the leg, the longitude and latitude for each documentation point, and titles that are to be printed on each page of the final printed report after processing of the leg. Also included with the ground data is the computer compilation sheet on which is entered editing remarks for each leg. Information entered on this sheet generally affects the preparation of observation data for computer processing.

2.2.1 Punched-paper-tape Format

A data word on the punched paper tape consists of 15 characters on 8-channel tape.

A data word has seven fields: 3 characters, leg number; 2 characters, radiation channel; 4 characters, along-track value; 3 characters, across-track value; 1 character, across-track direction; 1 character, sensitivity; and 1 character, word mark (end of entry).

The tape codes are a displaced binary-coded decimal and are identified as:

Channel 1: parity punch

Channel 2: not used

Channel 3: punched for word-mark character

Channel 4: punch has value 8; also punched for word mark

Channel 5: punch has value 4; also punched for word mark

Channel 6: punch has value 2; also punched for word mark

Channel 7: punch has value 1; also punched for word mark

Channel 8: punched only for word-mark character

A word mark consists of punches in channels 1, 3, 4, 5, 6, 7, and 8 as indicated. So that a data entry can be decoded to decimal equivalent, the values punched in the associated paper-tape channels are added. Channel 1 is not considered when the values in the channels are added to determine the decimal equivalent.

2.2.2 Punching Cards from Paper Tape

With the use of an IBM-047 tape-to-card converter, the data on the punched paper tape are transferred to IBM cards. Automatic operation of the unit is obtained through proper wiring of the patch board and by inserting a matching card in the control drum.

2.2.3 Control-panel Functions

The control panel operates in the following manner:

1. A punch in channel 8 on the paper tape indicates a word mark.
2. All characters on the tape with no punch in channel 8 are decoded by the control-panel wiring logic to punched-card decimal equivalent.
3. At the beginning of an operation, tape is fed automatically until a word mark is detected.
4. The word mark starts the card punch, with the word mark not being punched.
5. Fourteen characters per data point are punched from tape onto the card.
6. Steps 4 and 5 are repeated four times on each card, resulting in five words per card.
7. When the card reaches column 71, it is released automatically. A punch is put in row 1, column 82, and another card is fed. Steps 4 through 6 are repeated until all the tape has been converted.
8. If a word mark is detected in the data field, the card is released immediately with a punch put in row 4, column 82. A new card is fed in, and the tape feeds automatically until a word mark is found. At this point operation proceeds normally.

Data from the cards can be decimally printed with the IBM-407 lister using a special control panel. A printed record of the input information is sometimes useful during editing and setting up computer runs.

2.2.4 Arranging Data for a Computer Run

The sequential arrangement of the observation-data cards, the ground-data cards, and the computer control cards is shown in Fig. 2.1.

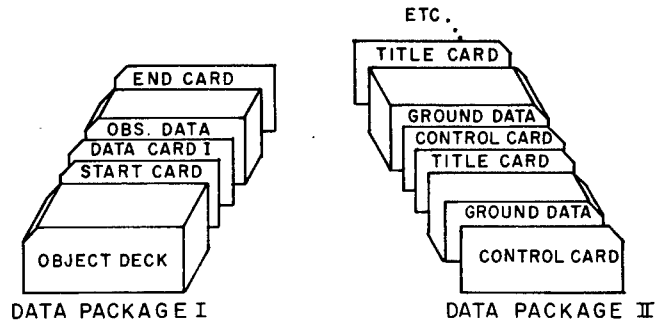

Fig. 2.1—Computer input-card sequence.

(a) *Data Package I.* Data Package I consists of the computer program OBJECT DECK, DATA CARD I, OBSERVATION DATA, and two types of control cards. The cards are stacked in the order shown in Fig. 2.1 and are entered in the IBM-1401 computer. This machine transfers the data from the cards to magnetic tape. The tape is assigned as tape 5 for entry of the data into the IBM-704 computer.

The OBJECT DECK is a stack of cards that contain in column binary format the computer instructions for processing the ARMS-II data.

The START CARD is one of the control cards mentioned. It is punched with a plus in column 71 and a 1 in column 72. This card must precede all occurrences of DATA CARD I.

DATA CARD I contains rejection test 6, parameters A and B, the reference plot coordinates XO, YO, and plot area dimensions DELTX, DELTY. These values may be changed at any

time during a run by inserting in the observation data a start card followed by the new data card. The formats for the data entered on this card are as follows:

- A: Punched in card columns 1 through 10. The value for A may be punched anywhere in this field if a decimal point is included in its proper place.
- B: Punched in card columns 11 through 20 anywhere in the field with decimal point punched.
- XO: Punched anywhere in columns 21 through 30 with a decimal point included.
- YO: Punched anywhere in columns 31 through 40 with a decimal point punched.
- DELTX: Punched in card columns 41 through 50 with a decimal point punched.
- DELTU: Punched in card columns 51 through 60 with a decimal point punched.

The OBSERVATION DATA are obtained automatically from the punched paper tape by using the IBM-047 tape-to-card converter. Each card has five data words, with six fields in each word. The card columns for the first word are given here with the understanding that the following four words are placed consecutively on the card with the same format:

- Field 1: Leg number in card columns 1 through 3
- Field 2: Radiation channel in columns 4 through 5
- Field 3: Along-track value, columns 6 through 9
- Field 4: Across-track value, columns 10 through 12
- Field 5: Across-track direction, column 13
- Field 6: Sensitivity, column 14

No decimal points are punched on these cards but are automatically placed by the computer program. When the IBM-407 lister is used to print from these cards, the decimal points and signs are inserted automatically by the special control panel to make the print-outs more readable.

The END CARD is the last card of Data Package I. The computer program recognizes this as the end of the data and causes a normal exit to occur when the end card is read. All that is needed in this card is a minus sign punched in column 71 and a 1 punched in column 72.

(b) *Data Package II.* Data Package II consists of the ground data and is read on-line from the card reader. The reason for having ground data read on-line is that most errors may be corrected while a computer run is in progress if one has access to the ground data. Although the monitoring capabilities of the program are utilized, it is still handy, under adverse situations, to be able to exercise control over the ground data during processing. For each group of leg data that are in the observation deck, there is a corresponding group containing three types of cards in Data Package II. These are as follows:

Type 1: Control Card

1. Columns 1 through 3. Leg number to which this group of ground data belongs. The leg number is right-adjusted in columns 1 through 3, and no decimal point is punched.
2. Columns 11 and 12 contain the number of ground-data cards that follow. This input is right-adjusted in the field, and no decimal point is punched.
3. Columns 21 through 30 contain, anywhere in the field, the initial across-track value set into the Doppler at the initial point, and the decimal point is punched.

Type 2: Documentation-point Data. For each checkpoint indicated in the observation data, there must be a corresponding card in the ground data. An excess or a lack of ground data will be recognized by the program, and a possible error condition will be indicated. Ground data consist of the longitude and latitude of each checkpoint and are punched into the cards, one point per card, in the following formats:

1. Columns 1 through 10 contain the longitude of the checkpoint. The entry may occur anywhere in the field, and the decimal point must be punched.
2. Columns 11 through 20 contain the latitude of the checkpoint. The entry may occur anywhere in the field, and the decimal point must be punched.

Type 3: Title Card. Any desired alpha or numeric data may be punched in columns 1 through 36 of the title card. Data punched in columns 1 through 18 will be printed on the final

output report on each page of the corresponding leg opposite the word "LOCATION." Columns 19 through 36 will also be printed opposite the word "DATE" on each page. Therefore, for consistency in the outputs, some indication of the location should appear in the first 18 columns, and a date should appear in the second 18 columns. Any other information to be printed, however, may also be included in those fields.

2.2.5 Checking of Input Data Before Processing

The most important considerations in the editing of the input data correspond to rejection tests 1 and 2. These tests may reject large groups of data at one time or possibly the entire leg. For test 1, if no along-track value between 9 and 11 occurs between the initial point and the first checkpoint, the leg will be thrown out. When a leg is being prepared for processing, the data editor must be sure that the value occurs within these bounds. For test 2, the editor checks to ensure that three equal entries are not accidentally included in the data. Conversely, if a leg is to be discarded for any reason, he must be sure that the data contain at least three consecutive position entries that are identical and insert a new leg number at the beginning of new, good data. It is equally important that documentation points be correctly indicated. Care is also taken to ensure that the number of checkpoints indicated in the data is in agreement with the number of ground-data cards that have been prepared for the computer run.

The computer program will recognize a documentation point in the data under the following circumstances: (1) a data entry that is preceded and followed by any number of all-zero entries on either side and (2) the data point immediately following a single group of any number of all-zero entries. Normally the checkpoint will be indicated as the data point immediately following a single all-zero entry.

2.3 PERFORMING THE COMPUTER RUN

Observation data for consecutive legs are placed one behind the other. In most cases the data of consecutive legs will have no break between leg changes. However, if there is a break or if it is necessary to remove data from a few legs, it is required that there be more than 15 accepted data points remaining for the leg to be retained by the computer. Similarly, if there are less than 15 entries associated with a leg number, such as may occur during tests, the computer will recognize the conditions and ignore the unwanted information. However, a change of leg number must occur before 15 entries are obtained.

Ground data are punched into IBM cards from forms that are prepared after each flight. After a careful check, the ground data are placed in sequence to correspond to the ordering of observation data. Observation data are placed behind the OBJECT DECK with the proper control and data cards and then loaded onto magnetic tape to be designated at tape 5 during execution on the IBM-704 computer. The ground-data package is labeled "ON-LINE, 704," and is placed in the card reader that feeds into the IBM-704 before processing is begun. Once begun, processing will continue automatically until the END CARD is encountered, with the following exceptions.

If a stop occurs with an address of 52525₈ displayed in the lights of the computer console, a functional stop originating in the monitor has occurred. Processing can be continued by depressing the START button. When the end card is read or if an error is detected which cannot normally be corrected automatically, processing will terminate with an address of 77777₈ displayed on the light of the computer console. Also "END OF JOB" will be printed on-line.

There are only two intentional stops in the program. The first stop is any diagnostic print-out, in which the monitor stop displays 52525₈. The second stop is an END OF JOB stop, and it displays 77777₈. When this stop occurs, the job is to be removed from the computer since processing is either complete or can no longer continue. The monitor diagnostic on-line print-out is consulted to determine which has been the case. When processing is complete, tape 6 is removed and printed under program control. Plotter data have been written on tape 8, which is removed and punched onto IBM cards to be used as the input to the plotter.

Any other halt encountered during processing will be a FORTRAN stop, in which case the operator or systems people are consulted. If some unknown halt appears, either the run has been set up incorrectly or there has been a machine error.

2.4 REENTRY OF DATA

The machine process has been set up in such a manner that longitude and latitude data can be entered as an external input and can undergo conversion to plotter coordinates. The program that accomplishes this task is designated LLIN and is described in the next section.

2.5 MACHINE PROGRAM

2.5.1 Scope of the Program

The calculations to be performed by the computer have been written and compiled in a code that permits a wide latitude in the selecting of a computer. In the constructing of the program, an effort has been made to have the machine perform as large a fraction of the total effort as possible. The recognition of erroneous data and the required appropriate action have been incorporated into the processing instructions for those cases which field experience has indicated to represent the largest rate of occurrence. Since many of the possible flight patterns have not been flown and an equally large number of the possible equipment malfunctions have not yet occurred, the data-processing program is open-ended so that future revisions, additions, or deletions can easily be assimilated into the program. In this way the automatic data-processing criteria can keep abreast of the innovations dictated by the field work.

2.5.2 Program Structure and Machine Sequence

The machine program has been constructed as a sequence of computational block operations that begin with evaluating the quality of the data and end with printing out X-Y plotter coordinates. Each computational block that is caused to operate on the data is called a subroutine. The ARMS-II program contains ten subroutines. The main body of operational instructions, which includes accepting data, routine data to sequential manipulations, causing data print-out, etc., is called "MAIN." Figure 2.2 shows what may be considered a "physical image" of the program structure.

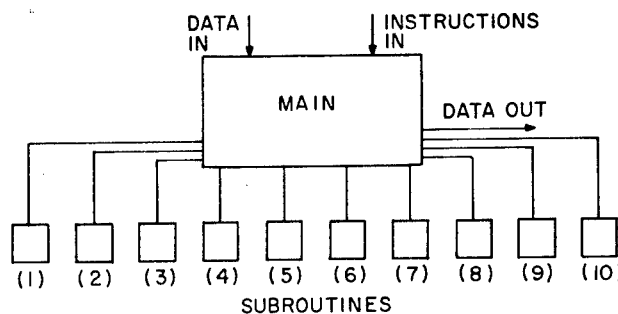
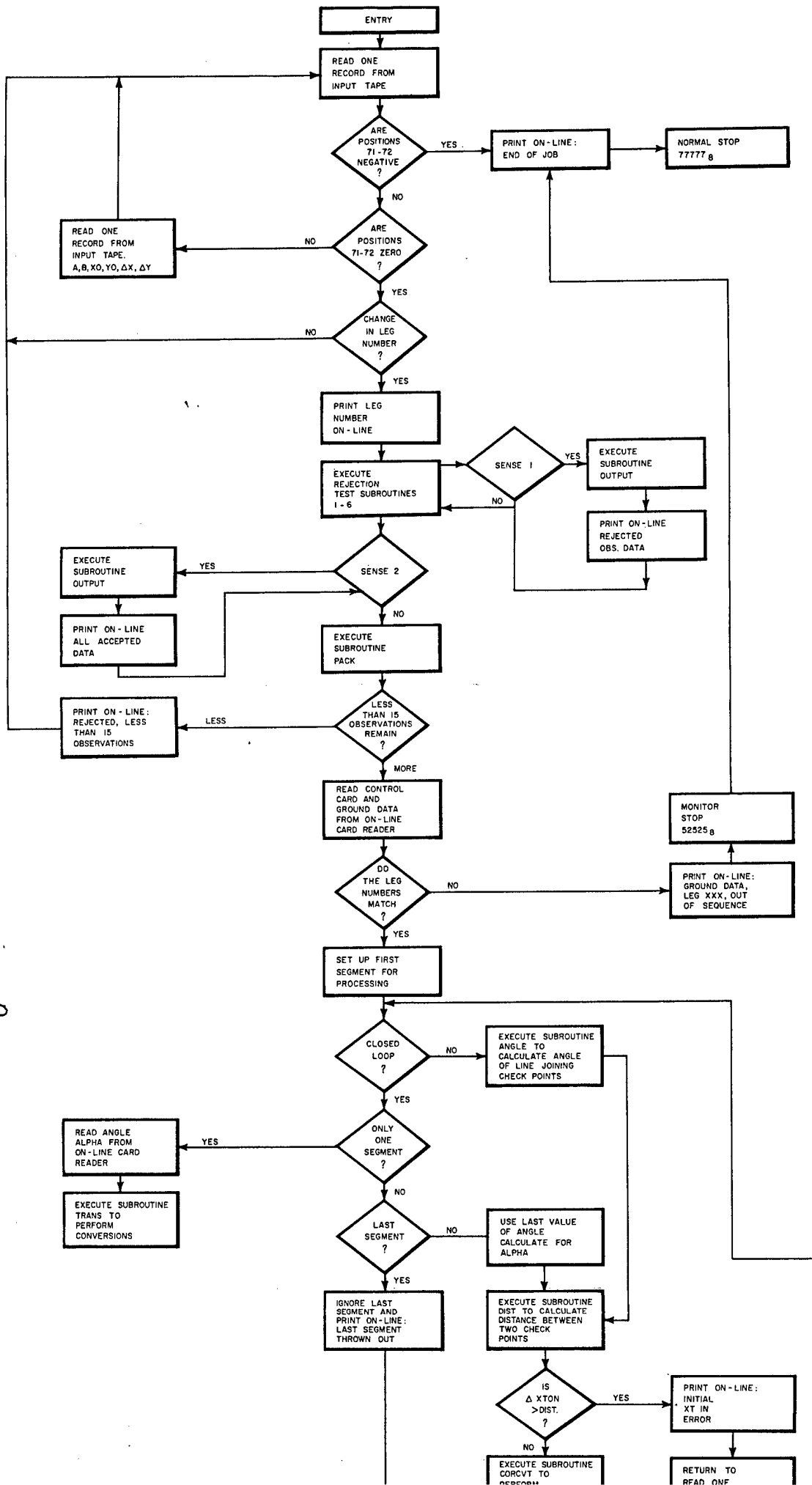

Fig. 2.2— Computer-program structure.

2.5.3 MAIN Program and Process Monitor

The purpose of MAIN is to read the observation and ground data, control the use of all subroutines, and provide a monitor that prints diagnostic information on-line during computer processing of the ARMS-II data.

The event sequencing of the MAIN program can be visualized by referring to Fig. 2.3. The functional details are given in the following paragraphs.



①

AI
2

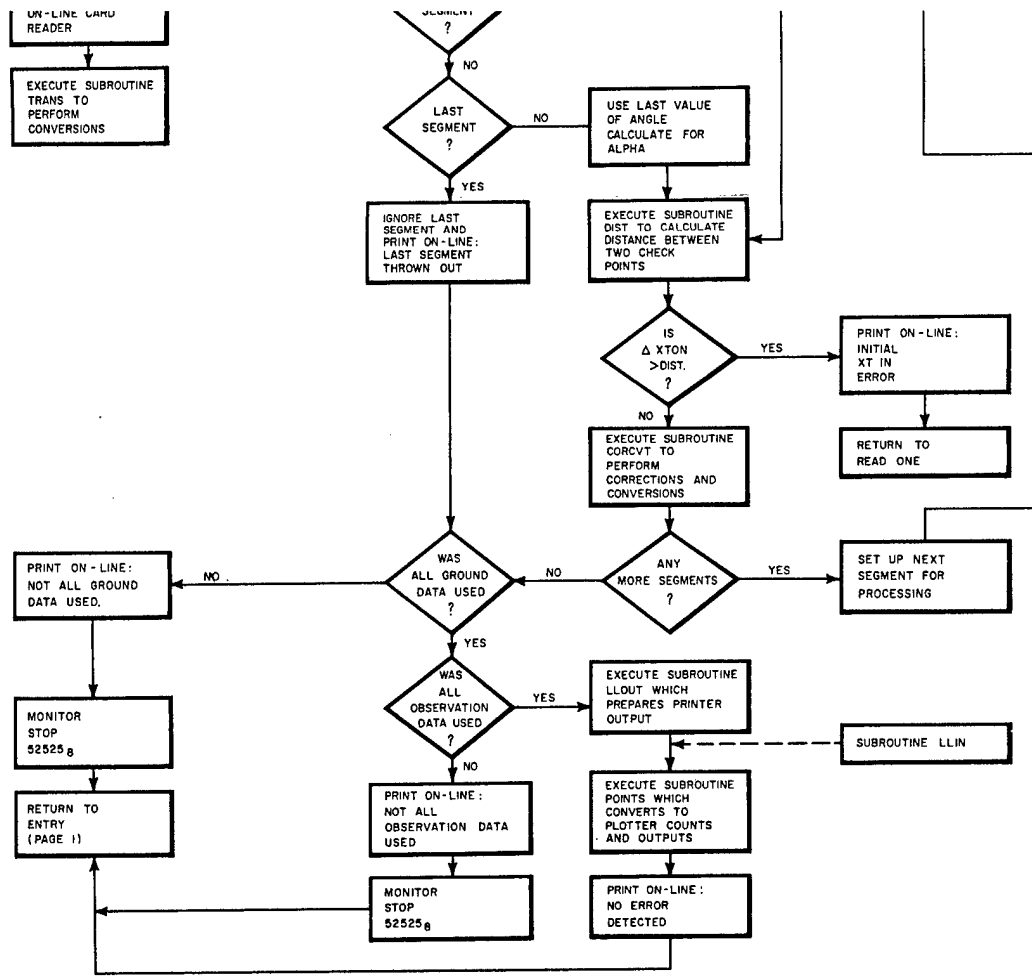

Fig. 2.3—ARMS-II computer-program and data-processing monitor.

2

One record, which corresponds to one card, is read from the input tape. The data corresponding to columns 71 and 72 on the input cards are tested for a negative value. If negative, "END OF JOB" is immediately printed, and a halt signifying the end of processing is encountered. (The testing actions encountered throughout the MAIN program are the diagnostic monitoring functions. These operations are indicated by the diamond-shaped boxes in Fig. 2.3.) If the values are positive, but not zero, the computer is instructed to read a record that contains the values A, B, XO, YO, DELTX, and DELTY, where A and B are parameters for subroutine RJECT6 and XO, YO, DELTX, and DELTY are parameters for the plotting subroutine POINTS.

A card containing ARMS-II observation data has the value zero in columns 71 and 72. After entry of the data onto magnetic tape, the information is read into the computer five points at a time until a change in leg number occurs. Zero entries which indicate that a documentation point follows are not interpreted as a leg change.

When a leg change is discovered by the program, reading is stopped and processing begins; the leg number is printed on-line.

Subroutines RJECT1 through RJECT6 are entered and executed. Between each rejection-test subroutine, the position of sense switch 1 is tested by the program. If sense switch 1 is down, subroutine OUTPUT is entered; this causes the observation data to be written on the output tape, which, when printed, indicates data points rejected by each rejection-test subroutine.

After all rejection tests are performed, the position of sense switch 2 is tested. If sense switch 2 is down, subroutine OUTPUT is called again, but this time only the acceptable data are written on tape. Production is normally executed with sense switches 1 and 2 up.

The MAIN program then enters subroutine PACK, which removes the rejected data and packs the good data into consecutive memory cells to facilitate further processing. After leaving PACK, the usable raw data for one leg remain in storage in an orderly fashion.

The MAIN program tests to determine if there are less than 15 data points remaining. If less, "REJECTED, LESS THAN 15 OBSERVATIONS" is printed on-line, and control is returned to the instructions in MAIN, where succeeding data are read from the input tape.

If more than 15 observations are present, the first card of a ground-data group is read from the on-line card reader. This card contains a leg number, the number of documentation points, and the initial across-track value. Following the first card, additional cards are read which continue longitude and latitude data of each documentation point.

The leg number associated with the observation data is compared with the leg number corresponding to the ground data read from cards. If comparison shows the two values not equal, MAIN causes "GROUND DATA, LEG XXX, OUT OF SEQUENCE" to be printed on-line. The leg number is that which is associated with the ground data. If this event occurs, a program halt is called with "52525_g" displayed on the computer console. Pressing the START button on the computer console causes MAIN to print on-line "END OF JOB," indicating a termination of processing.

If the leg numbers agree, processing continues normally. Each segment (the data between two consecutive documentation points) is processed one at a time as follows:

If the first documentation point happens to be the leg initial point, which generally occurs at the end of a closed loop, 10.00 is used for the initial along-track value; the initial across-track value is read from the ground-data card of the initial point. Otherwise, indicated values at the two points are used. The longitude and latitude of the two documentation points are next obtained. If the values of these coordinates are identical, indicating that a closed loop was flown, the data for that segment are ignored, and "LAST SEGMENT THROWN OUT" is printed on-line, unless the leg contains only one segment.

If the leg contains only one segment which is a closed loop, subroutine ANGLE is called. In this case ANGLE reads an angle value from the on-line card reader and calls subroutine TRANS, which performs conversions of the data to earth coordinates. Control is then returned to MAIN, which causes subroutines LLOUT and POINTS to be executed, which provide outputs of print and plot data. Control is then returned to the instructions in MAIN, and data are again read from the input tape.

Normally, however, the two documentation points will not indicate a closed loop. With the use of the coordinates of the two checkpoints, the azimuth, or angle from true north, of the line joining the two points is calculated when MAIN calls subroutine ANGLE.

With the use of the same two coordinates, the distance between them is calculated by subroutine DIST. Once these values are calculated, they are available for use by MAIN and any subroutine.

The difference between the distance computed by DIST and the absolute difference between the across-track values at the two documentation points is examined. If the difference is greater than DIST, an error condition is assumed by MAIN. "INITIAL XT IN ERROR" is printed on-line. The title card is passed through the on-line card reader, and processing of the current leg no longer continues. At this time control is returned to that part of MAIN which reads the input tape.

If the initial across-track value does not result in an error condition, subroutine CORCVT is entered and executed. CORCVT performs the Doppler corrections and converts the position data to earth coordinates.

The preceding process continues until all segments of the leg have been considered. If all the observation data have been used but unused ground data remain, MAIN prints on-line, "POSSIBLE ERROR, NOT ALL GROUND DATA USED." If all ground data are used but unused observation data are detected, "POSSIBLE ERROR, NOT ALL OBSERVATION DATA USED" is printed on-line. In both cases the computer halts, with 52525₈ displayed on the computer console. Depressing the START button causes the entire leg to be ignored. The title card is passed through the on-line card reader, and control returns to the beginning of MAIN, which reads from the input tape.

If exact coincidence is obtained between the ground data and the observation data, subroutines LLOUT and POINTS are entered, in which the corrected and converted data are written on the print output tape and the data are converted to inputs for the plotter. The plot data are written on magnetic tape and, after processing is complete, are punched onto IBM cards.

Control is transferred to the beginning of MAIN, where new data are read from the input tape. Observation data for successive legs are read and processed until an END card appears, at which time the job is terminated.

Figure 2.4 shows an example of the on-line print-out function of the monitor program. Survey data were chosen in such a manner as to test the response of the monitor under several rejection criteria and with known, correct data. During the processing run the monitor informs the data analyst as to the acceptance or rejection of each leg of survey data. In addition, if a group of data is rejected, the reason for such action is recorded.

2.5.4 Subroutines

As shown in Fig. 2.2 and as discussed in Sec. 2.5.3, the body of the operations performed on the data is accomplished by MAIN in calling the various subroutines. A description of the service discharged by the individual subroutines will be given in the order of their summons as follows:

(a) *RJECT1 through RJECT6*. Subroutines RJECT1 through RJECT6 are discussed as a group because of their common function of removing unusable or erroneous observation data before final processing of the remaining good data.

RJECT1. This subroutine rejects all entries from the beginning of a leg until an along-track value of 10.00 ± 1.00 is found.

RJECT2. If three consecutive along-track and across-track values are found to be equal, all data from that point to the end of a leg are thrown out. In addition, all observations from the three identical position readings back to the most recent documentation points are also rejected.

RJECT3. Any data point that has a zero value for either along-track or across-track, but not both, is rejected.

RJECT4. A data entry is rejected if the change in radiation channel from the previous entry is greater than 4 and the following entry is not within ± 1 .

RJECT5. A data entry is rejected if the preceding and immediately following across-track direction indications are the same but are different from the entry itself.

RJECT6. A data observation is thrown out if the sum of the changes in across-track and along-track values from the previous observation does not fall within the limits of A and B, unless the same test can be met with the data point immediately following. (During normal reduction procedures, A = 0.05 and B = 0.50.)

Whenever a data point is rejected by any of these subroutines, a value of 1000 replaces the corresponding leg number accompanying that entry. Another subroutine later removes all entries of the leg in which 1000 appears in the leg number.

(b) *PACK.* This subroutine serves the purpose of removing all rejected-data entries that have been flagged by the insertion of 1000 in the leg number. *PACK* also labels all the documentation points occurring in the observation data by placing a zero in the corresponding leg number. Zero entries that precede or bracket documentation points are also removed. The remaining entries are packed into consecutive storage locations, and a count of the number of data points is established.

(c) *ANGLE.* This subroutine has two entries. The first entry is used if *MAIN* finds that a closed loop of one segment is to be processed. In this case, one card is read from the on-line card reader. The card contains the true azimuth corresponding to the flight reference line set into the Doppler during flying of the closed loop. After reading the angle, subroutine *ANGLE* calls subroutine *TRANS*, which converts the observation data into earth coordinates. Control is then returned to *ANGLE*, which in turn restores control to *MAIN*, the calling program.

The second entry calculates the azimuth, alpha, of a line joining two points for which the longitude and latitude coordinates are given. The equations and logic used in calculating the azimuth from north are as follows:

$$(\text{APDA})' = \alpha' + \frac{\Delta\alpha'}{2} \quad (2.1)$$

$$\text{DXON} = \text{XN} - \text{XO} \quad (2.2)$$

$$\text{DYON} = \text{YN} - \text{YO} \quad (2.3)$$

where *XO*, *YO* and *XN*, *YN* are the longitude and latitude of the two points. The signs associated with the quantities *DXON* and *DYON* when considered together determine the quadrant in which alpha lies. The correlations are shown in the following diagram.

DXON	DYON	Quad
-	+	1
-	-	2
+	-	3
+	+	4

Azimuth and quadrant determinations:

If *DXON* = 0 and *DYON* > 0, then *ALPHA* = 0 and *APDA* = 0.

If *DXON* = 0 and *DYON* < 0, then *ALPHA* = π and *APDA* = π .

If *DXON* < 0 and *DYON* = 0, then *APDA* = $\pi/2$ and *ALPHA* = *APDA* + (*DXON*/2) sin (*YO*).

If *DXON* > 0 and *DYON* = 0, then *APDA* = $3\pi/2$ and *ALPHA* = *APDA* + (*DXON*/2) sin (*YO*).

If *DXON* \neq 0 and *DYON* \neq 0, then the machine sets

$$(\text{APDA})' = \tan^{-1} \left[1.00432 \left| \frac{\text{DXON} \cos (\text{YO} + \text{DYON}/2)}{\text{DYON} \cos (\text{DXON}/2)} \right| \right] \quad (2.4)$$

For the conditions governing Eq. 2.4:

Quad 1: $\text{DXON} < 0$, $\text{DYON} > 0$, and $\text{APDA} = (\text{APDA})'$.

Quad 2: $\text{DXON} < 0$, $\text{DYON} < 0$, and $\text{APDA} = \pi - (\text{APDA})'$.

Quad 3: $\text{DXON} > 0$, $\text{DYON} < 0$, and $\text{APDA} = \pi + (\text{APDA})'$.

Quad 4: $\text{DXON} > 0$, $\text{DYON} > 0$, and $\text{APDA} = 2\pi - (\text{APDA})'$.

Finally the computer finds ALPHA from

$$\text{ALPHA} = \text{APDA} + \frac{\text{DXON}}{2} \sin \left(\text{YO} + \frac{\text{DYON}}{2} \right)$$

After performing these calculations, subroutine ANGLE makes the quantities ALPHA and APDA available for future use by the other subroutines.

(d) *TRANS*. When a closed loop of one segment is to be processed, there is no information upon which to perform the Doppler corrections. Thus, with the use of the angle ALPHA which is read by subroutine ANGLE when this special condition is detected, TRANS converts the Doppler position data directly to earth coordinates by use of the following formulas:

$$\text{YD} = \text{ATP} \cos (\text{ALPHA}) - \text{XTP} \sin (\text{ALPHA}) \quad (2.5)$$

$$\text{XD} = \text{XTP} \cos (\text{ALPHA}) + \text{ATP} \sin (\text{ALPHA}) \quad (2.6)$$

$$\text{YP} = \text{YO} + \frac{\text{YD}}{59.887} \quad (2.7)$$

$$\text{XP} = \text{XO} - \frac{\text{XD}}{60.147 \cos \text{YP}} \quad (2.8)$$

where ATP = indicated along-track value at data point P

XTP = indicated across-track value at data point P

XD = distance from XO to data point P along a north-south direction

YD = distance from YO to data point P along an east-west direction

XP = longitude of data point P

YP = latitude of data point P

XO = longitude of the starting and ending points of the loop

YO = latitude of the starting and ending points of the loop

(e) *DIST*. Subroutine DIST calculates the distance between two points for which the longitude and latitude coordinates are given. The equations and logic used in computing the distance are as follows:

XO, YO and XN, YN are the longitude and latitude of the two points.

$$\text{DXON} = \text{XN} - \text{XO}$$

$$\text{DYON} = \text{YN} - \text{YO}$$

If $\text{DXON} = 0$ and $\text{DYON} \neq 0$, then the distance DJC is

$$\text{DJC} = |59.887 \text{DYON} / \cos (\text{APDA})| \quad (2.9)$$

If $DXON \neq 0$ and $DYON = 0$, then

$$DJC = |60.147 DXON \cos (YO)/\sin (APDA)| \quad (2.10)$$

If $DXON \neq 0$ and $DYON \neq 0$, then

$$DJC = |59.887 DYON \cos (DXON/2)/\cos (APDA)| \quad (2.11)$$

Control is returned to the calling program with the distance, DJC, available for use in later calculations.

(f) *CORCVT*. The calculations performed by subroutine CORCVT apply corrections to the Doppler position data and convert the results to equivalent geocentric coordinates. The method followed has been explained in Sec. 1.6. The formulas used are repeated here. The transformations of the position data at all points P are

$$XTPC = XTP - XTO \quad (2.12)$$

$$ATPC = \frac{(ATP - ATO) (DJC \cos \beta)}{ATN - ATO} \quad (2.13)$$

where XTPC is the corrected across-track distance of *Pth* data point and ATPC is the corrected along-track distance of *Pth* data point.

If the first documentation point happens to be the initial point, IP, 10.00 is used for ATO, and the recorded across-track value is used for XTO.

If the angle ALPHA is the angle as computed by subroutine ANGLE, then the positions described by all points P can be expressed in terms of north-south distance and east-west distance from the initial checkpoint given by XO, YO by using the transformation

$$XD = XTPC \cos (\alpha - \beta) + ATPC \sin (\alpha - \beta) \quad (2.14)$$

$$YD = ATPC \cos (\alpha - \beta) - XTPC \sin (\alpha - \beta) \quad (2.15)$$

where XD is the distance of point P from XO, YO along east-west direction and YD is the distance of point P from XO, YO along north-south direction. If the longitude and latitude of the first point are XO, YO, the point P can be obtained in terms of earth coordinates by using the formulas

$$YP = YO + \frac{YD}{59.887} \quad (2.16)$$

$$XP = XO - \frac{XD}{60.147 \cos (YP)} \quad (2.17)$$

where XP is the longitude of point P and YP is the latitude of point P. When called, subroutine CORCVT performs the above computations on all data points occurring between two consecutive documentation points. When the calculations for those data are complete, control is returned to the calling program.

(g) *POINTS*. Subroutine POINTS converts longitude and latitude to plotter counts, assigns the central plot coordinates to each data point, and prepares a magnetic tape from which IBM cards are punched after a computer run. Each punched card contains the central plot coordinates, the longitude and latitude in plotter counts of four data points, the radiation levels of these points, and the two low-order digits of the corresponding leg number.

Occasionally two or more consecutive data points will indicate a single position to the nearest thousandth degree. If this occurs, the radiation-channel entries for those points is averaged and a single data point entered for plotting.

The values XO and YO mentioned in MAIN establish reference coordinates in longitude and latitude for laying out the plot grid quadrants. $DELTX$ and $DELTY$ specify the quadrant size in degrees longitude and latitude, respectively. Resulting plot quadrants will be bounded in intervals of $DELTX$ and $DELTY$ from a reference point XO, YO . Since it is usually convenient under normal production procedures to obtain quadrants that fall on even increments of degrees, XO and YO are commonly entered as zeros.

Plotter counts are calculated as

$$X = 13660 (XO - XP) \cos (YP - 1.0) \quad (2.18)$$

$$Y = 13748 (XP - YO) + 16 |XO - XP| \quad (2.19)$$

where X = plotter counts for longitude displacement from the assigned origin

Y = plotter counts for latitude displacement from the assigned origin

XO = longitude of the assigned origin

YO = latitude of the assigned origin

XP = longitude of the point to be plotted

YP = latitude of the point to be plotted

Equations 2.18 and 2.19 are based on plotting 9999 counts in 12.67 in.

(h) *OUTPUT*. Subroutine *OUTPUT* is included in the program mainly for checking subroutine 1. There are two entries to this routine. If sense switch 1 is down during processing, all input data are printed out after each rejection-test subroutine has been executed. An entry of 1000 in the leg number position indicates the entry has been rejected. If sense switch 2 is down during processing, a print-out occurs after all rejection tests have been executed. Only the acceptable observation data are printed, and documentation points are labeled. The outputs are written on tape 6, which must be printed after the computer run is complete. With proper sense-switch settings, either option may be selected independently, or both may be obtained. In the performing of production runs on the computer, these outputs are normally suppressed by operating with both sense switches 1 and 2 up.

(i) *LLOUT*. When subroutine *LLOUT* is entered, a card is read from the on-line card reader. Alphanumeric data are punched into the card, and these data are printed with the page headings on each page of the printed outputs for the leg being processed.

Subroutine *LLOUT* prepares and routes the longitude and latitude data to magnetic tape. The output tape, which is printed after all processing is terminated, is saved and can be used as an input to the computer through program *LLIN*.

(j) *LLIN*. A magnetic tape containing longitude and latitude data for each leg is written by the *ARMS-II* data-processing program, and so long as the magnetic tape is carefully stored the information written on it is permanently retained. It can be reprinted as often as desired and can also be read back into the computer for further processing.

Subroutine *LLIN* reads the master tape and converts the data of the selected legs to plotter information. *LLIN* reads the data from the master tape and executes subroutine *POINTS* previously described.

Additional data required by *LLIN* are the master-tape file numbers, leg numbers of the data to be converted, and parameters XO , YO , $DELTX$, and $DELTY$ for subroutine *POINTS*.

The master tape is produced by copying the magnetic tapes containing longitude and latitude data from each processing run onto a single tape. Each tape copied onto the master tape results in a file, the first being file 1, the second file 2, the third file 3, etc. Each file is normally composed of data for several legs. Therefore records are maintained showing file numbers and leg numbers on the master tape so that the information can be located by *LLIN*. The on-line print-out provided by the monitor of the data-processing program supplies the leg numbers of the legs that were successfully processed.

2.5.5 Instructions for Using LLIN

Five types of input cards are required by LLIN:

Type 1: This card is recognized by a 1 punched in column 1. A type 1 data card must always precede a type 2 data card.

Type 2: This card contains the parameters for subroutine POINTS. Columns 1 through 10 contain the value XO anywhere in the field, a decimal point being punched. Columns 11 through 20 contain YO. Columns 21 through 30 contain the value DELTX punched anywhere in the field, the decimal point being punched. Similarly, columns 31 through 40 contain the value DELTY. A type 2 card must be preceded by a type 1 card.

Type 3: This card is identified by a 2 in column 1. File numbers are punched in columns 2 through 5. The file number is right adjusted in the field, and no decimal point is punched.

Type 4: This card is punched with a 3 in column 1. The total number of leg numbers entered on the card is punched in columns 2 through 5. Up to 25 three-digit leg numbers can be entered in the remaining columns. The data in columns 2 through 5 must be right adjusted in the field, any decimal points being omitted. All three digits of each leg number are punched.

Type 5: This card is recognized by a 4 punched in column 1. Reading this card causes processing to stop with 77777₈ displayed on the console.

Reading of a type 1 card instructs the program to read a type 2 card immediately, which causes the values on the type 2 card to replace any previous corresponding values until changed again by another type 2 card. The type 3 card sets the file number until it is changed by another type 3 card. Once the parameters for subroutine POINTS and a file number have been specified, a type 4 card may be read. All legs on the type 4 card are processed, and another card is read. If the next two cards are types 1 and 2, the parameters for subroutine POINTS are changed. If the card is a type 3 card, the file number is changed. If the card is another type 4 card, the legs occurring on the card will be processed. Cards will continue to be read and processed until a type 5 card is read, which signifies the end of the computer run. It is necessary that parameters for POINTS and file number be specified before type 4 cards are read.

In the preparation of a computer run, the data cards are placed in the proper order behind the program deck, LLIN, and the program and data are loaded onto magnetic tape. This tape is assigned as tape 5 on the IBM-704 for processing. The master tape is assigned as tape 4. A utility tape, assigned as tape 8, is also required. Processing begins automatically when tape 5 is loaded into the IBM-704 and will continue until a tape 5 data record is read.

When processing is complete, tape 8 is removed and punched into IBM cards that can then be used for plotting.

Leg numbers on type 4 cards must occur in the same order as on the master tape for any one file. File numbers may occur in any order.

2.6 DATA-PLOTTING OPERATION

2.6.1 Plotter Description

The X-Y plotter employed for the finished map overlays is the model 3200 Dataplotter manufactured by Electronic Associates, Inc. The unit has had several small modifications to meet ARMS-II plotting requirements (see the appendix). Features of the plotter include the following:

1. Continuously variable gain settings in both X and Y directions
2. Continuously adjustable origin (0,0) location over the plotting surface
3. Removal of the origin from the plotting surface (parallax offset)
4. Card-reader input
5. Automatic or keyboard-controlled X and Y coordinate inputs
6. Automatic or keyboard-controlled numeric print-out
7. Error quoted at $\pm 0.05\%$ full scale ± 1 count

The data to be plotted consist of an X and a Y coordinate and the radiation level measured at that point. When the summary punch reads data locations from the cards, it also reads the radiation channels. Upon receiving the input information, the plotter crossarms move to the position corresponding to the coordinates and plot a symbol. The type of symbol designates the radiation sensitivity range used during data collection. High sensitivity is shown by a triangle (Δ) and low sensitivity by a square (\square). The overall height of the symbols is 0.060 in., and the center coincides with the location of the coordinate information. After plotting the position, the plotter crossarms automatically step $\frac{1}{8}$ in. to the right and plot the tens digit of the radiation channel; they then step another $\frac{1}{8}$ in. and plot the unit digit. Hence a completed overlay data point consists of three print operations. The plotter will plot about 26 completed data points per minute, depending on the distance the crossarms must move between points.

The print head drives a phenolic symbol wheel that contains 12 positions, i.e., 0 to 9, the triangle, and the square. Radiation data that are read from the cards are placed in temporary storage in the plotter until called by the plotting sequence switch. From storage they are routed to the print head, and the storage locations are cleared for entry of the next data. The print head positions the symbol wheel according to the logic signal and prints the information through a carbon-backed paper tape.

2.6.2 Plotter Input Cards

Figure 2.5 shows a typical plotter input card containing information describing four data points. Additional information is entered on the card to facilitate several types of sorting. Card columns 1 through 13 contain the longitude and latitude in thousandths of a degree of the map position which serves as plot origin for the data points contained on the card. The tens and unit digits of the survey leg numbers are punched in columns 78 and 79. These two columns as well as the central coordinates permit card sorting and plotting on the basis of two criteria. All data points associated with a particular leg number may not be plotted with reference to the same set of central coordinates. Therefore the card entries of central coordinates, leg number, and radiation channel allow a wide latitude of selection in sorting and plotting the data.

Columns 1 through 13, 78, 79, and 80 are not wired into the card-reader patch board. Since the IBM-523 summary punch is a parallel reading device, only one data point is read from the card as it passes through the machine. The patch-board wiring determines which card field generates the plotter input signals. To save time and to minimize the probability of introducing wiring errors, four patch boards are on hand, each of which is wired for a particular field. Hence all the points can be plotted by simply changing boards and rerunning the cards through the reader. The information shown on the card in Fig. 2.5 can be described briefly as follows:

1. The central coordinates are longitude 81.750° and latitude 38.335° .
2. The field 2 plotter coordinates are $X = -2624$ and $Y = +1253$.
3. The field 2 radiation level is $\Delta 06$, where $\Delta 06$ represents a radiation level of 500 to 600 counts/sec on the high-sensitivity range.

Fields 3, 4, and 5 represent similar information for the next three data points. A punch in row 11 represents a minus sign on the plotter X-Y coordinates, and a blank or an unpunched sign column denotes a positive number. A punch in row 12 of the symbol column is decoded as the high-sensitivity detection range, and a punch in row 11 in the symbol column is the low-sensitivity range.

2.6.3 Patch-board Wiring

The patch boards required to link the IBM-523 output to the Dataplotter input are the standard boards associated with the IBM-523. As mentioned, four patch boards are on file in the ARMS-II laboratory to select data from any of the four data fields on the cards. The output terminal numbers on the board correspond to the numbers of the card columns except that the signs of the X-Y plotter coordinates are picked up as a split-column connection with the X and Y coordinates thousand figure. The plotter input terminals on the patch board are designated as

“Total EXIT, Sections 2A through 6A.” Starting from the first hole at the left edge of the board, the plotter input signals are arranged in the following sequential pattern:

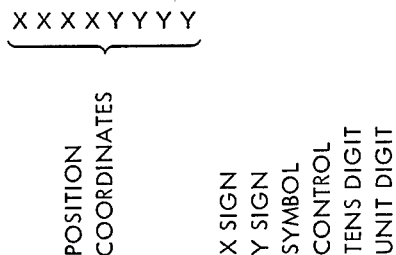

All patching that is to feed signals into the plotter must have the plotter input wires in the indicated locations and sequence.

2.7 EVALUATION OF THE ARMS-II AUTOMATIC DATA-PLOTTING SYSTEM

2.7.1 Test Results

Once the compilation of the machine program was completed and checked through the IBM-704 for workability, the question arose as to the validity of the indicated results. The following method was used to obtain the answer. Raw data were compiled with the intentional introduction of an accumulative error in both the along-track and the across-track distance measurements. A closed simulated flight path was constructed which followed U. S. Highway 101 from Buellton, Calif., to Santa Maria, Calif., then from Santa Maria south over Highway 1, and, finally, east following Highway 150, closing over the initial point at Buellton. The total path was between 50 and 60 miles and was quite irregular. Doppler position information was prepared in relation to a northwesterly course for points that corresponded to road intersections, railroad crossings, etc., along the proposed route. IBM cards were then made up containing the position data with the injected errors and processed through the IBM-704 computer. The output data were plotted on a transparency at the nominal 1 mile per inch map scale. Superposition of the plotted points over USGS quadrangle maps of the area disclosed in all cases that nearly exact coincidence was obtained between the plotted points and the corresponding map locations. The test indicates that the instrumental-error correction, longitude-latitude conversion, and plotter coordinate conversion programs are satisfactory. Comparison of the plotted results with the actual map locations of the landmarks shows that the inherent accuracy limitations, as discussed in Sec. 1.7, do not visibly affect the plotted results. Since the processing equipment cannot discriminate between compiled input data and data taken during actual survey flights, the program and presentation procedures are considered to be acceptable. Many independent tests have been made of the ability of the computer to perform subroutine 1—i.e., to reject or accept input data according to the rejection criteria—and in each case was found to function properly. The entire reduction and processing system adequately fulfills ARMS-II requirements.

2.7.2 Processing Time and Costs

Since the automatic data-reduction system has only recently been completed and tested, long-term operational time and costs are not available. The data from the Portsmouth, Ohio, survey area have been processed by this method so that preliminary information on the anticipated costs of using the machine system can be approximated. The data collected during one week of surveying covered 1566 nautical miles. Processing of these data required 34 min of IBM-704 machine time at \$200 per hour and 28 min of IBM-1401 machine time at \$55 per hour. Extending these figures to a full-size survey area of 10,000 line miles shows that 3.6 hr of IBM-704 time and 2.95 hr of IBM-1401 time are required. At the preceding quoted rates, machine costs are \$720 for the IBM-704 computer and \$162.50 for the IBM-1401 computer. These figures include the generation of a longitude-latitude and radiation-channel decimal

listing and the deck of plotter cards. The total cost is \$882.50, or about \$0.088 per traverse mile. The time and costs associated with the final plotting operation are in addition to this. In a full-size survey area, about 100,000 data points are to be expected. Plotting at the rate of 26 points per minute will require eight full 8-hr days to complete the data-point overlays. If setup time of the plotter for each pair of quadrants to be plotted is taken into account, a "round number" estimate of plotting time is about two weeks if each data point is recorded. If the behavior of the radiation levels is sufficiently consistent, experience may show that plotting every fourth data point will provide sufficient information for the construction of aeroradioactivity units. If this proves to be the case, plotting time will be shortened accordingly.

2.8 SUMMARY AND CONCLUSIONS

A program has been described which utilizes modern machine processing techniques to prepare systematically aerial survey data for presentation as map overlays. The degree of accuracy required during the processing is basically dependent upon that contained in the maps used during data collection and in data presentation. These are the standard USGS maps of 1:62,500 scale (nominal 1 mile per inch).

The program performs the following functions on the raw data:

1. Examines the data for erroneous entries
2. Performs corrections on the position data for errors that arise from instrumental imperfections
3. Converts the position coordinates to longitudes and latitudes for each data point
4. Associates the recorded radiation levels with the geocentric coordinates of each point
5. Converts the longitude and latitude of each point to coordinates that can be accepted by an X-Y plotter
6. Provides a capability of a decimal print-out of each data point in terms of longitude and latitude and the radiation level
7. Provides a capability of entering position data in terms of longitude and latitude and of converting to plotter coordinates
8. Incorporates an on-line diagnostic monitor print-out capability which informs the machine operator of the disposition of the data at all times during the processing operation

The system provides output data in three forms; each form is directed toward satisfying a different application or use of the completed survey information.

The first form is the decimal tabulation of the final data from which exact locations and radiation intensities can be selectively chosen; the second is the set of X-Y plotter cards from which the aircraft flight path and radiation levels can be graphically portrayed; and the third consists of the magnetic output tapes from the computer, which contain the survey-area identifications, the corrected position data, and radiation levels in a compact format suitable for permanent storage. The data on the magnetic tape can be reentered into the computer at any later time for further work if the need arises.

The hardware items required to process the data are divided between two locations. The apparatus needed to prepare the field data for entry into the computer and the equipment necessary to obtain the final presentation map overlays are situated in the ARMS-II laboratory. The computer and printers needed for the machine operations on the prepared data are rented at data-processing centers. The items used in the ARMS-II laboratory consist of a paper tape-to-card converter, a card sorter, a card reader, and the X-Y plotter. Units that are required at the computer center are the IBM-1401 computer, the IBM-704 computer, and the IBM-407 lister. Although the present magnitude of the ARMS-II work load does not justify the acquisition of the complete hardware requirements, the system as employed does permit retaining the desired degree of control on the data.

Previously the data were manually corrected and plotted. However, the effort associated with reducing the enormous number of data points generated during survey operations dictated that only locations showing significant variations or changes in radiation intensities or positions where the aircraft flight pattern changed be plotted. Thus the position-resolving capability of the Doppler navigation system could not be fully realized. With the present machine method

of data reduction, every acceptable data location is processed and plotted. Consequently the aeroradioactivity units constructed on the plotted overlays contain a corresponding degree of increased accuracy. Moreover, since the data are processed in groups every several weeks during survey activities, reduction and plotting of the data will be completed within seven or eight days after completion of flight activities in an area.

The reduction and processing system is not limited to the collection of terrestrial radiation data as the sampled, unknown quantity. The system can readily be adapted in fields of geomagnetic measurements, barometric graphing, cloud tracking, aerial gravimetric measurements, trajectories, and photographic mapping, to name but a few. The successful innovation of a system that will immediately provide aerial plots of airborne measurements possesses a high potential of possible applications. The work described in this report points out that, with the basic corrective logic successfully proved, the problems arising from adaptations to other measurements will be largely concerned with hardware and signal matings.

APPENDIX

In order that the effort expended during the pursuit of the present project can be presented more advantageously to agencies with an interest in the field, the compiled FORTRAN program for the ARMS-II data-reduction systems is considered to be a necessary part of the report. The following section is a reproduction of the IBM-407 listing of the program. The storage channels used during the operation of MAIN and each subroutine have been omitted. They are available if the need arises.

Photographs of the processing equipment and facilities used in the ARMS-II laboratory (Figs. 1 to 4) are included in this appendix.

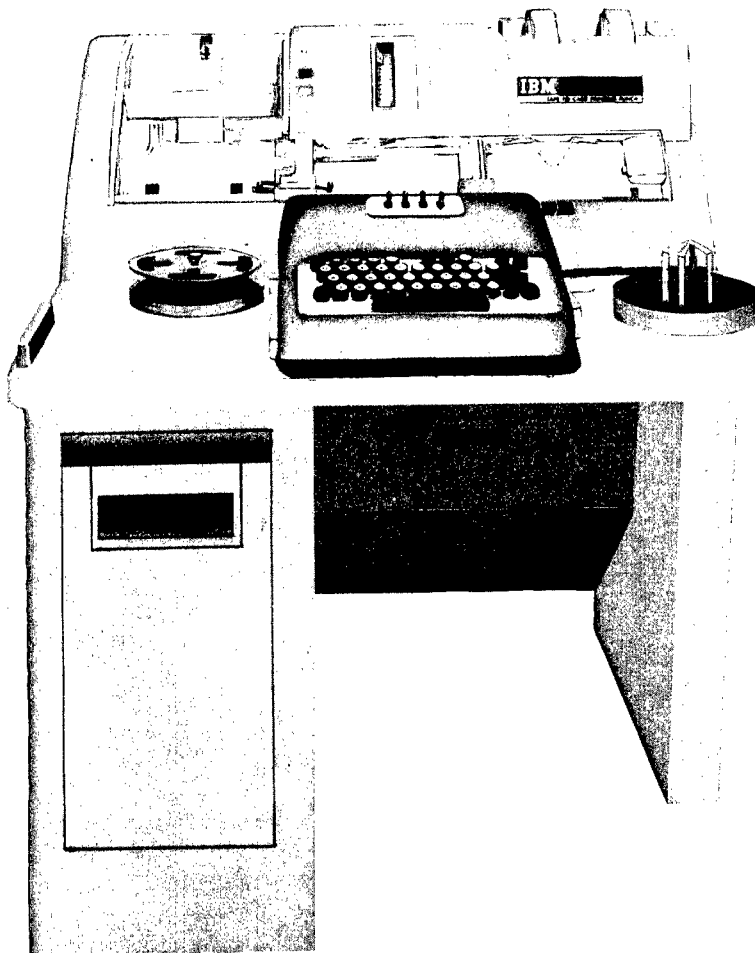

Fig. A.1—The 047 tape-to-card converter.

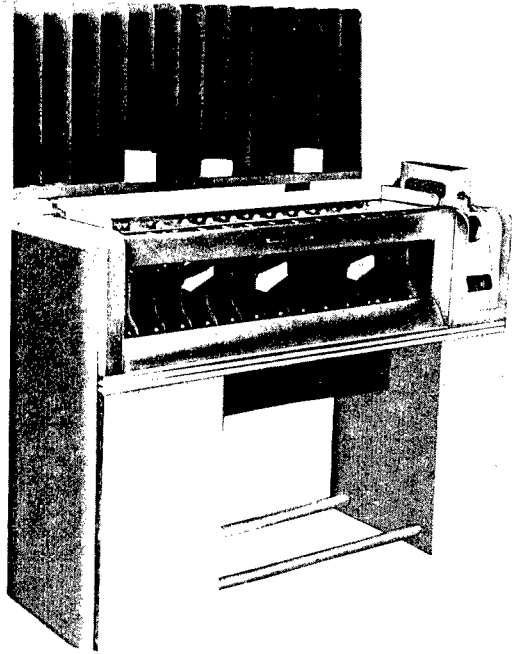

Fig. A.2—The IBM 082 card sorter.

Fig. A.3—The IBM 523 summary punch.

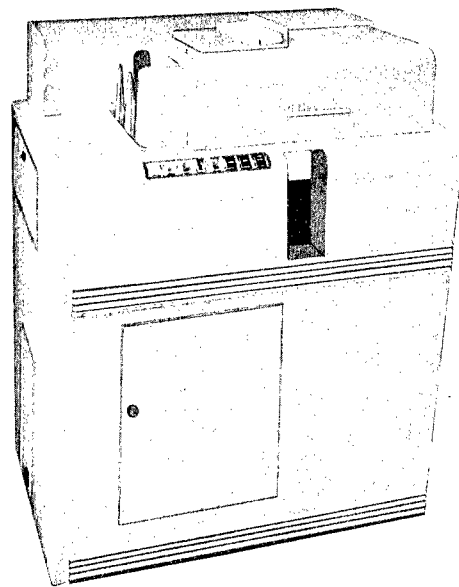
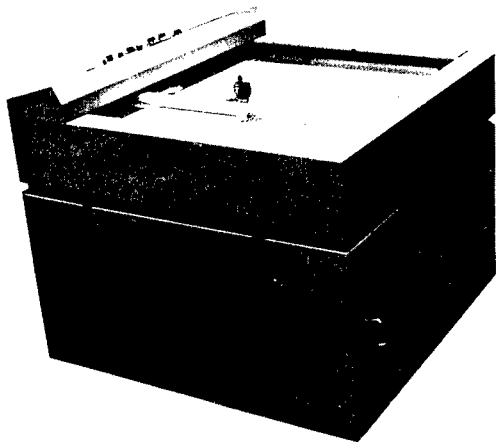

Fig. A.4—Electronic Associates, Inc., model 32 dataplotter.



IBM-407 LISTING

```

*ID  X1572616      JAS FA      J. SWANSON, EGG.      MAIN
*    FORTRAN
C    AIR RADIOLOGICAL MEASUREMENT SURVEY DATA PROCESSING PROGRAM. SWAN.
C    MAIN MONITOR.
      DIMENSION ISEG(4000),IRCH(4000),AT(4000),XT(4000),IRL(4000),
1    ISENS(4000),X(20),Y(20)
      COMMON ISEG,IRCH,AT,XT,IRL,ISENS,X,Y,AT1,XT1,AT2,XT2,XG,YG,DELTX,
1    DELTY,ALPHA,APDA,DJC
      COMMON INDXC
10   FLAG1=0.0
      I=1
20   IP4=I+4
      READ INPUT TAPE 5, 1000, ((ISEG(J),IRCH(J),AT(J),XT(J),IRL(J),
1    ISENS(J),J=1,IP4),IC)
1000 FORMAT (5(I3,I2,F4.2,F3.2,2I1),I2)
      IF (IC) 40,60,50
40   PRINT 1500
1500 FORMAT (12HOEND OF JOB.,//)
      PAUSE 77777
      GO TO 10
50   READ INPUT TAPE 5, 2000, (A,B,XG,YG,DELTX,DELTY)
2000 FORMAT (6F10.5)
      INDXC=0
      GO TO 10
60   IF(FLAG1) 80,70,80
70   ISEGT=ISEG
      PRINT 3000,(ISEGT)
3000 FORMAT (5HOLEG ,I3,1H.)
      FLAG1=1.0
80   DO 110 J=1,IP4
      IF (ISEG(J)) 90,110,90
90   IF (ISEG(J)-ISEGT) 100,110,100
100  IF (IRCH(J)-99) 120,110,120
110  CONTINUE
      I=IP4+1
      GO TO 20
C    ALL CURRENT OBSERVATION DATA HAS BEEN READ. BEGIN PROCESSING.
120  ICNT=J
      CALL RJECT1(ICNT)
      IF (SENSE SWITCH 1) 130,140
130  CALL OUTPUT (ICNT,ISEGT,1)
140  CALL RJECT2 (ICNT,IRTRN)
      IF (SENSE SWITCH 1) 150,160
150  CALL OUTPUT (ICNT,ISEGT,1)
160  GO TO (170,280),IRTRN
170  CALL RJECT3 (ICNT)
      IF (SENSE SWITCH 1) 180,190
180  CALL OUTPUT (ICNT,ISEGT,1)
190  CALL RJECT4 (ICNT)
      IF (SENSE SWITCH 1) 200,210
200  CALL OUTPUT (ICNT,ISEGT,1)
210  CALL RJECT5 (ICNT)
      IF (SENSE SWITCH 1) 220,230
220  CALL OUTPUT (ICNT,ISEGT,1)

```

```

230 CALL RJECT6 (ICNT,A,B)
    IF (SENSE SWITCH 1) 240,250
240 CALL OUTPUT (ICNT,ISEGT,1)
250 IF (SENSE SWITCH 2) 260,270
260 CALL OUTPUT (ICNT,ISEGT,2)
270 CALL PACK (ICNT,JCNT)
    IF (JCNT-15) 280,280,320
280 PRINT 4000
4000 FORMAT (37H REJECTED, LESS THAN 15 OBSERVATIONS.)
290 FLAG1=0.0
    I=1
    IF (ICNT-IP4) 300,300,20
300 DO 310 J=ICNT,IP4
    ISEG(I)=ISEG(J)
    IRCH(I)=IRCH(J)
    AT(I)=AT(J)
    XT(I)=XT(J)
    IRL(I)=IRL(J)
    ISENS(I)=ISENS(J)
310 I=I+1
    IP4=I-1
    I=1
    GO TO 70
320 READ 5000. (LEGN,N,XTINIT)
5000 FORMAT (I3.7X12.8XF10.5)
    READ 5300. (X(I),Y(I);I=1,N)
5300 FORMAT (2F10.5)
    IF (LEGN-ISEGT) 330,350,330
330 PRINT 5500. (LEGN)
5500 FORMAT (18H GROUND DATA, LEG ,I3.1H,16HOUT OF SEQUENCE.)
    PAUSE
    IF (SENSE SWITCH 6) 530,40
350 AT1=10.0
    XT1=XTINIT
360 J=2
    I=1
370 IHOLD=I
380 IF (ISEG(I)) 390,410,390
390 I=I+1
    IF (I-JCNT) 380,380,400
400 I=I-1
410 IF (X(J)-X(J-1)) 470,420,470
420 IF (Y(J)-Y(J-1)) 470,430,470
430 IF (N-2) 470,470,440
440 IF (J-N) 460,450,450
450 JCNT=IHOLD-1
    PRINT 6000
6000 FORMAT (25H LAST SEGMENT THROWN OUT.)
    GO TO 570
460 AT1=AT(I)
    XT1=XT(I)
    J=J+1
    I=I+1
    GO TO 380
470 CALL ANGLE (J,JCNT,IRTRN)
    GO TO(480,570), IRTRN
480 CALL DIST (J)
    AT2=AT(I)
    XT2=XT(I)
    IF (ABS(XT2-XT1)-DJC) 482,481,481
481 PRINT 6500
6500 FORMAT (21H INITIAL XT IN ERROR.)
    GO TO 530
482 CALL CORCVT (IHOLD,I,J)
490 J=J+1
    I=I+1
    IF (J-N) 500,500,540

```

```

500 IF (I-JCNT-1) 370,510,510
510 PRINT 7000
7000 FORMAT (42H POSSIBLE ERROR. NOT ALL GROUND DATA USED.)
520 PAUSE
    IF(SENSE SWITCH 6) 560,530
530 READ 8000
8000 FORMAT (1X)
    GO TO 290
540 IF (I-JCNT-1) 550,570,570
550 PRINT 9000
9000 FORMAT (47H POSSIBLE ERROR. NOT ALL OBSERVATION DATA USED.)
    GO TO 520
560 JCNT=I-1
570 CALL LLOUT (JCNT,ISEGT)
    CALL POINTS (JCNT)
    PRINT 9500
9500 FORMAT (19H NO ERROR DETECTED.)
    GO TO 290
    END(1,1,0,0,0)

*ID X1572616 JAS FA J. SWANSON, EGG. RJECT1
* FORTRAN
C REJECTION TEST. TIME LAG AT DOPPLER TRANSFER. REJECTS ALONG TRACK
C ENTRIES UNTIL ALONG TRACK VALUE IS BETWEEN 9 AND 11.
SUBROUTINE RJECT1 (ICNT)
DIMENSION ISEG(4000),IRCH(4000),AT(4000),XT(4000),IRL(4000),
XISENS(4000)
COMMON ISEG,IRCH,AT,XT,IRL,ISENS
IMASK=1000
DO 35 I=1,ICNT
    IF(AT(I)-11.0) 10,10,20
10 IF(AT(I)-9.0) 20,40,40
20 IF(ISEG(I)) 30,35,30
30 ISEG(I)=IMASK
35 CONTINUE
40 RETURN
    END(1,1,0,0,0)

*ID X1572616 JAS FA J. SWANSON, EGG. RJECT2
* FORTRAN
C REJECTION TEST. DOPPLER IM MEMORY OR STANDBY-PARITY LOCKUP.
SUBROUTINE RJECT2 (ICNT,IRTRN)
DIMENSION ISEG(4000),IRCH(4000),AT(4000),XT(4000),IRL(4000),
XISENS(4000)
COMMON ISEG,IRCH,AT,XT,IRL,ISENS
IMASK=1000
10 I=1
20 IF(ISEG(I)-IMASK) 50,30,50
30 I=I+1
40 IF(I-ICNT+1) 20,250,250
50 J=I+1
60 IF(ISEG(J)-IMASK) 80,70,80
70 J=J+1
    IF(J-ICNT) 60,250,250
80 IF(AT(I)) 110,90,110
90 IF(XT(I)) 110,100,110
100 I=J
    GO TO 40
110 IF(AT(I)-AT(J)) 100,120,100
120 IF(XT(I)-XT(J)) 100,130,100
130 K=J+1
140 IF(ISEG(K)-IMASK) 160,150,160
150 K=K+1
    IF(K-ICNT) 140,140,250
160 IF(AT(J)-AT(K)) 180,170,180
170 IF(XT(J)-XT(K)) 180,190,180
180 I=K
    GO TO 40

```

```

190 DO 200 J=1,ICNT
200 ISEG(J)=IMASK
210 I=I-1
    IF (I) 260,260,220
220 IF (ISEG(I)-IMASK) 230,210,230
230 IF (ISEG(I)) 240,270,240
240 ISEG(I+1)=IMASK
    GO TO 210
250 IRTN=1
    RETURN
260 !RTN=2
    RETURN

270 J=I+1
275 I=I-1
    IF (I) 260,260,280
280 IF (ISEG(I)) 290,275,290
290 IF (ISEG(I-1)) 250,300,250
300 ISEG(J)=IMASK
    GO TO 250
    END(1,1,0,0,0)

*ID X1572616 JAS FA J. SWANSON, EGG. RJECT3
* FORTRAN
C REJECTION TEST. UNINTENTIONAL ALONG TRACK AND ACROSS TRACK ZEROS.
SUBROUTINE RJECT3 (ICNT)
DIMENSION ISEG(4000),IRCH(4000),AT(4000),XT(4000),IRL(4000),
XISFNS(4000)
COMMON ISEG,IRCH,AT,XT,IRL,ISENS
IMASK=1000
10 DO 60 I=1,ICNT
    IF (ISEG(I)-IMASK) 20,60,20
20 IF (AT(I)) 40,30,40
30 IF (XT(I)) 50,55,50
40 IF (XT(I)) 60,50,60
50 ISEG(I)=IMASK
    GO TO 60
55 IF (ISEG(I)) 50,60,50
60 CONTINUE
    RETURN
    END(1,1,0,0,0)

*ID X1572616 JAS FA J. SWANSON, EGG. RJECT4
* FORTRAN
C REJECTION TEST. ERRONEOUS RADIATION CHANNEL ENTRIES.
SUBROUTINE RJECT4 (ICNT)
DIMENSION ISEG(4000),IRCH(4000),AT(4000),XT(4000),IRL(4000),
XISENS(4000)
COMMON ISEG,IRCH,AT,XT,IRL,ISENS
IMASK=1000
DO 30 I=1,ICNT
    IF (ISEG(I)-IMASK) 10,30,10
10 IF (IRCH(I)-20) 30,30,20
20 ISEG(I)=IMASK
30 CONTINUE
    I=1
40 IF (ISEG(I)-IMASK) 70,50,70
50 I=I+1
60 IF (I-ICNT+1) 40,210,210
70 IF (ISEG(I)) 80,50,80
80 J=I+1
90 IF (ISEG(J)-IMASK) 110,100,110
100 J=J+1
    IF (J-ICNT) 90,210,210
110 IF (ISEG(J)) 120,100,120
120 IRCHD=XABSF(IRCH(I)-IRCH(J))
    IF (IRCHD-4) 130,130,140
130 I=J
    GO TO 60

```

```

140 K=J+1
150 IF (ISEG(K)-IMASK) 170,160,170
160 K=K+1
    IF (K-ICNT) 150,150,200
170 IF (ISEG(K)) 180,160,180
180 IRCHD=XABSF(IRCH(J)-IRCH(K))
    IF (IRCHD-1) 130,130,190
190 IF (ISENS(I)-ISENS(J)) 130,200,130
200 ISEG(J)=IMASK
    GO TO 100
210 RETURN
    END(1,1,0,0,0)

*ID X1572616 JAS FA J. SWANSON, EGG. RJECT5
* FORTRAN
SUBROUTINE RJECT5 (ICNT)
DIMENSION ISEG(4000),IRCH(4000),AT(4000),XT(4000),IRL(4000),
XISENS(4000)
COMMON ISEG,IRCH,AT,XT,IRL,ISENS
IMASK=1000
10 I=1
20 IF (ISEG(I)-IMASK) 50,30,50
30 I=I+1
40 IF (I-ICNT+1) 20,190,190
50 IF (ISEG(I)) 60,30,60
60 J=I+1
70 IF (ISEG(J)-IMASK) 90,80,90
80 J=J+1
    IF (J-ICNT) 70,190,190
90 IF (ISEG(J))100,80,100
100 IF (IRL(I)-IRL(J)) 120,110,120
110 I=J
    GO TO 40
120 K=J+1
130 IF (ISEG(K)-IMASK) 150,140,150
140 K=K+1
    IF (K-ICNT) 130,130,180
150 IF (ISEG(K)) 160,140,160
160 IF (IRL(J)-IRL(K)) 180,170,180
170 I=K
    GO TO 40
180 ISEG(J)=IMASK
    I=K
    GO TO 40
190 RETURN
    END(1,1,0,0,0)

*ID X1572616 JAS FA J. SWANSON, EGG. RJECT6
* FORTRAN
C REJECTION TEST. REJECTS ENTRIES NOT IN NORMAL SEQUENCE.
SUBROUTINE RJECT6 (ICNT,A,B)
DIMENSION ISEG(4000),IRCH(4000),AT(4000),XT(4000),IRL(4000),
XISENS(4000)
COMMON ISEG,IRCH,AT,XT,IRL,ISENS
DO 2 I=1,ICNT
    IF (IRL(I)-2) 1,2,2
1 XT(I)=-XT(I)
2 CONTINUE
IMASK=1000
10 I=1
20 IF (ISEG(I)-IMASK) 50,30,50
30 I=I+1
40 IF (I-ICNT) 20,220,220
50 IF (ISEG(I)) 60,30,60
60 K=I+1
70 IF (ISEG(K)-IMASK) 90,80,90
80 K=K+1
    IF (K-ICNT) 70,70,220

```

```

90 IF (ISEG(K)) 100,80,100
100 D=ABSF(AT(I)-AT(K))+ABSF(XT(I)-XT(K))
    IF (D-A) 210,110,110
110 IF (B-D) 130,120,120
120 I=K
    GO TO 40
130 J=K+1
140 IF (J-ICNT) 150,150,210
150 IF (ISEG(J)-IMASK) 170,160,170
160 J=J+1
    GO TO 140
170 IF (ISEG(J)) 180,160,180
180 D=ABSF(AT(J)-AT(K))+ABSF(XT(J)-XT(K))
    IF (D-A) 210,190,190
190 IF (B-D) 210,200,200
200 I=J
    GO TO 40
210 ISEG(K)=IMASK
    GO TO 60
220 RETURN
    END(1,1,0,0,0)
*ID X1572616 JAS FA J. SWANSON, EGG. PACK
* FORTRAN
C PACK GOOD OBSERVATIONS.
  SUBROUTINE PACK (ICNT,JCNT)
  DIMENSION ISEG(4000),IRCH(4000),AT(4000),XT(4000),IRL (4000),
  ISENS(4000)
  COMMON ISEG,IRCH,AT,XT,IRL,ISENS
  I=1
  J=1
  IMASK=1000
10 IF (ISEG(I)-IMASK) 30,20,30
20 I=I+1
  IF (I-ICNT) 10,10,100
30 IF (ISEG(I)) 40,50,40
40 ISEG(J)=ISEG(I)
  AT(J)=AT(I)
  XT(J)=XT(I)
  IRCH(J)=IRCH(I)
  ISENS(J)=ISENS(I)
  J=J+1
  GO TO 20
50 I=I+1
  IF (I-ICNT) 60,60,100
60 IF (ISEG(I)) 70,50,70
70 ISEG(J)=0
  AT(J)=AT(I)
  XT(J)=XT(I)
  IRCH(J)=IRCH(I)
  ISENS(J)=ISENS(I)
  J=J+1
80 I=I+1
  IF (I-ICNT) 90,90,100
90 IF (ISEG(I)) 10,80,10
100 JCNT=J-1
  RETURN
  END(1,1,0,0,0)
*ID X1572616 JAS FA J. SWANSON, EGG. ANGLE
* FORTRAN
C COMPUTE AZIMUTH DATA. (ALPHA, ALPHA+DELTA ALPHA/2).
  SUBROUTINE ANGLE (J,JCNT,IRTRN)
  DIMENSION ISEG(4000),IRCH(4000),AT(4000),XT(4000),IRL(4000),
  ISENS(4000),X(20),Y(20)
  COMMON ISEG,IRCH,AT,XT,IRL,ISENS,X,Y,AT1,XT1,AT2,XT2,XG,YG,DELTX,
  DELTY,ALPHA,APDA,DJC
  XN=X(J)

```

```

YN=Y(J)
XO=X(J-1)
YO=Y(J-1)
DXON=XN-XO
CALL CONVRT (DXON,Z,Z,3)
DYON=YN-YO
CALL CONVRT (DYON,Z,Z,3)
YOR=YO
YNR=YN
XOR=XO
XNR=XN
CALL CONVRT (YOR,Z,Z,3)
CALL CONVRT (YNR,Z,Z,3)
CALL CONVRT (XOR,Z,Z,3)
CALL CONVRT (XNR,Z,Z,3)
IF (DXON) 40,10,40
10 IF (DYON) 30,170,20
20 ALPHA=0.0
25 APDA=0.0
GO TO 155
30 ALPHA=3.1415927
APDA=ALPHA
GO TO 155
40 IF (DYON) 90,50,90
50 IF (DXON) 60,170,80
60 APDA=1.5707963
70 ALPHA=APDA+DXON*SINF(YOR)/2.0
GO TO 155
80 APDA=4.7123890
GO TO 70
90 Q=(DXON*COSF(YOR+DYON/2.0))/(DYON*COSF(DXON/2.0))
APDA=ATANF(1.0043200*ABSF(Q))
IF (DXON) 100,170,120
100 IF (DYON) 110,170,150
110 APDA=3.1415927-APDA
GO TO 150
120 IF (DYON) 140,170,130
130 APDA=6.2831853-APDA
GO TO 150
140 APDA=3.1415927+APDA
150 ALPHA=APDA+DXON*SINF(YOR+DYON/2.0)/2.0
155 ITRN=1
160 RETURN
170 READ 1000, (ALPHA)
1000 FORMAT (F10.4)
DO 180 I=1,JCNT
180 AT(I)=AT(I)-10.0
CALL TRANS (I,JCNT,ALPHA,XO,YO)
ITRN=2
GO TO 160
END(1,1,0,0,0)
*10 X1572616 JAS FA J. SWANSON, EGG. TRANS
*
* FORTRAN
*
* CONVERSION AND POSITION CALCULATIONS FOR DEGENERATE CASES.
* SUBROUTINE TRANS (IHOLD,I,ALPHA,XO,YO)
* DIMENSION ISEG(4000),IRCH(4000),AT(4000),XT(4000),IRL(4000),
* XISENS(4000)
* COMMON ISEG,IRCH,AT,XT,IRL,ISENS
* DO 10 J=IHOLD,I
* YPP=(AT(J)*COSF(ALPHA))-(XT(J)*SINF(ALPHA))
* XPP=(XT(J)*COSF(ALPHA))+(AT(J)*SINF(ALPHA))
* AT(J)=YO+(YPP/59.887)
* YPP=AT(J)
* CALL CONVRT (YPP,Z,Z,3)
10 XT(J)=XO-(XPP/(60.147*COSF(YPP)))
RETURN
END(1,1,0,0,0)

```

```

*ID X1572616 JAS FA J. SWANSON. EGG. DIST
* FORTRAN
C DISTANCE CALCULATION FOR DOCUMENTATION POINT.
SUBROUTINE DIST (J)
DIMENSION ISEG(4000),IRCH(4000),AT(4000),XT(4000),IRL(4000),
IISENS(4000),X(20),Y(20)
COMMON ISEG,IRCH,AT,XT,IRL,ISENS,X,Y,AT1,XT1,AT2,XT2,XG,YG,DELTX,
IDELTY,ALPHA,APDA,DJC
XJ=X(J)
YJ=Y(J)
XO=X(J-1)
YO=Y(J-1)
DXOJ=XJ-XO
DYOJ=YJ-YO
IF(DXOJ) 20,5,20
5 IF(DYOJ) 10,50,10
10 DJC=ABSF(59.887*DYOJ/COSF(APDA))
GO TO 45
20 IF (DYOJ) 40,30,40
30 YOR=YO
CALL CONVRT (YOR,Z,Z,3)
DJC=ABSF(60.147*DXOJ*COSF(YOR)/SINF(APDA))
GO TO 45
40 CALL CONVRT (DXOJ,Z,Z,3)
DJC=ABSF(59.887*DYOJ*COSF(DXOJ/2.0)/COSF(APDA))
45 ITRN=1
50 RETURN
60 ITRN=2
GO TO 50
END(1,1,0,0,0)

```

```

*ID X1572616 JAS FA J. SWANSON. EGG. CORCVT
* FORTRAN
C ALONG AND ACROSS TRACK CORRECTIONS.
C LATITUDE AND LONGITUDE CONVERSIONS.
SUBROUTINE CORCVT (IHOLD,I,J)
DIMENSION ISEG(4000),IRCH(4000),AT(4000),XT(4000),IRL(4000),
IISENS(4000),X(20),Y(20)
COMMON ISEG,IRCH,AT,XT,IRL,ISENS,X,Y,AT1,XT1,AT2,XT2,XG,YG,DELTX,
IDELTY,ALPHA,APDA,DJC
SGR1=(XT2-XT1)
GOOP=SQRTF((DJC*DJC)-(SGR1*SGR1))
BETA=ATANF(ABSF(SGR1/GOOP))
IF (SGR1) 5,5,3
3 IF (AT2-AT1) 4,8,8
4 BETA=3.1415927-BETA
GO TO 8
5 IF (AT2-AT1) 6,6,7
6 BETA=3.1415927+BETA
GO TO 8
7 BETA=6.2831853-BETA
8 RATIO=(DJC*COSF(BETA))/(AT2-AT1)
ZIN=SINF(ALPHA-BETA)
ZOS=COSF(ALPHA-BETA)
DC 10 K=IHOLD,I
AT1PC=(AT(K)-AT1)*RATIO
XTS2=(XT(K)-XT1)
YPP=(AT1PC*ZOS)-(XTS2*ZIN)
XPP=(XTS2*ZOS)+(AT1PC*ZIN)
AT(K)=Y(J-1)+(YPP/59.887)
YPP=AT(K)
CALL CONVRT (YPP,Z,Z,3)
10 XT(K)=X(J-1)-(XPP/(60.147*COSF(YPP)))
AT1=AT2
XT1=XT2
RETURN
END(1,1,0,0,0)

```

```

*ID  X1572616      JAS FA      J. SWANSON, EGG.      POINTS
*    FORTRAN
C    PLOTTING ROUTINE. FIRST TRY.
      SUBROUTINE POINTS (JCNT)
      DIMENSION COORDX(100),COORDY(100)
      DIMENSION ISEG(4000),IRCH(4000),AT(4000),XT(4000),IRL(4000),
1 ISENS(4000),X(20),Y(20)
      DIMENSION SIGN(3),BUFAX(4),BUFAY(4),BUFS(4),IBUFR(4),IBUFC(4)
      COMMON ISEG,IRCH,AT,XT,IRL,ISENS,X,Y,AT1,XT1,AT2,XT2,XG,YG,DELTX,
1 DELTY,ALPHA,APDA,DJC
      COMMON INDXC
1000 FORMAT (0PF7.3,0PF6.3,4(1PF6.3,1PF6.3,A1,I2,I1),I2)
      INDXC=0
      CALL HOLLER (3,18H+      -      ,SIGN)
      DO 10 I=1,JCNT
      AT(I)= INTF((AT(I)+.0005)*1000.0)
10 XT(I)=INTF ((XT(I)+.0005)*1000.0)
      NSEG = ISEG(I)
      J=1
      I=1
20 AK=1.0
      AVE=IRCH(I)
30 IF (AT(I)-AT(I+1)) 60,40,60
40 IF (XT(I)-XT(I+1)) 60,50,60
50 AK=AK+1.0
      AVE1=IRCH(I+1)
      AVE=AVE+AVE1
      I=I+1
      IF (I-JCNT) 30,60,60
60 IRCH(J)=AVE/AK
70 AT(J)=AT(I)
      XT(J)=XT(I)
      ISENS(J)=ISENS(I)
      J=J+1
      I=I+1
      IF (I-JCNT)20,80,90
80 IRCH(J)=IRCH(I)
      GO TO 70
90 JCNT=J-1
      DO 100 I=1,JCNT
      AT(I)=AT(I)/1000.0
      XT(I)=XT(I)/1000.0
      XO=INTF((XT(I)-XG)/DELTX)
      YO=INTF((AT(I)-YG)/DELTY)
      XO=XG+(DELTX*XO)+(DELTX/2.0)
      YO=YG+(DELTY*YO)+(DELTY/2.0)
      IF (INDXC) 91,95,91
91 DO 94 K=1,INDXC
      IF (XO-COORDX(K)) 94,92,94
92 IF (YO-COORDY(K)) 94,93,94
93 ISEG(I)=K
      GO TO 96
94 CONTINUE
95 INDXC=INDXC+1
      COORDX(INDXC)=XO
      COORDY(INDXC)=YO
      ISEG(I)=INDXC
96 YP=AT(I)-1.0
      XP=XT(I)
      CALL CONVRT (YP,Z,Z,3)
      XT(I)=1.366*(XO-XP)*COSF(YP)
100 AT(I)=1.3748*(AT(I)-YO)+.0016*ABSF(XO-XP)
      K=1
      DO 190 I=1,INDXC
      DO 160 J=1,JCNT
      IF (ISEG(J)-I) 160,110,160

```

```

110 BUFAX(K)=XT(J)
    BUFAY(K)=AT(J)
    IBUFR(K)=IRCH(J)+100
    IBUFC(K)=4
    IF (ISENS(I)-6) 120,130,130
120 BUFS(K)=SIGN(2)
    GO TO 140
130 BUFS(K)=SIGN(1)
140 K=K+1
    IF (K-5) 160,150,150
150 WRITE OUTPUT TAPE 8,1000,(COORDX(I),COORDY(I),(BUFAX(L),BUFAY(L),
    IBUFS(L),IBUFR(L),IBUFC(L),L=1,4),NSEG)
    K=1
160 CONTINUE
    IF (K-1) 190,190,170
170 DO 180 L=K,4
    BUFAX(L)=0.0
    BUFAY(L)=0.0
    IBUFR(L)=100
    IBUFC(L)=0
180 BUFS(L)=SIGN(3)
    WRITE OUTPUT TAPE 8,1000,(COORDX(I),COORDY(I),(BUFAX(L),BUFAY(L),
    IBUFS(L),IBUFR(L),IBUFC(L),L=1,4),NSEG)
    K=1
190 CONTINUE
    RETURN
    END (1,1,0,0,0)

*ID X1572616 JAS FA J. SWANSON, EGG. OUTPUT
* FORTRAN
C INTERMEDIATE OUTPUT ROUTINES.
  SUBROUTINE OUTPUT (ICNT,ISEGT,IPICK)
    DIMENSION ISEG(4000),IRCH(4000),AT(4000),XT(4000),IRL(4000),
    IISENS(4000)
    COMMON ISEG,IRCH,AT,XT,IRL,ISENS
3000 FORMAT(8H SEG=14.7H RC=12.7H AT=F5.2.7H XT=F5.2.
    X7H RL=11.9H SENS=11)
4000 FORMAT (6H1ICNT=13)
5000 FORMAT (31H1REDUCED ARMS DATA FOR SEGMENT 13)
6000 FORMAT (20H0DOCUMENTATION POINT)
7000 FORMAT (1H0)
8000 FORMAT (11H RC=12.7H AT=F5.2.7H XT=F5.2.
    X7H RL=11.9H SENS=11)
    GO TO (10,20),IPICK
10 WRITE OUTPUT TAPE 6, 4000, ICNT
    WRITE OUTPUT TAPE 6, 3000, (ISEG(I),IRCH(I),AT(I),XT(I),IRL(I),
    IISENS(I), I=1,ICNT)
    RETURN
20 WRITE OUTPUT TAPE 6, 5000, (ISEGT)
    WRITE OUTPUT TAPE 6, 7000
    I=1
    IMASK=1000
30 IF (ISEG(I)-IMASK) 40,120,40
40 IF (ISEG(I)) 50,60,50
50 WRITE OUTPUT TAPE 6, 8000, (IRCH(I),AT(I),XT(I),IRL(I),ISENS(I))
    GO TO 120
60 WRITE OUTPUT TAPE 6, 6000
70 I=I+1
    IF (I-ICNT) 80,80,130
80 IF (ISEG(I)) 90,70,90
90 WRITE OUTPUT TAPE 6, 8000, (IRCH(I),AT(I),XT(I),IRL(I),ISENS(I))
    WRITE OUTPUT TAPE 6, 7000
100 I=I+1
    IF (I-ICNT) 110,110,130
110 IF (ISEG(I)) 30,100,30
120 I=I+1
    IF (I-ICNT) 30,30,130

```

```

130 RETURN
END(1,1,0,0,0)
*ID X1572616 JAS FA J. SWANSON, EGG. LLOUT
* FORTRAN
C FINAL PRESENTATION OUTPUTS.
SUBROUTINE LLOUT (JCNT,ISEGT)
DIMENSION ISEG(4000),IRCH(4000),AT(4000),XT(4000),IRL(4000),
1ISENS(4000)
COMMON ISEG,IRCH,AT,XT,IRL,ISENS
1000 FORMAT (1H1,99X5HPAGE 12,40X15)
2000 FORMAT (12H LOCATION 3A6/12H DATE 3A6/12H LEG 13//)
3000 FORMAT (3(12X4HLONG,7X3HLAT,5X2HRC,3X4HSENS))
3001 FORMAT (2(12X4HLONG,7X3HLAT,5X2HRC,3X4HSENS))
3002 FORMAT (12X4HLONG,7X3HLAT,5X2HRC,3X4HSENS)
DIMENSION IALP(4),ALP(6)
4000 FORMAT (3(6XA4,F7.3,4XF6.3,4X12,4XA3))
5000 FORMAT (6A6)
READ 5000, (ALP(I),I=1,6)
CALL HOLLER (4,24H DP HI LO ,IALP)
DO 30 I=1,JCNT
IF (ISEG(I)) 20,10,20
10 IRL(I)=IALP(1)
GO TO 30
20 IRL(I)=IALP(2)
30 CONTINUE
DO 36 I=1,JCNT
IF (ISENS(I)-6) 32,34,34
32 ISENS(I)=IALP(4)
GO TO 36
34 ISENS(I)=IALP(3)
36 CONTINUE
I=1
N=1
40 WRITE OUTPUT TAPE 6, 1000, (N)
WRITE OUTPUT TAPE 6, 2000, ((ALP(K),K=1,6),ISEGT)
IF (I-JCNT+44) 44,44,42
42 WRITE OUTPUT TAPE 6,3002
GO TO 49
44 IF (I-JCNT+88) 48,48,46
46 WRITE OUTPUT TAPE 6,3001
GO TO 49
48 WRITE OUTPUT TAPE 6,3000
49 L=1
50 IF(L-44) 70,70,60
60 N=N+1
I=I+88
IF (I-JCNT) 40,40,120
70 IF (I-JCNT) 80,80,120
80 IPLUS=I
IF (IPLUS-JCNT+44) 90,90,110
90 IPLUS=IPLUS+44
IF (IPLUS-JCNT+44) 100,100,110
100 IPLUS=IPLUS+44
110 WRITE OUTPUT TAPE 6, 4000, (IRL(M),XT(M),AT(M),IRCH(M),ISENS(M),
1M=I,IPLUS,44)
I=I+1
L=L+1
GO TO 50
120 DO 130 M=1,JCNT
IF (ISENS(M)-IALP(4)) 132,134,132
132 ISENS(M)=6
GO TO 136
134 ISENS(M)=5
136 CONTINUE
RETURN
END(1,1,0,0,0)

```

SUBROUTINE LLIN

```

* ID   X1572616   JAS FA   J. SWANSON, EGG.   PLOT FROM MASTER
*      FORTRAN
C      PROGRAM GENERATES PLOT DATA FROM MASTER FILES.
      DIMENSION ISEG(4000),IRCH(4000),AT(4000),XT(4000),IRL(4000),
1 ISENS(4000),X(20),Y(20)
      DIMENSION IALP(4),ALP(6)
      DIMENSION IBUFR(27)
      COMMON ISEG,IRCH,AT,XT,IRL,ISENS,X,Y,AT1,XT1,AT2,XT2,XG,YG,DELTX,
1 DELTY,ALPHA,APDA,DJC
      COMMON INDXC
1000   FORMAT (11,14,25I3)
2000   FORMAT (4F10.3)
3000   FORMAT (1H1,99X=FHPAGE 12,20X15)
4000   FORMAT(12H LOCATION 3A6/12H      DATE 3A6/12H      LEG 13/ )
5000   FORMAT (1X)
6000   FORMAT (3(6XA4,F7.3,4XF6.3,4X12,4XA3))
      IF ILF=1
      GO TO 20
10     PAUSE 77777
20     READ INPUT TAPE 5,1000,(IBUFR(I),I=1,27)
      ITRA=IBUFR(1)
      GO TO (30,40,50,10),ITRA
30     READ INPUT TAPE 5,2000,(XG,YG,DELTX,DELTY)
      GO TO 20
40     NFILE=IBUFR(2)
      GO TO 20
50     NLEGS=IBUFR(2)
      IF(NFILE-IFILE) 60,80,70
60     CALL FILE (NFILE,IFILE)
      GO TO 80
70     REWIND 4
      IFILE=1
      GO TO 60
80     DO 240 J=1,NLEGS
      LEG=IBUFR(J+2)
      ISEG(1) = LEG
90     I=1
100    READ INPUT TAPE 4,3000,(N,JCNT)
      READ INPUT TAPE 4,4000,((ALP(K),K=1,6),ISEGT)
      READ INPUT TAPE 4,5000
110    L=1
120    IF (L-44) 140,140,130
130    I=I+88
      IF (I-JCNT) 100,100,190
140    IF (I-JCNT) 150,150,190
150    IPLUS=I
      IF (IPLUS-JCNT+44) 160,160,180
160    IPLUS=IPLUS+44
      IF (IPLUS-JCNT+44) 170,170,180
170    IPLUS=IPLUS+44
180    READ INPUT TAPE 4,6000,(IRL(M),XT(M),AT(M),IRCH(M),
1 ISENS(M),M=1,IPLUS,44)
      I=I+1
      L=L+1
      GO TO 120
190    IF (ISEGT-LEG) 90,200,90
200    CALL HOLLER(4,24H DP      HI      LO      .IALP)
      DO 230 I=1,JCNT
      IF (ISENS(I)-IALP(4)) 210,220,210
210    ISFNS(I)=6
      GO TO 230
220    ISFNS(I)=5
230    CONTINUE
      CALL POINTS (JCNT)

```

240 CONTINUE
GO TO 20
END(1,1,0,0,0)

```
* ID      X1572616      JAS FA      J. SWANSON. EGG.      FILE SEARCH
*
          FAP
          ENTRY      FILE
FILE      CLA      1,4
          STA      STA1
          CLA      2,4
          STA      STA2
          STA      STA3
STAR T    RTD      4
          CPY      PASS
          TRA      *-1
          TRA      *-3
          IOD
          CLA      IFILE
          ADD      ONE
STAR3     STO      IFILE
          STA1     SUR      NFILE
          TZE      3,4
          TRA      START
          PASS     PZE      0,0,0
          IFIL E   PZE      0,0,0
          NFIL E   PZE      0,0,0
          ONE      PZE      0,0,1
          END
```

CONTINUE READING
END OF RECORD
END OF FILE