

AD \_\_\_\_\_

Award Number: DAMD17-00-1-0208

TITLE: Synthetic Lethality in Breast Cancer Cells: Genes  
Required for Tumor Survival

PRINCIPAL INVESTIGATOR: Gregory J. Hannon, Ph.D.

CONTRACTING ORGANIZATION: Cold Spring Harbor Laboratory  
Cold Spring Harbor, New York 11724

REPORT DATE: July 2003

TYPE OF REPORT: Annual

PREPARED FOR: U.S. Army Medical Research and Materiel Command  
Fort Detrick, Maryland 21702-5012

DISTRIBUTION STATEMENT: Approved for Public Release;  
Distribution Unlimited

The views, opinions and/or findings contained in this report are those of the author(s) and should not be construed as an official Department of the Army position, policy or decision unless so designated by other documentation.

20040524 183

**REPORT DOCUMENTATION PAGE**Form Approved  
OMB No. 074-0188

Public reporting burden for this collection of information is estimated to average 1 hour per response, including the time for reviewing instructions, searching existing data sources, gathering and maintaining the data needed, and completing and reviewing this collection of information. Send comments regarding this burden estimate or any other aspect of this collection of information, including suggestions for reducing this burden to Washington Headquarters Services, Directorate for Information Operations and Reports, 1215 Jefferson Davis Highway, Suite 1204, Arlington, VA 22202-4302, and to the Office of Management and Budget, Paperwork Reduction Project (0704-0188), Washington, DC 20503

<b>1. AGENCY USE ONLY</b> (Leave blank)		<b>2. REPORT DATE</b> July 2003	<b>3. REPORT TYPE AND DATES COVERED</b> Annual (1 Jun 2002 - 1 Jun 2003)	
<b>4. TITLE AND SUBTITLE</b> Synthetic Lethality in Breast Cancer Cells: Genes Required for Tumor Survival			<b>5. FUNDING NUMBERS</b> DAMD17-00-1-0208	
<b>6. AUTHOR(S)</b> Gregory J. Hannon, Ph.D.				
<b>7. PERFORMING ORGANIZATION NAME(S) AND ADDRESS(ES)</b> Cold Spring Harbor Laboratory Cold Spring Harbor, New York 11724  E-Mail: hannon@cshl.org			<b>8. PERFORMING ORGANIZATION REPORT NUMBER</b>	
<b>9. SPONSORING / MONITORING AGENCY NAME(S) AND ADDRESS(ES)</b> U.S. Army Medical Research and Materiel Command Fort Detrick, Maryland 21702-5012			<b>10. SPONSORING / MONITORING AGENCY REPORT NUMBER</b>	
<b>11. SUPPLEMENTARY NOTES</b>				
<b>12a. DISTRIBUTION / AVAILABILITY STATEMENT</b> Approved for Public Release; Distribution Unlimited				<b>12b. DISTRIBUTION CODE</b>
<b>13. ABSTRACT (Maximum 200 Words)</b> The conversion of a normal cell into a cancer cell proceeds through a series of genetic and epigenetic alterations. We have proposed to use well-established genetic methodologies to identify novel anti-cancer targets via their specific, genetic interactions with common cancer mutations. In short, we will identify genetic alterations that are neutral in normal cells, but that are lethal when combined with cancer mutations. This "synthetic lethality" approach may identify potential therapeutic targets that are highly specific to the cancer cell. In the past year, we have created tools that will permit such screens to be undertaken for the first time in mammalian cells and have validated those tools in a model genetic screen.				
<b>14. SUBJECT TERMS</b> Cancer biology, genetics, synthetic lethality, apoptosis				<b>15. NUMBER OF PAGES</b> 12
				<b>16. PRICE CODE</b>
<b>17. SECURITY CLASSIFICATION OF REPORT</b> Unclassified	<b>18. SECURITY CLASSIFICATION OF THIS PAGE</b> Unclassified	<b>19. SECURITY CLASSIFICATION OF ABSTRACT</b> Unclassified	<b>20. LIMITATION OF ABSTRACT</b> Unlimited	

## Table of Contents

Front Cover.....	1
SF 298.....	2
Table of Contents.....	3
Introduction.....	4
Body.....	4
Key Research Accomplishments.....	11
Reportable Outcomes.....	11
Conclusions.....	12

## Introduction

My laboratory has long been dedicated to the application of genetic principles to both the understanding of cancer biology and the search for novel anticancer targets. Since the 1970s, the war on cancer has been based on the notion that studying the disease will lead to the discovery of vulnerabilities, which can be exploited in the clinic. While many underlying genetic determinants of cancer have been identified, this knowledge has failed to translate into new therapeutic strategies, with only a handful of exceptions. One hypothesis is that this failure has largely been due to the genetically intractable nature of cultured mammalian cells. In part due to work from my laboratory, dsRNA-induced gene silencing, or RNA interference (RNAi), in mammalian systems has emerged as a tool that is likely to re-invigorate the field of somatic cell genetics and in the process revolutionize the study of human disease. During the past year, we have reached a point at which any gene in the human genome can conceivably be targeted using small dsRNA gene silencing triggers – *small interfering RNAs (siRNAs)* or *expressed short hairpin RNAs (shRNAs)*. I have recently received an Innovator award from this same program that will fund the construction of shRNA-expression cassettes on a large, and possibly whole-genome scale. We will be able to use these tools within the present programs to test the notion that synthetic lethality is a plausible approach to the discovery of novel anticancer targets. I note that the goals of this grant and that of the Innovator award are distinct. The innovator award is to develop high-throughput procedures to create a resource for the entire cancer community. This program will apply that resource to a very specific problem in cancer biology.

## Body

### *A Genome-wide shRNA library*

Over the past year and with the support of an Innovator award, we have constructed a library of RNAi-inducing constructs that covers ~10,000 cancer relevant genes with from 1 to 6 shRNAs each. This library is the tool that is necessary to move forward with large-scale screens for synthetic lethality in mammalian cells. The library itself is being constructed with support from a number of sources (consider that the overall cost will be ~\$9,000,000). Since it is a key reagent for next year's studies, it is worthwhile to describe the resource here.

The overall goal was to construct a library of RNAi-inducing constructs corresponding to each gene in the human genome. The first phase of the project was to target a number of genes that are relevant to cancer and to make the corresponding constructs available to the research community. Specifically, the National Cancer Institute agreed to support the construction of a total of 9,000 shRNA expression vectors targeted against 3,000 cancer relevant genes.

Additional constructs were and continue to be made with support from the Innovator award and with commercial funding.

#### *Gene selection*

The overall philosophy of which genes to target was discussed extensively with leading investigators in the cancer research community and with the NCI. Categories of genes to be targeted were determined and responsibilities for the construction of gene lists were apportioned. We followed as closely as possible the guidelines for gene choice and built lists of cancer-relevant genes on our own and in consultation with other experts in cancer biology. The list comprised several functionally chosen groups, such as kinases, proteolysis genes, phosphatases, GPCRs and trafficked proteins that are considered accessible to medicinal chemistry. In addition, we prioritized genes based upon cellular processes such as DNA repair, cell-cycle and growth control. Finally, we added lists of genes, which had been deemed relevant to cancer in a number of ways. For example, a group of investigators, including Joan Brugge, Ed Harlow and Josh LeBaer at Harvard have hand-collated 1000 genes which are implicated in breast cancer. We have also included genes based upon collated microarray data on breast and lung cancer. Combining all of these sources of information led to a list of ~9,300 high priority genes. It is our hope that the NCI will find this list satisfactory, but we are certainly willing to add to the list any genes that they feel might contribute to the utility of our overall resource.

#### *shRNA optimization*

We tested carefully a large number of different strategies to achieve an optimal configuration for shRNA expression and structure. This ultimately translated into a 29 nucleotide hairpin with a simple 4 base loop. This is expressed from the U6 snRNA promoter and is preceded by the U6 leader sequence. We continue to update our strategy and have just begun tiling experiments with 2 genes to attempt to derive rules for choosing optimal shRNAs.

#### *Vector construction and validation*

In collaboration with Steve Elledge, we constructed a flexible vector system for harboring the shRNA library (Figure 1). We have demonstrated that this vector can transfer shRNA inserts to a recipient plasmid by bacterial mating with ~100% efficiency. We have also validated transfers in multi-well formats suitable for moving subsets of or even the entire library.

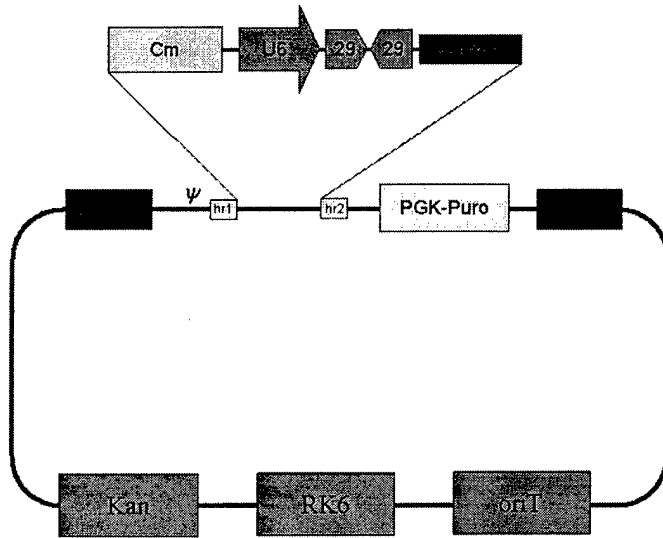

Figure 1. shRNA library vector

#### *shRNA library construction*

We have purchased ~40,000 oligonucleotides corresponding to the ~10,000 targeted genes. Initial purchases were from Illumina. The performance of the first 10,000 oligos was satisfactory but certainly less than optimal. The performance of the second 10,000 oligos was horrendous. Fully 30% of the 96 well plates that were delivered produced complete failures in our cloning procedure. The performance on the remainder was also abysmal. Illumina could provide no quality control data to assure us that the material that they had shipped were even oligonucleotides. This caused a significant delay and waste of resources, from which we are still recovering. Illumina did provide a refund of ~\$100,000, in consideration for this failure. However, this was significantly less than the cost of demonstrating the low quality of their oligos. We have now changed suppliers to Sigma-Genosys and see much better and more consistent performance.

To date, we have sequence verified ~25,000 individual shRNAs. Overall library statistics as of 11/10/03 are shown below. These have been compressed onto ~200 96-well plates, and approximately 10,000 of the clones have been verified for release to the scientific community upon publication of the manuscript (see Figure 2).

### Full Library

Total Number of Accessions designed	9746
Total Number of Accessions ( 3 or more )	7424
Total Number of Accessions ( 2 )	1273
Total Number of Accessions ( 1 )	362
Total Number of Accessions ( 1 or more)	9059
Total Number of Accessions No Data	687
Total Number of Oligos designed	41278
Total Number of verified human shRNAs	28,654
Total Number of mouse designed	15800
Total Number of verified mouse shRNAs	8628

Figure 2. Progress toward library construction

Each of the verified shRNAs is associated with a ~60 nucleotide barcode. Sequence analysis suggests that these are >95% unique. We have not yet decided how to handle the 5% which are associated with more than one shRNA, but given the high probability that the library will be most often used in restricted pools, we don't feel an immediate need to replace those shRNAs with redundant barcodes until the first phase of the project is complete.

Given steady progress, we anticipate finishing this set of genes within the next couple of months.

Working with Rosetta Inpharmatics, we have validated in pilot experiments the use of in situ synthesized oligonucleotides for library construction. Within the next several months, we should move into the final phase of deciding whether this method of library construction is suitable for large scale use. This agreement does not restrict distribution of clones derived from Rosetta oligos in any way.

#### *Library Distribution*

Open Biosystems has agreed to distribute the library and individual clones from the library at a relatively low cost to non-commercial researchers.

### *Loss of function genetics*

The original goal of this grant was to use genetic technologies to enable loss-of-function approaches toward finding new anti-cancer targets in mammalian cells. The discovery that RNAi could be used as such a tool has been a tremendous boon. The availability of a large-scale RNAi-based library now makes our original goals possible.

We are taking two approaches toward identifying synthetic lethal interactions. The first is to use very standard approaches, using either morphological markers of cell death or fluorescent reports of caspase activity in vitro to identify lethal interactions. The second is to use highly-parallel approaches based upon the use of barcode arrays to identify such interactions.

### One-by-one approaches

To validate the use of the library in well-by-well screens, we began by examining the ability of shRNAs within the collection to provoke a well established phenotype. By knowing the answer beforehand, we might get a good appreciation for how well the resource would work in a less characterized context.

We chose to examine 7,800 shRNA constructs for the ability to inhibit proteasome-mediated degradation of a direct proteasome target (ZsGreenProsensin, Clontech). This contains the ODC degenon.

Cells were co-transfected with the construct and individual shRNA expression vectors that had been prepared robotically. For normalization, a dsRED expression vector was also included. Fluorescent signals were read on a Victor II plate reader, and wells were normalized based upon the dsRED transfection marker.

A visual output of the data is shown in Figure 3. We saw a significant enrichment for shRNAs that target the proteasome in this screen. Secondary tests revealed that roughly 22/55 proteasome targeted shRNAs scored positive in our assay, consistent with our expectation that about 1/3 of the shRNAs in the library would be effective.

## Genome wide analysis of the proteasome-mediated proteolysis pathway

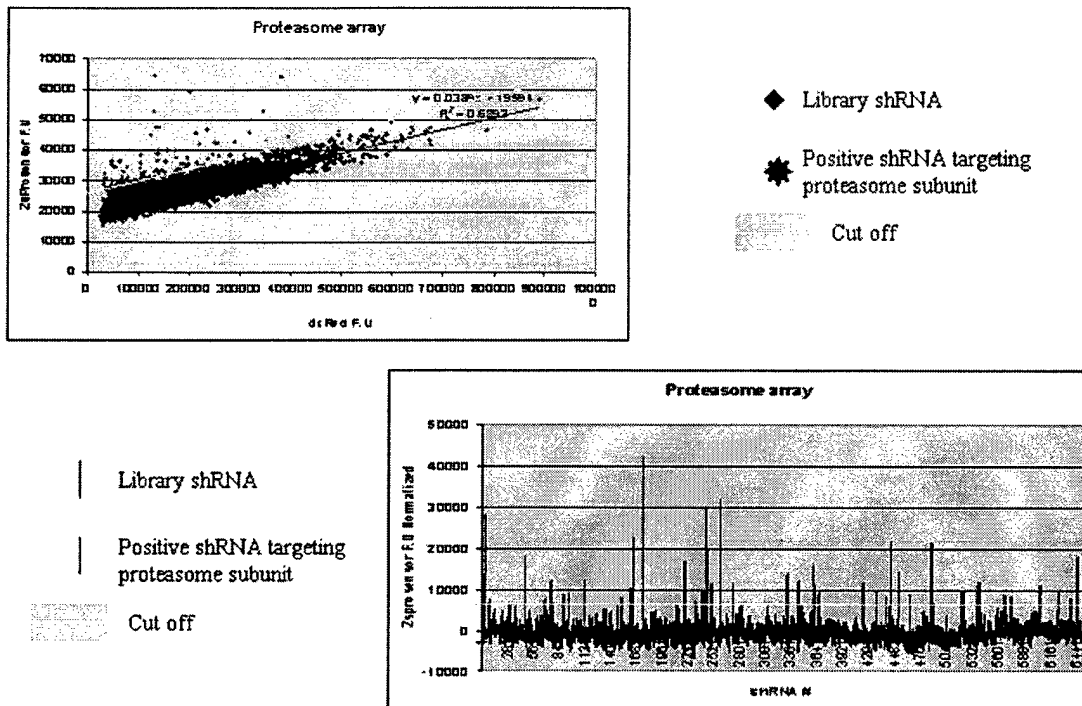

Figure 3. A screen of 7,800 shRNAs for proteasome inhibitors

We are now ready to use these same validated DNA preparations in 96-well plate-based approaches for synthetic lethality screens.

### Highly parallel approaches

Since individual vectors contain unique barcodes that have been associated with each shRNA by sequence analysis, we can use a population-based approach to identify genes that interact with specific pathways. In short, a population of cells is infected with the mixed library under conditions in which each construct is represented by multiple individual infected cells (~1000 cells/construct). This population is subjected to a stress (genetic, environmental or chemical) while a control population remains untreated. The barcodes representing individual vectors are then recovered from the populations by PCR. The frequency change in each clone within the population can then be measured by competitive hybridization of the barcode material to DNA microarrays. For those shRNAs that confer resistance to a treatment, we expect enrichment. Conversely, for those barcodes that sensitize a cell to a particular treatment, we expect a reduction in frequency.

The overall approach is depicted schematically in Figure 4.

## Highly parallel phenotypic screens using RNAi libraries

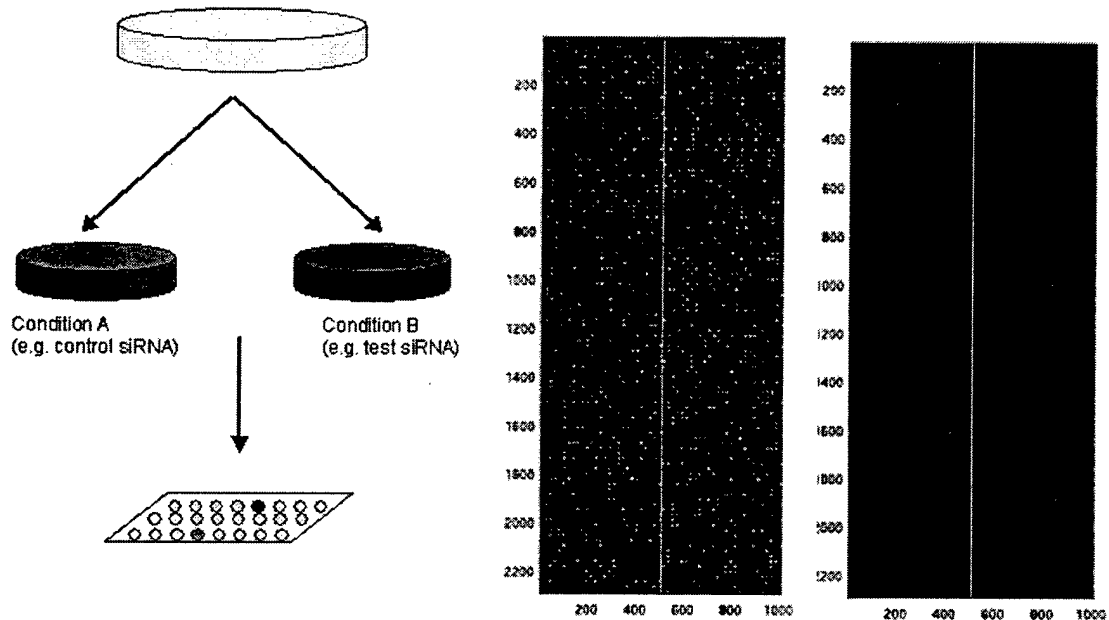

Figure 4 Highly parallel approaches toward synthetic lethal phenotypes.

Thus far, we have examined and validated the underlying technology. As an example, we infected normal human diploid fibroblasts (IMR90) with the library under conditions where the MOI was less than 1/cell. After 48 hours of infection, DNA was harvested and two independent populations were compared by microarray analysis to examine the specificity and reproducibility of the assay. The data is presented as Figure 5.

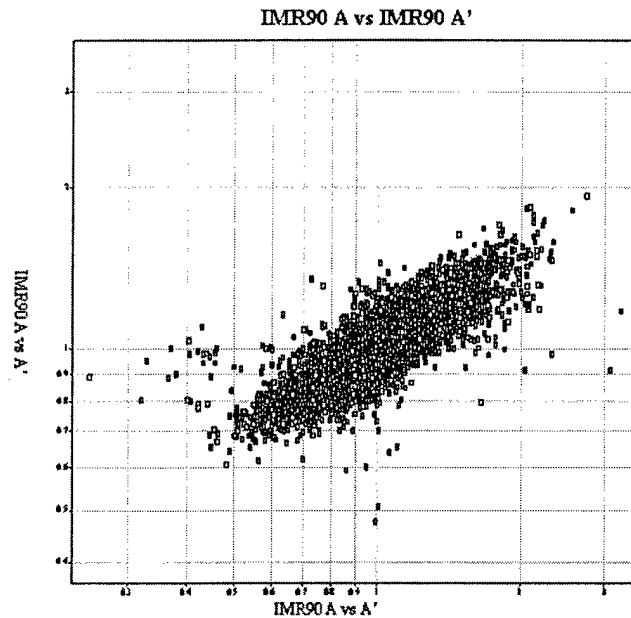

Figure 5 Validation of the barcode strategy

Overall, there is a very high degree of correlation between the two samples. Furthermore, the of the several thousand negative controls on the chip, all but a few show no detectable hybridization. We are now performing time-course experiments to determine the contribution from genetic drift in populations so that we might set appropriate parameters for synthetic lethality screens.

### Key Research Accomplishments

- Preparation of 7,800 DNAs corresponding to shRNA expression vectors from the library
- Validation of the library in pilot genetic screen
- Design of microarrays to monitor shRNA populations
- Validation of the barcoding strategy for genetic screens

### Reportable outcomes

None

## **Conclusions**

We now have in place the tools for large-scale synthetic lethality screens in mammalian cells.