

20040601 138

THE MUSEUM OF
AVIATION —
Preserving Our Heritage

SUMMER
1992

AIR FORCE JOURNAL *of* LOGISTICS

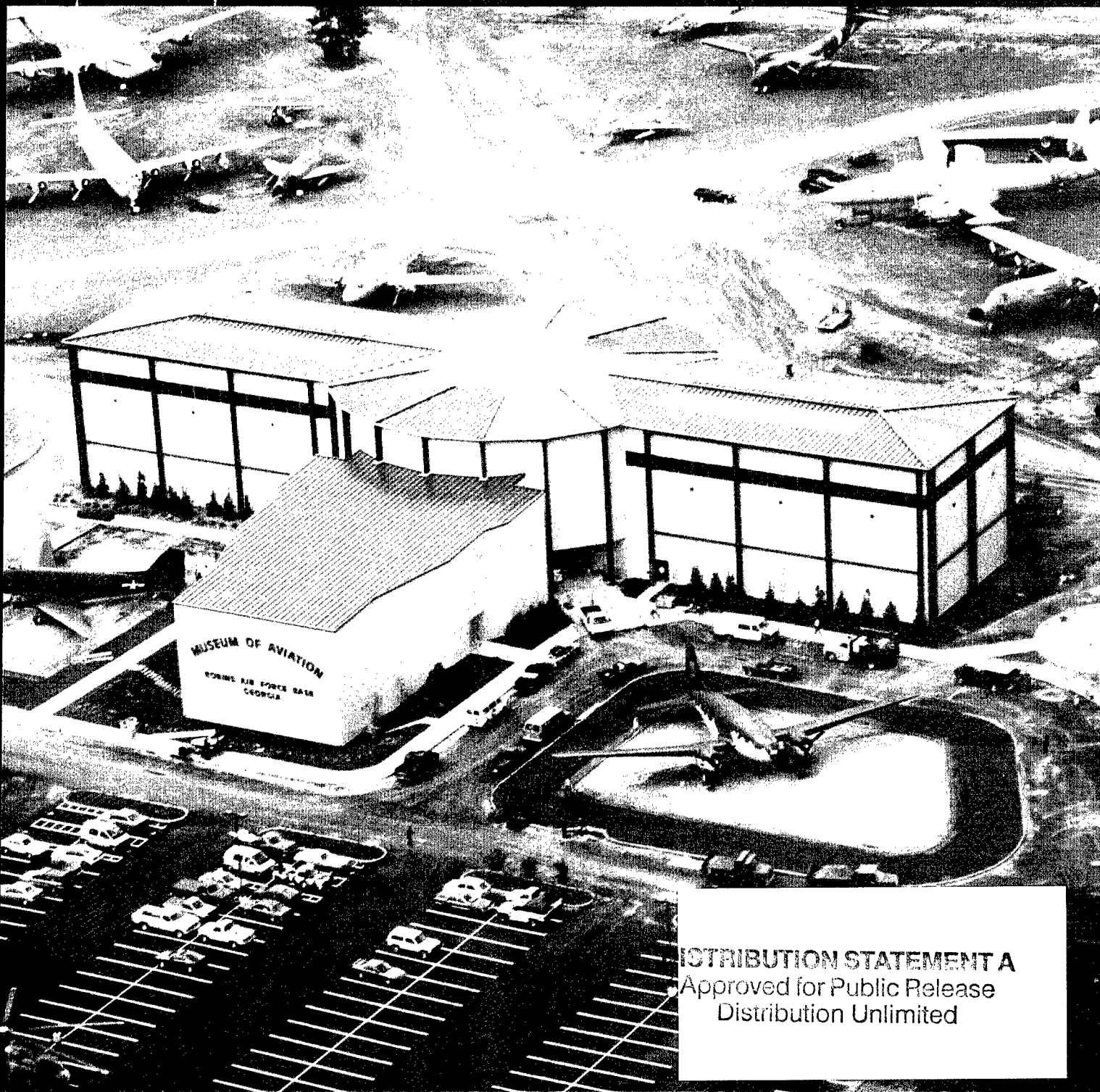

DISTRIBUTION STATEMENT A
Approved for Public Release
Distribution Unlimited

COVER:

An aerial view of the Museum of Aviation at Robins AFB GA. See article on pages 25-29.

AFRP
400-1

VOL XVI
NO 3

AIR FORCE JOURNAL of LOGISTICS

CONTENTS

SUMMER
1992

THEORY OF CONSTRAINTS

- 1 **The Theory of Constraints Approach to Focused Improvement**
Major Jacob V. Simons, Jr., Ph.D., C.P.L., USAF
Lieutenant Colonel Richard I. Moore, Jr., Ph.D., C.P.I.M., USAF
- 6 **The Theory of Constraints: A New Weapon for Depot Maintenance Planning and Control**
Dr W. Steven Demmy
Arthur B. Petrini

DOCTRINE

- 12 **It's Time to Revise Air Force Logistics Doctrine**
Lieutenant Colonel William F. Furr, USAF
- 14 **Combat Support Doctrine: Where We've Been, Where We Are, and Where We Should Be Going**
Lieutenant Colonel Rodney L. Boatright, USAF
- 18 **The Gulf War and Logistics Doctrine**
Wing Commander Gary Waters, RAAF

ARTICLES

- 25 **Preserving the History of Air Power Logistics in the Southeast: The First Decade of the Museum of Aviation at Robins AFB, Georgia**
Dr William Head
Dr Richard W. Iobst
- 30 **System Readiness Analysis for Joint STARS Aircraft**
Richard A. Moynihan
Audrey E. Taub
- 36 **A Simulation Analysis of a Military Entrance Processing Station**
Thomas A. Feo
Gary A. Minadeo
Valentin Novikov
J. Wesley Barnes

DEPARTMENTS

- 23 *Career and Personnel Information*
- 40 *Current Research*
- 41 *USAF Logistics Policy Insight*



Honorable John J. Welch, Jr.
Assistant Secretary of the Air Force
Acquisition

General Ronald W. Yates
Commander
Air Force Materiel Command

Lieutenant General Trevor A. Hammond
Deputy Chief of Staff
Logistics, HQ USAF

Colonel Russell G. Stafford
Commander
Air Force Logistics Management Agency

Editors

Lieutenant Colonel Bruce A. Newell
Jane S. Allen
Air Force Logistics Management Agency

Graphics

Ms Peggy Greenlee

Purpose	The <i>Air Force Journal of Logistics</i> provides an open forum for the presentation of issues, ideas, research, and information of concern to logisticians who plan, acquire, maintain, supply, transport, and provide supporting engineering and services for military aerospace forces. It is a non-directive, quarterly periodical published under AFR 5-7. Views expressed in the articles are those of the author and do not necessarily represent the established policy of the Department of Defense, the Department of the Air Force, the Air Force Logistics Management Agency, or the organization where the author works.
Distribution	Distribution within the Air Force is F. Customers should establish requirements through the PDO system, using AF Form 764, on the basis of 1 copy for every 5 logistics officers, top three NCOs, and professional level civilians assigned. If unable to use the PDO system, contact the editor. <i>AFJL</i> is also for sale by the Superintendent of Documents, U.S. Government Printing Office, Washington, D.C. 20402. Back issues are stocked at AFLMA/JL.
Manuscripts	Manuscripts are welcome from any source desiring to deepen or broaden the knowledge and understanding of Air Force logistics professionals. They should be typed (double-spaced) and be between 1500-3500 words. Figures, graphics, and tables (separate pages) should be numbered consecutively within text. A Z-248 is available if author desires to send a diskette (ASCII file) along with the hard copy of the article (Address: AFLMA/JL, Maxwell AFB, Gunter Annex AL 36114; DSN 596-4087, Commercial (205) 416-4087).
Refereeing	<i>AFJL</i> is a refereed journal. Manuscripts are subject to expert and peer review, internally and externally, to ensure technical competence, correct reflection of stated policy, and proper regard for security.

The Theory of Constraints Approach to Focused Improvement

*Major Jacob V. Simons, Jr., Ph.D., C.P.L., USAF
Lieutenant Colonel Richard I. Moore, Jr., Ph.D., C.P.I.M., USAF*

Introduction

In the Air Force Institute of Technology (AFIT) department of the Fall 1991 issue of the *Air Force Journal of Logistics*, Lieutenant Colonel Richard I. Moore's article, "Constraint Management: The Key to Accelerated Improvement," described a new management approach which is becoming increasingly relevant to Air Force logisticians for at least two reasons. First, the ideas provide a critical link which may be missing in many of the improvement efforts being undertaken throughout the Air Force. Second, the senior leadership of the USAF logistics community has shown a growing interest in the theory and is pursuing a variety of initiatives which will integrate the fundamental concepts into tomorrow's logistics management measurements and methods. (For both these reasons, the theory has become an increasingly prominent aspect of AFIT's graduate program content.) The purpose of this paper is to expand the discussion of the ideas presented in the earlier article and to provide additional insight into their implementation.

Background

Air Force leaders clearly perceive that a "business as usual" approach to our mission in the face of rapidly shrinking financial and personnel resources represents a surefire formula for failure. As a result, internally conceived and generated change is becoming the expectation. Initiative and innovation are finding outlets which critics have traditionally found smothered by stagnant or bureaucratic thinking. Today's watchwords are "continuous improvement." We have repeatedly stated our belief in personnel as our most highly valued resource. Consequently, we believe that improvement will follow from the empowerment of our people to pursue the improvement opportunities they have come to recognize within their own processes.

To facilitate the waterfall of self-improvement efforts we anticipate from within, our leaders have initiated at least two major thrusts. Perhaps the most visible of these are a series of dramatic and comprehensive organizational changes. Far from the commonplace piecemeal shuffling of responsibilities during peacetime, the changes initiated from the Chief of Staff leave few stones unturned. Critics have pointed out that such rapid changes do not permit the time required to effectively or even adequately plan and implement necessary actions. By contrast, proponents suggest that logical reorganization at a macro level without the corresponding specification of detailed micro-level instructions facilitates the opportunity for our talented work force to design the most efficient methods at the operating levels.

While significant reorganization creates the opportunity for change, even the most talented people must be equipped with the tools necessary to take advantage of the resulting opportunities. Therefore, as part of the second major thrust, virtually everyone in the USAF is currently in some stage of training or application of principles of process improvement. The philosophy of Total

Quality Management (TQM), when supported by appropriate tools of implementation, is viewed by many as the vehicle for realizing the needed increases in organizational and individual efficiency and effectiveness. Hardly a person remains who has not received or is scheduled to receive exposure to concepts such as Kaizen, fishbone diagrams, and Process Action Teams.

In summary, the Air Force, facing a mandate for change, has begun to create an environment which will be less resistant to those changes and to arm its members with tools and techniques which facilitate those changes. What is the net result? In some cases, we can see the dramatic, positive changes that we hoped for. Unfortunately, it is not unusual to observe cases where our members have become zealous agents of change, looking for processes to improve. Although they are truly the people most knowledgeable of their processes, their targets of opportunity all too often amount to little more than minor sources of irritation which the organization has long wanted to attack, but has been prevented from doing. In other cases, dollars are sent after pennies in attempts to reduce costs. In the best of these cases, the impact on overall mission effectiveness may be minimal. In the worst cases, the "improvements" are outright suboptimization; i.e., the effectiveness or efficiency of one office is enhanced at the expense of others.

Does this mean TQM is doomed to a slow, disappointing death? While this is certainly a possibility, it is readily apparent that Air Force leaders at all levels believe that TQM represents the best, if not the only, opportunity for the Air Force to succeed. Consequently, it would seem appropriate to seek ideas which will bolster the effectiveness of Air Force TQM efforts.

One significant explanation for disappointments of the sort just described is the lack of a strategy which serves to link the continuous improvement philosophy with the application of TQM tools. One of the TQM tools we teach our people is the concept of Pareto analysis. The idea behind Pareto analysis is simply to prioritize opportunities for improvement in recognition that, simplistically, 20% of the problems (or causes) are typically responsible for 80% of the impact (or symptoms). While helpful *within* a department, this idea is sometimes difficult to apply *across* an organization whose components rely on a variety of diverse measures of interest. The balance of this paper will describe a strategic approach which responds to this need.

The Theory of Constraints

The events affecting today's Air Force are not altogether dissimilar from those which have faced American industry, manufacturing in particular, over the past decade. Increased competition for scarce resources, dramatically changing international relations, and technological revolutions have left those slowest to respond out in the cold. The TQM effort underway in the Air Force has its roots largely in both the methods used by the Japanese to compete successfully with

American industries and in the efforts of those industries to respond.

The Theory of Constraints (TOC) is another concept which is growing in recognition and popularity. Conceived by a dynamic and frequently controversial Israeli physicist, the theory was originally perceived as a competitor with TQM approaches. Now, however, both its proponents and its users describe the theory as a necessary complement to the valuable tools of TQM.

The essence of this complementary relationship may be visualized with the classic analogy of a chain. If an organization's capability is represented by a chain, the most effective organizations are those with the strongest chains. TQM provides a variety of concepts, methods, and tools which can be effectively used to strengthen the links of an organization's chain. However, as we all well know, the strength of a chain is determined by its weakest link. The potential for suboptimization by well-intentioned, but unfocused, improvement efforts may be seen as attempts to strengthen the wrong links of the chain. At best, the weakest link is strengthened. However, in the worst case, the strongest link may be strengthened. The resulting increased weight of the strengthened links may even produce the counterproductive effect of increasing the strain on the weak links.

TOC complements TQM by helping to focus improvement efforts on the weakest links. By perceiving the organization's activities as a single, goal-directed system, TOC can be used to identify where improvements will be helpful and where they will not. In other words, the theory provides a strategy for linking the philosophy of continuous improvement with the tools which can be used to achieve that improvement. The fundamental ideas of the theory are expressed in the following five-step process and are further explained in the remaining sections of this paper:

- (1) Identify the system's constraints.
- (2) Decide how to exploit the system's constraints.
- (3) Subordinate everything else to the above decision.
- (4) Elevate the system's constraints.
- (5) If in the previous steps a constraint has been broken, go back to Step 1, but do not allow inertia to cause a system constraint.

Step 1. Identify the system's constraints.

In terms of the analogy, this first step is where we locate the weakest links. In simplest terms, we are looking for those processes, resources, or procedures which keep the system from achieving its goal with greater success. Note the implicit need for a clearly defined goal. TQM efforts typically do a good job of helping organizations to focus on this starting point. In industry, the goal can usually be reduced to making money, both now and in the future. In today's Air Force, similar financially-oriented objectives may be assuming greater importance than in the past. However, goals can certainly be expressed in other terms more appropriate to the mission of the organization.

It is rare indeed that an organization's members will not believe they know where their system constraints lie. Frequently, they will be right; but just as often they will not. The idea of deciding what limits our success is deceptively simple. Some fundamental ideas are imperative for success at this stage, since failure to correctly identify the system constraint will preclude ultimate success and will alienate those involved in the improvement effort.

First, it is important to recognize that some constraints are within our ability to control while others are not. Note that it may be possible to influence factors outside our organization to some extent. However, the farther afield we look, the more difficult it becomes to achieve the desired changes. Therefore, we should begin by focusing on those factors which fall within our realms of responsibility. When we look within, we frequently find far more opportunity than we first anticipate while bemoaning the vagaries of those above or around us.

Second, a constraint can be, but may not be, physical. It may be financial or it may even be procedural. In fact, those who have successfully applied the theory typically suggest that the majority of constraints are procedural and often self-imposed.

How can we find constraints? There are many ways. Intuition is frequently a helpful starting point, but requires careful validation. Logistics systems typically involve some flow of goods, work, or coordination. Visualizing these flows in terms of production lines can facilitate the process of identifying constraints. If an assembly line contained a constraint, what symptoms would be apparent? For one thing, we might expect to see large backlogs of work waiting in front of the constraint. At the back end of the line, we might expect to find that late jobs can be traced back to our most severely constrained resource. We might also find our constraint to be that portion of our system where expeditors are most likely (based on their experience) to look for problems.

While these heuristics can provide useful starting points, we should still validate the belief that something is a constraint. In terms of resource constraints, this can usually be accomplished by comparing the capacity of the resource with the demand placed on it. If a resource does not have demand for 100% or more of its capacity, it is not a constraint. (However, our management of the resource may be turning it into one. If so, our policies may be the constraint.)

Note that in production environments, the work-in-process buildup is likely to be quite visible. In white-collar environments, it may be less so. (A few inches of paper in an in-basket may represent a significant backlog; e.g., a year's worth of taskings.) Remember that lead-times to accomplish a process or queue times waiting for initiation of the process are also likely indicators.

While it is entirely possible that an organization may have more than one constraint, usually a closer examination of the likely candidates will reveal that many do not. For example, while not every process is completed as quickly as it might be, those which merit focus are the ones which directly limit the achievement of the overall organization's goals. Typical logistics examples include lead-times for purchasing, contracting, distribution, or repair. As a step in the validation of constraints, we might ask, "If this potential constraint did not exist, would the bottom line of the organization improve directly and significantly?" If the answer is yes, we are ready to proceed with the next step.

Step 2. Decide how to exploit the system's constraints.

Once a system constraint has been identified, it seems to be human nature to immediately seek ways to break the constraint. This may represent a behavioral pattern spawned in the age of increasing budgets. However, with large-scale systems, this is typically a frustrating and unproductive effort. The reason something has become a constraint quite simply is that it is probably difficult to overcome. For example, resource constraints such as special-purpose equipment or personnel may involve

substantial capital outlays to overcome. Focusing at the outset on trying to break such constraints leads to the expenditure of large sums of money, disillusionment, or reversion to acceptance of the status quo.

Perhaps the most powerful insight of TOC is its recognition that much can (and should) be done to improve the ability of the system to achieve its goal without having to throw large sums of money or even time at the problem. Steps (2) and (3) of the theory directly facilitate this process.

In Step (2), our awareness of the existence of the constraint enables us to ensure that we are using the constraint as intelligently as possible. Since the constraint, by definition, limits the ability of the entire system to achieve its goal, we begin to recognize that any opportunity lost in the utilization of the constraint reduces the success of the entire system.

This idea leads to improved comprehension of traditional views of productivity. Specifically, we want to exploit our system constraint in two senses. First, we want to ensure that our constraint is fully utilized; i.e., that it constrains us no more than is absolutely necessary. If a physical constraint is only being used productively for 75% of its available time, our system can produce no more than 75% of its potential. Therefore, we recognize that lost time at our constraint represents far more than simply inefficient use of that resource: **it represents a corresponding decrease in the achievement of overall organizational goals.** Consequently, it becomes quite economical to do anything within our power to ensure that the constrained resource's time is used for production. Anything that we can do to remove nonessential activities from the constraint can translate into increased achievement (throughput) for our system. Having work completely prepared in advance for processing by the constraint and off-loading processing that can be done elsewhere are typical examples. (For example, using physician assistants in hospitals is common practice since the time of physicians in such settings is considered to be the greatest limitation of throughput.)

Second, just because we keep a constrained resource busy does not necessarily mean we are getting the most from it. If the demand for the resource exceeds capacity, then some things are not getting done. Are those things the ones we can most afford to lose? In other words, are we using the constraint to work the most important things for which it can be used?

Consider now the case where our constraint has been shown to be a policy. This policy may have been either internally or externally generated. If the policy is an internal one, we may simply be able to revise the policy (essentially skipping to Step (4) and then returning to Step (1) to find out where our next constraint lies).

However, externally imposed policy constraints may be perceived as being even more difficult to overcome than physical resource constraints. Therefore, we would seek ways to exploit the constraint. At first blush, this idea may seem elusive. However, the same logic applies as with a physical constraint. Essentially, we are seeking ways to minimize the extent to which the policy constrains us. A first step in this process is to fully comprehend both the letter and the intent of the constraint. Frequently, the *perceptions* of policy go beyond the constraints the policy *actually* imposed or *intended* to impose. Close reexamination of the policy may reveal that some desired actions which have been broadly perceived as being in conflict with the policy are, in fact, not in conflict. Therefore, we may be able to apply the policy more judiciously or correctly to the benefit of our mission.

Once the actual limitations of an externally imposed constraint are fully recognized, we return to the question of how we can minimize the impact of this constraint on our operations, short of being able to change the policy. Possible responses to this question frequently parallel the types of answers which are relevant when dealing with physical constraints, since both typically concern the allocation of scarce resources. Policy constraints effectively take resources which would not otherwise be constraints and turn them into constraints. Therefore, those pseudo-constrained resources may benefit from the same types of solutions as physically constrained resources. For example, are we using the policy-constrained resources as fully as possible? If, for example, the policy calls for a seemingly excessive series of office coordination steps, have we done everything we can to minimize the impact of that process? Can steps currently done in series be done in parallel? Have we taken action to ensure that offices are prepared in advance to perform their unique, necessary contribution as soon as the document or project reaches them for coordination? (For example, perhaps we can provide advance information which will enable each coordinator to begin preparation earlier.) Have we ensured that only the truly required actions are being accomplished so that time is not lost doing nonessential actions?

In general then, we will likely find we can increase the achievement of system goals by focusing our management attention on keeping the constraint fully used or exploited on those activities which provide the greatest payoff. Note that a variety of TQM tools can be quite useful in accomplishing this step. For example, it makes sense to focus quality inspection/verification efforts immediately prior to the constraint in our workflow to ensure that we do not waste constraint time working on products which will ultimately be scrapped. But what about the utilization of the rest of the organization's resources?

Step 3. Subordinate everything else to the decision in Step 2.

This step, while following logically from the previous one, seems to fly in the face of traditional TQM and productivity notions. In essence, we acknowledge the importance of the constraint by trying to use everything else in the system in a way which supports the effectiveness of the constraint. This includes both active and passive subordination. (Our terms—not those of the theory's authors.)

Active subordination refers to the use of non-constraints in a way which enhances the ability of the constraint to work on what we most need. We alluded to some such actions when we talked about exploiting the constraint. Also, we should accomplish an activity by a resource other than the constraint if possible; e.g., combat troops assisting with low skill tasks at a MASH unit. In addition, the planning of work for non-constrained resources should be done in a way which ensures that the constraint will always have the right work waiting for it. In other words, output of a non-constrained resource which is destined for processing by a constraint should always be accomplished with sufficient lead-time to ensure that the constraint will not have to wait.

Passive subordination refers to *not* doing things which do not directly contribute to achievement of the organization's goals. If, for example, all of the output from a non-constraint must subsequently be processed by the constraint, it makes no sense to output more than the constraint can handle. In fact, to process at a higher rate of output can have serious detrimental consequences. Work-in-process can build up between resources, leading to excessive utilization of raw materials (and investment),

as well as increasing the lead-time required for work to flow through the system.

It is the idea of passive subordination which most directly seems to contradict traditional notions of productivity. In essence, we are saying that 100% utilization of a resource may not be a good thing. If a resource is a constraint, we want maximum utilization (Step 2). But if a resource is not a constraint, we want no higher level of utilization than is necessary to keep our constraints fully utilized. If this represents only 50% utilization, anything greater than 50% does no good and could be harmful.

Similarly, the idea of subordination requires focusing on process improvements. If a particular process is not currently constraining the achievement of our goals, how will improvement of that process help? For example, if we increase the capability of a non-constraint whose output feeds a constraint, we have simply increased the opportunity for idle time or for unwanted buildup of work-in-process. The worst case is that we may even suboptimize by improving a non-constraint at the expense of effective utilization of our constraint. (An exception to these generalizations would exist if we were somehow able to use the additional non-constraint capacity to off-load work from the constraint or to produce system throughput which does not require processing through the constraint.)

When our constraint is an externally imposed policy, we may be guilty of not treating it with the same respect as a physical or internally generated constraint. Perhaps it is easier to simply permit negative impact so we can point our fingers at those responsible for the policy. Sometimes we must attempt to conduct business in the way we deem most appropriate even when that approach does not mesh well with our policy constraint. A prominent example of this occurs when our internal performance measures do not complement (or conflict with) the policy. How often do we find that an organization does not do business the way it says it does? When this is the case, the organization's actions are implicitly saying that the advantages of contradicting policy outweigh the disadvantages. If we search for the source of these perceived advantages, we may find them embedded in personal performance measures which either conflict with or simply do not reinforce exploitation of our policy constraints.

We are sure you share with us the recognition that the symptoms just described frequently represent the efforts of dedicated, concerned individuals to "work around" a potentially detrimental policy: to get the job done in spite of the rules. Certainly, such decisions are judgment calls and merit more discussion than the present article allows. However, we suggest you consider at least two points in this regard. First, organizations which are able to successfully show the adverse impact of what they perceive to be bad policy do so precisely by following the policy (subordinating their own opinions) and letting the chips fall where they may. Second, when organizations successfully work around policy constraints so that the adverse impacts do not occur, what motivation exists for the author of the policy to consider change?

Step 4. Elevate the system's constraints.

The term "elevate" is used here to refer to the idea of lessening the severity of the constraint: to elevate its capabilities. Only after we have fully exploited our constraint and subordinated the rest of our system does it make sense to attempt to increase the capacity of the constraint. Throwing money at the constraint prior

to this point in the process would be an expensive exercise and would offer no assurances that we would fully realize the potential benefits of the improvement. After Steps (2) and (3), however, we can have confidence that improving the capability of our constraint will translate into better achievement of our goals.

Since most of our traditional thinking is focused on how to "break" constraints, it is probably not necessary to talk extensively about how best to do this. This is the step where we buy more machines, hire more people, etc. It is interesting to note, however, that many organizations which have applied TOC never find it necessary to pursue this step. The reason is quite simply that they find the "biggest bang for the buck" has already occurred in the exploitation and subordination steps. Ford Electronic Division, for example, found that their application of TOC enabled them to *reduce* their floorspace requirements to a point where two additional plants would not be required.

Our systems will always have constraints of some sort. In many cases, organizations recognize it is easier or advantageous to leave their constraints where they are. To a large extent, the location of a system's constraint can and perhaps should be considered a strategic decision.

When dealing with policy constraints, this step refers to revising or eliminating the policy. Certainly politics, personalities, and agendas make the art of persuasion paramount in this endeavor. However, substantial support exists for this step accruing from the results of the previous steps. Diligent efforts to exploit a verifiable constraint (Step 2) support contentions that the policy has been fairly, thoroughly, and judiciously applied; i.e., it has been given a fair shake. Furthermore, subordination of other decisions and activities to the policy (Step 3) not only supports the contention that the policy has been fairly tried but also provides evidence of impact. In other words, the actions we have taken in the subordination step should clearly show what has suffered or been sacrificed as a result of the policy. If management chooses, in light of this evidence, not to remove the constraint, they are indicating their acceptance of the tradeoff.

Step 5. If in the previous steps a constraint has been broken, go back to Step 1, but do not allow inertia to cause a system constraint.

As a result of the actions taken so far, it is possible (if not probable) that we have caused our constraint to become a non-constraint. Does that mean we no longer have a constraint? Clearly not. If we wish to continue to improve, something will still be limiting our ability to do so: we may have caused a previous non-constraint to become a constraint. Therefore, it becomes necessary to recycle through the first four steps. This process of recycling is what determines whether the improvement will be continuous or simply a flash in the pan.

What if we have decided we have the constraint where we want it? It is still imperative that we continue to evaluate our system for the simple reason that the environment in which we operate, indeed the very goal itself, will continue to change. Many of the systems we deplore today were, at one point in time, precisely the solutions which were needed. The inappropriateness of the system now lies in the failure of managers to continue to evaluate the circumstances in which it is being operated. The process of recognizing the need for change calls for active involvement since outdated assumptions may be deeply embedded in computer software logic, operating instructions, and even in unwritten policies. Changing environments will call for constant evolution of our systems.

Related Techniques

The five steps described have been implemented in an approach to managing production operations referred to as Drum-Buffer-Rope (DBR). Essentially, the system constraint is perceived as a drum which beats the pace for the production rate of the entire system. Buffers are used to ensure that the constraint always has what it needs to work on (Step 2) and to ensure that constraint output can be converted into system throughput without delay. In addition, management of the buffers offers a simple way of identifying improvement opportunities elsewhere in the system which, if left alone, could impact the effective utilization of the constraint. The idea of a rope is used to communicate the beating of the drum to the input processes of the organization. This communication link serves to ensure that the system does not induct more work than it is capable of converting to throughput. (This is part of the subordination process in Step 3.) The net effect of a DBR system is to produce the same benefits attributed to Just-in-Time (JIT) systems (shortened lead-times, reduced inventory, higher quality) without the need for micromanagement of less critical processes and even in environments not considered amenable to JIT.

In addition to DBR, TOC advocates espouse the use of the structured thinking techniques which led to the development of the theory itself. The technique called Effect-Cause-Effect is one in which troubling problems (actually symptoms) can be traced to their source (core) causes through an iterative process of postulating causes and seeking validating symptoms. Once core problems have been identified, a technique called Evaporating Clouds may be used to identify the apparent conflict which led to the problem and the assumptions which underlie that conflict. Recognition of those assumptions leads to improved insight for breaking the conflict (evaporating the cloud).

A book by Eliyahu Goldratt and J. Cox, *The Goal - A Process of On-going Improvement*, is an excellent starting point for those interested in reading more about the ideas described. (1) This very easy-reading book interweaves fundamental insights with a riveting description of the trials and tribulations of a hard-pressed manufacturing manager. Additional information is presented in the subsequent series of books by the theory's primary advocate. (2,3,4)

Conclusion

We stated at the outset that the Theory of Constraints has begun to generate substantial interest in the logistics community.

One manufacturing company reduced its work-in-process by 70% and its lead-times by 75%. (5) Another achieved the same reduction in lead-times, shrunk inventories by 50%, and increased on-time deliveries from 60% to 95%. (6) Still another manufacturer increased its inventory turnover ratio by 30% with net profit almost doubling. (7)

Success stories in civilian industry are beginning to be paralleled with successes in Air Force Materiel Command (AFMC) depots. The application of TOC at the Oklahoma City ALC enabled the KC-135 overhaul line to realize substantial savings by moving from a seven-day week to a five-day week with no degradation in customer service. At the Aerospace Guidance and Metrology Center (AGMC), increases in the production rate (by approximately 33%) of Pendulous Integrated Gyroscopic Accelerometers have decreased the average unit cost by almost 50% and reduced the backlog. The Technical Order Distribution System at Warner Robins ALC increased its daily production by around 40%, enabling the system to reduce what had been a growing backlog by approximately 90% in six weeks.

While these achievements are typically related to specific high-value processes in specific organizations, recognition of TOC's potential by the general officer corps is making the theory an increasing influence in decisions about the shape of logistics policy and measurement throughout DOD. Complete description of these initiatives merits a separate full-length discussion.

References

1. Goldratt, Eliyahu M., and Cox, J. *The Goal - A Process of On-going Improvement*. North River Press, Croton-on-Hudson, New York, 1986.
2. Goldratt, and Fox, R. E. *The Race*. North River Press, Croton-on-Hudson, New York, 1986.
3. Goldratt, *Theory of Constraints*. North River Press, Croton-on-Hudson, New York, 1990.
4. Goldratt, *The Haystack Syndrome - Sifting Information Out of the Data Ocean*. North River Press, Croton-on-Hudson, New York, 1990.
5. DeGarme, S. "Management Hero," *Success!* March 1987, p. 4.
6. Mangelsdorf, M. E. "What Chief Executives Read," *Inc.*, September 1990.
7. Severs, Jeff L. "The Disaster™ Scheduling System: A Review and Case Analysis," unpublished MS Thesis, AFIT/GLM/LSM/91S-56, School of Systems and Logistics, Air Force Institute of Technology (AU), Wright-Patterson AFB OH, September 1991.

Major Simons and Lieutenant Colonel Moore are assigned to the Air Force Institute of Technology, Wright-Patterson AFB, Ohio.



CALL FOR PAPERS June 3 - June 4, 1993 WORLD WAR II - A 50 YEAR PERSPECTIVE

Siena College is sponsoring its eighth annual *Multidisciplinary* conference on the 50th anniversary of World War II. The focus for 1993 will be 1943—though papers dealing with broad issues of earlier years will be welcomed. Topics include: Fascism and Naziism; Stalingrad, New Guinea, the Air War, North Africa, Sicily and Italy, the North Atlantic; Literature; Art; Film; Diplomatic; Political and Military History; Popular Culture, Minority Affairs, and Women's and Jewish Studies dealing with the era. Asian, African, Latin American, and Near Eastern topics of relevance are solicited.

Replies and Inquiries to: Professor Thomas O. Kelly II
Department of History
Siena College
515 Loudon Rd.
Loudonville, New York 12211-1462

Deadline for submissions: December 1, 1992

The Theory of Constraints: A New Weapon for Depot Maintenance Planning and Control

Dr W. Steven Demmy
Arthur B. Petrini

Air Force managers have a new weapon for improving logistics operations. This weapon is the Theory of Constraints (TOC). TOC is neither hardware nor software. It is not fancy math. It does not require a computer. And it does not take years to implement. Rather, TOC is a view of the world. It is a way of thinking. Most importantly, it is an approach for systematically achieving continuous improvement.

What is the Theory of Constraints? Primarily, TOC is a philosophy of management and a set of approaches for implementing this philosophy. It is largely the work of one man, Dr Eliyahu M. Goldratt. (8,9,10,11) The TOC philosophy provides a precise focus on the goals of an organization and on the constraints that limit the accomplishment of those goals. It seeks continuing improvement by systematically breaking the constraints.

On the shop floor, TOC principles lead to the implementation of synchronized production. Simply defined, synchronized production is a systematic method of moving material quickly and smoothly through the production resources of the firm in response to market demand. In turn, synchronized production can result in significant improvements in productivity, quality, and flexibility to meet changing customer needs. Thus, TOC provides a mechanism to obtain many of the benefits of Just-in-Time (JIT) production within the low-volume environment of depot maintenance.

In this paper, we show how TOC may be used to improve the planning and control of depot maintenance operations. We begin with a review of major TOC concepts and of Drum-Buffer-Rope (DBR) scheduling techniques. Finally, we discuss how DBR scheduling may be adapted to the overhaul and repair environment.

Why Bother?

Why should you learn about the Theory of Constraints? Because the potential payoffs are great. TOC concepts provide important insights into the complex web of processes in modern organizations. This vision usually identifies the need to change policies for scheduling, training, work assignments, performance measurement, or other areas. And unlike other approaches, it identifies those changes that will provide immediate improvements in performance. Often, the needed changes produce major improvements for very little cost. For example, the Process Action Team at Ogden Air Logistics Center (ALC) used TOC concepts to develop new methods for managing aircraft wheel repair. The results? Flow days decreased 75%, while throughput increased by 38%. This was done with no increase in staff or in overtime. The only real costs involved movement of several machines to form work cells.

The Ogden experience is not unique. Table 1 shows a sample of results from other TOC applications within the Air Force Materiel Command. (12) In general, each of these applications

involved a process improvement team which used TOC concepts to identify the primary constraint on system performance. The team then developed methods to break the constraint. Similar results have been reported by divisions of General Motors (1), AT&T (2), DuPont (4), and others (13,15).

Organization	Result
Aerospace Guidance and Metrology Center (AGMC) Accelerometer Repair	Production of the Pendulous Integrated Gyroscopic Accelerometer increased from 35 per month to 47 per month. Overtime decreased, quality improved, and unit repair cost was reduced from about \$1950 per unit to about \$1100 per unit.
Oklahoma City ALC KC-135 Overhaul	Reduced work on KC-135 from a 7-day week to a 5-day week. This resulted in considerable savings to the Center with no reduction of service to the customer.
Ogden ALC Wheel Repair	Reduced flow days 75% while increasing throughput 38%. This was done with no increase in staff or overtime.
San Antonio ALC Engineering Assistance	Flow days for processing Engineering Assistance Requests decreased from 55 days to 15 days. Currently proposed changes should further reduce the flow time to an estimated 5 days.
Sacramento ALC Manufacturing Services	Reduced flow times in the Manufacturing Services Division.
Warner Robins ALC Technical Order Distribution	The average daily production of Technical Orders was increased to 1004, compared to an average of 636 per day for the preceding 5 months.

Table 1.

The Hockey-Stick Phenomenon

Just about everyone has experienced the stress of the end-of-the-period rush, the intense pressure to meet quotas at the end of the period. If the period is a month, this is an end-of-the-month push; if the quota period is a quarter, it is an end-of-the-quarter push. Goldratt observes that the cause of this

problem is the use of two opposing sets of measurements. At the beginning of the period, shop managers are rewarded or punished based on local measurements of efficiency or labor utilization. These measurements encourage minimum setups and large batch sizes. Toward the end of the period, however, there is intense pressure to accomplish the production quota. Managers then use expediting, overtime, and frequent setups to achieve this global objective. As a result, output increases at the end of the period, but at a significant cost. When the period is over, the pressure to meet the quota decreases and myopic measurements of efficiency and labor utilization become the dominant driving force. And thus the cycle continues. (3)

This behavior is called the "hockey-stick" phenomenon because the plot of output over time looks like a row of hockey sticks, down at the beginning of a cycle, and rising sharply at the end. To eliminate this phenomenon, management actions must be guided by a single, consistent set of goals and by measurements that reflect progress toward those goals.

The simultaneous use of traditional cost-accounting measures and period quotas does not meet this need. In fact, Goldratt notes that actions which seek to maximize traditional measures of productivity often have the opposite result. For example, large lot sizes and inflexible schedules will maximize efficiency and direct labor utilization. But large lots produce large work-in-process inventories and waves of material that are difficult to schedule and coordinate. Additional inventory and indirect labor are required to solve these scheduling problems. In turn, large inventories make it difficult to identify and solve quality problems and to respond to changing customer needs. Still more inventory and indirect labor are needed to deal with these problems. Thus, actions to optimize the local measurements of efficiency often result in poor performance in the global measurements of quality, customer service, and productivity. To eliminate these problems, Goldratt argues that new measurements are needed.

What Is the Goal?

To apply TOC, the first step is to clearly identify the goals of the organization and to develop global measurements of progress toward these goals. Local measurements such as labor utilization are replaced by these global measurements. But what is the goal? And what measurements are needed?

Goldratt argues that for many firms, the primary goal is to make money—now and in the future. Yes, there are other objectives—to increase market share, to be a good corporate citizen, to provide jobs—but these do not guarantee the long-term survival of the firm. They are a means to achieve the goal, not the goal itself. But if the firm makes money, any one of these other objectives is possible.

Goldratt argues that there are three primary measures of a firm's ability to make money:

(1) *Throughput* (T) - The rate the firm generates money through sales.

(2) *Inventory* (I) - The money the firm has invested in things it intends to sell.

(3) *Operating Expense* (OE) - The money the firm spends to turn inventory into throughput. (8)

If throughput increases without increasing inventory or operating expense, the firm will make more money. If inventory or operating expense decreases while throughput remains constant, the firm will make more money. The important point is that these three measures should be examined simultaneously. And together, they provide effective operational measures to guide local decisions.

Goldratt asserts that many firms have erroneously focused almost exclusively on reducing operating expense. He refers to this focus as "cost-world" thinking. He argues that more progress toward the goal of making more money, now and in the future, may be achieved by increasing throughput. Thus, TOC advocates a shift from "cost-world" thinking to "throughput-world" thinking, a world in which decisions are based on their impact on T, I, and OE, with particular attention to throughput.

What Is the Goal in Depot Maintenance?

In the Department of Defense, depot maintenance activities operate on a fee-for-services basis. They are financially accountable for their operations and must provide their customers quality products, in a timely fashion, at the lowest possible cost. In this sense, depot maintenance operates much like a business in the private sector.

The defense budget is shrinking. Today, it is even more important for depot maintenance activities to focus on throughput. This focus will enable them to produce more output with available resources and subsequently reduce prices and become more competitive. Competition is the name of the game in the 1990s. For many organizations, survival is at stake.

In the long run, we need measures that directly link depot maintenance decisions to the sustainability and readiness of military forces. Until then, we feel that T, I, and OE are critical, useful global measures for guiding depot maintenance decisions. They recognize the new realities of the 1990s.

The Five Focusing Steps

In TOC, the first task is to clearly identify the goals of the organization and to develop operational measures of progress. The next task is to identify the primary constraints to achieving those goals and to begin a process of continuing improvement that focuses on the constraints. Goldratt advocates a five-step approach to continuous improvement:

(1) *Identify* the system's constraints.

(2) *Decide* how to *exploit* the system's constraints.

(3) *Subordinate* everything else to the above decision.

(4) *Elevate* the system's constraints.

(5) If in the previous steps a constraint has been broken, go back to step (1), but do not allow inertia to cause a system constraint. (10)

The exploitation step means that immediate actions are taken to ensure the system constraint reaches and maintains its maximum rate of output. This usually requires detailed scheduling of the constraint and continuous monitoring of this schedule. When necessary, expediting is done to ensure that the constraint is never idle due to lack of material or operators. In the subordination step, all supporting activities are managed to support the production schedule for the constraint. The elevation step provides for increased levels of constraint capacity. This step often requires new equipment, new procedures, new designs, or new policies from distant bureaucracies; and long lead-times may be involved. In the meantime, exploitation and subordination sustain the highest obtainable level of throughput.

What Are the Constraints?

By definition, a system constraint is anything that restricts an organization from obtaining continuously higher levels of performance relative to the goal. Constraints may be internal or external. External constraints are governed by outside forces, and these forces are usually beyond the control of management. Laws of nature, government regulations, and the characteristics

of the market are examples. Internal constraints refer to policies or resources within the firm. These also come in many forms. Examples of internal constraints are limited physical capacity at workstations, inefficient plant layouts, rigid work rules, limited worker skills, inflexible management policies, worker preferences, and slow or hard-to-change computer systems.

Internal constraints may be classed into two broad categories: resource constraints and policy constraints. *Policy constraints* are the result of organizational rules or preferences. On the other hand, *resource constraints* are physical limitations. A resource constraint exists when demand for a resource exceeds its physical capacity. If market demand exceeds the resource capacity, a true bottleneck exists. Here, management should explore production mix alternatives to assure the most profitable use of limited resources. A second type of resource constraint also exists. In this case, the constraining resource may have sufficient capacity in the long term; but it must be managed and scheduled carefully to avoid "floating bottlenecks."

Goldratt reports that he has helped hundreds of companies implement TOC concepts. For the vast majority of these firms, policy constraints were the primary limit to achieving the firm's goals. Often, these policy constraints are rules to solve problems that no longer exist, or rules designed to optimize local performance measures, rather than global objectives. Once identified, these constraints are often very easy to break. Thus, implementation of TOC ideas may result in immediate, dramatic improvements in throughput.

For example, DuPont reports that a TOC implementation team noticed that the operator of a constraint resource was manually counting parts, delaying the machine. (4) The team moved a counter from an unused machine, saving one hour per eight-hour shift. Next, the team noted that the constraint machine was performing rework for a non-constraint machine. Though this activity made sense using the traditional cost-accounting calculation of unit cost, it made no sense from a global perspective. Finally, the team observed that the three different operators of the constraint resource used different work methods. As a result, a standard method was developed and implemented. Within five weeks, constraint production increased from an erratic output that averaged 3,000 units per shift to a steady output of 8,000 units per shift. After backlogs were filled, production was set at 5,000 units per shift to match market demands. Note that the constraint was broken by changing work rules and methods. Very little investment was involved, and the improvement was quick and dramatic.

We believe that depot maintenance organizations will discover many situations similar to the DuPont experience. Current policies and work rules may be reasonable using the myopic view of traditional cost accounting. But if a resource is a constraint, the rules of the game should change. Lost production at a constraint limits the output of the entire organization. Similarly, full utilization of non-constraints does no good; it only builds work-in-process inventory, not output, since the output rate is controlled by the system constraint. Using the same policies for both types of resources is clearly wrong. But in today's world, most organizations use the same rules to manage all types of resources.

This is but one example of the need for significant policy changes in depot maintenance. There are many others. The good news is that finding what needs to be changed is often easy. When policies are evaluated from a global perspective, by looking at the impact of a policy upon the goals of the firm, the need for change is often obvious. The bad news is that neither management nor workers like change. And thus the major

challenge of TOC is the major challenge of managers everywhere: how to implement change.

Drum-Buffer-Rope Scheduling

After initial policy changes are made, one of two conditions will result:

(1) There is adequate capacity to satisfy all requirements. Here, customer demand ("the market") becomes the system constraint.

(2) A physical resource becomes the system constraint. The constraint might be on the shop floor, in order entry, in shipping, or in engineering. It might be anywhere in the complex network of activities that convert labor, materials, and information into completed customer orders. The constraint might be caused by policy constraints that are not yet broken. In either case, the next step is to synchronize shop operations.

In TOC, production is synchronized using DBR scheduling. (7:661) In TOC terminology, the drum is the system constraint; it sets the beat or production schedule for the rest of the shop. The ropes are schedules that tie gateway operations, assembly, and shipping activities to the work schedule for the constraint. The buffers are extra material strategically placed to protect the throughput of the system.

In DBR scheduling, *time buffers* are used to release material before the absolute minimum lead-time needed to complete production operations. Thus, a time buffer does not contain a specific number or type of parts. Rather, it provides extra time to resolve disruptions in flow that might adversely affect throughput. (6:52)

In the Theory of Constraints, most, but not all, inventory is removed from the shop floor. The inventory is viewed as a strategic weapon and is used to protect the system from the statistical fluctuations that occur in any network of dependent activities. (15) The only way to avoid these fluctuations is to eliminate variability in all elements of the manufacturing system. When this is done, all inventory may be eliminated. But as long as variability exists, buffer stock is used to absorb variations that could disrupt throughput.

DBR scheduling uses three types of buffers. The *constraint buffer* protects the throughput of the constraint. It assures the constraint is never idle due to upstream disruptions. The *shipping buffer* protects the integrity of promised due dates. It provides protection from possible disruptions at the constraint or operations that follow the constraint. Finally, the *assembly buffer* stages non-constraint parts at assembly points downstream from the constraint. It provides assurance that parts produced on the constraint are never delayed due to shortages of non-constraint parts.

Scheduling the Shop

The five basic steps in DBR scheduling are:

- (1) Identify the constraint resources.
- (2) Establish buffer requirements.
- (3) Schedule the constraint resource.
- (4) Forward-schedule the downstream work centers to establish promise dates for shipments.
- (5) Using the constraint and shipping schedules, backward-schedule to set the release dates for materials at gateway operations. (6)

Figure 1 illustrates the relationships among the three types of TOC buffers. In the figure, the polish process is the system constraint. The schedule for the polish operation is based on the available polish capacity, market demand, and the time required to process the order from the constraint resource through the last

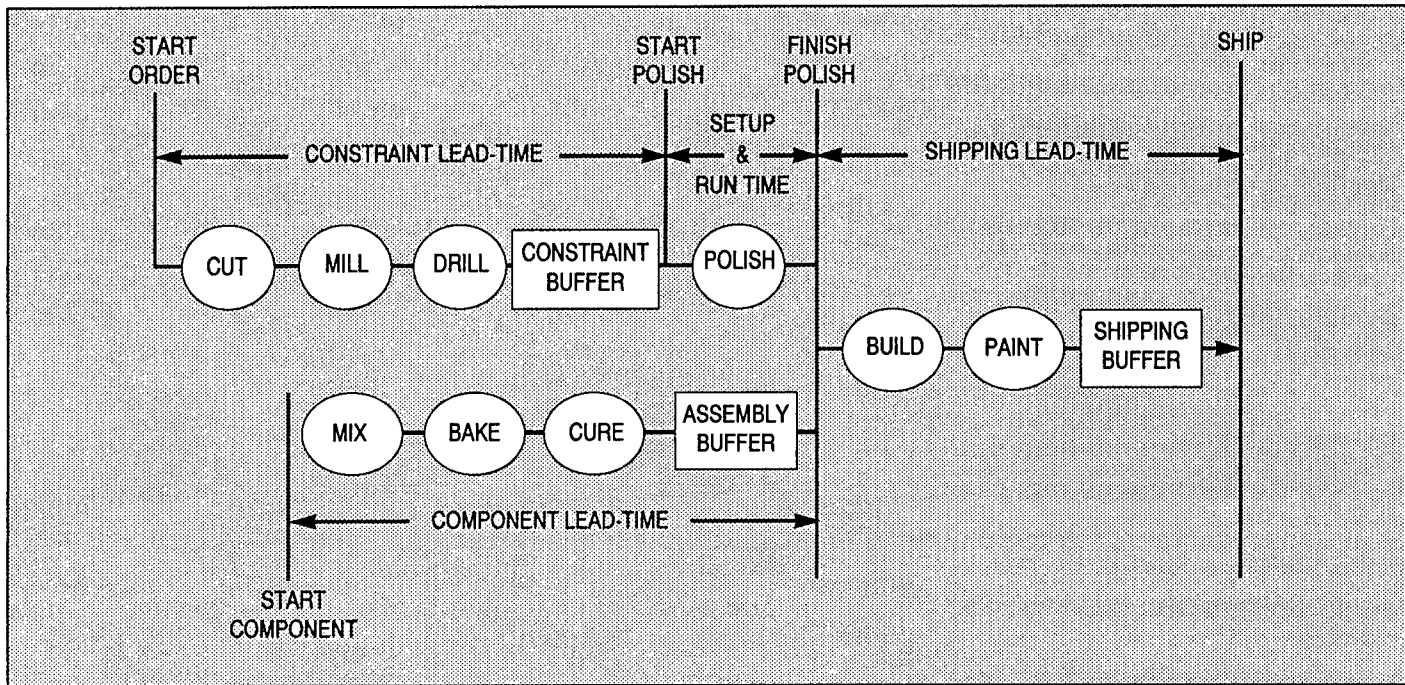

Figure 1. Drum-Buffer-Rope Relationships.

operation. After the polish process is scheduled, achievable promise dates and shipping schedules may be determined by adding the shipping lead-time to the planned completion time for the polishing step. Finally, scheduled start times for the gateway (first) operations, cut and mix, may be found by backward scheduling from the constraint and shipping schedules. If more material is needed to support these operations, the time for placing replenishment orders may also be computed.

In many job shop installations, dispatch lists are used to sequence jobs at each work center in the plant. Under TOC, less paperwork is needed. The material release schedule lists the dates and times to start work at gateway operations. The constraint schedule lists the sequence of jobs to run on the drum, while the shipping schedule lists orders in promise date sequence. Finally, an assembly schedule is needed for each operation that produces common parts. The assembly schedule lists the quantity and sequence of units to be assembled. It is needed to ensure that parts which are planned for the use in one product, say X, are not used to produce some other product Y. If orders are not assembled according to the material plan, parts may be consumed out of sequence, and the synchronization of material flows will be lost.

On the Shop Floor

In TOC, shop floor operations differ from traditional practices. In particular, lot splitting is used extensively. (7) In TOC terminology, a "process batch" is the number of units produced after a workstation sets up to make a part, say part A, but before it changes over to make some other part B. On the other hand, a "transfer batch" is the number of units physically moved from one workstation to another. In most job shops, the transfer batch and the process batch are the same; i.e., all the units on a shop order are completed at one workstation before the batch is moved to the next. In these shops, a job that takes one hour at each of four work centers may require four weeks to complete, about one week in queue and one hour in work at each of the four work centers.

Note that the four-week job described could be done in a half day if each work center started the job immediately after it is completed at the previous stage. Even faster flows may be achieved if each piece is carried from one station to the next as soon as the piece is completed; that is, if the transfer batch is one unit. For example, suppose we have an order for 60 units and each unit requires one minute of processing at each of four steps, and three minutes to move from one station to the next. In this case, the last station can complete the last piece just a few minutes after the first station completes the 60th piece, a total time of slightly more than one hour from job start to job finish. Thus, small transfer batches result in very fast flow times and small levels of work-in-process.

TOC assumes that the system constraint is scheduled to maximize throughput. Thus, the process batch size at the system constraint will usually equal the order size. However, the process batch may be even larger if orders may be combined to save setup time—and thus increase throughput—at the constraint. In contrast, Goldratt argues there is no reason to save setup time at non-constraints if the work force is fixed. In the short term, this is almost always true. Thus, in TOC the transfer batch size is kept small. This results in greatly reduced work-in-process investments and much quicker flow times.

One way to implement DBR scheduling is to provide each non-constraint work center with a list of jobs scheduled through that center in the near future. When workers complete a job, they check each of the possible feeding stations for completed work and bring forward any items ready to be transferred. In this case, the transfer batch size is variable—it equals the number of units that are ready when the workers check the stations.

Establishing Buffer Sizes

How large should the buffers be? They should be large enough to ensure that the system constraint is never delayed due to the lack of material and that promised ship dates are protected from downstream disruptions. Schragenheim and Ronen suggest the following computations. (14)

Let:

MinLT = the absolute minimum lead-time between the release of material and the arrival of that material at the buffer area. When a transfer batch size of one is possible, MinLT usually equals the cumulative time for a single unit to be moved and processed through each operation between the release point and the buffered operation.

BT = the chosen buffer size. BT is stated in terms of hours of production at the buffered operation.

Rp = the lead-time associated with the specific buffer. Thus, Rp is the difference between the material release and the scheduled start time for the buffered operation. Rp may be thought of as the length of the rope that ties the material release schedule with the schedule for the buffered operation.

Hence,

$$Rp = \text{MinLT} + \text{BT}$$

which means

$$\text{BT} = Rp - \text{MinLT}$$

In practice, MinLT will often be very small relative to Rp. In this case, the material release lead-time and the buffer size are almost identical.

To avoid disruptions in flow, the material release lead-time Rp must be bigger than AvgLT, the average actual time required for an order to progress from material release to the buffered operation. In mathematical terms, Rp should be two or three standard deviations larger than the average lead-time. Thus, probability calculations or detailed simulation models may be used to set Rp. In practice, however, it is often convenient to simply guess a value for Rp and then use buffer management to adjust this initial value.

Avoiding Floating Bottlenecks

Many firms that have not yet synchronized shop floor operations experience *floating bottlenecks*. These are resources that appear to be overloaded on certain days, but have idle capacity at other times. Unless special precautions are taken, queue times at these resources will be very erratic; and large buffers will be required to protect system throughput. However, large buffers may be avoided by adjusting material release dates to compensate for anticipated temporary overloads. (11:229-252) Briefly, one first develops the schedule for the constraint. Next, the expected day-by-day loads on non-constraint resources are computed. If the load on any given day exceeds the available capacity, the corresponding orders must be started earlier than usual to avoid delays that endanger throughput.

Buffer Management

Buffer sizes are stated in terms of hours of production. For example, suppose the constraint buffer is set at 24 hours of production. If work proceeds according to plan, material is released at the gateway operations on schedule; and the initial units rapidly proceed in small transfer batches toward the constraint. If the transfer batch is one unit and processing and

move times for a unit are small, the initial units could begin arriving at the constraint almost immediately; i.e., about 24 hours prior to the scheduled start on the constraint. Thus, if everything is working smoothly and there is no queue time at non-constraints, the amount of work queued before the constraint should equal the value of the constraint buffer. When there are queuing delays, the amount of material in the buffer will be slightly less.

Of course, eventually something always goes wrong. Breakdowns or other schedule deviations will cause material to be delayed and thus reduce the buffer. Buffer management monitors the amount of material in the buffers and triggers expediting actions when the buffer falls to a critical level. For example, what if the schedule for the polish operation in Figure 1 looks like this:

Day	Part	Quantity	Total Hours
Monday	A	30	5
	B	6	3
Tuesday	B	6	3
	C	5	5
Wednesday	C	2	2
	D	2	6
Thursday	D	1	3
	A	30	5

Suppose the polish operation is scheduled to work eight hours per day. Figure 2 shows the planned load in the constraint buffer on Monday morning. Since the buffer was set to 24 hours of production, it corresponds to 3 days of work at 8 hours per day. In the figure, each letter represents one hour of scheduled work; and a capital letter indicates that the scheduled material has been received at the buffer. Thus, the five As indicate that five hours of polish work for part A are scheduled on Monday, and all of the material is available. After part A, six hours of part B are scheduled. The small "b" in the Tuesday column shows that material needed for one hour of part B work has not yet reached the polish buffer. At the moment, there is only enough part B material to work two of the three hours scheduled for Tuesday. On the other hand, all of the material for part C is at the polish work center.

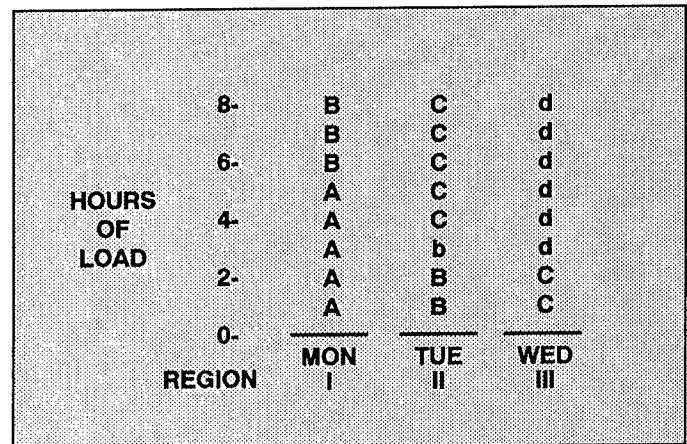

Figure 2. Load Profile Under Buffer Management.

In TOC terminology, missing material that is scheduled to be in a buffer is called a "hole" in the buffer. The presence of holes may trigger expediting actions. Schragenheim and Ronen suggest that the buffer should be divided into three approximately-equal regions. (14) Thus, if the buffer contains 24 hours of material, each region corresponds to about 8 hours of production. If a hole appears in Region III, the right-hand side region, there is little need for concern. There is still a lot of time until these parts are needed by the drum. On the other hand, a hole in Region II, the middle region, calls for locating the missing parts. If a major problem is discovered, expediting may be needed. Finally, Region I is the left-most portion of the buffer. A hole in Region I threatens the output of the entire plant. When a hole appears in this region, immediate expediting is needed. The hole should have been noticed when it was still in Region II. When the hole moves to Region I, it becomes a top priority item.

When expediting is done, the cause of the material delay should be identified and recorded. After a period of time, this list of causes will identify high priority areas for continuous improvement activities. After the causes of delays have been eliminated, the buffer size may be reduced.

Earlier we noted that it is often convenient to guess at the initial buffer size and to use buffer management to adjust this beginning value. If holes appear frequently in Region I, the buffer size should be increased. Conversely, if holes rarely reach Region I, the buffer is too large.

Drum-Buffer-Rope in Depot Maintenance

Depot maintenance involves many types of activities, ranging from the refurbishment and modification of complete aircraft to the repair and calibration of electronic components. DBR scheduling appears best suited for repair operations that involve many job steps and the physical movement of material from work center to work center. Landing gear, wheels, hydraulic cylinders, armaments, ejection seats, and many other commodities appear to be good candidates for DBR scheduling. To use DBR scheduling for depot repair, the standard DBR procedures must be modified to deal with disassembly operations and with the probabilistic nature of repair. Buffers must also reflect the variability of the supply system.

In manufacturing, every component of an end item must be either purchased or built. In depot maintenance, however, many components are obtained by the repair of an unserviceable unit; and component repair cannot start until the end item has been disassembled. Thus the lead-time relationships shown in Figure 1 must be enhanced to calculate the induction schedule for the repairable end item. If each repaired component must be mated with the original end item, the end item disassembly schedule must be consistent with the longest flow time to repair or replace each of the components.

The probabilistic nature of the repair process must also be considered. In manufacturing, it is fairly easy to compute the exact amount of materials, labor, and capacity needed to support a given shipping schedule. In maintenance, however, the exact amount of materials needed for repair is often not known until a unit has been cleaned and inspected. Similarly, the exact set of needed repair operations is not known until the failure mode has been identified. Thus, a DBR implementation in repair must begin the planning process with expected values and refine these estimates as inspection, diagnosis, and repair operations

progress. Higher levels of uncertainty and slow information feedback will require larger buffers.

Finally, the buffer sizes must reflect the realities of the repair environment and the variability of the supply system. The assembly and constraint buffers protect system throughput from disruption due to material delays. These delays may be due to problems with internal operations or due to delays in obtaining material from depot supply. Together, the combination of potential resupply delays and repair variability may require relatively large buffer stocks. Buffer management should then be used to identify the sources and relative magnitude of this variability and to guide the selection of continuous improvement projects.

Summary

The Theory of Constraints is a major management movement. It provides a precise focus on the goals of the organization and on the constraints that limit the accomplishment of those goals. It leads to synchronized production and to a process of continuing improvement that systematically breaks the constraints. There are numerous examples, both military and commercial, of the value of this approach.

TOC concepts have great potential for improving depot maintenance. Only minor modifications are required to implement the standard TOC techniques within the repair environment. Policy changes will be needed. These will be the most difficult problems to solve. But once solved, the payoff is increased productivity and continuing progress toward the goal.

References

1. Callahan, Joseph M. "GM's Plant Saver," *Automotive Industries*, March 1989.
2. Cannon, Joseph J., and Kapusta, Gary. "Just-in-Time at AT&T's Reading Works," *Just-in-Time Seminar Proceedings*, 24-26 July 1989.
3. Chase, R. B., and Aquilano, N. J. *Production and Operations Management: A Life Cycle Approach*, 5th Edition, 1989, pp. 791-832.
4. Davis, N. S., and Fox, G. "JIT Case Study: DuPont Powder Metal," *Just-in-Time Seminar Proceedings*, 24-26 July 1989.
5. Demmy, W. S., and Giambroce, A. J. "MRP II in AFLC Maintenance Planning and Control," *Air Force Journal of Logistics*, Fall 1990, pp. 7-11.
6. Fawcett, S. E., and Pearson, J. N. "Understanding and Applying Constraint Management in Today's Manufacturing Environments," *Production and Inventory Management Journal*, Third Qtr, 1991, pp. 46-55.
7. Fogarty, D. W., Blackstone, J. H., and Hoffmann, T. R. *Production and Inventory Management*, South-Western Publishing Co., 2nd Edition, 1991, pp. 656-676.
8. Goldratt, E. M., and Cox, J. *The Goal*, North River Press, Milford CT, 1986.
9. Goldratt and Fox, Robert E. *The Race*, North River Press, Milford CT, 1986.
10. Goldratt, *The Theory of Constraints*, North River Press, Milford CT, 1990.
11. Goldratt, *The Haystack Syndrome*, North River Press, Milford CT, 1991.
12. Hinneburg, Patricia A. "TOC: The Quiet Revolution," *Proceedings of the 1992 Aerospace and Defense Symposium*, Los Angeles CA, 4-6 May 1992.
13. Reimer, Glenn. "Material Requirements Planning and Theory of Constraints: Can They Co-exist? A Case Study," *Production and Inventory Management Journal*, Fourth Quarter, 1991, pp. 48-52.
14. Schragenheim, E., and Ronen, B. *Buffer Management: A Diagnostic Tool for Production Control*, Working Paper 22/89, Y. Goldratt Institute, New Haven CT, p. 38.
15. Spencer, Michael S. "Using 'The Goal' in an MRP System," *Production and Inventory Management Journal*, Fourth Quarter, 1991, p. 24.

W. Steven Demmy is Associate Professor of Management Science at Wright State University and a Senior Consultant with ENTEK, Inc. Arthur Petrini is Manager of the Dayton Office of ENTEK, Inc.



It's Time to Revise Air Force Logistics Doctrine

Lieutenant Colonel William F. Furr, USAF

Our current Air Force logistics doctrine was first published in December 1985 as AFM 2-15, *Combat Support Doctrine*. It was reissued in April 1987 as AFM 1-10. While not everyone wholeheartedly accepted its approach or contents,¹ this manual was generally welcomed since the previous Air Force logistics doctrine had been published almost 20 years before.²

A lot has happened since this manual was released. Secretary Rice's *Global Reach—Global Power* has given us a new vision of what the Air Force is all about. Operation Desert Storm vividly demonstrated the extent to which airpower can dominate modern warfare. A new AFM 1-1, *Basic Aerospace Doctrine of the United States Air Force*, has refocused our thinking about war and the best uses of aerospace power. The demise of the Military Airlift Command (MAC), Strategic Air Command (SAC), and Tactical Air Command (TAC), and the creation of the Air Combat Command and Air Mobility Command eliminated, at least organizationally, the often inappropriate distinctions between "tactical" and "strategic" aircraft.³ The merging of Air Force Logistics Command (AFLC) and Air Force Systems Command (AFSC) into Air Force Materiel Command created a new (although not in the historical sense) wholesale logistics organizational structure.

These watershed events and other changes, such as composite wings and the Defense Business Operating Fund (unit cost accounting), demand that we reexamine our current logistics doctrine. We must ensure that it accurately and adequately reflects the lessons of the past and is relevant for the future.

The opportunity to reexamine our logistics doctrine first arose when AFR 1-2, *Assignment of Responsibilities for Development of Aerospace Doctrine*, was revised in September 1990. This revision redefined the categories of Air Force doctrine as basic (AFM 1-1), operational (AFM 2-series), and functional (AFM 3-series). Of specific interest to logisticians was functional doctrine which "establishes principles, concepts, and considerations that guide the conduct of combat support operations to sustain, maintain, and assist the conduct of the air war."⁴ Based on an Air Force decision, AFM-1-10 will be retained to provide basic logistics (combat support) doctrine with AFM 3-A, *Logistics Doctrine*, focusing on wing-level guidance (Table 1).

A few tentative efforts have been made to develop a new AFM 1-10 and the new AFM 3-A. In July 1990, HQ USAF/XOX solicited comments "concerning changes that should be made to this manual [the existing AFM 1-10] to fulfill its new role as the lead 3-series publication."⁵ In February 1991, HQ USAF/LE solicited "thoughts on those principles that should be contained in the 3-series manuals." This latter request stated that, in the new AFM 3-A, "emphasis will be placed on fundamental principles of warfighting doctrine, not peacetime organization and processes." It also stated that of particular interest were "principles of supply, maintenance, transportation, and logistics plans."⁶ Although efforts have continued to develop new logistics doctrine, an initial draft has not been circulated for formal coordination.

There have been a number of developments since 1985 that will directly impact any new Air Force logistics doctrine. Perhaps foremost of these is the release of Joint Test Pub 4-0, *Doctrine for Logistic Support of Joint Operations*. This new keystone joint doctrine discusses logistics in terms of six functional areas (supply, maintenance, transportation, general engineering, health services, and other services) and four process elements (acquisition, distribution, sustainment, and disposition). It also discusses seven logistics principles (responsiveness, simplicity, flexibility, economy, attainability, sustainability, and survivability) as well as logistics planning and joint logistics at the operational level of war.⁷ The Joint Chiefs of Staff have also approved for development 11 Joint Pub 4-0 subordinate publications which will provide guidance on a wide range of different topics (Table 2). Since Joint Pub 0-2, *Unified Action Armed Forces (UNAAF)*, requires Service doctrine to be consistent with joint doctrine,⁸ Joint Pub 4-0 must certainly have a significant impact on any rewrite of Air Force logistics doctrine.

Another development is the publication of the new AFM 1-1 which lists logistics and combat support as two different "typical" force support missions. In this manual, logistics is described as those activities that create and sustain aerospace forces. Combat support is described as those activities which provide essential services to aerospace organizations and their personnel in operational conditions. The new AFM 1-1 also

USAF FUNCTIONAL DOCTRINE		
Document	Title/ Document to be Replaced	Primary Review Authority
AFM 3-A	<i>Logistics Doctrine</i>	AF/LEX
AFM 3-B	<i>Air Base Operability</i>	AF/XOX
AFM 3-C	<i>Communications-Computer Systems</i>	AF/SC
AFM 3-D	<i>Tactical Deception</i>	AF/XOO
AFM 3-E	<i>Electronic Combat (EC) Operations</i> (Renumber current AFM 2-8)	AF/XOO
AFM 3-F	<i>Aerospace Environmental Operations</i> (Renumber current AFM 2-31)	MAC
AFM 3-G	<i>Airspace Control in a Combat Zone</i> (Renumber current AFM 2-12)	TAC
AFM 3-H	<i>Psychological Operations</i>	AF/XOX
AFM 3-I	<i>Intelligence</i>	AF/IN
AFM 3-J	<i>Search, Rescue, and Recovery Operations</i> (Renumber current AFM 2-36)	MAC
AFM 3-K	<i>Civil Engineering Combat Support Doctrine</i> (Released in Apr 91 as AFM 3-2)	AF/LEE
AFM 3-L	<i>Training</i>	AF/XOO
AFM 3-M	<i>Combat Camera</i>	AF/SC
AFM 3-N	<i>Army-Air Force Air Base Ground Defense</i>	TAC

Table 1.
(Adapted from AFR 1-2, Attachment 3, 10 September 1990)

JOINT LOGISTICS PUBLICATIONS

Joint Pub Number	Title	Lead Agent
4-0	<i>Logistic Support for Joint Operations</i>	J-4
4-01	<i>Defense Transportation System</i>	J-4
4-01.1	<i>Airlift Support to Joint Operations</i>	USTRANSCOM
4-01.2	<i>Sealift Support to Joint Operations</i>	USN
4-01.3	<i>Joint Movement Control</i>	USA
4-01.5	<i>Water Terminal Operations</i>	USTRANSCOM
4-01.6	<i>Joint Logistics Over the Shore</i>	USN
4-02	<i>Health Service Support in Joint Operations</i>	USA
4-03	<i>Joint Bulk Petroleum Doctrine</i>	J-4
4-04	<i>Joint Doctrine for Engineering Support</i>	J-4
4-05	<i>Mobilization</i>	J-4

Table 2.¹³

discusses base operability and defense as a typical force support mission. The supporting essay for these missions (Essay T) identifies and discusses four factors that govern force employment and sustainment (force composition, support requirements, base operability, and logistical depth).⁹ While Essay T does not provide an in-depth discussion or extensive documentation, it does provide worthy food for thought for the writers of any new Air Force logistics doctrine.

With these events and development in mind, AFM 1-10 should take a radically different approach than did its predecessor.¹⁰ It needs to emphasize a more balanced operations-oriented and less systems-dependent perspective. It should reflect a more fluid and intimate interrelationship between combat operations and logistics/combat support. Abstract processes and systems tend to grossly oversimplify the complex nature of combat. They also tend to encourage the reader to incorrectly view combat operations and logistics/combat support activities as mechanistic and compartmentalized, when in fact they constitute an indivisible combat capability. The new AFM 1-10 must clearly articulate the fact that the form and substance of logistics and combat support are directly affected by operational circumstances such as the degree to which US forces possess the initiative. Such circumstances also include the degree to which initial defensive/offensive air operations succeed in preventing enemy attrition of our combat forces and logistics/combat support assets and the measures taken to make high-value logistics/combat support functions as robust as possible.

The new AFM 1-10 should adopt the Joint Pub 4-0 principles of logistics without change, but it should discuss these principles in terms of support of combat air operations. It should also adopt the following basic tenets for organizing, training, and equipping logistics/combat support functions:

— **Wartime Effectiveness.** The true measure of merit for logistics/combat support functions is wartime effectiveness, not peacetime efficiency. Our logistics/combat support doctrine must recognize that war is inherently inefficient.

— **Mobility.** Effective mobility includes the mental transition from a peacetime environment to a hostile, combat environment. Logistics functions must be able to precede or accompany the deployment of combat forces on short notice, anywhere in the world.

— **Adaptability.** Logistics functions must be able to adapt their organizations and procedures to the operating environment. Such adapting should allow for “nonstandard” combat organizational structures, such as composite wings, and for operations at multiple locations and in immature theaters or primitive locations.

— **Self-sufficiency.** Logistics functions must be as self-sufficient as possible. Self-sufficiency enhances the mobility and adaptability of logistics functions and promotes wartime effectiveness.

— **Self-defense.** Logistics functions must have the capability to defend themselves. Logistics personnel must be considered warriors charged with the responsibility for protecting the base and the resources necessary for combat operations.

In addition to these tenets, the new AFM 1-10 should address everyday logistics/combat support challenges and concerns. It should not be exclusively a theoretical manual but should also provide practical doctrinal guidance. Among the everyday challenges and concerns that should be discussed are:

— How the Air Force participates in the logistics support of joint and combined operations.

— The importance, advisability, necessity, and impact of host-nation support.

— The impact of operating in a “foreign” environment and the impact of combat (particularly fear, attrition, and fatigue) on logistics/combat support personnel.

— The impact, benefits, and limitations of automation on logistics/combat support operations in a combat environment.

— The need for and proper uses of logistics/combat support dedicated communications.

— The need to divide logistics/combat support capability into forward and rear components.

— The need for a reasonable balance between the standard of living within the theater of operations and direct combat operational requirements.

Like its predecessor, the development of AFM 1-10 should be an open process with inputs from as many different perspectives as feasible, not just after an initial draft is written, but from the outset. Too often, the pressure to publish results in the rejection of good ideas just because they conflict with an already chiseled-in-stone initial draft and would require some major changes. This manual should also cite historical examples and documentation to provide the rationale for the guidance presented, including the assumptions made. As the authors of the new AFM 1-1 discovered, the requirement to document doctrine tends to expose shaky propositions and strengthen the articulation of the concepts presented.

It is time for a new Air Force logistics doctrine. As AFM 1-1 states:

Doctrine should be alive—growing, evolving, and maturing. New experiences, reinterpretations of former experiences, advances in technology, changes in threats, and cultural changes can all require alterations to parts of our doctrine even as other parts remain constant.¹¹

The title of then Lieutenant Colonel William T. McDaniel’s Winter 1986 *Air Force Journal of Logistics* article said it best; it is indeed time for “a rebirth of logistics thought.”¹²

Continued on page 17

Combat Support Doctrine: Where We've Been, Where We Are, and Where We Should Be Going

Lieutenant Colonel Rodney L. Boatright, USAF

Introduction

Doctrine is an essential asset for the military profession. Emphasizing its significance, General Curtis E. LeMay described doctrine in the following way:

At the very heart of warfare lies doctrine. It represents the central beliefs for waging war in order to achieve victory. Doctrine is of the mind, a network of faith and knowledge reinforced by experience which lays the pattern for utilization of men, equipment, and tactics. It is the building material for strategy. It is fundamental to sound judgment. (14)

Since the early years of our Service, Air Force logisticians have struggled with developing logistics doctrine. Their diligent efforts have resulted in the creation of a logistics doctrine which is currently the subject of AFM 1-10. AFM 1-10, however, is called *Combat Support Doctrine* instead of *Logistics Doctrine*. And why it is called *Combat Support Doctrine* is a whole story in and of itself. In this article the terms "logistics" and "combat support" mean basically the same thing. This assumption should not be too hard to accept, since in AFM 1-10 combat support is defined as "... the art and science of creating and sustaining combat capability," which is how Admiral Eccles, the first well-known US logistics theorist, defined the objective of a logistics effort in his classic 1959 text, *Logistics in the National Defense*. But the logistics versus combat support issue is another argument and will not be covered in this article. (2:1-1;8:42)

This article is about combat support doctrine, where it is today, and where it should be headed in the immediate future. The basic premise is that the post-Desert Storm environment, combined with the recent significant changes in US military strategy and the US Air Force organizational environment, makes the present an opportune time to review and update Air Force combat support doctrine. Before explaining why this premise is true, a brief history of the development of combat support doctrine is presented, followed by a review of some doctrinal lessons from military history that may be applicable to the current situation concerning combat support doctrine. Before concluding, I will suggest some directions on how the USAF should proceed with reviewing and updating its combat support doctrine.

History of Combat Support Doctrine

The Army Air Corps made an initial attempt at air force logistics doctrine in 1943 with the development of the Army Air Corps "Logistical Manual." This manual, which was primarily a logistics planning document containing general logistics data and planning tables, actually contained few doctrinal statements. It evolved into AFM 400-5, which was discontinued in 1960 because of problems in maintaining its currency. It was followed by a similar attempt in 1957, which involved the publication of a study, "The Development of Air Logistic Doctrine 1948-1956," by Robert A. Smith, III. (16:3)

In 1955, the Advanced Logistics Course was developed at the Air Force Institute of Technology (AFIT) for the main purposes of training logisticians and developing logistics doctrine and philosophy. This course evolved into the AFIT School of Systems and Logistics. (16:4) In 1967 a thesis by a team of AFIT students identified a need for an Air Force logistics doctrine. The thesis team took on the task of ascertaining and codifying "... basic truths, principles or precepts relevant to formulation of an Air Force basic logistic doctrine." (4:9) This AFIT thesis eventually led to the development and publication of AFM 400-2, *Air Force Logistics Doctrine*, in 1968. (16:4)

The purpose of AFM 400-2 was to define basic principles and concepts for the support of aerospace forces. (5:32) Beginning in 1980, there were several proposals to revise the 1968 document and several failed attempts to publish a new doctrine. (16:4;5:32-35;15:10) A further attempt was initiated at a 1984 CROSSTALK Conference. This attempt eventually led to the publication of AFM 1-10. Apparently, the manual was entitled *Combat Support Doctrine* for the benefit of Air Force civil engineers and others who do not consider themselves logisticians, and also because the term "combat support" was not defined in JCS Pub 1 and was, therefore, available for use. (15:12) In summary, AFM 1-10 includes a definition and general description of combat support, a description of the generic combat support structure and the combat support process, and an explanation of eight basic combat support principles—objective, leadership, effectiveness, trauma/friction, balance, control, flexibility, and synchronization. (2:1-1 - 3-6)

Since AFM 1-10 was published on 1 April 1987, various critiques have either challenged it, praised it, or recommended changes. (6,9,22) However, no changes have been made since the original publication, although the Civil Engineering community published a follow-on doctrinal manual—AFM 3-2, *Civil Engineering Combat Support Doctrine*. The civil engineering doctrinal manual was developed in 1991 to explain the relationship of the air base and the engineer to aerospace power and provide guiding precepts for Air Force leaders and engineers. (3:1)

In recent years, progress has been made in the development and assessment of doctrine for the logistics support of joint operations. In line with the recent increase in the importance of jointness, joint logistics doctrine has been developed and published by the Joint Staff in Joint Test Pub 4-0, *Doctrine for Logistic Support of Joint Operations*. This new joint logistics doctrine identifies the basic logistic principles as responsiveness, simplicity, flexibility, economy, attainability, sustainability, and survivability, which are somewhat different from the combat support principles in AFM 1-10. (13,17)

Lessons From the History of Operational Doctrine

According to the lead paragraph of AFM 1-10, doctrine "... offers guidance to be used by Air Force leaders to: (1) learn from

the past, (2) act in the present and influence the future.” (2:iii) If it does nothing else, this point begs a question about whether or not lessons of the past might help as we try to determine where we should be headed with combat support doctrine. The problem is that Air Force combat support doctrine has a relatively short history. But the history of the operational art of war as it relates to doctrine is not short, and it may provide some applicable lessons. Upon review of this history, one particular thought becomes quite clear: There are doctrinal lessons that show up when one reviews the histories of particular wars; however, for a variety of reasons, military leaders have frequently failed to properly learn those lessons and to revise faulty doctrine where necessary. In some cases these failures have led to rather significant disasters in later conflicts.

For example, one of the important doctrinal lessons that should have been learned from the American Civil War was, given the improvements that had been made in firepower, frontal assaults by infantry against fixed fortifications were likely to result in disastrous losses. (23:419) Before the end of the nineteenth century, a very similar lesson showed up again in the Anglo-Boer War in South Africa. (12:516) In spite of these lessons, and the fact that there had been even more significant technological improvements in firepower, armies (most notably the French) still entered World War I with doctrines relying on frontal infantry assaults. And of course, the horrifying results on the French frontier in 1914 are still well etched in the memories of military historians. (12:520-526)

Another more recent example of a failure to pay attention to doctrinal lessons of warfare has to do with the ever controversial subject of command and control of air power. A lesson of World War II, particularly the war in North Africa, was that to be most effective “. . . air power must be centrally controlled and employed by an air commander.” (1:A-2 - A-3) Problems with the command and control of US air power during the Vietnam War, however, indicate a definite failure to carry this lesson forward to that particular conflict. Especially during the Rolling Thunder Campaigns, the absence of a single air commander led to chaos and less-than-effective results. (7:128)

It would not take a great deal more research to come up with similar historical examples, but the point should be clear. Following a war, doctrine must be reviewed to determine how it might be revised to accommodate the lessons of the conflict; and this review/revision must be carried through to ensure that the appropriate doctrinal changes are fully documented and implemented.

An Opportune Time to Review and Possibly Revise Combat Support Doctrine

So what does all of this have to do with combat support doctrine and the present situation? A 1989 Air War College study of combat support doctrine pointed out that, “For a doctrine to be viable it must be tested”; and, at that particular time, Air Force combat support doctrine had not been tested. (18:32) That is obviously no longer the case. We should be able to view Operation Desert Shield/Storm as an excellent test of the existing combat support doctrine. After all, this operation was one of the largest and most complicated logistical undertakings the US Air Force has experienced since becoming a separate service. This fact alone should make it clear that the lessons learned from Desert Shield/Storm provide a unique opportunity to assess combat support doctrine and revise the doctrine if necessary. In fact, assessing the doctrine based on the wartime lessons is necessary to ensure that related mistakes from the history of

operational doctrine can be avoided. The Desert Shield/Storm logistics lessons were recently published in the Fall and Winter issues of the Journal as a result of an Air Force Logistics Management Center* (AFLMC) project. (10:1-2) Whatever else is done with the results of these important efforts, if we are serious about having a viable combat support doctrine, we must ensure that the results form the basis of a review/revision of AFM 1-10.

In addition to the results of Desert Shield/Storm, other factors make the present an opportune time to review and revise combat support doctrine. One is the fact that US military strategy is experiencing a monumental change. Primarily due to the collapse of the Soviet Union, US military strategy has evolved from a strategy based on containment to one based on power projection, with an emphasis on potential regional contingencies. (19:21:29) A rather well-accepted concept, that has been proven in the past, is that strategy and logistics are intimately related. This is one of the most significant concepts that Eccles developed in *Logistics in the National Defense*. He provides several examples in his book that illustrate the importance of this relationship. (8:30-41) Given this intimate logistics-strategy relationship, and the significant and ongoing changes in US military strategy, it should clearly follow that our basic logistics concepts may also be due for changes. These strategy changes, combined with the drawdown in the size of our military forces, have already had major impacts on Air Force logistics in the form of organizational changes that significantly affect logistics and combat support. (24:2-11)

If we accept the fact that AFM 1-10 is an important document that should provide the basis for how we support Air Force systems, then the urgent need for a review and revision of the manual should be evident. In fact, this is a must if logistics is to stay abreast of strategy. Furthermore, this should be accomplished before the strategy and operationally related changes progress too far. The process that calls for completing a strategy or an operational plan and then turning it over to logisticians to work out the support details has been tried before, to the consternation of the affected logisticians. History has taught us this is not the best way to operate or to plan. Logistics planning and preparations must be conducted concurrently with strategy development and operational planning. (13:II-1) Alluding to this necessity, Eccles wrote:

“. . . once a commander thinks of the strategic, logistical, and tactical elements as individual or isolated matters he has lost his perspective.” (8:20-21)

Another factor calling for a review and revision of Air Force combat support doctrine is the recent progress in the development of joint logistics doctrine. Joint logistics doctrine had not been developed when AFM 1-10 was published. Now that it exists, there should be an effort to ensure more congruence between the two doctrines. After all, ultimately Air Force combat support doctrine is about the logistics support of the aerospace component of joint forces assigned to unified and specified commands. Furthermore, we are seeing an increase in the involvement of the joint community in logistics functions that were the sole responsibility of the Services in the past. The involvement of the Joint Requirements Oversight Council (JROC) in the acquisition of weapon systems is just one example. All of this points to a need to try to bring the two doctrines closer together. A review of the basic principles of both doctrines indicates there is work to be done to ensure more agreement between the two.

*(Now Air Force Logistics Management Agency)

Where Do We Go From Here?

The first step required to form the basis of a thorough review and revision of Air Force combat support doctrine has already been initiated—the development of logistics lessons learned from Desert Shield/Storm. (10:1) Now that the identification of these lessons learned has been completed, a working group should be formed to determine how Air Force combat support doctrine should be changed based on the lessons. Experiences from the group formed in 1985 to develop the initial combat support doctrine should provide some useful background for organizing and conducting the working group. (15) The group should represent an organizational cross section of the Air Force and include representation of organizations that had significant involvement in the logistics support of Desert Shield/Storm.

In addition to revising combat support doctrine based on lessons from Desert Shield/Storm, the working group should also focus on updating the doctrine so it is in concert with the new national military strategy. More so than at any other time in the past, the new national military strategy, based primarily on rapid deployment and power projection, is going to demand that both our weapon systems and the logistics systems required to support them are highly mobile. The likelihood that fewer defense dollars will be available for building a significantly larger strategic lift capability makes this point even more critical. As the working group reviews and revises the doctrine, this concept of a more mobile force with a more mobile logistics structure should be viewed as one of the most important and basic foundations of our future logistics systems.

Furthermore, our combat support doctrine should give serious consideration to concepts that can help reduce wartime lift requirements such as host-nation support and prepositioning. Evidence indicates that host-nation support was extremely beneficial during the Gulf War and will most likely be important in future conflicts. Prepositioning was also important to Gulf War logistics successes. However, since the potential location of our next military engagement is now less predictable than in the past, prepositioning is likely to be a more complicated proposition. More afloat prepositioning may be a possible answer. (11:7-8)

The group should also devote some attention to a new concept called “reconstitution,” which is now a part of our national military strategy. Reconstitution refers to the rebuilding of military forces that would have to take place after the drawdown in response to a strategic warning of a significant increase in the threat. Logistics and combat support would be key factors in such a buildup. (19:25) Addressing the significance of reconstitution with respect to logistics in the US Army, General Carl Vuono wrote:

Logisticians must be particularly cognizant of reconstitution, not only from a force structure standpoint but also with a clear recognition of the supplies, equipment, and services that mobilization demands. (21:29)

Reconstitution is likely to be just as important to logistics or combat support in the Air Force.

In addition, as the working group carries out this project, they should consider the recently developed joint logistics doctrine and focus on developing a Service combat support doctrine that is consistent with the new joint doctrine. To help in this effort, representatives from the Joint Staff who have responsibilities for joint logistics doctrine should participate in the working group.

As the review and revision of Air Force combat support doctrine proceeds, some caution will be necessary in a few areas. First of all, there is likely to be a tendency to view the results of Gulf War logistics efforts in a purely positive light. Admiral Harry D. Train II somewhat sarcastically wrote about a particular phenomenon we should remain conscious of:

... the normal baggage of American human nature that prefers being ruined by praise to being saved by criticism. (20:50)

The logistics accomplishments during the war have already received high praise and rightfully so because the logistics support of Desert Shield/Storm truly was a massive undertaking. Logistics has been identified as “. . . the essential element in projecting military power into the area of operations.” (21:28) While our logisticians are extremely deserving of the high praise and can be proud of their efforts, they should be cautious of the tendency to get so carried away with the positive aspects that they overlook the mistakes that were made, or the potentially avoidable problems that occurred. This general tendency could very well be one of the main reasons why the history of warfare shows that learning and applying doctrinal lessons of wars is not always that easy. Should learning and applying doctrinal lessons relating to combat support be any easier? Let’s hope so.

Caution should also be exercised with regard to how the logistics lessons learned are organized and analyzed. While something certainly may be gained from organizing the lessons into functional logistics or combat support areas, such as maintenance, transportation, supply, contracting, etc., the significant lessons should also be viewed from the aspect of the total logistics or combat support system. This is especially true if we hope to be able to apply the lessons learned to Air Force combat support doctrine which rightfully describes our entire combat support system from a broad, systemic perspective.

Conclusion

Whether it be doctrine for operations, combat support, or some other branch or function of the military, doctrine is absolutely necessary to provide the general direction and guidelines for how we operate or provide support to combat forces. However, doctrine cannot remain useful if it is not revised based on studying lessons learned and keeping pace with the times.

When Air Force Combat Support Doctrine was developed and published in AFM 1-10, it was a major accomplishment for Air Force logisticians. While there may be many differences of opinion about exactly what the doctrine should include, it clearly provides a comprehensive foundation for educating and training Air Force logisticians and for organizing, equipping, and sustaining aerospace forces for war. (2:iii) We owe it to those who developed this doctrine, and especially to the future Air Force logistics community, to continue to build on this foundation.

In his foreword to *Civil Engineering Combat Support Doctrine*, Major General Joseph A. Ahearn wrote:

Doctrine is not static. It must be periodically reviewed and updated to keep it relevant in light of changing threats, technologies, operational strategies, and Air Force Doctrine. To support the dynamic nature of doctrine, personnel should recommend changes when factors make doctrinal precepts obsolete. (3)

The logistics lessons learned from the recent Gulf War experience, combined with the significant changes taking place in today's military, create an environment that demands a thorough review and revision of AFM 1-10. Because logistics is such a critical factor in modern warfare, whether or not we satisfy this demand today could have a great deal to do with the results of future conflicts that may involve US aerospace forces.

References

1. Air Force Manual 1-1, *Basic Aerospace Doctrine of the United States Air Force*, Department of the Air Force, Headquarters US Air Force, Washington DC, 16 March 1984.
2. Air Force Manual 1-10, *Combat Support Doctrine*, Department of the Air Force, Headquarters US Air Force, Washington DC, 1 April 1987.
3. Air Force Manual 3-2, *Civil Engineering Combat Support Doctrine*, Department of the Air Force, Headquarters US Air Force, Washington DC, 26 April 1991.
4. Aronovsky, Lieutenant Colonel Alvin, and Cole, Major James. *A Study for the Development of an Air Force Basic Logistic Doctrine*, Wright-Patterson Air Force Base OH, School of Systems and Logistics, Air Force Institute of Technology, 1967.
5. Badalamente, Richard V. "The Air Force Reexamines Its Logistics Doctrine" *Logistics Spectrum*, Spring 1981, pp. 32-35.
6. Berle, Terence H. *Thoughts on Combat Support Doctrine*, unpublished and undated paper.
7. Clodfelter, Mark. *The Limits of Air Power*, New York NY: The Free Press, 1989.
8. Eccles, Henry E. *Logistics in the National Defense*, Harrisburg PA: The Stockpole Company, 1959.
9. Green, Major Michael C. "Some Thoughts on Combat Support Doctrine (AFM 1-10)," *Air Force Journal of Logistics*, Fall 1988, pp. 4-6.
10. Hagel, Major Stephen. "Capturing Logistics Data," *Air Force Journal of Logistics*, Fall 1991, pp. 1-2, and Winter 1992, pp. 1-9.
11. Harold, Captain Brent; Sims, Major Marc; and McNeely, Lieutenant Commander Donald. "Operation Desert Shield: Logistics Considerations for Sustained Deployment," *Logistics Spectrum*, Spring 1991, pp. 5-9.
12. Howard, Michael. "Men Against Fire: The Doctrine of the Offensive in 1914," *Makers of Modern Strategy*, edited by Peter Paret, Princeton NJ, Princeton University Press, 1986, pp. 510-526.

13. Joint Test Pub 4-0, *Doctrine for Logistic Support of Joint Operations*, The Joint Staff, Washington DC, June 1990.
14. LeMay, General Curtis E. 1968 quote at the beginning of Air Force Manual 1-1, *Basic Aerospace Doctrine of the United States Air Force*, Department of the Air Force, Headquarters US Air Force, Washington DC, 16 March 1984.
15. McDaniel, Lieutenant Colonel William T., Jr. "The Doctrinal Challenge: A Rebirth of Logistics Thought," *Air Force Journal of Logistics*, Winter 1986, pp. 10-18.
16. McMahon, Lieutenant Colonel Gary. *Air Force Logistics Doctrine: Where is it?* Air War College, Air University, Maxwell Air Force Base AL, 1985.
17. Patrow, Lieutenant Colonel Michael L., and Abbot, Captain James L., III. *Doctrine for Logistic Support of Joint Operations (Draft JCS Pub 4-0)*, The Industrial College of the Armed Forces, Fort McNair DC, 1989.
18. Reynolds, Lieutenant Colonel Dennis. *Combat Support Doctrine: Guidance or Hindrance?* Air War College, Air University, Maxwell Air Force Base AL, 1989.
19. *The National Military Strategy*, The Joint Chiefs of Staff, Washington DC, 1992.
20. Train, Harry D. II. "An Analysis of the Falkland/Malvinas Islands Campaign," *Naval War College Review*, Vol. XI, No. 1, Winter 1983, pp. 33-50.
21. Vuono, General Carl E. "Desert Storm and Future Logistics Challenges," *Army Logistician*, July-August 1991, pp. 28-31.
22. Wegemer, Major Teresa Y. "Combat Support Doctrine: Another Point of View," *Air Force Journal of Logistics*, Fall 1988, pp. 6-7.
23. Weigley, Russell F. "American Strategy from Its Beginnings through the First World War," *Makers of Modern Strategy*, edited by Peter Paret, Princeton NJ, Princeton University Press, 1986, pp. 408-443.
24. *White Paper, Air Force Restructure*, Pentagon, Washington DC, September 1991.

Lieutenant Colonel Boatright wrote this article while a student at Air War College, Maxwell AFB AL. He is presently Deputy Commander, 49th Base Systems Group, Holloman AFB, New Mexico.



Continued from page 13

Notes

¹Green, Maj Michael C., USAF. "Some Thoughts on Combat Support Doctrine (AFM 1-10)," *Air Force Journal of Logistics*, Fall 1988, pp. 4-6.

²AFM 400-2, *Air Force Logistics Doctrine*, 1 November 1968.

³Myers, Maj Grover E., USAF. *Aerospace Power: The Case for Indivisible Application* (Maxwell AFB AL: Air University Press, 1986).

⁴AFR 1-2, *Assignment of Responsibilities for Development of Aerospace Doctrine*, 10 September 1990, p. 4.

⁵Alexander, Maj Gen Robert M., USAF, Director of Plans, Deputy Chief of Staff, Plans and Operations, HQ USAF, letter, subject: "Combat Support Doctrine," 6 July 1990.

⁶Campbell, Maj Gen H. N., USAF, Assistant Deputy Chief of Staff, Logistics and Engineering, HQ USAF, letter, subject: "Air Force Doctrine," 7 February 1991.

⁷Joint Test Pub 4-0, *Doctrine for Logistic Support of Joint Operations*, June 1990, pp. iv, I-1 and 2, and IV-1 thru IV-4.

⁸Joint Pub 0-2, *Unified Action Armed Forces (UNAAF)*, 1 December 1986, p. 3-68.

⁹AFM 1-1, *Basic Aerospace Doctrine of the United States Air Force*, Volume II, March 1992, pp. 199-200.

¹⁰Much of the material presented in the rest of this article is a summary of AUCADRE/RI responses to the letters identified in notes 5 and 6. The author is indebted to the members of the Airpower Research Institute who helped develop these ideas, particularly Lt Col Price Bingham.

¹¹AFM 1-1, Volume I, p. vii.

¹²McDaniel, Lt Col William T. Jr., USAF. "The Doctrinal Challenge: A Rebirth of Logistics Thought," *Air Force Journal of Logistics*, Winter 1986, p. 10.

¹³Joint Pub 1-01, *Joint Doctrine and Joint Tactics, Techniques, and Procedures Development Program*, with Changes 1 and 2, 15 April 1988, pp. VI-12 and 13.

Lt Col William F. Furr is presently a Military Doctrine Analyst; Airpower Research Institute; Center for Aerospace Doctrine, Research, and Education; Maxwell AFB, Alabama.



The Gulf War and Logistics Doctrine

Wing Commander Gary Waters, RAAF

The conduct of air operations in the Gulf War, characterised by modern technology and guided by contemporary doctrine, surprised and astounded many of air power's detractors, especially those who had failed to keep abreast of developments in doctrine. However, the preparedness (readiness and sustainability)¹ of allied forces for combat during the Gulf War rested largely on logistics. That is to say that logistics provided the physical support for air operations to be mounted and sustained.²

This paper discusses some of the essential doctrinal issues which should be examined as part of the Royal Australian Air Force's (RAAF) analysis of the air war. I was employed at the RAAF's Air Power Studies Centre to analyze the Gulf War, with implications for the further development of RAAF doctrine. My observations of logistics represent only one small part of the overall study. In particular, the issues discussed encompass support from industry and the civilian sector for military logistics; logistics requirements for operational deployments; the need for an integrated logistics system; the effect of prepositioning stocks; transportation; maintenance; and stockholdings and spares support.

While the logistics orientation in Australia centres around support for air operations in the air-sea gap to the north and northwest of Australia, it must retain the flexibility to react to other contingencies. For example, the United Kingdom (UK) deployment to the Gulf—Operation Granby—was totally unforeseen, yet the flexibility and adaptability of the UK's operational logistics system allowed it to be tailored to a new set of requirements.

In Support of Military Logistics

The Gulf War witnessed high levels of logistics support between allies; for example, Sweden and Romania provided direct assistance to the UK in terms of medical facilities, supplies, and personnel. Many countries within the Persian Gulf provided substantial support for supply of fuel, water, and food, and also provided facilities for the employment and maintenance of aircraft.

The large number of Saudi airfields was touted as an element of luck for the allies; yet, in almost any theatre, large numbers of airfields would exist. Moreover, the infrastructure to support a major air campaign would also exist. The appointment of some Saudi bases certainly made the launching of air operations that much easier, but the absence of many services would not have stopped the conduct of air operations.

Civilian support of the war effort was considerable. For example, British Aerospace (BAe) civilian contractors in Saudi Arabia provided technical and spares support for deployed Royal Air Force (RAF) forces; and many US contractors sent teams to the Gulf to provide in-theatre support, especially for maintenance and system enhancement. The base at Dhahran housed Royal Saudi Air Force (RSAF) Tornados, supported by British Aerospace personnel and many ex-RAF (as well as some ex-RAAF) personnel. While the logistics task for the RAF

was a formidable one, nevertheless it was eased because of civilian support.

In addition to direct civilian support, the industrial bases of the allied nations were also very important to the war effort; and, while expectations were largely met, not all requirements could be satisfied in terms of time or quantity. The prime example was in supplying US forces with certain rations, for which war reserves were not held. Similarly, supply of 120-mm tank ammunition, desert camouflage clothing, and boots posed severe problems.

Until September 1990, there had not been any requirement for desert boots and clothing. During the crisis, 124,000 pairs of boots were being produced each month. Production of desert camouflage clothing went from 0 to 376,000 sets per month, over a six-month period. Additionally, production of chemical protective clothing increased from 33,000 sets per month, before Operation Desert Shield, to 70,000 per month during the crisis.³

Many debuts were made by new technology in the War; some were in developmental stages, such as Joint Surveillance Target Attack Radar System (J-STARS) aircraft, Thermal Imager and Laser Designator (TIALD) pods, GBU-28s, and Stand-off Land Attack Missiles (SLAM). These all required significant levels of support from the civilian sector, with some contractor personnel being positioned in-theatre, and, in the case of the two J-STARS aircraft, even on-board. Furthermore, procedures for the provision of spares support and maintenance for these new systems had to be adaptable and responsive.

Australia's policy of self-reliance expects industry to expand when necessary and the air defense force (ADF) to similarly surge. Such capabilities are not cost-free and government incentives are needed to give substance to the concept of an expansion base. Without these capabilities for expansion, the policy of self-reliance stands as a hollow shell. The logistics system must be capable of coping with expansion, being worked harder, gaining the most from civilian resources and resources of allies, and retaining resilience.

Deployments

Deployment to and rapid reinforcement of bare air bases in Australia, such as Learmonth, Curtin, and Scherger (when constructed), have been argued as likely events for the RAAF in defence of Australia contingencies. However, it is more likely that any deployments would be outside Australia to assist regional allies or to assist UN peacekeeping forces even farther afield. While it may be impractical and politically unacceptable for the RAAF to practise such forward deployments, contingency plans could still be prepared and practised in the form of Command Post Exercises. The recurring logistics lesson from the recent UK experience with Operation Corporate (the Falklands deployment) and Operation Granby has been that logistics requirements will be for operations in areas not planned for.

Gulf deployments depended heavily on extensive lateral support from other theatres, such as European Command (EUCOM), and on airlift availability to transport high-priority

items, just to overcome normal peacetime deficiencies, let alone increased combat sustainability requirements.⁴ Host-nation support was provided by Saudi Arabia for fuel, transportation, food, water, and accommodation facilities.

While the provision of host-nation and lateral support helped the US particularly, the allies had a considerable amount of time to accomplish their logistics objectives without compromising combat objectives. This meant that during the deployment phase, allied combat units were not displaced by support units in the limited strategic transport that was available.

Deployments to remote locations often carry with them requirements for road building and repairs, building maintenance, catering, office accommodation, and domestic housing. In the Gulf, these were all provided by the Civil Engineering and Community Services Support personnel of the United States. They erected over 5,000 tents, built over 100,000 square metres of hard wall, laid over 500,000 square metres of concrete and asphalt, and served over 20 million meals to the 55,000 personnel deployed in-theatre.⁵ Over 1,200 US aircraft and personnel had to be "bedded down" by Civil Engineering and Community Services. They represented 9% of all personnel deployed and built one base from scratch in 40 days, involving 380 tents, 4 field kitchens, a 50-bed hospital, a field laundry, 19 latrine/shower units, and a field exchange.⁶ They also had to bring in electrical power supplies.

The Logistics System

The logistics task of the RAAF is to comply with government direction to achieve economies of scale by reducing duplication of support and services. That is to say that, where appropriate, civilian resources should be used and ADF-wide functions should be rationalised. However, the RAAF logistics system still has a requirement to provide a unique service which must be tailored to its air operations. An important observation must be the need to balance war reserves and organic military production with realistic capabilities of the civilian industrial base.

Automation of logistics systems used in the Gulf proved to be a contributing factor to the allies' ability to cope with a deluge of requirements and logistics problems, and to manage the unusual. Any logistics system must be able to arm, fuel, fix, move, and sustain personnel. These tasks are embodied in US doctrine and facilitate the generation of combat power, specifically in relation to the AirLand Battle.⁷ US doctrine goes further and argues that imperatives for sustaining combat operations include anticipation, integration, continuity, responsiveness, and improvisation.⁸

Integration embodies synchronising the many elements of logistics, and anticipation demands real-time communications and automated systems. It is time for Australia to translate real-time combat operations to the logistics field and achieve a continuity that can truly sustain combat air operations. Responsiveness must be tied to high mobility, reliable distribution, advanced maintenance (including diagnostics and repair), and computer-based decision support systems. In the Gulf War, integration of logistics with operations was shown to enhance agility and endurance; thus, most RAAF logistics functions should be integrated into the operational commander's battle plan.

Continuity requires multifunctional support, which means all elements of logistics and other sustainment roles⁹ should be brought together and oriented to the operational commander's plan. Rapid reinforcement or replacement of any sustainment element must be factored in to the operational plan.

Responsiveness of logistics to operational requirements will be improved if all sustainment functions can be incorporated into the single command and control (C²) chain and real-time visibility can be afforded. This will not eliminate the need for innovation and improvisation, but it will avoid any semblance of "ad hocery."

The US Army fielded a logistics system which provided "a distributed, survivable and fully-integrated supply system from the direct support unit through theatre level."¹⁰ The system was designed to support independently deployed forces, yet provide asset visibility at division and corps level. An automated air-loading system was also used which "reduced days of manual effort to hours of automated processing."¹¹ The automated logistics systems had never been deployed in wartime; and the initial locations used were austere, with limited communications and generator-supplied electricity. Requisitions overloaded the systems initially, which increased resupply times. Reliable tactical logistics automation proved to be essential to keep pace with the highly-maneuvrable combat forces.

During Desert Shield/Storm, logistics planning was embodied within operational planning. From the UK's perspective, this was an important conceptual step. During the Falklands campaign, logistics was grouped with personnel for its higher level management. This did not happen in the Gulf War, where logistics was firmly ensconced as part of combat operations. Not only does such a command and control link enhance the responsiveness of the logistics system to operations, but it also provides the logisticians with a far better view of the operational implications of their logistics decisions.

Prepositioning

Responsiveness, and hence sufficient airlift and use of prepositioned equipment and consumables, underwrote the success of the allied air effort. Prepositioning of certain items of equipment and stocks allowed the allies to deploy to the Gulf immediately. Responsiveness is one thing, but the ability to sustain is quite another. Air power has proven to be responsive; but its sustainability depends on logistics support, which in Australia's case, where operations may be conducted from bare bases, would necessitate prepositioning to lessen the load on airlift and other surface forms of transport.

Saudi Arabia had bases built, stocked, and prepared for war,¹² which allowed the allies to deploy and move immediately to a combat footing. Other areas offered only runways. In these cases, engineers built modular cities from tents, prefabricated buildings, and other materials that had already been prepared for erection in austere locations. Prepositioning of fuel, equipment, supplies, vehicles, and munitions saved an estimated 1,800 airlift missions¹³ and equipped 21 airfields. Gulf Co-operation Council (GCC) countries also provided fuel and other materials. While host-nation support proved fundamental to the success of logistics, initial negotiations were beset with problems, which illustrated that host-nation contract procedures need to be in-place during peacetime.

Approximately \$1 billion worth of predominantly domestic stores, ammunition, and fuel had been prepositioned by the US in Saudi Arabia. While valuable lessons were derived from prepositioning, the value of prepositioning, as with most things, does vary with circumstances. Modernisation and maintenance of storage facilities consume proportionally more effort as time progresses. Moreover, large fixed storage sites, or even sites afloat, offer attractive targets. Undoubtedly, government-to-

government agreements for prepositioning are made easier if common equipment is used by both nations.

The US also prepositioned stores on ships at Diego Garcia and Guam, and within 10 days of mobilisation, they were in-theatre. Two US Marine Corps (USMC) Expeditionary Brigades were in-place by 27 August, complete with tanks, helicopters, and fixed-wing aircraft. Each brigade used four prepositioned ships to carry its equipment, which meant that only 250 air transport flights were required to move the troops, rather than the 3,000 normally required to move all the equipment.

The RAF did not preposition stocks in Saudi Arabia and had to rely extensively on host-nation support. The effect was that the RAF could not rely on the same levels of support at all bases, whereas the US was able to use its prepositioned equipment and stores to augment host-nation support. This must be a valuable observation for Australia in any future deployment to assist in regional troubles.

While military operations in Australia, and hence logistics support, will depend on elements of national infrastructure, there will be occasions when civil support is not forthcoming or unable to be provided in time. The *RAAF Air Power Manual* discusses such essential infrastructure elements as transportation, communications, production, and supply. Production includes civil engineering, provision of facilities, and works and services associated with those facilities. Supply includes the provision of spares, major equipment, food, water, and fuel for energy.¹⁴

Although host nations in the Gulf provided elements of these infrastructure requirements, much was organic to the forces deployed. Electricity generators, water-purification plants, and food were brought in by the UK; and UK forces had to build tent lines and ramps, while the US engineering support services built up bare bases.

Transportation

Sealift met 90% of the US's strategic transport requirements and moved 86% of the ammunition, equipment, and stores to support UK forces.¹⁵ Not only was sealift required, but additional airlift was needed to provide sufficient carrying capacity to satisfy all requirements. Therefore, the US relied on the Civil Reserve Air Fleet (CRAF) and the UK on the Royal Auxiliary Air Force (RAuxAF). Consequently, detailed plans for the use of civil transport, both sea and air, during contingencies should be viewed by Australia as essential.

The RAF and RAuxAF carried up to 500 tonnes of airfreight daily,¹⁶ and 8,000 dedicated freight flights were flown from Akrotiri, Cyprus. The airlift movements by the UK during Operation Granby equated to almost 10 years of activity at normal peacetime rates.¹⁷

Airlift assets were in short supply, exacerbated by many deploying units affording high priorities to requisitions which demanded use of airlift. For example, one unit requested airlift of 15,000 pounds (almost 7,000 kgs) of insect repellent.¹⁸ As more units deployed and others required resupply, demands on airlift increased even more. The movement priorities for much equipment and supplies had to be downgraded for movement by sea. The supply of critical repair items was being held up, so the "Desert Express" was implemented to bypass the regular airlift system. It was limited to repair parts and medical items only, and each US Service was allocated space on the daily flights. Importantly, though, US units not in-theatre reduced their demands on the overall logistics system so resupply could be effected more readily to deployed units.

Predominantly civilian-manned depots in the US rose to the challenge of the Desert Shield deployment and worked "around the clock, seven days a week."¹⁹ The civilian transport system also swung into action. To offset shortages of transportation, trucks and trailers were unloaded rapidly, often overwhelming the ability of receiving bases to move the supplies before the next shipment arrived.

Once supplies arrived in the Gulf, the problem of internal distribution then had to be met. Lack of roads, railways, airfields, ports, and storage facilities placed a tremendous strain on the military logistics system. Once the ground war started, the logistics support for the allied forces, which conducted the left hook, west of the Wadi al Batin, and advanced 300 kilometres, was enormous. One report indicated a daily convoy of trucks extending for 40 miles.²⁰

Maintenance

The maintenance effort in the Gulf responded to wartime demands, and higher aircraft utilisation rates were achieved than in peacetime. This occurred in a harsh operating environment, where equipment was being used well in excess of peacetime rates. Adaptability of systems, innovative practices by ground crew, contingency maintenance, battle damage repair practices, and high levels of contractor support, both in-theatre and at home, all contributed. These are some of the observations which the RAAF should take from the Gulf War.

Some of the problems experienced by the first Tornado Squadrons which deployed included tyres bursting and high cockpit temperatures. High temperature tyres were fitted to solve the first problem. In solving the second, the Saudis provided a cooling system to stop the electronics from overheating whilst the aircraft was on the ground. Despite these and other initial problems, maintenance facilities and procedures were quickly in-place and were well-supported by British Aerospace technicians who were still servicing RSAF Tornados.

Maintenance lessons from desert operations emerged early—such as wiping wheel struts after each flight to prevent sand finding its way into hydraulic parts; flushing water through engines regularly to prevent corrosion; and cleaning cockpits thoroughly to keep sand and dust out of the electronics systems.

Battle damage repair (BDR) was reasonably effective. For example, after a C-130 wing was damaged by a helicopter, a blanking plate and another wing were fitted; and the C-130 was able to be flown back to the UK. Additionally, some Jaguars returned to base with considerable damage inflicted as a result of direct hits from shoulder launched surface-to-air missiles (SAMs), but were able to continue flying due to BDR. An RAF Tornado GR1 suffered a bird strike during an attack against Jarrah airfield. A large section of the port wing's leading edge was missing and after BDR was effected at Muharraq in Bahrain, the aircraft was flown to Bruggen, Germany, for repair. Three days later, it was back in-theatre and went on to complete 35 missions.²¹

Maintenance practices varied, with the USAF performing in-theatre maintenance of F-15s every 100 and 600 hours, whereas RAF Tornados were rotated back to the UK.²² Additionally, some unserviceabilities were carried which would not be carried in peacetime. This again showed a flexibility in maintenance which is critical once combat has been joined.

Contingency servicing and modified NATO maintenance schedules were used in-theatre to reduce the impact of the increased tempo of operations. Despite this, the RAF still had to "gut" many units to maintain war establishments at 2 to 2½

times that of peacetime establishments. Eventually, all Tornados flying in the UK and Germany had to cease; and stores and aircraft maintenance depots were denuded of spares and military manpower.

RAF C-130s flew 1.7 times their normal rate; and basic servicing, such as cleaning, were relaxed. Second-line maintenance had to be doubled and first-line maintenance increased by 25%. Maintenance of RAF C-130s in the UK was helped by the transfer of Phantom servicing personnel to C-130 Hercules servicing which allowed C-130s to be "turned around" in one-third of the normal time.²³

Extensive modification programmes were implemented to update the Tornado F3 and GR1. For example, the GR1s underwent, on average, 18 modifications and 13 special trial fits (STF), including radar absorbent material (RAM) and surface wave absorbent material (SWAM) fitted to leading edges and weapon pylons. The Mk 12 Mode 4 IFF and larger fuel tanks were fitted, and buddy-buddy refueling pods (Sargent-Fletcher type) were fitted in case of air-to-air refueling (AAR) emergencies. Aircraft also received the "Pink Panther" desert camouflage paint.²⁴

When the firing of AIM-9 Sidewinder missiles was found to cause pitting of the aluminium leading edges, nickel-chrome ones were fitted to Tornado GR1 and F3 taileron leading edges.²⁵ Helicopters also received modification, with Chinooks for example being modified to accommodate flash-suppressors for mini guns and special chutes to catch spent cartridges to prevent them from being ingested into rotor blades.

Mission capable rates²⁶ and average sortie duration (expressed in hours) increased for all aircraft over their respective peacetime rates. As an indication, some examples are:

AIRCRAFT	MISSION CAPABLE RATE		AVERAGE SORTIE DURATION	
	PEACE	WAR	PEACE	WAR
Tankers				
KC-135s	86%	89%		
KC-10s	95%	95% ²⁷		
Transport Aircraft				
C-5	69%	78%	1.8	10.3
C-141	80%	86%	3.2	11.9
C-130	78%	84%	1.7	4.6 ²⁸
Combat Aircraft				
F-15C/D	85.1%	93.7%	1.36	5.32
F-15E	80.4%	95.5%	1.68	3.27
F-16	90.2%	95.4%	1.49	3.24
A-10	90.4%	95.5%	1.58	2.37
F-117	81.8%	85.8%	1.55	5.20
F-4G	83.7%	88.7%	1.34	3.71 ²⁹

Readiness rates and maintenance of helicopter fleets were also impressive. The Apache was designed to fight in the central European theatre, yet adapted well to fight in the desert. This must surely be the secret to success in combat—ingenuity on the part of ground crews to ensure maintenance, logistics, and other sustainment functions work. Readiness rates had been funded to 70% to 75% in peacetime, yet during Desert Shield they reached 80%, and in Desert Storm, 90%. Fourteen hours per month was regarded as a normal flying rate for the Apaches in peacetime. This increased to 15.2 hours during Desert Shield and to 18.3 hours during Desert Storm. Further increases during Desert Shield had to be capped to preserve assets for the expected increase in tempo during Desert Storm.

Stockholdings and Spares Support

Technology has placed greater demands on the logistics system. For example, sophisticated weapons and systems, because of cost, tend to be procured in minimal quantities for resupply, yet are consumed just as quickly in combat as those they replace. Moreover, lower production rates mean that exhausted stocks cannot be resupplied quickly.

For the UK, stocks of weapons were low and replenishment programmes were not in-place. That is, contracts had not been let for replacement of war stocks. The six-day concept of war stockholdings for a NATO war was found wanting in the Gulf theatre. Lack of adequate numbers of weapons can affect tactics; and, as the war progressed, only partial weapon loads could be carried in some instances.

Stocks of spare parts included a safety margin which allowed for the harsher operating environment, the extended lines of communication, and the operational consequences of stock-outs. In many instances, civilian industry had to respond quickly and dramatically to provide sufficient quantities. The supply of spare parts for grounded aircraft in the US would take around three days to deliver. In the Gulf, they arrived in 48 hours, using a high-priority delivery service, known as the "Desert Express."

Protective packaging was needed in great quantities to protect supplies from ingress of fine sand. This had a flow-on effect in that additional equipment had to be purchased to provide the additional packaging, which added to the logistics costs. Demands for stocks of containers were also unprecedented; and, within three months, the increased demand had "taken up most of the slack in a fortuitously depressed European market."³⁰

Importantly, US logistics was not provided through a "push" system as it had been in the Vietnam War, where equipment and spares were delivered to the theatre of war simply because they were available. In the Gulf War, logistics was provided through a "pull" system, which saw equipment and spares being delivered only to satisfy in-theatre requirements.³¹ The USAF's stock control and distribution system had to be upgraded quickly to provide an automatic facility for flagging items destined for the Gulf to afford them priority treatment.³²

Use of Tabuk airfield posed significant logistics problems. Fuel had to be transported by road from the port of Yanbu, a round trip of some 1,850 kilometres which took each tanker four days to make. As part of the host-nation agreement, Saudi Arabia provided 800 general-purpose trucks and 5,000 tankers and trucks to distribute Saudi fuel to the allies, free of charge.³³

The Royal Engineers were required to provide emergency bulk fuel installations at the four airfields used by the RAF and construct 42 steel tanks which provided an additional storage capacity of 5.25 million litres.³⁴ They also constructed a fuel pipeline with six pumping stations, which extended some 100 kilometres from the port of Al Jubail. Theatre-wide, an enormous fuel resupply operation was undertaken, which included installation of 420 kilometres of petroleum pipeline; and facilities were built to provide 38 million gallons (in excess of 170 million litres) of storage capacity.³⁵

Because of the speed of the ground advance, some units in western Iraq ran low on fuel and had to rely on air-dropped resupply as they outran their organic resupply vehicles. Of the many problems facing logisticians, the lack of rail transport from ports, thus necessitating greater use of trucks than expected, was probably the worst.

Requirements for different fuel types posed a problem and undoubtedly will act as a catalyst to develop a "single fuel concept."³⁶ More extensive prepositioning of stores, commonality

of computer systems, and greater control over spares emerged as important observations for the future. Additionally, the need for more strategic and tactical lift has prompted several studies into mobility requirements.

It is all very well to delay procurement decisions in peacetime and maintain equipment in a procurement pipeline, but some system is needed to allocate priorities to accelerate development and introduction into service of the most critical, once war breaks out. Furthermore, time to train crews in the use of new systems is also needed. That is, using a procurement pipeline in peacetime to save costs, carries with it attendant requirements in wartime—accelerated development of systems and training on those systems.

Procurement pipeline problems aside, the US procurement system witnessed improved acquisition times and the introduction of simplified procedures. The USAF process, from initial request to funding, normally required 12 months in peacetime; yet, during the Gulf crisis, it sometimes took as little as two weeks. Delivery times were also shortened, such as those for the hardened shelter penetrating bomb, GBU-28/B. The time taken from conceptual stage to the first bomb on target was less than six weeks.

In terms of simplified procedures, local purchase items had a threshold of \$25,000 which, during the crisis, was lifted to \$100,000. Additionally, standard contracting procedures were developed to further simplify the process.

Concluding Comment

In assessing the performance of logistics in the Gulf, the large quantities of food, water, fuel, and other materials and equipment provided by Saudi Arabia must be taken into account. Host-nation support for out-of-area operations is fundamental to success. Over 1,000 US defence contractors provided in-theatre support. Even with reliability and maintainability of modern systems, the need for contractor support in war zones is a lesson of importance. Contractor support will loom as an even larger issue in future wars as many military functions become "civilianised." Even with host-nation, civilian, and lateral support, large numbers of military personnel were required for logistics duties. Perhaps the most important observation to emerge from the air war in the Gulf was that operational logistics is a fundamental element of campaigning in the air.

Notes

¹Readiness is the amount of combat air power available and how quickly it can be exercised. Sustainability is the length of time over which that planned level of combat air power may be maintained. Both definitions are contained in Air Power Studies Centre, *AAP 1000, Royal Australian Air Force Air Power Manual*, RAAF Base Fairbairn, Canberra, 1990, p.102.

²A description of logistics doctrine is contained in Air Power Studies Centre, *AAP 1000, Royal Australian Air Force Air Power Manual*, RAAF Base Fairbairn, Canberra, 1990, pp. 207-213.

³*Conduct of the Persian Gulf Conflict: An Interim Report to Congress*, Washington DC, 1991, p. 7-2.

⁴*Ibid.*, p. 7-1.

⁵These figures have been compiled from two sources—USAF White Paper, *Air Force Performance in Operation Desert Storm*, April 1991, p. 13, and Secretary of the Air Force, United States Air Force Fact Sheet, Special Edition entitled *Airpower in Operation Desert Storm*, Office of Public Affairs, Washington DC, March 1991, p. 2.

⁶USAF White Paper, *Air Force Performance in Operation Desert Storm*, p. 13.

⁷Salomon, Lieutenant General Leon E., and Bankirer, Lieutenant Colonel Harold. "CASCOM Support for Desert Shield/Desert Storm," *Military Review*, April 1991, p. 5.

⁸*Ibid.*

⁹Sustainment roles are discussed in Air Power Studies Centre, *AAP 1000, Royal Australian Air Force Air Power Manual*, RAAF Base Fairbairn, Canberra, 1990, pp. 181-226, and encompass Command and Control; Communications; Intelligence; Ground Defence; Research, Development, Test and Evaluation; Logistics; Infrastructure; Administration; and Training and Education.

¹⁰Phillips, Rheta S. "Logistics Automation Support for Desert Storm," *Military Review*, April 1991, p. 9.

¹¹*Ibid.*, p. 11.

¹²USAF White Paper, *Air Force Performance in Operation Desert Storm*, p. 9.

¹³*Ibid.*

¹⁴Air Power Studies Centre, *AAP 1000, Royal Australian Air Force Air Power Manual*, pp. 214-220.

¹⁵Hayr, Air Marshal Sir Kenneth, KCB AFC CBE. "Logistics in the Gulf War," *RUSI Journal*, Autumn 1991, p. 18.

¹⁶*Ibid.*

¹⁷*Ibid.*, p. 19.

¹⁸Hill, Lieutenant Colonel Richard D. "Depot Operations Supporting Desert Shield," *Military Review*, April 1991, p. 18.

¹⁹*Ibid.*

²⁰Hayr, "Logistics in the Gulf War," p. 17.

²¹Jackson, Paul. "Tornado Storm," *RAF Yearbook Special - Air War in the Gulf*, Bristol UK, 1991, p. 62.

²²Braybrook, Roy. "Air Power on Trial," *Asia-Pacific Defence Reporter*, March 1991, p. 8.

²³Jackson, "Third Line - First Rate," *RAF Yearbook Special - Air War in the Gulf*, p. 77.

²⁴*Ibid.*, p. 76.

²⁵*Ibid.*, p. 77.

²⁶Mission capability is based on the criterion that at least one of the aircraft's primary functions can be performed.

²⁷Nash, Colleen A. "Desert Storm Logistics," *Air Force Magazine*, May 1991, p. 16.

²⁸*Ibid.*, p. 17.

²⁹*Ibid.* Figures for war were based on operations during the period 17 January to 22 February 1991, while peacetime figures were from October 1989 to July 1990.

³⁰Reed, John. "Deployments Out-of-Area: Did 'Desert Storm' Change the Rules?" *Defence*, April 1991, p. 19.

³¹Sweetman, Bill. "Catching Up With Doctrine," *Jane's Defence Weekly*, 29 June 1991, p. 1175.

³²Reed, "Deployments Out-of-Area," p. 19.

³³Blackwell, James; Mazarr, Michael J.; and Snider, Don M. *The Gulf War: Military Lessons Learned*, The Center for Strategic & International Studies, Washington DC, July 1991, p. 7.

³⁴Hayr, "Logistics in the Gulf War," p. 18.

³⁵*Jane's Defence Weekly*, 11 May 1991, p. 787.

³⁶*Ibid.*

Wing Commander Waters is presently assigned to the Directorate of Logistics Development and Planning, Department of Defence (AF), Canberra, Australia. He was assigned to the RAAF Air Power Studies Centre when he wrote this paper.





CAREER AND PERSONNEL INFORMATION

Civilian Career Management

Logistics Civilian Career Enhancement Program (LCCEP) and Acquisition Logistics

Acquisition logistics is one of 12 career fields within the Air Force's Acquisition Professional Development Program (APDP). Six civilian career programs are responsible for one or more of these 12 career fields:

Career Field	Career Program
Acquisition logistics	Logistics
Auditing	Comptroller
Business, cost estimating & financial management	Comptroller
Communications & computer systems	Comm-Computer Systems
Contracting (includes construction)	Contracting & Manufacturing
Industrial property management	Contracting & Manufacturing
Manufacturing & production	Contracting & Manufacturing/Scientist & Engineer
Program management	Program Management
Purchasing (includes the procurement assistant)	Contracting & Manufacturing
Quality assurance	Contracting & Manufacturing/Scientist & Engineer
Systems planning, research, development & engineering	Scientist & Engineer
Test & evaluation engineering	Scientist & Engineer

Although many people believe that acquisition logistics and acquisition program management are one and the same, they are actually two distinct career fields managed separately. The LCCEP is responsible for management of the acquisition logistics career field. This management includes training, education, experience opportunities, and filling acquisition logistics positions. Training, education, and experience opportunities are listed in the annual training guide and can be requested via the individual's annual Career Enhancement Plan (CEP). Acquisition logistics positions, grades 12-15, will be filled through promotion/reassignment rosters provided by the LCCEP.

Acquisition logistics includes a wide spectrum of functions not limited to duties within a program management office. These functions encompass the entire process of systematically identifying, developing, assessing, purchasing, and upgrading logistics requirements throughout the acquisition process. Acquisition logistics personnel include individuals, regardless of civil service series or military occupational specialty, who are involved in Integrated Logistics Support (ILS) activities as defined in DoDD 5000.1 and DoDI 5000.2. Also included are those who manage logistics activities associated with the procurement, integration, and fielding/sustainment of the support systems and/or environment (to include the ILS elements described in DoDI 5000.2) for weapon systems and/or equipment or system modifications.

Acquisition logistics positions are defined as those positions which require the incumbent to perform acquisition logistics functions, as described, at least 50% of the time. Positions with less than 50% acquisition logistics responsibilities, though not designated "acquisition positions," are still an important part of the APDP. Any position involving acquisition logistics related work provides experience which is creditable for acquisition certification and promotion or reassignment selections. Acquisition logistics positions will be identified as requiring Level I, II, or III certification. The level of certification is commensurate with the acquisition duties performed. Certification requirements for acquisition logistics contain some mandatory (M) and some desired (D) components:

LEVEL I

- Education:* (D) Baccalaureate or advanced degree in a technical, scientific, or managerial field.
- Training:* (M) One basic systems acquisition course.
(M) One Integrated Logistics Support (ILS) course.
(D) One Logistics Support Analysis (LSA) course.
- Experience:* (M) One year of acquisition logistics experience.

LEVEL II

- Education:* (D) Baccalaureate or advanced degree in a technical, scientific, or managerial field.
- Training:* (M) Meet the Level I requirements.
(M) One ILS management course.
(M) One LSA course.
(D) Basic courses in systems engineering, reliability and maintainability, configuration management, provisioning, and contracting.
- Experience:* (M) Two years in the logistics support of systems or in systems acquisition while assigned to a program management office, headquarters activity, or staff organization which provides support to an acquisition activity. At least one of these two years of experience must be in acquisition logistics while assigned to a program management office or an acquisition management activity.
(M) Two years of general experience in logistics support or in acquisition logistics.

LEVEL III

- Education:* (D) Baccalaureate or advanced degree in technical, scientific, or managerial field.
(D) At least 24 semester credit hours from an accredited institution of higher education from among the disciplines of accounting, business finance, law, contracts, purchasing, industrial management, economics, marketing, quantitative methods, and organization and management; or at least 24 semester credit hours from an accredited institution of higher education in the person's career field and 12 semester credit hours from the disciplines previously listed.

Keeping Up With Changes in Logistics Plans

- Training:** (M) Meet the Level II requirements.
(M) One intermediate course in systems acquisition management or a basic course in each of the following: reliability and maintainability, configuration management, provisioning, and contracting.
- Experience:** (M) Four years in the logistics support of systems or in systems acquisition while assigned to a program management office, headquarters activity, or staff organization which provides support to an acquisition activity. At least two of these four years of experience must be in acquisition logistics while assigned to a program management office or an acquisition management activity.
(M) Four years of general experience in logistics support or in acquisition logistics.

NOTE: Military and civilians must meet the same set of requirements for certification. For certification requirements in career fields other than acquisition logistics, please contact the respective career program.

Critical acquisition positions are defined as acquisition positions classified for fill by civilian employees in grades 14 and above or military 0-5 and above. As of 1 October 1993, all critical positions shall only be filled by Acquisition Corps members. The Defense Acquisition Workforce Improvement Act (DAWIA) and the Under Secretary of Defense for Acquisition (USD/A) have established minimum criteria that must be met to be considered for Acquisition Corps membership:

- Grade:** GS/GM-13/0-4 and above.
- Education:** Must have a baccalaureate degree and have completed at least 24 semester credit hours from among the disciplines of accounting, business finance, law, contracts, purchasing, industrial management, economics, marketing, quantitative methods, and organization and management.
- Training:** Must complete all mandatory training required for his or her acquisition career field through Level II.
- Experience:** Must have four years of experience in an acquisition position in the DOD or in a comparable position in another government branch or agency.

NOTE: The Acquisition Professional Development Council (APDC), the governing body of APDP for the Air Force, is currently developing the specific Air Force requirements for Acquisition Corps membership. The DAWIA and USD/A minimum requirements, as well as other Air Force unique requirements, will be included in the APDC's guidance when issued.

How can you become eligible for the acquisition logistics career field? Registration in the LCCEP automatically makes you eligible for training, education, experience, and promotion opportunities in the acquisition logistics career field. However, each individual is responsible for preparing and submitting his/her own certification package to the base civilian personnel office and acquisition logistics functional manager for review and forwarding. Acquisition logistics certification and the Acquisition Corps are a perfect complement to the LCCEP's goal of developing professional logisticians. Watch for additional news in future issues of the *Air Force Journal of Logistics* regarding the LCCEP and acquisition logistics.

(Lt General Trevor A. Hammond, USAF DCS/Logistics)

New Personnel

We have had a few changes at the Air Force Military Personnel Center (AFMPC) lately. PALACE LOG (DPMRSL) is now the Logistics and Acquisition Branch (DPMRSA), and Logistics Plans assignments are included as part of the Supply, Transportation, and Logistics Plans team (DPMRSA4). Our phone numbers remain the same; but, when you call, odds are the phone will be answered by Major Dave Smith. Major Smith is now responsible for field grade billets and joint duty assignments. He replaced Major Sue Eaves who left in July for her new assignment at HQ USAF/LGXX. Captain Ken Smith arrived in May 1992 as the new company grade resource manager. He comes from the Logistics Plans schoolhouse at Lowry AFB, Colorado. His background includes staff work with Headquarters Air Training Command (HQ ATC); retail experience at Keesler AFB, Mississippi; and aircraft maintenance at Hurlburt Field, Florida.

Job Opportunities

Results of the June 1992 Major/Captain Selective Early Retirement Board (SERB) and the July 1992 Reduction in Force (RIF) Board will significantly impact assignments. Look for more professional opportunities at a variety of locations. The three-year time-on-station rule still applies for CONUS-to-CONUS moves and two years for CONUS-to-overseas assignments. If you are interested in seeking a new job, and you are eligible to move, it is a good idea to scan the electronic bulletin board (EBB) at least every two weeks. Take down the tracking number, job title, and location, and then give your Logistics Plans assignment officer a call at DSN 487-5788/5789. We will do our best to assist you in getting the job most beneficial to you and the USAF.

Foreign Language Proficiency

Have you ever considered a choice job, but failed to qualify because it requires foreign language proficiency? You can cure that problem by taking the defense language aptitude battery. It is like no test you have ever taken; and, based on the results, you can qualify for a variety of language classes offered at the Defense Language Institute, Monterey, California. See your CBPO customer service representative for details.

Training

The schoolhouse personnel at Lowry AFB are working hard to put new officer and NCO entry level courses on-line by January 1993. These courses will address Air Force organizational changes and the latest policy/procedural guidance, and be scenario-driven. The unique training concept complements outstanding instructors who provide our students with some of the very best training offered in the Air Force. Unfortunately, we are backed up approximately six to eight months in getting people into school; and it may get worse as we prepare to move the courses to Lackland AFB, Texas, in Summer 1994. We and the schoolhouse personnel will do our best to meet the demand for training, but be prepared for some delays.

(Capt Ken Smith, HQ AFMPC/DPMRSA4, DSN 487-5788)

Preserving the History of Air Power Logistics in the Southeast: The First Decade of the Museum of Aviation at Robins AFB, Georgia

*Dr William Head
Dr Richard W. Iobst*

Most scholars and citizens of the United States are very familiar with the great national aerospace museums, such as the Air and Space Museum in Washington, and the Air Force Museum near Dayton, Ohio. However, in the past two or three decades, many smaller aerospace and aeronautical museums have opened for the public display of historic aircraft and aerospace artifacts. Certainly, one of the largest and most successful of these has been the Museum of Aviation at Robins Air Force Base, Georgia.

Located in the heart of Middle Georgia, the Museum of Aviation has, over the past decade, come to play an ever-increasing role in preserving the historical development of flight in the region and at Robins. Originally known as the Southeastern Museum of Aviation, the Museum of Aviation was created as part of the Air Force Logistics Command* (AFLC) Heritage Program. General James P. Mullins, then commander of AFLC, initiated this program in September 1981 to "preserve and display the heritage, traditions and contributions of the logistics arm of the United States Air Force for base personnel and the public."¹ At the local level the initial development of the museum occurred under the watchful eye of Major General John R. Paulk, then commander of the Warner Robins Air Logistics Center (WR-ALC). Locally, the Heritage Program encompassed three projects:

(1) A book, *A Pictorial History of Robins AFB, Georgia*, published by University Press of the South, Macon, Georgia, in 1982.

(2) A memorialization program to name base facilities for distinguished former members of the Air Force.

(3) The initiation of the museum.²

The Origins of the Museum at Robins AFB

Interestingly, the concept of a museum at Robins actually predated the AFLC Heritage Program. Although a museum had been occasionally discussed since the early 1950s, it was only in early 1978 that Guy Orlando Stone, a World War I aviator living in Glenwood, Georgia, told Lieutenant Colonel Steve Knowles (USAF-Retired) of the Directorate of Materiel Management and a leader in the local chapter of the Order of Daedalians, and Billy R. Beck of the Warner Robins Air Logistics Center Office of Public Affairs, that he possessed a large collection of aviation memorabilia. Stone generously offered to donate the collection to WR-ALC if a reasonable prospect existed for the construction of a museum at Robins. In mid-1980, officials at WR-ALC submitted a request to Air Force Headquarters in Washington in accordance with Air Force Regulation 210-4, *Air Force Museum Programs*, for permission to underwrite a local museum. Upon approval by the Air Force Office of Public Affairs, Dr Richard W. Iobst, the first museum curator, accepted what became known as the Stone Collection on 5 December 1980. In

September 1981, Dr Iobst greatly increased the museum's holdings with his acquisition of the General Frank O'Driscoll "Monk" Hunter Collection. Housing these acquisitions became the basis for opening museum offices in early 1982 in Building 1686 on Duke Street in the old section of Robins. In December 1982, these offices, along with the Office of History (WR-ALC/HO)—formerly located in Building 220 at Robins AFB—moved to larger quarters in Building 660 where they were collocated for several months. About 20 months later, again for reasons of additional space, the museum offices moved once more to Building 264.³

On 11 February 1981, local civic leaders, with the assistance of base officials, incorporated the Southeastern Museum of Aviation Foundation under the laws of the State of Georgia to guide the development of the museum. Its charter designated the foundation as a nonprofit private charitable organization which existed:

(1) To preserve the heritage and tradition of military and civilian aviation in the Southeastern United States.

(2) To foster the study of aerospace history in the Southeastern United States.

(3) To stimulate esprit de corps by telling the military and civilian aviation story through displays of historical significance.

(4) To support the Air Force recruiting program and enlistment by informing the public and youth of the Southeastern United States through educational exhibits which present the history of the Air Force.

(5) To foster the economic growth of Middle Georgia, the State of Georgia, and the Southeastern United States.⁴

The Museum Board of Directors included 27 members and 9 standing committees. The first Board Chairman was Elisha Gordon "E. G." Sherrill, Jr., who served from December 1980 until his death in May 1982.⁵ The charter also provided for a Board of Governors to be composed of people who had earned special recognition for their interest, devotion, and service to the foundation and museum. The Board of Governors function was to counsel and advise the Board of Directors on significant matters pertaining to the development and operation of the museum and its foundation.⁶

On 18 December 1981, museum planners submitted a detailed ten-year museum development plan to WR-ALC and AFLC Public Affairs officials. The first phase called for the construction of a series of prefabricated buildings and an outdoor exhibit of historical aircraft on 43 acres at Robins adjacent to Georgia Highway 247 and south of Gate 14. Phase II proposed the creation of a permanent museum building of 34,850 square feet, while the last phase included the erection of four hangars and 22,000 square yards of paved apron space. For the time being, AFLC Public Affairs could only approve Phase I due to monetary considerations. Compounding the problem was the fact that Dr Iobst had to leave his position as curator to assume new duties as Chief of the WR-ALC Office of History in

*Now Air Force Materiel Command

December 1981, when its former Chief, Richard E. Maltais, died.⁷

Despite these setbacks, General Paulk moved to provide additional support by placing the development of the museum under the direction of the WR-ALC Directorate of Plans and Programs. Thus the museum continued to grow under the guidance of this new unit. In addition, the museum received the support of countless local volunteers, who raised money and acquired artifacts and historic aircraft at an astonishing rate.

During the summer of 1982, AFLC officials sent the ten-year museum plan through channels to the Office of the Secretary of the Air Force. In July 1982, the Secretary of the Air Force finally approved a revised version of the original ten-year three-phase plan, which provided for a \$9.5 million program designed to construct the museum's physical plant using private funds. As a result, General Paulk placed the implementation of this project under the aegis of WR-ALC Plans and Program's Logistics Research and Systems Division.⁸

The following year saw the beginning of a major drive to raise more funds and collect artifacts prior to the construction of the first phase. This effort was described by museum planners as:

the most ambitious, long range effort under the Robins AFB Heritage Program, and . . . [one that was] expected to play an important role in the cultural and economic growth of Middle Georgia.

It began to take shape in March 1983, with the arrival of the museum's first airplane, a Grumman HU-16B "Albatross" amphibian aircraft.⁹ However, the first plane to be accepted into the museum collection was a McDonnell F-101F "Voodoo" fighter flown by Major General Richard F. Gillis (WR-ALC Commander from May 1988 until July 1992) when he was a young lieutenant.¹⁰

These acquisitions were followed during 1983 by the addition of 27 airplanes and helicopters as well as 5 missiles. In addition, plans called for the grand opening of the Phase I project scheduled for September 1984. At the end of 1984, the museum acquisitions team, headed by project officer Herbert E. Eschen, was making plans for the arrival of 15 more aircraft during the next year.¹¹

Throughout this early period, the project had the unswerving support of Major General Cornelius Nugteren, WR-ALC Commander from September 1982 to April 1988. His strong interest and encouragement were demonstrated by visits to the site, recognition of volunteer efforts, donations of personal artifacts, and his personal participation in and encouragement of volunteer workdays which included painting, planting trees and shrubs, and removal of trash and tree limbs. His constant interest and personal participation in volunteer efforts provided much of the impetus needed to propel the museum program along.¹²

Donations to the museum foundation provided the major source of funding for upkeep during these early years. During 1984, preparations for opening the Phase I facilities exhausted most of the museum's funds, while the remaining monies were used to complete exhibits and provide for lighting, painting, and landscaping. These donations totaled \$45,000 in 1983 and \$135,000 in 1984. Then Georgia Governor, Joe Frank Harris, provided the museum with \$10,000 from the state contingency fund. By the end of 1984, the artifacts valued at \$2 million, many coming from local citizens, were prepared for display in the 12,000-square-foot Phase I facility.¹³

As it became increasingly apparent that a continuing source of skilled labor to rehabilitate historic artifacts and aircraft was needed, the museum planners sought to fill this requirement in the most cost-effective way possible through the creation of the

"living museum" program. Local Vo-Tech students from such places as Middle Georgia Institute of Technology were recruited to provide sheet metal and other skilled repairs to museum aircraft. This proved to be doubly beneficial since the Vo-Tech students received important training, while historic aircraft were preserved for the Air Force. In addition, the museum management was able to acquire the services of Air Force units who also needed aircraft maintenance training. For example, with the encouragement of AFLC, recovering and repairing historic aircraft provided excellent crash battle damage training for personnel in the 2955th Combat Logistics Support Squadron. This was particularly true since recovering, moving, and repairing museum aircraft presented challenging situations which simulated crash battle damage conditions. As a result, the training exercises proved to be an unqualified success.¹⁴

By 31 October 1984, carpet had been installed and initial painting of interior walls of the Phase I "Butler" buildings, donated by the 14th Air Force, Dobbins AFB, Georgia, had been completed by a volunteer force from the Personnel Office at Robins. In the meantime, other ALC volunteers from various other organizations and directorates had completed final preparations for the official opening of the museum. With the building taking shape, coverage by base, local, and state media increased; and community interest reached an all-time high. Indeed, the opening ceremonies would mark the end of the beginning.¹⁵

1985: The Beginning of Phase I

On 9 November 1984, after long years of planning, the Robins AFB Museum of Aviation officially opened. Those attending the opening ceremonies included representatives from the office of Governor Harris, General Paulk (USAF-Retired), and General Nugteren.¹⁶

From November 1984 to May 1985, while the project continued to grow, it operated on a part-time schedule. In May, the staff set full-time hours from 10 a.m. to 5 p.m. daily except Mondays, Thanksgiving, Christmas, and New Year's. During 1985, over 60,000 people visited the museum. They came to see the ever-expanding collection of aircraft and the 12,000 square feet of interior exhibits featuring rare and unique aviation artifacts. The museum staff provided daily tours for schools, ROTC units, community groups, senior citizens, and distinguished visitors. In March 1985, one of the most interested visitors and certainly the oldest, Mae Poole McLain of Macon, celebrated her 102nd birthday by visiting the museum and donating \$250.¹⁷

The most important jobs of the museum staff were the acquisition of artifacts and planes as well as fund raising. Contributions for 1985 totaled \$166,657. Some of the more noteworthy donations included \$2,500 from the Dixie Crows Chapter of the National Association of the Old Crows (Electronics Warfare Professionals), President Alan Becker presenting; \$10,000 from Trust Company Bank of Georgia, President J. Alan Neal presenting; \$25,000 over five years from the Warner Robins Chamber of Commerce; \$15,000 from the Middle Georgia Military Ball; \$20,000 from the Air Force Association golf tournament and auction; and the largest donation at that time, \$25,000 from Digital Equipment Corporation. By the end of 1985, the museum had raised over \$345,000 in its brief history.¹⁸

Aircraft added to the collection included the Lockheed C-140A "Jetstar" used by Vice-President and later President Lyndon B. Johnson, a rare Douglas C-124C "Globemaster," a Fairchild C-119C "Flying Boxcar," and a North American F-100

“Super Sabre Jet.” In addition, museum workers completed several aircraft displays, such as a Boeing B-52D “Stratofortress” number 55-085 (first flown by the father of the last pilot) and a Fairchild C-123K “Provider.”¹⁹

The museum also received numerous nonaircraft artifacts including a 1943 Women’s Army Corps (WAC) uniform from Dottie Cretors, a 1943 vintage Warner Robins City fire truck from the Warner Robins Fire Department, and several German World War II military artifacts from Terry Kimberly, an Air Logistics Center (ALC) employee and World War II pilot and POW, and Birch McVey of Cochran, Georgia.²⁰

In July, the museum board decided to conduct a feasibility study for Phase II, contracting with Charles H. Bentz Associates of Atlantic City, New Jersey. In anticipation of the need for capital funds to construct the second phase, the board appointed a fund-raising committee with Senator Sam Nunn (Democrat-GA) acting as honorary chairman. At the end of 1985, the museum staff expected the study to be completed in late January 1986. At that time, plans called for a final board decision regarding the capital campaign.²¹

1986: Preparations for the Future

During 1986, the Museum of Aviation continued its rapid growth while at the same time planning for a major expansion. In the summer of 1986, visitation increased to over 2,000 people weekly. Museum volunteers continued to provide daily tours of the expanding facilities for school and civic groups from all over the Middle Georgia area.²²

The museum also proceeded with its tradition of using local vocational and technical school students and volunteers from Air Force units to accomplish much of the needed work on the facilities and artifacts. These individuals continued receiving experience in sheet metal repair and other aerospace technical maintenance areas while helping to restore aircraft. Meantime, local volunteer groups from the ALC work force helped refurbish buildings, build concrete picnic tables and benches, and perform beautification work.²³

In 1986, aircraft added to the museum collection included a Douglas A-26C, Korean era medium bomber; a DeHavilland C-7A “Caribou,” Vietnam era cargo plane; and a Ryan PT-22 trainer of the World War II period. Interior exhibits were expanded with a major collection of memorabilia on the Vietnam War, a display on the Seventh Logistics Support Squadron, and a special exhibit featuring celebrated Brigadier General Robert Lee Scott (USAF-Retired), author of *God is My Co-Pilot*. The Scott exhibit contained a first edition of his well-published book; photographs showing the making of the Warner Brothers movie and its 1945 world premiere in Macon, Georgia; Scott’s West Point cadet dress uniform; and an original drawing of a National Recovery Administration (NRA) eagle signed by Walt Disney. Part of the exhibit featured Scott’s colorful career as a Curtiss P-40 “Warhawk” pilot attached to General Claire Lee Chennault’s Flying Tigers in China, and later as a World War II ace and Commander of the 23rd Fighter Group, formed when the Flying Tigers were disbanded when the US entered the war.²⁴

In addition to growing local publicity, the museum received national and international recognition when featured as one of the top 70 museums among 700 worldwide aviation museums listed by the publication *Great Aircraft Collections of the World*. The museum was also featured in *Fly Past Magazine*, published in Great Britain.²⁵

As a result of the museum’s initial success, and public support, the capital fund-raising campaign enjoyed fruitful

progress. In 1986 alone, Charles H. Bentz Associates, the funds counsel, raised over \$500,000 of the \$3 million “Heritage of Eagles” goal.²⁶

1987 and 1988: The Challenges to Begin Phase II

Museum personnel levels remained constant throughout 1987; and, with continuing base and volunteer support, the museum continued its operations at previous levels and soon began planning for the commencement of the Phase II expansion.²⁷

During 1988, the Museum of Aviation at Robins, as it was now known, continued its drive for capital funds, bringing the museum closer to the groundbreaking for its Phase II facility. According to Peggy Young, then Program Development Manager for the museum, the Board of Directors was working with “renewed vigor and enthusiasm” to break ground for the new building. By the end of the year, the ultimate goal was \$5 million, \$3 million going for the construction of the 60,000-square-foot facility, with the remaining monies to be spent on interior exhibits, centers of historic significance, and contemporary interests.²⁸

While the capital fund-raising drive was underway, the museum also launched a membership drive to raise funds so it could continue to operate. The theme for this campaign, called the “Society of Eagles,” was “Join us . . . and soar with eagles.” The society dedicated itself to preserving aviation history and the traditions of the Air Force, seeking to accomplish its goals through the museum. Membership in the society was open to anyone committed to these goals. The bronze, silver, and golden eagle members supported the society and its programs with donations and annual membership dues. In turn they received society benefits and privileges. For example, bronze eagle members alone received a Society of Eagles membership certificate, society newsletter, a membership card, a poster, special travel opportunities, museum of aviation gift shop discounts, local retail discounts, and invitations to previews and gala openings. Bronze charter memberships were \$10 for students and \$25 for adults, while silver eagles ran \$100 for individuals and \$150 for clubs and businesses. Golden eagles cost \$500 for individuals and corporations, while sustaining gold memberships were available for \$1,000.²⁹

The Museum of Aviation’s internationally recognized collection of aircraft increased during the year, adding a McDonnell-Douglas F-4 “Phantom II,” a Beechcraft C-45 “Expedito,” and a Lockheed EC-121 “Constellation.” The final big addition to the museum in 1988 was the “Cochran Field Flight Control Tower.” Built in the early 1940s to support Air Corps flying training during World War II, the tower was donated to the museum by the City of Macon.³⁰

1989: The Light at the End of the Tunnel

By 1989, the Museum of Aviation at Robins had become one of the top three tourist attractions in Georgia. It continued to be open to the general public without charge. With its display of aircraft, missiles, static artifacts, and films on aviation shown in the Theater of Aviation, the museum remained popular with children and adults alike.³¹ It also continued to provide educational opportunities for local schools and civic groups. But no one told the kids it was good for them. As far as they knew a field trip to the museum was a day filled with enjoyable things to do and neat things to see.

During fiscal year 1989, museum leaders added a number of impressive displays and exhibits. On 4 October 1988, Colonel Edgar C. Knowling, Commander of the 5th. Combat Communications Group, formally presented the museum with a

jeep, designated as an MRC-107 communications central. It was equipped with various communications devices which served as forward air controllers to coordinate tactical aircraft activities in support of frontline commanders. From an historical standpoint, the jeep had been used to support American forces in World War II and later as a staff car, supply truck, ambulance, and amphibious light troop carrier. It had also been used in the 1979 Iran hostage rescue attempt.³²

On 19 April 1989, in a brief ceremony at the State Capitol in Atlanta, Governor Harris signed into law House Bill 110 which created the Georgia Aviation Hall of Fame and made the museum its home. The hall was created to honor aviation leaders who made outstanding and lasting contributions to aviation history in Georgia or as Georgians. A banquet honoring the first seven inductees was held at the Robins Officers' Club on 26 August 1989. The inductees were General Robert L. Scott; Benjamin T. Epps, Sr., of Athens, recipient of the first Georgia Aviation Pioneer Award; Corporal Eugene Jacques Bullard of Columbus, the first black military aviator in World War I; Lieutenant Guy O. Stone, the World War I pilot whose collection began the Museum; Hazel Jane Raines of Waynesboro, the first woman in Georgia to receive a commercial license; retired Air Force Major General and World War I air ace and World War II Air Commander of the VIII Fighter Command, Frank O'Driscoll "Monk" Hunter of Savannah; and retired Navy Commander Hamilton McWhorter III, the first naval carrier ace in World War II, who later became a double ace.³³

On 7 June 1989, the last operational "C" model U-2 spy plane was donated to the museum. The aircraft, serial number 56-6682, was the eighth production model built in 1955 by Lockheed Aeronautical Systems Company of Burbank, California (later Marietta, Georgia). Known as the "Dragon Lady," the "Black Lady of Spy Planes," or simply Article 349 of the Central Intelligence Agency (CIA), it was designed for surveillance missions above 55,000 feet. It logged a total of 8,680 hours flight time, 5,300 hours of which were for the National Aeronautics and Space Administration (NASA). Francis Gary Powers flew this aircraft before he was shot down in another U-2 over the Soviet Union on 1 May 1960. The 34-year-old U-2C aircraft ended its career on a "high" note on 17-18 April 1989, when Lockheed pilots Jerry Hoyt and Ron Williams used it to set 16 world records in its class for time-to-climb and altitude at the Dryden Flight Research Facility, Edwards AFB, California.³⁴

Three weeks after the arrival of the U-2, the museum also acquired a Stearman PT-13 trainer of the pre-World War II period. The aircraft came to the Robins museum on 29 June from the Air Force museum at Wright-Patterson AFB, Ohio. Despite extensive damage incurred during shipment, the PT-13 was repaired and ready for display by 5 July 1989. This effort was only one more demonstration of the talent of those working for the museum at Robins.³⁵

By the end of 1989, the Heritage of Eagles Campaign was approaching the \$3 million total necessary to start construction on the museum's \$5 million Phase II facilities. Museum officials had hoped to break ground for the new three-level building (60,000 square feet), shaped like a giant Air Force wing insignia, by the end of the year; but funding problems continued to delay the project. Plans for the new facility called for it to house a new theater and state-of-the-art displays depicting the history of aviation and logistics at Robins and in Georgia.³⁶ Despite the disappointments of 1989, the dedicated persistence of dozens of personnel at the museum would soon pay off as the 1990s dawned.

The 1990s: The Museum Honors Robins AFB's 50th Anniversary

The year 1990 saw the creation of an official archives project and a student intern "for credit" program in conjunction with five Middle Georgia colleges and universities. These enterprises made the Museum of Aviation one of the most vigorous and effective educational outreach and volunteer institutions in the Southeast.³⁷

During this period, the museum also added several new aircraft including a Lockheed SR-71 "Blackbird," a British Aerospace MK53 Lightning fighter from British Aerospace Inc., and an East European copy of a Soviet MiG-17, bringing to 62 the total of aircraft, missiles, drones, and helicopters on display. Of equal significance was the donation to the museum of a large collection of memorabilia by the Hump Pilots Association—a 59,000-member, "last man" organization of World War II pilots and ground crewmen who flew supply routes over the Himalayan Mountains in the China-Burma-India Theater. This important contribution was accompanied in February 1991 by a generous donation from the Association totaling \$100,000.³⁸

Beginning in late 1989 and continuing into the 1990s, museum operations were transferred from the WR-ALC's Directorate of Plans and Programs to the 2853rd Air Base Group under the immediate supervision of Mr Paul Hibbitts, Base Executive Officer. By this time, the museum had grown significantly, due in large measure to the efforts of the foundation, museum volunteers, and an able staff of artists and exhibits designers, including Jim Balletto, Curator Darwin Edwards, Preservationist William Paul, and Director Peggy Young.

Today, with its gift shop and snack bar done in a 1940s motif, the museum continues to be a popular public attraction not only for local residents but also for those traveling to the area. By 1990, almost a million visitors had passed through the museum, including many veterans and their families, providing them with the chance to relive wartime experiences as they examined the planes they once flew or maintained.³⁹

By the end of 1990, pledges and contributions to the museum fund-raising drive for the construction of Phase II totaled \$3.6 million. This meant that the long-awaited groundbreaking for the Phase II facility could be scheduled. But first, the hard-working staff completed an interim Phase I addition and added to the ever-expanding pantheon of museum structures.⁴⁰

On 5 April 1991, General Gillis; Colonel Lawrence A. Stone, Commander of the Air Base Group; and 600 guests dedicated a new Phase I facility reclaimed from an old discarded 1950s temporary metal hangar. Dubbed "Hangar One" and renovated to look like a World War II flying field, the 28,000-square-foot facility was designed to house larger displays and smaller aircraft such as helicopters and trainer aircraft.⁴¹

A memorable occasion for the museum came on 7 June 1991, when General Gillis hosted 300 guests, including Georgia Governor Zell Miller, at the official groundbreaking for the construction of the long-awaited Phase II museum building.⁴² The ceremony was a joyous occasion, one dedicated to the memory of some of the founders of the museum like the late Guy O. Stone and E. G. Sherrill, as well as all the thousands of employees of Robins from the past 50 years.

During 1991-1992, construction proceeded on the Phase II building as scheduled. Finally, the proudest moment of all came on 3 July 1992 when the building was completed and Senator Nunn dedicated the new facility. Because of the dedication and hard work of so many people, the beautiful Museum of Aviation will continue as long as there is a Robins AFB and the US Air Force.



Senator Nunn at the Podium.

Notes

¹Report, WR-ALC/XR to HQ AFLC/CC, "Heritage Program Status Report," 25 Jan 85; Letter, General James P. Mullins, AFLC/CC to Major General John R. Paulk, WR-ALC/CC, "AFLC's Heritage Program," 23 Sep 81.

²Letter, General James P. Mullins, AFLC/CC to Major General John R. Paulk, WR-ALC/CC, "AFLC Heritage Program," 26 Sep 81. For detailed documents covering the early history of the museum, see Dr Richard W. Iobst, "Museum Documents," in 3 volumes, WR-ALC/HO, Robins AFB, Georgia.

³Report, by Colonel Terry P. Weyant, WR-ALC/XR, "Museum," 25 Feb 80; Letter, Brigadier General H.J. Dalton Jr., HQ AFLC/PA to Secretary of the Air Force/PA, "Proposal for the Robins Air Force Base Museum of Aviation of Georgia," 8 Jul 80. Hunter Army Air Field near Savannah is named for General "Monk" Hunter.

⁴Office of History, WR-ALC History, FY82, p. 28.

⁵Letter, Brigadier General Richard F. Abel, USAF/PA to Major General John R. Paulk, WR-ALC/CC, "Proposal for the Southeastern Museum of Aviation at Robins AFB, Georgia," 15 Jul 82.

⁶Ibid.

⁷Ibid.

⁸Ibid.

⁹"Friends Help Museum Get Off Ground," *Robins Rev-Up*, 2 Dec 83, pp. 17 and 21; "Robins AFB Museum Acquires Bombsight," *Robins Rev-Up*, 14 Oct 83, pp. 1 and 2; "Vassas Gives 'Find' to Aviation Museum," *Robins Rev-Up*, 20 Jan 84, p. 3.

¹⁰Head, William, and Wright, Isabel. *Keep 'Em Flying: Robins Air Force Base, Fifty Years of Service to the Nation* (Macon, Georgia: Williams Rowland Press, 1991), p. 54 [hereafter cited as *Keep 'Em Flying*].

¹¹Report, by Peggy B. Young, WR-ALC/XRS, "Robins AFB Acquisition of Aviation Historical Aircraft Collection," 25 Jan 85. The Museum's 1985 aircraft holdings included: McDonnell F-101F "Voodoo," Boeing B-29B "Superfortress," Boeing B-52D "Stratofortress," Vertol CH-21B "Workhorse," Douglas C-47A "Skytrain," Douglas C-54G "Skymaster," Fairchild C-123K "Provider," Lockheed F-80C "Shooting Star," North American F-86H "Sabre Jet," Northrop F-89J "Scorpion," Convair F-102 "Delta Dagger," Republic F-105 "Thunderchief," Sikorsky HH-34J "Choctaw," Grumman HU-16B "Albatross," Cessna L-19/01 "Bird Dog," Stearman PT-13/17 "Kaydet," Gyrodyne QH-50 "Dash," Martin RB-57A "Canberra," Lockheed RB-69A "Neptune," Republic RF-84F "Thunderstreak," North American T-6G "Texas," North American T-28C "Trojan," Convair T-29A "Flying Classroom," Lockheed T-33A "Shooting Star," Beechcraft T-34A "Mentor," Bell UH-13P "Sioux," Douglas WB-66D "Destroyer," Benson X-25A "Gyrocopter," DeHavilland C-7A "Caribou," Beechcraft C-45 "Expediter," Douglas C-118 "Liftmaster," Fairchild C-119C "Flying Boxcar," Lockheed C-121 "Constellation," Douglas C-124C "Globemaster," Lockheed C-140A "Jetstar," Republic F-84E "Thunderjet" (straight wing), Republic F-84E "Thunderstreak," North American F-100 "Super Sabre Jet," Bell H-1F "Huey," Sikorsky H-5 "Dragonfly," Sikorsky H-19 "Chickasaw," Cessna U-3 "Blue Canoe," Martin WB-57F "Canberra," Hughes AIM-4D missile, Boeing CIM-10A "Bomarc," Martin MGM-13A "Mace," Northrop SM-62 "Snark," and Martin TM-61A "Matador." Among those aircraft acquired since 1985 are the U-2 spy plane, a Russian MiG-17, British Aerospace Lightning MK53, B-26K, and SR-71 "Blackbird."

¹²Head and Wright, *Keep 'Em Flying*, p. 55.

¹³Briefing, by WR-ALC/XRS for WR-ALC/CV, CC, "Major Force Program 9 Funds, FY84-85 for Robins AFB Museum of Aviation," 26 Oct 84; Staff

Summary Sheet (SSS), by WR-ALC/XR, "Donations to RAFB Museum of Aviation," 18 Dec 84; SSS, by WR-ALC/XR, "Museum of Aviation Donations," 21 Dec 84; SSS, by WR-ALC/XR, "FMA Donation to RAFB Museum of Aviation," 2 Oct 84; SSS, by WR-ALC/XR, "Grumman Aircraft Donation to Museum of Aviation," 5 Oct 84; SSS, by WR-ALC/XR, "Donation to Robins AFB Museum of Aviation," 25 Oct 84.

¹⁴SSS, by WR-ALC/XR, "Requests to Organizations for Project Volunteers," Oct 84; Memo, Peggy Young, WR-ALC/XRS to Herbert E. Eschen, WR-ALC/XRS, "Museum Progress/Requirements," 8 Oct 84.

¹⁵"Aviation Museum reality; reaches end of beginning," *Robins Rev-Up*, 16 Nov 84, p. 1.

¹⁶Report, by WR-ALC/XRS, "Robins AFB Museum of Aviation Status," 19 Oct 84; Memo, WR-ALC/XRS to WR-ALC/CE, CV, CC, "Museum of Aviation Victory Celebration," 29 Nov 84; Article *Robins Rev-Up*, 9 Nov 84, pp. 1, 3, & 24.

¹⁷Letter, WR-ALC/XR to HQ AFLC/XRP, "Heritage Program Status Report," 25 Jan 85; Report, by WR-ALC/XRS, "Robins AFB Museum of Aviation," 30 Aug 85; Memo, WR-ALC/XRS to 2853 ABG/PA, "Interest Items for WR-ALC Officers' Call," Oct 84; "Museum's Visitor," *Robins Rev-Up*, 15 Mar 85, p. 15.

¹⁸Memo, WR-ALC/XRS to 2853 ABG/PA, WR-ALC/CE, CC, "Dixie Crows Donation to Museum," Aug 85; Memo, WR-ALC/XRS to WR-ALC/CE, CV, CC, "Donation to RAFB Museum of Aviation," Dec 84; Memo, WR-ALC/XRS to WR-ALC/CE, CV, CC, "Museum Activities," 1 Mar 85; "Digital Equipment Making a Commitment," *The Daily Sun* (Warner Robins), 4 Feb 85, p. A-3; "Gala Raises \$17,000 for RAFB Museum of Aviation," *The Daily Sun* (Warner Robins), 30 Sep 85, p. A-6.

¹⁹Memo, WR-ALC/XRS to WR-ALC/CE, CV, CC, "Museum Activities," 30 Nov 84; Memo, WR-ALC/XRS to WR-ALC/CE, CV, CC, "Museum Activities," 7 Dec 84; Memo, WR-ALC/XRS to WR-ALC/CE, CV, CC, "Museum Activities," 31 Dec 84; Memo, WR-ALC/XRS to WR-ALC/CE, CV, CC, "Museum Activities," 11 Jan 85; "Headed Home," *Robins Rev-Up*, 7 Sep 85, p. 8; *Macon Telegraph and News*, 14 Sep 85, p. 18.

²⁰"A Collectors Item," *Robins Rev-Up*, 16 Aug 85, p. 1; "German Uniform is Museum Piece," *The Daily Sun* (Warner Robins), 2 Sep 85, pp. A-1 and A-7.

²¹Report, by WR-ALC/XRS, "Robins AFB Museum of Aviation Proposed Board of Directors," 15 Feb 85; Memo, WR-ALC/XRS to WR-ALC/CE, CC, "Museum Activities," 17 Jul 85; Minutes, Robins AFB Museum of Aviation Foundation Board of Directors Meeting, 31 Jul 85; Minutes, Robins AFB Museum of Aviation Board of Directors Meeting, 23 Sep 85.

²²Letter, WR-ALC/XRS to WR-ALC, Office of History, "Request for Documentation," 14 Nov 86.

²³Ibid.

²⁴Ibid.

²⁵Ibid.

²⁶Ibid.

²⁷Letter, Det 6, 3025 MES/CC to WR-ALC/HO, "Request for Documentation," 23 Oct 87.

²⁸"Museum," *Robins Rev-Up*, 2 Oct 87, p. 1.

²⁹"Fund-Raising Drive For Air Museum Reaches Milestone," *Robins Rev-Up*, 11 Dec 87, p. 1.

³⁰"Museum," *Robins Rev-Up*, 2 Oct 87, p. 1; "New Museum Aircraft," *Robins Rev-Up*, 4 Dec 87, p. 1; "Museum," *Robins Rev-Up*, 28 Mar 88.

³¹WR-ALC RAFB Publication 190-8.

³²"5th CCG Donates Jeep to Museum of Aviation," *Robins Rev-Up*, 7 Oct 88, p. 1. The 5 CCG has changed its name on several occasions in recent years. However, it is still most commonly known as the Fifth Mob.

³³"New Law Establishes Aviation Hall of Fame," *Robins Rev-Up*, 21 Apr 89, p. 1. It should be noted that Bullard did not fly for the US Air Service in World War I due to the segregated nature of the US armed forces. Instead, this self-taught pilot enlisted in the French Air Service and became a leading French ace by 1916.

³⁴"Dragon Lady Makes Museum its Final Home," *Robins Rev-Up*, 9 Jun 89, p. 1.

³⁵"Museum Workers Prepare Pre-World War II Trainer for Display," *Robins Rev-Up*, 7 Jul 89, p. 1.

³⁶"Lockheed Donation Brings Museum Closer to Reaching Goal for Phase II," *Robins Rev-Up*, 9 Jun 89, p. 1.

³⁷Head and Wright, *Keep 'Em Flying*, p. 55.

³⁸Ibid., pp. 55-56.

³⁹Ibid., p. 57.

⁴⁰Ibid., pp. 54-55.

⁴¹Bailey, Joyce, "Museum Cuts Ribbon on Hangar One," *Robins Rev-Up*, 5 Apr 91, p. 3.

⁴²"The Next Step: Ground Breaking to Usher in New Phase of Construction at Museum," *Robins Rev-Up*, 7 Jun 91, pp. 1-2.

Doctors Head and Iobst are Historians in the Office of History, Warner Robins Air Logistics Center, Robins AFB, Georgia.



System Readiness Analysis for Joint STARS Aircraft

Richard A. Moynihan, Ph.D.
Audrey E. Taub

Introduction

The Joint Surveillance and Target Attack Radar System (Joint STARS) is a combined Army-Air Force program designed to provide wide-area surveillance for tactical battle management, including detecting, classifying, and tracking moving or stationary ground vehicles over a large battlefield. The prime component of Joint STARS is the E-8 (modified Boeing 707) aircraft platform which carries a multimode radar. The E-8 also contains an operational and control (O&C) subsystem to provide data processing and communication functions.

To take advantage of the unique capabilities Joint STARS provides, the two prototype aircraft were called into service during Operation Desert Storm in the Persian Gulf. Joint STARS played a significant role, "helping locate and target mobile Scud missile launchers, and telling U.S. ground troops that there was nothing between them and the Republican Guard." (5:1)

The basic Air Force scenario for Joint STARS calls for an E-8 squadron (consisting of from three to six aircraft) to be deployed to a forward operating location. A typical operational requirement is to then support one geographically-specified airborne "orbit" 24 hours a day for up to 30 days. The several E-8 aircraft successively rotate through their orbit-coverage sorties, with each aircraft, upon completion of an assignment, undergoing variable maintenance and logistics support activities in order to return to mission-ready status for its next assigned sortie.

The focus of the Joint STARS System Readiness Analysis (SRA) is to measure how well the basic reliability and maintainability (R&M) characteristics of the E-8 system, together with a specified logistics support structure, help sustain this basic operational requirement. In other words, given our basic mission: (1) What are the key factors which limit our ability to keep a functioning Joint STARS aircraft on-station? (2) What changes in these factors will provide the greatest increase to the attainable orbit coverage time?

The Joint STARS SRA effort responds to continuing emphasis within the Department of Defense and the Air Force to increase force effectiveness by fielding more reliable and supportable systems. In particular, the Air Force R&M 2000 Program has been instituted with a mandate to increase our combat capability by building combat readiness and greater self-sufficiency into the initial system design.

Methodology

The key tool used in the SRA was a PC-based discrete-event simulation which models the Joint STARS mission. Our goal was to develop a viable model which could address the sensitivities of the complex interaction of mission activities and support resources, but which could still yield results in a timely fashion. The SRA simulation model was constructed during the Full Scale Development (FSD) phase of the Joint STARS Program when system design, operation, and support decisions were rapidly being finalized.

Before we started building our own model, we conducted a thorough search of available military simulation models. Many of these were too large and cumbersome to be efficiently modified so as to address the Joint STARS mission. Other models measured the wrong figure-of-merit (sortie generation rate rather than orbit coverage) and did not include interdependencies among different aircraft. For example, these drawbacks apply to the Air Force Logistics Composite (LCOM) model which is often used to analyze support resource requirements.

To meet our needs, we built a PC-based simulation model written in a computer simulation language. This approach proved to be very effective. A basic model was constructed in about one month's time to assess gross effects, and numerous enhancements were gradually added thereafter to provide more detail and accuracy.

The Joint STARS SRA integrates the impact of numerous reliability, maintenance, and logistics support factors into a single overall measure of system operational effectiveness. It has been common practice on almost all military acquisitions to set forth various individual R&M, operational, and logistics standards which are intended to ensure system readiness and supportability. However, it is often not immediately obvious what impact meeting or exceeding a particular standard has on performing the basic operational requirement; e.g., in the Joint STARS case, of keeping a mission-capable aircraft on-station. As a result, it is usually hard to determine which standards are most important and whether beneficial trade-offs can be made among them.

In fact, on most programs, specification values, such as for mean-time-between-failure (MTBF) and mean-time-to-repair (MTTR), are determined more by a judgment of what the current technology can do, rather than by an assessment of what the user requires. As mentioned, current Air Force directives call for a reversal of this trend.

Thus the SRA simulation is based on a readiness parameter which measures the combined effectiveness of a deployed E-8 squadron, together with specified logistics support resources (numbers of spares, repair test equipment, and personnel), to accomplish its station-keeping mission. The parameter selected is denoted as the "Mission Effectiveness Percentage" (MEP) and is defined as *the percentage of required time that a mission capable Joint STARS aircraft is on-station during this deployment period*. As a bottom-line number, the MEP does reflect the user's basic operational requirement. Thus, for our analysis, "combined effectiveness" is the overall ability of the deployed system, consisting of the aircraft and all support resources, to maintain orbit coverage, as measured by the MEP parameter.

SRA Simulation Logic

Figure 1 illustrates the key activities which take place when a squadron of E-8 aircraft is deployed to a forward operating location to establish and maintain orbit coverage. This figure also outlines the basic logic of our computer simulation. At any point in time during the deployment period, the various Joint

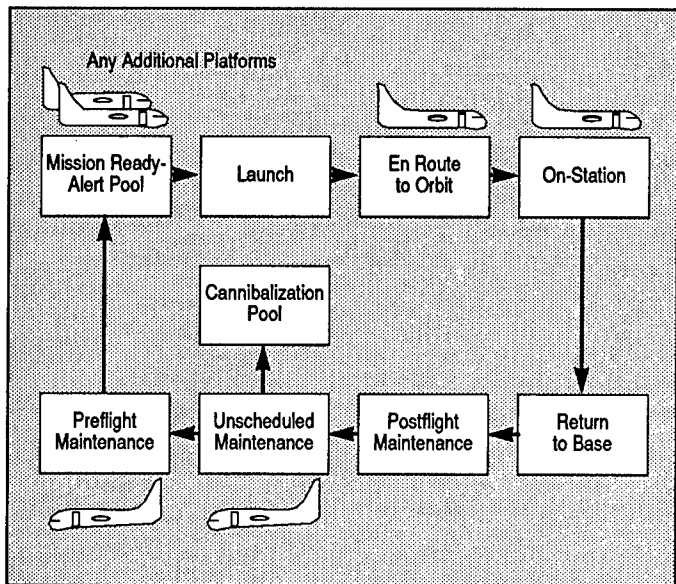

Figure 1. Joint STARS Mission Activities.

STARS platforms are engaged in a number of these separate activities. The most important activity from the point of view of mission performance is, of course, to keep an aircraft "on-station."

Within the simulation model, the activities shown in Figure 1 are represented by a combination of deterministic and stochastic events. For example, standard times are used for normal Launch, En-route, On-Station, Return, Postflight, and Preflight activities.

The stochastic elements of the simulation model are driven by statistical sampling of equipment failure and repair times. The database of the model contains a list of all equipment line replaceable units (LRUs) installed on an aircraft, including prime mission equipment (PME). We assume that LRUs fail independently of one another and that the time to failure for each LRU is a statistical random variable which follows an exponential distribution with a specified MTBF.

To initiate the sequence of in-flight activities for a given aircraft, the simulation program first performs a random sampling of failure times for all LRUs on the aircraft. The program records all LRU failures which occur within the standard 10-hour in-flight sortie (1-hour en route, 8-hour orbit, 1-hour return) and then processes this list to compute the time of the first mission critical failure (MCF).

The MCF time calculation depends on whether a particular failed LRU is labeled "mission critical." In addition, many LRU types are redundant so that multiple failures of that type are required to precipitate an MCF. For example, in the communications subsystem, only 13 out of the 16 "switch/filters" must remain working in flight to remain above the specified "acceptable performance level." To complicate matters a little bit further, some LRU types are designated as "in-flight repairable" (IFR), so their failure would cause an in-flight maintenance action—with some associated loss of mission coverage time—but would not cause an MCF with resulting air-abort.

An MCF will disrupt the normal flow of sortie activities shown in Figure 1. For example, if an MCF occurs during either the En-route or On-Station activities, the aircraft will notify the next plane in the Alert Pool, abort its mission, and proceed to the Return-to-Base block. Depending on when the MCF occurs during the sortie and how long the aircraft takes to return to base, the simulation program determines the set of LRU failures

occurring during that time period—and discards any other which occurred later on its list.

Considerable variation in aircraft maintenance turnaround time can then result as a function of this set of LRU failures. All failures which occurred in flight are addressed in the Unscheduled Maintenance activity. Some LRU failures may be repaired in parallel, depending on available manpower and support equipment. Other LRU failures (as in the landing gear or fuel system) necessitate certain safety precautions and thus must be handled sequentially. The actual repair times are statistically sampled from LRU-specific lognormal distributions.

Each repair also requires a specific combination of manpower skills and support equipment, and the unavailability of either will delay aircraft turnaround until the needed entities are free. Lack of a required LRU spare will ground an aircraft, which then enters the Cannibalization Pool to become a source of spares for subsequent aircraft maintenance actions.

(NOTE: Use of an exponential distribution to model times to failure and use of a lognormal distribution to model repair times have historically been judged the most appropriate probability laws to represent these phenomena in military system availability analyses. (See the survey in reference 6.) In addition, Air Force Logistics Command Regulation 57-18, *Management and Computation of War Reserve Materiel*, specifies these analyses be performed assuming independent failures with an exponential distribution. However, more recent analyses have challenged the standard use of the exponential failure distribution. (2) Accordingly, the SRA model is currently being modified to represent a more general Gamma family of failure time distributions.)

Factors Impacting MEP

In light of the mission activities described, we can identify specific events which decrement our mission effectiveness percentage (MEP). For example, some coverage will be lost whenever the aircraft on-station is forced to air-abort before being relieved. Even if there is a mission-ready aircraft on the ground, and even if the relief aircraft is en route, there will be a gap in on-station coverage of up to $1\frac{1}{4}$ hours (the launch-taxi time of 15 minutes plus the 1-hour en-route-to-orbit time). This gap degrades the MEP parameter.

A loss in MEP is also possible if a relief aircraft fails on launch. Depending on whether another aircraft is mission-ready and/or the aircraft currently on-station is able to extend its orbit coverage, there may again be a gap in on-station coverage.

There are also other events which cause gaps in on-station coverage. Examples of these are the time required to perform in-flight repairs while on-station and the nonavailability of a mission-ready relief aircraft when required (perhaps due to aircraft groundings from a lack of spare LRUs). Excessive maintenance turnaround times will also contribute to the nonavailability of relief aircraft.

The key point of these examples is that there are many activities and factors which contribute to the success (or lack of success) in keeping a mission capable aircraft on-station.

While the SRA includes the effects of numerous logistics factors, we did not attempt to address the impact of weather and possible enemy hostile action. These latter two factors could certainly impact mission effectiveness, but we felt that they were not predictable enough to be accurately modeled within the scope of our effort. The possibility of combat damage on a particular mission could, for example, dictate the need to deploy

one or two additional aircraft above and beyond what our analysis would suggest.

Simulation Language Features

The discussion of the key mission activities shown in Figure 1 gives an overview of the logic of the SRA simulation program, but it does not fully illustrate the great utility of the special features of a computer simulation language—GPSS in our case. (4,7) Other simulation languages, such as SLAM II or SIMSCRIPT, provide similar capabilities.

In GPSS, there are entities called transactions which move simultaneously through the system, block to block, in simulated time. The transfer of a transaction from one block to another occurs instantaneously at a specific time when some change of system condition occurs. In our simulation, a transaction is an aircraft and our blocks represent activities such as preflight maintenance, LRU failure generation, and orbit. A transaction also has parameters which record characteristics and numerical data that can affect the way a transaction is processed. For example, each aircraft is identified by plane number, and associated with each plane number is the elapsed time into the simulation and the number, type, and time to failure of all LRUs on that aircraft. Associated with the systems being simulated are permanent entities, such as maintenance support equipment and

maintenance personnel with specific skills, both of which operate on the transaction.

The computation in this type of simulation consists to a large extent on keeping track of where individual items are at any particular time and moving them along from component to component. The result of a simulation run takes the form of statistics which describe the behavior of the simulated system during the run and indicate how many items passed through the system in a given period of simulated time. GPSS allows the user to capture time and frequency statistics using simple, but efficient, commands, thus avoiding the cumbersome code required by a language such as FORTRAN.

For example, MEP, our measure of effectiveness, is obtained simply by examining the “utilization” figure of the MEP STORAGE entity. Other statistics on number of aircraft sorties flown, number of air aborts, and frequency of aircraft groundings are also easily obtained.

The features of GPSS are particularly useful in the “Aircraft Maintenance Module” of the simulation program, which executes the activities of the “Unscheduled” and “Preflight” Maintenance blocks shown in Figure 1.

Figure 2 represents the logic flow through the aircraft maintenance module. In the current model there are many LRUs which must be repaired in-series while other LRUs permit

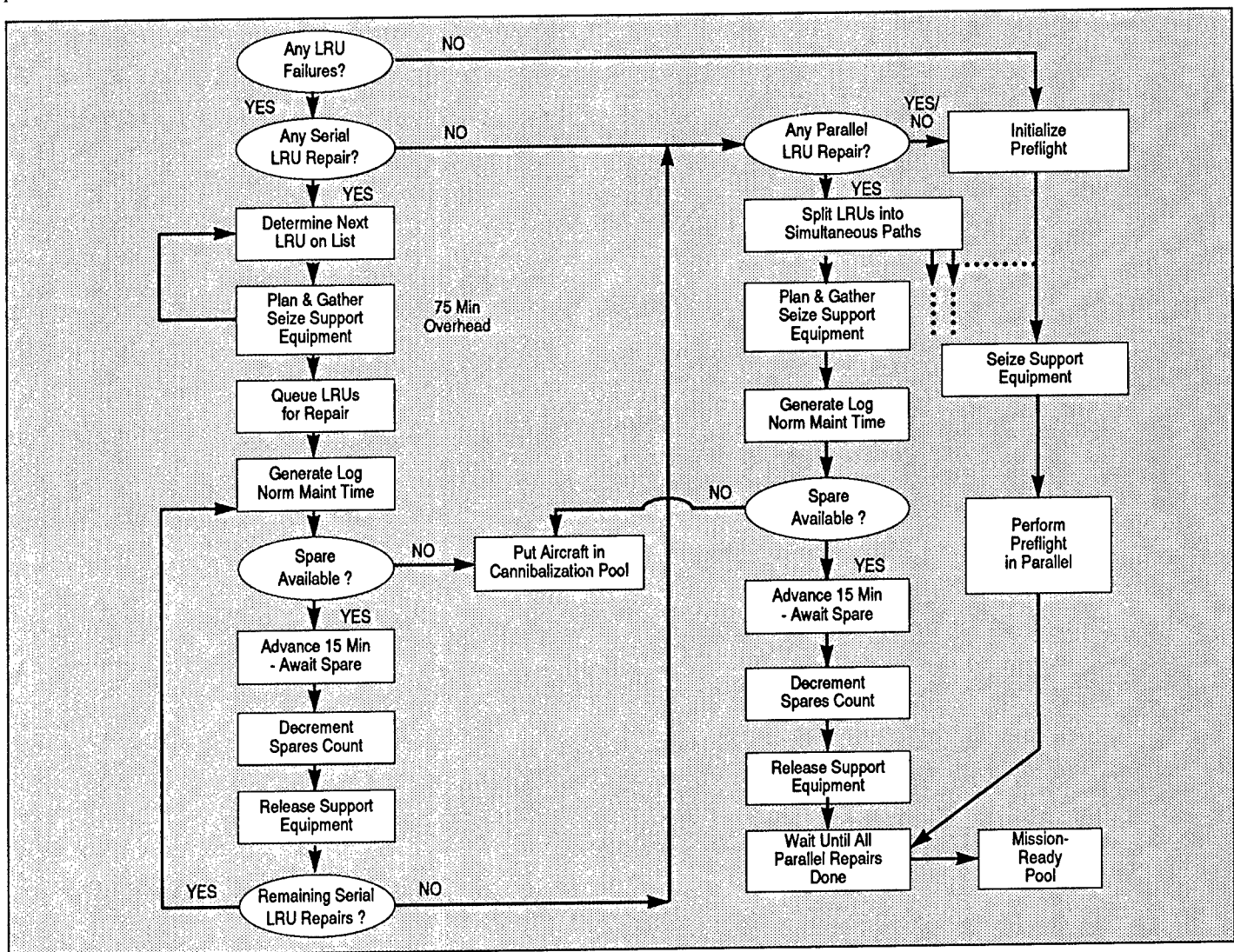

Figure 2. Aircraft Maintenance Module.

parallel repair. Serial LRU repairs must be carried out sequentially, and parallel maintenance allows simultaneous repair of multiple LRUs.

As shown in Figure 2, each LRU repair action consists of the following steps:

- (1) Plan administrative time - 15 minutes.
- (2) Gather/connect required support equipment - 1 hour.
- (3) Identify and obtain necessary LRU spare - 15 minutes.
- (4) Carry out LRU remove-and-replace action - time generated from sampling appropriate lognormal distribution.

The times assumed for the first three steps are based on user requirement documents and Air Force experience with the E-3 Airborne Warning and Control System (AWACS).

The AWACS is also a modified Boeing 707 radar-carrying aircraft platform. It has a similar mission to Joint STARS. The AWACS is designed to detect airborne targets, whereas Joint STARS is being developed for surveillance of ground-moving targets.

For separate LRU repairs performed in parallel, any of the four steps mentioned may overlap from one repair action to another—assuming the required support equipment and maintenance personnel are available. For serial repair actions, steps (1) and (2) are still allowed to overlap, but steps (3) and (4) are not—since they essentially seize sole control of the aircraft. Thus, while the first serial LRU repair is going through steps (3) and (4), the second serial LRU repair may complete steps (1) and (2), but may go no further—until the first serial LRU repair is completed and releases the aircraft.

The handling of simultaneous sets of activities is made particularly easy by GPSS. For example, once the standard sequence of LRU maintenance activities for an aircraft has been established, GPSS allows the transaction representing the aircraft to be “split” and each copy to proceed independently for as many parallel LRU repairs that must be addressed. At the same time, GPSS initializes the Preflight Maintenance chain which is treated as a parallel maintenance action. The flow chart in Figure 2 representing this unique logic thus has the appearance of going in multiple directions from the same decision point.

SRA Simulation Results

Because the computer simulation is stochastic, the value of MEP, as well as other parameters, will change from one computer run to another. For that reason, multiple computer runs were made with each set of input parameters; and various statistics, including average, standard deviation, and range, were computed over these multiple runs.

Initially, 8 computer runs per case were used, where each run represented one replication of a 30-day mission deployment for a particular set of input parameters. This was later increased to 10 and then 30 runs per case. By setting up around-the-clock runs, 30 run cases (which, on the average, required 4.5 hours) were made to increase statistical confidence in the resulting output. These runs were made on an IBM PC/AT with a math coprocessor.

One aspect of GPSS which is relatively cumbersome is data input and output. However, we were able to interface GPSS with a FORTRAN input/output routine which increased program execution speed by more than a factor of three and also allowed for batch processing of multiple data sets.

There were many different variations used for input parameter values and alternative strategies analyzed in the numerous runs we made of the SRA simulation model. The number of Joint STARS aircraft deployed was obviously an

important factor for mission coverage. Another factor which quickly showed its significance was the confidence level for stockage of spare LRUs. Our mission scenario, in accordance with initial program planning, called for no resupply during the 30-day deployment. Thus the initial payload of spares was a critical limiting factor in keeping aircraft airborne. Table 1 shows the MEP results obtained by looking at 3, 4, and 5 aircraft deployments, respectively, and also by varying the spares confidence level. High confidence represented taking the number of spares required for each LRU type in order to be at least 95% confident of lasting through the 30-day deployment. The average spares confidence level is determined by calculating the average number of failures expected for each LRU type; i.e., it equals the average 30-day demand.

# of A/C	Spares Confidence Level	
	High	Average
5	98% (95 - 99%)	90% (64 - 99%)
4	96% (89 - 98%)	79% (57 - 89%)
3	88% (72 - 94%)	63% (42 - 82%)

Table 1. MEP Sensitivity.

The results in Table 1 indicate a significant increase in MEP due to the increase in the spares confidence level. In fact, by interpreting these results, one can see that starting from a 3-aircraft, average spares level deployment posture with an average MEP of 63%, there are two ways to reach a 90% MEP level. One way is to deploy 2 additional Joint STARS aircraft, and the other is to increase the spares level. The cost differential of these choices is significant!

Table 1 also shows the range of MEP values (in parentheses) which were realized in the 30 computer runs for each case. In establishing a mission deployment posture which provides an acceptable level of mission effectiveness, the fluctuation in MEPs realized on successive deployments is certainly an important factor to the Air Force. Thus the table estimates, in the 5-aircraft, average spares level case, that, even though the average MEP level is 90%, on about 1 out of every 30 deployments it could be as low as 64%.

In particular, the range of MEP scores obtained from 30 simulation runs, as shown in Table 1, can be used to establish a confidence interval for the degree of fluctuation in achieved MEP levels. To determine the confidence that this 30-sample range will cover some proportion—say 90%—of all future MEP scores, we can apply the theory of *statistical tolerance levels* (3:193). For this example, the confidence is 82%.

An important statistic calculated by the SRA simulation program is the number of aircraft grounded due to lack of LRU spares. This statistic helps explain some of the results shown in Table 1. In fact, in the 5-aircraft case with an average confidence spares level, at least 1 aircraft was grounded on all 30 simulation runs. On 20 out of 30 of the computer runs, at least 3 aircraft were grounded, and on 2 of these runs, all 5 aircraft were grounded before the end of the month's deployment. By contrast, under the high confidence spares level, 15 of the simulation runs were completed without a single aircraft being grounded, 2 aircraft were grounded only twice, and 3 or more aircraft groundings never occurred in the 30 computer runs.

The sensitivity of MEP to various changes in other input factors was also examined. For example, if all the LRU MTBF

values were degraded, then, of course, the MEP estimates decreased; but they decreased much more sharply in the average spares confidence level case than when a high confidence level for spares was used.

Somewhat surprisingly, the IFR strategy was found to have a very modest impact on improving the MEP. This conclusion seemed to be due to the fact that mission coverage is lost while in-flight repair is carried out, and a relief aircraft can arrive in little more than an hour's time. Since relatively few IFR failures are predicted for a 30-day deployment, the gain in mission coverage is small.

Similarly, the strategy of allowing a one-hour orbit extension when no relief aircraft is available proved to have a smaller impact than expected. However, in contrast to IFR, allowing the option for extended orbits requires no additional training, hardware, or design effort, so we might as well take advantage of it.

A significant positive result was that reductions in the original maintenance manning figures seemed not to produce a great decline in the estimated MEP.

Due to recent program cost constraints, the Air Force has asked if a platform other than the Boeing 707 could provide a more cost-effective solution to supporting the Joint STARS mission. We examined several alternative platforms with the SRA model and discovered that the different respective sortie duration times; i.e., airborne flight times without refueling, were the dominant factors impacting the respective achieved MEPs. Figure 3 shows the impact of varying the sortie duration time while keeping all other factors fixed and using a high confidence spares level. (The Boeing 707 has a 10-hour sortie time.) Note that to achieve a 90% MEP level, for example, either 3, 4, or 5 aircraft are required, depending on the achievable sortie duration time of the aircraft platform chosen.

Numerous other results and statistics (the distribution of aircraft maintenance turnaround times) were produced, and the SRA model continues to serve as a flexible tool for evaluating proposed changes in system design and support characteristics.

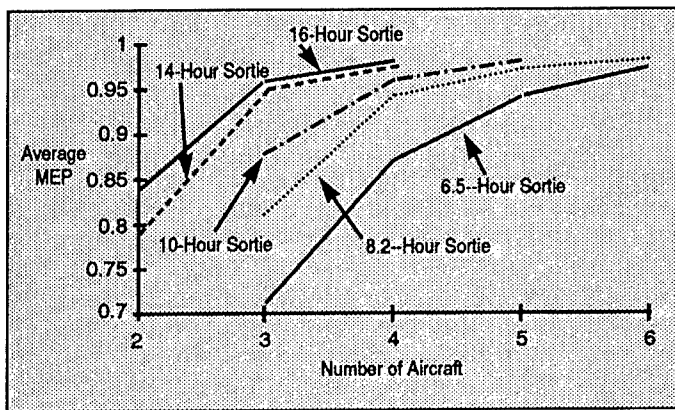

Figure 3. Impact of Sortie Duration Time.

Validating the SRA Model

It is a difficult question in general to determine whether a computer simulation model will generate results which will correspond to real-world experience. Such a state will be realized only if the following three conditions are satisfied:

- (1) All the critical activities and logical interdependencies of the system have been identified.
- (2) Accurate input data has been obtained.
- (3) The model has been programmed correctly.

Even if these conditions are thought to have been met, still greater confidence in a model may be obtained by executing it on an existing similar system and having its results accurately coincide with known experience.

Our effort in identifying the key Joint STARS mission activities and logic flow has already been described. The effort to establish a good input database was also a formidable task.

The current PME data (LRU list, R&M data, and support equipment requirements) were gathered from contractor documents such as Logistics Support Analysis Submittals, Life Cycle Cost Reports, and R&M Reports, as provided by the prime contractor (Grumman Aerospace Company). The reliability figures were further derated to account for induced malfunctions and "no-defect-found" maintenance actions. Airframe data, such as R&M data for critical subassemblies and LRUs, preflight and postflight maintenance activities, support equipment requirements, and spares kits, were generated for the most part by commonality with available data from similar aircraft, such as the AWACS and KC-135.

Reliability estimates for aircraft subsystems were further broken out into MTBFs for the following types of maintenance actions:

- (1) Failures causing air aborts.
- (2) Failures requiring LRU removals.
- (3) Other actions not requiring LRU removals (equipment recalibration, adjustments, minor part replacement).

AWACS experience, in particular, indicates that only a minority of maintenance time is spent on LRU removals. This breakout of MTBFs by type of maintenance action allows the computer simulation model to better track aircraft status and utilization of resources.

Information on mission scenarios such as forward operating base (FOB) deployment planning and decision logic for various mission activities (for instance, when a mission is aborted) was generated from user requirement documents and consultations with the AWACS maintenance personnel at Tinker AFB, Oklahoma; Tactical Air Command (TAC) users at Langley AFB, Virginia; and Joint STARS Program Office logistics personnel.

For the purpose of providing an independent check on the operation of our computer simulation model, we were able to develop several mathematical formulas that apply to restricted mission conditions or to selected components of the model. As an example, we developed a formula to derive the probability distribution of the time to mission critical failure (MCF) for an individual aircraft sortie. From this formula we were able to directly compute the probability of an air abort and other quantities which could be compared to analogous computer simulation results. This comparison had to be made in the case where in-flight repair is not allowed.

To facilitate this derivation, we introduce the following notation:

- (1) There are M distinct LRU types in the system.
- (2) For each LRU type i , at least $k(i)$ out of a total installed number of $n(i)$ must operate to remain in mission capable status so that $n(i) - k(i)$ LRUs of type i are redundant.
- (3) Each LRU of type i has an exponential lifetime before failure with mean equal to $MTBF(i)$.

For any time duration t , we can then invoke the binomial probability formula, to deduce that:

$$P(j,i,t) = \text{Prob}[\text{exactly } j \text{ out of } n(i) \text{ LRUs of type } i \text{ fail within time } t]$$

$$= \binom{n(i)}{j} \left(1 - e^{-t/MTBF(i)} \right)^j \left(e^{-t/MTBF(i)} \right)^{n(i)-j}$$

Note that, to remain in mission capable status through any time t , we can allow anywhere from $j = 0$ through $j = n(i) - k(i)$ failures of LRUs of type i . Since this condition must hold for all M different LRU types, we can calculate the distribution function $F(t)$ of the time T to MCF by:

$$\begin{aligned} F(t) &= \text{Prob}(T \leq t) = \text{Prob}(\text{an MCF occurs before time } t) \\ &= 1 - \text{Prob}(\text{no MCF occurs before time } t) \\ &= 1 - \prod_{i=1}^M \sum_{j=0}^{n(i)-k(i)} P(j,i,t) \end{aligned}$$

Using this formula for $F(t)$, we can determine the probability of an MCF before the end of a 10-hour sortie merely by evaluating $F(10)$. This figure was in close statistical agreement with the results from the associated computer runs.

If we make the additional restricting assumption that an aircraft is always available in the mission-ready pool when an alert is given, then we can use this formula to derive a direct analytic formula for MEP. The results of this analytic MEP formula again agreed closely with similarly restricted computer runs. It was an obviously hopeless task to derive an analytic formula for MEP in the general mission scenario case, which created the need for a simulation model.

As further validation of our SRA simulation model, we made a set of computer runs using an AWACS database. Since the Joint STARS mission in overall structure is very similar to AWACS deployments, the SRA model parameters can be adjusted to closely represent AWACS scenarios. We then could compare simulation results to AWACS experience.

An AWACS database was formed by merging the data we already had on equipment which is common to the Joint STARS and AWACS systems with new data on AWACS-unique subsystems. In fact, we performed multiple computer simulation runs on two different AWACS missions for which we had field data. In both cases, the MEP predicted by our simulation runs corresponded very closely to the orbit coverage actually observed in the field. This result gave us greater confidence in the predictive accuracy of the Joint STARS SRA model.

Summary

The main lesson of the Joint STARS SRA is that a fairly simple, straightforward simulation model can be efficiently constructed using moderate resources (a simulation language on a PC) and still provide timely and accurate feedback to impact a system under development.

The combination of using a computer simulation language on a PC provided us with an ideal development environment. The built-in facilities of the simulation language for creating and automatically tracking system entities, controlling the utilization of support resources, and gathering statistics greatly simplified the implementation of the model. These features and the resulting well-structured code allowed for the rapid determination of the cause-and-effect relationships behind simulation results. Such relationships are often difficult to pin down in more complicated models.

We could also constrain our model development to the level of detail we felt was appropriate and for which data was available. Since our model was easily modified, we were able to quickly implement a basic version and gradually add enhancements later to provide more accuracy and also to investigate particular details or strategies which early results indicated had a strong impact on mission coverage. Overall the SRA model turned out to be a flexible and useful tool. Similar tools should be more commonly used on other military system developments.

Acknowledgements

Captain Mark Locher of the Joint STARS Program Office was a major contributor to the development of mission logic and simulation modeling assumptions, and was primarily responsible for the generation of the SRA model database.

This work was sponsored by the Air Force Electronic Systems Division (AFSC), Hanscom AFB, Massachusetts.

References

1. Air Force Logistics Command (AFLC) Regulation 57-18, *Management and Computation of War Reserve Materiel*, 21 April 1986, Wright-Patterson AFB OH.
2. Crawford, G. B. Project Air Force Report R-3318-AF, *Variability in the Demands for Aircraft Spare Parts*, 1988, The RAND Corporation, Santa Monica CA.
3. Gibra, I. *Probability and Statistical Inference for Scientists and Engineers*, Sections 7.6 and 7.7, 1973, Prentice-Hall, Inc., Englewood Cliffs NJ.
4. Greenberg, S. *GPSS PRIMER*, 1972, John Wiley and Sons, New York, NY.
5. *Hansconian* (ESD Newspaper), Vol. 35, No. 10, 15 March 1991, Hanscom AFB MA., p. 1.
6. Lie, C. H., Hwang, C. L., and Tillman, F. A. *AIEE Transactions*, "Availability of Maintained Systems: A State-of-the-Art Survey," Vol. 9, No. 3, 1977, pp. 247-259.
7. Minuteman Software, *GPSS/PC Reference Manual*, 1986, Stow MA.

Richard Moynihan and Audrey Taub performed the work in the Systems Analysis and Cost Department, The MITRE Corporation, Bedford, Massachusetts.



A Simulation Analysis of a Military Entrance Processing Station

*Thomas A. Feo
Gary A. Minadeo*

*Valentin Novikov
J. Wesley Barnes*

Introduction

Located throughout the United States, each of the 68 Military Entrance Processing Stations (MEPs) function as a one-stop induction point into the United States Armed Forces. Each working day, between 50 and 150 applicants enter a typical MEPS for processing into the Army, Navy, Air Force, Marines, Army Reserve, Army National Guard, and Coast Guard. Unfortunately, applicants do not always finish processing by the 4:00 p.m. deadline and must be housed overnight at government expense. Such applicants are *residuals* who return the next day to finish processing. Avoiding this expense and the inconvenience to the residuals is an important objective; quality applicants may *not* return the next day.

In the study reported here, the present method of operation (PMO) of a MEPS and several future methods of operation (FMO) were modeled and comparative analyses were performed. The goal of the study was to determine cost-effective resource mix requirements for reducing or eliminating residuals and for maximizing the throughput of a MEPS. This study is meaningful for two reasons. First, wartime mobilization would require each MEPS to process a significantly increased demand. Second, as a consequence of upcoming military budget reductions, MEPS operations will almost certainly be consolidated into fewer stations with much larger daily loads.

Model Development

Data Collection

With applicable clearances, subject matter experts working at a selected MEPS provided guidance in modeling service time distributions for all the associated operations in processing applicants. Service times with large historical variance were modeled using a minimum time plus a randomly generated sample observation from an exponential distribution with an appropriate mean. After reviewing several possibilities, this approach was deemed most realistic by the MEPS staff. Other service times were modeled by uniform distributions. Reliable estimates of the percentages of males and females, service selections, and types of processing were obtained from extensive MEPS data for several peak months of the year. *Actual* staffing levels were used to set the resources in the PMO.

Process View of System

A high level process view of a typical MEPS is shown in Figure 1.

ARRIVAL At ARRIVAL, applicants are partitioned into either DEPERS, who have selected the delayed entry program, or SHIPPERS, who are "shipping out" that day to basic training. Historically, applicants have been 60% DEPERS and 40% SHIPPERS. This applicant mix is reflected in all simulated investigations conducted in the study.

SHIPPERS begin arriving at 5:30 a.m. for record checks. After 30 minutes of counseling, they move on to MEDICAL. While no preemption is allowed, SHIPPERS have priority over the DEPERS throughout the entire system. DEPERS arrive in prearranged groups every 45 minutes beginning at 7:00 am. As detailed in Table 1, DEPERS receive two briefings which take a minimum of 22.8 minutes with additional time governed by an exponential distribution with a mean of 7.5 minutes. (All times taken by the various processing steps at a MEPS are detailed in Table 1.)

MEDICAL All applicants arriving at MEDICAL join a queue and await examination by medical technicians. SHIPPERS receive height and weight screening and are subsequently reviewed by a doctor. Similarly, DEPERS are seen both by technicians and doctors where they receive a full physical examination, and a medical and personal item review. As may be observed from Table 1, female DEPERS require substantially more time at this stage than male DEPERS.

RECORDS Clerks code the MEDICAL findings for entry into the applicant's database and make backup copies of all medical forms. In accordance with historical records, 10% of the DEPERS are disqualified for medical reasons and leave MEPS processing at this point. The SHIPPERS attrition is negligible and is not modeled. All other applicants proceed to the control desk to be logged in and then are directed to their respective service counselor.

COUNSELORS A service-specific counselor helps each applicant determine an appropriate job. DEPERS are apportioned as follows: Army 32.83%, Navy 30.73%, Air Force 13.96%, Marines 11.60%, Army Reserve 4.19%, Army National Guard 6.09%, and Coast Guard 0.60%. Apportionment for the SHIPPERS is Army (36.84%), Navy (34.48%), Air Force (15.66%), and Marines (13.02%). The Army Reserve, Army National Guard, and Coast Guard do not have SHIPPERS.

ADMINISTRATION At ADMINISTRATION, SHIPPERS go to ADMIN #1 where contracts are finalized. DEPERS go to ADMIN #1 to obtain their contracts and then to ADMIN #2 for fingerprinting and a pre-enlistment interview. All applicants return to the control desk where they are logged in again and sent to an appropriate senior counselor for final checks and contract signing.

SWEARING-IN CEREMONY The first swearing-in ceremony is performed after the first 10 applicants arrive at this point in the process. Thereafter, the ceremony is performed every 30 minutes. All applicants officially enter the active and reserve service at the conclusion of this ceremony. After swearing in, SHIPPERS await transportation for shipping out. Senior counselors give DEPERS final instructions in preparation for their return at a later date to ship out. The simulation model tracks SHIPPERS until they acquire transportation and DEPERS until they leave their senior counselor.

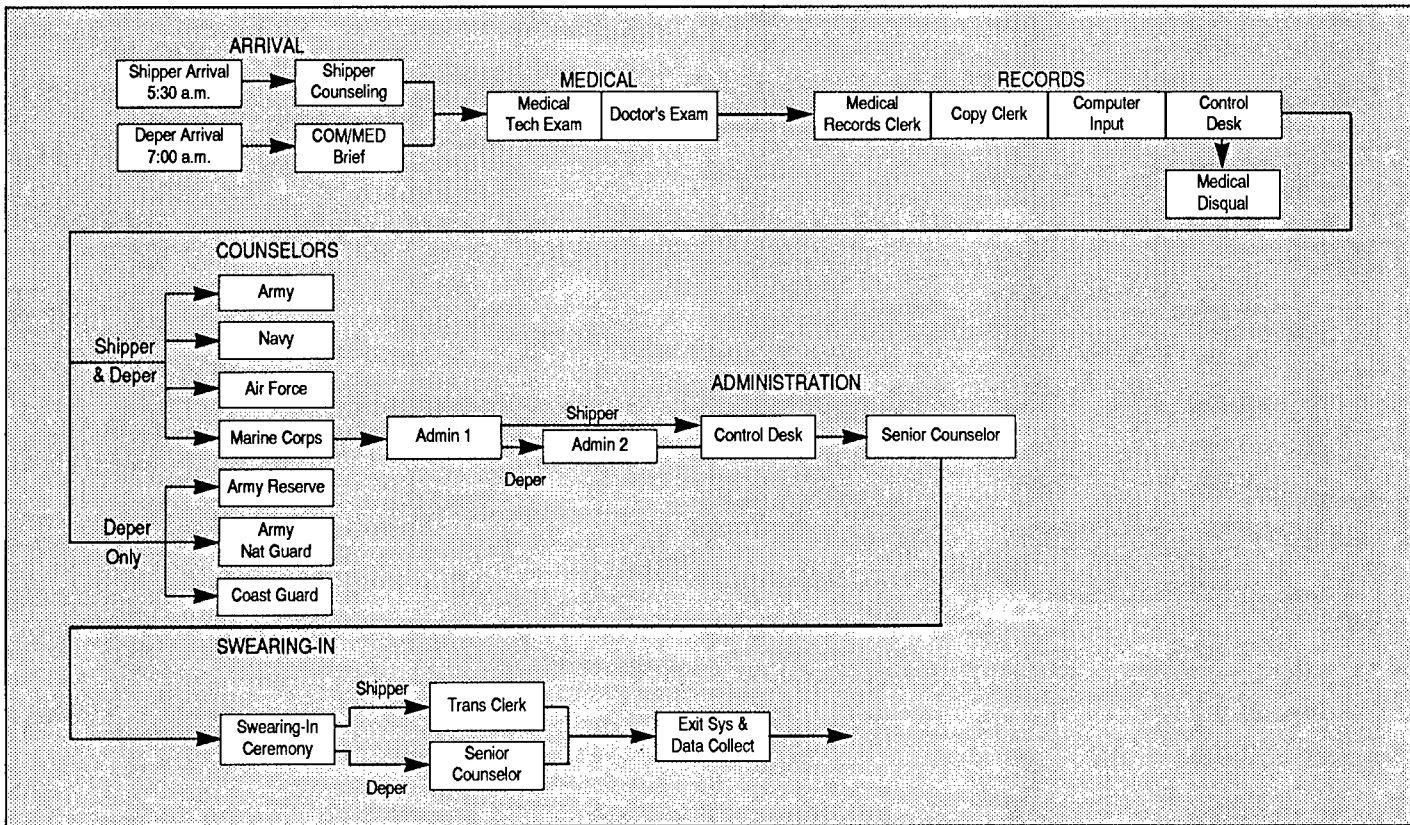

Figure 1. MEPS Process View.

Activity	Duration (All times in minutes)	
ARRIVAL		
Shipper Counseling	30	Deper Com/Med Briefing 22.8 + Ex (7.5)
MEDICAL		
Med Tech Exam		
Shipper	U(5,10)	Deper 25 + Ex(2.4)
Doc Exam		
Shipper	U(5,8)	Deper
		Male 5 + Ex(2.4)
		Female 10 + Ex(2)
RECORDS		
Med Records	U(4,6)	
Copy	U(2,3)	
Comp Input	U(1,2)	
Control	U(1,2)	
COUNSELORS		
Marines	Shipper 5 + Ex(2)	Deper 20 + Ex(5)
Air Force	Shipper 5 + Ex(2)	Deper 15 + Ex(15)
Navy	Shipper 10 + Ex(5)	Deper 20 + Ex(10)
Army	Shipper 20 + Ex(10)	Deper 30 + Ex(30)
Army Res	Deper 10 + Ex(10)	
Natl Guard	Deper 10 + Ex(10)	
Coast Guard	Deper 10 + Ex(10)	
ADMINISTRATION		
Admin1	Shipper U(10, 20)	Deper U(10,15)
Admin2	Deper 3 + Ex(2)	
Control Desk	Shipper U(0.5,1)	Deper 5 + Ex(5)
Senior Counselor	8 + Ex (4)	
SWEARING-IN CEREMONY	U(15,29)	
Shipper Awaits Transport	10 + Ex(5)	
Deper Senior Counselor	7 + Ex (4)	

Ex (μ) = Exponential distribution with mean = μ
 U(a,b) = Uniform distribution with minimum of a minutes and maximum of b minutes

Table 1. Processing Time Durations.

Prior to departing the model, statistics are collected on each DEPER and SHIPPER. These include the total time in the system and the number of applicants finished by 4:00 p.m.

The Simulation Approach

Several process-oriented simulation languages are available. Some examples are SLAM (1), SIMSCRIPT (2), and GASP (3). The SLAM II simulation language was selected because it increases the efficiency of the modeler by providing easily managed building blocks of code. Once the model is coded and run, the simulation language translates these building blocks into an executable program.

These building blocks are easily related to a MEPS. An explanation of selected SLAM terms and how they relate to the general process shown in Figure 1 is:

ENTITIES — The entities in the model are the applicants.

ATTRIBUTE — A "marker" or tag placed on an entity to identify a particular characteristic. Each applicant possesses three attributes: arrival time to the system, gender, and processing type (DEPER or SHIPPER).

RESOURCES — The model's resources are the civilian and military personnel who operate the MEPS. Listed below are the type and number of each resource considered by the PMO:

Doctors. There is one full-time doctor. Part-time hires are based on the projected load for each day. The following formula and table provided by the MEPS staff are used to determine additional need. Points = 1.0 (number of male DEPERs) + 3.0 (number of female DEPERs) + 0.1 (number of male SHIPPERs) + 0.3 (number of female SHIPPERs).

Points	Additional Doctors
1 - 30	1
31 - 65	2
66 - 100	3
101 - 135	4
136 - 170	5
171 - 205	6

Medical Technicians. There are 6 full-time technicians. An additional 4 are on call.

Records Clerks. There are 2 records clerks, 1 for copying, 1 for code input.

Control Desk Clerks. There are 3 control desk clerks.

Counselors. The Army has 6, Navy 3, Air Force 3, Marines 2, Army Reserve 1, Army National Guard 1, and Coast Guard 1.

Senior Counselors. The Army has 1, Navy 1, and Air Force 1. The Marines, Army Reserve, Army National Guard, and Coast Guard each use one of their regular counselors to perform senior counselor functions.

Administration Clerks. ADMIN #1 has 4 clerks and ADMIN #2 has 1.

Transportation Clerk. There is 1 transportation clerk.

QUEUE — Anywhere applicants wait for processing. All MEPS queues, which occur at all processing points, are sufficiently large to preclude any overflow of waiting applicants. It is assumed that applicants will leave a queue only to begin processing by one of the MEPS RESOURCES.

ACTIVITIES — In Figure 1, activities are indicated by the labeled rectangles. Activities have time durations and can divide flow based on the applicant's attributes.

Experimental Design

The scenarios shown in Table 2, which detail the PMO and six FMOs, are an illustrative subset of the resource mixes that were studied. The PMO had a daily input of 83 applicants, 33

SHIPPERs and 50 DEPERs in two briefing groups with 25 applicants each. The lower limits of 6 medical technicians and 3 doctors were used, and all other resources were set at the nominal staffing levels. FMOs 1, 2, and 3 established a comparative basis for each of the three proposed demand levels (100, 125, and 150). The number of assigned medical technicians remained at 6 and the number of doctors was determined by the MEPS staff formula given earlier. FMOs 4 to 6 had the same demands as FMOs 1 to 3, respectively. These three scenarios, out of the many resource mix strategies studied, were the most cost-effective way to achieve the project goal of minimizing the number of residuals and maximizing the MEPS throughput.

The simulation model was coded using SLAM II (Version 4.0), and the experiments were run on an IBM PS/2 Model 80 with a math coprocessor under DOS 4.01. The PMO and each FMO model were run for 100 simulated days with total run times ranging from 200 to 800 CPU seconds. Model validation was accomplished by reviewing the PMO results with the MEPS Operations Officer and by comparing results against historical information.

SCENARIO	DEPERS/SHIPPERs	GROUPs	TECHs/DOCS	COUNSELORs	CLERKs
PMO	50/33	2	6/4	17	12
FMO 1	60/40	2	6/4	17	12
FMO 2	75/50	3	6/5	17	12
FMO 3	90/60	3	6/5	17	12
FMO 4	60/40	2	7/4	17	12
FMO 5	75/50	3	10/5	17	13
FMO 6	90/60	3	10/5	19	14

Table 2. Scenarios.

Results and Analysis

The average daily results for the PMO and FMO models are shown in Table 3. The largest standard deviation observed on the mean finish times was 14 minutes (FMO 5). The following estimated costs per person per day (provided by MEPS staff) were used:

Residual	\$30
Clerk	\$56/day
Technician	\$74/day
Counselor	\$79/day
Doctor	\$162/day

The figures in the last column of Table 3 are the average daily cost to the MEPS for residuals and personnel divided by the total applicant demand.

FMOs 1 to 3 illustrate how the MEPS will respond to increasing demand under current resource allocation guidelines. MEPS personnel predicted that these scenarios would exhibit severe bottlenecks at **MEDICAL** and **COUNSELORs**. The simulation results did not substantiate those predictions. **MEDICAL** adequately handled increased demand by means of the scheduled increases in its resources. In each of the FMOs, the waiting times in medical are minimal (less than 10 minutes). However, several **ADMINISTRATION** areas, including copying and computer input, had excessive waiting times and queue lengths. Counseling was also inadequately staffed when demand reached 150 applicants a day.

FMOs 4 to 6 efficiently adjust the PMO resources so there are zero residuals on an average day; i.e., a mean finish time no later than 1600 hours (4:00 p.m.). FMO 4 requires only a simple

SCENARIO	MIN FINISH	AVERAGE FINISH	MAX FINISH	AVERAGE RESIDUALS	COST/ APPLICANT
PMO	1456	1512	1552	0.0	\$ 37.43
FMO 1	1537	1600	1644	3.2	\$ 32.03
FMO 2	1639	1711	1809	11.6	\$ 28.94
FMO 3	1814	1858	2003	32.8	\$ 28.35
FMO 4	1519	1540	1635	0.5	\$ 31.96
FMO 5	1512	1537	1644	0.8	\$ 29.16
FMO 6	1527	1555	1702	1.8	\$ 25.93

Table 3. PMO and FMO Results.

adjustment of an additional medical technician. An average finish time less than 1600 (with 0.5 average residual) is achieved at an additional cost above the PMO of \$74 a day for the technician and \$15 a day for residuals. For the same demand level, FMO 4 yields a slightly better cost-effective operation than FMO 1. FMO 5 requires the maximum of 10 technicians and 1 additional RECORDS clerk. The gain of nearly 11 fewer residuals than in FMO 2 is achieved at the very acceptable cost of 22 cents per applicant.

The demand level in FMOs 3 and 6 presented a challenge. With an increase of 67 applicants over that in the PMO, the system is taxed. A second records code input clerk, along with an additional counselor for both the Army and Navy, is made available in PMO 6. It is interesting to note that even with the cost of all of the additional personnel in this scenario, the cost per applicant drops substantially because of the significant reduction of 31 residuals per day.

Conclusions

This study demonstrates the capabilities of simulation in analyzing and identifying efficient resource mix scenarios which meet the criterion of leaving no applicants in a MEPS after 4:00 p.m. For demand levels of 100, 125, and 150 applicants, scenarios were found which efficiently achieve that criterion.

Several refinements to the model could be made. The service time distributions and input probabilities and proportions could be polished by means of further on-site studies. The model could also be extended to depict the MEPS interface with the Recruiting Commands and the Training Commands. In such a model, the entire process of induction from initial contact to arrival for active duty would be considered.

Acknowledgements

We would like to acknowledge the assistance in the initial formulation of the simulation model that was provided by L. Franks, S. Joshi, D. McAllaster, and B. Okanla.

References

1. Pritsker, A. Alan B. *Introduction to Simulation and SLAM II*, Halstead Press, John Wiley & Sons, New York NY, Third Edition, 1986.
2. Russell, E. C. *Building Simulation Models with SIMSCRIPT 11.5*, CACI, Inc., Los Angeles CA, 1983.
3. Pritsker. *The GASP IV Simulation Language*. John Wiley & Sons, New York NY, 1974.

Thomas Feo and coauthors are professors in the Department of Mechanical Engineering, University of Texas at Austin, Austin, Texas.



Most Significant Article Award

The Editorial Advisory Board has selected "The Logistics Dilemma" by Colonel Joseph B. Corcoran, Jr., USAF, as the most significant article in the Spring 1992 issue of the *Air Force Journal of Logistics*.



CURRENT RESEARCH

Air Force Logistics Management Agency (AFLMA) FY93 Program

Periodically, AFLMA contributes to this portion of the Journal. Our last contribution appeared in the Summer 1991 edition. Many of the projects in that listing have been completed, and we sincerely hope the Air Force logistics community is more effective because of them.

Cooperative efforts outside the Agency have been outstanding. Personnel from MAJCOMs and bases have helped by providing "real world" data, test-bed sites, survey participants, "sounding boards" for new approaches, and key recommendations on better ways to solve logistics problems.

Below are our top projects for FY93. If you are interested in any of these projects, please contact the project officer. If commercial lines are used, dial Area Code (205) 416-plus the last four digits of the DSN number.

Contracting

Analysis of Award-Fee Contracting Technology, LC922155

Objectives: (1) Analyze the entire award-fee process from initial project concept through award and administration of fixed-price award-fee contracts. Recent Air Force Audit Agency (AFAA) audits have uncovered several deficiencies in how fixed-price award fees are solicited, awarded, and administered to include award-fee board preparation, board membership, and the actual award process. This effort will supplement the *Base Level Award-Fee Guide* (LC850705) published in 1988. (2) Look at the decision-making process and criteria for using fixed-price award-fee contracts.

Capt Thomas D. Robinson, AFLMA/LGC, DSN 596-4085

Analysis and Improvement of Supply/Contracting Leadtimes, LC922156

Objectives: (1) Analyze and identify methods to improve the commodity acquisition process, to include (a) encouraging commodity buyers to solicit the best possible delivery on all awards, including the potential of expending a premium for the expedited delivery of priority requirement; (b) demonstrating the benefits of loading Automated Purchase Orders (APOs) in the Base Contracting Automated System (BCAS) and maximizing the creation and use of Blanket Purchase Agreements (BPAs) and Delivery Orders (DOs); and (c) identifying the management tools available to contracting personnel that are the best indicators and measurements of effective contract placement processes and total customer support. (2) Develop a program to include sample reports, instructions, and training materials that can be used at any operational contracting squadron to improve the commodities acquisition process and supply/contracting leadtimes.

Capt William J. Hauf, AFLMA/LGC, DSN 596-4085

Transportation

Development of a Cargo Movements Database, LT912074

Objective: Establish a database using data retrieved from the Air Force Logistics Information File (AFLIF).

Maj Katherine Solters, AFLMA/LGT, DSN 596-4464

Update of Freight Documentation Automation (FDA) Programs, LT922157

Objective: Update the Surface Freight and Packing and Crating programs of FDA and distribute programs and manuals to users.

Capt Emily J. Scarpa, AFLMA/LGT, DSN 596-4464

Maintenance and Munitions

Weapons Load Crew Management Program, LM902057

Objective: Develop and test a standard prototype microcomputer weapons load crew management program.

Maj John L. Wood, AFLMA/LGM, DSN 596-4581

Flight-Line Maintenance Enhancements, LM922153

Objectives: (1) Help the Air Combat Command (ACC) determine how their bases, using existing or readily available equipment, parts, and personnel, will be able to perform repairs on XB3 and XF3 aircraft parts under Project Gold Flag, a command initiative for units to recover, repair, and reuse XB3 and XF3 aircraft parts. (2) Conduct a test of Gold Flag repair, collect data, and report on the successes and failures of the program.

Capt William P. Quinones, AFLMA/LGM, DSN 596-4581

On-Equipment Maintenance Data Collection (MDC) Reduction Test, LM990128

Objective: Provide consulting service to HQ USAF/LGMM, Headquarters Air Mobility Command (HQ AMC), and Headquarters Air Force Materiel Command (HQ AFMC) for the test of the new maintenance data collection (MDC) process described in the AFLMA study, Project LM912082, and for the process action team that will monitor the HQ AMC test.

Maj Scott A. Taggart, AFLMA/LGM, DSN 596-4581

Depot Level Maintenance Data Collection (MDC) and Asset Management, LM922159

Objectives: (1) Review Asset Management and MDC processes at the depot. Study will include possible technologies to use as "passive" data collection devices. (2) Focus on methods to improve the tracking and reporting process using existing and planned standard systems.

Maj Steve R. Kierce, AFLMA/LGM, DSN 596-4581

Use of Film Versus Aircraft Painting

Objective: Determine if polyester aircraft film is a cost-effective alternative to aircraft paint presently in use.

Capt Edward C. Stalker, AFLMA/LGM, DSN 596-4581

Supply

Analysis of the Depot Repair Process, LS92212

Objectives: (1) Analyze the process of inducting assets into depot repair. Two of the key aspects of this process are the tradeoffs between batch size, production efficiency, and responsiveness to customer demands, and the impacts and cost of assuring component part availability. (2) Evaluate alternative methods, procedures, and policies for accomplishing the depot repair functions most efficiently and effectively from a total system perspective. (3) Recommend any changes to existing methods, procedures, and policies which our analysis and evaluation processes indicate will enhance the overall logistics support process.

Capt Bradley D. Silver, AFLMA/LGS, DSN 596-4165

Continued on page 41

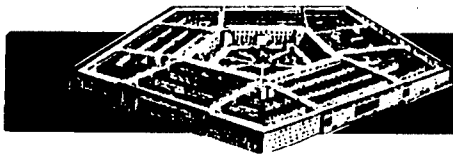

USAF LOGISTICS POLICY INSIGHT

Tactical Shelters

Within the next five years, the Air Force expects to have an inventory of 1,700 tactical shelters, while the DOD will have nearly 10,000 overall. The shelter solves many facility related problems, but its size creates several challenges to the Defense Transportation System. Shelter users should be able to identify the transportation system which moves the shelter from the ground at their home base, through the airlift or sealift system, and onto the ground at the deployment location. If users do not know how their shelter will transfer through this system, there is a big hole in their deployment scheme. Users are also responsible for a part of the movement. The Air Mobility Command, Military Traffic Management Command, Military Sealift Command, and overseas commanders share the remaining responsibility; but they CANNOT do their job unless shelter users identify movement requirements to them. (Lt Col Ed Buchman, AF/LETC, DSN 227-4742)

Two Levels of Maintenance

USAF aircraft maintenance is currently based on three levels of maintenance: organizational, intermediate, and depot. Organizational (flight line) and intermediate levels (support shops) are found at base level, while depot functions are performed at Air Logistics Centers (ALCs). Downsizing of the USAF prompted a closer look at more efficient ways to accomplish three levels of maintenance. Given the cost for equipment and manpower to support intermediate level functions, the Secretary of the Air Force requested that we look at a concept to expand two levels of maintenance to currently fielded systems. Following multiple MAJCOM meetings, the two levels of maintenance were defined, each aircraft's commodities were reviewed, and a thorough cost-benefit analysis was conducted by mission design

series. The results of this review were then briefed to the Secretary, who approved the implementation of two levels of maintenance. The Air Staff is working along with the MAJCOMs to develop an implementation plan for each weapon system to convert between FY94-97. (Lt Col JoAnne Rodefer, AF/LGMM, DSN 227-3523)

Phaseout of Chemicals

On 11 February 1992, President Bush announced the US will stop producing chemicals that deplete the earth's ozone layer by December 1995, a four-year acceleration from the previous phaseout date of December 1999. What does this have to do with logistics? Plenty. These chemicals are also known as chlorofluorocarbons (CFCs), freons, and halons, and are used for everything from refrigeration, to cleaning solvents, to fire protection. Every weapon and support system uses these chemicals for something. We have aircraft and pods that use freon in their onboard cooling systems; many of the maintenance procedures in our technical orders call out CFCs as cleaning solvents; and most of our aircraft carry halon onboard for fire protection. Approximately 90% of Air Force use of these chemicals is as cleaning solvents. Item managers, systems managers, program managers, process engineers, environmental managers, and commanders should all be aware of how the phaseout of these chemicals will affect their operations, take an active role in finding and adopting alternatives, and establish inventory management and recycling procedures for uses they cannot eliminate before 1995. Policy guidance is contained in AFR 19-15, *Pollution Prevention Program*, but the timetables in the regulation have been superseded by the President's announcement. (Mr Adam Antwine, AF/LGMM, DSN 227-1052; Maj Doug Van Mullem, SAF/AQXM, DSN 227-5023, Maj Tom Morehouse, AF/CEVV, DSN 297-0276; Lt Col Tom Harper, HQ AFMC, DSN 787-5567)

Continued from page 40

Supply Wartime Planning and Execution Guide Revision, LS922136

Objectives: (1) Update existing guide to include changes based on Desert Shield/Storm. (2) Provide a single source of information for supply activities to implement during employment. (3) Determine the best method for incorporating the *Supply Wartime Planning and Execution Guide* (SWPEG) into AF Manual 67-1, *USAF Supply Manual*, or another appropriate Air Force regulation.

Capt Raymond T. Daly, Jr., AFLMA/LGS, DSN 596-4165

Communications-Electronics (C-E) Initial Spares Support List (ISSL) Regionalization, LS922152

Objectives: (1) Quantify the performance of C-E ISSLs which have already been fielded to determine the need and scope of a regional stockage policy. (2) Based on the current performance indicators, develop a requisition policy which would optimize the distribution and use of existing C-E ISSL assets. (3) If a regionalized stockage policy is warranted, develop regionalized stockage management policy for current C-E ISSLs and a stockage policy model for future C-E ISSLs. (4) Describe and quantify operational impact and associated storage and

transportation costs of the model. (5) Measure the performance of the new stockage policy and describe any advantages and disadvantages.

Capt Paul L. Bunker, AFLMA/LGS, DSN 596-4165

Logistics Plans

Unit Type Code (UTC) Life Cycle Study, LX922148

Objective: Conduct a study of UTC "life cycles" to include the current system, perceived problems with the system, and recommendations for improvements. The project must be completed in 90 days to meet the needs of the user.

Capt Janice R. Irving, AFLMA/LGX, DSN 596-3535

War Reserve Materiel (WRM) Requirements Handbook, LX922147

Objective: Develop a handbook which explains the WRM requirements determination process and examine the various methodologies used to compute the Non-nuclear Consumables Annual Analysis (NCAA), War Consumables Distribution Objective (WCDO), War Plans Additive Requirements Report (WPARR), and Fuels Logistical Area Summary (FLAS).

SMSGt Penelope A. Lynn, AFLMA/LGX, DSN 596-3535



General Bernard Randolph, then Commander of AFSC, dedicates the RAFB Museum's display of black aviators in early 1988.



Another recently acquired aircraft display is the SR-71 "Blackbird." It is the world's fastest aircraft.



This Lockheed F-80C "Shooting Star" was one of the Museum's first aircraft displays.

