

FALL
1990

AIR FORCE JOURNAL ^{of} LOGISTICS

20040601 120



BEST AVAILABLE COPY

DISTRIBUTION STATEMENT A:
Approved for Public Release
Distribution Unlimited

AFRP
400-1

VOL XIV
NO 4

AIR FORCE JOURNAL LOGISTICS

CONTENTS

FALL
1990

ARTICLES

- 1 **Computer Integrated Repair—What Is It? Who Wants It? Why?**
Colonel Daniel H. Weiss, USAF
- 7 **MRP II in AFLC Maintenance Planning and Control**
W. Steven Demmy
Anthony J. Giambrone
- 14 **Future Paint Stripping Techniques for Aircraft Corrosion**
Captain Michael J. Then, USAF
Lieutenant Commander Donald C. McNeeley, USN
- 17 **Distribution Priority System: Time for a Change?**
Major Donald E. Hamblin, USAF
- 22 **Fighter Design From the Soviet Perspective (Part I)**
Richard D. Ward
- 35 **Logistics Support Limitations in the Vietnam War:
Lessons for Today's Logisticians**
Major Benjamin L. Dilla, USAF
- 39 **Using Goal Commitment to Improve Performance**
Captain Randal A. Gescheidle, USAF
Major Kenneth R. Jennings, USAF, Retired



Honorable John J. Welch, Jr.
Assistant Secretary of the Air Force
Acquisition

General Charles C. McDonald
Commander
Air Force Logistics Command

Lieutenant General Henry Viccellio, Jr.
Deputy Chief of Staff
Logistics and Engineering, HQ USAF

Colonel Russell G. Stafford
Commander
Air Force Logistics Management Center

DEPARTMENTS

- 12 *Reader Exchange*
- 16 *Current Research*
- 21 *USAF Logistics Policy Insight*
- 30 *Career and Personnel Information*
- 32 *AFIT*

Editors

Lieutenant Colonel David M. Rigsbee
Jane S. Allen, Assistant
Air Force Logistics Management Center

Graphics

Ms Peggy Greenlee

-
- Purpose** The *Air Force Journal of Logistics* provides an open forum for the presentation of issues, ideas, research, and information of concern to logisticians who plan, acquire, maintain, supply, transport, and provide supporting engineering and services for military aerospace forces. It is a non-directive, quarterly periodical published under AFR 5-1. Views expressed in the articles are those of the author and do not necessarily represent the established policy of the Department of Defense, the Department of the Air Force, the Air Force Logistics Management Center, or the organization where the author works.
- Distribution** Distribution within the Air Force is F. Customers should establish requirements through the PDO system, using AF Form 764, on the basis of 1 copy for every 5 logistics officers, top three NCOs, and professional level civilians assigned. If unable to use the PDO system, contact the editor. *AFJL* is also for sale by the Superintendent of Documents, U.S. Government Printing Office, Washington, D.C. 20402. Back issues are not stocked.
- Manuscripts** Manuscripts are welcome from any source desiring to deepen or broaden the knowledge and understanding of Air Force logistics professionals. They should be typed (double-spaced) and be between 1500-3500 words. Figures, graphics, and tables (separate pages) should be numbered consecutively within text. A Z-248 is available if author desires to send a diskette (ASCII file) along with the hard copy of the article (Address: AFLMC/JL, Gunter AFB AL 36114-6693; DSN 446-4087, Commercial (205) 279-4087).
- Refereeing** *AFJL* is a refereed journal. Manuscripts are subject to expert and peer review, internally and externally, to ensure technical competence, correct reflection of stated policy, and proper regard for security.

Computer Integrated Repair— What Is It? Who Wants It? Why?

Colonel Daniel H. Weiss, USAF
Chief, Airborne Electronics Division
Warner Robins Air Logistics Center
Robins AFB, Georgia 31098-5000

Introduction

Computer integrated repair (CIR) is the new approach to the avionics repair process being introduced by the Air Force Logistics Command (AFLC) at its largest airborne electronics repair activity at the Warner Robins Air Logistics Center (WR-ALC). The Airborne Electronics Division (MAI) is in the process of posturing itself to organically repair Low Altitude Navigation and Targeting Infrared for Night Vision (LANTIRN)—the two-pod, Forward Looking Infra Red (FLIR) Laser Designator, Terrain Following/Terrain Avoidance Capable System, which is being manufactured by the Martin Marietta Electronics System Division in Orlando, Florida.

The CIR approach, as the acronym implies, is totally dependent on a large and powerful system of highly integrated computer systems at all echelons of maintenance, and on Martin Marietta. In its application to the LANTIRN system, CIR is commonly known as PLAD (Paperless LANTIRN Automated Depot). PLAD was developed by a joint technical team composed of WR-ALC/MAI and Martin Marietta personnel. Over the past 18 months, they diligently, deliberately, and most tenaciously refined the CIR concept. The team expanded the skeletal requirements contained in the PLAD conceptual definition, identified key components of the hardware system, and ensured the software system will address all needs identified by the primary user—WR-ALC/MAI.

Need for CIR

The need to evolve to a less paper-intensive and, hopefully, a paperless digitized world is an opportunity to introduce CIR as the wave of the future. This is clearly demonstrated by the Computer Aided Acquisition and Logistics Support (CALs) initiatives advocated by the Office of the Secretary of Defense and, within the Air Force Logistics Command, by the Logistic Management Systems (LMS) initiatives, including the Depot Maintenance Management Information System (DMMIS), the Reliability and Maintainability Information System (REMIS), the Air Force Technical Order Management System (AFTOMS), and the Core Automated Maintenance System (CAMS). What

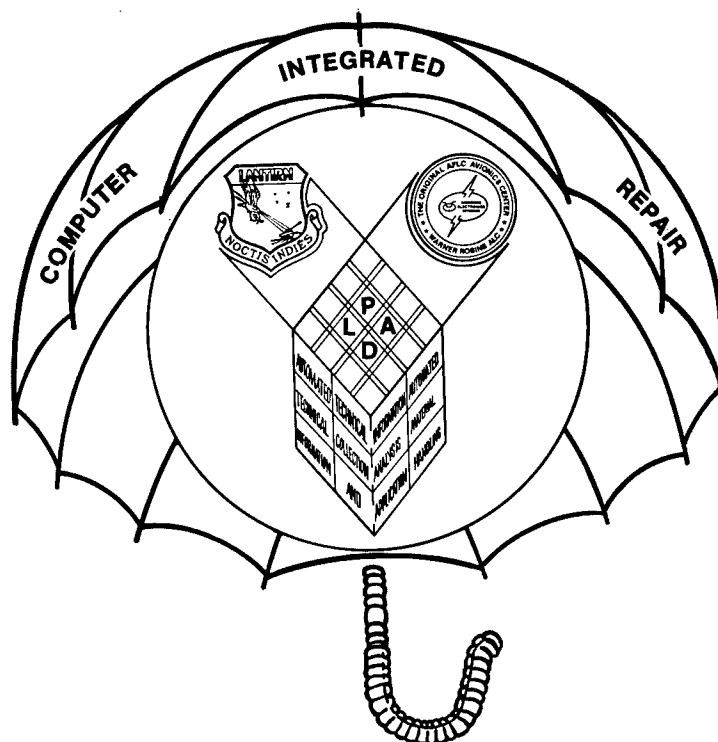

it requires at the repair level is a way to complement, synergize, and leverage the CALS/LMS efforts, thereby addressing the needs of the logistics process through the employment of a cybernetic systems approach. CIR, as embodied in PLAD, employs such an approach.

Another motivation for the introduction of CIR is the increasing need of data capture and collection imposed by our embracing the Total Quality Management (TQM) philosophy. A comprehensive understanding of one's processes is critical. The collection of statistics relative to the processes is essential, all

of which should be pointed toward the identification of out-of-control processes and the reduction of variability to achieve an in-control condition. Although this increased need for data collection further exacerbates the direct worker productivity issue discussed, such collection activity is essential if TQM is to be a success. The challenge is how to collect the data, employ a TQM approach, and simultaneously improve, not only the quality, but also the productivity of the work force. CIR is an answer to that challenge.

The current data systems are rife with shortfalls that have traditionally frustrated the technician's ability to understand the environment to which a failed component has been exposed so the most comprehensive and longest lasting repair action may be implemented. Factors, such as the individual identity of the unit under test, the operational environment within which the unit operates, the period of that operation, the number of times someone operated the unit, the faults the unit experienced in the environment, who effected a repair, where the repair occurred, which test equipment was employed to test the unit, and the results of the test, are all required to provide the best possible repair action. CIR/PLAD addresses these needs.

Another area of critical importance, that under the present repair concept is neither entirely recognized nor addressed effectively, is the relationship of the combination of software and hardware component failures, including built-in test (BIT) effectiveness, test program set (TPS), and efficiency automatic

test equipment (ATE) coverage. It is recognized, and occasionally has been demonstrated, that component failures are the consequence of an operating requirement that exceeds the specification of the component's design. In other words, given the operating environment, the component will fail—most likely prematurely—because the parameters or the operating environment could not be accurately anticipated at the time of system design. Consequently, the system functions in an environment that promotes, if not provokes, failure. In such a circumstance, the original specification of the component must be revised and a replacement component specified that meets the same original operational specification and has a more resilient environment specification. Also, components are removed often because the software (BIT/TPS) that identified them as suspect was either imprecise or incorrect. Yet, in all these situations, no deliberate process has been put in place to routinely determine why something failed or to correlate that failure or suspected failure to the actual circumstance. *The CIR/PLAD process addresses these shortfalls.*

Lastly, in the needs area is the requirement to make avionics maintenance at least an equal with the maintenance practices employed by airframe and propulsion systems. Traditionally, avionics systems have been flown-to-failure. That practice in airframe and propulsion systems was eliminated long ago. It now is appropriate to make the same changes in the support of avionics systems. This change in approach is promulgated by several circumstances. First is the expense of avionics systems. As their cost continues to rise, in many cases dramatically, the effect of employing redundant systems to ensure that at least one will work is questionable. Also, when redundancy is not feasible and one is wholly dependent upon the performance of an avionics system such as a radar, an electronic combat, an inertial navigation, or a communications system, the thought of fly-to-failure—meaning one has no knowledge of when the failure will occur—is unacceptable. The Avionics Integrity Program (AVIP) introduced by Air Force Systems Command's Aeronautical Systems Division (ASD) effectively addresses the avionics fly-to-failure issue; but it, too, depends on the collection and processing of even more data to predict when an avionics component will fail. Predicated on the premise that avionics failures, like propulsion and airframe failures, are the result of the structural deterioration of the components that comprise the unit, an ability must exist to correlate failures by the specific (serialized) unit to its environment in a way that will allow future failures to be predicted with some reasonable degree of accuracy based on the empirical knowledge gained. This, in turn, could lead to another change in avionics maintenance again similar to airframe and propulsion maintenance that would be realized in the replacement of not only items which had failed but also items which are weak—impending failure. *Though revolutionary, the CIR/PLAD process introduces the opportunity to pursue the AVIP nonfly-to-failure approach.*

Paperless LANTIRN Automated Depot

To accomplish all these things, some capabilities must be introduced to the repair process that, heretofore, have either not existed or have been reserved or targeted for other domains. The balance of this presentation will focus on the features of a representative computer integrated repair application—the WR-ALC Paperless LANTIRN Automated Depot. PLAD, as CIR implies, is software intensive and is affiliated with two other major software systems—Computer-Based Technical Orders (CBTOs) and Fielded Systems Support Analysis (FSS/A).

PLAD consists of three subsets: (1) Technical Information Collection, and Analysis and Application, (2) Automated Technical Information, and (3) Automated Materials Handling.

The technical information portion of PLAD receives parametric data inputs from three key areas: the field activities, the depot, and the system (LANTIRN) manufacturer (Figure 1). The basis for providing all information, that is the key data element to which the data collected is addressed, is the line replaceable unit (LRU)/shop replaceable unit (SRU) serial number, which is bar-coded and resident on all LANTIRN LRU/SRUs. In the operational environment, LRU/SRU performance data is collected using two approaches to date untried by the Air Force. First, the pod set's airborne performance is captured in each pod's Data Logging Module (DLM). This module receives information from two sources: (1) The pod itself, which provides the result of pod self-initiated BIT information that is directed by the pod's central computer to be recorded on the DLM. (2) Aircraft dynamic information obtained by each pod monitoring the aircraft's digital data (1553B) buss to gather altitude, attitude, acceleration, deceleration, and turn rate performance data, as well as the aircraft's serial number.

LANTIRN SRU DATA BASE COLLECTION

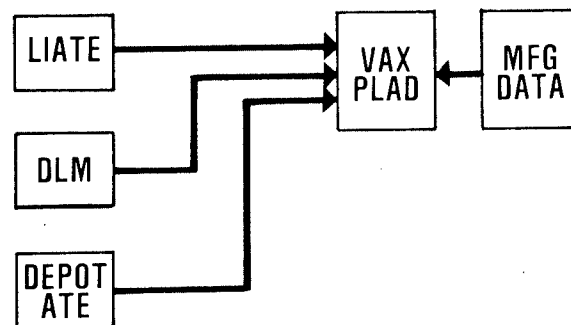

Figure 1.

The parametric data recorded on the DLM is retrieved in one of three ways. It may be downloaded by a technician on the flight line by using a self-powered Portable Data Terminal (PDT); by removing the DLM from a pod and sending it to the intermediate level shop to have the DLM-contained data downloaded by the LANTIRN Automatic Test Equipment (LAITE); or by connecting the pod to the LAITE (when the entire pod is removed and brought to the shop for maintenance). The DLM's data capacity was based on the amount of data Martin Marietta thought would be generated when the pod is operational. Therefore, the DLM does not need to have its data downloaded after every flight; rather, only when desired or convenient, or when the pod experiences a failure. The DLM data is transmitted to the LANTIRN historical database through the FSS/A System.

To facilitate the relation of pod performance to in-flight experiences, the configuration of each pod is maintained in the historical database system. The PDT and/or the LAITE is used to capture pod configuration information. Changes in configuration are transmitted to the historical database. The configuration of the information reflects the pod serial number; the LRU serial number; and, most significant for the depot, the SRU serial number. All parametric performance data is related

to the item's serial number. The result of this activity is the ability to correlate failures with the operational environment.

The other approach introduced in the field to contribute to the CIR process is the capture of parametric data, which details the consequence of exercising the unit under test (UUT)—either SRU or LRU—through application of the TPS, which is designed to generate a series of stimuli and then access the UUT's ability to respond to the stimuli. This parametric data will be directly associated with the UUT's bar-coded serial number. Each time a UUT is exercised, information about the exercising test station is also captured (station's serial number, date calibrated, location, and when preventive maintenance was accomplished, as well as the operation's identity).

The information gathered by the ATE is sent to the intermediate level site's central computer. The ATE information, along with the DLM-gathered information, is then forwarded through FSS/A to the historical database.

At the depot, information is similarly gathered. As in the field, whenever a UUT is exercised, the results of that activity, as well as test station parametric information, are forwarded to the PLAD central computer and then through FSS/A to the historical database. The depot TPS will gather parametric information that has always been available but not captured or employed. That information concerns the specific performance of the UUT that will provide an understanding of the UUT's variation from its designed norm. The intention of gathering this information is to contribute to the identification of UUT components that are performing adequately but are not up to the limits of their specifications. Ultimately, this information will be used for at least three purposes: the identification of weak (versus failed) components; variability reduction; and, eventually, the identification to the field by the depot of those assets anticipated to fail in the near future. The latter activity will be the beginning of a new era in avionics maintenance. This preemptive removal process will begin to curtail the current fly-to-failure approach of avionics systems operations.

The configuration and equipage of the depot will also change as a consequence of the introduction of the CIR approach. Today, each depot technician must go to any one of a number of different locations to gather the resources necessary to complete a repair action. Typically, technical data, in limited copies, is in one location and must be checked out to be used. Parts are ordered through use of technical data that must be translated to complete the forms used to document and control the requisitioning process. UUT history information, which usually is not available, must be obtained from another location. Special tools, interface test adapters, and other unique requirements necessitate the expenditure of time to locate them. Any chemicals required to accomplish a job must be sourced from another area and the UUT to be tested must be sourced from yet another area. All the attendant documentation must be completed—before, during, and after the maintenance action is completed, which is normally done in a special location not necessarily contiguous and/or convenient to the technicians. And, lastly, the technicians' supervision is located in an area distinct from all those previously described, which necessitates that the technicians again relocate if they need to obtain from or provide information to management. Likewise, if any person or agency wants to communicate with the technicians, the person must travel to their location. None of this will be necessary with an activity configured to employ the CIR process.

AFLC's first CIR activity, PLAD, will occupy a 10,000-square foot area, functionally arranged as dictated by the types of subsystems contained in the LANTIRN system.

PLAD's foundation will be a no single point of failure computer cluster, which will be electronically linked to the LANTIRN technicians on the local end and to the historical database on the distant end. To communicate with the PLAD central computer, each technician, along with the appropriate supporting activities—the Electronic Pathology Laboratory, both the hardware and software portions of the LANTIRN operations center, and the LANTIRN software maintenance activity—will be provided computer terminals. Designed with the technician in mind, all the terminals are touch-screen capable, equipped with a bar-code reader and a traditional keyboard. Each technician is provided a terminal. The planned shop layout is illustrated in Figure 2.

To explain the CIR process, I will describe the software that is the heart of the system and the interaction each depot group has with PLAD. To satisfy shop management requirements, a LANTIRN Operations Center (LOC) will be established. The Center will be occupied by LANTIRN production supervision, planning, and scheduling personnel. Via electronic means, predominately cathode ray tube (CRT) displays, and the supporting software, the activities from almost any perspective can be supervised without leaving the LOC. Also, should any technicians require supervisory or any other type of assistance, they can request it electronically from their work station to which the supervisor can dispatch or deliver whatever is required.

The LANTIRN technician work stations are the focal point of the CIR process. Technicians today are not fully productive because of the relocation necessary to interact with almost any supporting process. Not so in PLAD/CIR. All work process requirements are addressed through the technicians' terminal. After identifying themselves to the PLAD system, the serial number of the item to be repaired is identified. This initiates several simultaneous actions. The required technical data is loaded into the technicians' work station, the PLAD central computer hosted TPS file is downloaded to the applicable ATE station, the appropriate test fixtures and special tools, etc., are picked by the Automated Storage and Retrieval System (ASRS) and delivered by an Automated Guided Vehicle (AGV), and the history of the to-be-tested UUT is provided to the technicians.

Before the repair activity begins, the technicians can ascertain what the UUT has experienced since it was manufactured and fielded (Figure 3). They will be told such things as what repair actions have been accomplished on this specific UUT, who did the work, where, on which testers, how long the item operated before it failed, the operational environment within which it functioned, on which aircraft it flew, and what BIT calls were initiated, when, and with what resulting repair action. The technicians are provided analytical capabilities that are neural system-based. The neural system tools should aid technicians in identifying failure patterns and/or effective repair approaches to take when the embedded test equipment software routines are unable to elicit a stimulus response, which indicates where a UUT failure may exist. To further aid the technicians, two free form information-capturing features are provided: a scratch pad to record any technically orientated notes deemed appropriate, but not necessarily related to any official technical data, and a notepad that will allow users to make notes on the technical orders digitally provided to them. Of course, the information recorded by one technician will not be able to be shared with or looked at by anyone other than the one who created it, unless the PLAD resident electronic mail system is used and the information that the technician created is authorized to be transmitted by the originator.

LANTIRN DEPOT

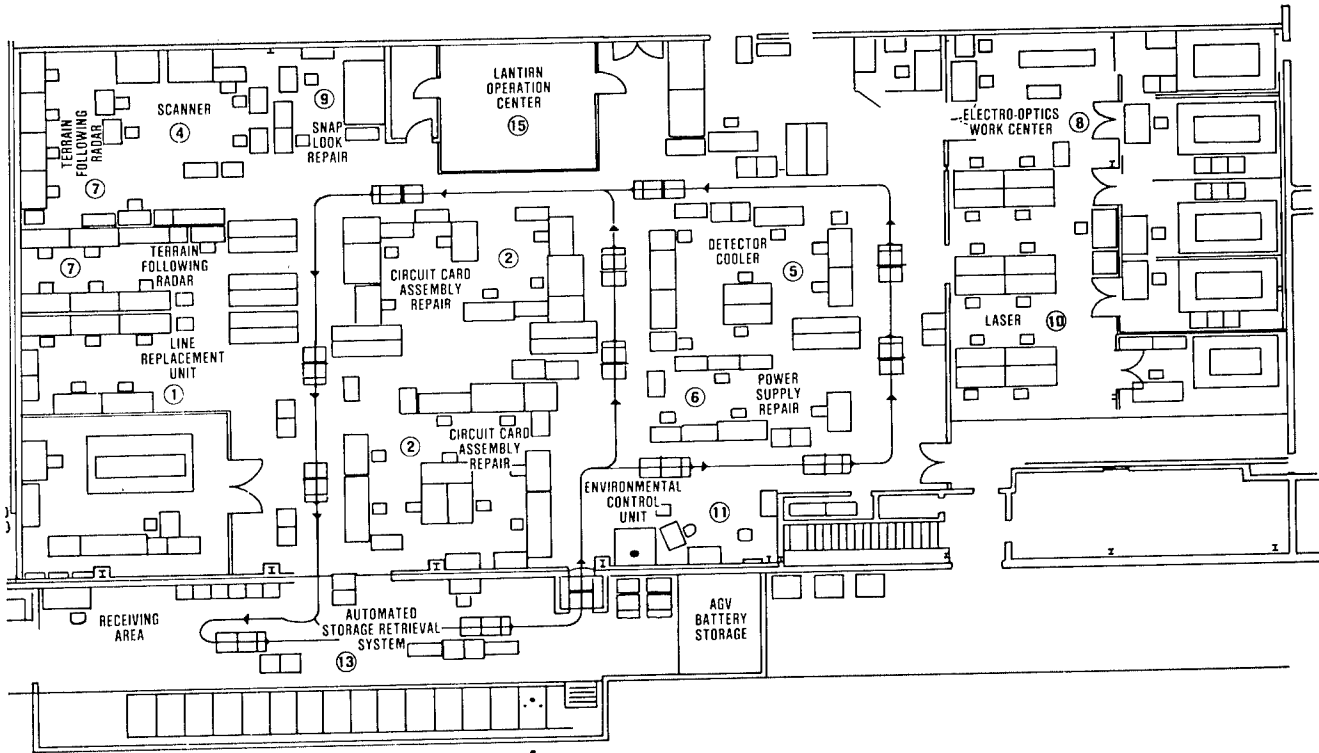

Figure 2.

hardware findings. The objective is to determine BIT/TPS effectiveness. If the BIT is identifying LRUs/SRUs as bad, when they are in fact not, an unnecessary repair action is initiated. The feedback made possible by actual hardware examination will promulgate the action necessary to recommend to the appropriate agencies the revisions that should be made to BIT. In a similar vein, if the TPS's component ambiguity call is too imprecise, causing good as well as failed components to be removed, appropriate updates to the TPS can be recommended. Also, the TPS structure can be reviewed to ensure the item most likely to have failed is called or tested first. This allows the appropriately revised TPS run times to be optimized to improve productivity.

The EPL also will be a critical component of LANTIRN's TQM program. By comparing UUT variability to UUT reliability, optimal normative targets can be identified. In turn, this will expand the repair process to require the components contributing to the increased variability span to be removed, in addition to those that failed. The result should be better UUT operability due to decreased UUT variability, which should contribute positively to LANTIRN system performance.

The digitized technical data that is integral to PLAD will have a number of unique capabilities. The technical data will, as today's data does, provide the individual with technical instructions; but it will do so in such a way that the job of ensuring technical compliance will be made much easier by leveraging computer technology. Several technical orders will be able to be viewed simultaneously because of the split screen capability, which is base-lined to the program. Page markers will be able to be placed in such a way that the recall of a particular portion or page of a technical order will be nearly effortless (Figure 4).

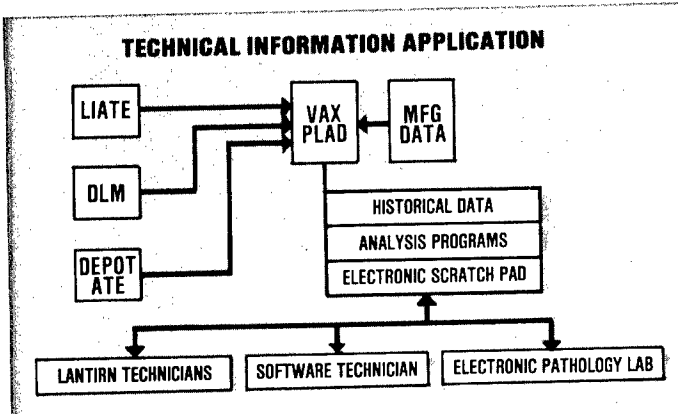

Figure 3.

Another unique feature of the CIR process is the Electronic Pathology Laboratory (EPL). As a part of the normal CIR/PLAD repair process, the EPL will store all failed components and, as dictated by circumstance, will examine the failed parts. The examination will determine if the parts identified by the TPS actually failed; if the failure was reasonable for the environment in which the component operated; why the component failed; whether the repair technique last employed contributed to the failure, indicating that either additional training and/or process improvement is in order; or if the failed component was one that the TPS should include as an item that contributed to a particular type of failure.

In addition to the EPL's gaining an understanding of the hardware aspects of the repair process, the software, in particular the BIT and TPS, will be examined based on these actual

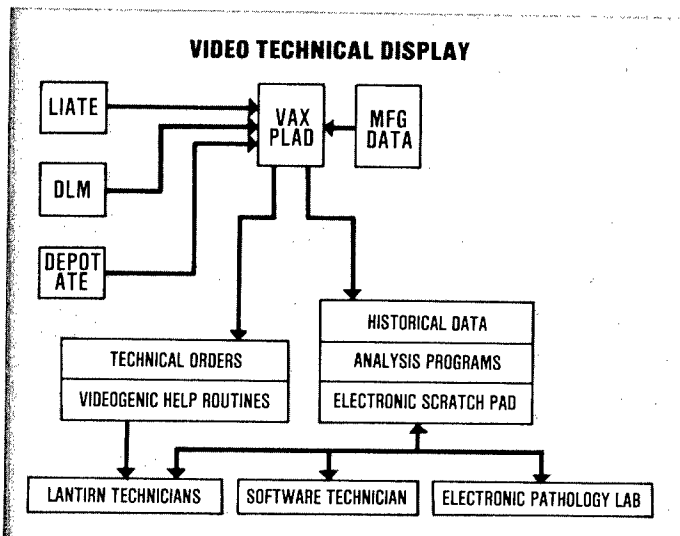

Figure 4.

Because every technician will work at a terminal location and because all the terminals are smart, all technicians will have their own set of depot technical orders, which include overhaul instructions, illustrated parts breakdowns, and general shop practices.

In addition to the notebook or scratch pad and other features described, a few other things have been incorporated into the PLAD/CBTO arena. With regard to work authorization, i.e., allowing only Production Acceptance Certified (PAC) personnel to accomplish work tasks, the program compares the person's qualifications to the job to be done. If the person is not qualified, the program will not proceed. Similarly, if any chemicals must be used, the program ensures that the task, site, individual, and work procedure are authorized. If a mismatch occurs, the program will not permit any chemically related action within its control to proceed.

Behind the screen, the CBTO will program the completion of a number of bureaucratic processes. As the technicians proceed through their technical data, touching the screen as each work process that appears on the screen is completed, the associated documentation, which today is completed in pen, pencil, or by employing a stamp, will be completed based on the touch screen work process inputs. In a similar manner, parts will be ordered by calling up the illustrated parts breakdown and touching the screen to indicate the component desired. Some additional questions will be answered, if necessary, to indicate quantity required, time desired, and delivery destination, if it is other than where technicians are creating their inputs. The program will advise technicians of the availability of the component and, if appropriate, will deliver it, if it is in the PLAD ASRS. If the part is not available, technicians will be advised; and, when the status is available, it will be provided to the technicians.

Another aid to technicians is the videogenic system which allows them to become familiar with a particular activity by viewing, on their terminal, a video presentation, which typically runs 20 to 120 seconds. The system was developed to aid technicians in the repair process. They can study complex assembly and disassembly actions and the correct and incorrect way of accomplishing a task. Also, they can learn more about recurring training which focuses on electrostatic discharge and how to deal with that phenomena, or which explains high value soldering techniques. Other special subjects may deal with test

station preventive maintenance or perhaps with the task certification process. As additional videogenic needs surface, the organic videogenic creation capability will be exercised to expand the repertoire of videogenic presentations. Based on the premise that a (static) picture is worth a thousand words, the videogenic moving picture should be worth much more. The use of this system should greatly enhance safety, productivity, and product quality.

The last major portion of PLAD is the Automated Materials Handling System (AMHS) (Figure 5). The primary purpose of the AMHS is to reduce the level of human involvement required to support repair production activities. The AMHS requirements were established based on a yearly production of approximately 137,000 hours with approximately 14,800 items being repaired (in a 10,000-square foot area) and with provisions made to address wartime production rates. They necessitated a 16-bay ASRS capable of containing 6,300 items with the largest being 108 pounds. Five automated guided vehicles will move materials from the ASRS to the requesting location. The items stored in the ASRS will include not only items to be repaired and their associated repair parts but also items required to support production activities, such as special tools, interface test adapters, fixtures, and any other item not available to technicians at their work station.

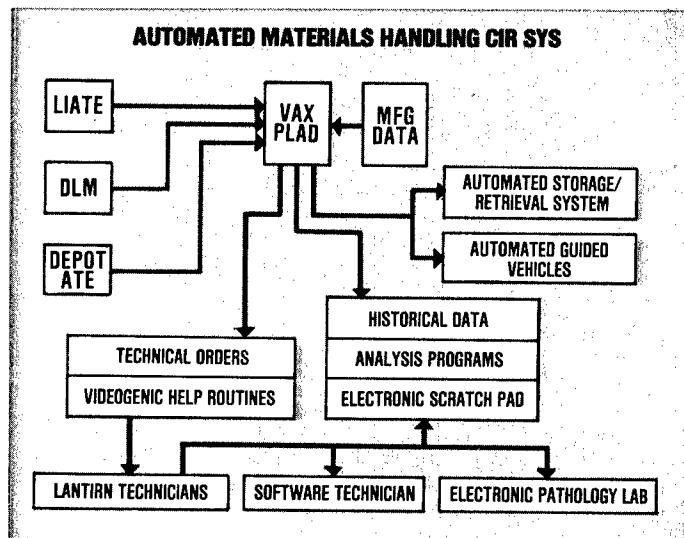

Figure 5.

Although it is not a primary objective that AMHS be included in the PLAD/CIR scheme, a significant reduction in bit-and-piece requirements is anticipated because: (1) visibility of the PLAD ASRS inventory will be available at all times, which will obviate the likelihood that someone will order something in error or excess, and (2) the consumption of each item will be recorded when it is consumed, which will aid planning personnel in determining consumable requirements. Also, the PLAD ASRS will be electronically linked to the others that are being installed in the Airborne Electronics Division. This will allow LANTIRN technicians to have visibility over all on-hand supplies in the division without leaving their work stations (Figure 6).

It is, of course, evident that the CIR process as represented by PLAD is a highly integrated software intensive hardware facilitated system. The CIR draws its power and benefits from the synergistic effect of combining in one software scheme all

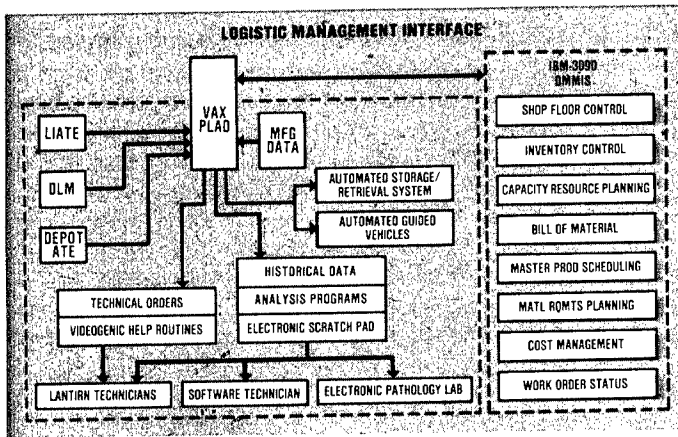

Figure 6.

the things a technician may need while eliminating the burdensome, denigrating, non-value added activities that today are typical in the workplace, in particular, the repair workplace.

PLAD offers many other opportunities and potential benefits. Because of its digital nature, it is easily integrated with any of the CALS or LMS initiatives. Due to the way the system was specified and designed, it is nonapplication specific. That is, the workload that it supports is transparent to the supporting software. This means that the newly established CIR process employed in PLAD also can be employed to support other weapon systems. And, in fact, this is the case. The CIR approach is planned to be employed to support the Joint STARS

and E-3 Radar Sensitivity Improvement Program (RSIP) when they become operational and are repaired by WR-ALC/MAI.

Again, because PLAD is an open approach, not only can it be used to support depot needs, but also can be, and PLAD is, designed to accommodate the needs or desires of field units such as those in the Tactical Air Command.

PLAD was designed not to burden the technician upon whom PLAD depends for the majority of the information that it uses. The likelihood of corrupted data entering the system is extremely small. The reliable nature of the information will allow other programs, such as Total Quality Management and bad actors, to meet their objectives and, in turn, improve the reliability of the systems they support.

Conclusion

Now that the first CIR application has been accomplished, the risk involved in employing this new concept is reduced considerably for other programs. Reductions, too, are expected in life-cycle cost because of the increased reliability, the personnel reduction afforded by AMHS, and higher productivity brought about by the availability of technical data and videogenics to facilitate the repair process at the work location.

CIR is certainly the next most likely evolutionary step in the depot-modernization process and is beyond doubt in concert with Computer Integrated Manufacturing (CIM). It is a highly integrated approach that leverages today's technology to benefit the repair domain in terms of higher productivity, potentially improved reliability, and enhanced product quality. Everyone who wants lower repair costs with potentially much higher levels of quality should make CIR their ultimate goal in the future.



AFLC Trims Inventory Through New Program

Air Force Logistics Command is trimming its supply of spare parts and other items in response to a Department of Defense plan to reduce the military's inventory.

AFLC, manager of the Air Force's \$62 billion inventory of equipment and supplies, has begun a reduction program called "PACER TRIM." The program follows DOD efforts to respond to changing national priorities and operate more efficiently as defense dollars become leaner.

"We need to be able to turn on a dime," said General Charles C. McDonald, AFLC commander. "With the changing force structure, reduced flying hours and base closures, AFLC's ability to reduce inventory growth, but maintain adequate levels of resources to support readiness, is vital to a smaller Air Force."

AFLC, which manages more than 900,000 items, will pare down both on-hand inventory and future budget requirements for defense materiel.

AFLC is using DOD's 10-point program for systematic inventory reduction as its guideline. The command's focus is on reducing or terminating contracts for spare parts and equipment no longer required as readiness needs change; designing more flexible contracts which can be adjusted as requirements change; and initiating aggressive disposal actions to clear warehouses of unserviceable inventory.

"A lot of responsibility will fall onto AFLC's item managers who oversee the requirements of the Air Force's vast inventory," said General McDonald. "Their job will be to aggressively check and double-check the necessity for an item, what its future use will be and how many are required to meet the Air Force's needs. Only through continued screening will future budget savings be realized."

The AFLC inventory reduction plan also incorporates Defense Management Report initiatives to streamline the procurement process and do business more efficiently. The report was announced by DOD in January 1990 in response to President Bush's request for acquisition reform.

AFLC News Release
29 August 1990

MRP II in AFLC Maintenance Planning and Control

W. Steven Demmy
Associate Professor of Management Science
Wright State University
Dayton, Ohio 45435

Anthony J. Giambrone
Assistant Deputy for Maintenance Systems
Logistics Management Systems Center
HQ AFLC, Wright-Patterson AFB, Ohio 45433-5000

The maintenance and repair of modern, high technology equipment is an important, complex, and expensive activity. In the Air Force Logistics Command (AFLC), over 37,000 people work in depot maintenance activities; and annual expenditures for materials, supplies, and other resources to support these efforts exceed \$2.5 billion. With the increasing complexity of modern weapons, the task of depot maintenance will not get easier. The challenge to logistics engineers of the 1990s will be to repair these complex systems with less people and smaller repair part budgets.

The Depot Maintenance Management Information System (DMMIS) is part of AFLC's answer to this challenge. DMMIS will improve AFLC's ability to forecast, plan, and control depot maintenance activities. It will use the latest information processing and requirements planning techniques. Significant reductions in inventory and lead times are expected. The reason for this optimism is that similar systems in industry have achieved spectacular results. The difference in AFLC's effort is that repair work is often hard to predict. This also means the bits and pieces needed for the repair operations and the frequency of some operations are far less predictable than in manufacturing.

To implement DMMIS, AFLC is adapting commercial Manufacturing Resources Planning (MRP II) software to deal with the complexities of the military repair environment. This article shows how MRP II can help in maintenance planning and explains how the Air Force is implementing MRP II capabilities. Finally, it describes some of the technical approaches the Air Force is using to adapt MRP II to repair operations.

Evolution of MRP II

In any manufacturing operation, we must have answers to a few basic questions: What are we going to make? What does it take to make it? What resources do we have now? What else do we have to get? (8)

For example, consider a decision to build little red wagons (Figure 1). We begin by calculating what we need and when we need it, and then manage according to this plan. Suppose we are to complete manufacture of 100 wagons on August 30. If we have no inventory, we must purchase or build 100 beds, 100 yokes, 100 tongues, 200 braces, 200 axles, and 400 wheels. Knowing the time needed for each manufacturing step, we can determine the required start and finish dates for each manufacturing and purchase order. This is done by working backwards from the desired completion date. If we have stock on hand or on order, the net requirement is less. It equals the total requirement less the available stock. For example, with 40 rear axle assemblies in inventory, only 60 more are needed to build 100 wagons. This reduces the requirements for braces, axles, and wheels. This process for calculating the time-phased net requirements for subassemblies and components is known as material requirements planning (MRP).

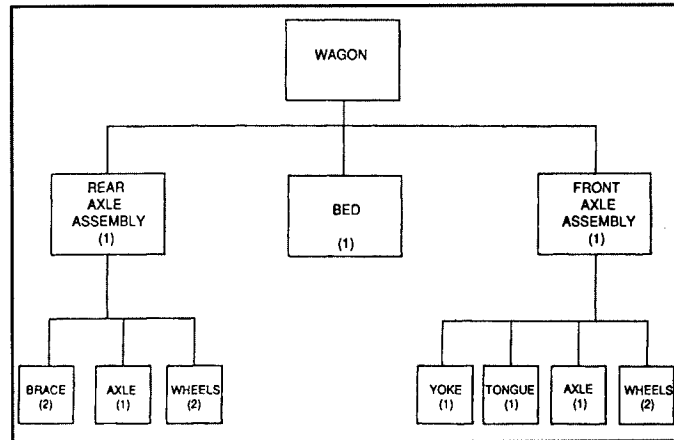

Figure 1. The product structure for little red wagons.

Basic MRP logic was probably used by Roman civil engineers and Venetian shipbuilders. It has been applied to millions of manufacturing and assembly operations. However, it was not until the late 1960s that the automation of detailed planning for mass production became a serious subject. Modern manufacturing involves large numbers of items, operations, and orders. Thus, answering the "what do we need and when do we need it?" question requires massive amounts of computation. In the early 1960s, third generation computers provided the required calculation power, and the movement toward automated material planning systems began. (5)

The early MRP systems provided important new capabilities, but they only solved a portion of the manufacturing planning problem. Thus, MRP pioneers often expanded their material management systems to include shop floor control and capacity planning functions. Beginning with a desired end item completion schedule, the basic MRP calculations yield the desired start and finish dates for each order. The needed start and finish dates for each operation of an order may be calculated from the MRP dates. The beauty of the MRP system is that, as unexpected changes are made to the end item schedule (changes due to lost parts, late delivery of supplies, sick workers, machine downtime, bad operations, or a myriad of other reasons), MRP can be used to revise the need dates for open orders. The revised need dates communicate updated priorities for order completion to the shop floor. Thus, one integrated computation can update both material plans and shop floor schedules.

Capacity requirements planning (CRP) is also a simple extension of the MRP logic. With a few more algorithms, we can compute the total labor and machine hours required to complete each operation for each open and planned order. By summarizing these calculations by work center and time period, we can obtain the total resources required to support all the scheduled outputs of the firm. The calculations required to compute the MRP, CRP, and shop floor schedules for thousands

of items are extensive and tedious. This is why a computer is a necessity. However, the basic idea is simple: Calculate what is needed and when it is needed. Then manage according to the plan.

By the early 1970s, scores of companies were either using MRP systems or starting implementation efforts. After MRP was working, many of these companies found it useful to integrate the new material and capacity planning systems with order entry, purchasing, shop floor control, accounting, and other major data systems. About 1980, the term "Manufacturing Resources Planning" was coined to denote the expanded scope of these enhanced MRP systems. Thus, the acronym MRP II was born. The initial intent of MRP II was to provide a system for planning and monitoring all the resources of a manufacturing firm. The idea was to include manufacturing, marketing, finance, and engineering in an integrated, closed-loop system which keeps all the planning and financial data of the firm. The closed-loop system compares the plans with the actual values and modifies future plans to achieve even better results. Another initial MRP II feature was a provision for the simulation of the manufacturing process. Today, MRP II is generally viewed as a total, company-wide system in which everyone works by the same game plan and uses the same numbers to manage the company. (3) MRP II integrates long-range, strategic decision making with the detailed systems required to accomplish these objectives. And it provides tools for quickly evaluating and modifying the detailed plans.

Components of Modern Planning Systems

Modern manufacturing planning and control systems have the major functions shown in Figure 2. (7) The demand planning function includes forecasting of end item and service part demand, consideration of interplant requirements, order entry, and order promising functions. In essence, demand planning coordinates all business activities that place demands on manufacturing capacity. Production planning defines the production rates that must be achieved to meet the company's strategic objectives. These production rates are usually established for each major product line or product family using monthly or quarterly planning intervals. Development of the production plan includes consideration of the capacity of the major resources required to accomplish production. Once agreed upon, the production plan becomes the primary framework for coordinating the activities of marketing, finance, manufacturing, and engineering, and for guiding further detailed planning.

The master production schedule (MPS) is the disaggregated version of the production plan. It is a statement of how many end items or product options, by part number, are to be completed in each future period. The MPS function often includes a rough cut capacity planning (RCCP) capability. RCCP provides quick evaluations of the effect of proposed changes in the master schedule upon the critical resources of the firm.

The MPS feeds directly into MRP. MRP determines period-by-period (time-phased) plans for all parts and raw materials needed for all the products in the MPS. This material plan then drives the detailed CRP calculations. The capacity plans compare the time-phased requirements for labor and machine resources with the planned availability of those resources.

The bottom portion of Figure 2 depicts the functions involved in the execution of the material and capacity plans. The shop floor control function establishes priorities for all shop orders at

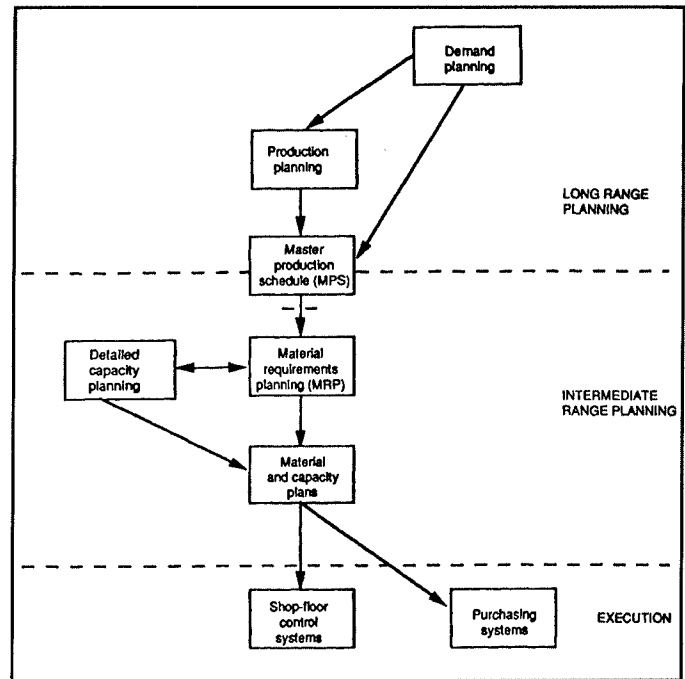

Figure 2. Major material planning and control functions.

each work center and tracks the progress of each order through the manufacturing process. The purchasing function provides detailed planning data for vendor scheduling and mechanisms for the release and monitoring of purchase orders.

Closed-loop operation is another key ingredient of modern material planning and control systems. At each step in the planning process, the feasibility of proposed material and capacity plans is evaluated. If planned capacity or available materials cannot support the proposed plans, then either the planned capacity or the material plans must be revised. Similarly, shop floor and purchasing activities are monitored to ensure orders are released and completed as planned, and that capacity is expended and used as planned. When actual production departs from the plan, then appropriate corrective actions must be taken and future plans must be revised. These feedback and adjustment activities keep the planning and execution activities consistent, feasible, and cost-effective.

The management of Air Force depot maintenance involves all the aforementioned functions plus a few others. These additional functions and unique features of the Air Force environment require modification from standard MRP II approaches. The next section discusses these differences.

AFLC Depot Maintenance

AFLC provides support to military forces around the world. Major activities include projecting material requirements; procuring supplies, repair parts, and equipment; and planning warehousing, distribution, and repair support. Over 50% of AFLC resources are used in depot maintenance. AFLC depot level maintenance is big business. It involves the work of over 37,000 people in six major industrial facilities. The industrial plant includes 536 buildings and investments in plant and equipment exceeding \$4.5 billion. Annual expenditures for labor, parts, and other required resources exceed \$2.5 billion. Each year, AFLC depot maintenance organizations overhaul or modify more than 1,200 aircraft and 6,400 aircraft engines or major engine components. In addition, over 1.1 million reparable assemblies, such as landing gears, radar sets,

navigation computers, hydraulic motors, and servomechanisms, are overhauled or repaired.

Figure 3 illustrates the major activities associated with the overhaul of a major equipment system; e.g., an F-16 landing gear. The process begins with the arrival of a reparable asset. First, the end item is disassembled into its components. Each of the components is then cleaned and subjected to possibly several processing and non-destructive inspection (NDI) operations. Each recovered component is potentially different from the one that preceded it. The evaluation and inspection (E&I) step identifies the precise operations required to return each of the recovered components to a serviceable condition. This is a major departure from the repetitive manufacturing environment where we always know how a part is to be built.

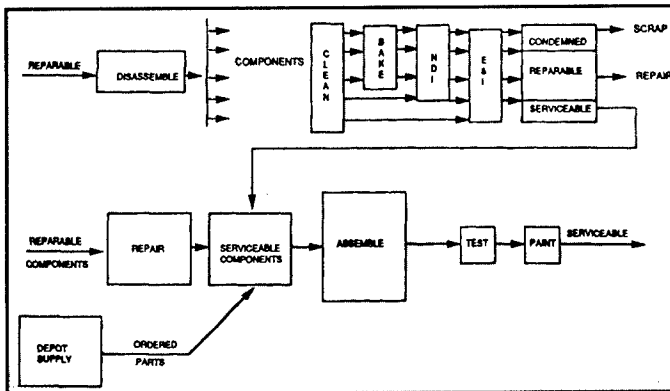

Figure 3. Typical disassembly and repair flows.

As we might expect, not all components are economically reparable. These are condemned at the E&I stage. Alternately, some of the components do not require any repair; these are transferred to serviceable inventories for use in reassembly. The remaining components are routed to the appropriate processing departments for repair. Repair may require more cleaning, disassembly, and inspection, as well as plating, machining, painting, or other industrial processes. When completed, the repaired components are moved to serviceable inventories. Finally, based on the need date of the serviceable end item, the required set of serviceable components is pulled from inventory. The end item is then reassembled, tested, painted, and shipped. For landing gear overhaul, reassembly is very similar to original equipment manufacturing.

Maintenance Versus Manufacturing

AFLC depot maintenance has many features similar to large-scale manufacturing. In both environments, efficient operations require advanced planning. Material requirements must be projected, purchased, and available in advance of need. Labor and equipment requirements must be planned and scheduled. Capacity is limited in both cases. In both environments, large numbers of orders must be scheduled and monitored, and plans must be adjusted to reflect unanticipated conditions. Finally, most of the functions and data elements required for manufacturing planning and control (bills of materials, routing files, inventory status information, work center capacities) are the same as those required for depot maintenance planning and control. On the other hand, maintenance has several features that are very different from manufacturing. In manufacturing, if there is not enough stock on hand, the required action is obvious: the needed items must either be purchased or built. In maintenance, however, repair

can often provide acceptable components at a small fraction of the cost of new items. Thus, repair of an unserviceable unit is often the best source of supply. For systems that are no longer in production, repair is often the only source of supply. As a result, over 90% of Air Force requirements for recoverable units are filled through repair.

Another significant difference between manufacturing and maintenance is the high level of uncertainty associated with repair. In manufacturing, every component of an end item must either be purchased or built. In depot maintenance, however, requirements for materials, labor, and capacity are often probabilistic. In maintenance, the exact amount of materials needed for a repair is often not known until the unit has been cleaned and inspected, and the failure mode has been identified. Similarly, the exact set of needed repair operations is often not known until other repair or inspection operations are done. Thus, planning of materials and capacity must be based upon averages and probability estimates. These estimates are then improved as inspection, diagnosis, and repair operations progress.

Figure 4 shows another source of uncertainty in repair planning. In maintenance, the same end item might be repaired in several different ways, depending upon the nature of the failure. Some failures may require the removal and replacement of components of the end item. Other failures may require disassembly of the end item into its components. In the latter case, the end item may lose its physical identity, the reverse of standard MRP manufacturing processes. Still other alternatives are: (1) no defect can be found in the end item, and the item needs no more work (the item "re-tests o.k."), or (2) the item cannot be economically repaired.

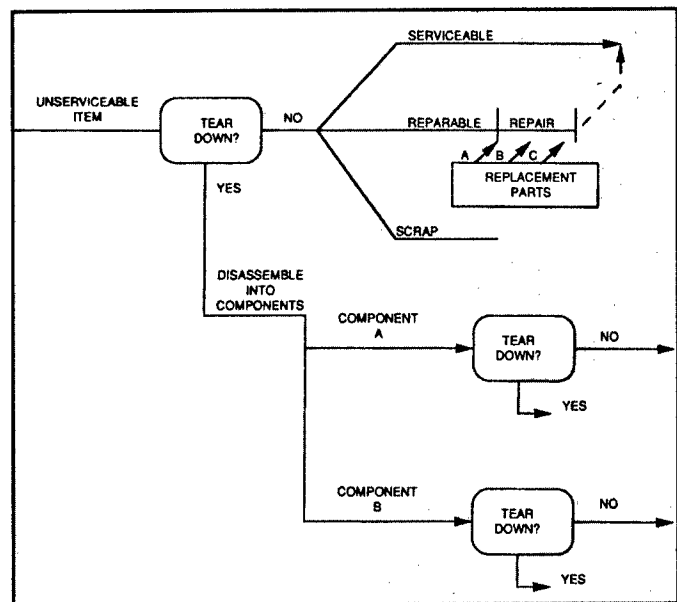

Figure 4. Alternate disassembly and repair flows.

The need for reparable cores is another source of planning uncertainty. A core is an unserviceable end item that may be returned to serviceable condition by repair. Air Force bases keep weapon systems operational by removing failed components and replacing them with a good unit from base supply. If the base maintenance shop cannot repair the failed item, the core is returned to the depot. If cores do not arrive at the predicted rate, the planned depot repairs cannot be accomplished. On the other hand, if core arrivals exceed predictions, there may not be

enough support materials or capacity to do the work. The prediction of core availability is based on past failures and anticipated usage rates of equipment in the field. For many hardware systems, the high variability of both usage and failures means that initial estimates of core availability are often wrong.

We have described some of the physical differences between depot maintenance and manufacturing. Several other differences exist because the Air Force mission and AFLC organization differ from commercial environments. For example, AFLC depot maintenance has one major supplier, the AFLC Directorate of Supply. All needed materials and repairable items are obtained through the Directorate of Supply using the Air Force's Stock Control and Distribution (SC&D) system. Also, AFLC depot maintenance has one major customer, the Directorate of Materiel Management (AFLC/MM). Within AFLC/MM, inventory management specialists use the Air Force's Requirements Data Bank (RDB) system to determine requirements for procurement and repair of recoverable items. They then negotiate with the Directorate of Maintenance and other military and commercial organizations for repair support. SC&D, RDB, and DMMIS all use relational databases and operate in an on-line transaction-oriented environment with information passed electronically among the different systems.

The Air Force depot maintenance mission is a final area that differs greatly from standard MRP II environments. The Directorate of Maintenance must be prepared to provide efficient, effective support for United States defense forces in a national emergency. During a war surge, lead time is critical; and demand rates and patterns may be significantly different from earlier estimates. Delays or errors may cost lives. Thus, the ability to adapt to changing conditions accurately and rapidly is particularly important.

We have deliberately emphasized the differences between AFLC depot maintenance and large-scale manufacturing. However, there are far more similarities than differences. Further, the differences that exist may be accounted for within the framework of the standard MRP II approach. Several large commercial organizations are currently using MRP II systems for managing major overhaul and repair operations. The Midland Workshop of the West Australian Government Railway is one of these organizations. (6) The Midland Workshop overhauls diesel locomotives and railcars; repairs and refurbishes freight and passenger rolling stock; manufactures wagons; and produces track, signaling, and communications equipment. Another MRP II user is the New Jersey Works of Morrison-Knudson. (1) The Morrison-Knudson system manages the overhaul and refurbishment of subway rolling stock. Other companies which use MRP II systems for managing large maintenance and repair operations include Pratt and Whitney, American Airlines, and Copeland Manufacturing.

DMMIS

DMMIS includes all the standard planning and control functions shown in Figure 2. However, DMMIS uses several modifications to compensate for the unique features of the Air Force environment (Figure 5). As already noted, the Directorate of Maintenance has one major customer, the Directorate of Materiel Management. This means that the demand planning and production planning functions illustrated in Figure 2 are very different from those in standard MRP II systems. AFLC/MM inventory management specialists use the RDB to estimate worldwide requirements for serviceable assets and the availability of repairable units. They then negotiate with

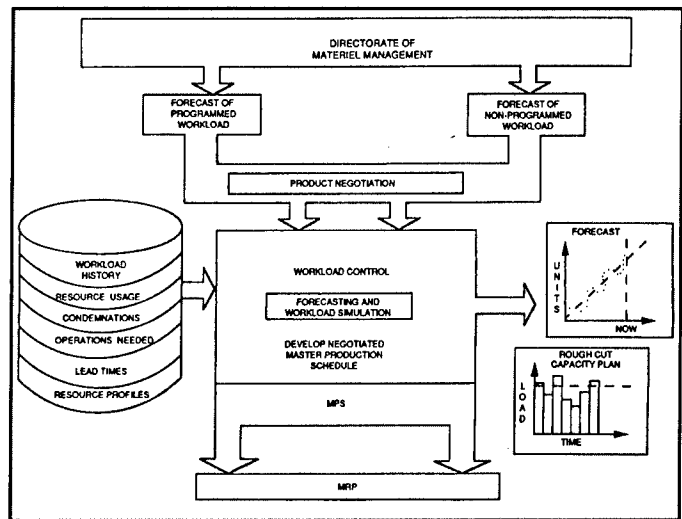

Figure 5. DMMIS functions: workloading and master scheduling.

commercial contractors and with the AFLC Directorate of Maintenance for the required levels of support.

Both programmed and nonprogrammed workloads are involved in these negotiations. Programmed workloads are reasonably predictable. For example, the work packages for aircraft overhaul and modification can largely be determined in advance; and the arrival dates of aircraft are carefully scheduled. Other programmed workloads such as repair of radar components and fire control units have greater variability, but still may be planned with reasonable accuracy. On the other hand, nonprogrammed workloads concern repair needs that are very difficult to forecast. For example, over a year's time, several aircraft may be involved in accidents or may receive battle damage. Nevertheless, materials must be available and capacity must be reserved to support these repairs. Thus, rough estimates must be used in planning resource requirements for nonprogrammed workloads.

DMMIS also includes an automated interface with the RDB. This interface will reduce the lead time needed to communicate Air Force worldwide requirements and will support quick and efficient negotiation of new or modified workloads. New forecasting tools will provide enhanced capabilities for analyzing trends and for estimating future needs. DMMIS also incorporates the capability to simulate the impact of new or modified workloads. This capability will use workload histories and resource profiles to evaluate the effect of proposed changes upon critical maintenance resources. Standard MRP II RCCP calculations will be used to implement the simulation capability.

Once workloads are negotiated and entered into the master production schedule, MRP and CRP computations are performed. In manufacturing, MRP calculates exactly what is needed, and when it is needed, to support the master schedule. In DMMIS, similar calculations are done; but because of the uncertainties of repair, the calculations are better described as estimates, rather than precise statements. Similarly, CRP provides estimates of the capacity and labor resources needed to support the planned workloads. By continuously updating and monitoring the material and capacity plans, potential problems may be identified and resolved before they become real problems (Figure 6).

Figure 7 shows the DMMIS execution modules. Many of the capabilities of these systems are identical to those used in standard manufacturing systems. The shop floor control module

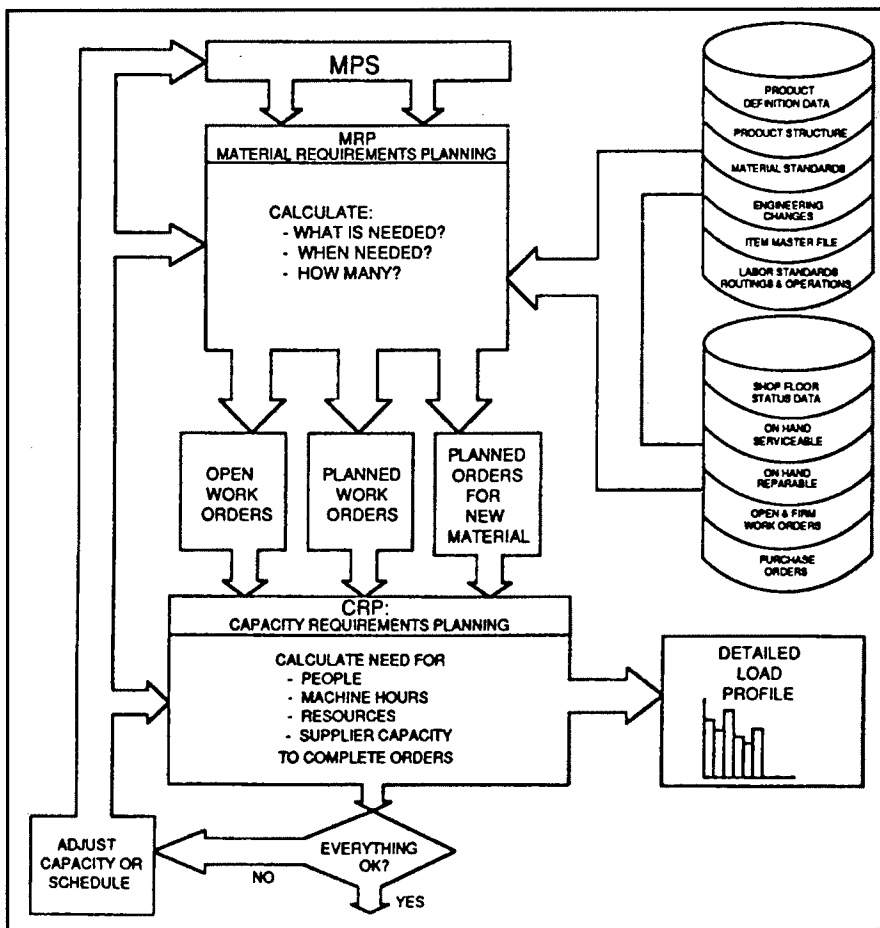

Figure 6. DMMIS functions: material and capacity planning.

will support the release and tracking of repair and assembly orders. It will provide up-to-date shop schedules and detailed short-range capacity requirements projections. It will also support cycle counting and inventory analysis functions. Bar-code capabilities will simplify reporting of order progress and reduce the possibility of errors. On-line terminals will provide status information for detailed planning and problem solving.

DMMIS also differs from standard MRP II systems in several major ways. As noted, each repairable unit may require a set of repair operations that differs from the unit that preceded it. As

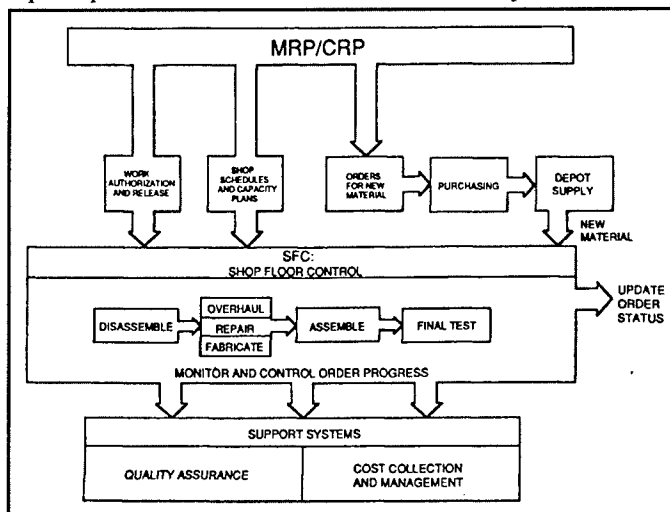

Figure 7. Shop floor control, purchasing, and support systems.

a result, the DMMIS modules support the easy construction of routings tailored to the unique needs of a given repairable unit. Planning and tracking of disassembly operations is another unique DMMIS feature. DMMIS also provides extensive data collection and analysis support for quality assurance, statistical process control, and reliability control functions as a by-product of its operation. In addition, the cost collection and analysis system will support the unique requirements of governmental accounting. Finally, the DMMIS purchasing module will automate the interface between depot maintenance and the Directorate of Supply through the SC&D system.

Summary

MRP II techniques have proven a powerful tool for improving the efficiency of large-scale manufacturing organizations. These techniques offer a similar potential for improving Air Force depot level maintenance. Although depot maintenance differs from manufacturing in several major ways, there are far more similarities than differences; and the differences that exist may be accommodated within the framework of standard MRP II concepts. We expect the use of MRP II techniques will result in major improvements in depot maintenance effectiveness. The benefits will include major decreases in repair times, overtime, and inventory levels. Control of work-in-process should be significantly improved. New capacity planning and forecasting capabilities should greatly assist workload negotiation, facility planning, and detailed shop scheduling.

We expect DMMIS to result in significant improvements in the cost-effectiveness of peacetime support of the Air Force. However, perhaps the major benefit of DMMIS is the potential to better support wartime operations. DMMIS will provide the tools to respond quickly and effectively to significant changes in demand rates and workloads. In peacetime, reduced weapon system repair times translate directly into additional operational aircraft. In a national emergency, reduced repair times translate into lives saved.

References

1. Bentley, David A., and Witt, R. L. "Applying MRP II to Remanufacturing: A Case Study," *1986 Conference Proceedings*, American Production and Inventory Control Society, October 20-24, 1986, pp. 18-21.
2. Boyer, John E. "How to Plan Material Requirements in a Remanufacturing Industry," *1987 Conference Proceedings*, American Production and Inventory Control Society, October 19-23, 1987, pp. 252-255 (not in text, but essential reading).
3. Chase, R. B., and Aqualano, N. J. *Production and Operations Management: A Life Cycle Approach*, Irwin, Homewood IL, 1988, p. 648.
4. Duncan, Robert M. "The By-Product Bill of Material," *1983 Conference Proceedings*, American Production and Inventory Control Society, pp. 288-292 (not in text, but essential reading).
5. Orlicky, Joseph. *Material Requirements Planning: The New Way of Life in Production and Inventory Management*, McGraw-Hill, New York, 1975.
6. Panisset, Brian D. "MRP II for Repair/Refurbish Industries," *Production and Inventory Management Journal*, Fourth Quarter, 1988, pp. 12-15.
7. Vollman, T. E., Berry, W. L., and Whybark, D. C. *Manufacturing Planning and Control Systems*, Richard D. Irwin, Inc., Homewood IL, 1988.
8. Wight, Oliver. *The Executive's Guide to Successful MRP II*, Oliver Wight Limited Publications, Williston VT, 1982, pp. 6, 17.



What's Wrong With This Picture?

General Creech and the TAG troops told us that, in maintenance, there were two types of work: (1) "real work" and (2) paperwork, supervision, and other functions that were traditionally thought of as overhead. Both types were necessary and important; but "real work," that which is done to airplanes and equipment, was most important because it was the direct labor that resulted in production (fixed equipment and generated sorties). If you have followed and believe the foregoing, then please look at Figure 1. It is called THE ENLISTED FORCE STRUCTURE and comes from AFR 39-6. I believe there is something wrong with this structure, and we loggies need to convince the personnel community (authors of 39-6) that this picture is somewhat out of balance.

In my opinion, most organizations need both categories of direct and overhead people; they are each indispensable elements of the team. I've also learned that one of the keys to getting the job done is to have the right ratio of direct-to-overhead people. Further, there is not one formula that applies to all organizations; a ratio of direct-to-overhead that works in one organization will not necessarily apply in another. Also, there are many forces of darkness that encourage, drive, and push people from the direct to the overhead world. Factors like more pay, air-conditioned offices, and symbols of status, such as vehicles and radios, all combine to lure direct workers away from the production environment. Finally, I believe that this direct versus overhead riddle has application in many worlds other than the traditional ones of smokestack industry and aircraft maintenance. There are direct workers in CBPOs, base supply, banks, Standard Systems Centers, all of Air Force logistics, and, arguably, even the Pentagon. The key to making an organization function is knowing the difference between direct and overhead work; how much of each kind needs to be done; who does it; and, most important, who should do it.

If you agree with these thoughts, then I'd like you to think that in Air Force logistics, the principal groups of people earmarked for direct labor are the enlisted force and their AFLC counterparts, the large number of civilians who work in the depot maintenance shops, directorates of supply, etc. However, I want to focus on Air Force enlisted personnel in the logistics business.

I believe that, while moving from airman to chief master sergeant, enlisted people will be involved in both direct and indirect work. I further believe that, like it or not, few if any of our logistics officers will ever be substantially involved in direct labor. If the aforementioned is given, then please look at Figure 1 again. The regulation (AFR 39-6) says that the purpose of this picture "is to define specific responsibilities of each enlisted grade." I calculated the numbers (in parentheses) to show the approximate ratio of each category of activity (trainee, worker, technician, etc.) to each grade in the enlisted force. As I read this chart, we expect 25% of technical sergeants to be technicians and 75% of them to be supervisors. Or, another view might be 25% of a technical sergeant's time will be in technical duties and 75% will be in supervision. Whichever case, it seems clear to me that this chart means that the principal activity of a technical sergeant should be supervision and the rest is technician time.

Looking at the rest of the chart shows how we expect the other grades to perform. If one adds the ratios for each category (trainee, technician) in Figure 1 and bar-charts them (Figure 2), one can see what I believe to be an imbalance problem. For example, in general terms, the picture of our Enlisted Force Structure indicates that for all enlisted grades, only four are to be "workers": airman - 20%, airman first class - 35%, senior airman - 60%, and sergeants - 50%. All this totals 165%. Similarly, four grades are involved as technicians for a total of 150%. The training category is the largest individual consumer of time at 285%. Having shown Figure 1 and given relative arithmetic weights to the various

SENIOR NONCOMMISSIONED OFFICER TIER ↑	CHIEF MASTER SERGEANT	LEADER (65)		MANAGER (35)
	SENIOR MASTER SERGEANT	(15) SUPVR	LEADER (50)	MANAGER (35)
	MASTER SERGEANT	(15) TECHN	SUPERVISOR (50)	MANAGER (35)

NONCOMMISSIONED OFFICER TIER ↑	TECHNICAL SERGEANT	(25) TECHNICIAN	SUPERVISOR (75)	
	STAFF SERGEANT	TECHNICIAN (75)		(25) SUPERVISOR
	SERGEANT	WORKER (50)	(35) TECHNICIAN	(15) SUPVR

AIRMAN TIER ↑	SENIOR AIRMAN	TRAINEE (40)	WORKER (60)	
	AIRMAN FIRST CLASS	TRAINEE (65)		WORKER (35)
	AIRMAN	TRAINEE (80)		(20) WORKER
	ENTRY	AIRMAN BASIC TRAINEE (100)		

Figure 1.

categories in Figure 2, I believe it fair to qualify some of the messages in these figures.

For example, I know that training and work go on at the same time—more than they should in my view—but, nonetheless, in the real world, trainees do in fact work. I believe it to be equally axiomatic that too often much of their work has to be done over—or should be. Second, I cannot draw a clear distinction between supervisor, manager, and leader. Finally, I suspect that Figure 1 was never intended to be a precise description of how much time/effort each grade should spend at each of those roles. Despite these qualifications, I still have a problem with this picture.

I think Figure 1 does represent a general mindset of how someone believes the enlisted force should function. If I am correct in that belief, then we in logistics should take serious issue with the author of Figure 1. One can argue the merits of trainees doing some work or managers occasionally being technicians. However, the irrefutable facts of the chart show that we expect the bulk of an enlisted person's time to be either as a trainee or in some form of overhead function like supervisor, manager, or leader. In my judgment, that is part of an evolving pattern of misguided thinking regarding the enlisted force. Misguided in that it overemphasizes professional development and too infrequently (if at all) gives corresponding credit and emphasis to the technical development of the enlisted force, thus enhancing their ability to perform their principal role: perform and direct our direct labor efforts.

Now, I suspect that the personnel folks (authors of Figure 1) will have a rebuttal for my argument. For example, they will quickly and correctly point out that I have omitted the population size in each category. Therefore, since the bulk of our enlisted force is in the first

or airman tier (airman basic through senior airman), we really do have more people in direct labor than the chart leads one to believe. I'll concede that point but dispute its relevance. The problem as I see it is simply this: Logistics needs a lot of direct labor. I don't know precisely how much, but the ratios indicated by Figure 1 are off the mark. Much more important, however, than just direct labor, we need skilled direct labor. If that is true, and you believe that NCOs represent higher forms of maturity, savvy, discipline, and technical skill (and I for one believe passionately that they do), then we should redraw this chart and all our thinking, testing, and promotions, and all measures of merit that derive from it, to put more emphasis on the worker and technician categories and less on the supervisor, manager, and leader.

I believe General Creech was correct. One of the key distinctions between the great outfit and the "also ran" is management's ability and courage to solve the riddle of direct labor versus overhead. Overhead is important. But in Air Force logistics, the emphasis should be on direct labor efforts. Direct labor is primarily related to workers and technicians and the more of them we have and the more skilled they are, the better the organization becomes. If you readers believe that, then we as a community should leave no stone unturned to convince the senior leadership that Figure 1 is a distorted picture and, most important, the philosophy that derives from Figure 1 is contrary to the lean and mean structure we envision for Air Force logistics in a future world of ever-decreasing resources.

Colonel Albert Schmidt
 Director of Supply Systems
 Hq Standard Systems Center
 Gunter AFB AL

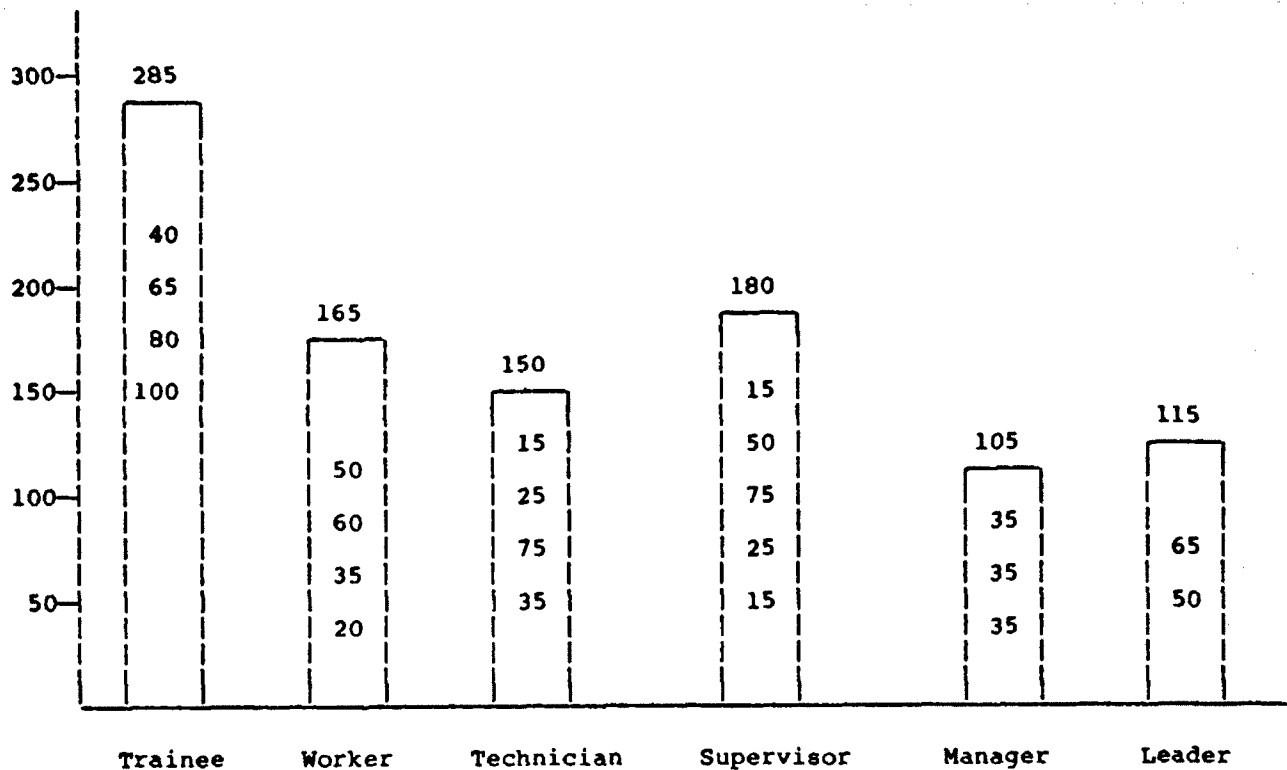

Figure 2.

Future Paint Stripping Techniques for Aircraft Corrosion

Captain Michael J. Then, USAF
Graduate School of Systems and Logistics
AFIT, Wright-Patterson AFB, Ohio 45433-5000

Lieutenant Commander Donald C. McNeeley, USN
Instructor of Logistics Management
School of Systems and Logistics
AFIT, Wright-Patterson AFB, Ohio 45433-5000

Background

The Air Force's single largest investment is the purchase of new aircraft. Unfortunately, funds for aircraft procurement will become scarcer in the future due to defense budget cuts and escalating aircraft costs. In order to maintain a strong defense capability, it is essential for us to develop economical programs to increase an aircraft's longevity. (10:7-8)

Structural durability and integrity are two of the primary factors affecting an airframe's longevity. The principal cause of decreased structural durability is corrosion, which weakens primary and secondary structural members, increases aircraft repair costs, and reduces the airframe's total life expectancy. (2:138-139) Maintenance facilities fight surface corrosion primarily through two means: periodic washing and protective painting. Routine washing reduces corrosion by removing grease and other impurities from the aircraft's surface that accelerate the process, while painting attempts to seal the airframe's surface from direct contact with harmful environmental effects. (2:138-139; 5:1-4) Though the primary purpose of paint is to protect the airframe from corrosion, it also provides camouflage and thermal protection. Because an aircraft must be repainted several times throughout its operational lifetime, proper paint removal becomes a critical initial step in assuring a quality re-paint program. (3:1)

Modern aircraft paint is extremely difficult to remove and has evolved much faster than corresponding paint removal processes. The most widely used paint removal process, chemical stripping, has become an extremely laborious procedure and is relatively primitive when used with many of the new paints. These modern paints require removal technology that relies heavily on toxic chemicals and hard physical labor. (3:1) This combination produces a hazardous work environment and can cause damage to the aircraft's surface when final stripping with sandpaper cuts through the paint layers and scratches the metal surface. (11:3; 1:1) Furthermore, chemical stripping was originally developed for metal aircraft which are not damaged by the chemicals themselves. Today's

newer aircraft structures are increasingly made of composites which may be damaged by the chemicals used in stripping. (11:3; 1:1) Because these chemicals constitute severe environmental hazards, the chemical stripping process is governed by extensive regulations covering handling, storage, transportation, and disposal.

Because of the environmental ramifications, we must find a replacement for the chemical stripping paint removal method. Work force health issues, cost escalation in hazardous waste disposal, and potential damage to composite surfaces make it clear a new paint removal method is needed. (14:22-25)

General Methodology

A Delphi questionnaire was used to solicit input from experts to obtain an objective technical forecast of future paint removal methods. (13:2; 8:20-21)

The Delphi Process

The Delphi method is an iterative opinion questionnaire technique using a group of experts, with anonymous feedback after each iteration, through which an optimal consensus is reached. This method was developed in the late 1940s at the Rand Corporation so experts could voice their opinions free of any dominant individual or majority opinion. (13:2) The process can be used to develop a technological forecast when a prediction of technical information is required. (4:142; 9:247-253)

Expert Selection

One of the first steps in performing a Delphi involves the expert group selection. A number of parameters can distinguish experts from nonexperts, such as educational level, professional training, experience, and specific skills pertinent to the Delphi study. (13:4-5) One general approach uses the perceived experts' reputations, recommendations by peers, and authors of published articles as selection parameters. The aircraft paint removal field includes individuals with many different technical degrees and related experience levels. It was virtually impossible to list all the desired experts' education and experience levels, because each aircraft paint removal method requires a different background. However, a 1988 Advanced Coatings Removal conference gathered over 200 corrosion control experts together, representing a variety of paint stripping technologies. The conference included technical representatives from the Department of Defense, Federal Aviation Administration, and civilian industries. It was conducted by 33 specialists who presented their latest paint removal innovations. (7:1-3) These 33 specialists represented a potential expert group needed for a successful Delphi. It was reasonably assumed that the 33 individuals were experienced in their particular paint removal field and had a broad enough technical education level to understand related paint removal topics. (12:193) These experts answered a series of first iteration questions which formed the second and third round survey



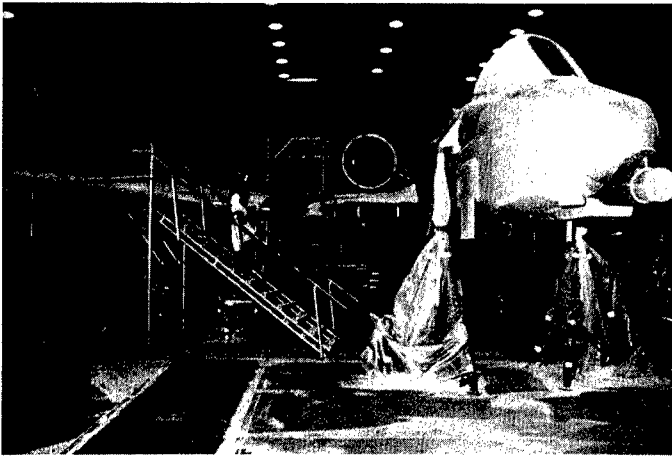

measurement questions. (6:22,200) Historically, one individual out of three contacted initially participates in such a research endeavor (9:211), but over 75% of the specialists participated in this Delphi process. Through three iterations, some interesting conclusions were obtained concerning the future of paint removal processes.

Results

Chemical Stripping. The experts predict that, in several years, plastic media blasting will replace chemical stripping as the predominant exterior airframe paint removal method. Chemical stripping will, however, continue to be used for some components, specifically those less than 18 cubic inches, those with an unusual shape, or those with special substrate composition. The primary reason for the demise of chemical stripping is today's increased emphasis on environmental hazards.

Plastic Media Blasting. Plastic media blasting was considered to be a fully developed stripping method, but the experts believe that additional process enhancement must be achieved through further research into the process's procedures and parameters. Though current plastic media blasting configurations can safely strip composite substrates under extremely controlled conditions with skilled operators, further research is necessary to reduce the variability of this process. Once plastic media blasting is a fully accepted methodology, it will continue to be used indefinitely for complete exterior airframe paint removal. The experts further stated it is unlikely that any other known paint removal method will become the predominant one in the next 15 years or more.

Regulations. Regardless of the paint removal method, future regulations will dictate the necessity for dedicated facilities to control handling, disposal, and air quality. These regulations will be the impetus behind the banning of chemical stripping within two to three years. It was unclear if environmental regulations will restrict facilities for plastic media blasting to the same degree as those for chemical stripping. While an alternative to current paint removal techniques might evolve because of possible strict regulations, impacting both chemical stripping and media blasting, the experts were unable to predict such a technique. Therefore, the major considerations for facility design are the environmental effects of paint stripping.

Laser Stripping. One possible alternative stripping method discussed by the experts which could be used for large components, such as rudders, wings, and exterior airframe surfaces, is laser stripping. However, the experts felt it is unlikely plastic media blasting will be replaced by laser stripping due to the method's high costs or unresolved technical

difficulties. Even if laser stripping could hurdle the economic/technical barriers, the experts were unable to predict when the process might replace plastic media blasting as the predominant exterior airframe paint removal method.

Robotics. It was felt robotic usage would soon be adopted for plastic media blasting, with this development taking place in three to four years. However, the plastic media blasting process and parameters must first be refined to optimize robotic effectiveness.

Working Environment. The experts stated that suitable protection was currently available for workers in the chemical stripping environment and that it was questionable if workers need to be forced from the chemical environment. For plastic media blasting, existing equipment adequately protects workers. In addition to protective equipment, the work environment can be further controlled using dedicated facilities designed for either plastic media blasting or laser stripping.

Recommendations

(1) Depots should fund for implementation of the plastic media blasting method to replace chemical stripping as the dominant paint removal method.

(2) Dedicated facilities must be developed to protect workers while handling, transporting, and storing by-products. Air quality standards must be maintained while using either plastic media blasting or chemical stripping.

(3) An economic evaluation should be conducted on the use of robotics with plastic media blasting and, if justified, robotic development should be funded.

(4) Research on paints should be continued to determine if any alternatives might provide simple, economic, and environmentally safe application and removal methods.



Conclusions

Since the Air Force today does not have the funding available to readily replace expensive aircraft, it must continue to refurbish the existing inventory through corrosion control and repainting. To accomplish this, the Air Force must have the ability to strip paint economically, safely, and with little or no environmental contamination. Through a Delphi technological forecast, state-of-the-art paint removal techniques have been identified and recommendations made concerning implementation of these new techniques. The preeminent forecast was that the plastic media bead (PMB) method would replace chemical stripping as the predominant paint removal method. Adoption of the PMB method must be funded now, and implementation plans should take into account the integration of robotic applications. While

research into other methods of paint removal should be maintained, the major emphasis will remain on improving the PMB process and especially the parameters associated with composite materials. Current paint stripping facilities should be evaluated for conversion to plastic media methods, and it is essential renovation contracts be properly funded. The Air Force must react now to the acknowledged demise of large-scale chemical stripping and plan for use of the PMB method.

(NOTE: Although some of the information in this article was collected in 1989, there have not been any recent technological advances to invalidate this data.)

References

1. Baum, B., et al. *Strippable Aircraft Primers and Coatings*, unpublished Technical Report AFWAL-TR-82-4073, Enfield CN, Springborn Laboratories Inc., June 1982.
2. Bent, Ralph D., and McKinley, James L. *Aircraft Maintenance and Repair*, New York: McGraw-Hill Inc., 1980.
3. Childer, Sidney, et al. *Evaluation of the Effects of a Plastic Bead Paint Removal Process on Properties of Aircraft Structural Materials*, unpublished Technical Report AFWAL-TR-85-4138, Wright-Patterson AFB OH, Materials Laboratory, December 1985 (AD-A165-289).
4. Claycombe, Wayne W., and Sullivan, William G. *Fundamentals of Forecasting*, Reston VA: Prentice Hall Company, 1977.
5. Department of Transportation, *Corrosion Control for Aircraft*, AC No: 43-4, Washington: Government Printing Office, November 1975.
6. Emory, C. William. *Business Research Methods* (Third Edition), Homewood IL, Richard D. Irwin Inc., 1985.
7. Ivey, Randall B. "Air Force Plastic Media Blasting Program Management And Status," *Proceedings of the DOD Tri-Service and Industry Advanced Coatings Conference*, Robins AFB GA, March 1988, pp. 1-3, 349-354.
8. Lanford, H. W. *Technological Forecasting Methodologies*, New York: American Management Association Inc., 1972.
9. Linstone, Harold A., and Turoff, Murray. *The Delphi Method - Techniques and Applications*, Reading MA: Addison Wesley Company, 1975.
10. Montgomery, W. R. "Combat Support Technology for the Twenty-First Century," *Air Force Journal of Logistics*, Vol XII, No 1 (Winter 1988).
11. Niedzielski, Peter J. *Laser Paint Removal System: Final Report*, unpublished Contract Report F-33615-87-C-5228, South Lyon MI, Laser Technologies Inc., August 1987.
12. Quade, Edward S. *Analysis for Public Decision*, New York: Elsevier Science Publishing Co., 1975.
13. Sackman, H. *Toward More Effective Use of Expert Opinion: Preliminary Investigation of Participatory Polling for Long-Range Planning*, Technical Report P-5570, Santa Monica CA: Rand Corporation, 1968 (AD-A040-885).
14. Vest, Gary D. "Air Force Concerns and Initiatives," *Proceedings of the DOD Tri-Service and Industry Advanced Coatings Conference*, pp. 18-27, Robins AFB GA, March 1988.

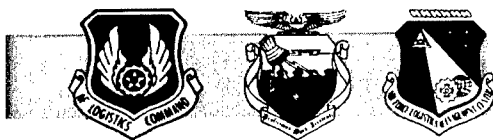

CURRENT RESEARCH

Air University Logistics Research at AWC - 1989-1990

The logistics related papers and projects completed by the students of Air War College during the 1989-1990 academic year are:

"General Support Division of the Air Force Stock Fund: What Are the Problems and Proposed Solutions?"—Col Robert K. Rasmussen (**Winner Society of Logistics Engineers (SOLE) Award**).

"Contractor Logistics Support for the Tactical Air Forces: Can It Be Made Affordable?"—Lt Col Jan D. Edeburn (**First Runner-up Society of Logistics Engineers (SOLE) Award**).

"Strategic Mobility—Is Emphasis Still Needed?"—Lt Col John W. Dalton and Lt Col Larry G. Radov (**Second Runner-up Society of Logistics Engineers (SOLE) Award**).

"Air Force Acquisition Stability and the Program Manager"—Lt Col John L. Clay (**Second Runner-up AWC Excellence Award**).

"Total Quality Management, Reliability, and Maintainability: Institutional Goals with Built-in Barriers"—Lt Col Philip B. Aitken-Cade.

"Improving Technology Insertion in Existing Air Force Weapon Systems Through the AFLC Modification Process"—Mr Roger M. Ashley.

"Streamlining the DOD Acquisition Process—One More Time"—Ms Lori J. Brady.

"The Impact of Terrorism on Air Force Logistics Command's Overseas Activities"—Lt Col Timothy P. Callahan and Lt Col Robert N. Mitchell.

"Leadership: The Key to Successful Implementation of Total Quality Management"—Lt Col Ronald E. Channell.

"Cheyenne Mountain System Acquisitions: Problems and Principles"—Lt Col Ellis K. Conoley.

"Regional Corrosion Control Facilities"—Col Raymond W. Davies.

"Total Quality Management: Performance Standards for Today's Information Managers"—Lt Col Bernard E. Dee, Jr.

"Total Quality Management: Will It Work in the System Program Office?"—Col Gary L. Delaney and Lt Col Michael J. Prowse.

"Operational Logistics"—Lt Col John P. Di Pierro and Lt Col Ronald G. Summerlin, USA.

"Privatization of Aircraft Maintenance: Maximizing Contract Effectiveness"—Lt Col Mary B. Hamlin.

"How Does the Air Force Create Effective Accountability for Initial Spares?"—Ms Pamela J. Henson.

"Off-Board Expendables: An Aid to Aircraft Survivability"—Lt Col Jeffrey N. Knieriemen.

"The Pacific Distribution System"—Lt Col David C. McClure.

"A Cost Savings Analysis of the Streamlined Military Construction Program Process"—Lt Col Thomas W. Olmstead.

"Will Market Analysis Increase Utilization of Air Force Dining Facilities via Improved Customer Service?"—Lt Col Hedy C. Pinkerton.

"Management of Depot Level Aircraft Maintenance and Overhaul Programs in the Defense Logistics Agency"—Col James B. Smith, USA.

"Historic Applications and Potential Future Uses of Engineering and Installation Communication Repair Assets During Wars, Contingencies, and Crises"—Lt Col Robert E. Witmer, ANG.

"Technology and the Evolution of the Strategic Air Command and the Air Force Space Command"—Lt Col George M. Xiques, Jr.

Loan copies are available through the Air University Library, Interlibrary Loan Service (AUL/LDEX), Maxwell AFB, Alabama 36112-5564.

Distribution Priority System: Time for a Change?

Major Donald E. Hamblin, USAF
Chief, Operations Support Branch
96th Supply Squadron
Dyess AFB, Texas 79607-5000

The present logistics system can meet neither peacetime nor wartime needs for repairing and distributing spare parts to keep the airplanes flying. RAND identified this deficiency in a study, *Project Uncertainty*, which concluded that changes in the present logistics system could make the Air Force more sensitive to the needs of the fighting force. (15:13) Distribution priority is a key element within the traditional logistics structure that can make these changes materialize in the operational world.

In 1986 the Air Force Logistics Command (AFLC) developed plans to change its system of operations. The existing system was extremely stable but not very flexible, nor was it responsive to dynamic changes in the operational community. The new concept of operations will allow the logistics system to respond more rapidly and be more flexible to operational needs. (4:1) The process that makes this change feasible is called Distribution and Repair In Variable Environments (DRIVE). Developed by the RAND Corporation, DRIVE focuses on short notice changes in the operational community and shifts resources (dollars, test equipment, spare parts, workload) to meet them. Using information systems and computer technology, it prioritizes these resources for one purpose—to improve combat capability. DRIVE uses criteria like airplane importance (aircraft availability goals), base importance, and the flying program at the base. All of this simply means that DRIVE will prioritize resources based on operational priorities and that, at any given time, some airplanes will be more important than others. (13:39)

In December 1988, AFLC developed detailed plans to use DRIVE in the depots for forecasting and repairing spare parts. (7:2-13) The next logical step will be to distribute spare parts to the operating commands using the same process. DRIVE will exploit the characteristics of speed, range, and flexibility. Unfortunately, many of the operating commands are skeptical this can actually happen. (11) This is understandable for a couple of reasons. First, RAND, AFLC, and Tactical Air Command (TAC) are the only ones who have been testing this process. Second, prior studies have addressed general AFLC logistics structure concepts but have never demonstrated whether a new distribution priority system is feasible or could be implemented. (4:26) For example, what will the priority system be based on and how will it work? This information is essential if the Air Force is to successfully implement a distribution process that is simple, flexible, and responsive.

The purpose of this study is to show that a new distribution priority system is feasible and can be implemented. To do this, we will analyze and critique the driving forces behind the current distribution system—DOD Military Standard Requisitioning and Issue Procedures (MILSTRIP) and the Uniform Materiel Movement and Issue Priority System (UMMIPS)—and compare it to DRIVE. We will then highlight other priority systems that could be modified and develop a hybrid priority system that is operationally oriented.

Simply stated, MILSTRIP is no more than a requisitioning and issue system using forms, codes, and rules which are

common to all the military wholesale (depot) and retail (base) logistics services as well as the Defense Logistics Agency (DLA) and the General Services Administration (GSA). It is not intended to be used for anything else. (3:12) It is not a financial accounting system, an inventory control system, or a system of priorities, although the established standard priority system, UMMIPS, is fundamental to the operation of MILSTRIP. Both systems provide a uniform set of procedures for requisitioning and issuing materiel within *standardized* priorities. Before MILSTRIP was implemented, the Air Force supply system used 16 priorities, the Navy 37, the Army 10, and the Marine Corps 2. (17:1-3) To eliminate confusion, DOD established UMMIPS in 1961 in conjunction with MILSTRIP. (3)

UMMIPS uses priority designators based on a combination of factors that relate the requisitioner's mission (force/activity designator - FAD) to urgency of need or end use (urgency of need designator - UND). The FAD, a Roman numeral, is established by the Secretary of Defense, the Joint Chiefs of Staff, or by each DOD component; the UND, an alphabetical letter, is determined by the requisitioning activity. (9:11)

The FAD, which can be I through V, is determined on the basis of defense importance or mission essentiality. The UND for the items is not considered in assigning this designator. The Air Force formally reviews precedence rating assignments through the Priority Review Working Group (PRWG) annually. The USAF Program Installation Units and Priorities Program Document (PD) is the only official Air Force document listing approved precedence ratings. When operational units requisition supplies, they use UMMIPS priority codes based upon a combination of the FAD, precedence ratings, and the UND. These priority codes range from 01 (the highest priority given to FAD I units with UND A—cannot perform mission (MICAP)) down to 15 (the lowest priority assigned to FAD V units with UND C—routine stock replenishment). UMMIPS priority codes provide a relative priority and dictate where spare parts are to be distributed. Also, the priority codes are combined into three issue priority groups as shown in Figure 1. (6) In the first two of these issue priority groups, the priority sequence (Figure 2) is used in distributing spare parts that are in short supply.

MILSTRIP advocates support this standardized process because it enables any requisitioner in the Army, Air Force, Navy, and Marine Corps to obtain parts from any source of supply (depot, DLA, GSA). They think this priority system is simple and responsive. (3:13) It may be simple, but it is neither responsive nor flexible. MILSTRIP's definition of responsive—to react quickly—leaves a great deal to be desired. There is no doubt that quick response is extremely important when distributing spare parts to our customers. The problem is, it is "blind" response. It does not assess the *quality* or the merit of the response. A *quality* response would be distributing a part to a location that will give us the best return for our money (improving airplane combat capability). The current priority

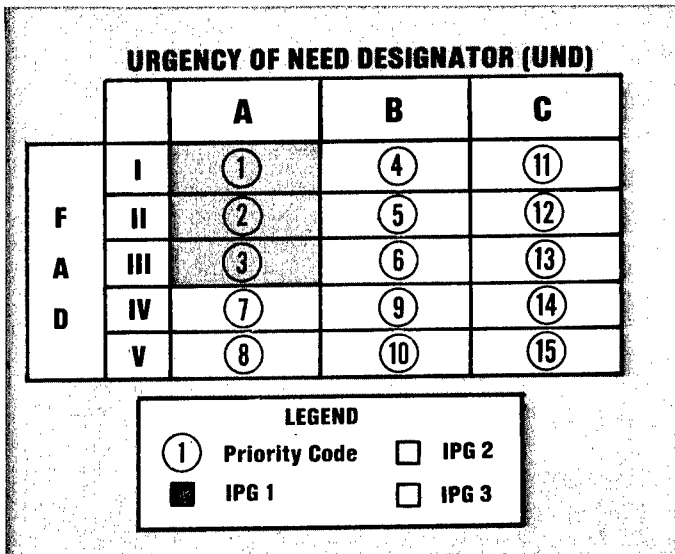

Figure 1. FAD/UND conversion into priority codes and issue priority groups. (15:131)

scheme does not do this. Except for extraordinary circumstances, the system only responds within a "window" of predetermined priorities. For example, the item manager may override a requisition to support a higher priority need based only on criteria in Figure 2. It does not "bend" to the needs of the warfighting units.

The principal deficiency of this system is that it focuses on the wrong objective. This system was developed to respond to the dictated needs of the customer (within predetermined priority groups) instead of the combat needs of our warfighting units. Resources are not explicitly linked to operational needs (strategic airlift, air refueling, counter air, air interdiction, close air support), and requisitions have no particular relevance to a specific aircraft, unit, or operational command mission or

aircraft availability objectives. In essence, this priority scheme does not prioritize distribution of spare parts based on the relative *wartime contribution* of each operation. (10:121-123) Instead, "the actual sequence seeks an equitable balance between high and low priority needs across all FADs." (15:130)

This is not the best approach to satisfying customers' demands. A more straightforward approach would be to let computer technology help the distribution system (wholesale or retail) "decide" where spare parts should go. Through a series of computer algorithms, it would determine which base would get the most benefit from the spare parts (improved airplane combat capability). This approach is called DRIVE.

DRIVE is not a computer system. It is a model imbedded in a computer system that prioritizes repair and distribution actions for the depot with the goal of improving *airplane combat capability*. The model determines which items should be repaired and distributed first. It does this by looking at the resources (amount of time, dollars, materials, and test equipment) that are available for use. In essence, it computes how we can get the "biggest bang for the buck."

Although unique in its application, DRIVE uses techniques found in assessment and spares computation models. DRIVE uses Dyna-METRIC-like assessment techniques when making decisions, and Dyna-METRIC assessments have been used as a standard tool since 1982. (14:9) The model simulates how spare parts flow from the flight line through the supply and depot maintenance structure and back to the flight line. (8:1) Through an information system called Weapon System Management Information System (WSMIS), assessments are usually conducted on a weekly basis (but can be done daily) to inform wing commanders, operating commands, and depots how ready we are to go to war (combat readiness) and how long we can keep supporting our customers during war (combat sustainability). Assessments also let us know how poorly we are

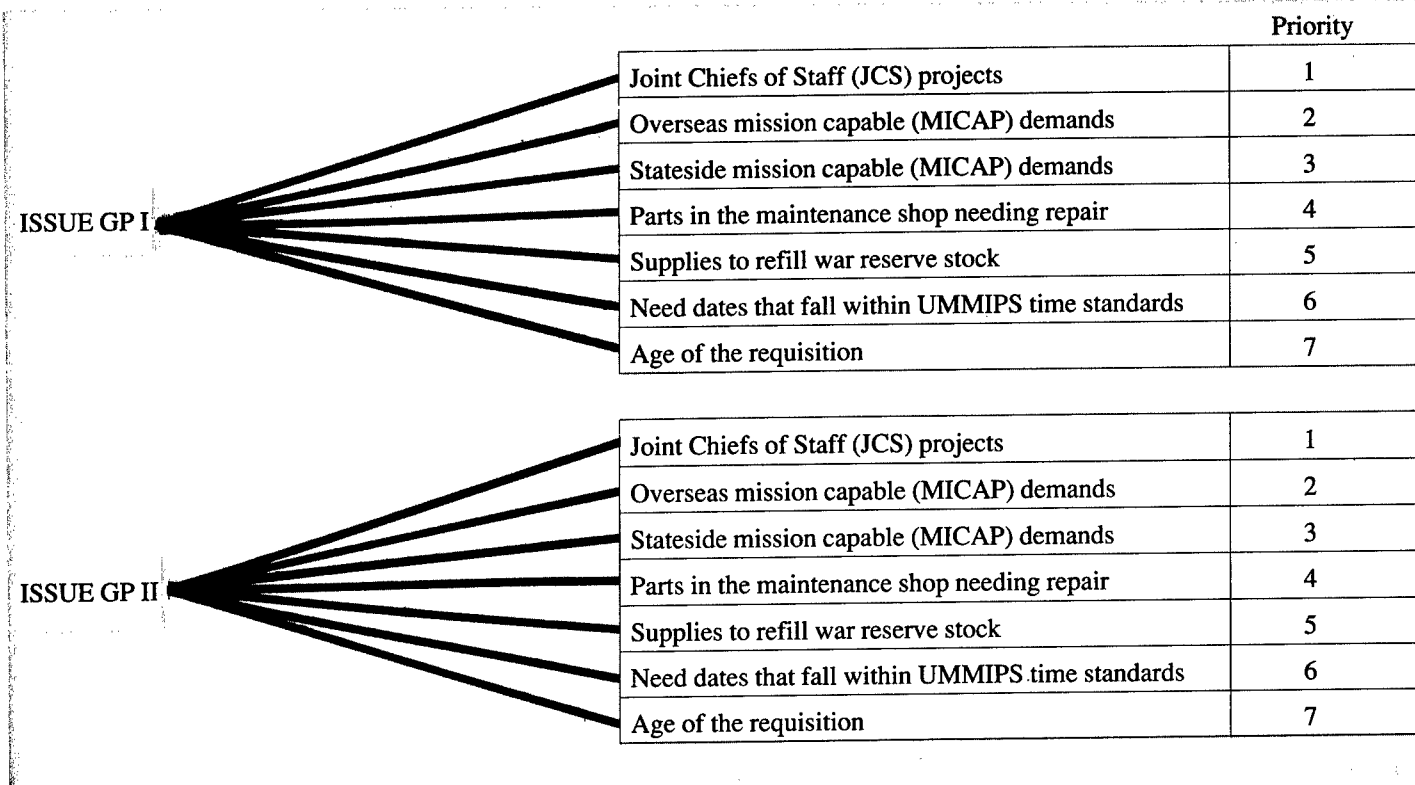

Figure 2. Distribution priority sequence for assets in short supply. (HQ AFLC/MMI Briefing, 1989)

performing logistically and what we can do to correct the problems.

A key element of DRIVE is that it measures the impact on *aircraft availability* when making its decisions. An available aircraft is one that is ready to fly and not waiting for a spare part. (12:36) Dyna-METRIC assessments use *aircraft availability goals* when rating operating commands on their combat capability. DRIVE uses *aircraft availability goals* to identify and rank those spare parts that provide the best chances to improve capability. (4:14) These goals represent a key element in determining where a spare part is to be distributed. The goals need to be meaningful because they represent the importance of the weapon system. When operating commands identify goals for weapon systems, the depots rank each spare part in relation to the weapon system. This provides the basis for a flexible priority system that allows the depot to distribute parts in priority sequence down to unit level. (16:23-29)

Although AFLC is developing a flexible and responsive computer system that will prioritize spare parts based on combat capability, the Air Force has not yet developed a *distribution* priority system to facilitate this process. All we have is UMMIPS and MILSTRIP, which cause the depots to respond to priorities that have no direct link to combat capability. However, the status of resources and training system (SORTS) and the operational priorities system for wartime supplies do consider combat capability; and they can be modified so spare parts can be distributed under the same criteria. These priority systems focus on the operational needs of the combat forces and, when coupled with DRIVE, will improve combat capability.

SORTS is a DOD concept that measures a unit's combat capability by looking at the level and condition of its supplies and level of training. This information is transmitted through the Worldwide Military Command and Control System (WWMCCS) and is used by the National Military Command System in conducting joint planning and operations in both peacetime and wartime. (1:97)

SORTS is a method used to measure aircraft combat capability and combat readiness. Each military service's mission is reflected in its operational capability plan. This plan determines the unit's logistical warfighting capability (what supplies are required and available in stock). Based on this plan, each service uses SORTS to report, to the Joint Chiefs of Staff (JCS), its ability to meet a wartime mission. SORTS, which contains basic information on combat readiness, is used by wing commanders, commanders of unified and specified commands, service major commands, and service component commands. (1:96) It uses unit category levels (C-1 through C-4) to assess a squadron's ability to meet its wartime mission; that is, SORTS determines how many missions the squadron can fly (sortie generation capability) or how many aircraft it will have available to support the theater commander's needs (strategic air, close air support, air interdiction, counter air). SORTS also determines how long the squadron can support its mission by checking the types and quantities of spare parts it has or will have in stock. The calculation basically involves judging the availability of

selected supplies to support the unit within its operational response time (Figure 3). It determines how quickly the unit can respond, how many sorties the unit can fly, and the duration of those sorties. Each mission is identified in terms of sorties or available aircraft translated into a measure of combat capability. (2)

The Air Force uses WSMIS to compute C-levels for supplies. Given a particular aircraft availability goal, this system can tell the theater commander what kinds of resources are needed to meet the mission. Furthermore, WSMIS can help the theater commander determine which squadrons are combat ready and where the unit's resources need to go to improve combat capability. Finally, since aircraft availability or sortie goals represent a mission's priority, the theater commander can direct where supplies should be distributed.

The operational priorities system for wartime supplies was developed by an Air Force Operational - Logistics Working Group to solve the deficiencies in the way Air Force bought its wartime supplies. Basically, the operations and logistics communities planned, managed, and performed their functions using separate guidelines. The operational community used factors such as war mobilization and operations plans to fly its mission while the logistics community used UMMIPS criteria, logistics priority indicators, and balanced funding techniques—"something for everyone" to support the mission. The Air Force realized that to win the war, the logistics community must support the operational community. The operational priorities system for wartime supplies accomplishes this by using operational criteria for both the logistics and operational communities. This enables the logistics community to respond to the actual needs of the operational units. (5)

The operational priorities scheme uses C-levels and aircraft availability assessments. It also considers various operational regional plans that have been developed to support contingencies across the world. (5) Unlike UMMIPS and MILSTRIP, the operational priorities scheme uses a combination of prioritized force and regional designators to focus on those combat assessments previously shown in Figure 3. The operational priorities scheme is shown in Figure 4.

Inplace forces refers to those forces already deployed overseas. *Deterrent forces* refers to those forces that provide worldwide deterrence; they must deploy and be in place early. *Warfighting forces* can be defined as those that are credible reserve forces. *Support forces* provide support to combat forces. *Attrition fillers* refers to forces used to backfill combat losses.

The type force designators are determined by mission importance much like the FAD designators used in UMMIPS, but all resemblance stops there. Included with the type force designator is a region priority that identifies those areas supported by the unified and specified commands. Combining these priority codes with combat sortie or aircraft availability criteria establishes the relative importance of different missions, regions, and airplanes.

Although one can never be sure of what kind of conflict to buy spare parts for, this concept provides the military with the

COMBAT LEVELS	ACFT LEVELS	SORTIES	SPARES ASSESSMENT
C-1	63-100%	95-100%	100%
C-2	50-62%	87-94%	89%
C-3	42-49%	80-86%	79%
C-4	0-41%	0-79%	64%

Figure 3. C-level criteria.

TYPE FORCE

- 1 - STRATEGIC DEFENSE
- 2 - INPLACE
- 3 - DETERRENT
- 4 - WARFIGHTING
- 5 - SUPPORT
- 6 - ATTRITION FILLERS

UNIFIED/SPECIFIED COMMAND REGIONS

- 1 - NORTH AMERICAN AEROSPACE DEFENSE COMMAND (NORAD)
- 2 - EUROPEAN COMMAND (EUCOM)
- 3 - ATLANTIC COMMAND (LANTCOM)
- 4 - PACIFIC COMMAND (PACOM)
- 5 - CENTRAL COMMAND (CENTCOM)
- 6 - ALASKA
- 7 - SOUTHERN COMMAND (SOUTHCOM)
- 8 - TRANSPORTATION COMMAND (TRANSCOM)

Figure 4. Priority codes for wartime supplies.

flexibility to allocate resources based on availability goals, regional priorities, and c ratings. It is a flexible yet simple tool the Air Force can use to buy wartime supplies. Both the operational community and logistics community on the Air Staff think this scheme is logistically feasible and that it adequately differentiates between combat forces. (5)

SORTS and the operational priority system for wartime supplies can be used to develop a new priority system that will distribute spare parts based on operational requirements. It should use the existing FADs because these designators represent the priorities of the JCS. However, instead of relying on a priority structure that is static and rigid, and that distributes parts as dictated by the requisition, we should be relying on a priority structure that is mobile and fluid, and that distributes parts as dictated by improvements in combat capability. Figures 5, 6, and 7 represent such a system.

combat capability objectives, we can get the right parts to the right airplanes at the right times. This priority structure is also flexible, because detailed aircraft availability goals and regional differences allow the depot to respond quickly to any part of the

FORCE ACTIVITY DESIGNATOR	REGION
I - COMBAT OR DESIGNATED BY SECRETARY OF DEFENSE	1-NORAD
II - COMBAT/FORWARD DEPLOYED (D+1)	2-EUCOM
III - DEPLOY READINESS (D+30)	3-LANTCOM
IV - ACTIVE & RESERVE (D+30)	4-PACOM
V - REAR ECHELON	5-CENTCOM
	6-ALASKA
	7-SOUTHCOM
	8-TRANSCOM

Figure 5. Distribution priority codes.

COMBAT LEVELS	AIRCRAFT AVAILABILITY GOALS	SPARES ASSESSMENT
C-1	63-100%	100%
C-2	50-62%	89%
C-3	42-49%	79%
C-4	0-41%	64%

Figure 6. Distribution combat capability spares matrix.

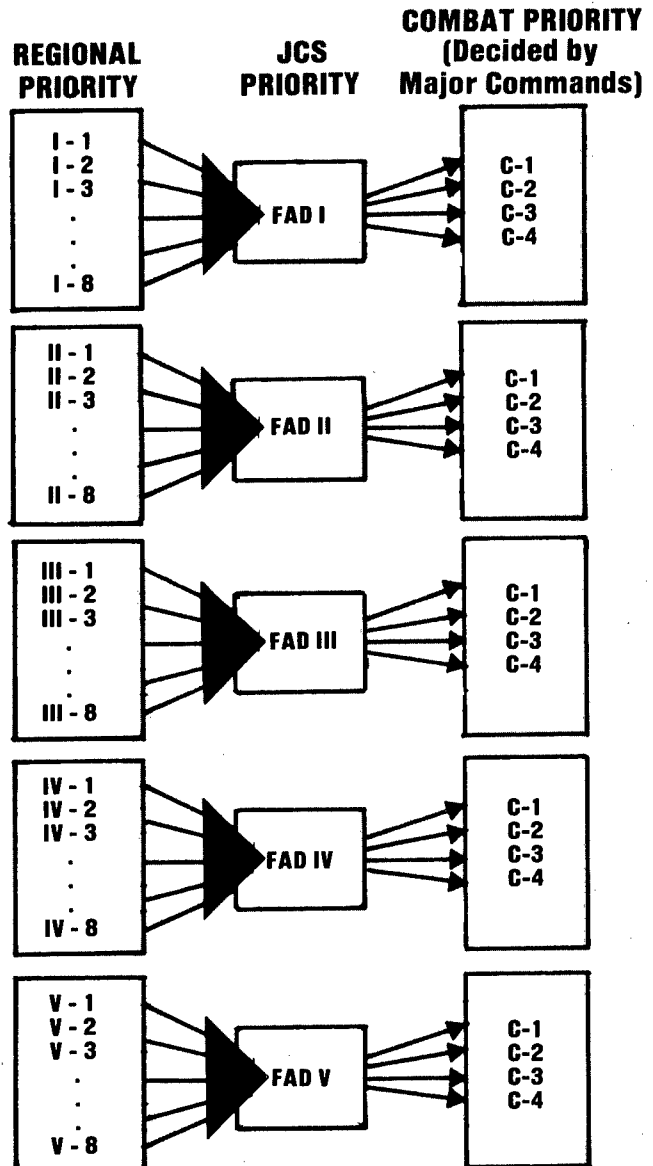
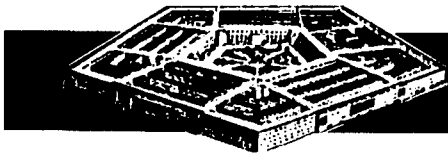

Figure 7. Hybrid operational distribution priority.

This distribution priority system is far better than the current arthritic-like UMMIPS and MILSTRIP priority structure. By linking distribution actions to specific aircraft, unit, location, and



USAF LOGISTICS POLICY INSIGHT

Vehicle Procurement Program

The vehicle procurement program is experiencing tough times like most Air Force programs in a declining DOD budget environment. Unfortunately, the vehicle program decline started in the mid-80s making the current impacts even more pronounced. During the FY92 Program Objective Memorandum (POM) exercise, we made a difficult decision to keep critical core special-purpose, materials handling, firefighting, and cargo/utility vehicles reasonably funded at the expense of others. The "others" included sedans, station

wagons, intercity buses, 23-passenger surreys, and pickups. This choice was made with full recognition that these vehicles are important too (pickups to support flight-line maintenance). None of these vehicles will be bought for FYs90-93. This tactic did preserve program funding for the critical vehicles at a respectable level. The good news is we plan in FY92 to buy out the peacetime operating stock (POS) requirements for such key vehicles as the 10K all-terrain and standard forklifts, and the 2000 and 3000 ton-per-hour snowblowers. (Lt Col Jung, AF/LEXP, AV 225-7047)

world. Furthermore, this system gives the operational commander more control over supplies within the theater—a capability that did not previously exist. Therefore, supplies can be distributed based on the same operational priorities used when supporting the Joint Force Commander's theater campaign plan. For example, supplies will be allocated according to the number of sortie generations or available aircraft needed to fly a particular mission. An example would be to allocate or reallocate supplies to support twenty F-15s to perform close air support. Those supplies could come from within the Air Force, any sister service, or from any Inventory Control Point (ICP). Of course, these objectives are ever changing because they are dictated by the battlefield environment.

Conversely, since UMMIPS and MILSTRIP are not regionally structured, aircraft availability goal oriented, or weapon system sensitive, they are unable to react to operational needs. They rely on the customer to assess the need (based on stockage objectives) and then set the priority. As a result, personal judgment, parochial desires, and forces of personality will dictate where the item manager distributes supplies.

UMMIPS and MILSTRIP can be viewed similar to one being trapped inside a stained-glass house. Although one can see through the glass, it distorts the true picture. Extending this thought a little further, judgments about this picture would probably be wrong because they would be based on wrong perceptions. Just like the stained glass, our current priority system distorts the picture by focusing on stockage goals and not combat capability.

The proposed hybrid operational distribution priority matrix allows the DRIVE system to work. The matrix is a flexible distribution priority system based on a global family of operational plans that focuses on operational needs. It enables the distribution system to respond to regional conflicts, adjust quickly to changes in flying hour activity, and distribute supplies to improve combat capability.

We can no longer rely on a system that uses a philosophy of providing "something for everyone." We are faced with a declining military budget that forces us to rely on fewer supplies and people to support our modern and sophisticated weapon systems. Therefore, we must ensure our most important customer (the warfighting unit) is kept at the highest level of

readiness. The proposed hybrid operational distribution priority matrix can make this happen.

References

1. AFSC Pub 1, *The Joint Staff Officer's Guide 1988: JCS Pubs*, 1988.
2. AFR 55-15, *Unit Reporting of Resources and Training Status (Category Levels) (Status of Resources and Training System (SORTS), RCS: HAF-XOO(AR)7112(DD))*: Aircraft Units, Chapter 4, 1986.
3. Allen, Richard. "MILSTRIP at 20: Going Strong," *Dimensions* (July 1982).
4. Appelbaum, Robert, et al. "Distribution and Repair In Variable Environments (DRIVE) Concept of Operations," Wright-Patterson AFB OH: 1988.
5. Briefing, Headquarters Air Force Operations-Logistics Working Group, Subj: Operational Priorities for WRSK/BLSS, Fiscal Year 1989.
6. DOD Directive 4410.6, *Uniform Materiel Movement and Issue Priority System*, 30 October 1980.
7. Dynamics Research Corporation. *Distribution and Repair In Variable Environments (DRIVE/D087JJK) Functional Description Version 1.3*, Anover MD: Dynamics Research Corporation, March 1989.
8. Isaacson, Karen E., et al. *Dyna-METRIC Version 4 Modeling Worldwide Logistics Support of Aircraft Components*, RAND Report R-3389-AF, Santa Monica CA: RAND Corporation, May 1988.
9. Kuhlman, Norman H. C., Capt, USN (Ret), et al. "National Security Management, Supply Management," Industrial College of the Armed Forces Study, Washington DC: Industrial College of the Armed Forces, 1974.
10. Mullins, James P., General, USAF. *The Defense Matrix*, San Diego CA: Avant Books, Slawson Communications, Inc., 1986.
11. Message, USAFE LGS 231804Z Aug 89, US Air Force Europe Director of Supply to Tactical Air Command, 23 August 1989.
12. Ogan, Andrew J., Maj, USAF. "Aircraft Availability: A Concept Whose Time Has Come," *Air Force Journal of Logistics*, Spring 1988.
13. Ramroth, Albert M., Col, USAF. "Reconfiguring Logistics To Increase Its Responsiveness," Air War College Research Report, Maxwell AFB AL: Air War College, May 1988.
14. Rich, Michael, et al. *Recent Progress In Assessing The Readiness and Sustainability of Combat Forces*, Rand Report R-3475-AF, Santa Monica CA: RAND Corporation, August 1987.
15. Seaquist, Klaus H. "Building Combat Strength Through Logistics: Translating The New Air Force Logistics Concept of Operations Into Action," Air Force Logistics Command Research Report, Wright-Patterson AFB OH: 1988.
16. Tripp, Robert S., Col, USAF. "Strategies for Logistics C³I," *Air Force Journal of Logistics*, Spring 1987.
17. Williams, Fenton L. *MILSTRIP HISTORY*, SMAMA Historical Study 53, McClellan AFB CA: Office of Information, Sacramento Air Materiel Area, 1963.



Fighter Design From the Soviet Perspective

Richard D. Ward
General Dynamics Corporation
Fort Worth Division
Fort Worth, Texas 76101

Part I

Introduction

Close observation of Soviet aircraft at recent public displays resurrected an old controversy in the West and provoked important considerations: how can the Soviets achieve Western levels of performance with apparently less sophisticated machines? And if this be the case, why not apply Soviet developmental criteria to the design of Western aircraft?

Instead, a more important question is **why** are the design criteria different? This question has been raised because apparently Western engineers follow weapon design constraints quite different from those imposed on Soviet engineers. If, when examining Soviet military systems, Western perceptions are adjusted to consider the Soviet approach to fighting a war, then much of what is difficult to understand about Soviet design practices becomes clear.

Based on in-depth studies of military sciences and history, Soviet military planners have deduced that, while the next war may be prolonged, battles will be short and intense, calling for a massive flow of replacements. As a result, Soviet warfighting concepts are based on surprise, concentration, and thrusts into the operational depth. In this context, weapons must be reliable, but only for the short-term, with minimum support requirements. It is also important that weapons be continually available in great numbers.

Recent conflicts have shown that aircraft, on the average, can only survive for a short time; therefore, there is little point to designing-in an operational life of several thousands of hours. Accordingly, Soviet planners require very high numbers of weapons and correspondingly high rates of production. To the Soviet planners, this means that simple, low-cost, reliable weapon systems must be designed to ensure that great numbers can be quickly produced.

To assure that large numbers of dependable, war-ready weapons are available at the outset of a conflict, operational weapons, in peacetime, are periodically replaced from war reserve stockpiles with new or refurbished counterparts, and the replaced weapons are in turn sent to overhaul factories. The equipment sent to overhaul is actually being returned to the factories near the peak of reliability so that, at the beginning of a war, all operational weapons will be available for a specified, reliable combat life. Combat-life requirements, therefore, determine the design life and system redundancy of all critical components.

In meeting operational demands, Soviet engineers design around relatively few, but highly standardized, components produced in a manpower-intensive, but relatively low-technology manufacturing atmosphere. To expedite

production, outside components suppliers are constrained. To ensure minimum production disruptions, use of advanced materials is conservatively incorporated; and fabrication is done by semiskilled workers using relatively unsophisticated machines and processes.

Soviet designers have evolved unique methods to increase the producibility of weapon systems, such as minimizing the number of components, and by calling for unsophisticated fabrication techniques using standardized tooling. Coincidentally, the weapons that are simply produced are also conducive to short-term operational reliability and minimal supportability.

The purpose of this paper is to trace the Soviet weapon development levels necessary to meet their criteria. Starting with a comprehensive national military doctrine, the developmental hierarchy is followed through the Soviet approach to fighting wars; next comes the determination of the subsequent weapon requirements; then the definition of the design criteria that meets the weapon requirements; and, lastly, the approach used by Soviet designers to produce weapons compatible with the military doctrine (Figure 1).

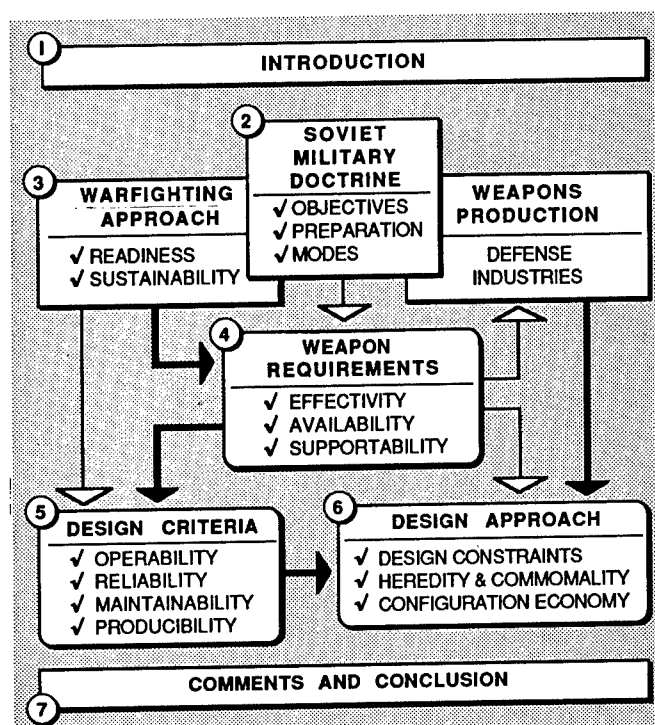

Figure 1. Soviet military doctrine determines and integrates the Soviet Union's response to the military aspects of international affairs, the contribution of the economy to defense, and the structure of the armed forces.

Military Doctrine

“Military Doctrine - is a system of views, adopted in a given state for a specific time,

(A) on the objectives and character of a potential future war,

(B) on the preparation of the country and its armed forces for such a war,

(C) and on the modes of its conduct.”

Marshal A. A. Grechko

The Soviet Union has been invaded and occupied several times in its history. Soviet losses in World War II, both military and civilian, approached 20 million people. Because of its history of wars, and especially that of World War II, the leadership resolved that the only viable approach to prevailing in future large-scale conflicts lies in the security of a highly prepared standing army backed by a comprehensive national strategy.

In preparing a foundation for the organization of such an armed force, Soviet planners meticulously studied the history and nature of warfare and defined several universal laws governing war and armed conflict. These laws address such criteria as the importance of political and moral goals, relative economics and technologies of warring nations, and the correlation of military forces. To conform to these laws, Soviet planners have established a comprehensive and dynamic national military doctrine to ensure national security and the projection of the international policies of the Soviet Government. Under this doctrine, Soviet planners rank resource allocations during peacetime so that, under emergency conditions, combat and reserve forces receive the highest support levels, and nonessential peacetime functions are curtailed (Figure 2).

(A) **“On the OBJECTIVES and character of a potential future war”**

Soviet military doctrine is formulated around the requirement for the extraordinary preparedness of the armed forces for war, including an integrated governmental structure to support the necessary preparations. It is, therefore, extremely important that the threat for which to be prepared be well-defined. Their study

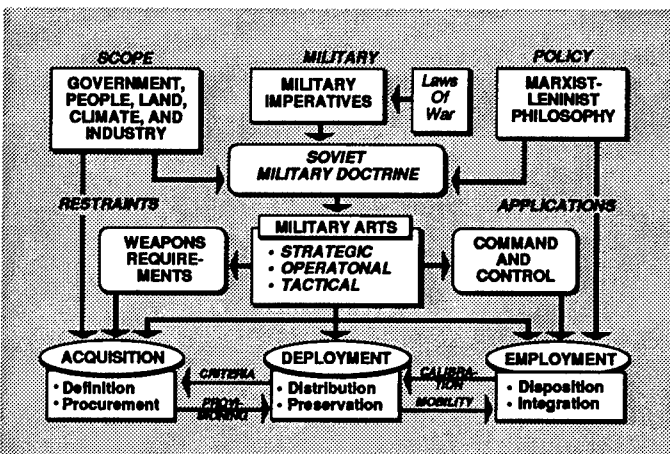

Figure 2. Soviet military doctrine is the systems analysis approach to determining the optimum balance between defense and non-defense resources allocation.

of past wars, and the resultant postulation of the nature of future wars, have disclosed that certain general characteristics can be expected:

- Enemy **surprise attacks** are probable.
- Enemy forces will have **highly destructive weapons**.
- A war between modern armies will lead to **massive losses**.

Immediately following World War II, Soviet military planners concluded the next war would be global in scope involving intense nuclear exchanges with great losses. Therefore, the Soviets developed a strategy calling for extensive nuclear forces, with a corresponding deemphasis in conventional forces. In the 1960s, however, because of the growing acknowledgment of the unacceptable destructiveness of this type of war, the military doctrine based on global nuclear war was reevaluated. Instead, Soviet leaders considered the viability of large-scale, conventional wars being fought without resorting to the nuclear option. As a result of a positive evaluation, Soviet military doctrine underwent a radical change. From the outset, however, it became apparent that the enemy's nuclear option must be eliminated, mandating an extremely high state of peacetime military readiness to provide swift pinpoint destruction of the enemy's nuclear arsenal. The foundation of this new strategy was to be a standing-start strike capability to ensure the enemy's nuclear weapons destruction—a difficult, if not impossible, task—if the former Soviet strategy of massive operations and fronts was used.

The new conventional war approach is very different from the World War II warfighting philosophy, which involved massive armies needing extensive and vulnerable mobilization before employment. The new approach calls for smaller, but more flexible, armies capable of rapid and unannounced employment. This change resulted because the smaller, more flexible army can quickly drive into enemy formations, denying them a viable nuclear defensive choice. The early destruction of the enemy's nuclear arsenal is still paramount; but, if well-defined targets are denied to the enemy, the Soviet armed forces will have more time to destroy the weapons. Since subscribing to this new warfighting approach, the Soviets have been reorienting national and international policies, reorganizing military formations, and redesigning military equipment to ensure the viability of this new, more prolonged, conventional warfighting approach.

(B) **“On the PREPARATION of the country and its armed forces for such a war”**

To understand the Soviet Union's military doctrine, a brief explanation of its governmental system is necessary. According to the Soviet constitution, the government is divided into three main branches: the Supreme Soviet, the constituent assembly; the Council of Ministers, administrator of the governmental functions; and the Communist Party of the Soviet Union (CPSU), director of national policy. In military affairs, the Party controls the Ministry of Defense through the Main Political Administration and the Defense Industries through the Defense Industry Department of the Central Committee of the CPSU (Figure 3).

As outlined by the Soviet communist doctrine, the Party-commissioned government administers the economy of the nation through a highly centralized planning system. This system, additionally, ensures the integration of industry, resources, and manpower necessary to fulfill the military doctrine. Within the context of this system, planners tailored the

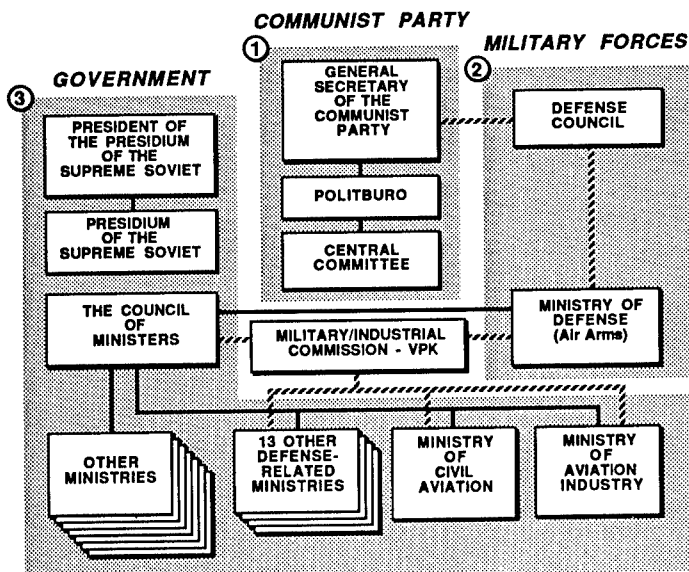

Figure 3. At the pinnacle of Soviet power structure is the Communist Party, followed by the Ministry of Defense and then the Defense Industries. Even though the Ministry of Defense is a member of the Council of Ministers, it holds much more influence than the other members.

military doctrine to the particular Soviet experiences, environment, and goals. In other words, national military policies are prioritized to reflect Soviet capabilities. Although their economic system now appears to be in the process of radical change, the parts of the system necessary to fulfill the military doctrine are still in place and will continue to focus on a strong peacetime military posture.

Soviet planners have developed a military doctrine that takes maximum advantage of their strengths and minimizes their weaknesses.

(C) "And on the MODES of its conduct."
Section V of the Constitution of the U.S.S.R.

V. DEFENSE OF THE SOCIALIST MOTHERLAND

Article 31. Defense of the Socialist Motherland is one of the most important functions of the state, and is the concern of the whole people. In order to defend the gains of socialism, the peaceful labor of the Soviet people, and the sovereignty and territorial integrity of the state, the USSR maintains armed forces and has instituted universal military service.

The duty of the Armed Forces of the USSR to the people is to provide RELIABLE DEFENSE of the Socialist Motherland and to be in CONSTANT COMBAT READINESS, guaranteeing that any aggressor is INSTANTLY REPULSED.

As dictated by its constitution, the focus of Soviet military doctrine must be the maintenance of a high state of military preparedness. However, even the strongest nation cannot afford to maintain all its armed forces continuously at full readiness. A reasonable alternative for the Soviets has been to keep adequate, first-echelon forces in a high-readiness state so that, at the beginning of a war, they can complete initial strategic objectives. After the conflict is under way, second-echelon troops, in turn reinforced by mobilized reserves, will be quickly brought to full

strength. The reinforced second-echelon troops will be used, as needed, to augment or replace the first-echelon forces. With this sequence of force allocation, the armed forces can meet initial strategic requirements before the enemy can be fully mobilized, and then complete the overall military goals, reinforced with second-echelon forces.

The foundation of the Soviet multiecheloned strategy is that first-echelon forces be especially equipped and trained so they can be maintained in a high state of readiness. The first echelon is supported by totally compatible second-echelon forces, capable of being brought quickly to full strength to sustain the inertia achieved by the first echelon.

Warfighting Approach

A. READINESS - Combat forces should be self-sufficient, manned and equipped to perform defined missions on immediate notice for specific periods of time.

B. SUSTAINABILITY - Sufficient forces, weapons, military equipment, rear installations, and control systems in operational units and reserves should be available to support initial warfighting stages and continue adequate support until industry can be fully mobilized.

The current Soviet warfighting approach is the result of a realistic assessment of modern warfare:

- Widespread nuclear conflict is not acceptable.
- Massive standing armies are no longer operationally or economically practical.
- Advanced technologies have introduced greatly increased firepower—and risks.

Throughout the Soviet postwar reevaluations of the conduct of future wars, their warfighting approach has always incorporated two overriding operational factors—readiness and sustainability. These factors are the principal ingredients of the classic Soviet operational concepts of surprise, concentration, and expeditious thrusts into the operational depth.

In Soviet terms, **readiness** is determined by sufficiency of ground and air forces maintained in a state of high preparedness, capable of seizing the initiative in any conflict. **Sustainability** is determined by the sufficiency of material and troop reserves to support the army until the conclusion of a prolonged conventional conflict. Requirements for weapons are formulated to be compatible with both imperatives.

A. READINESS

The Soviet leadership remembers well the enormous losses following the German surprise attack in World War II and are determined to never again leave the USSR vulnerable to this type of operation. They are resolute in their commitment to maintaining the capability to counter or initiate surprise actions. This resolve has resulted in the organization of select elements of the armed forces into a very high state of readiness.

The principal advantage of achieving surprise is in the reduction of the enemy's resistance; but to capitalize on the enemy's temporary weakness, the surprise must be exploited—the attack sustained. Not only must the first-echelon forces be trained and equipped to begin operations on extremely short notice, but second-echelon and reserve manpower and

materials must be quickly made available to sustain the initiative through rapid reinforcement, with troops activated **after** the battle begins.

Surprise operations can greatly amplify warfighting effectiveness, whether in the attack or the counterattack. In present terms, however, with the availability of modern sophisticated detection capabilities, surprise operations following **any** level of preparation are almost impossible. Therefore, within the current operational environment, the only way large-scale surprise operations can possibly be achieved is by attacking (or counterattacking) **without** mobilization. In other words, the likeliest way for an army to achieve tactical, operational, or even strategic surprise is to start military actions using only troops and equipment already positioned in peacetime deployment, without **any** redeployment or reinforcement—**standing-start readiness**. Practically, large-scale standing-start operations will necessarily limit the size of available forces, but the speed of advance and the subsequent seizing of the initiative should ensure that military goals will be achieved.

The problem for any military planner using standing-start operations, however, is determining the smallest peacetime first echelon size, as well as sustaining manpower and material reserves that can be practically maintained and still be effective enough to first achieve, then retain, the initiative. In view of the current shrinkage of the Soviet military forces, this size determination becomes critical to establishing first-echelon readiness levels, as well as weapon operational and technological requirements. The Soviets have chosen:

- To dedicate select combined-armed forces to full standing-start readiness.
- To maintain the bulk of its armed forces on a skeleton cadre status, which would take some time to mobilize.
- To maintain vast reserves of military equipment and ammunition with which to equip mobilized reserves.

B. SUSTAINABILITY

With the return of the emphasis on conventional warfare, sustainability gains added importance. Current Soviet peacetime sustainability preparations are the result of thorough planning, with postulated wartime operations defining reserves in terms of a specified quantity of reserve troops and stockpiled weaponry needed in prolonged conflicts. Reserve troops must be able to be mobilized with minimum preparation to sustain the initiative seized by the first-echelon troops. This readiness for mobilization is perpetuated by standing-start oriented training with a very important element of reserve unit preparedness being in the design and operating simplicity of the equipment. Soviet military planners have, therefore, determined that equipment must be highly reliable at the outset, but simple enough to be operated by newly activated reserves with minimal refresher training.

Massive material reserves are essential in the early period of a conflict until the national economy can be converted to wartime status. Once on a wartime basis, materials that have been expended in battle or destroyed by hostile action can be replaced by the defense industry. For instance, it is estimated that a significant percentage of weapons produced, such as attack aircraft, are eventually stored as material reserves. In this context, Soviet military equipment must be:

- Designed to be operated with the minimum of retraining of reservist familiar only with much earlier versions.
- Designed simple enough to be operated effectively in the combat environment.
- Designed for long-term storage.
- Designed to be produced in a wartime economy.

Under the past Soviet conventional war philosophy, numerous material stockpiles were prepositioned near the areas of potential operational employment of Soviet or client state combat units. These stockpiles included weapons, weapons and troop support equipment, munitions, spares, field pipelines, mobile bridges, and special equipment. Under the new conventional warfighting approach, employment of the past practice of widespread prepositioning of war material reserves creates several operational problems:

- Drawing materials from widespread stockpiles to support the accelerated operations of the new, smaller, flexible, and greater firepower combined arms units presents difficult problems in transport, vulnerability, and timeliness.
- Modern high-tech weapons demand frequent inspection, and the subsequent complex maintenance cycle needed to sustain stockpiles of this equipment, if widely deployed near potential war zones, would seriously degrade readiness.
- Maintaining numerous widespread and redundant stockpiles of costly advanced technology equipment is neither operationally nor economically feasible.

To meet the sustainability requirements of the new conventional war, Soviet planners are shifting from locating war reserves in numerous prepositioned stockpiles at operational level locations to fewer stockpiles concentrated at strategic level locations. The repositioning of these **mobile material reserve (MMR)** stockpiles aft, to the strategic rear, better supports the new warfighting approach by:

- Permitting warfighting materials to be delivered on paths normal to the front to better focus, concentrate, and shorten support to rapid deep penetration operations.
- Positioning high-tech equipment stockpiles near major repair and overhaul facilities for more efficient maintenance.
- Reducing redundant high-tech equipment in reserve, by concentrating stockpiles.
- Reducing the vulnerability of stockpiles by the better concealment and defense possible in the strategic rear.

The primary delivery method of the MMR, from the strategic level stockpiles to the operational level commands, will be by heavy and medium-lift fixed-wing assault transports. MMR delivery from the operational level commands to the tactical units is by medium and light-assault fixed-wing transports, and heavy and medium-lift helicopters (Figure 4). To meet the MMR concept, stockpiled items must be designed and packaged to meet airlift constraints. For instance, items such as portable roadway sections, field pipe, and mobile bridges will have to be reconfigured to incorporate structural plastics and graphite composites to reduce weight.



Figure 4. The Soviet Air Force Mil-24 Halo Heavy-lift Helicopter has a payload 20,000 kg (44,092 lbs).

To achieve standing-start readiness and in-depth sustainability, the Soviet military is developing moderately sized, highly integrated, combined arms organizations able to effect almost immediate transition from peacetime to wartime operations. What appears to many Western observers to be a conscript army built around second-rate weapons is actually a well-conceived and effective fighting force equipped with highly supportable weapons, available quickly in great numbers.

Weapon Requirements

- A. **EFFECTIVITY** - The ability of people, equipment, and facilities to perform required missions.
- B. **AVAILABILITY** - The capacity of troops, weapons, military equipment, rear installations, or command and control systems to preserve or quickly restore their combat capacity.
- C. **SUPPORTABILITY** - The acquisition of raw materials and people, their transformation into warfighting and war-sustaining systems through their peacetime and wartime employment.

The Soviets recognize that, since wars will involve large-scale operations and losses, weapons must be both effective and plentiful. In this context, operational requirements for availability must be integrated with supportability and operability. To appreciate how the Soviets integrate these requirements, an understanding of their approach to operational level warfighting is necessary, especially the initial stage of a conflict, during the transition from peacetime to wartime posture. An example of the character of the Soviet transition is found in a typical frontal aviation regiment's operations in peacetime, during the transition to war, and finally during wartime.

Peacetime Operations and Support

The foundation of the Soviet approach to readiness resides in the peacetime operations and support (O&S) cycle of its military equipment. The Soviet O&S cycle is designed around the premise that, in peacetime, postulated combat life must be preserved. This preservation is accomplished by requiring that weapons, such as aircraft, are never used in peacetime beyond that point in which the remaining reliable flight-hours would be inadequate to meet what Soviet planners have projected to be the

expected wartime combat life (Figure 5). This philosophy was developed in response to the earlier outlined readiness requirements which state that, at the beginning of a war, all combat equipment must be available to the commander for a specified and reliable combat life.

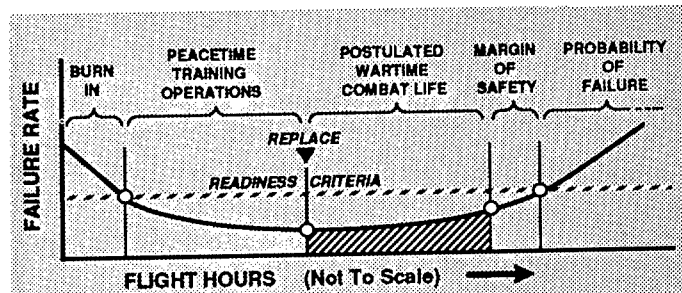

Figure 5. The combat-life requirement determines the design life and redundancy of all critical components and, therefore, the overhaul schedules.

Combat aircraft are replaced in the operational inventory while the projected combat life remains, to ensure that all remaining operational aircraft retain the projected combat life at the beginning of a conflict. This combat life preservation requirement is met by a weapons support cycle which ensures that, when peacetime training hours of the equipment have reached the point when only projected combat life remains, the aircraft are withdrawn from service and sent to overhaul factories to be refurbished, and in turn replaced with refurbished (or new) aircraft from reserve stockpiles. The withdrawn aircraft that were forwarded to overhaul factories to be refurbished are then sent to the material reserve stockpiles (Figure 6). In this way, at the start of a war, operational units are equipped with reliable aircraft, supported with abundant supplies of relatively unused aircraft retained in large reserve stockpiles.

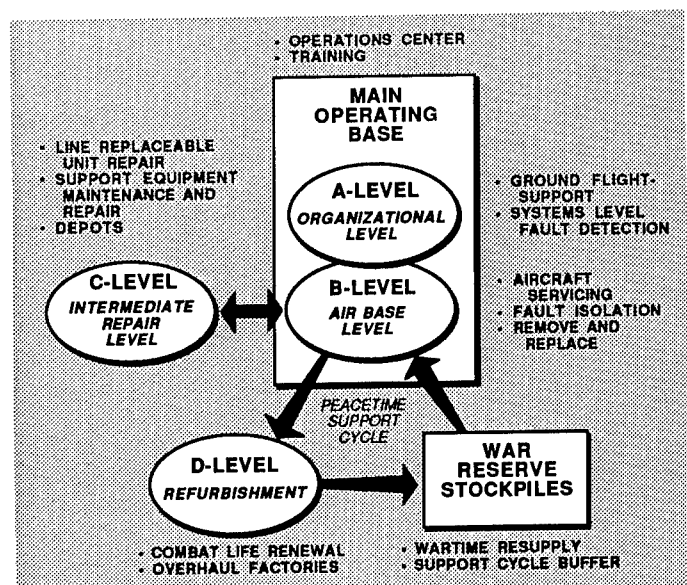

Figure 6. The Soviet Aviation O&S cycle revolves around the main operating base which contains one air regiment of about 45 aircraft.

Also with this support cycle, most of the problems of wartime maintenance and repair are also circumvented because, in peacetime, operational aircraft are never allowed to accumulate enough hours to have wearout-type failures during the postulated combat life. In other words, war reserve stockpiles of crated aircraft are used to maintain equipment readiness during peacetime by ensuring scheduled replacement of operational

equipment with new or refurbished equipment before major unscheduled repairs are required. So at the start of a war, Soviet military equipment will have few of the routine maintenance problems inherent with equipment used in extensive peacetime training.

Because Soviet weapons must be refurbished while still reliable, the overhaul cycle must be quite frequent; for example, the MiG-21 Fishbed is completely refurbished before 500 flight hours (the F-4, over 3,000 hours). This low-hour overhaul frequency for Soviet fighters has created a serious misconception in the West that the equipment is assumed to have worn out in very short order. In fact, hard-line removal schedules are based **not** on when a system wears out, but on the effective combat life remaining in the system. This system is important because: (1) a high degree of wartime reliability is ensured; (2) air base level repair frequency and troop training requirements are minimal; and (3) standing-start employment is practical. Consequently, combat-life projections are the single most important factor in the design life and system redundancy of all critical weapon components.

In peacetime, to maintain operational aircraft on a main operating base (MOB), all air base level maintenance and inspection are done from mobile repair shops - Soviet acronym PARM. These truck-mounted shops are on call for both scheduled and unscheduled maintenance. If the repair is minor, the failed module is repaired by the PARM personnel at the MOB; if the repair is major, or even moderate, the module (or the whole aircraft) is crated by the PARM crew and sent to an off-site intermediate-level repair depot. In this way, air bases can be operated with only a few highly skilled personnel and

sophisticated repair facilities. Also, organizational level (ground crew) activities are limited to simple sustaining maintenance, inspection, and supervision of aircraft servicing. In summary, the sole responsibility of the air base and organizational level activities is to keep operational aircraft continuously maintained in a "run-in" state, therefore keeping the squadrons approaching full strength and ready for wartime operations at a moment's notice.

Transition from Peacetime to Wartime Operations and Support

All the maintenance procedures and equipment employed on the peacetime air base are optimized for standing-start wartime deployment. As shown in the peacetime O&S cycle, the Soviets have developed this capability by employing mobile support organizations, or PARM units, with specialized weapons support equipment to perform peacetime aircraft and airfield maintenance.

The reason for the total mobility of support facilities is to assure that complete aviation regiments can be transported quickly to austere dispersal sites. This deployment option is practical due to the limited maintenance responsibilities on peacetime bases resulting in smaller support units allowing complete tactical aviation units, including flight-line support, air base level repair shops, inspection and armament vans, and flight operations control vans, **and towed war-ready aircraft**—to be convoyed to remote sites (Figure 7). It is important to note that towing aircraft eliminates exposed flight and radio traffic, normal during conventional dispersal operations in which aircraft must be flown to remote sites. Incidentally, Soviet

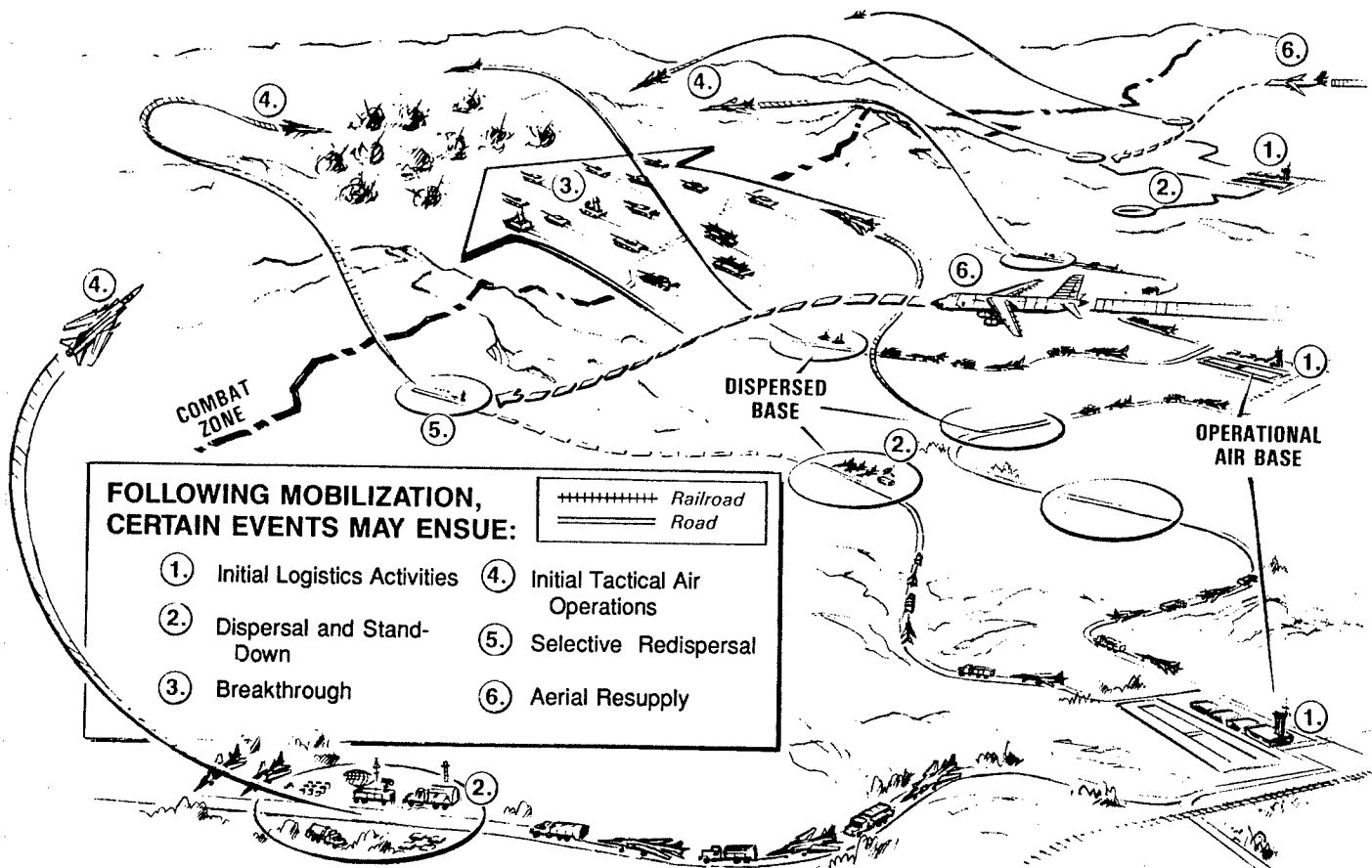

Figure 7. The initial activities of a war are critical to attaining the initiative. If feasible, the air regiment, including the aircraft, will be deployed by convoy under the cover of darkness. If the conflict has started, and therefore clandestine dispersal impossible, the aircraft will be launched on the first sortie and recovered at the dispersed base with beacons.

fighters are designed to be towed with specially designed tow bars at 20 km/hour.

The transition from a peacetime to a wartime posture involves an important change in the O&S cycle (Figure 8). The principal modification is that the overhaul factory and repair depot activities are suspended because the Soviets believe that, in the "fog of war," these operational O&S functions would only be a complicating factor. Anyway, damaged aircraft needing repairs above the dispersed base maintenance support level are usually nonrepairable—a situation unique to aircraft. Instead of repairing aircraft with major battle damage, replacements are drawn from large war reserve stockpiles, a simpler and faster approach that also allows smaller, lower-skilled battle damage repair crews.

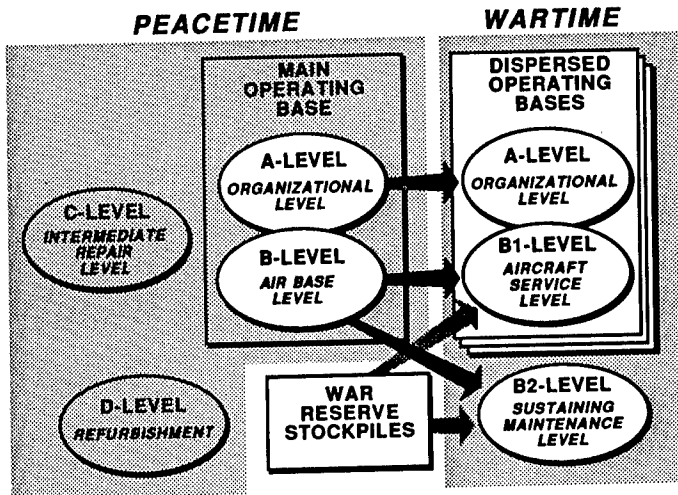

Figure 8. At outset of the conflict, the organization of the air regiment, on a main operating base, will be converted from a single entity to a centralized command, control, and support unit at the hub of several small austere aircraft air bases, each base equipped only for servicing and sortie generation.

The principal means of dispersing the individual aircraft is to be towed by the assigned organizational level aircraft support truck. Not only can this truck tow the aircraft to the dispersal site, but maintenance can be directed from it upon arrival. The aircraft, along with the aircraft-support truck, is considered a weapon system, ensuring a successful bottom end of the "standing-start" combat readiness. With the support truck, wartime aircraft deployment can be accomplished immediately and clandestinely, irrespective of weather or time of day. In summary, the aircraft support truck provides organizational level support to the aircraft on both the MOB in peacetime and the dispersed operating base (DOB) in wartime, and it provides towing between the two during the transition to war.

Wartime Operations and Support

The Soviets have always relied heavily on dispersal as a means of basing combat aircraft to keep up with the moving battlefield. Additionally, under the current conventional war doctrine, they also view dispersal as important for operational flexibility and aircraft survivability reasons:

- (1) To advert attack by complicating enemy targeting.
- (2) To preserve aircraft when the main base is likely to be placed under attack.
- (3) To evade imminent nuclear attack.
- (4) To ensure safe storage of ready reserve assets.

In the context of standing-start readiness, the austere site deployment mode has become more important; and, although modern technology and the accompanying complexity of aircraft systems must impose severe restraints on operations from austere locations, current Soviet aircraft are still designed to be operated in this manner.

Aircraft must be designed to be compatible with austere site deployment requirements and therefore are heavily influenced by the austere site environment:

- The (air) bases must be dedicated to efficiently conduct rapid and timely combat operations, but house only limited support facilities.
- Aircraft must be able to operate from semi-prepared sod runways.
- The combat support equipment must be designed to conduct maintenance on aircraft under wartime conditions.
- For security, deployment sites must be small, so operations must be conducted with only small ground crews.
- Aircraft inspection and repair equipment must be rugged, compact, and mobile for on-call support of aircraft on austere bases.

The dispersed airfield has the added inherent capability of being able to receive airborne deliveries of MMR from the strategic stockpiles (Figure 7). As described in the *sustainability* section, the primary delivery method for material reserves from the strategic-level stockpiles to the front is by heavy-lift assault transports. These aircraft will operate between strategic-level airfields near reserve stockpiles and dispersed operational level bases near combat areas. In this way dispersed air bases actually have dual wartime functions: first, to support attack aircraft and, second, to receive material reserves from strategic stockpiles for both tactical and operational air and ground operations.

A. EFFECTIVITY

Each Soviet weapon is developed in relation to the capabilities of all other weapons types, in close relation with them and in such a way that the weak points of one are compensated for by the stronger points of another.

Lt Gen Ivan G. Zavyalov

Soviet military planners have determined that each new weapon system must be evaluated relative to its effectiveness in conjunction with complementing weapons. The effectiveness evaluation of each weapon's contribution to the overall mission requires that a balance be struck between cost, numbers, reliability, and warfighting capability. Because the aircraft is considered to be only one of the many assets assigned to the Soviet commander, the task of aircraft and therefore its design specifications are defined in the context of combined arms operations. Aircraft need only fulfill a complementing role in the commander's overall mission and not a role based on maximum possible performance. The Soviets also believe that because of the fog of battle, weapons—specifically aircraft—should be optimized to only one mission to minimize the system's complexity, simplify support, and allow less extensive training. In other words, single-mission criteria, in conjunction with limited performance requirements, allow weapons to be very cost effectively designed, if produced in sufficient numbers

to overcome a possible advantage of higher technology enemy equipment.

In the Soviet view, system sophistication should be determined primarily by the technical qualifications of maintenance personnel functioning in a wartime environment. Therefore, a reliable aircraft, easier to support and maintain, is more effective because it is more dispersible—thus, survivable—and has a higher sortie rate over a longer time. This wartime operational approach dictates certain peacetime requirements:

- Frequent scheduled inspections and overhaul.
- Very simple design criteria.
- Overdesign of all critical components.

B. AVAILABILITY

Readiness is most visible in the Soviet method for ensuring troop and weapons (aircraft) availability for rapid transition from a peacetime to a wartime posture. In peacetime, the availability of reliable aircraft for wartime operations is ensured by the combat-life preservation support cycle. Availability is also ensured by large material reserves, incorporated to sustain the peacetime support cycle, because in wartime the same reserves will be available to replace combat losses.

C. SUPPORTABILITY

Successful military operations call for a discreet balance of combat operation and combat support capability. Neither function has reign over the other because both are interdependent aspects of warfighting. The design of weapons should, therefore, be influenced as much by supportability and maintainability as by performance. In the Soviet context, supportability requires simple and fast maintenance and servicing with minimal support equipment and crews. Performance must be compatible with these requirements. In fact, several past Soviet weapon prototypes have been rejected for production because of supportability problems, although they were superior in performance to competitive designs.

In response to the military imperatives of readiness and sustainability, Soviet weapon requirements are based on very specialized interpretations of availability, supportability, and effectivity. The criteria for Soviet weapons design are to ensure

that weapons are *operable* within the context of the combined arms organizations, *reliable* enough for commanders to depend on high levels of availability, *maintainable* in a realistic wartime environment, and *producible* in great enough numbers to preserve reliable combat life and replace wartime attrition.

References

This paper is based primarily on personal contacts with several Soviet designers, pilots, and technicians, including close inspection of several of their current military and civilian aircraft. Not only did the Soviets readily furnish extensive information on their aviation industry but they also supplied confirmation of several earlier postulated design and operational features of Soviet aircraft.

Several published sources were also used in the research for this paper, including some of mine. The following are several of the more useful.

Books

- Aviaexport, *Aviation Metallurgy of the USSR*.
Baxter, W. P. *The Soviet Way of Warfare*, Brassey.
Eyer mann, K. H. *MiG Flugzeuge*, Transpress (GDR).
Glaglev, A. N. *Construction of the Aircraft*.
Handbook for the Aviation Rear Specialist.
Hemsley, John, *Soviet Troop Control*, Brassey.
Matveyenko, A. M. *Airfield Braking System of Aircraft*, Moscow Press.
Soviet Military Encyclopedia.
Taylor, John W. R. *Jane's All the World's Aircraft*, Jane's Publishing.
US Army FM100-2-2.
Vigor, P. H., *Soviet Blitzkrieg Theory*, St. Martin's Press.

Reports and Papers

- Bodansky, Yossef. *The Soviet Threat to NATO Air Bases*, General Dynamics, 1989.
Brower, K. S. and Kehoe, J. W. *US and Soviet Weapons Systems Design Practices*, International Defense Review 6/1982.
Director A/S Studies, Kirkland AFB, *Strike Option Comparison Study*, ASCMD/SA.
Lowy, S. H. *Impact of Soviet Logistics Concerns on Aircraft and Gas Turbine Design*, Center for Strategic Technology.
Savkin, V. Ye. *Basic Principles of Operational Arts and Tactics (USAF)*.
Soviet Army Studies Office, *The Soviet Conduct of War*, Fort Leavenworth, US Army.

Magazines

- Air Force Magazine*, *Aviatsia i Kosmonautika* (Soviet Air Force Magazine), *International Defense Review*, *Jane's Defense Weekly*, *Lettecvi i Kosmonautika* (Czechoslovakian Air Force), *Military Logistics Forum*, *Soviet Military Review*, *Tyl i Snapzheniye* (Soviet Military Logistics), *Tekhnika i Vooruzheniye*, *Vozdushny Transport*.

(Part II of this article will be published in the Winter issue.)

Recommended Reading

"National Strategy and Mobilization: Emerging Issues for the 1990s" by Thomas H. Etzold
(Winter 1990 issue of *Naval War College Review*).



CAREER AND PERSONNEL INFORMATION

Civilian Career Management

Accurate Records

Civilians should remember to monitor, at least annually, their experience, training, official mailing address, and telephone number as reflected in the Personnel Data System-Civilian (PDS-C). The LCCEP PALACE Team members at Randolph AFB can **no longer change the individual address and phone number**; we are dependent solely on the data from the PDS-C. This means that AF Form 420, Change of Address, is no longer needed by the Logistics Career Program. The CCPO should provide each person with a career brief once a year. Personnel should not blindly accept their experience skills coding, if they do not understand it. They should ask their CCPO for a list of skills codes and definitions. If their experience coding is not current, they may not be referred for a position for which they are qualified.

Geographic Availability

All registrants should take the time to look at their current geographic availability. Many changes occurred in the Air Force over the past year which may affect one's interest in certain areas. The most significant of these changes is the announcement of base closures. We recently reviewed our records and found that 3,609 people are registered for the five bases scheduled to close. We are not recommending that individuals change their registration for these bases if they want to go there. But, if the announced closure changed their mind, then their geographic availability registration should reflect this change. It could save them a penalty—which could save them a possible promotion.

LCCEP Declination Penalty Policy

The following is a reminder of the LCCEP declination penalty:

a. **Promotion Certificates:** The LCCEP program administrators are calling promotion candidates outside the local area to determine interest in each position. If candidates decline twice, after being called, they are placed on a six-month penalty. If they are placed on a certificate and then decline to be interviewed, they will be placed on a six-month penalty. If candidates are selected for a position and then turn that position down, they are placed on a 12-month penalty. If they are Cadre members, they will be removed from Cadre but will be allowed to recompute in the next cycle.

b. **Reassignment Certificate:** The LCCEP program administrators will not contact a reassignment candidate. If individuals are on a certificate as reassignment candidates and

decline consideration for a position, they are put on a six-month penalty. As with promotion certificates, if candidates decline after being selected, they are placed on a 12-month penalty.

c. **Penalty:** Being on penalty means individuals are not referred for promotion or reassignment on any LCCEP vacancies. Since approximately 25% of the logistics positions are managed by LCCEP in grades 12 and above, it is certainly not in one's best interest to be put on penalty. The single most important thing individuals can do to avoid this is to periodically update their geographic availability. They can do this by contacting their local civilian personnel office for assistance in updating AF Form 2675, Registration and Geographic Availability.

New Policy on Career Program Overseas Employment and Return Placement Program

Effective 15 December 1989, the Civilian Career Programs implemented a new policy on Career Program Overseas Employment and Return Placement Program. Stateside activities will no longer have to obligate a specific position for the return of an employee who accepts a career program position overseas. The servicing Civilian Personnel Office will determine the appropriate assignment entitlement and counsel the employee prior to acceptance of the overseas position. The employee will sign an Overseas Employment Agreement (Career Program Assignment) which specifies the installation or geographic area for return placement. Employees will be encouraged to elect follow-on assignments designed to use the knowledges, skills, and abilities acquired in the overseas assignment. Each career program PALACE Team will work with the employee to effect a return placement that is in the best interest of both the employee and Air Force. Should an employee reach the end of the overseas tour without a follow-on assignment through the career program, the employee will be returned either to the installation or geographic area agreed to in the Overseas Employment Agreement (Career Program Assignment). This new approach to career management is expected to improve utilization and placement of key civilian employees, while enhancing management's flexibility in managing positions vacated by employees accepting overseas career program employment.

Real Estate Expenses

a. Comptroller General (CG) Decision, B-233829, 15 Sep 89, responded to an Air Force question on whether an employee is entitled to residence transaction expenses when the employee contracted to sell and vacated his old residence before he was first definitely informed of his transfer. The employee contacted a selecting official about the possibility of obtaining a position

and, upon receiving a favorable reply, placed his home on the market. The employee signed a contract to sell the house one month prior to being formally offered the position. In addition, the employee agreed to allow the buyers to occupy the house while the loan application was being processed.

b. The CG ruled that (a) the sale of the residence was not incident to the transfer and that (b) because the employee did not reside in the residence at the time he was officially notified of the transfer, he was ineligible for real estate expenses.

c. Employees should be counseled not to take action to sell their home or vacate the premises until they have received a formal offer. Employees may not be reimbursed for any PCS expenses that were incurred before a transportation agreement is signed.

Air Command and Staff College and Air War College

It is not a very well-known fact, but the Air Command and Staff College (ACSC) and the Air War College (AWC) can be completed not only in-residence but also by seminar or by correspondence. AFR 50-5, *USAF FORMAL SCHOOLS*, gives additional information such as minimum grades, prerequisites, and special requirements. So, those who thought these schools were beyond their reach can now enroll without having to leave their work or home environment. And that is not all. Are civilians aware that universities will grant graduate level credit for attending Air Command and Staff College and the Air War College? Well it is true; and they give this credit for attending in-residence, by seminar, and in some cases by correspondence on a case-by-case basis.

(If you are interested in completing these schools, please contact your local education office.)

(Glenda Lukens, HQ AFPCMC, Randolph AFB TX, AV 487-5631)

Logistics Professional Development

Logistics Officers in the Joint Arena

After passage of the Goldwater-Nichols Department of Defense Reorganization Act of 1986 and, more specifically, Title IV of this law, clear guidance was provided for the selection, education, assignment, and promotion of officers in joint duty. A joint duty assignment (JDA) is an assignment to a designated position in a multiservice or multinational command or activity that is involved in the integrated employment or support of the land, sea, and air forces of at least two of the three military departments. Some of these JDAs are further identified as critical joint duty assignment (CJDA) billets. The critical aspect is based on the need to have educated and experienced officers in joint matters in those billets. Currently, the joint duty assignment list (JDAL) identifies 230 field grade logistics joint requirements, both in CONUS and overseas locations.

Under the provisions of Title IV, officers selected for JDA must complete an approved joint professional military education (JPME) program and must be accepted by the joint agency. Once officers have met these requirements, they become joint specialty officer (JSO) nominees, and only after they have completed a JDA and are recommended by the Secretary of the Air Force to the Secretary of Defense, will they be designated

JSOs. The law further requires that JDAs be filled with at least 50% JSOs or JSO nominees, and that CJDAs be filled by 100% JSOs by January 1994. Under this new guidance, logistics officers will have greater opportunities to bring their field experiences into the joint arena. With the exception of missile maintenance (31XX), each of the logistics career disciplines has JDA billets. The following provides a quick reference listing by AFSC and experience levels:

Aircraft Maintenance/Munitions Officers (40XX): There are 31 joint duty (JD) positions, of which two are critical. These positions are found in joint agencies such as USEUCOM/SHAPE, JCS/OSD, DNA, NATO, CENTCOM, and PACOM. Eighteen of these positions require a munitions background. Nineteen of these positions are overseas, with eight being in short tour locations. Three positions require language training in Arabic, German, and Portuguese.

Transportation Officers (60XX): In this career field, there are 54 joint duty positions, with one coded critical. These positions are found in the Military Traffic Command, Military Sealift Command, Military Airlift Command, US Transportation Command, USEUCOM, NATO SOUTHCAM, ESC, DLA, PACOM, SOCPAC, JSOC, CENTCOM, AFSC, OSD, OJCS, DCA, SOUTHCAM, Defense Courier Service, US Forces KOREA, and ROKUS. These positions require heavy emphasis on transportation planning and experience in either air or traffic management. Seventeen joint duty requirements are overseas. Four positions require language training in Italian, Spanish, or Korean.

Supply Officers (64XX): Supply officers fill 47 joint duty positions (of which five are coded critical) in 13 different joint agencies, such as DLA, DNA, security assistance activities, JCS, NATO, CENTCOM, USEUCOM, LANCOM, PACOM, and DISAM. Twenty-eight of these positions require a strong supply background; 19 positions require fuels experience. Five of the fuels billets are coded critical (of which four are commander positions). Language training in French, Portuguese, or Turkish is required for three JDAs.

Logistics Plans Officers (66XX): The majority of the joint duty requirements are found in this career field. There are 98 joint duty billets (of which 11 are coded critical) in 16 different joint agencies. Language training in Italian, Dutch, Spanish, Turkish, Indonesian, Thai, Norwegian, or Serbo-Croatian is required for some JD positions. A strong background in some of the following areas is necessary: security assistance, foreign military sales, host nation support planning, war planning, and reserve materiel management experience. Currently, logistics officers other than 66XXs are helping meet the high demand in this area.

Joint duty tours offer great career opportunities. Officers assigned to joint duty requirements will receive a wealth of experience working with the various services on issues involving the security of our nation. Joint duty tours are fast-paced, demanding, and very rewarding; and the experience received in this type of environment enhances the logistics officer's potential. Interested officers should contact their HQ AFMPC assignments action officers.

(Lt Col G. B. Vega, Chief, Logistics Officer Assignments Branch, HQ AFMPC/DPMRSL, AUTOVON 487-3873)

AFIT

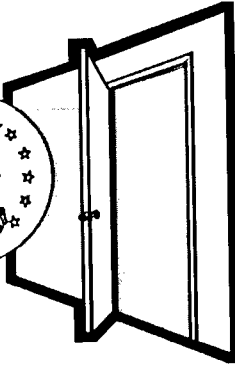

The Doorway to Logistics Success

The Air Force Institute of Technology's School of Systems and Logistics

Colonel Richard S. Cammarota, USAF
Dean, AFIT School of Systems and Logistics
Wright-Patterson AFB, Ohio 45433-6583

The Air Force Institute of Technology's School of Systems and Logistics (SOSL), Wright-Patterson AFB, Ohio, while expecting many challenges from the future, finds the present is abundantly busy. Notwithstanding the reductions in defense resources, the school will meet those challenges and perform its current tasks, in large part because of its varied and thorough curriculum of graduate and continuing education.

The school has an overall goal to enable its graduates to better perform the technical managerial tasks required to meet missions and to improve their critical thinking skills. Successfully meeting this goal leads to effective leadership.

Distance Education

The school is committed to having the most current technology available to serve its faculty and students. It is actively using the upgraded television capabilities located in its first floor TV studio—the Video Classroom.

While television production capabilities have been used for a number of years to produce videotapes for distance education, recent upgrades have improved the ability to output signals to the AFITNET TV systems, the base TV cable system, and the satellites. Soon to be added will be the capability to improve the character generation for lecture videos and to use the TV mixing boards with direct computer input. These gains will help support faculty involvement with distance education.

The school is already using exporting technology in several of its continuing education courses. For example, Systems 100 (SYS 100), the first in a three-course sequence to prepare Air Force people to work in program offices, has been in "enhanced seminar" format for four years. By using experienced Air Force members who have been through the first two AFIT systems acquisition courses in residence and received AFIT's facilitator training, it reaches people at locations away from Wright-Patterson. In 1988, it reached 1,500 people. Last year, the total was 1,700. This year AFIT is educating at a rate that will reach 3,000 people.

Another faculty member is working with Air Force Logistics Command to develop a video-tailored version of a long-standing materiel management course. When ready, the course will be

delivered to AFLC students across the command over the AFLC Video Teleconferencing Network.

Curriculum

The curriculum is always the core of any school's reputation. The newest curriculum change in the School of Systems and Logistics is the addition of the graduate software systems management option. The school specifically designed this program, which will produce its first graduates in 1991, to meet Air Force needs in software management. Graduate students will study such subjects as discrete mathematics; program design; mainframe, mini, and desktop computer systems; economics; research methods; embedded software; quality assurance; management science; statistics; communication; organizational behavior; management theory; software systems; federal financial management; contracting and acquisition management; and the generation, analysis design, configuration, and costs of software—as well as write a master's thesis.

Other detailed changes to the school's curriculum illustrate its commitment to keeping current with changing times in the military world. Graduate programs currently include contracting management, cost analysis, engineering management, information resource management, logistics management, and systems management.

A key development within the graduate engineering management program reflecting national concerns with the responsibility for hazardous waste disposal is the addition of three environmental courses: Environmental Law and Policy, Environmental Systems Engineering, and Environmental Risk Assessment.

Contract Education

Broad changes are not just occurring in the graduate program. In continuing education, the Acquisition Enhancement program, or ACE, is changing the way the school does its business. Because the Department of Defense has centralized the management of funding and student requirements in one location, AFIT is now officially what it has essentially been for years—a DOD school. The school teaches 10 of the 23 ACE mandatory courses in contracting management and acquisition. The requirements for 2 of the 10 courses, Government Contract Law and Cost and Price Analysis, are so substantial that neither AFIT nor the other-service certified offers can meet them. Consequently, the school is currently contracting offerings of those courses to supplement its organic teaching capabilities.

Graduate Student Development

Since the school has few civilian graduate students, the area of student development is more properly defined as officership

development. Today, merely giving officers an academic orientation is not enough. The academic studies must compete after they graduate and must also allow officers the opportunity to develop their critical thinking skills. Thus, what AFIT defines as student development really amounts to two things: leadership and thinking.

The school is planning to increase student leadership roles and show that the principles of academic success are not unrelated to mission success on the battlefield. For example, in many courses such as thesis-related courses, communication courses, and computer courses, students take responsibility for teaching peers, conducting graduate seminars, and presenting materials through lectures.

Critical Thinking

The school has worked for many years to improve the critical thinking of its students as part of their development. Within the last several years, the faculty declined to delete the master's thesis requirement in lieu of additional courses or a shorter research project as many other graduate schools have done. The unique nature of the military graduate school demands that students prove, without the clutter of various options, that they can meet minimum standards of critical thinking by conquering the formidable requirement of conducting a major independent research project, formulating the results, and justifying the conclusions in a well-written document.

While all graduate classes contribute to the development of critical thinking skills, the school regards the thesis as the crowning achievement of student development. Coming together in the thesis are the sense of responsibility, the need for critical time management, the application of numerous "lessons learned" from the graduate courses, the opportunity to work "one-to-one" with distinguished faculty members, and the interaction with peers who are also under pressure to graduate on a specified date.

Additionally, the school is concentrating its efforts on increasing the scope of its sponsorship program. Under this program, student theses are "sponsored" by a DOD agency. Such sponsorship gives the student additional research focus and a real-world target. The sponsoring agency can help students "open doors" to research data and material and help them tailor the work to current DOD research issues. Often, sponsoring agencies will also offset TDY expenses for research as well as an end-of-work briefing to its senior leaders of the thesis results.

Faculty Research

As in any good graduate school, the faculty is also hard at work on several important research projects. Several faculty members are closely involved with the logistics, financial, and contracting communities in quality management and how it helps those organizations operate better. AFIT's cost analysis faculty is working on ways to predict the costs of maintaining software and the scheduling necessary to develop software on schedule. One faculty member has, for the past year, been the sole programmer for a new software tool that supports a Headquarters Air Force test program to allow Air Force units to manage their civilian resources to the money in their civilian pay budget, not solely to manpower requirements.

The future of the school is based upon a partnership between the faculty, students, and administration. Planning is the key to enhancing the quality of the school's academic environment, and this planning is an ongoing function of the school through its

combined efforts of administration and faculty committees based upon the student feedback from each class.

As the technology of the world continues to grow, I believe that H. G. Wells may have stated the role of education today best when he said, "Human history becomes more and more a race between education and catastrophe."

In a changing political and military world, education becomes the one constant tool for success, and the graduate and continuing students at the AFIT School of Systems and Logistics are well prepared for that success. (For more information on AFIT's School of Systems and Logistics, contact AFIT/LS at AUTOVON 785-5361.)

In September 1990, the class of 1990S/D, School of Systems and Logistics, completed 143 theses. The best of these theses received the Dr. Leslie M. Norton Pride in Excellence Award:

TITLE: *Executive Information Systems for USAF Hospital Administrators: A Feasibility Assessment*

AUTHOR: Captain Alan R. Constantian

This study investigated the feasibility of implementing an executive information system (EIS) for hospital administrators at CONUS-based USAF inpatient medical facilities. A literature search determined successful system implementation would require that such an EIS be technically, economically, operationally, and motivationally feasible. Failure to meet any of the feasibility factors would jeopardize successful implementation.

Surveys were mailed to each of the administrators and medical systems officers of the target population to gather data on these feasibility issues. There was strong support for an EIS among hospital administrators, thus making EIS feasible from a motivational perspective. However, indicators of technical and economic feasibility brought mixed results, and an EIS does not appear feasible from an operational perspective at the present time. The information system infrastructure and the technical expertise and size of local medical systems sections must be augmented for an EIS for USAF hospital administrators to become a fully feasible option.

TITLE: *Aerial Ports in Low Intensity Conflict (LIC): Vietnam, Grenada, and Panama*

AUTHOR: Captain David J. Parker

The Vietnam War through 1968, Operation Urgent Fury in 1983, and Operation Just Cause in 1989 were analyzed to determine the role and effectiveness of aerial ports in LIC. Within the DOD definition of LIC, four broad categories were identified; among them insurgency/counterinsurgency, peacetime contingency operations, and peacekeeping were singled out as most probable to require aerial port logistics support.

The results of this research indicate that aerial port forces in LIC must be prepared to provide extremely mobile, combat-ready units. These aerial port forces must also be prepared to function under austere conditions and operate specialized equipment. LIC is not business as usual.

Another finding indicates that the tactical and strategic role differentiation between aerial port forces that developed after the Vietnam War is no longer logical nor valid. Aerial port forces are not currently fully capable of successful involvement in LIC

because of geographic, doctrinal, and functional divisions that exist. Options are presented that, if implemented, could successfully improve aerial port capabilities in LIC operations.

TITLE: *Forecasting AFLC Second Destination Transportation: An Application of Multiple Regression Analysis and Neural Networks*

AUTHOR: Captain Kevin R. Moore

The Air Force Logistics Command (AFLC/DSXR) currently uses a simple linear regression model to forecast overseas Second Destination Transportation (SDT) general cargo tonnage requirements for specific geographical areas. The independent variable for the model is the total flying hours for each geographical area.

This research developed multiple regression and neural network models for predicting Pacific (PACAF) and European (USAFE) Military Airlift Command (MAC) and Military Sealift Command (MSC) general cargo tonnage requirements that were more accurate forecasting models than the simple regression models presently used.

Overall, the multivariable model development approach significantly increases SDT forecasting accuracy. The neural network models were the most accurate forecasting models. In three out of the four data sets used, the multiple regression models produced more accurate forecasts than the AFLC/DSXR simple regression model. The application of either model would significantly reduce the financial implications of overestimating and underestimating SDT tonnage requirements.

TITLE: *Productivity Measurement in Aircraft Maintenance Organizations*

AUTHOR: Captain Billy J. Gililland

This research explored productivity measurement in aircraft maintenance units and examined the relationships of the measures used to evaluate a unit's productivity. Review of current literature and regulatory guidance concerning productivity measurement provided the basis for the

development of an interview questionnaire which was administered to DCMs and chiefs of analysis at 10 MAC wings. Additionally, managers in the maintenance management, cost, and manpower divisions at Headquarters MAC were interviewed. From these interviews, information concerning productivity measurement methodology was gathered and 13 measures were identified for analysis.

Of the 13 measures, 8 produced the strongest explainable model reflecting maintenance productivity. Man-hours per flying hour was the predominant output when viewed as a result of the influence of mission capable rates and maintenance scheduling effectiveness. Cannibalization rates, delayed discrepancies (both awaiting parts and awaiting maintenance), and the average number of aircraft possessed appeared to contribute most significantly to mission capable rates and maintenance scheduling effectiveness.

TITLE: *Evaluation of the Effectiveness of the Storage and Distribution Entry-Level Computer-Based Training Program*

AUTHOR: Captains Mark A. Donovan and Michael E. Guy

Currently, there is no in-residence technical training course for Supply warehousemen, AFSC 645X1. Therefore, base-level supervisors and trainers provide the initial technical training for direct duty assigned airmen in this AFSC. Given the absence of a formal technical training course, most base-level supply squadrons use the 64531 Career Development Course (text) to train their direct duty assigned warehousemen. The purpose of this study was to compare the effectiveness of Computer-Based Training (CBT) with the commonly used text training, using a CBT module developed by the new supply CBT development team, located at Lowry AFB, Colorado. The results of this study have shown that, when used properly, CBT can increase the amount of learning which takes place, increase the ability of trainees to perform the tasks for which they are trained, and reduce total training time. This research directly supports the Air Force's continued use of CBT for the initial training of supply warehousemen and further suggests that CBT may be a suitable technique for other Air Force training needs.

Most Significant Article Award

The Editorial Advisory Board has selected "Let's Join the Quality Revolution" by Colonel Kenton R. Ziegler, USAF, and Colonel John T. Twilley, USAF, as the most significant article published in the Summer 1990 issue of the *Air Force Journal of Logistics*.

Logistics Support Limitations in the Vietnam War: Lessons for Today's Logisticians

Major Benjamin L. Dilla, USAF
Division Chief for Leadership Corps
Department of Behavioral Sciences and Leadership
US Air Force Academy
Colorado Springs, Colorado 80840-5671

In these times of changing world conditions and perceptions of a changing threat, the United States (US) military will be called upon to reevaluate and justify its force structure and combat capability. Our nation must maintain a military force which is a viable deterrent against aggression and is capable of projecting power around the world in many areas of interest and importance.

It is more important than ever that we study the lessons of history to avoid the mistakes of the past under similar circumstances. In each of the major wars of this century—World War I, World War II, Korea, and Vietnam—the US has been unprepared. Logistically, we lacked realistic planning and a system-in-being for immediately deploying and sustaining combat power. These problems were costly and dangerous. In the case of our conflict in Southeast Asia, it is probable that our lack of preparation, wisdom, and resolve cost us victory. Because of its unsuccessful outcome, we need to better understand the lessons of US involvement in the Vietnam War and their application to readiness today.

Many have written about the US experience in the Vietnam War, trying to explain what went wrong and why, usually from a political perspective. This paper looks strictly at the military side of the conflict and specifically at US logistics support. Logistics is here defined as “a system established to create and sustain military capability” (7:iv) and includes the functions of planning, procurement, supply, transportation, maintenance, manpower, and personnel.

My intent is to show that logistics contributed to the US failure to win the Vietnam War. At best, logistics was symptomatic of the nation's aimless and halfhearted involvement in the conflict. At worst, problems of logistics support made the war unsustainable and unwinnable even if the nation had been committed to win. To justify this position, the paper will examine four related facets of logistics support in the conflict—poor logistics planning prior to US involvement, problems during the buildup period, constraints in the early prosecution of the war, and long-term system inefficiencies.

A look at logistics plans and preparations will show the US was not prepared to fight a war in Southeast Asia. The lack of plans produced great turmoil and delays in the buildup of capability in Vietnam. These buildup problems put serious limitations on initial prosecution of the war. And throughout the war, the logistics system suffered from tremendous inefficiency, expense, and waste, which prohibited the US from waging a more intense campaign. We will begin by considering US plans to deploy combat forces to Vietnam.

Logistics Planning

Although contingency plans existed for military involvement in Vietnam, they proved to be futile in reality. Logistics plans

failed to prepare the US to deploy combat forces effectively. Logistics requirements were identified in plans which were “published as early as 1959 and revised in 1962 and 1963 . . . [However] action had not been taken to alleviate all the identified logistic shortfalls prior to the execution of combat operations.” (5:76) This assessment was made by Lieutenant General Joseph Heiser, Commander of 1st Logistical Command, Vietnam, and later DCS for Logistics of the Army. He specifically highlighted the lack of trained logistics personnel and adequate support organizations as prescribed by the plans. (5:76)

In a volume on *Military Logistics*, Air Force Institute of Technology (AFIT) Professor Emeritus Jerome Peppers states preliminary planning by the CINCPAC staff for supply support in Vietnam had “little operational relationship to need.” (7:248) Without realistic plans, trained personnel, or the organizations to provide combat support, the US was unable to efficiently and effectively insert military power into Vietnam. Thus, the problem of inadequate plans caused great difficulties in the initial buildup in Vietnam.

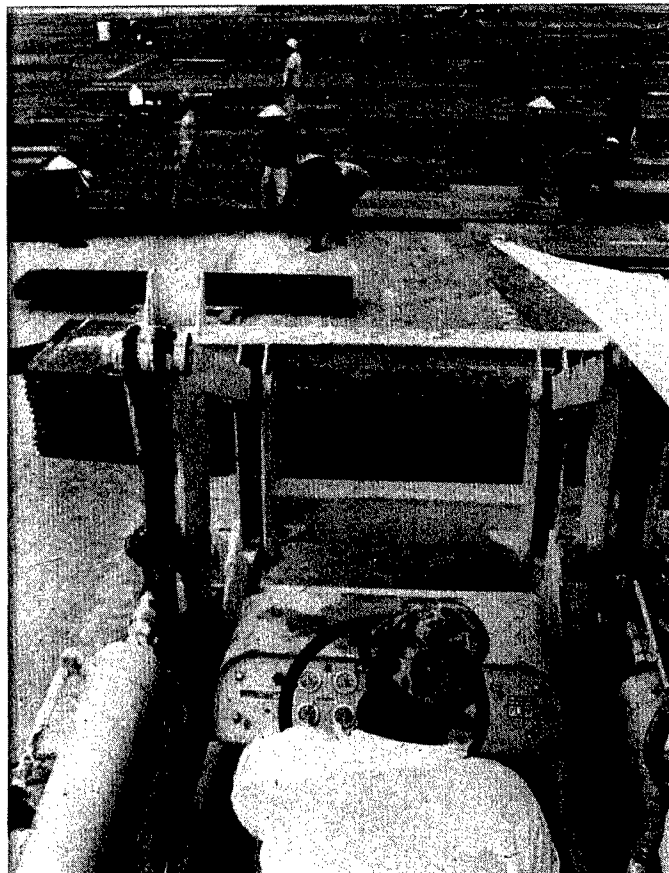

Buildup Problems

Problems with logistics plans were evident as soon as troops and supplies began to arrive in-country and persisted through several years of buildup. The buildup was disorganized and inefficient, delaying support for combat operations. The Secretary of Defense did not approve the initiation of a centralized logistics planning group until February 1965. (4:9) The same year, 150,000 troops arrived in-country. (8:232) A common practice was the "deployment of logistics support at the same rate as tactical units rather than in advance of them." (8:16) Also, procurement and delivery of equipment often lagged behind arrival of troops. (7:229)

Vietnam had essentially no national infrastructure for logistics use. (7:223, 9:152) Ports, transportation routes, and bases had to be built from little or nothing. This was an enormous undertaking for which the US lacked the plans or "on the ground" resources.

Problems facing logisticians were staggering and the lack of an overall plan for accomplishing logistics support was readily evident. For example:

Ships often had to wait in harbor for two or more months for offloading. Then, finally offloaded, supplies overflowed in the port shore facilities and could not be moved rapidly to point of storage or need. (7:240)

General Heiser's account further brings home the magnitude of this problem:

In the 1965-1966 time frame, as many as 100 ships with half a million tons of cargo stood off the Vietnam coast with no place to unload or store their cargoes. (5:77)

Furthermore, the official Air Force Logistics Command (AFLC) history notes that delays in expanding the base structure in Southeast Asia caused problems in sustained air operations and materiel support. (10:159-160) Construction requirements quickly exceeded the capacity of military forces, so reliance had to be placed on contract support. (7:265) The flood of construction materials further added to congestion at the ports. (7:239) Official records reveal:

Construction materials alone constituted some 40 percent of total tonnage of materials coming into South Vietnam in 1965 and 1966. (4:17)

Even AFLC rapid response teams sent to solve supply and maintenance difficulties during the buildup experienced a lack of basic support—housing, eating facilities, and transportation. (10:171) Continuing a chain reaction, problems in the buildup period plagued the combat effort in its early stages.

The Early War

These logistics inadequacies became a constraining factor in the early prosecution of the war. Major problems occurred with the supply of munitions. Initial procedures sent munitions from the US to the Philippines, then to forward bases in South Vietnam. The official Air Force history chronicles a system which took 150 days to get munitions from the US to the forward bases. (1:254) With 120-day reserves in the Philippines and 30 days at the forward bases, "a seven- to eight-month supply of munitions was often tied up in the supply pipeline." (10:166-167)

These inefficiencies eventually impacted combat operations. The use of B-52s in a major conventional role necessitated high usage of some types of munitions. The Secretary of Defense was advised in April 1966 that "munitions shortages were adversely affecting air operations." (6:259) In June 1966, the Joint Chiefs of Staff (JCS) directed CINCPAC to reduce sortie rates because

of air munitions shortages; this problem persisted until February 1967. (6:259-260) Munitions were not just an issue for the Air Force. General Heiser stated, "A balanced ratio of ammunition support units to units supported was not achieved until 1967." (4:122) And munitions were simply the most visible part of a larger supply problem.

Supply shortages and related problems affected other aspects of operations in Vietnam. For example, shortfalls in defoliant supplies and maintenance schedules delayed Operation Ranch Hand flights in 1966. (2:124) The widespread extent of supply problems impacting the mission is indicated by the "not operationally ready—supply" (NORS) rate for in-theater operations. The aircraft NORS rates in Southeast Asia exceeded Air Force averages (and the accepted standard of 5%) throughout 1965, 1966, and most of 1967. (6:253-256)

Finally, a 1980 Air War College analysis of Vietnam logistics documented "significant" shortfalls in the buildup period from 1965 to 1968 "in the process areas of resource allocation and distribution; in the functions of transportation, supply, and maintenance; and in the resource areas of equipment, personnel, supplies-mission, and procedural information." (8:96) Clearly, logistics constrained the early war effort. One must remember that the tide of public opinion turned against the war effort after the enemy's Tet offensive in 1968. What different result might have been obtained if the US had been able to support a larger, more effective effort prior to this time?

Long-Term Problems

Although the magnitude of these logistics problems lessened over time, many inefficiencies persisted throughout the war. Problems in munitions supply, for example, lessened in degree but persisted. Professor Peppers concluded, "Munitions became a major problem at times and a worrisome problem always." (7:252) Similarly, petroleum storage was a problem throughout the war, especially in the early years, and was much more expensive than necessary. (7:257)

Sources for war materiel were a continual problem. Industrial mobilization never occurred since there was no declaration of war or national emergency; furthermore, some manufacturers declined defense contracts because of public opposition to the war. (7:229)

Control of supplies and inadequate warehouse facilities also presented problems. Many supplies became unusable from storage outside in heat and humidity; in other cases, contents could not be identified because of weathering of packages.

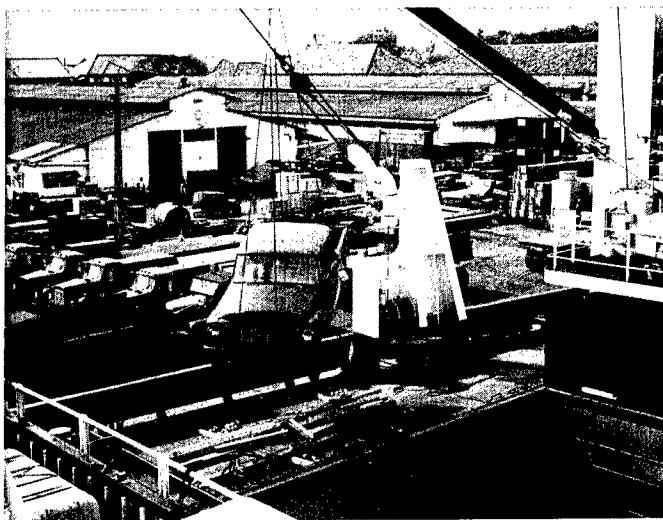

(7:224) Lack of security resulted in pilferage of up to 40% of items received. (9:170)

The policy of 12-month tours caused tremendous personnel turbulence and contributed to a persistent shortage of trained personnel. (4:255; 7:233) The support provided for personnel tended to be extravagant and added to the inefficiency of the war effort. Each unit determined its own standard of living and ordered from supply catalogs "as if they were Sears Roebuck catalogs." (4:17) So-called "morale supplies"—base exchange items, soft drinks, beer—put additional strains on the supply and transportation system. (7:249) Large exchanges, sports facilities, and air-conditioned housing increased construction requirements. Such practices also created tremendous inequalities in standards of living, with the actual combat troops benefiting least from these niceties. (7:276-277) These unnecessary accoutrements strained an already overburdened logistics system and actually reduced combat capability.

The logistics system which evolved in Vietnam was not only inefficient, but it made a larger or more prolonged combat effort unsustainable. In 1970, the House Committee on Government Operations concluded that logistics support of Vietnam operations had performed well but was marred by "appalling waste." (4:74-75) General Heiser concluded after the war that we had failed to apply "economy of force" to logistics, resulting in gross inefficiencies. (5:75) Vietnam logistics have often been characterized by lavishness and waste, violating principles of war such as objective and economy. (9:170) These flaws could have hampered operations and hurt the war effort had we not been "already pre-restrained politically." (9:170) Such evidence suggests the US is fortunate it did not have to discover how well it could support a bigger or more prolonged war effort.

An article prepared for the Air Command and Staff College curriculum concluded logistics could not support US military strategy, which was based on "overwhelming strength and firepower." (3:244) The author specifically faults leadership for failing to realize this limitation. Yet there are still many military leaders today who maintain that the secret to success in Southeast Asia was to do *more*—to take the war to the enemy in the North, to bomb Hanoi, to close the ports—not realizing that we might not have been able to do more with the forces and support available. The system had problems supporting an effort that ultimately led to withdrawal and defeat; it could not have supported a more intensified effort without significant changes.

Lessons Learned

This paper has examined logistics support in the Vietnam War and found that logistics constrained the war effort and contributed significantly to US failure. The US was not prepared logistically to project combat power to Southeast Asia, and we had much initial difficulty deploying to the theater. These problems clearly constrained early combat operations and resulted in long-term waste and inefficiency that limited a larger or more successful effort. All this evidence supports the conclusion that inadequate logistics played a significant part in the US failure to achieve victory. Although political factors restrained the military and ultimately led to our withdrawal from the conflict, logistics could not have sustained a winning effort without substantial changes in planning and execution.

What are the lessons we as logisticians should learn in order to prepare for the next time the US must project military power into a regional conflict? Many have written more detailed accounts which derive specific lessons within each functional

area. (4:255-263; 7:277-278) From this brief recap, some of the more significant lessons include:

(1) Our plans for contingencies around the world must include realistic logistics support requirements. Perhaps, more importantly, we must be sure to follow up on identified shortfalls in capability.

(2) Time phasing of logistics support and combat troops is critical to success. We must be careful to avoid deployment of troops with inadequate support. The logistics infrastructure must also be protected.

(3) Decisions must be made early about the relative permanence of facilities to be constructed. Over- or underestimating the length of US involvement (or simply ignoring the issue) creates tremendous inefficiencies.

(4) We must press our leaders to clearly establish a reasonable standard of living within the theater—one which is equitable but not a burden upon the supply and transportation systems. (8:228)

(5) Synchronization of logistics support and the tempo of operations is a must for combat effectiveness. This is a two-way street requiring constant communication between operators and supporters of the mission. (3:246)

(6) We must commit forces for the long haul if we enter a long-term theater conflict. Authors seem united in their condemnation of an established 12-month tour length in Vietnam, and rightfully so. (4:255, 7:278) It created tremendous strain on the personnel and training systems and decreased effectiveness because of continual turnover.

We would do well to learn these lessons, and many others which can be gleaned from our Vietnam experience, for our next conflict may not be as patient or as kind towards the US. As General Heiser has said so well:

Logistics lessons—both successes and failures. . . must be utilized to the fullest if the United States is to achieve maximum progress in the pursuit of that most essential logistics principle—Economy of Logistic Force. Readiness in the defense of the U.S. and its national goals demands no less. (5:80)

(The author gratefully acknowledges the comments of Cdr Bob Bushong, USN, of the Air Command and Staff College, and Mr Jerry Peppers, Professor Emeritus at the Air Force Institute of Technology, on an earlier version of this paper.)

References

1. Berger, Carl (ed). *The United States Air Force in Southeast Asia, 1961-1973*, Washington DC: Office of Air Force History, 1984.
2. Buckingham, William A., Jr. *Operation Ranch Hand: The Air Force and Herbicides in Southeast Asia, 1961-1971*, Washington DC: Office of Air Force History, 1982.
3. Carbon, Ron, Lt Col, USAF. "Logistics Support of the Vietnam War," *In Combat Support* (Vol 10), Maxwell AFB AL: Air Command and Staff College, 1990.
4. Heiser, Joseph M., Jr., Lt Gen, USA. *Vietnam Studies: Logistic Support*, Washington DC: Department of the Army, 1974.
5. Heiser. "Vietnam Logistics: Past is Prologue?" *Defense Management Journal* (July 1976), pp. 74-80.
6. Joint Logistics Review Board. *A Review of Logistic Support in the Vietnam Era*, Vol II of *Logistic Support in the Vietnam Era*, Washington DC: Government Printing Office, 1970.
7. Peppers, Jerome G., Jr. *Military Logistics: A History of United States Military Logistics, 1935-1985*, Huntsville AL: Logistics Education Foundation Publishing, 1988.
8. Quirk, John T., Lt Col, USAF. "An Analysis of Air Force Logistics Shortfalls of the Vietnam Buildup of 1965-68 as an Indicator of Shortfalls in Future Conflicts," unpublished research report, Air War College (AU), Maxwell AFB AL, 1980.

9. Rutenberg, David C., Lt Col, USAF, and Allen, Jane S. (eds). *The Logistics of Waging War*, Gunter Air Force Station AL: Air Force Logistics Management Center, 1987.
10. Termena, Bernard J., Peiffer, Layne B., and Carlin, H. P. *Logistics: An Illustrated History of AFLC and its Antecedents, 1921-1981*, Wright-Patterson Air Force Base OH: Headquarters Air Force Logistics Command, 1982.

(Since this paper was written, we have become involved in the Persian Gulf crisis. Below is a summary of some of AFLC's efforts so far to make Operation Desert Shield a logistics success. Perhaps, this time, we can avoid the mistakes we made in Vietnam.)

JL

Support for Operation Desert Shield



“AFLC has recognized quality as the single most important leverage we have for fulfilling our logistics commitment.”

— General Charles C. McDonald

Kelly AFB, Texas

2954th Combat Logistics Support Squadron
 JP-5 fuel
 C-5 aircraft accelerated depot maintenance
 Accelerated contract deliveries
 Communications circuits activated
 24-hour Personnel Readiness Center
 Locate, build and deploy munitions packages

Robins AFB, Georgia

2955th CLSS
 Medical workers
 Medical supplies and materials
 Air transportable medical clinics
 Chemical and nerve gas antidote agents
 Security Police Squadron

McClellan AFB, California

Civil Engineers' Prime BEEF team ready for deployment
 2952nd CLSS and aircraft engineers
 Maintenance surge
 Accelerate contract repairs and contract buys
 Spare parts and war readiness kits for F-117A
 Supply pallets shipped

Newark AFB, Ohio

Deployment of FASTCAL, calibration laboratory
 Maintenance surge

Hill AFB, Utah

Maintenance surge for aircraft parts
 Accelerate buys and repairs
 Direct parts buys from General Dynamics, F-16 aircraft
 F-4 spare parts
 More than two million pounds of material shipped
 Locate, build and deploy munitions packages
 4th Tactical Fighter Squadron
 2849th CLSS
 711 wills prepared
 3,037 powers of attorney prepared

Wright-Patterson AFB, Ohio

Air transportable medical clinic
 Medical center support teams
 401st CLSS

Tinker AFB, Oklahoma

Around-the-clock distribution support
 War-readiness support kits
 Built shipping
 Air terminal surge
 2953rd CLSS
 Accelerated maintenance

Using Goal Commitment to Improve Performance

Captain Randal A. Gescheidle, USAF
Deputy Program Manager
Advanced Weapons Directorate
AF Weapons Laboratory
Kirtland AFB, New Mexico 87117-5000

Major Kenneth R. Jennings, USAF, Retired
PACER Group
5011 Strathaven Drive
Dayton, Ohio 45424

Introduction

Goal setting is a common occurrence in many Department of Defense (DOD) organizations. Year after year, commanders at all levels issue their organizational goals, often using inputs from subordinates. Perhaps, some organizations use these goals as a check to evaluate their performance, effectiveness, or efficiency. Others may simply discard them—after all, no one really uses goal setting to improve performance. Some experts would argue, however, that goal setting is an integral part of motivation (8) and innovation which can lead to improved performance which, in turn, can be evaluated in terms of improvement in quality, customer satisfaction, and turnover.

Consider for a moment that goal setting does, in fact, make a significant difference to the organization's well-being and that improvements in performance, efficiency, or effectiveness usually result. Further, consider that goal setting is no respecter of organizational type (private versus public, profit versus non-profit). With these basic assumptions, the organization that chooses to set goals as a means of achieving an end should also understand how to obtain a high level of commitment to those goals. Some leaders may have thought that goal commitment "just happened" with the act of setting goals or results because of a person's charisma. But, the following arguments show that improved performance through goal commitment does not "just happen." Instead, goal commitment and, thus, improved performance can be virtually assured by following the steps given at the end of this article. But, first, let's see how we arrived at these goal commitment "determinants" by defining and discussing the importance of goal commitment. Then, we will describe a common problem in obtaining goal commitment, discuss the common goal-setting techniques; and, finally, provide some hints that leaders can use to obtain goal commitment.

Definition of Goal Commitment

Researchers have explored many antecedents to "goal commitment" without, first, formally defining the term. (5; 4) Others used goal acceptance and goal commitment interchangeably. (1; 2; 3) The lack of a formal definition has led to the use of a more generally accepted, less formal definition. We will forego the dissertation on goal commitment definition and adopt the less formal definition. Therefore, we define goal commitment as the determination of a person or groups of people to achieve a goal or a set of goals. The reader can compare definitions from other researchers such as Locke, et al (8; 9) and Hollenbeck and Klein (4).

Why Is It Important?

Having established a need for goal commitment, the next step is implementing changes that cause or encourage a commitment to the goals. Unfortunately, this step has generally not been available to commanders. In fact, until recently, this step has been omitted. And, now, with budget deficits and negative defense budget growths becoming a part of our business environment, obtaining a commitment, which leads to improved performance, becomes increasingly more important to many Air Force organizations.

Problem Statement

Earlier, we stated that organizations must, among other things, be innovative to keep pace in today's market. Although solutions

are often offered to profit motivated organizations, non-profit organizations also have reasons for wanting to institutionalize innovation. For example, DOD is experiencing what is surely to become accepted practice—*having less resources to do the same mission*.

For example, a portion of the Air Force Logistics Command's (AFLC) mission is performing major overhauls on existing weapon systems. A "system" can range from an aircraft, such as the F-15, to the avionics on the aircraft, to the "black boxes" that collectively form the avionics system. The Air Logistics Center responsible for maintaining that system may need to improve productivity because of the shrinking defense dollar.

One method to increase productivity, logically, is improving the manner in which the tasks are completed—improving productivity through innovation. Obviously, other interactions must work in harmony: using technology, task design, etc. However, innovation can occur by obtaining a commitment to the organization's goals.

Major Jennings, in his address to the 93rd Annual Quality Congress of the American Society for Quality Control, discussed the "processes" of making innovation successful. (6) Goal setting is one process; obtaining goal commitment ensures that incremental innovation is successful.

Types of Goal-Setting Methods

Most researchers have tested hypotheses based on three types of goal-setting methods:

(1) *Self-set goals*. When workers are left to set their own goals, the results may not be very challenging and as such are not in the best interest of their organizations. (10:462) This is commonly referred to as the "do your best" technique. It assumes the worker is motivated. In our research, references to this method are generally for comparison only. The remaining two methods offer more of a challenge to research, but, more importantly, are instrumental in motivating people.

(2) *Participation*. Participation is a goal-setting technique that involves both supervisors and subordinates. It allows subordinates a say in the goals that directly affect their tasks. But, it also allows supervisors some control in ensuring that acceptable goal levels are set. But, participation has both advantages and disadvantages. It is the most time-consuming goal-setting technique since it requires acceptance by both supervisors and subordinates. The supervisors meet with the subordinates to discuss the organizational goals. They seek to gain the subordinates' acceptance or commitment to as many goals as possible. Of those goals where no commitment is made, the supervisors then seek to "negotiate" their acceptance. But, therein lies the strongest point—goals accepted by the subordinates tend to be accepted as their own. This may result because employees increase their awareness of the organizational "big picture." (7) Consequently, an increased effort to attain the goals is possible and, in fact, likely.

But, participation has limits management should consider. First of all, for many, performance is virtually unaffected by accepting goals. Secondly, participation may be less effective than assigned goals for those goals which were negotiated. (10:462)

(3) *Assigned goals*. An assigned goal is directed by leadership with little or no input from the subordinates. Of the three, assigned

goals offer the best opportunity for the organization to prosper (in whatever fashion prosperity may be defined). However, assigned goals are only effective if the workers are willing to accept them. Thus, a limitation of assigned goals may lead to a lower commitment than participatively set goals. (10:462-463)

Which technique works best? It depends on time constraints or whether or not a particular goal can be negotiated. The important point is that goals are, in fact, set and used, continuously monitored, evaluated, and measured.

Goal Setting

We suggest that goals should be both attainable and practical. As a leader, practicality and attainability should be balanced with difficulty. Therefore, the first step a leader should take is to determine reasonable goals.

The next step depends on the type of goal-setting method the leader chooses. If possible and time permitting, goals should be participatively set. When this method is used, ambiguous goals can be identified and cleared, alleviating future problems. Also, as mentioned earlier, participatively set goals help people feel much more a part of the organization.

Once the goals are finalized, regardless of the type of goal-setting method, the goals should be publicized. This act broadcasts to the world what the organization "signs up" to accomplish. Publicizing goals can range from posting them in conspicuous places, to "spreading the word" to the MAJCOM or the next higher headquarters.

Finally, leaders should provide continuous feedback to their people. Feedback is crucial in order to successfully attain the established goals. Not only does it update people on the organization's progress, but it allows them to tell the leaders about problem areas that are preventing goal attainment.

Practical Program Ideas for Managers and Commanders

Using a final goal commitment model as a reference, several options are available to supervisors and commanders to obtain a commitment to their organizational goals. However, a precursor to goal commitment, as mentioned earlier, is the establishment of goals.

Rewards. Reward programs are important and are an integral part of most organizations. Most programs, however, reward workers for a certain performance and not necessarily for helping the organization attain specific goals. This is not to suggest that these programs be abandoned, but, rather, enhanced to include rewards for goal attainment. Obviously, organizations can institutionalize programs with as much or as little funds as necessary. But, how much is spent is secondary to having a good, management-backed program. Reward programs can be set up so personnel are rewarded on a period, job, or per goal basis.

Employees rewarded on a periodic basis have specific milestones or checkpoints, established when the goals were set, where progress is checked. This particular program works well for tasks or projects where uncertainty and high costs dominate. For example, a goal might be to complete 30% of the project in the next quarter. The supervisor provides feedback biweekly so adjustments can be made as needed; and, at the end of the period, the goals are evaluated. If successful, the team is rewarded. Rewards can range from a meager pay raise, time off, or special recognition at a unit function. If the company has no function scheduled within that period, schedule one.

Self-efficacy. This factor is more complex and, consequently, more difficult to address. The difficulty results because, by definition, self-efficacy is an internal mechanism. It is the worker who must acknowledge the ability to attain the organizational goals. However, there may be some actions leaders can take to encourage their subordinates.

One of the more useful techniques is the feedback program. Obviously, this depends heavily on the type of organizational

structure; but, for the most part, continuous feedback is helpful in getting the worker to "see" goal attainment.

Trust. Trust is an action that begins with the manager, the supervisor, or the commander—the leader. Trust influences goal commitment when the worker knows the leader can be trusted and the worker is confident in that trust. Gaining that trust is also an individual program. For instance, we have seen leaders, in order to gain trust, give a particular project to an individual. Now, the project was selected based on the confidence the leader had in this person; in this case, a little more difficult than other projects. Then, the leader held that individual responsible AND gave her the authority to complete the task. That person gained her supervisor's trust because she was responsible for her project. (NOTE: Obviously, other social interactions are occurring, and this somewhat simplifies the synergistic effects; but the point should be made that gaining trust increased goal commitment.)

Expectancy. Like self-efficacy, this influence is determined by the workers and how well or how much they can expect from commitment to organizational goals. However, in order for those workers to raise their expectations, programs or incentives must exist for the workers. In other words, workers tend to look for programs that lead to promotions; pay raises; increases in skill level; perhaps, even autonomy in tasks; as well as decision making. Therefore, it is incumbent upon leaders to institutionalize incentives to ensure their reasonableness and attainability. Otherwise, the programs become meaningless in the eyes of the workers who may reject the goals to which they were previously committed.

Competition. Since this factor in some cases negatively impacts goal commitment, it deserves special consideration. This effort researched competition in the context of competing work teams, shifts, or departments. Since it negatively impacts goal commitment, the leader should be wary of instituting programs which promote competition and, thus, inhibit goal commitment.

Conclusion

The suggested programs are intended to assist commanders in obtaining a commitment to their organizational goals. It would be difficult to design, in this effort, all possible combinations of programs which would achieve these ends. However, the recommendations in this paper provide sufficient information for the leader to institutionalize goal commitment programs.

References

1. Earley, Christopher P. "Influence of Information, Choice and Task Complexity Upon Goal Acceptance, Performance and Personal Goals," *Journal of Applied Psychology*, 70 (August 1985), pp. 481-491.
2. Earley, "Supervisors and Shop Stewards as Sources of Contextual Information in Goal Setting: A Comparison of the United States with England," *Journal of Applied Psychology*, 71 (February 1986), pp. 111-117.
3. Erez, Miriam, et al. "The Impact of Participation of Goal Acceptance and Performance: A Two Step Model," *Academy of Management Journal*, 28: (March 1985), pp. 50-66.
4. Hollenbeck, John R., and Klein, Howard J. "Goal Commitment and the Goal-Setting Process: Problems, Prospects, and Proposals for Future Research," *Journal of Applied Psychology*, 72 (May 1987), pp. 212-220.
5. Hollenbeck, John R., et al. "An Empirical Examination of the Antecedents of Commitment to Difficult Goals," *Journal of Applied Psychology*, 74 (February 1989), pp. 18-23.
6. Jennings, Major Kenneth R. "Continuous Quality Improvement: A Proposed Research Model," address to the 93rd Annual Quality Congress of the American Society for Quality Control, Montreal, Canada, 1989.
7. Latham, Gary P., and Saari, Lie M. "The Importance of Union Acceptance for Productivity Improvement Through Goal Setting," *Personnel Psychology*, 35 (Winter 1982), pp. 781-787.
8. Locke, Edwin A., and Latham, Gary P. *Goal Setting: A Motivational Technique That Works*, Englewood Cliffs, NJ: Prentice-Hall, 1984.
9. Locke, Edwin A., et al. "Effect of Self Efficacy, Goals and Task Strategies on Task Performance," *Journal of Applied Psychology*, 69 (May 1984), pp. 241-251.
10. Oldham, Greg R. "The Impact of Supervisory Characteristics on Goal Acceptance," *Academy of Management Journal*, 18 (September 1975), pp. 461-475.



Petroleum Support in PACEX III

PACEX III was the third in a series of U.S. Pacific Command (USPACOM) war games. The focus of PACEX I was operations and PACEX II looked at changes in basic OPLAN assumptions to see the effects on execution. In PACEX III, the operators and logisticians examined the logistical supportability of OPLAN 5000. The logistics play was as detailed as possible, consistent with limitations of data, simulation techniques, and time available. The objectives for this analytical war game were to review materiel availability, logistics command and control, inter/intratheater lift, logistics infrastructure, and medical support issues in the USPACOM area of responsibility. All these issues are key to carrying out the USCINCPAC warfighting strategy. Fiscal constraints and force structure changes now and in coming years will present tough challenges to both the logisticians and operators. This reason made it even more important to critically analyze the logistical supportability of OPLAN 5000.

While details of this analysis are classified, the methodology and many of the insights gained are not. The purpose of this article is to share this information as it relates to petroleum, oil, and lubricants (POL) support. Petroleum support to joint forces was analyzed through time as the scenario unfolded with detailed inventory modeling. While the spectrum of logistics activity took place simultaneously, tracing petroleum support from womb to tomb will provide a comprehensive review. It is important to realize the POL problems did not surface sequentially, since the following activities were all happening, somewhere, sometime, throughout the war game.

The first step in POL support is crude oil production. While not a military activity, production and refining are important military considerations. Prior to PACEX III, we reviewed numerous studies and conducted some of our own to review the sourcing to be used. This review concluded that enough crude oil would be available to the anticipated refinery base to meet production demand. Several excursions were made to determine changes in the level of risk if crude oil sources and refineries were denied. While the conclusions reached are scenario dependent, the following general observations are consistent for most. Secure sourcing of industrial base requirements is preferred. Many factors govern how secure a source is considered to be. Not all crude sources are reliable. The Defense Production Act covers only U.S. refineries. Not all refineries can make military specification products, most notable JP5. Crude oils have different refinery yields of various fuel grades. Some refineries can convert one fuel grade to another or handle problem crudes with high sulfur content. Some friends and allies can be considered unreliable in terms of wartime supply (in some cases a matter of cannot as opposed to will not help.) All these factors must be considered. Then an assessment of supply versus demand is made. The level of risk is evaluated in selecting sources necessary to meet demand.

The most secure and on-time delivery source is war reserve materiel (WRM) prepositioned at the point of intended use. The only problems with prepositioned WRM are it costs money to buy and store it in peacetime and the enemy considers it a prime target. As a result the total wartime requirement is met by a combination of WRM and resupply. Any peacetime operating stocks (POS) available at the outbreak of hostilities are a plus-up. POS varies from day-to-day and can be drawn down by a fuels crisis or other non-war event.

Since the fuel must be moved to the requiring unit, there is an interplay between supply and transportation. Normally, one seeks predominantly secure sources and then does the lift evaluation. If required stocks can move on time, the interplay ends. If not, less secure sources are used and reevaluated until the best tradeoff between on-time delivery and secure sourcing is reached.

Fuel can be transported by sea, land, and air. In PACOM the sea leg is predominant. The number, size, draft, and availability of tankers and barges impact delivery capability. Having gotten the ship across the ocean is not enough. If it has too deep a draft to get into the port or there is no port, ship arrival does no good. Storage is needed to offload the fuel into, as is a way to get it from ship to shore. This means looking at piers and hose lines. The capability to discharge a complete cargo is desirable. Multi-porting a ship increases its delivery cycle time. One should also realize that multiple fuel grades complicate the process.

Land transport can be as simple as a port to a nearby base via pipeline or as complicated as a multi-modal system involving truck and rail. This would also involve host nation support plus command and control considerations. In-land distribution is normally an Army mission and is covered in FM 10-67. This process would require an entire article in itself to address adequately. Fortunately, many of the historical lessons learned have been well documented and the axioms developed in operating the World War II "Red Ball Express" remain true today.

While it is possible to airlift bulk POL, doing so is inefficient and as a rule of thumb uses a gallon of fuel to deliver two gallons. War sometimes calls for inefficient means to produce effective results. Airlift is still the primary means of resupply to units cut off by enemy action or to allow an advance not otherwise supportable.

Having traced the flow of fuel, it is important to cover three areas that impact this flow: quality control, accounting, and reporting. Keeping the right fuel means it is usable for its intended purpose. Quality control ensures that the fuel meets military specifications. This requires that proper procedures are followed and that the fuel is sampled and tested. While the requirements of peacetime financial accounting can be relaxed in combat situations, the need for knowing how much is available remains. This is tied to the reporting system which allows resupply to be intensively managed. Despite the fact that PACEX III was not a "fuel crisis," high level interest was constant throughout the exercise regarding the status of bulk petroleum.

In conclusion, the analysis of petroleum support in PACEX III resulted in both significant classified findings and, perhaps more importantly, a methodology to examine petroleum support comprehensibly. While deliberate planning is as broad in scope and normal Command Post Exercise play is as detailed in problem solving, never before have all aspects of joint petroleum support been minutely examined to the extent they were in PACEX III.

Lieutenant Colonel John Gavel, USAF
Chief of the USPACOM Joint Petroleum Office
Camp H. M. Smith, Hawaii 96861-5025

Winter Issue—

- *An Air Bridge to Tel Aviv*
- *The Poet Revealed: A Future for Human-Centered Design*
- *Logistics Support of Votkinsk Portal Facility*
- *Supportability Investment Decision Making*
- *Termination of Federal Construction Contracts*

And More