

02 DEC 1987

AFLMC TECHNICAL  
REFERENCE LIBRARY

20040601 072

# AIR FORCE JOURNAL *of* LOGISTICS

**DISTRIBUTION STATEMENT A**  
Approved for Public Release  
Distribution Unlimited

**FALL  
1987**



**CAN WE SURVIVE . . .  
AND WIN?**

AFRP  
400-1

VOL XI  
NO 4

# AIR FORCE JOURNAL <sup>of</sup> LOGISTICS

## CONTENTS

FALL  
1987

### ARTICLES

- 1    **SPECIAL**    **Adding "CLOUT" to Logistics**  
Colonel Albert M. Ramroth, USAF
- 4    **SPECIAL**    **Project RELOOK: The Case for Base Self-Sufficiency**  
Lieutenant Colonel Thomas C. Nettles, USAF
- 8    **Unprepared for War: Aviation Logistics and The Home Front, 1917-1918**  
Robert P. Smith
- 13    **Assessing Strategic Airlift Aircraft in WSMIS**  
Carol Schweiger
- 18    **Power Projection Through Airlift—How To Make It Work**  
Major David F. Todd, USAF
- 22    **Military Construction: Time for a Change**  
Colonel Donald J. Thomas, USAF
- 27    **Meeting USAF Civil Engineering Customer Expectations**  
Captain Max E. Kirschbaum, USAF
- 29    **Can We Win the War With What's on our Flight Line?**  
Captain Gary L. Gemas, USAF
- 34    **An Expected-Value-Based Logistics Capability Assessment Model (ELCAM)**  
Major Roy E. Rice, USAF

### DEPARTMENTS

- 16    *USAF Logistics Policy Insight*  
31    *Career and Personnel Information*  
38    *Logistics Enquirer*  
40    *Logistics Warriors*



Honorable Tidal W. McCoy  
Assistant Secretary of the Air Force  
Readiness Support

General Alfred G. Hansen  
Commander  
Air Force Logistics Command

Lieutenant General Charles C. McDonald  
Deputy Chief of Staff  
Logistics and Engineering, HQ USAF

Colonel Albert H. Smith, Jr.  
Commander  
Air Force Logistics Management Center

#### Editors

Lieutenant Colonel David M. Rigsbee  
Jane S. Allen, Assistant  
Air Force Logistics Management Center

#### Graphics

Ms Peggy Greenlee

(The photo featured on our Spring 1987 cover was taken by David Williams instead of Robert Martin.  
We extend our thanks for a superb product.)

- 
- Purpose**    The *Air Force Journal of Logistics* provides an open forum for the presentation of issues, ideas, research, and information of concern to logisticians who plan, acquire, maintain, supply, transport, and provide supporting engineering and services for military aerospace forces. It is a non-directive, quarterly periodical published under AFR 5-1. Views expressed in the articles are those of the author and do not necessarily represent the established policy of the Department of Defense, the Department of the Air Force, the Air Force Logistics Management Center, or the organization where the author works.
- Distribution**    Distribution within the Air Force is F. Customers should establish requirements through the PDO system, using AF Form 673a, on the basis of 1 copy for every 5 logistics officers, top three NCOs, and professional level civilians assigned. If unable to use the PDO system, contact the editor. *AFJL* is also for sale by the Superintendent of Documents, U.S. Government Printing Office, Washington, D.C. 20402. Back issues are not stocked.
- Manuscripts**    Manuscripts are welcome from any source desiring to deepen or broaden the knowledge and understanding of Air Force logistics professionals. They should be typed (double-spaced) and be between 1500-3500 words. Figures, graphics, and tables (separate pages) should be numbered consecutively within text (Address: AFLMC/JL, Gunter AFS AL 36114-6693; AUTOVON 446-4087, Commercial (205) 279-4087).
- Refereeing**    *AFJL* is a refereed journal. Manuscripts are subject to expert and peer review, internally and externally, to ensure technical competence, correct reflection of stated policy, and proper regard for security.

## Adding "CLOUT" to Logistics

Colonel Albert M. Ramroth, USAF

Director, CLOUT Program Office

DCS/Plans and Programs

HQ AFLC, Wright-Patterson AFB, Ohio 45433-5000

*Editor's Note: The following articles on "CLOUT" and "RELOOK" report on recent research into USAF's ability to meet its logistics support requirements, particularly in light of increasingly difficult scenarios in Central Europe. Some of the ideas presented are included in a new Logistics Concept of Operations which will form the framework for future logistics planning in the USAF. The new Concept of Operations was briefed at the recent LG conference at Kadena AB and will be presented to our readers in a special article in the Winter issue of the Journal.*

The Air Force knows that a high-intensity, non-nuclear conflict may be the type in which it will find itself in the future. Studies and the playing out of realistic conventional wartime scenarios over the past few years point out the time is at hand to examine the capability to respond and succeed in such a situation. The Air Force is attacking this on several fronts.

### Objective and Response

As has always been the case, logistics is the primary player in sustaining a combat force. *Placing the right resources at the right place when they are needed* has been the logistic objective since the caveman started throwing rocks. However, in examining how logistics is configured to sustain combat forces, some "tired and true" assumptions recently have been questioned; the results of this examination are troublesome and suggest the need for change. There are certain assumptions and facts that lend a great deal of credibility to the realization that perhaps we are not correctly configured to sustain a conventional, high-intensity conflict. There are also some answers to the perplexing problems, but they are not without complexity. One of these answers is a logistic operating concept appropriately named CLOUT—*Coupling Logistics to Operations to Meet Uncertainties and the Threat*.

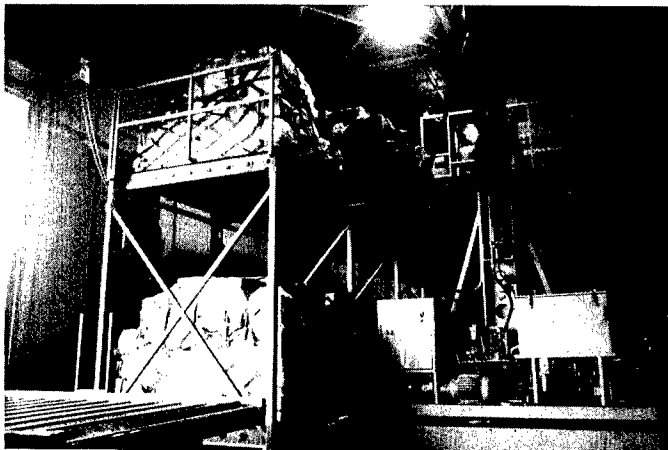

WRSK ready for deployment.

The Air Force has for many years operated under the assumption that it would fight a conventional conflict relying on organic capabilities at forward bases augmented with personnel; war readiness materiel (WRM) contained in deployable war readiness spares kits (WRSK); and increased levels of assets at forward bases, known as base-level self-

sufficiency spares (BLSS), for aircraft that fight in place. These assets are configured to last for the first 30 days of war, at which time replenishment from the rear would then satisfy demands for not only spares, but munitions, fuel, and rations. The Air Force also believed its bases would be relatively safe from major damage and capitulation. This belief followed the assumption that its forces were superior—if not numerically at least qualitatively—and could fend off an aggressor. Both the capability of the air base to maintain its integrity (demonstrated during the SALTY DEMO exercise in 1985) and the reliance on WRM to sustain the combat force have come under serious review in recent months. Reconfiguring bases to ensure their survival has recently received high-level attention—in the wake of "Project RELOOK." However, while base vulnerability is certainly a factor that drives a closer examination of logistics support in war, the focus is on the advisability of continuing to rely so heavily on WRM as the major means to sustain the Air Force's warfighting capability under the assumption that we have adequately predicted the scenario, conditions, and enemy responses. And, if our reliance is questionable, then what?

***"Rand examined the current logistics support system and found it limited in its ability to cope with the unplanned and dynamic events surely to be encountered in war."***

The Rand Corporation, under PROJECT AIR FORCE, examined logistics responsiveness in a study entitled *Enhancing the Integration and Responsiveness of the Logistics Support System to Meet Wartime and Peacetime Uncertainties*, of which the short title was *The Uncertainty Surrounds War*. Rand examined the current logistics support system and found it limited in its ability to cope with the unplanned and dynamic events surely to be encountered in war. With respect to aircraft spares, highly variable demand rates, particularly in light of battle damage and dynamic flying requirements, make any predictions extremely difficult, if not impossible. Currently, the Air Force configures WRM levels based on what it considers will be known and predictable conditions. An earlier Rand study, *Driving Inputs and Assumptions of Stockage and Assessment Models (DRIVERS)*, focused on serious demand variability problems with a small number of problem parts identified by the Tactical Air Command (TAC). Demands were found to fluctuate dramatically and this "moving target" made the prediction of

(Col Ramroth is presently a student at AWC, Maxwell AFB AL.)

accurate stock levels extremely difficult. Demand variability alone appears to have a dramatic impact on aircraft availability. If demand variability is coupled with environmental uncertainties, mission capable rates decline rapidly. A seemingly easy answer to the problem might be to increase levels; but even if this were fiscally possible, which it is not, there would still be no certainty that the correct mix could be attained. Other Rand and Air Force studies point to the same problem of demand uncertainty, and there is nothing on the horizon that has the potential to improve our ability dramatically to forecast requirements accurately. Thus, we are left with the double-edged problem of dealing with both demand and environmental uncertainty that could seriously degrade combat capability.

## CLOUT Concept

An outgrowth of the Uncertainty Project was a logical shift by Rand to examine methods of changing the logistics system to make it more responsive to real-time operational requirements. This led to the formulation of the CLOUT concept which truly does "Couple Logistics to Operations to Meet Uncertainties and the Threat."

CLOUT is a logistics concept of operations that proposes directly linking both theater and depot logistics capabilities to real-time operational requirements in peace and in war. It reconfigures logistics so it is flexible and responsive and is not frustrated by the uncertainties and dynamics encountered in war. It is important to note that CLOUT is *not* a system in the sense that it is a new network of data processing equipment that "pulses" the logistics system and manipulates it to satisfy changing requirements. Rather, it is a concept of operations that builds on existing systems and changes them to be more responsive. And, although the initial focus of the CLOUT project is on repairables—specifically avionics repairables because of the high payoff—the concept of CLOUT certainly applies to other commodities such as munitions or fuels.

CLOUT proposes changing logistics procedures in both the theater and the depot to handle operational demands more responsively in peace and in war. To improve response to operational requirements, CLOUT places as its objective the goals of the theater commanders—expressed as aircraft availability goals (fully mission capable aircraft) and near-term flying hours. That is, it will be the responsibility of the theater commanders to prioritize those aircraft at bases under their control in relation to their expected future mission requirements. In addition, information is needed on asset status at each base. These are the essential elements of information that will drive the total (base and depot) logistics support system. In the case of a multiple theater war, it will be incumbent upon a higher authority to determine theater precedence. This information will be passed over a Combat Support Command, Control, and Communications (C<sup>3</sup>) system to both theater and depot decision support systems so the proper logistics responses can be made (see Tripp article, "Strategies for Logistics C<sup>3</sup>I," *AFJL*, Spring 1987). It would seem appropriate, initially, to task the theater logistics capability first to respond to the operational requirement—and this is mainly because of its proximity. In this case, the theater's decision support system, which has visibility over theater assets and capabilities, would suggest to the logistician the smart decision to direct movement of assets from one base in theater to the one which has been identified as having near-term importance. In the event that the asset is not readily

available in theater, then the decision support system would direct that an in-theater maintenance shop repair the item and would even direct the carcass to that shop for immediate repair. An algorithm for prioritizing repair and distribution in the maintenance shop which responds to operational goals would be a tremendous asset. In fact, just such an algorithm exists today and is being field-tested in several F-16 avionics maintenance shops at Ogden Air Logistics Center, Hill AFB, Utah, and is scheduled to be further tested for theater repair and distribution decisions at the Pacific Logistics Support Center, Kadena AB, Japan.

It is obvious in this scenario that assured, redundant in-theater transportation and communications are essential. Though they do not exist today, they must be planned. The European Distribution System (EDS) already has aircraft dedicated to the movement of logistics assets, and it must continue in that role in wartime. The Pacific Distribution System (PDS) has considered wartime tasking and volume needs in establishing its airlift requirement. Both of these systems must be included in the theater Combat Support C<sup>3</sup> link for them to be successful. CLOUT provides the framework and dictates the requirement for both transportation and communications. However, the CLOUT concept does not dictate a specific maintenance configuration for a theater. In other words, the CLOUT concept can be applied to a centralized or dispersed rearward maintenance configuration or a forward configuration. Initial indications are there is a great deal to be gained from some degree of centralized theater maintenance for certain kinds of items; but vulnerability, geographical, political, and other considerations must go into the formula in determining theater maintenance configuration.

***"The ALC, with all its tremendous capabilities, is not now considered a prime player until after the initial 30 days of a conflict. This must be changed!"***

To complete the concept, the stateside air logistics centers (ALCs) must be added to the equation to further couple *all* logistics to operations. The ALC, with all its tremendous capacities, is not now considered a prime player until after the initial 30 days of a conflict. This must be changed! There are monumental benefits that can be derived by involving the ALCs as early as possible. The change that must be brought about makes the ALCs responsive immediately at the onset of hostilities and makes them real partners of the operational commander. To do this, the ALCs must reconfigure their methods and priorities in response to what is needed on the first day of a conflict and adapt to changes on each subsequent day. The CLOUT concept provides a way to achieve this flexibility, by coupling maintenance, distribution, and transportation to the same operational needs already discussed—the theater commanders' prioritized lists of aircraft and bases under their control in relation to anticipated future mission requirements. Relying on the present mission capability (MICAP) methods of responding to immediate needs only marginally suffices in peacetime and certainly will not suffice in a high-intensity, dynamic conflict, merely because of the volume of demands anticipated.

Operating ALCs in a responsive flexible manner will achieve this goal. It depends on solving some tough problems

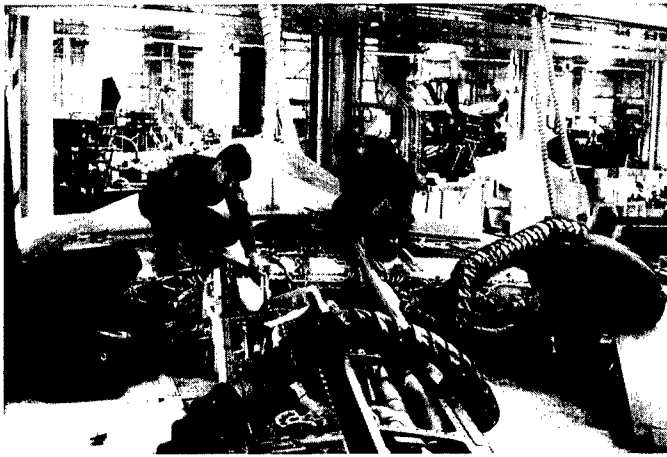

F-16 depot maintenance facilities must be integrated into the war effort in the early days of conflict.

concerning prioritization of weapon systems and moving information. But it is achievable! This mode of operation must become the routine operating procedure in peacetime so that it already exists in wartime. An extremely promising demonstration of this concept and capability is presently underway at the Ogden Air Logistics Center. There, three F-16 Avionics shops are prioritizing repair of avionics parts in response to aircraft availability goals; subsequently, item managers are distributing these parts to attain the goals. Initial results are very promising. More importantly, however, this demonstration points directly at the associated data systems, policies, procedures, and methods that will have to change to accommodate this new concept. In addition, the demonstration clearly shows that present procedures are not nearly as responsive to operational requirements as they could or should be.

***"To satisfy this problem, assured logistics transportation of key wartime assets must be acquired and not tampered with at the onset of hostilities."***

One obvious problem that immediately comes to mind in dealing with this concept is the large distance between theaters and depots. To satisfy this problem, assured logistics transportation of key wartime assets must be acquired and not tampered with at the onset of hostilities. This transportation must satisfy both inter- and intra-theater requirements, and it can be either organic or contract as long as it satisfies the need. As mentioned, it appears that both the EDS and PDS transportation fleets have been sized to do the job (at least for critical repairables), but this must be verified. The intra-theater requirement has been preliminarily sized, and it appears that the distribution requirement could be satisfied

with a few wide-bodied transports cycling between the theater and the CONUS for the first 30 days of a conflict.

## **An Overarching Logistics Concept**

What is defined here is an idea that immediately brings the total logistics capability to bear on a conflict when the conflict begins. That is a capability that we do not presently possess.

***"As this concept ripples out, it gives direction to the entire spectrum of logistics both in the theater and at the depot."***

What it dictates, if this end is desirable, is that we change and adapt. We must change logistics methods to be responsive to operational requirements in the near-term; change the way we compute requirements; change the way we measure maintenance effectiveness; change the way we distribute assets; adapt data processing techniques; change transportation methods and priorities; and change and adapt about every way we traditionally have done business. It becomes clear, as this concept ripples out, that it gives direction to the entire spectrum of logistics both in the theater and at the depot. It is in fact the seamless logistics process for which we are searching, and it is the yardstick that should be used to measure the worth and effectiveness of new logistics systems, procedures, and policies.

## **Present Status of CLOUT**

The Directorate of Logistics and Engineering, HQ USAF, has chartered a General Officers Steering Group to investigate both theater and depot initiatives that will determine the feasibility and advisability of CLOUT in the Air Force. This group has three major components: USAF/LEY serves as the Depot-Theater Coordinator responsible for ensuring that initiatives in both areas make sense, mesh, and are consistent; AFLC/XR, the Depot Coordinator, is responsible for depot initiatives; and USAFE/LG, the Theater Coordinator, is responsible for theater initiatives. AFLC/XR created a CLOUT Program Office which is acting as the stimulus for CLOUT-related initiatives both within and outside AFLC, is conducting feasibility tests of aspects of the concept, has written an action plan which outlines specific changes required to bring the concept to reality in AFLC, and is coordinating functional efforts in the Command. Dialogue among and within major commands on this concept is just beginning. Implications for changing many logistics functions are far-reaching and necessitate a broad array of solutions which have both planning and program implications. In the final analysis, the concept, though perhaps complex and difficult to realize, has monumental payoffs for the operational Air Force. **AJY**

## **DPML Update**

The authors of "View from the DPML: Performance and Supportability" (AFJL, Summer 1987) report that, since their article was first written in 1986, significant strides continue to be made in strengthening the role of the DPML in the development and acquisition process.

---

---

## Project RELOOK: The Case for Base Self-Sufficiency

Lieutenant Colonel Thomas C. Nettles, USAF  
Director of Supply  
Air Force Logistics Management Center  
Gunter AFS, Alabama 36114-6693

---

---

The airfield environment in a central European war will be characterized by heavy and sporadic attacks, with severe damage to runways, taxiways, unhardened facilities, communication networks, and utility systems. Communication and transfer of logistical information will, at unpredictable times, be virtually impossible due to a combination of attack damage and saturation. Due to battle damage, sabotage, and infiltration by trained agents, sympathizers, and operational maneuver groups, physical lines of communication (road, rail, externally supplied utilities, and possibly airlift) cannot be counted on to provide uninterrupted sustainment. Air bases will be attacked in the opening hours of conflict by air and should expect ground attack by small forces within days and regular units within weeks. In this environment, we should strive for base self-sufficiency, to the maximum extent possible, until changes in the threat or support posture dictate a new concept.

Project RELOOK Phase IV Report (Logistics Concept), AFLMC/CD, 6 Nov 86

### Background

Determining the best way to support US and allied forces in a European conflict logistically has been a concern of our leadership for years. Military groups and civilian think tanks have done countless studies; yet, defining the optimum logistical concept of operations for warfare continues to be a subject for debate. In April 1986, the Directorate of Logistics Plans and Programs, HQ USAF, chartered the Air Force Logistics Management Center to reexamine base-level logistical concepts of operation for supporting air warfare. The tasking, called "Project RELOOK," specified a *qualitative review of the logistical concept needed to support a high-intensity conventional conflict in Europe*.

The logistical functions outlined in RELOOK were those normally found at a typical Air Force base: supply, transportation, maintenance, logistics plans, contracting, and civil engineering and services. Figure 1 shows the RELOOK team composition, which was augmented by Air Staff representatives from logistics, engineering, and operations directorates. This article examines the basic approach, findings, and recommendations of the RELOOK team.

### A Punishing Environment

To define a workable logistics concept accurately, RELOOK first examined key elements relevant to a European wartime environment. Team members reviewed previous studies and documents relating to the European theater. The team visited Europe and discussed environmental factors with US and NATO logistics, intelligence, and operations staff members. Prior to visiting Europe, many RELOOK team members had a preconceived notion of the ideal logistical concept for the theater. It basically paralleled the view popularized by the "Air Force 2000" study; i.e., highly

### RELOOK STUDY TEAM PRIMARY MEMBERS

<b>Chairman</b>	<b>Mr Ed Jones</b> Deputy Commander, AFLMC
<b>Engineering &amp; Services</b>	<b>Col Jim Rosa</b> Director of Information Management Systems, AFESC
<b>Environment &amp; Concept</b>	<b>Lt Col Dave Rutenberg</b> Editor, <u>AFJL</u> , AFLMC
<b>Contracting</b>	<b>Lt Col Tom Jones</b> Director of Contracting, AFLMC
<b>Supply</b>	<b>Lt Col Tom Nettles</b> Director of Supply, AFLMC
<b>Transportation</b>	<b>Lt Col John Gilbert</b> Director of Transportation, AFLMC
<b>Systems &amp; Ops Research</b>	<b>Mr Ron Hare</b> Director of Logistics Analysis, AFLMC
<b>Maintenance</b>	<b>Major Terry Gaddis</b> Chief, Training Division Directorate of Maintenance, AFLMC
<b>Logistics Plans</b>	<b>SMSgt Scott Petersdorf</b> Project Manager Directorate of Logistics Plans, AFLMC

Figure 1.

flexible, maneuverable, logistics functions capable of being dispersed to support an operational concept based on similar principles. However, the team quickly recognized several indications of a shift in the combat environment of the European theater. This shift, it appeared, would make a concept based on lean operating bases, flexible resupply, and widely dispersed assets very risky. Indeed, the combat environment would be unlike anything seen before by US forces and would demand a logistics concept geared to:

- a geographically shallow theater with few rear area "sanctuaries" available for safe placement of logistical facilities and stocks;
- vulnerable and potentially oversaturated lines of communication (LOC) impacting reliable and timely flow of goods and/or information;
- assumption that air bases will be under attack from air and ground forces within the opening hours of conflict and repeatedly thereafter (based on enemy doctrinal and strategic emphasis);

actions should not be taken which degrade base self-sufficiency.

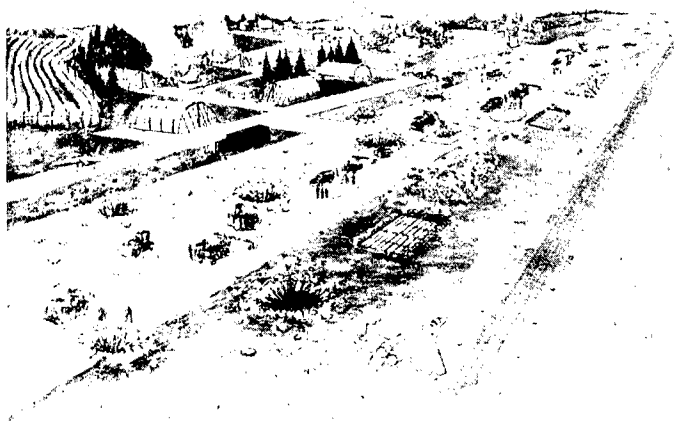

Artist's concept of a runway area after an attack from enemy aircraft. Illustrates the need for maximum base self-sufficiency.

- unpredictable damage to runways, taxiways, utilities, and facilities;
- early disruption of NATO rear area LOCs, transfer points, and command, control, and communications (C<sup>3</sup>) capabilities;
- a majority of NATO airpower capability located, and in training, outside the theater having to deploy to theater air bases prior to engaging the enemy;
- US and NATO weapon systems which, for the foreseeable future, are dependent upon a large store of consumables and repair components, as well as some industrial capability for the repair and refurbishment of aircraft, utilities, and facilities;
- a large sunk investment and funded upgrade program providing many hardened air base facilities with on-base dispersed assets and passive concealment countermeasures; and
- uncertainty in ability to predict specific resource usage, battle losses, and damage profiles to air bases or theater infrastructure.

## Defining a Logistics Concept

After visiting Europe, studying environmental factors, and further researching enemy doctrine, the team concluded successful logistics support had to be based upon US installations in Europe being self-sufficient to the maximum extent possible. This concept, termed "maximum base self-sufficiency," has two key features:

(1) It reduces the risk of installations relying on those capabilities most vulnerable during wartime (resupply of spare parts, external command, control, communications, and computer (C<sup>4</sup>), and rear area industrial capabilities).

(2) It supports the current NATO direction of strengthening and hardening US and host facilities.

In further fleshing out this concept, the team defined six attributes (Figure 2) that were critical to achieving and maintaining maximum base self-sufficiency.

**Organic maintenance capability.** From the start of hostilities until assurance of local air superiority, the fighting base must possess sufficient maintenance capability (aircraft, vehicles, utilities, pavement—all assets necessary to prosecute war), to regenerate weapon systems to meet operational taskings. Where choices exist in the allocation and positioning of support assets, base self-sufficiency should be paramount;

Organic Maintenance Capability  
Minimum External Resupply  
Internal Transportation Capability  
Assured Internal C<sup>4</sup>  
Survivable Resources  
Personnel Self-Sufficiency

Figure 2.

**Minimum needed for external resupply.** The self-sufficient base must assume that LOCs (physical and information-carrying) to regional, theater, and rear area sources will become unavailable at the start of hostilities and for intermittent periods until control of the air and rear area LOCs is obtained. Warning of conflict may be assumed, but warning of specific attack cannot. The use of off-base sources of supply is compatible with self-sufficiency if the base possesses the ability to retrieve sustaining goods from them. This attribute does not preclude or discourage the development, protection, and use of external LOCs for resupply; rather, it recognizes maximum internal capability as the most viable and survivable option given the environment.

**Organic transportation capability.** Adequate survivable transportation assets are required for moving people, supplies, and equipment to where they are needed. Lack of external supply requires that all available assets (people and equipment) be properly positioned, rapidly moved to protected areas as they become available, immediately transported for repair or refurbishment, and repositioned as operational taskings require. Organic transportation allows effective use of all assets to compensate for lack of external support. In addition, it helps assure the ability to retrieve needed off-base resources without overdependence on external communications or scarce common transportation resources.

**Assured internal C<sup>4</sup>.** All available assets and capabilities must be effectively put to use to make up for lack of external replenishment. Accordingly, information regarding needs, positioning of resources, consumption, and base operability must be instantly available to decision makers. Likewise, decisions and priorities must be rapidly transmitted to those able to react. Form is unimportant; function is critical. This attribute does not minimize the value of external information flow, but places internal C<sup>4</sup> in a mandatory category, for both controlling resources and keeping people informed about the status of their fighting unit, dependents, and other critical concerns.

**Survivable resources.** Inability to replace all resources from off-base sources makes preservation of available assets critical. People, consumables, facilities, information, and weapon system regeneration assets must be preserved to the maximum extent possible. This attribute can be dealt with using both active and passive measures.

**Personnel self-sufficiency.** Personnel available at the start of hostilities must be sufficient, in both numbers and capabilities, to carry out the mission, generate successful sorties, preserve base resources, repair attack damage, protect the base from ground attack, and relocate or destroy base critical assets under threat of being overrun. People's concerns, worries, and fears are also important elements of their ability to perform in wartime.

These attributes describe the key characteristics of a base capable of surviving and operating in the punishing environment envisioned by the team. Presence of all the attributes is necessary for the concept of base self-sufficiency to be fully realized. Lack of any critical attribute would degrade or negate the concept and require compensating in some way other than self-sufficiency. (Toughened air LOCs, for example, would help compensate for inadequate spares or maintenance capability.) These critical attributes formed the foundation for assessing current logistics operations, described later in this article.

***"A base's capability to survive and generate aircraft must be made as insensitive as possible to the effects of enemy action."***

It should be made clear that RELOOK proposed "maximum" and not "total" base self-sufficiency. Total self-sufficiency is not achievable, certainly not for any period of time. A base cannot stock all munitions, spare parts, and other commodities needed for the duration of the war. Nor can a base assure a sufficient number of personnel are assigned throughout the conflict. RELOOK in no way discourages strengthening the capacity of inter- and intra-theater LOCs to provide resupply of items and personnel. But, given the wartime environment, a base cannot *rely* on these LOCs to be operational, especially in the early stages of conflict. A base's capability to survive and generate aircraft must be made as insensitive as possible to the effects of enemy action. In short, a base must be able to fight on its own rather than risk withering at the end of tenuous, heavily damaged supply lines. It should be noted this self-sufficiency concept applies equally as well to all allied forces, not just to US contingencies.

How long, then, should we plan for a base to be self-sufficient? The length of time a base is able to operate on its own is obviously scenario and location dependent, but the team believed the self-sufficiency period should be "certainly days; probably a week; less than a month." Specific time frames are arguable, but the team believes the basic point is, given the environment, the base would be in a better position to survive and launch sorties on its own than to depend upon rear area sanctuaries and their associated LOCs that are becoming increasingly vulnerable.

The maximum self-sufficiency concept seems to advocate increasing the individual base's capabilities quantitatively—by stocking more spare parts, fuels, and munitions plus assigning more personnel at each base. While RELOOK would not disagree with these quantitative improvements, the team recognized the limitations (financial, political, and physical) of such an approach and, therefore, concentrated on achieving greater forward capability through qualitative improvements. This qualitative approach can be broadly grouped in four main areas:

- (1) Expanding the internal flexibility of the unit/base organization.
- (2) Improving the quality and completeness of information available to command authorities.
- (3) Providing an increased range of skills and training to compensate for personnel losses and allow concentration of effort where most needed.
- (4) Providing for more unit cohesion and clearer command and control during the transition from peacetime to wartime.

To translate this basic approach into specific actions, the team assessed the ability of our current logistics structure to achieve a sufficient degree of base self-sufficiency. While the RELOOK charter was to review a logistics concept for supporting *European* air operations, the team also considered how its recommendations might be applied to supporting conflicts in other theaters. In other words, the team wanted the suggestions resulting from its assessment to offer improvements to a unit's fighting capability in all contingency situations, since US units are usually tasked with responses in many theaters and environments.

The actual assessment of the concept consisted of a multi-disciplinary look at the Air Force's current capability to satisfy each of the six critical attributes of maximum base self-sufficiency. Each deficiency was analyzed and recommendations offered to resolve (or minimize the impact of) the shortfall.

## What Should Be Done?

*Organization:* After extensive review, the team concluded the current overall base organizational structure was not "broken." However, realignment of selected functions could significantly improve peacetime planning and execution of wartime tasks. Specifically, the team recommended steps be taken to:

(1) **Create a centralized wing-level planning function.** This would pull together the currently fragmented logistical and operational planning function into a single focal point for integrated planning in support of the wing mission.

(2) **Establish a centralized base operability function.** This would strengthen unity of command and control and improve peacetime operability training. The Air Force is already moving in this direction, having established these functions at selected bases.

(3) **Redesign selected aircraft maintenance units (AMUs) as individual aircraft generation squadrons.** This would better align production responsibilities with common authority. Currently, many of these larger AMUs have several hundred personnel assigned. Span of control, personnel, and administrative problems impact the effectiveness of the AMU leadership and detract from unity of command.

*Base Operability Training and Evaluation:* Considering the Soviet doctrine of surprise, allied forces are likely to be under attack long before reinforcements could be provided. As a result, in-place troops must be capable of being used in a number of ways. Personnel must be trained to perform a variety of tasks not only in their primary functional area but also in survivability and base recovery tasks. RELOOK offered four recommendations in this area:

(1) **Increase basic individual contingency skill training for all military personnel,** to include such functions as buddy care, weapons familiarization, and chemical warfare protection. SALTY DEMO and other exercises demonstrated the widespread lack of proficiency in these primary wartime skills. They are basic not only to individual survival, but to the ability of the base to recover effectively and regain operational capability.

(2) **Establish secondary skills for all personnel,** including basic base recoverability tasks and utilization of technical skills into related areas. Debris removal, firefighting, base defense, and medical augmentation will demand additional manpower during base recovery. Also, possible shortages of skilled personnel in critical areas dictate the need for

individuals to receive familiarization training on tasks related to their primary skills, such as a vehicle mechanic being trained on the basics of aerospace ground equipment (AGE).

(3) **Increase the degree of realism during exercises and training.** Aircrews receive training as realistic as possible, yet exercise training for ground support personnel is limited and often is either not planned in the scenario or is "simulated away" during the actual exercise. Similarly, shortages of spare parts and support equipment are not treated as real and the aircraft not grounded for a period of time as could be expected in wartime.

(4) **Consolidate base performance expertise into a single CONUS base** where operability techniques can be perfected, exercised, and exported to other bases. The Air Force learned a great deal from exercises like SALT DEMO, yet developing those lessons into institutionalized processes remains a substantial challenge. A single focal point needs to be established to develop and refine these procedures and to train others throughout the Air Force.

*Command and Control and Unit Cohesion:* The environment of a European conflict dictates a unit must be able to perform at maximum effectiveness as quickly as possible. Command and control initiatives and efforts to improve unit cohesiveness are key elements toward achieving this increased effectiveness. To help reach these objectives, RELOOK recommended planners attempt to:

(1) **Have as many people as possible deploy from one CONUS unit,** thereby minimizing command and control disruption and maintaining maximum unit cohesiveness. This would preclude commanders and supervisors from having to spend critical time organizing their functions and attempting to assess the skills and expertise of personnel new to them.

(2) **Establish only one of a specific functional unit at each deploy location.** For example supply personnel could arrive at the deployed site from a number of different CONUS bases. To improve personnel utilization and strengthen command and control, these personnel need to be functionally aligned under a single commander (a deployed chief of supply).

*Integration, Assurance, and Prioritization of Information Flow:* A primary concern of the RELOOK team and of others the team interviewed was the lack of integrated information flow and the potential impact on wartime operations.

RELOOK's environmental assessment indicated significant possibility for major disruptions in communications due to both oversaturation and enemy action. To improve integration of these vital linkages, RELOOK suggested actions be taken to:

(1) **Improve logistics processes and create automatic information interfaces,** thereby decreasing vulnerabilities created by delays and the need for redundant data. Logistics processes have yet to establish effective information interfaces; data "seams" are evident between the various functional elements. While this is a known problem in peacetime, wartime activity will further stress the ability of logistics functions to share information.

(2) **Push for an assured and survivable C<sup>4</sup> capability.** Being able to communicate effectively during wartime is absolutely basic, yet exercises and studies have shown this capability cannot be guaranteed.

(3) **Ensure policymakers review existing requisitioning and transportation priority procedures** in light of the anticipated oversaturation of both the supply and transportation systems in wartime. In essence, it is likely that virtually every logistics request will be deemed a priority and it will be difficult (if not impossible) to identify the "true" priorities. The wholesale logistics communities, in conjunction with overseas commands, need to review requisitioning and transportation policies and procedures.

## Summary

The RELOOK team recognized there is no single logistics concept suitable for the multitude of scenarios possible in the European theater. Accordingly, the team supports continued emphasis on built-in flexibility measures such as reducing LOC vulnerabilities and increasing overall intra-theater and rear area logistics capabilities. However, based upon the current environment as seen by the team, the concept of maximum base self-sufficiency is the best hope through the remainder of this century for reducing reliance on external assistance which may not be continually available during wartime. The qualitative improvements recommended by RELOOK are vital to helping ensure bases are not prevented from having the capability to fight and win. **ATF**

### *Most Significant Article Award*

The Editorial Advisory Board has selected "Combat Support Doctrine: Coming Down to Earth" by Lt Colonel William T. McDaniel, Jr., USAF, as the most significant article in the Spring issue of the *Air Force Journal of Logistics*.

### *Most Significant Article Award*

The Editorial Advisory Board has selected "Combat Sustainability and Reconstitution Warfare: The Missing Link in Air Force Basic Doctrine" by Colonel Orville M. Collins, USAF, as the most significant article in the Summer issue of the *Air Force Journal of Logistics*.

## Unprepared for War: Aviation Logistics and The Home Front, 1917-1918

Robert P. Smith  
Office of Air Force History  
Bolling AFB DC 20332-6098

When America entered the war on 6 April 1917, aviation was in a critical state. The organization charged with the air arm's development lacked the funds, materiel, personnel, and experience in designing, producing, and using modern combat aircraft. Of the 147 airplanes delivered to the Signal Corps before 1917, most had been lost in operations or declared obsolete and destroyed. No American-made plane approached the combat standards of the European Allies; no American aeronautical specialist divined the war's aviation requirements. Ten years of official neglect precluded a working knowledge of the engine, airframe, and armament components required at the front.

**"The United States had no manufacturing facilities capable of large-scale aircraft production."**

Of even more importance, the United States had no manufacturing facilities capable of large-scale aircraft production. Less than a dozen firms worked in aviation and, with the exception of the Curtiss Airplane Company, there were none who were equipped to manufacture on a quantity scale. When the war was declared, the total capital invested in US aircraft development barely reached \$10 million; actual working assets amounted to less, "as many of the companies were badly off financially, having spent great amounts of their capital in experimental work."<sup>1</sup> Whatever the state of private enterprise, the Aviation Section's situation was primitive, for "the Army itself had paid very little attention to its Air Service—and had not tried to keep itself informed of the possibilities and impossibilities of aircraft."<sup>2</sup>

Faced with this unpreparedness and reluctant to grasp the gravity of the situation, Washington's aviation planners groped their way toward a viable production program without any serious consideration of the dismal state of American industry and aeronautical technology. Benedict Crowell, a leading architect of industrial mobilization, concluded that "... there was no phase of the immense undertaking in which the United States was so utterly unprepared."<sup>3</sup> It was all the more remarkable, then, that the United States produced several thousand aircraft and perhaps the finest aeronautical engine of its day. Winston Churchill once remarked that in the field of military procurement, production followed a set pattern: "The first year, nothing; the second year, a trickle; the third year, all you want."<sup>4</sup> America's World War I aircraft program compressed this pattern into eighteen months.

War increased expectations, and nothing captured the imagination more dramatically than the idea of an armada of American-built airplanes flying over the German lines.

Appearing before Congress in May 1917, Brigadier General George O. Squier, the newly named Chief Signal Officer, eloquently spoke of putting "the Yankee punch into the war by building an army in the air, regiments and brigades of winged cavalry mounted in gas-driven flying horses."<sup>5</sup> Squier's optimism aside, aircraft production planners faced monumental problems on the eve of America's entry into the war.

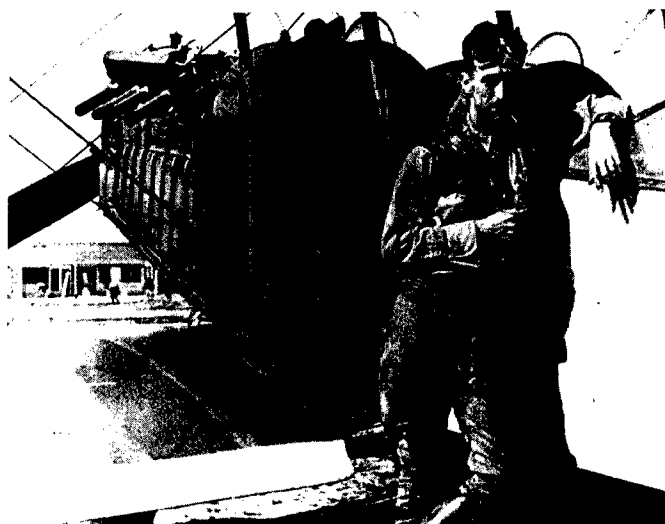

A pilot-trainee in the United States during World War I.

Secretary of War Newton Baker admitted before Congress that "there was perfect confusion" in Washington; "everybody was bringing suggestions."<sup>6</sup> Crowell agreed, adding that "all the paraphernalia that complete the efficiency of combat airplanes were entirely unknown to us."<sup>7</sup> Precedents were nonexistent, and "the methods of supply found adequate in time of peace proved woefully ineffective (in time of war), equipment lagging far behind personnel."<sup>8</sup> Washington was a madhouse and no more so than in aviation production matters. The administration and Congress created a whole new bureaucracy to cope with this massive undertaking, many of whose elements sprouted from several prewar committees.

Organized on 3 March 1915, the National Advisory Committee for Aeronautics supervised and conducted research in aviation. During the war, it cleared inventions submitted to the Army and Navy and it constituted a general source of information for the aircraft industry. Founded two years later, the Joint Army and Navy Technical Aircraft Board assumed responsibility for the basic aircraft program. Composed of naval and military experts, the Board standardized designs and general specifications for aircraft. The Board's purely advisory recommendations, however, were often ignored by civilians in charge of production.<sup>9</sup>

A third committee, the Aircraft Production Board, which was established just after the war began, was charged with "coordinating the designs for Army and Navy aircraft and engines in addition to cooperating with the military services to remedy difficulties in production."<sup>10</sup> Headed by Detroit businessman, Howard E. Coffin, the Aircraft Board exercised more direct control over aircraft production and procurement than either of the two previous agencies. But with no authority to commit the government to a particular manufacturer or design, the Board could only help formulate programs, investigate manufacturing concerns, and recommend companies to the Army for engine and airframe production contracts. However, although strictly advisory in nature, most of its suggestions were approved.<sup>11</sup>

Henry H. "Hap" Arnold remembered some thirty-odd years later that the Aircraft Production Board "was not an organization that was to inspire confidence among the men who had to fly the planes." Calling Coffin and his associates "Armchair Colonels," Arnold faulted them for deciding aircraft and supply policies without consulting airmen.<sup>12</sup> Regular Army officers played only minor roles in formulating production, procurement, funding, materiel, and personnel policies.<sup>13</sup> Inexperienced in large production programs, the Signal Corps delegated management control to the Board. Since contracts for, and purchase of, airplanes and equipment remained within regular Corps procurement channels, duplication and confusion were the results. To regularize the Aircraft Production Board's position, Congress recommissioned it the Aircraft Board, an action which did little to unify program control.

**"Ribot's program envisioned 22,000 airplanes and 43,800 engines in one year."**

The basic structure used by the Corps was established on 24 July 1917, when Congress authorized Wilson to "provide through the War Department for the purchase, manufacture, maintenance, and operation of all types of aircraft, with the necessary equipment." The War Secretary vested this authority in the Chief Signal Officer, General Squier, who organized an Equipment Division on 2 August 1917, to generate and acquire airplanes, engines, and accessories. Headed by Edward A. Deeds, an "Aircraft Colonel" and Aircraft Board member, the new division incorporated the Aircraft Engineering and Inspection Divisions.<sup>14</sup>

Lacking a specific production program, and beset by suggestions both from within the government and from Allied missions sent to the United States to seek materiel assistance, the Signal Corps turned to the Aircraft Production Board, which foundered without adequate information for almost a month. Then, on 24 May, French Premier Alexandre Ribot cabled Wilson, knowingly giving shape to America's aviation plans:

It is desired that in order to cooperate with the French aeronautics the American government should adopt the following program: the information of a flying corps of 4,500 airplanes, personnel and materiel included, to be sent to the French front during the campaign of 1918. Total number of pilots, including reserves, should be 5,000 to 50,000 mechanics. Two thousand planes should be constructed each month, as well as 4,000 engines by the American factories. That is to say, in the first six months of 1918, 16,500 planes of the latest type and 30,000 engines will have to be built. The French Government is anxious to

know if the American Government accepts this proposition, which would allow the Allies to win the supremacy of the air.<sup>15</sup>

Referred to the Joint Army and Navy Technical Aircraft Board for evaluation, Ribot's program envisioned 22,000 airplanes and 43,800 engines in one year.<sup>16</sup>

These numbers must have staggered the American imagination when compared with other estimates. The National Advisory Committee on Aeronautics, for example, recommended producing 3,000 planes in 1918, 6,000 a year later, and 10,000 in 1920.<sup>17</sup>

Ordered to draft a detailed program based on Ribot's cable, Major Benjamin D. Foulois suggested a \$707 million appropriation; cuts reduced it to \$640 million. Foulois reported to a 1919 Congressional committee on aviation that his one thought "was the supreme opportunity and the supreme haste."<sup>18</sup> Secretary Baker endorsed the plan on 27 June, testifying proudly that "it lives up to America's tradition of doing things on a grand scale. The War Department is behind this program with every ounce of enthusiasm at its command."<sup>19</sup> The proposal passed both houses of Congress on 21 July and President Wilson signed it into law three days later. "When one contrasts this unprecedented liberality on the part of Congress with its previous parsimony," wrote Clayton Bissell in *A Brief History of the Air Corps*, "there is little wonder that popular imagination ran away with reality and visualized, as accomplished, a feat beyond the power of human endeavor."<sup>20</sup>

When the cable arrived, Arnold, who was just another young colonel working on production and procurement in the Office of the Chief of the Signal Corps, wrote years later that "the main headache in trying to create an American Air Service was due almost entirely to shortages, in many cases complete absence of materials, especially airplanes." The Washington establishment's ready acceptance of Foulois' grandiose design precluded such a deficit.<sup>21</sup>

The so-called \$640 Million Dollar Program called for building 24 flying fields within the continental United States, a monumental undertaking considering there were only eight operational fields in 1917. Overburdened with its own requirements for supplying the future American Expeditionary Forces, the Quartermaster Department ceded its construction responsibilities to the Aviation Section's recently formed Supply Group. Invested with new authority, the group secured equipment and materials from the Quartermasters themselves, from open-market purchases, and from other available sources. When the last field opened on 1 August 1917, sufficient equipment was on-hand to handle arriving personnel.<sup>22</sup>

Planned for pilot instruction, not one of the fields offered training courses for mechanics—a gross miscalculation considering that "one training aircraft was worn out in training each flying cadet."<sup>23</sup> The need for mechanics reached such proportions that the Air Service launched a propaganda blitz in December 1917 to induce young Americans to enlist as aviation mechanics. The Service estimated that it would need 100,000 men, half of that number to be recruited immediately. Similar numbers were required for service overseas with the Air Service, American Expeditionary Forces (AEF). In addition, desperate for men to work in their aircraft factories, the French appealed for 12,000 American mechanics in the spring of 1918.<sup>24</sup>

Despite this paucity of trained technicians, the flying fields still required maintenance shops to keep the aircraft and

engines functioning. A typical maintenance unit, the Engineering Department, Ellington Field, Houston, Texas, comprised a Motor Overhaul Section, including a machine shop, an Aero Erection and Repair Group, a Final Test Area, and general work unit doing such things as gassing, cleaning, and checking engines. These units performed a valuable service in the heady, early days of the war, keeping the training planes flying until a more flexible system of repair depots was established. Since they lacked spare parts, aircraft mechanics improvised with ingenuity and makeshift tools. And with safety as their chief goal, they conducted, along with the airmen, detailed airplane inspections.<sup>25</sup>

***“Colonel Squier, Aviation’s officer-in-charge, warned Congress months before America entered the war of the great need for ‘nuts and bolt’ men, the grease monkey, the aircraft mechanic.”***

Colonel Squier, Aviation’s officer-in-charge, warned Congress months before America entered the war of the great need for “ ‘nuts and bolt’ men, the grease monkey, the aircraft mechanic. It would surprise you to learn how highly organized and complicated the Air Service is.” Continuing, Squier told the lawmakers:

It is the acme of professional and mechanical skill. . . . It requires five skilled men for each plane. When a machine comes down in war, the men go right at it, like the attendants at a horse race; they go at every single part of it instantly; they examine every part of it to see that it is right before it flies again.<sup>26</sup>

Besides mechanics, the service required organizations capable of supplying needed equipment and of performing major overhauls. To meet the emergency, the Signal Corps established four general aviation depots at San Antonio, Texas; Rockwell Field, California; Middletown, Pennsylvania; and in January 1918, Fairfield, Ohio. It created five smaller supply depots at Belleville, Illinois; Little Rock, Arkansas; Los Angeles, California; Richmond, Virginia; and Garden City, New York. Three maintenance and repair depots were also set up at Dallas, Texas; Montgomery, Alabama; and Indianapolis, Indiana, so that:

By the time the Armistice was signed, practically all wrecked airplanes that had accumulated at flying fields had either been salvaged or repaired or rebuilt, and the repair depots had been able to repair both airplanes and engines that had reached their flying limit in hours.<sup>27</sup>

While the country girded itself for battle and planners debated the size of the coming effort, the Wilson administration dispatched several fact-finding missions abroad to study Allied requirements firsthand. The most important delegation for aviation logistics, the Bolling Mission, sailed for Europe on 17 June 1917. Led by Major Raynal Bolling, and composed of 104 aircraft specialists, including 2 each from the Army and Navy, 7 civilian scientists and engineers, and 93 production workers, the commission visited major aircraft manufacturers in England, France, and Italy. Bolling held high-level discussions with Allied aviation experts. Its final report, issued on 4 September 1917, profoundly affected the final outline of the American aviation materiel effort.<sup>28</sup>

The mission’s early investigations, however, convinced its members that no matter how optimistic were the promises and

projections of production emanating from the United States, “nothing in the way of finished and satisfactory aviation material could be expected to arrive in Europe from the United States before about July 1918.” This meant that the Air Service, AEF, in order to participate in the spring campaign of 1918 had to obtain its necessary equipment elsewhere.<sup>29</sup> Since the Allies possessed trained and experienced air forces, the Bolling Mission recommended that until such time as the United States could produce aircraft in sufficient numbers to support an air force overseas, it procure its airplanes from European manufacturers. In return, the United States would supply its Allies with raw materials and, when available, mechanics. In the strongest possible terms, the report also called for the immediate production of American-built aircraft.<sup>30</sup>

The decision to promote quantity production of standardized airplane types whenever possible led to the design and manufacture of the Liberty Engine, the outstanding contribution of the United States to aeronautical development during the war.<sup>31</sup> Its success created countless problems for the overall aviation production effort. Concentrating all its energies on producing Liberty engines, the Aircraft Production Board neglected the development of other motors and instead chose to adapt airplanes to meet Liberty specifications. This decision proved impossible and caused unnecessary aircraft factory delays.

***“Standardization simplified tooling, the training of labor, manufacturing, field maintenance, and spare parts distribution.”***

As the essence of mass production, standardization simplified tooling, the training of labor, manufacturing, field maintenance, and spare parts distribution. Because designers planned airframes around engines, it proved unproductive to force all designs to conform to one engine’s features regardless of the aircraft’s function or characteristics. The attempt to fit the Liberty to European planes prevented production of a variety of planes in any quantity. In some cases, European airframes could not handle the Liberty’s increased power and weight. Writing in his memoirs ten years after the war’s end, Brigadier General William “Billy” Mitchell called the decision to install a Liberty in an English DeHavilland (DH-4) a “disastrous mistake,” since the DH-4 was made for an English and not an American-made motor. This action, Mitchell argued, delayed delivery of American equipment to America’s air forces for one year, “and constituted one of the

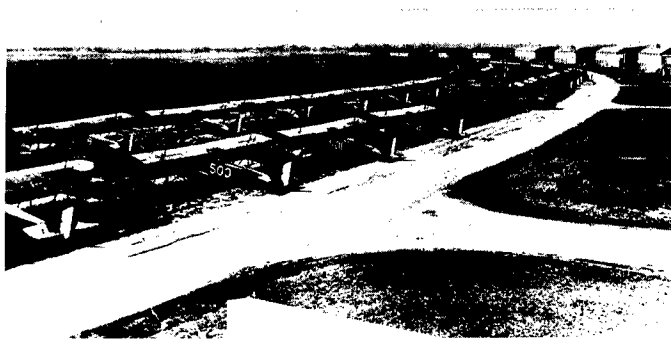

Brooks Field, Texas, one of the 27 flying fields the USA used to train pilots in WWI. The airplanes are American-built DH-4s, DeHavilland.

most serious blunders that has ever occurred in our military."<sup>32</sup>

Standardization also required revisions in designs and specifications, and each change in the program meant that new contracts had to be let or existing ones modified in response to the new situation. These weekly schedule alterations led to factory chaos, labor unrest, materiel shortages, and unfulfilled production schedules.<sup>33</sup>

Contracts awarded according to no clearly-defined principle were another cause of concern to production planners. The Signal Corps granted contracts to firms able to produce needed materials. However, sometimes companies received orders they did not want; at other times competent manufacturers were denied government subsidies. Businesses were selected almost at random. As a consequence, contracts themselves underwent radical changes commensurate with wartime conditions. Of the three most common methods—competitive, cost-plus, and fixed price contracts—cost-plus became the favored form of aircraft procurement. In addition to reimbursing the supplier for all labor, materials, plant depreciation, and overhead expenses, the government guaranteed a fixed profit on aggregate costs and a premium for any reduction of actual expenditures below the provisional price per unit.<sup>34</sup>

***"An aviation history revealed 'there were no radio supplies; there were no gunnery supplies, so that it was impossible to start any kind of advanced training.'"***

Between 1 September 1917 and 1 February 1918, the results of the hasty, ill-advised, and erroneous decisions made in the early days of the war became painfully obvious. Unfortunately, the Wilson administration masked these failures in a chorus of public pronouncements glorifying the aircraft production program. On 21 February 1918, for example, an official release reported:

The first American-built battle planes are today en route to the front in France. This shipment, though in itself not large, marks the final overcoming of many difficulties met in building up this new intricate industry.<sup>35</sup>

The press notice failed to mention that the shipment consisted of one DH-4—the next delivery did not occur for several weeks. The statement was an official admission that it had taken almost a year to produce a handful of airplanes.

This failure in aircraft production, which Major General William L. Kenly, the Director of the Division of Military Aeronautics, called "... more serious than anticipated," greatly affected the training programs then underway at America's various airfields.<sup>36</sup> Not only did the schools lack adequate numbers of planes with which to train cadets, but there was also a paucity of spare parts for the maintenance and repair of the aircraft they did possess. An aviation history found in Arnold's papers revealed "there were no radio supplies; there were no gunnery supplies, so that it was impossible to start any kind of advanced training." Matters came to a climax in December when two-thirds of all Air Division training machines were "laid up due to a lack of spares and no spares forthcoming." The Signal Corps Production Division readjusted its priorities to include a

greater emphasis on spares parts. In the end, however, "the entire air Service structure . . . failed due to over-confidence on the part of the Production Division and the inability of the Air Division to properly estimate what the actual supply would be."<sup>37</sup>

The inability of the Aviation and Production (nee Equipment) Divisions to cooperate on matters of extreme urgency contributed to this dilemma. Often the latter ignored the aviators when important decisions had to be made. This problem became especially acute in October when Foulois left Washington for France. By December, the question of supply and spare parts for engines and airplanes reached such dimensions that a special Expediting Section for all supplies was created in the Signal Corps' Supply Division. The failure of the Equipment Division to promptly order various small items such as camshafts, valve springs, and assorted other parts, sometimes as much as a month after the Air Division's purchase request had been submitted, made this decision imperative. Under the new system, when the Air Division received a supply request from one of its flying fields, it submitted that requisition to its Supply Group, which in turn submitted it to the Equipment Division. The Expediting Division then followed up by tracing the order to its final placement. Conditions remained essentially unchanged, however, through the spring of 1918.<sup>38</sup>

Calculating to counteract this divisiveness and to still political rumblings over the failure of America's aircraft production program, Woodrow Wilson removed aviation from the Signal Corps on 21 May 1918 and placed it under the newly created (War Department) Bureau of Aircraft Production (formerly the Equipment Division) and the Division of Military Aeronautics (once the Aviation Division). The division was responsible for personnel, supply, training, and setting performance standards for materiel, under the direction of General Kenly. John D. Ryan, successful businessman and former chairman of the Aircraft Board, managed the Bureau and the quantity production of aircraft suitable for the Division. Both men reported directly to the Chief of Staff of the Army, General Peyton March.<sup>39</sup> A major improvement over the old system, the two departments managed to stabilize the aviation agenda sufficiently for quantity production to begin.

Old difficulties persisted, however, and the new organization faced three immediate crises: (1) a multiplicity of programs received from abroad for supplying air service personnel; (2) no comprehension of the proper methods for testing and providing equipment used by the aviators; and (3) an imperfect arrangement whereby one group produced equipment for use by an entirely different section—the two having no common leader.<sup>40</sup> Internal frictions remained, dooming the aviation program to continued inefficiency and lethargy.

The President realized the absurdity of two interdependent agencies directed by two co-equal administrators and, on 27 August 1918, appointed Ryan Director of the Air Service and Second Assistant Secretary of War.<sup>41</sup> Coming less than three months before the 11 November Armistice, however, this reorganization played a minor role in the war's final outcome.

The difficulties that plagued aviation production in the States were not confined to organizational imbalances. Raw materials, for example, were always in tight supply, although shortages never reached series levels. Blueprints were frequently of such poor quality that they had to be redrawn. Foreign measurements and specifications arrived at American

plants in metric equivalents, thus causing further delays. The government mistreated some manufacturers and procrastinated in awarding firm production orders, forcing contractors to ignore materiel and labor requirements. In some cases, the government modified or cancelled given orders. Technically, frequent design specification changes made efficient mass production impossible. Finally, when finished aircraft and engines reached the delivery stage, there were no rail or water transports available to carry them to their destination.<sup>42</sup> By late summer 1918 this irksome tangle seemed to be unravelling but not before heavy damages had been inflicted on the American war effort at home and abroad.

It took more than a year to get production started in the United States after war was declared, and fifteen months to begin quantity production. When the war ended, the aircraft production and procurement program had improved considerably. The creation of the Division of Military Aeronautics and the Bureau of Aircraft Production in June 1918 brought more expert and rational control to the aviation program, encouraging American designers to craft machines specifically for the Liberty engine.

**"The DeHavillands and Liberties were made despite program conditions and demonstrated the inventiveness of the aircraft industry to overcome the bureaucratic bungling of the so-called experts in Washington."**

The aircraft production effort's dismal showing in late 1917 and early 1918 derived from the unfamiliarity and ineptness of the prewar production planners. The DeHavillands and Liberties that emanated from American factories were made despite program conditions and demonstrated the inventiveness of the aircraft industry to overcome the bureaucratic bungling of the so-called experts in Washington.

Nowhere were these deficiencies felt more acutely than at the front, where the Air Service, American Expeditionary Forces tried to cope with a moribund stateside aviation program, a 3,000 mile supply line, and a European production program of uncertain dimensions. The war's demands, especially the new technology, overwhelmed the War Department's supply bureaus accustomed as they were to peacetime procedures. For Army aviation, World War I exposed an organization heavy in patriotic ardor but short of the actual men and machines needed to douse the flames of war.

#### Notes

<sup>1</sup>Signal Corps, Equipment Division, Plane Production Division, 5 January 1918, pp. 1,2, RG111, Entry 8, NA. The most thorough evaluation of the Air Service, AEF is *Gorrell's History of the American Expeditionary Forces Air Service, 1917-1919*, located on microfilm(10-35-2) in the National Archives. Consisting of 58 rolls, the collection represents a comprehensive history of the Air Service. Of particular interest to this chapter was Series I, Vols. 1 thru 32. Much of the information found in Gorrell was located elsewhere, in printed format.

<sup>2</sup>"History of Aviation Section, Signal Corps and Division of Military Aeronautics, April 1917 to 1 October 1918," Arnold Papers, no author, no date, Box 222, LCM, 4 (hereinafter referred to as *History, Aviation Section*).

<sup>3</sup>Crowell, Benedict. *America's Munitions, 1917-1918* (Washington, 1919), p. 26.

<sup>4</sup>O'Connell, Jr., Charles F. "The Failure of the American Aeronautical Production and Procurement Effort During the First World War," Master of Arts Thesis, Ohio State University, 1978, Air Force Logistics Command Historical Archives, p. 96.

<sup>5</sup>"Fiftieth Anniversary: A Pictorial Review of Air Force Materials Laboratory, Wright-Patterson Air Force Base," ND, Air Force Logistics Command Historical Archives, p. 2.

<sup>6</sup>U.S. Congress, House of Representatives, War Expenditures: Hearings before Subcommittee No. 1 (Aviation) of the Select Committee on Expenditures in the War Department, Sixty-Sixth Congress, First Session, Vol. I, 8 (hereinafter referred to as *War Expenditures: Hearings*).

<sup>7</sup>Crowell, Benedict and Robert F. Wilson. *The Armies of Industry: How America Went to War* (New Haven, 1921), p. 326. Crowell was appointed Assistant Secretary of War in 1918.

<sup>8</sup>Bissell, Clayton L. "Brief History of the Air Corps and Its Late Development," Air Corps Tactical School, Langley Field, Virginia, 1927, pp. 28, 42.

<sup>9</sup>Holley, I. B. *Ideas and Weapons. Exploitation of the Aerial Weapon by the United States During World War I* (New Haven, 1953), p. 66.

<sup>10</sup>*Ibid.*, p. 67. Robert C. Hilldale, First Lt, Air Service (P), "History of the Development of Aircraft Production During the War of 1917," Part V, Organization, Chapter IV, RG18, Series 107, Box 1, NA, pp. 52, 53.

<sup>11</sup>Dockey, Philip S. "The Liberty Engine, 1918-1942," *Smithsonian Annals of Flight*, Vol. 1, No. 3, pp. 55-56. See also Hilldale, *Aircraft Production*, p. 576. Coffin was vice president of the Hudson Motor Car Company.

<sup>12</sup>Arnold, Henry H. *Global Mission* (New York, 1949), pp. 57, 117.

<sup>13</sup>Memo, Col Gillmore to Executive, Office of the Chief of the Air Service, 28 October 1919, RG18, NA.

<sup>14</sup>Frey, Royal. *Evolution of Maintenance Engineering—1907-1920*, Air Force Logistics Command Study No. 327, AFCHO Microfilm Collection, K201-327. Frey was the historian at the Air Materiel Command, Wright-Patterson Air Force Base, in the 1950s and 1960s. Deeds, an officer of the National Cash Register Company and a Dayton, Ohio, notable, was the central focus of the Hughes Committee's investigation. Hughes recommended courts-martial; Baker, an old friend of Deeds, demurred and shelved the report.

<sup>15</sup>U.S. Congress, House of Representatives, War Expenditures: Hearings before Subcommittee No. 1 (Aviation) of the Select Committee on Expenditures in the War Department, Sixty-Sixth Congress, First Session, Vol. I, p. 358 (hereinafter referred to as *War Expenditures: Hearings*).

<sup>16</sup>Goldberg, Alfred ed. *History of United States Air Force*, Air Training Command Pamphlet 190-1, Randolph Air Force Base, Texas, 1 June 1961, p. 2-2.

<sup>17</sup>*Ibid.*

<sup>18</sup>Testimony of Major Benjamin D. Foulois before the Aviation Subcommittee of the Select Committee on Expenditures in the War Department, 6 August 1919, War Expenditures: Hearings, I, 359-363. Exact figures for World War I appropriations were \$707,541,000 proposed by Foulois, and \$639,241,252 actually expended by the Air Service during the war.

<sup>19</sup>Mason, Jr., Herbert Molloy. *The United States Air Force: A Turbulent History* (New York, 1976), pp. 45-47.

<sup>20</sup>Bissell, *Air Service*, p. 22.

<sup>21</sup>*Aviation Section History*, p. 27. See also Arnold, *Global Mission*, p. 54.

<sup>22</sup>*Ibid.*

<sup>23</sup>Frey, *Evolution*, p. 83.

<sup>24</sup>Memo, Brig Gen C. McK. Saltzman, Signal Corps, to Chief of Staff, U.S. Army, 14 November 1917, RG18, NA, which called for 12,000 mechanics for France by the spring of 1918.

<sup>25</sup>Frey, *Evolution*, pp. 98, 101.

<sup>26</sup>*Ibid.*, p. 81.

<sup>27</sup>*Ibid.*, p. 108.

<sup>28</sup>Goldberg, *History Air Force*, p. 2-5. Bolling, a Harvard graduate and prominent lawyer before the war, organized the First Reserve Aero Squadron. Besides his mission to Europe, Bolling was variously in charge of the Air Service, Zones of Interior and Communications; Assistant Chief of the Air Service, Paris; head of the Interallied Aircraft Board; and chairman of the Joint Army and Navy Aircraft Committee. He died while on active duty.

<sup>29</sup>Sweetser, Arthur. *The American Air Service: A Record of Its Problems, Its Difficulties, Its Failures and Its Achievements* (New York, 1919), pp. 237, 238. For the final report, see Army and Navy Technical Members of the Aeronautical Commission Sent to Europe to the Secretary of War and the Secretary of the Navy, via the Chief Signal Officer and the Chief of Staff, sub: Recommendations Bearing on the General Aeronautical Policy of the United States, 4 September 1917, Foulois Papers, Box 39, LCM. See also Final Report of the Assistant Chief of the Air Service to the Chief of the Air Service, AEF, including Memo from Major R.C. Bolling, to the Chief Signal Officer, U.S. Army, sub: Report of the Aeronautical Commission, 15 August 1917, Halsey Dunwoody Papers, AFCHO. See also Memo for General Squier, Chief Signal Officer, and Mr. Howard Coffin, July 10, 1917, from Bolling, RG 18, Series 107, Box 1, Part IV: Advisory NS Co-operative Agencies, NA.

<sup>30</sup>Coffin to Bolling, 13 June 1917. See also *History, Aviation Section*, p. 83.

<sup>31</sup>Goldberg, *Air Force History*, p. 2-6.

<sup>32</sup>Mitchell, William, *Memories of World War I* (New York, 1929), p. 17.

<sup>33</sup>Frey, *Evolution*, p. 119. See also Charles Evans Hughes, "Report on Aircraft Production Inquiry," *Congressional Record*, Vol. 57, 3 January 1919, hereinafter referred to as the *Hughes Report*, p. 897. See also *History Aviation Section*, p. 34.

<sup>34</sup>*Hughes Report*, p. 900. See also Crowell, *War Contracts*, pp. 232-237.

<sup>35</sup>*Hughes Report*, p. 903.

<sup>36</sup>*History Aviation Section*, p. 41. See also "Division of Military Aeronautics, Accomplishments and Program Requirements under Major General William L. Kenly, April to November 1918," two binders, RG18, Series 111, NA, 1. An 1889 graduate of the Military Academy, Kenly attended the Aviation School at San Diego, 1916-17; was Chief of the Air Service, AEF from 24 August to 27 November 1917; was commanding officer of the 7th Field Artillery; and later served as the first president of the Army Air Service Association.

<sup>37</sup>*History Aviation Section*, pp. 41, 56.

<sup>38</sup>*Ibid.*, pp. 43, 73-75. See also Memo, D.C.E., Executive Section, War Department, Office of the Chief Signal Officer, Air Division, 26 January 1918, RG18, NA.

<sup>39</sup>*Hughes Report*, 886; Holley, *Ideas and Weapons*, pp. 68-69. See also Dayton, Ohio Research Section, United States Air Force Museum, MSS, "A History of the Bureau of Aircraft Production, 1870-1947," Vol. I, xiv, hereinafter referred to as MSS "History BAP." See also Office memo, No. 1, 21 May 1918, Division of Military Aeronautics, Col. H. H. Arnold, Assistant Director of Military Aeronautics, Foulois Papers, Box 28, File: Division of Military Aeronautics, LCM. Ryan was chairman of Anaconda Copper Mining Company and a Director of the National City Bank of New York.

<sup>40</sup>*History Aviation Section*, p. 98.

<sup>41</sup>*Ibid.*, pp. 5, 113.

<sup>42</sup>Crowell, J. Franklin. *Government War Contracts* (New York, 1920), pp. 246-250.

# Assessing Strategic Airlift Aircraft in WSMIS

Carol Schweiger  
Staff Scientist  
Dynamics Research Corporation  
Andover, MA 01810

## Background

The sustainability assessment module (SAM), a part of the weapon system management information system (WSMIS), is an integral part of the Air Force Logistics Command (AFLC) command, control, and communications initiatives. It is used in peacetime by logistics managers to assess their weapon system's projected wartime sustainability performance and to identify logistics resources and processes that need improvement to meet required performance levels. SAM is also used by operational commanders in peacetime to assess the forecasted performance of individual units based on the status of each unit's war reserve materiel (WRM) and other materiel resources needed to generate sorties or missions.

The early development and implementation of SAM focused on tactical aircraft, using Dyna-METRIC Version 3.04 as the assessment model. Tactical aircraft missions could be described in terms of sorties and their performance measured in predicted sorties generated and predicted number of not mission capable supply (NMCS) aircraft. The data necessary to feed Dyna-METRIC into SAM was collected from existing Air Force data systems and operational planning documents.

SAM was then expanded to assess additional weapon systems whose missions could be described in the same terms as tactical aircraft: tactical airlift<sup>1</sup> aircraft and helicopters. It was further recognized that the same capability assessment approach was needed to determine the sustainability of strategic airlift aircraft whose mission, in part, is to support the deployment of weapon systems already assessed in SAM. However, the concept of operations for strategic airlift aircraft could not be described in the same terms as tactical aircraft missions; strategic airlift aircraft do not fly sorties and their performance is not measured in sorties achieved. Much of the data available to describe strategic airlift missions was unique to MAC and not available through existing AFLC data sources. And, Dyna-METRIC was not structured to handle strategic airlift's unique characteristics.

Thus, a government and contractor working group embarked on a two and one-half year effort to incorporate strategic airlift aircraft into WSMIS/SAM. This effort involved two stages: a demonstration of strategic airlift assessment capability modeling and the development and implementation of a SAM production capability for strategic airlift.

## Demonstration

The first stage of the effort was to identify the key strategic airlift-unique requirements and to address them in a demonstration. After several meetings with key Air Force personnel (from AFLC LMSC/SMW, AFLC LOC/AT, AFLC/XRS, and HQ MAC/LGS), unique requirements were identified:

- Model the MAC single war readiness spares kit (WRSK) concept.
- Model the channel route structure.
- Model the concept of lateral resupply.
- Collect and process MAC-unique data.
- Generate MAC-unique measures of merit.

## Single WRSK

Strategic airlift supply system concepts differ from the tactical supply system concepts. One strategic airlift WRSK supports a fleet of cargo aircraft at each home station, whereas a tactical aircraft WRSK is designed to support each unit. Further, each strategic airlift WRSK is segmented, and each segment is designed to support a specified number of landings. There is one base-level self-sufficiency spares (BLSS) kit at each home station to support the home station's predicted flying activity. Thus, in a strategic airlift assessment, SAM would need the capability to locate WRSK segments at specified locations.

## Channel Route Structure

Strategic airlift aircraft fly missions over a channel structure (from Base A to Base B to Base C) rather than flying sorties (from Base A and back to Base A). Since the Dyna-METRIC model is based on sorties, our initial approach (in the demonstration) was to handle the channel by describing landings in terms of flying hours and, then, translating the flying hours into sortie rates. Our approach in the second stage was similar, but the required computations were performed external to SAM.

## Lateral Resupply

One very important aspect of MAC's concept of operations is the lateral resupply of parts from one base to another. Rather than waiting for a part to be ordered and shipped from the depot, parts will be supplied from another base that can fill the need for that part. Dyna-METRIC is not capable of handling lateral resupply so the working group had to develop an approach to modeling this procedure. In the demonstration phase, we were unable to model lateral resupply due to time constraints, but did develop and implement a solution in the second stage of the strategic airlift effort.

## MAC-Unique Data

As part of the demonstration effort, the working group investigated data sources that would be required in SAM to describe the strategic airlift scenario, WRSK/BLSS parts, and stock levels of those parts. Since MAC's concept of operations and their WRSK/BLSS requirements computations are

different from those of tactical aircraft, new sources of data had to be identified.

First, data describing the scenario was identified. Scenario data for tactical aircraft is defined in the War Mobilization Plan-5 (WMP-5) and the time-phased force deployment data (TPFDD). Scenario data for strategic airlift is contained in the output of MAC's flow generator (FLOGEN). Thus, SAM would somehow have to interface with FLOGEN outputs to create scenario data.

Second, data describing WRSK/BLSS parts was identified. MAC computes WRSK/BLSS requirements in a MAC-unique data system; it does not use the Air Force standard D029 system to compute these requirements.<sup>2</sup> Thus, SAM would have to collect parts data through two MAC-unique requirements data systems, Q65 and Q40.

Third, stock data was identified. MAC reports through the combat supplies management system (CSMS), but a key portion of MAC's stock, forward supply system (FSS) items, is not contained in CSMS. FSS stock, which is reported in MAC's FSS data system, is prepositioned at forward supply locations (FSLs) and is very important to MAC operations. Thus, SAM would have to collect FSS stock data through MAC's FSS data system.

### MAC-Unique Measures of Merit

SAM for strategic airlift aircraft would need to display MAC-unique measures of merit. As mentioned previously, measures of merit for tactical aircraft include sorties achieved and NMCS rates. Strategic airlift measures of merit are completely different; they include flying hours achieved, use rate achieved, utilization (ute) rate achieved, and ton-mile capability. Use rate is flying hours per day per aircraft for either a single aircraft or a group of aircraft. Ute rate is flying hours per day per aircraft for an entire fleet of aircraft. Ton-miles indicates the total cargo movement capability of the fleet.

Even though many of these issues were not completely resolved, a strategic airlift capability assessment was demonstrated. An unclassified sample scenario consisting of three onshore and five offshore bases was used. The range of parts was determined by D029, and the demand rates were computed from D029, for onshore<sup>3</sup>, and Q40, for offshore. Stock levels were collected from CSMS and MAC's FSS data system.

After scenario data was translated into Dyna-METRIC (Version 4.4) input data, the model was run. The results showed that, despite poor performance at the offshore bases, SAM could adequately model strategic airlift aircraft if these issues were resolved.

### Production Development

Completion of the demonstration effort led the working group into the second stage on the project—developing and implementing the capability to assess strategic airlift aircraft in SAM production. This effort involved not only the complete resolution of the issues previously mentioned, but automation of several processes that were done manually for the demonstration. The development effort was done in five steps.

### Single WRSK and Channel Route Structure

In the first step, SAM for strategic airlift was developed to handle the assessment of WRSK-BLSS segments of main operating bases (MOB) in CONUS and forward supply stock (FSS) at forward supply locations (FLS) overseas. In the second step, the channel route structure issue was handled outside of SAM in MAC's compilation and computation of the scenario data. This was done for two reasons: it was easier to have MAC compute the scenario from their own FLOGEN output data rather than to transfer the data to SAM to be computed since contractors are not allowed access to FLOGEN or FLOGEN-extracted data.<sup>4</sup> Thus, any computations done in SAM could not be validated by the contractor.

A summary of the computations done by MAC for the scenario is shown in Figure 1. Currently, MAC computes these values manually<sup>5</sup> and enters the data via interactive screens in SAM.

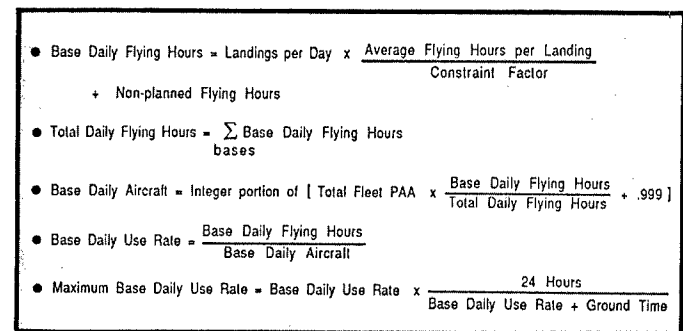

Figure 1: Computations for Scenario Data.

### Lateral Resupply

Third, an approach to handling lateral resupply in the framework of Dyna-METRIC was developed and implemented. A Strategic Airlift Model (STRAT AIR) was then developed which included this modification and several others (specifically in the model output). Based upon a set of decision rules defined by MAC, the lateral resupply approach in STRAT AIR models the relocation of stock from one base to another.

- There is no offshore to onshore resupply.
- An offshore base is a higher priority "donor" than main operating bases and continental US bases.
- Offshore to offshore resupply takes 1 day.
- Onshore to onshore resupply takes 1 day.
- Onshore to offshore resupply takes 3 days.
- There is no lateral exchange of unserviceable items.

In summary, lateral resupply is modeled by first separating the onshore bases from the offshore bases. Then, for each day and item, the algorithm ranks the bases according to an expected on-hand (EOH) quantity, which is the stock level for that item at that base minus the expected pipeline content for that item at that base. Next, the best "recipient" and "donor" bases are selected. The best recipient base is the base with the lowest EOH, and the best donor base is the base with highest positive EOH.<sup>6</sup> Also, the decision rules mentioned previously governing onshore and offshore resupply conditions are considered in this selection process. After each lateral resupply, the process of choosing a donor and recipient is repeated.

## MAC-Unique Data and Measures of Merit

Fourth, MAC-unique data sources to be used in SAM were integrated into the system. Scenario data mentioned previously is compiled and computed by MAC and entered into SAM via interactive screens. Q65 and Q40 are not being used by SAM to describe the WRSK/BLSS because they were not available at the time that SAM for strategic airlift was implemented. D029 is being used in their place. And FSS data is being processed by SAM in order to account for FSS stock at the bases.

Beside these MAC-unique sources of data, several standard Air Force data systems are being used (as in SAM for tactical aircraft), completing the input data requirements: D041 for depot-specific parts data, D042C for engine stock data, D043B for interchangeable and substitutable data, CSMS for base stock data, and D143H for depot stock data.

Finally, MAC-unique measures of merit were incorporated into STRAT AIR and into the SAM output reports. STRAT AIR reports display expected NMCS aircraft, expected flying hours, and expected use rate by base by analysis day.

## Production Implementation and SORTS

SAM production for strategic airlift assessments was implemented on the AFLC worldwide military command and control system (WWMCCS) in January 1987 (Figure 2). With this capability, MAC will be able to report into the status of resources and training system (SORTS). HQ MAC received C-5 production output data in August 1987. C-141 production output is expected by October 1987. The output will be reviewed for validity and any identified problems noted. HQ MAC expects to report in SORTS once problems are corrected and valid. Estimated date for SORTS incorporation is early 1988. Strategic airlift reporting differs from the way nonstrategic airlift aircraft report in SORTS for two reasons.

First, non-strategic airlift aircraft report in SORTS by unit. Since strategic airlift aircraft do not have units per se, reporting in SORTS could be done by either the whole fleet or by a group of aircraft located at each home station. Currently, it is proposed that strategic airlift will report by fleet. Second, C-levels in SORTS for nonstrategic airlift aircraft are determined according to the 30-day cumulative sorties percentage and available aircraft percentage (Figure 3). Since strategic airlift measures of merit are different, it is proposed that C-levels for strategic airlift be determined by use rate percentage.

Thus, SORTS reporting for strategic airlift aircraft presently consists of use rate, available aircraft, and fill rates as compared with cumulative sorties, available aircraft, and fill rates for tactical aircraft. Perhaps in the future, an even better measure of airlift capability such as ton-miles could be added to the SORTS reporting.

With the assessment capability now provided by SAM for strategic airlift aircraft, MAC has a vehicle to not only directly

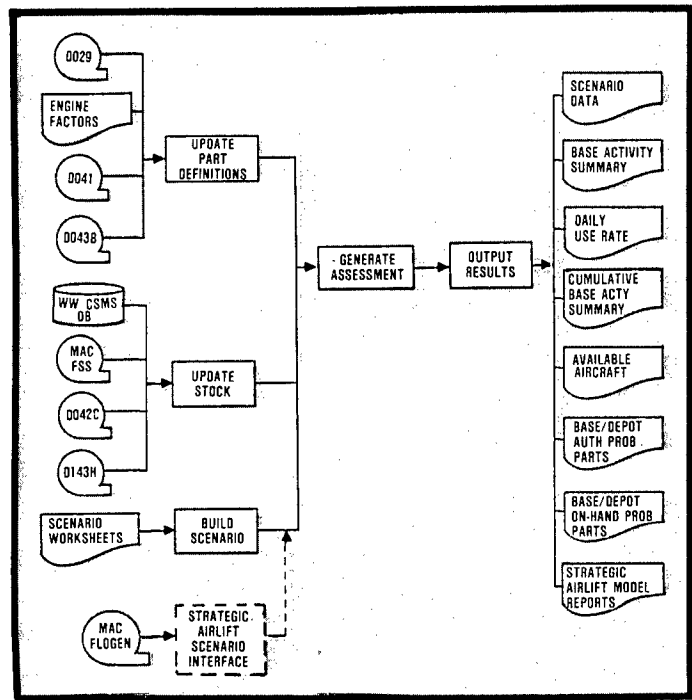

Figure 2: SAM Strategic Airlift System Overview.

C-LEVEL	30 DAY CUMULATIVE SORTIES PERCENTAGE	DAY 30 AVAILABLE AIRCRAFT PERCENTAGE
C-1	90-100%	58-100%
C-2	80-89%	47-57%
C-3	65-79%	37-46%
C-4	0-64%	36-0%

GREEN [checkered] YELLOW [diagonal lines] RUST [solid grey] RED [diagonal lines]

Figure 3: C-Levels in SORTS for Nonstrategic Airlift Aircraft.

report to SORTS but to examine, in an automated way, the predicted performance of strategic airlift. This automated capability marks a large step forward in the area of capability assessment.

### Notes

- <sup>1</sup>SAM outputs for tactical airlift aircraft show use rates instead of sortie rates.
- <sup>2</sup>MAC does report to D029, but it does not compute requirements through D029 as tactical units do.
- <sup>3</sup>Q65 was not used in the demonstration because there was no automated means to process the data.
- <sup>4</sup>Per JCS MOP 39.
- <sup>5</sup>In the future, AFLC LMSC/SMW will be automating these computations. The resulting values will be automatically entered into SAM through the Strategic Airlift Scenario Interface (SASI).
- <sup>6</sup>This algorithm also ensures that the donor base's stock is never depleted to less than three items after a lateral resupply.

AFLC

*"He who knows when he can fight and when he cannot will be victorious."*

Sun Tzu, 400-320 B.C., *The Art of War*, iii

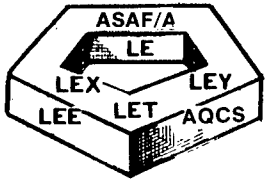

# USAF LOGISTICS POLICY INSIGHT

## Theater Allocation Document

Air Staff is developing a Theater Allocation Document (TAD) to provide budget allocation information to the commands. This document will allow commands to quantify concerns over readiness and sustainability issues. The TAD will show allocations of munitions, spares, tanks, racks, adapters, and pylons (TRAP), and petroleum, oil, and lubricants (POL) by theater for each of the Program Objective Memorandum (POM) years. The TAD will focus on unpowered munitions first, through a document called the Theater Unpowered Munitions Program (TUMP). The TRAP, POL, and spares areas will be tackled after the unpowered munitions section of the TAD is completed and published. The Theater Air Missile Program (TAMP) document already allocates powered missiles to the theaters and is published once a year. These documents should give commands better visibility over their share of assets and their share of the Air Force budget. (Lt Col Gary Lewis, AF/XOXFC, AUTOVON 225-7003 or Margaret Kinhead, AF/LEXY, AUTOVON 225-6730)

## AFR 66-3

AFR 66-3, *Acceleration or Compression of Depot Level Maintenance During Emergencies*, has been revised and was published 27 Mar 1987. In synopsis, this revision changes the terms *aircraft/missiles to materiel* and *mission-essential aircraft/missiles to mission-essential materiel*, using the JCS Pub 1 definitions; adds the terms *general war, mobilization, and unique configuration*; establishes new policies for depot mobilization in instances short of general war, for requesting waivers to AFR 55-55, *U.S. Air Force Reporting Instructions*; and adds responsibilities for organizations exempt from reporting. (Mr Charles E. Hoadley, AF/LEYY, AUTOVON 227-8052)

## AFR 57-4

AFR 57-4, *Modification Program Approval and Management*, has been revised and was published 28 Aug 1987. This revision incorporates major changes to mod classification, mod criteria, responsibilities, and contracting policies. Class IVC mods have been deleted and incorporated into class IVB; AFLC mod approval authority has been increased to \$8M for ground equipment; remaining service life requirements have been increased to 4 years for accomplishment of a modification; and a new limitation on the quantity of allowable class II aircraft mod installations prior to HQ USAF/LEY approval has been added. In addition, language has been clarified for the quick modification concept; guidance has been provided on the use of multiyear contracting; a requirement to limit group B kit procurement to the quantity of aircraft required to accomplish the applicable mission has been added; Air Force Operational Test and Evaluation Center (AFOTEC) responsibilities have been expanded and clarified; new policy on modification alternatives (preferred spares, maintenance actions, and

software only changes) has been included; permission has been granted for message approval of Operational Support Aircraft (OSA) mods; and areas of responsibility have been expanded to ensure sufficient procurement of replacement items. (Mr Charles E. Hoadley, AF/LEYY, AUTOVON 227-8052)

## Software

SOFTWARE!!! Without it the B-1B, C-17, F-16, Peacekeeper, and Over-the-Horizon Backscatter Radar do not function. AFR 800-14, *Lifecycle Management of Computer Resources in Systems*, was revised in late 1986 to help the AF better manage the "software explosion" being seen in weapon systems. If logisticians have not read the regulation, they should. It defines a new partnership between operating and supporting commands in accomplishing the AF software support mission. Command software experts will be working closer together in two important areas: to ensure software supportability is designed into systems being developed and, after the system is fielded, to ensure that mission responsiveness and system integrity are maintained in an environment in which several different organizations will be changing software. (Lt Col Adams, AF/LEYY, AUTOVON 227-5642)

## Tactical Shelters

Within the next five years, the Air Force expects to have an inventory of 1700 tactical shelters, while the DOD will have nearly 10,000. The shelters are all built to International Organization for Standardization (ISO) container specification (8' x 8' x 20') standards. The shelter solves many facility related problems, but its size creates transportability challenges to the DOD Transportation System. Industry is adept at the movement of ISO containers through the surface and air mode. However, military airlift presents numerous problems for rapid through-put at various airfields throughout the world. It is particularly difficult to handle shelters easily and rapidly from their stored locations to delivery for air shipment and vice versa at the ports of debarkation. The Air Force is making significant progress in identifying and procuring a variety of shelter handling equipment to accommodate a significant influx of airlift requirements for these shelters. This increase in capability has resulted from procurement of container side loaders, rough terrain container handling forklifts, contracts for strategic and air transportable container handling equipment, and development of a 60K superloader. In addition, the Army medical community is actively supporting development of a prototype for rough terrain container straddle equipment. (Maj Steve Carroll, AF/LETTC, AUTOVON 227-4742)

## COPARS

Contractor-Operated Parts Stores (COPARS) operate with varying degrees of success throughout the Air Force. They feature readily available contractor-owned parts, which are intended to reduce vehicle downtime and parts cost. Over the

past 20 years, contract terms have been reformatted several times to eliminate weaknesses. Despite all these efforts, the contracts have retained several unfavorable performance characteristics. These include backorder lists that are too long, cost reimbursement (NPL) rates that are too high, inadequate shelf stock, and vehicles deadlined for parts/vehicles out-of-commission (VDP/VOC) rates that are forever on the mind of the vehicle maintenance officer (VMO). Of course, an important consideration is how quickly the contractor delivers parts—a contract pricing element we have generally ignored. The Logistics Management Center will study and develop an incentive pricing arrangement that adjusts the amount we pay the contractor to good or bad results in these and other contract performance elements. The goal is to stimulate improved contractor performance through extra rewards for prompt delivery. (SAF/AQCO, SMSgt Parks, AUTOVON 224-2626)

### AFLC Debuts Productivity Report

Air Force Logistics Command's first command-wide productivity report under the PACER EXCEL program has been completed. PACER EXCEL is the command's response to a 1986 presidential order directing a 20% boost in government productivity by 1992.

The report showed that AFLC's productivity enhancement efforts are working, with the command recording a 2.4% increase from fiscal years 1985 to 1986. The 2.4% figure is likely to change, though, because the first report looked only at the command's maintenance and distribution functions. This number will be recalculated when the program broadens in scope to include contracting, manufacturing, and materiel management functions in the first quarter of fiscal 1988.

Productivity reports are forwarded to Air Force and the Department of Defense Productivity Program Office where report results will eventually become part of an overall government productivity assessment. With 1985 established as the baseline year for tracking productivity, and a goal of 20% increase over a seven-year period, AFLC will need an average increase of 3% a year to keep pace.

Productivity is tracked in AFLC with an "objectives matrix" developed at the University of Oregon's Productivity Center. The matrices developed for use in AFLC simultaneously weight management indicators measuring efficiency, quality, and timeliness. The result is a single, composite index representing relative productivity. Plans and Programs directorates at the command's five air logistics centers and the Aerospace Guidance and Metrology Center are responsible for completing the matrices at the center level and providing quarterly and yearly reports to AFLC headquarters.

► *Continued from 30*

CFR is an easy-to-learn system that simplifies the FR process. It is 100% consistent with the FR manuals and generates higher quality debriefings and more accurate aircraft status. There is some aircrew resistance, but improvements to software and hardware should lessen their concerns.

### Conclusion

We have a potentially great technological advantage with our newer weapon systems, but we are not achieving their full design capabilities. (This is not to say they need to be 100% perfect, but we must have confidence they can fully perform

PACER EXCEL encourages unit managers to improve the way they use resources in accomplishing the AFLC mission while discouraging "over the shoulder" micromanagement by headquarters staffs at command, Air Force, and DOD levels.

### Quality Contractors to Receive Consideration on DESC Business

Low bid may no longer be the bottom line when the Defense Electronics Supply Center (DESC) decides who gets its contracts for component parts. DESC is establishing a quality vendor program which will permit it to weigh product quality and delivery as well as price when awarding contracts for electronic material.

The program is one of the first major initiatives introduced under DOD's new Pilot Contracting Activity Program. The DOD program encourages major procurement centers such as DESC to seek better ways to do business, largely by employing methods more in line with commercial practice. By emphasizing quality, delivery, and price as award criteria, DESC expects to begin implementing a more commercial style of competition.

Under the new concept, contractors who apply and can demonstrate they have provided DESC with dependable quality and delivery may be eligible for procurement awards even when their offer is as much as 20% over a low bidder not classified as a quality vendor.

DESC is establishing quality vendor lists for five commodity groups: miscellaneous communications equipment; antennas and waveguides; synchros and resolvers; semiconductors; and microcircuits. Historically, price has been the most significant factor in determining successful bidders. Now, however, federal acquisition regulations allow procurement staffs to consider other criteria such as quality when making awards.

Three general qualifications are required before a firm can be placed on a quality vendors list—three contracts in the given commodity class over the past year (value of merchandise exceeding \$10,000); a 90% or higher on-time delivery; and a documented acceptable level of quality. (Mike Lyons, DESC, AUTOVON 986-6264)

### MITLA

The Air Force has recently accepted the lead role in developing an overall DOD-wide program for microcircuit technology in logistics applications (MITLA). It is working in close coordination with the other Services and the Defense Logistics Agency (DLA). (Mrs Jane Channell, AF/LEXY, AUTOVON 227-4955)

the next mission as well as the last.) We must accept the problem for what it is—systems are too complex to manage in the traditional ways. We must use our current tech data and maintenance data collection systems to their fullest extent. And, finally, we must aggressively pursue acquisition of systems with capabilities like the F-15 CFR, provide interfaces between aircraft and information systems, and furnish the infrastructure to field them properly.

#### References

1. Air Force Logistics Management Center. *Evaluation of Fault Reporting & Fault Isolation (F-16)* by Captain Gary Gemas, AFLMC Project LM831206, June 85.
2. AFLMC Report. *F-15 Computerized Fault Reporting*, AFLMC Project LM850125, July 1987.

**AIS**

# Power Projection Through Airlift - How to Make It Work

Major David F. Todd, USAF  
Faculty Instructor  
Air Command and Staff College  
Maxwell AFB, Alabama 36112-5542

The sun began to peek over the Sahara desert as Colonel Muammar Gaddafi entered his command tent. The enthusiasm of his battle staff had been high the night before. However, this morning it was just the opposite. Within the last 24 hours, United States military reconnaissance and intelligence aircraft had arrived in Egypt and Sudan. Now on station, these aircraft were gathering intelligence and early warning data on Libyan forward deployed units. Libyan tactical surprise for an invasion of Sudan had been lost. The senior Soviet advisor to Libya turned to the Colonel and stated: "Not today comrade, not today."

This scenario could happen, and did happen in 1982. (2:28) The rapid deployment of United States Air Force assets provided the intelligence and early warning that denied the Libyans tactical surprise and gave Egyptian and Sudanese forces essential air and land order of battle information. Without tactical surprise, Libya could not carry out its planned aggression.

**"The ability to project combat forces is a national asset; and this capability, when used correctly, can achieve policy ends without a shot being fired."**

The United States often uses military power projection for the purpose of influencing both friend and foe. Between 1975 and 1982, United States forces deployed to show support for an ally or stood ready to confront a foe on 44 occasions. These deployments used airlift 26 times for the rapid projection of forces. (3:46-48) The ability to project combat forces is a national asset; and this capability, when used correctly, can achieve policy ends without a shot being fired. The ability to "show the flag" in these instances demonstrates to friend and foe alike our national resolve.

While a Special Airlift Director at Headquarters Military Airlift Command (HQ MAC), I was involved in several airlift operations that projected US power worldwide. These operations covered a wide spectrum of power projection options: deploying US forces into combat, transporting allied forces, delivering security assistance equipment, and providing humanitarian relief for famine and natural disaster. However, there were several occasions when a misunderstanding of airlift capabilities almost doomed the operation. The purpose of this article is to create an awareness of the limitations and constraints of airlift so that short-notice airlift operations can be improved. And, essential to an awareness of airlift operations is a basic understanding of the airlift request system.

## Airlift Request System

The airlift request system is simple and straightforward, and provides a framework to collect essential airlift information systematically and disseminate that information to activities that need to know. Following is a broad brush explanation of the airlift request system. The details and specifics of this system are found in AFR 76-38/AR 59-8/OPNAVINST 4630.18E/MCO 4630.6D/DLAR 4540.9, Department of Defense (DOD) Common User Airlift Transportation. Nearly all force projection operations using airlift are accomplished by Special Assignment Airlift Missions (SAAM). By definition, these are missions operated by MAC to satisfy a requirement needing a special pickup or delivery at locations not established within the approved DOD channel structure, or to satisfy a requirement needing special consideration because of the unusual nature, sensitivity, or urgency of the cargo and operation. (4:1-3) There are two types of airlift requests: routine and contingency.

### Routine

Routine airlift requests are handled in a straightforward manner (Figure 1). The user requests airlift transportation using a DD Form 1249, SAAM or JCS Exercise - Airlift Request, which is forwarded to higher headquarters for approval. Before MAC can schedule aircraft against this request, it must be approved by the user's validator. The validator is usually at the major command or service level transportation office. After the validator has approved the request, it is forwarded to an airlift executive agent. For an intratheater (within theater) airlift request, the request is forwarded to the theater airlift executive agent. For all international commercial aircraft, intertheater (between theaters), and continental United States (CONUS) airlift requirements, requests are forwarded to HQ MAC.

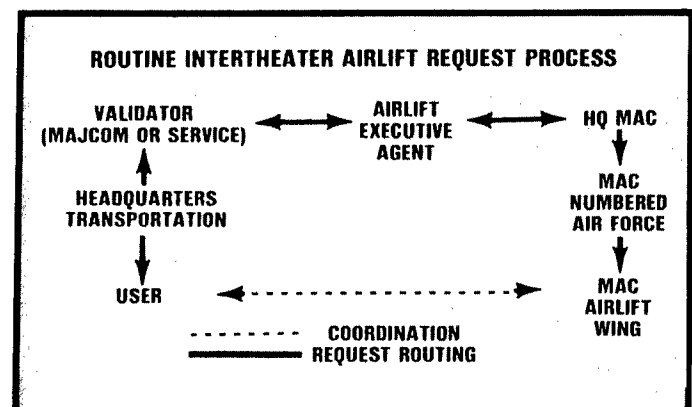

Figure 1.

## Contingency

For a contingency airlift request, the validator system is still in effect, only now the process expands. The Joint Chiefs of Staff (JCS) direct operations by tasking services or other commands to support a Unified Command. This tasking could be in the form of deploying augmenting military forces to a theater or by sourcing and transporting military equipment, trainers, or advisors to an allied country. In either case, it is the responsibility of the supporting command or service to arrange transportation. The supporting command's validator or supporting service's validator must gather information on the unit to be transported and forward that data to HQ MAC (or theater airlift executive agent) in the form of a validated airlift request (DD Form 1249). From this point on, the contingency airlift request is processed in the same manner as a routine airlift request. When the Joint Deployment System is used to coordinate a deployment operation, the validated airlift request is handled as a part of the time-phased deployment list. The request system expands to handle any contingency.

## Limitations and Constraints on Airlift Operations

Many decisions are made that affect an airlift operation. Users have the prerogative to specify certain parameters in the airlift request. By the same token, the airlift director must balance many different user airlift requests to ensure support for as many of these requests as possible. Thus, flexibility is necessary on the part of both the user and the airlift planner to accomplish the mission, because airlift resources are limited and always in high demand. (9)

In any airlift mission, the old equation of who, what, where, when, and how applies. The user specifies the what, where, and when in the airlift request, by specifying the cargo type, onload location, delivery point, and time constraints. With that information, the airlift director formulates how the mission will be accomplished and who will perform it. In order to make these critical decisions, the airlift director weighs several limitations and constraints which can be categorized as airfield limitations, airlift force management, and flight constraints.

### Airfield Limitations

Two major concerns for an airlift director are the limitations of the aerial port of embarkation (APOE), or onload location, and aerial port of debarkation (APOD), or offload location. These locations are specified by the user as the place passengers and cargo are to be onloaded and offloaded. These locations often restrict airlift operations for a number of reasons. First, the airfield must be suitable for MAC aircraft. MAC maintains a listing of thousands of airfields worldwide that have been surveyed for safe C-130, C-141, and C-5 aircraft operations. MAC aircraft may not be able to operate into some airfields because of weight bearing restrictions or length or width of a runway or taxiway. Constraints caused by airfield restrictions can be worked around by scheduling flights with smaller load factors or using smaller aircraft. But just because aircraft can land at the APOE or APOD does not necessarily mean that the operation is unconstrained. Aircraft may be restricted to daylight operations because of the lack of adequate lighting or other airfield hazards. The airfield might not have fuel or onload/offload equipment available. An airfield might be restricted by local authorities for a number of

reasons—quiet hours, customs and agricultural inspections, or airfield construction. The maximum number of aircraft on the ground, or MOG, may restrict flights into the airfield or the rate of delivery for airlift missions. An airfield with an offload MOG of five means there can be five aircraft on the ground at once, offloading at the same time. Thus, assuming approximately three hours turnaround time per aircraft, we could deliver five loads of passengers and cargo every three hours. With a MOG of one aircraft, the same offload requirement (five equivalent loads) would take approximately 15 hours to deliver. Therefore, the selection of an APOE and APOD must be made with care. The user must realize the selection imposes restrictions on the airlift director and either be willing to live with the restriction or modify the airlift requirement. Having determined the suitability and restrictions of the airfields involved in the operation, the airlift director must consider airlift force considerations.



MAC C-141 redeploying American troops after OPERATION URGENT FURY.

### Airlift Force Management

Airlift forces available to project US power worldwide are large. Unfortunately, they are not large enough to satisfy all airlift requests. Therefore, airlift directors are restricted by the airlift priority system in evaluating an airlift request. JCS PUB 15, *Mobility Systems: Policies, Procedures, and Considerations*, describes the priority system. The airlift system is a dynamic one in which the number of aircraft available to support requested missions fluctuates daily. As an example, MAC possesses approximately 210 C-141B aircraft. (6:4) Of that number, 70% to 75% are committed for training and operational missions. (6:4) The aircraft remaining are usually not available due to maintenance. (8) Available aircraft are always committed to support someone; therefore, when a short-notice request is made, it may be at the expense of training or another airlift user. The airlift system can surge to accommodate a crisis situation, but the day-to-day airlift system and MAC's worldwide commitments do not stop. General Thomas Ryan, former CINCMAC, described this when asked about OPERATION URGENT FURY:

Grenada required a lot of our attention but we did not stop everything else that we do. We continued to support several major joint exercises: BOLD EAGLE, REFORGER, and AHAUS TARA II. We are still heavily involved, of course, with the Lebanon crisis. Following the bombing of the Marine battalion landing team, MAC provided aeromedical evacuation as well as 13 C-141 sorties to bring in new

people and maintain day-to-day logistical resupply. We did not back off from any of our other responsibilities.

The net result, through this period, was a very high level of activity for the entire command. We surged to almost an 88 percent aircraft utilization on the C-141s, which is considerably above the normal utilization of approximately 65 percent. As many as 220 aircraft were flying around-the-clock to support all our world-wide missions. It was a very busy period but the command did very well. (1:5)

A dynamic airlift system can accommodate short-notice requirements, but aircraft availability is only one aspect of the airlift force. Another factor is availability of trained aircrews.

Certain missions may require specially qualified crews (airdrop, air refueling), and these aircrews may not be available. For example, only 30% of the C-141 aircrews are airdrop qualified. (6:3) Having the proper crew in the correct location also takes planning. Strategic airlift operations from the CONUS to worldwide locations require MAC to preposition aircrews at overseas staging bases. These aircrews relieve those that bring the missions from CONUS to the en route locations, and stage crews continue the missions to the final destination. Since all C-141 and C-5 aircrews are home based in the CONUS, staging crews must be transported with enough time for crew rest prior to the arrival of the airlift missions. For certain theaters, the decision to position stage crews may have to be made 48-72 hours prior to the airlift operation. Finally, prior to execution of an airlift mission, the airlift director evaluates flight constraints.

### Flight Constraints

A number of factors determine flight constraints. First, what en route stops must the aircraft make prior to the destination? Can the en route location support the aircraft by providing maintenance and fuel? If the en route locations are unacceptable, is air refueling a possibility? Does the mission, due to flying time, need to be staged with extra aircrews? After the offload at the APOD, where will the aircraft recover? Is it required for another mission? Must the aircrew enter into crew rest or proceed to another stage location? Can diplomatic clearance be obtained in time to accomplish the mission? Some countries require 10-14 working days to approve overflights.

***"The airlift director always evaluates an airlift request with regard to the three categories of limitations and constraints: airfield limitations, airlift force considerations, and flight constraints."***

The airlift director always evaluates an airlift request with regard to the three categories of limitations and constraints: airfield limitations, airlift force considerations, and flight constraints. Seemingly minor points can have a major impact on an airlift operation. An example of this occurred in TEAM SPIRIT 86.

During the redeployment of forces from the JCS exercise TEAM SPIRIT 86, a volcano erupted in the Aleutian Islands. Volcanic ash from the eruption closed Elmendorf AFB, Alaska, to flight operations during the redeployment. Elmendorf was a major staging base for the exercise and with it closed, the redeployment flight routing had to be reworked.

Exercise airlift directors decided to run the missions through Hickam AFB, Hawaii. A simple decision, but the impact on the redeployment was enormous. Additional aircrews were sourced and transported to Hickam to establish a stage. Additional support personnel were needed to handle the increased flight activity. This additional workload posed a significant problem for host base services (billeting, fuels, maintenance, loading support, food services) as well as airfield management, air traffic control, US Customs, and Department of Agriculture. Effects of the volcanic eruption could be felt not only in Alaska and Hawaii but also within the MAC system. To set up another stage location took time and impacted the redeployment schedule. For 48 hours the turbulence in the MAC system in the Pacific was dramatic. This turbulence impacted regularly scheduled airlift in the Pacific as missions were diverted to support TEAM SPIRIT 86. (7:1)

### Factors That Adversely Impact Airlift Operations

The complexities of airlift operations, particularly short-notice operations, can be many and varied. Problems in the initial request phase may adversely impact an airlift operation and limit its chances of success. These problems may include inadequate response time, misunderstanding mission support, unclear tasking, or rapidly changing requirements.

### Response Time

One of the most common misunderstandings in the joint community is over response time. Even though airlift can traverse intercontinental distances in hours, MAC still needs time to plan and prepare for a major airlift operation. The airlift system can accommodate the "in-system select" or diversion of a few aircraft to perform a short-notice mission. However, for the system to generate multiple missions, time is needed to accomplish several critical actions:

(1) *Select aircraft and crews.* MAC does not keep aircrews or aircraft on alert continuously and must select aircraft and appropriate crews which can best accomplish the mission. Aircraft must be mission capable and aircrews have proper crew rest. When will deploying forces and equipment be able to move? What is the best mix of available aircraft to move the cargo efficiently?

(2) *Plan and coordinate an airlift flow.* In other words, MAC needs time to plan the most efficient and effective use of airlift aircraft. Some questions which must be answered: Are the APOE and APOD locations suitable for airlift aircraft? What, if any, are the restrictions or operating hour constraints at those airfields? Is onload/offload equipment available at the APOE and APOD? If not, do we position an airlift control element (ALCE)? Where does the ALCE come from and do we have time to preposition it?

(3) *Flight route planning.* How do we route the aircraft? Can we request and receive the diplomatic clearances needed to overfly countries en route and land at the destinations? What countries must we avoid? Where do we position aircrews for staging? Where do we refuel? Are we going to air refuel en route? What are the airborne and ground threats?

These items are just "the tip of the iceberg" for actions required to plan and execute airlift operations in support of a contingency. For the most part, nearly all planning and preparations can be done within 27 hours of notification from

the validators. This is not an arbitrary figure. This amount is required to allow MAC to accomplish the planning necessary to establish an *efficient* airlift network. (It is interesting that during contingencies, MAC aircraft frequently arrive at the onload location only to find the user is not prepared to depart.) (9)

***“MAC always wants as much time as possible to prepare for a contingency operation, but the desired minimum is 27 hours from request notification to departure of the first military aircraft.”***

MAC always wants as much time as possible to prepare for a contingency operation, but the desired minimum is 27 hours from request notification to departure of the first military aircraft. As expected, lead times can vary widely depending on the airlift request. The more time the user gives the airlift director to work a request, the more responsive and effective airlift can be. Even a “heads-up” on a forthcoming request will get the airlift machinery rolling to analyze the limitations and constraints on the potential operation.

### **Mission Support**

Another area of misunderstanding by airlift users is over mission support and the ALCE. MAC determines, depending on location and mission, what onload and offload support is needed to accomplish the mission. MAC does not always have the luxury of operating into the best airfields and often has a requirement to operate into a bare base without in-place mission support. For large operations, mission support may include a command element, maintenance, transportation, communications, weather, and other support activities. If host base equipment or facilities are available, MAC will attempt to use them and may only need to send in a few people to coordinate this support.

Sometimes MAC is constrained by higher authority when selecting the number of people or type of equipment needed to support a particular mission. If this happens, the user can expect an adverse impact on the airlift operation. MAC’s goal is to deploy only what is required. ALCE personnel and equipment support many missions and MAC cannot afford to send in a “fat” ALCE. Mission support is just that—the minimum essential personnel and equipment to support the airlift operation.

### **Tasking**

MAC usually does not commit aircraft or aircrews to a mission without a validated airlift request. (9) Numerous times MAC hears: “This is a JCS tasking. Can’t MAC make an exception?” While MAC strives to respond to user needs, established procedures serve an important function: the orderly and systematic coordination of information to several agencies who work together to provide airlift services. Airlift request procedures were established and are practiced so contingencies are more easily worked. Exceptions could result in increased workloads for an already busy contingency management staff and increase the probability that critical information would not reach the necessary people in a timely manner. As was

discussed earlier, MAC forces are always committed to a mission. Withholding these forces, for an unvalidated mission, denies another user of needed airlift support. Established procedures, if practiced routinely, will reduce confusion during a contingency operation and will add to the effective use of a vital national asset.

### **Changing Requirements**

One of the most frustrating things that confront contingency airlift directors is changing requirements. The planning and coordination of a contingency staff can be invalidated by changing airlift requirements at the last minute. For example, changing the onload location causes the airlift director to re-evaluate airfield restrictions, suitability, and supportability. Changing the offload location requires the director to (1) re-evaluate not only the restrictions, suitability, and supportability, but also the payload due to these restrictions, and (2) possibly change the recovery base or the size and makeup of the ALCE. However, MAC planners realize that contingency operations are fluid and changes are inevitable. Major changes to airlift requirements have a catastrophic effect on contingency airlift operations and may delay the effective use of airlift resources (aircraft, aircrews, and support elements). Particularly during a contingency, can MAC ill-afford to misuse airlift resources.

### **How to Eliminate Adverse Factors**

One action, above all others, will help improve strategic airlift operations: Coordinate closely with MAC and, if required, ask for airlift planning assistance at the very beginning of execution planning for a deployment. Many projects are very sensitive, but airlift directors have the appropriate clearances and, if necessary, can travel to the user location to assist in deployment planning. Also, MAC works many “what ifs” based on a secure conversation with JCS and unified commands. Either way, the sooner MAC airlifters are advised of a situation, the more time they will have to do a better job in contingency airlift planning.

An example that illustrates this point was the deployment of Pershing II missiles to Germany. In November 1983, the German Government was voting on allowing US Pershing II missiles into Germany. DOD wanted to deploy the missiles as soon as an affirmative vote was announced. Initial discussions



**Camouflaged C-5 en route to overseas destination. Worldwide C-5 operations are often constrained by airfield limitations.**

*Continued to 41* ►

---

---

## Military Construction: Time for a Change

Colonel Donald J. Thomas, USAF  
Deputy Chief of Air Force Construction Division  
Directorate of Engineering and Services  
HQ USAF, Washington, D.C. 20330-5130

---

---

The President, the military, and, in particular, the Air Force have received a great deal of criticism for what the newspapers characterize as waste and mismanagement. From the procurement of hammers to the development and production of the B-1B bomber, the military has been portrayed as, at best, being inept or, at worst, of covering up procurement failures to protect their positions. As a result, the President formed a Blue Ribbon Commission on Defense Management:

... in part because public confidence in the effectiveness of the defense acquisition system has been shaken by a spate of "horror stories"—overpriced spare parts, test deficiencies, and cost and schedule overruns. (1:1)

Many in the military feel this indictment is blown out of proportion. Yet, they are quick to denounce "the system" which, among other things, takes months to buy a common item like carpeting for offices.

The system which is used to buy new facilities for the Air Force is just as likely to draw similar negative comments from those in the military. The system takes years to build a relatively simple facility. Even the most understanding commanders are frustrated by the red tape and stumbling blocks the system puts between them and new facilities. What is even more damning is that the very people who are charged with operating the system—the engineers, contracting officers, and contractors—are just as frustrated with the mounds of paperwork and seemingly illogical procedures they must follow.

***"Maintain centralized control, but delegate authority and responsibility down to the lowest possible level."***

Although the recommendations of the Packard Commission Report are intended to improve the acquisition of weapon systems, several can also be applied to facility acquisition improvement: (1) streamlining procedures, (2) baselining (making individuals responsible for their actions or inactions), (3) increasing use of technology, (4) using more commercial products, and (5) improving the quality of acquisition personnel. The following discussion of the Air Force Military Construction Acquisition System was motivated by these five recommendations.

### What Needs To Be Done

There is a common thread to many of the facility acquisition system problems. Those who are charged with administering the system are told both what to do and how to do it. If a

mistake is made, the solution has been to issue more instructions on tighter administration of the system. The result has been a management system which stifles initiative and rewards conservative solutions. Similar problems in other functional areas have been recognized by Air Force leaders and the good news is that improvement is possible.

... productivity is not driven so much by the quality of management decisions—important as those may be—as by the quality of the execution. I am totally convinced ... that we not only get more productivity from decentralizing responsibility and authority, but we also get smarter decisions from the commander or supervisor on the scene. (2:44-45)

This quote from General Larry D. Welch, Chief of Staff of the US Air Force, is only one of many made by present and recent leaders of the Air Force who advocate "centralized control and decentralized execution." The following recommended improvements to the facility acquisition system are based on this overriding guideline: maintain centralized control, but delegate authority and responsibility down to the lowest possible level.

### The New Planning Phase

Any good system should begin with a statement of objectives and their priorities. From these prioritized objectives, a listing of requirements can be developed. By knowing the priorities of the objectives, requirements can also be easily prioritized.

There is not a strong tie between Air Force objectives and the facility acquisition program. Otherwise, it would be a relatively easy matter to determine dollar cost for these objectives and establish a budget bogey for the facility plan. If such a plan were devised, there would be less wasted effort and no adversarial relationships, and the product would be available in the shortest possible time at the least cost. The challenge is how to execute such a plan while maintaining control at the appropriate level.

A broad statement of objectives could begin at the Air Staff, Office of the Secretary of Defense (OSD), or even higher. For example, Representative W. G. Hefner, Chairman of the House Appropriations Subcommittee on Military Construction, recently said:

It was this committee that last year saw to it child care centers, family housing, and schools were funded, not the leaders in the Pentagon. We would like to see some priorities set around here, and we want you to take the message back to your leaders. (3:42)

---

(Col Thomas was an AWC student when he wrote this paper.)

Reduced resources will not make it any easier to obtain needed facilities no matter what the priorities are. Gramm-Rudman will ensure the construction budget bogey will not grow significantly in the foreseeable future. If Air Force objectives are to be met, the planning and facility decisions (control) must be devised to match dollars available and allocated accordingly. For example, if an objective is to provide adequate child care centers for eligible dependents, then a facility plan can be devised to accomplish that requirement in two, three, or whatever number of years the objective may be. If Congress does not agree to the objectives or does not agree to provide the funds required, the objectives must change to reflect these decisions. In any case, the various objectives must be prioritized and available funds allocated to meet these priorities.

After objectives are set and prioritized, the next step is to delegate responsibility and authority for their execution. Wing commanders are closest to base problems and are the individuals who, as they develop their five-year plans, must ensure these plans support higher headquarters objectives and policies. The base five-year facility acquisition plan should state wing objectives in terms of higher headquarters objectives and facility requirements needed to meet these objectives.

***“The major organizations on base should have their own mini-Facility Utilization Boards to set objectives and to prioritize requirements within their own areas of responsibility.”***

As a start in developing a wing five-year plan, the major base organizations (for example, the Director of Operations, Chief of Maintenance, Group Commander, and Chief of Resources) should have their own mini-Facility Utilization Boards (FUB) to set objectives and to prioritize requirements within their own areas of responsibility.

Their requirements should be discussed with an individual from the Base Civil Engineer's Programming Section. In fact, each major base organization should have an individual from the Programming Section assigned as an advisor to help them develop their facility requirements and to prepare the necessary paperwork. Such a relationship will help to develop a sense of shared responsibility between the engineering advisor and the user.

The mini-FUB solves several weaknesses in the present system. First, it forces major wing managers to review and set priorities on their own requirements. Second, it allows responsibility for setting priorities to be tied to an individual, and not to the system pinpointing accountability. Third, it gives the action officer who has been working a requirement “face time” with the boss. The action officer could receive recognition for a job well done or the responsibility for not being adequately prepared which again emphasizes accountability. This would be especially true if there were other action officers presenting other projects. An additional benefit would be to help eliminate the adversarial relationship between the civil engineering programmers and facility users.

Only the top four or five base facility projects should receive any in-depth analysis to prevent waste of scarce engineering time. Facility Working Groups should then meet to discuss objectives and the facility requirements which help meet these

objectives. The process would be time consuming the first year. However, in subsequent years, it would be less so because the process would be evolutionary not revolutionary.

## **The New Programming Phase**

The wing FUB is probably active at most bases, but very few have a listing of base objectives in priority order which can be used as a basis for prioritizing facility requirements. Prioritized wing objectives would be a clear statement to the entire wing population of the importance the wing placed on its various requirements. Wing commanders could no longer have five priority 1 projects. They could not tell the Senior Enlisted Advisor that dorm improvement was the top goal and then rank it number 5 on the objectives list.

Many long-range facility construction plans (five-year plans) have often lacked stability because of the relatively short time (usually less than two years) wing commanders are assigned to wings. They are certain to be reassigned before the changes they make to a long-range program are felt by the wings. The possibility of extending wing commanders to benefit or suffer from their facility decisions is very unlikely. One way to help ensure their facility decisions are given the thought they deserve and still maintain execution authority at the base level is through a formalized review process (control) by the major command (MAJCOM).

Headquarters Tactical Air Command (TAC) is already using an annual Military Construction Program review as an informal method of improving a wing's long-range plan. During this review, Civil Engineer representatives from each base brief their five-year facility acquisition plans to the TAC engineering staff. The review has been beneficial to both the base and the staff as each gains a better understanding of base requirements and how they can best be met.

Such an annual review needs to be adopted by all MAJCOMs and taken a step further. MAJCOM control should increase. This increased control could be in the form of an annual facilities briefing by the Wing Commander to the MAJCOM Commander and by the Base Civil Engineer to the MAJCOM Civil Engineer. Wing facility objectives, how these objectives tie to MAJCOM and Air Force objectives, and the rationale for changes to the long-range plan should be briefed. Such a requirement will help ensure changes are given appropriate thought and that the MAJCOM understands the basis for each change.

Just as wing leadership is held responsible for prioritizing their facility construction program, the MAJCOMs should also be held responsible for prioritizing their priority list to a much greater degree. Some commands use a system which ranks the first priority of each base at the top of the MAJCOM listing and then the second priority from each base. The problem with such a system is that priority 2 or 3 at base “X” may be more important to the command than priority 1 is at six other bases. Peters and Waterman in their book, *In Search of Excellence*, point out a problem with such an “analytical” approach:

A buried weakness in the analytic approach to business decision making is that people analyze what can be most readily analyzed, spend more time on it, and more or less ignore the rest. (4:44)

A procedure which requires the MAJCOM to make a decision as to which project is more important to the command should be no harder than it was for the wing commander to decide which project was more important to the wing. Such a

procedure will take more work and discussion to develop—and it should. The result should be well worth the effort and will lend greater credibility to the facility priority system.

The present system of developing a MAJCOM priority listing only warrants discussion of individual projects at the point where the bogey does not permit funding. In other words, if a project is in the "funded area," it makes little difference whether it is priority 1 or 31. That is until the bogey is later reduced and priority 31 is no longer in the funded area (high enough on the priority list to be funded). A system is needed which requires the MAJCOM to take the responsibility to decide which projects are more important to the command and then to publish this list. Currently, command priority lists are close hold, and it is very unlikely that a base will be allowed to see how its projects rank with another base's projects. This allows MAJCOMs to avoid open discussion on the command priority list.

To implement a more realistic approach to prioritizing projects, criteria need to be developed which weigh the need of one base against another for similar facilities. For example, TAC used the number of eligible airmen forced to live off base due to the lack of dormitory space as one of the criterion to determine which base was to receive priority for dormitory construction.

Such a system would not take away the prerogative of the wing commander to decide what is most important for the base. What this system would do is to require the MAJCOM to decide which projects are most important to meet the objectives of the command as a whole. Who is more qualified to make this decision than the people who have the opportunity to compare conditions at all bases? Accompanying the authority and responsibility of setting priorities is the responsibility for MAJCOMs to stand up and explain their decisions and to allow for discussion and dissent. When discussion is over, only the list of priorities and each MAJCOM's rationale should be sent to the Air Staff—not the full documentation. The full documentation should stay at the MAJCOM and it should be held responsible for project validity. The MAJCOM's rationale for the priority listing should accompany the listings and explain how the listing reflects the objectives set by the Air Staff or higher authority.

***"The Air Staff should have the responsibility of setting objectives and passing them to the MAJCOMs, establishing MAJCOM bogeys, and reviewing the line item priority listing of projects."***

Moving to a higher command level, the Air Staff should have the responsibility of setting objectives and passing them to the MAJCOMs, establishing MAJCOM bogeys, and reviewing the line item priority listing of projects. The Air Staff would consolidate MAJCOM priority listings and submit them to OSD to be included in the DOD and finally the President's Budget. The budget submitted to Congress should only include a construction cost by MAJCOM or by "objective."

The construction request for DOD, including \$2.5 billion in Family Housing operation and maintenance (O&M), is about \$10.1 billion or 3% of the total military budget for 1988 and is not projected to increase dramatically in the near future. (3:42)

Why then should Congress spend so much of its time and the Services' time reviewing individual projects? The accusation has been made that the laborious review is for the political attention which can be gained from criticizing the military or to ensure construction funds are spent in favored congressional districts. If these are not the reasons for the review, and Congress truly wants to reduce military cost, then there are other alternatives to a project-by-project review. For instance, Congress might question objectives and priority of objectives rather than digging into the minutia of how these objectives are to be obtained.

One alternative method of overview without overkill would be for Congress to approve facility construction funds by broad categories within a service or MAJCOM. A MAJCOM facility acquisition program could then be divided into categories. The category to which a facility is assigned would depend on the facility's contribution to the mission. For example, one grouping could be direct mission support facilities (runways, fuel storage areas, or munitions storage areas). A second grouping might be mission support facilities (control towers, maintenance hangars, or supply warehouse). A third grouping could be other support facilities (squadron operations, transportation maintenance, or administrative facilities). The fourth grouping could include quality of life facilities (dormitories, dining halls, or physical fitness centers).

To submit four categories per command instead of one would reduce the workload significantly at all levels of command and might be more acceptable to Congress. This is especially true if the groupings included the Air Force's objectives for the program. A prime result of doing business this way is that the Air Staff could return to its primary mission—developing strategy, policy, and objectives. Equally important, Congress could return to its primary function—broad control of the budget process. The potential savings in manpower are significant for both the Air Force and Congress. However, if Congress is unwilling to reduce its project-by-project review of the military construction program or is reluctant to reduce excessive directives for political reasons, MAJCOMs should still accept responsibility for validating base facility requirements and cost estimates and for assigning priorities based on overall MAJCOM and Air Force objectives.

### **Better Cost Estimating**

For Congress to have the faith in the Services' ability to execute the facility acquisition process with less control, a better cost estimating system is needed which more accurately identifies the costs and benefits of construction. Just as the Army is doing, and the Air Force is starting to do, all facility cost estimates should include the cost to operate and maintain a facility throughout its life in addition to the cost of construction—a process known as life cycle costing. The MAJCOM should be responsible for validating these cost estimates and the claimed benefits.

New civil engineering computer systems should be used to gather data to validate life cycle cost estimates using data that is already stored in the form of work accomplished on similar buildings. Both the Work Information Management System (WIMS) computer and the Energy Monitoring and Control System (EMCS) can and should be used to monitor the cost to operate, maintain, and repair a facility. Only MAJCOMs can validate the need or benefits that bases will receive. This validation should not and cannot be done at the Air Staff. MAJCOMs are closer to the problem and should have a much

better appreciation for the need and the expected benefits. The individual at the MAJCOM who does validate a requirement should sign a document attesting to that need which should be maintained as a part of the project record. The system could thus identify the individual responsible for the decision.

## **The New Execution Phase**

### **Streamlining**

Execution of authorized and funded construction programs should also be centered at the MAJCOM. This concept is now being tested at several bases and should be implemented Air Force wide as soon as possible. The test includes eliminating the Air Force Regional Civil Engineer (AFRCE) layer of management from the facility acquisition system. Under the new system, the MAJCOM deals directly with the Air Staff, the base, and the design/construction agent. In short, the command serves as the focal point for the facility acquisition program. This is a major step in streamlining the system because it eliminates an administrative layer and improves communications between the base and the construction agent.

### **Baselining**

One of the most valuable Packard Commission recommendations is to use "baselining." Baselining is a process similar to using milestones (significant points during the acquisition process) to gauge progress and to hold an individual responsible for meeting the dates set to complete each milestone. One important benefit of baselining is that the individual responsible for the work helps develop and agrees to the baseline schedule. The second important benefit is that after the baseline is established, an individual is given the authority to execute the plan without interference including the requirement for time-consuming progress reports.

In the case of facility acquisition, it would be impossible to make one individual responsible to develop the requirement, obtain the funds, design the facility, and then build it. However, it is possible to break down the acquisition process into smaller parts and assign individuals responsibility for various phases of the process.

The Base Civil Engineer could assign a liaison officer to the user's organization. The liaison officer would help the user prepare the requirement and justification in the proper format for programming documents. These appointments of project officer and liaison officer would give each a stake in ensuring the success of a project which would reduce any adversarial relationship.

At MAJCOMs, an individual could be assigned to review, validate, and prioritize all facility requirements of a particular type such as direct mission support, mission support, or other support facilities. Another individual could be assigned to determine what part of the MAJCOM facility construction budget would be spent for each type facility.

### **Increasing Use of Technology**

In addition to new procedures for streamlining the system, other changes should be made. The Packard Commission recommended the use of technology to reduce costs. A significant step in reducing overall cost of a facility could be realized through use of life cycle costing to select facility options. Computers now being installed in civil engineering organizations worldwide can use data already available to

evaluate and validate life cycle cost estimates. There are also many other ways the computer can help to reduce facility costs.

Computers should be used in the design process to verify heating and cooling requirements for special use facilities such as Precision Measurement Equipment Labs. Likewise, the structural design of facilities can be refined using commercially available computer software. Computer programs are available to determine heating and cooling cost variants caused by structural considerations such as window placement, number of windows, insulation thicknesses, amount of roof overhang, and a variety of other passive design features.

Further, computers can be used to simulate conditions which affect construction through a system called queuing theory. The number of lanes needed for a road, the number of spaces needed in a parking lot, and the number of painters needed to paint buildings can all be determined by using queuing theory and computer simulation.

In addition, the computer can reduce facility costs. The Air Staff should ensure that information on new products which can reduce construction or operating costs is passed to bases for inclusion in the civil engineering data base. Individuals from the Air Staff should visit construction trade shows to evaluate new construction materials and their possible application for military use. Materials which show promise should be formally evaluated and recommended to the MAJCOMs for use in upcoming designs.

The reuse of complete facility drawings and specifications as "standard designs" can also reduce cost and manpower requirements while improving facility quality. For example, the same interior design could be used for all dining halls of a similar size. The exterior facades of facilities could be changed to harmonize with the local base architecture. In any case, significant dollar and time savings would be realized with the reuse of successful drawings and specifications.

As a minimum, criteria or policy should be more clearly established to reduce what the Packard Report refers to as "gold plating." In simple terms, gold plating is buying more or better than what is needed. In facility acquisition, gold plating is easy to identify but hard to eliminate. Part of the reason is pressure at base level to be, or at least look, the best. The only possible buffer between the designer and the user is the MAJCOM. This is another instance where the MAJCOM must stand up to its responsibility and eliminate gold plating during the design criteria and review process.

Such questions as how many offices a TAC fighter squadron facility requires should not be left to the judgment of a user who has never been involved in developing a facility requirement before or to a commander who may want to leave a personal memorial. Criteria should be established by the MAJCOM for its unique facilities and by the Air Staff for facilities common to all commands.

### **Using Commercial Products**

Another good Packard Commission recommendation is to expand the use of commercial products. Commercial specifications should be used in the design and construction of all facilities whenever possible. The Packard Commission maintains that "DOD cannot duplicate the economies of scale possible in products serving a mass market, nor the power of the free market system to select and perpetuate the most innovative and efficient producers." It might be different if

military specifications resulted in a higher quality product or a cheaper cost to the government. More often than not, this is not the case. An engineer in the Air Force would be hard-pressed to convince a housewife living in military housing that the paint bought to meet military specifications is better than the paint available at any hardware store—especially since she cannot wash dirty fingerprints from her living room wall without removing the paint.

The "quality" military specifications strive to obtain for paint can just as easily be obtained by letting contractors choose paint from a top three, "best price" list. Choosing the three manufacturers to be listed would depend on the past performance of their paints. Paint performance could also be a part of the base civil engineering computer system data base.

### Increasing Competition

The increased use of competition is another proven method to reduce cost supported by the Packard Commission. One of the most important ways to increase competition in facility acquisition has already been discussed—use commercial specifications. There are other ways to increase competition which have been known for some time. In 1976, the Air Force commissioned two architectural-engineering firms to determine why military housing cost more than civilian housing, even though military housing was usually built in larger quantities. Both firms reported many contractors did not want to get involved with the complicated military construction process, voluminous specifications, and the unreasonable number of inspections.

***"By 'prequalifying' bidders or using a selection system other than just cost, many unscrupulous bidders would be eliminated and past good performance by a contractor could be rewarded with future facility contracts. A result would be more reputable contractors bidding on military projects."***

The Packard Commission recommended that "Federal law and DOD regulations provide for substantially increased use of commercial-style competition, emphasizing quality and established performance as well as price . . . (to determine a contract winner)." This is an excellent suggestion which the 1976 housing study also supports. The study found that many contractors were deterred from bidding because unqualified bidders would bid low on projects and then hope to earn their profits through cost changes. By "prequalifying" bidders or using a selection system other than just cost, many unscrupulous bidders would be eliminated and past good performance by a contractor could be rewarded with future facility contracts. A result would be more reputable contractors bidding on military projects. The computer systems of the construction agents could be used to keep construction performance statistics on contractors in a region or the entire United States.

### Improving Quality of Acquisition Personnel

The final recommendation to improve the execution phase of facility acquisition construction is to improve the quality of

acquisition personnel. This recommendation is also one encouraged by the Packard Commission and, as General Welch said, execution has a much greater impact on productivity than does quality of management decisions. In other words, people make the difference. Their training, their experience, and their motivation make a decision or a system work. The Packard Commission made the point that the people who execute acquisition programs are undertrained, underpaid, and inexperienced compared to their counterparts in industry. Although these comments were directed at weapon systems acquisition, the same is true for those involved in facility acquisition. This includes the engineers who program the projects and participate in the design at base, MAJCOM, and Air Staff levels as well as the design, contracting, and construction engineers at the Corps of Engineering and Naval Facilities Command.

The chance of obtaining any significant pay increase for such a large number of people is remote and really not a viable solution. To compensate for lower pay, a concerted effort must be made to provide other incentives. Incentives, such as additional training, a pleasant workplace with all the tools needed to do the jobs (such as computers), recognition and job satisfaction, and the appropriate administrative staff, would help make up for lower pay.

### Reform is a Necessity!

There are a variety of reasons why the facility acquisition process must be reformed. The reduction of officers in the military and the impact of the Gramm-Rudman-Hollings Act will reduce the number of managers and funding available while increasing the need to manage. The rising cost of operational and direct mission support facilities will reduce the funds available to meet the higher expectations of the military population for better working and living conditions. Finally, two of the most compelling reasons for facility acquisition reform are the obligation of the military to spend taxpayers' money as efficiently and effectively as possible and, at the same time, provide for the national defense. Each of the participants in the acquisition process from user to Congress and from contracting office to contractor can contribute to shorter acquisition cycles and less expensive and better constructed facilities.

The facility acquisition system will not be improved by more rules and restrictions. Only better management systems leading to more productivity will provide the solution. Just as we need more "bang for the buck" in weapon systems acquisition, we must have "more bricks for the buck" in facility acquisition. This can be done by taking the responsibility for bricklaying back from the bean counters and returning it to the masons.

#### References

1. Report to the President on Defense Acquisition by the President's Blue Ribbon Commission on Defense Management, *A Formula for Action*, April 1986.
2. Welch, General Larry D. "Management and Productivity," *Program Manager* (September-October 1985), pp. 43-45.
3. Young, Sharon B. "Set 'People' Priorities, Congressman Tells DoD," *Air Force Times*, 23 March 1987, p. 42.
4. Peters, Thomas J. and Waterman, Robert H., *In Search of Excellence* (New York: Harper and Row, Publishers, Inc, 1982), p. 3.

**AJL**

# Meeting USAF Civil Engineering Customer Expectations

Captain Max E. Kirschbaum, USAF  
Student, Graduate Engineering Management Program  
Air Force Institute of Technology  
Wright-Patterson AFB, Ohio 45433-6583

***"No other base organization directly affects the living environment of every person on a base as does the BCE organization."***

The Base Civil Engineer's (BCE) primary mission is to prepare the necessary assets and develop skills to sustain a global warfighting capability. While the warfighting mission must receive highest priority, the BCE is also responsible for the construction, maintenance, and repair of all base facilities to support the mission during peacetime. Air Force Regulation 85-1, *Resources and Work Force Management*, states, "No other base organization directly affects the living environment of every person on a base as does the BCE organization."<sup>1</sup> As a support organization with a community-wide impact, BCE must be committed to satisfying its customers while meeting all mission requirements. Moreover, Major General George E. Ellis, Director of Engineering and Services, Headquarters USAF, emphasized a "focus on customer service" as one of four guiding principles.<sup>2</sup>

## The Problem and Solution

The BCE usually is evaluated on its resource efficiency, schedule compliance, productive hours recorded, and other easily quantifiable measurements. Customer satisfaction is the missing component, primarily because it is difficult to measure, and because it is believed to be embodied in all the measurable quantities.

Understanding customer perceptions is fundamental to satisfying customers. USAF Civil Engineering customers were the focus of a study to determine what factors were the most important when dealing with the BCE organization. The study included facility managers, who have routine contact with BCE, and field grade officers, who are potentially in command positions. Nine hundred seventy-six randomly selected building managers and field grade officers at 82 active USAF installations responded to the customer satisfaction survey. A survey was used to study customers' perceptions because it was the most practical and economical way to reach a widely dispersed sample of the population in a short period of time. Survey questions formed the basis of the customer satisfaction model shown in Figure 1. The customer satisfaction model was developed from current service literature and previous research by Captain Singel in Tactical Air Command.

The model was also mathematically refined, and only statistically significant model factors and components were retained. The component relationships were confirmed using factor analysis, and a correlation matrix showed moderate positive correlations between the four model factors.

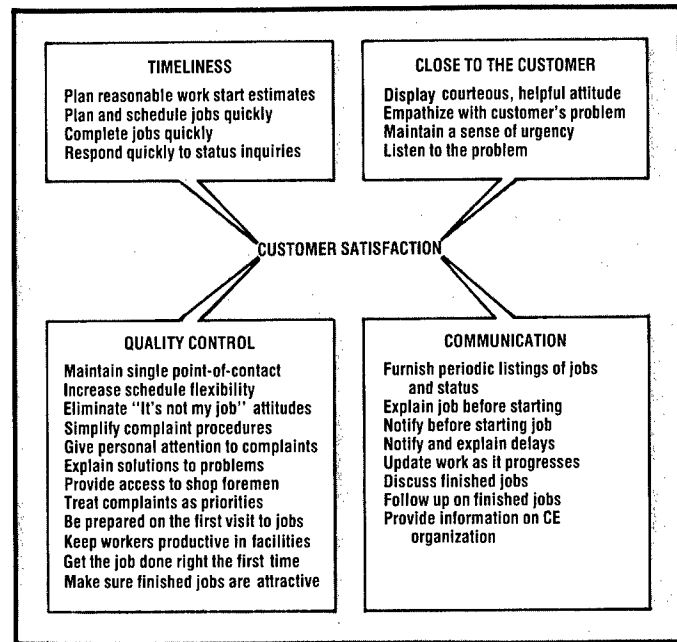

Figure 1: USAF Civil Engineering Customer Satisfaction Model.

## Results

USAF Civil Engineering customers uniformly agreed on the importance of each model factor. Table 1 shows the relative importance of each model factor. The importance ratings were determined based on the mean scores for each model factor, given in parentheses. The mean scores are based on a five-point Likert scale, where a value of one indicated the survey item had no importance to the respondent, and a value of five indicated the survey item had extreme importance to the respondent. There is perfect agreement between all three subgroups. Because each model factor is made up of several components from the survey, the ratings must be interpreted somewhat cautiously. For example, "close to the customer" was rated third in importance among the four model factors; but one of its components, "display a courteous, helpful attitude," was rated very high by all subgroups. This does not diminish the value of Table 1; it just serves as a reminder that each model factor is actually composed of several components, each assigned a different degree of importance by the respondents.

### Timeliness

Timeliness is first and foremost to BCE customers. Customers expect minor job orders to be completed quickly,

MODEL FACTOR IMPORTANCE RATING				
Variable	Aggregate	Military Building Manager	Civilian Building Manager	Field Grade Officer
Timeliness	1 (4.069)	1 (4.027)	1 (4.124)	1 (4.113)
Quality Control	2 (3.905)	2 (3.885)	2 (4.018)	2 (3.843)
Close to Customer	3 (3.825)	3 (3.825)	3 (3.913)	3 (3.774)
Communication	4 (3.581)	4 (3.581)	4 (3.687)	4 (3.458)

Table 1.

and they expect to be given reasonable start dates for larger jobs. Interestingly, the BCE already has concrete measures for timeliness. Jobs orders, the greatest volume of the BCE's workload, presently have prescribed time limits for completion. The BCE can satisfy basic customer expectations by emphasizing the importance of completing job orders on time, or, better yet, ahead of schedule.

### Quality Control

Customers subjectively evaluate the BCE's organizational structure, response to complaints, and quality of workmanship. Customers are key players to service organizations; therefore, BCE should design a flexible, simple service system to meet customer needs. Service management experts Karl Albrecht and Ron Zemke state that "one of the most common symptoms of mediocrity in service is when the customer finds it necessary to run through an organizational maze to get his or her needs met."<sup>3</sup> BCE customers prefer a single, responsible point of contact for all communications and problems. Also, customers do not want to hear craftsmen say, "It's not my job," or "You have to call someone else." Instead, they want to see craftsmen who either finish the job or get the necessary help to finish the job.

***"The BCE can satisfy basic customer expectations by emphasizing the importance of completing job orders on time, or, better yet, ahead of schedule."***

BCE customers consider fast, personal response to complaints an important indicator of service. In his discussion on customer service, General Ellis states, "Make it easy for customers to complain—listen and respond."<sup>4</sup> In the late 1970s, a White House-commissioned study on consumer complaint behavior found that 96% of dissatisfied customers never complained because they perceived that companies did not satisfactorily respond to complaints—it was useless.<sup>5</sup> The message is clear for the BCE—establish simple complaint procedures and provide fast, personal service to customers with complaints.

There is no substitute for quality of workmanship. The issue is what does the customer perceive. The BCE people are often called the "look and leave gang." Customers see engineers, planners, and foremen make repeated trips to examine job sites, but it seems no one shows up to do the work. While job

site investigations may be fully justified, customers may form negative perceptions based on what seems like a lot of unnecessary delays. Also, while customers may not be able to evaluate the technical competence of the BCE craftsmen, they can easily judge whether craftsmen are prepared on the first visit, whether they get the job done right the first time, and whether the craftsmen are all busy in the facility. These are the elements of the customer's perception of the quality of BCE work. Fortunately, these perceptions of quality can be controlled. First, BCE representatives should contact the facility manager before making a job site visit. Not only will the facility manager understand the purpose of the visit, but he or she will also see that progress is being made to complete the work request. Second, pride in workmanship should be emphasized from the top down. Craftsmen who take pride in their trade are more likely to be prepared to complete the job right—the first time.

### Close to the Customer

The personal attributes of BCE service people impact customer satisfaction. Management consultant Thomas Peters often talks about successful companies that "smell" of customers; that is, they put the customer first, and the customer is the obsessive focus of all involved.<sup>6</sup> The importance of the customer-Customer Service Unit (CSU) encounter cannot be overstated. Primary service people such as CSU technicians should possess quality interpersonal skills. It seems obvious that customers prefer to be served by courteous, helpful people. Just as important, CSU technicians should be knowledgeable of the BCE's abilities and limitations, and should be able to provide simple, authoritative answers.

### Communication

The elements of the "communication" model factor indicate that BCE customers want to be involved in their work requests from start to finish. Although "communication" was the lowest-rated model factor, its scores were all above the Likert scale median value of three. The most repeated comment in the survey was that customers want to be given periodic listings showing the status of all jobs. Open, frequent communication can be mutually beneficial to the BCE. Navy Commander John F. Conroy, a facilities engineer, points out that customers of engineering projects are less likely to become frustrated by slow progress and delays if they are constantly informed of problems and what is being done to solve them.<sup>7</sup>

### Summary

Customer perceptions and satisfaction should be important to a service organization such as USAF Civil Engineering. In order to make customer satisfaction a useful performance indicator, BCE officers need a reliable method to quantify and evaluate it. This study provides the basis for developing such a measurement.

Familiarity with the components of the modified customer satisfaction model can help BCE officers better understand and serve their customers. First, this study confirmed the preeminence of timeliness and quality. BCE officers should recognize that customers place the greatest importance on

*Continued to 33* ▶

## Can We Win the War With What's on our Flight Line?

**Captain Gary L. Gemas, USAF**  
*Directorate of Maintenance*  
*Air Force Logistics Management Center*  
*Gunter AFS, Alabama 36114-6693*

In recent years USAF strategy has been to win a war from a position of technological superiority, i.e., our technologically superior aircraft will inflict losses on enemy forces at a rate high enough to overcome their numerical advantage. To ensure success, we have calculated the number of aircraft, their required capabilities, number of pilots, required training, and logistics support needed. We put all the variables together into possible scenarios and determine what the operational readiness (OR) rates or full mission capable (FMC) rates must be in the various commands to consider ourselves ready for war. But can we really depend on our "technological advantage"? What if some of the methods we must use (or don't use) to evaluate potential for success or failure are faulty?

Tactical forces continue to be plagued by inadequate maintenance troubleshooting. To improve troubleshooting the fault reporting and fault isolation (FR/FI) concept applies engineering logic to structure the maintenance debriefing and troubleshooting process. FR focuses on collecting information (pilot observations, built-in-test (BIT), etc.) using diagnostic logic trees that follow the functional operation of the aircraft system. The FR logic tree produces a fault code which defines a specific malfunction. This fault code is provided to the maintenance technician to locate the corresponding fault isolation logic tree in the FI manual. The FI logic tree guides the technician through a troubleshooting process based on the functional operation of the system and reliability and maintainability information. This provides the framework for effective diagnostics, troubleshooting, and repair of malfunctions as well as reducing, and possibly eliminating, false troubleshooting actions.

In 1983, HQ TAC/LG asked the Air Force Logistics Management Center (AFLMC) to determine why FR/FI manuals were not being used to identify and troubleshoot aircraft malfunctions. During the resulting AFLMC study at three F-15 and F-16 bases, we observed that in fact the manuals were not being used properly and started an analysis using sample data. We concluded that, primarily because of human error, there was only a 25% chance that fault codes developed in the aircrew/maintenance debriefing would lead to a valid maintenance corrective action (1:4).

Is the FR/FI concept flawed? If used correctly, would we develop more precise discrepancy reporting? Could we provide better feedback to the design engineers? To answer these questions, AFLMC evaluated a computerized fault reporting program designed to ensure structured compliance with fault logic (2:13). At the bases where this program was tested, there was a 200% to 400% increase in reported discrepancies. What does this say about the overall accuracy of our status reporting if we are under reporting discrepancies to this extent?

Engineers have developed technical orders for both aircrews and maintainers into a closely coordinated set. The operators

manual (-1) describes how the aircraft works functionally. Functions described in the -1 are reformatted into logic trees in the fault reporting manual (FRM) which is used to debrief aircraft malfunctions. At the conclusion of the logic tree, a fault code is developed to communicate a specific functional failure to maintenance. Maintenance then uses the fault code for cross reference into a fault isolation manual (FIM) where another logic tree is used to isolate the cause of the failure. Once the problem is isolated, the FIM identifies job guides and other reference material required to repair the aircraft. When a problem is identified that is not covered by FRM/FIM or there are errors in the logic trees, an AFTO Form 22, Technical Order System Publication Improvement Report and Reply, should be submitted to correct the tech data. Logically, this process should work if initiated and administered properly. This type of manual fault reporting/debriefing process is described in Figure 1.

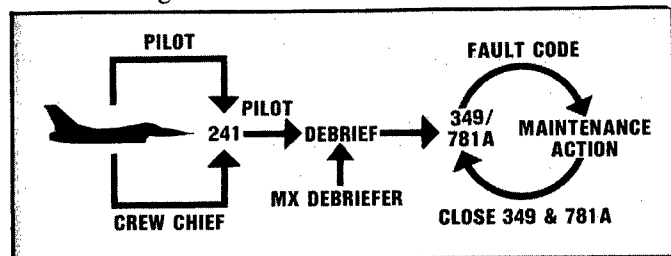

Figure 1.

### The Problem in Its Simplest Form

Our first concern then as logisticians is to answer the question: When is the aircraft broken?

- A. When the pilot says its broken?
- B. When maintenance says its broken?
- C. When built-in-test (BIT) says its broken?
- D. All of the above.

Obviously, if the pilot or maintainer finds fault with the operation of the aircraft, it is broken and must be repaired. But in our modern sophisticated aircraft, pilots and maintenance personnel only see about 35% of system failures. The remaining 65% are reported by BIT and may degrade aircraft capability but have no effect on the last mission. Therefore, the answer to the question is D. A popular notion about BIT is that it is predictive in nature—forecasting some future time when the system will fail. In fact, BIT is telling us that something has failed and the system is operating outside normal parameters—operating on a redundant function which may or may not limit capability—or has totally lost a capability. Therefore, the aircraft is broken even if the pilot has not observed a malfunction affecting the mission. In fact, in war, if he sees a visible failure, it may well prove fatal.

Arguments against the BIT system concept continue to point to lack of understanding. For example, BIT accuracy has been questioned; but if BIT information is properly reported in debriefing and accurately coordinated with pilot observations, the system generally works very well. Further, if we are to find those BITs that are "bad," we must gather the feedback data required to support product improvement. To date, there are no across-the-board BIT validations for an entire weapon system. The data required to accomplish such a validation either does not exist or is incomplete because of failure to use FRM/FIM and the associated processes. What data we do have is incomplete and BIT goes unreported, leaving bad information with which maintenance must work. As a result, maintenance targets the wrong problems, makes false removals that result in large numbers of cannot duplicate (CND) and retest OK (RTOK), and otherwise wastes logistics resources.

### What Needs to be Done?

It is fine to say all this, but what shall we do? In the short run (12-15 months), we must first recognize that engineers have integrated aircraft operations with the tech data that supports them. Failure to grasp this results in weapon systems that do not meet their full design capability. Their associated tech data has failed to mature because feedback to improve the data is nearly nonexistent. Second, we must get back to basics and implement the BIT system as it was intended—identification of an existing malfunction. Third, we need to recognize and correct problems associated with proper BIT implementation. For example, the process starts with debriefing. If the system is to work, we must receive a good debriefing that completely and accurately represents the malfunction. We must completely document all the information going into maintenance production as well as the maintenance action required. Deviations from tech data must be reported, reviewed, analyzed, and action taken to correct shortcomings; i.e., submit AFTO Form 22.

In the long run (FY89 and beyond), we must look at other methods to simplify the process, including debriefing and incorporation of feedback. For example, Aeronautical Systems Division/TAFI has developed computerized fault reporting (CFR) for the F-15 weapon system. Adaptable to any weapon system using FRM/FIM, this system automates the debriefing process. Further, it provides the capability to input debriefed information into the core automated maintenance system (CAMS) and in conjunction with this system can provide an automated feedback capability to identify potential areas for improvement.

CFR embeds the logic and function of a paper technical manual into a microcomputer program that is easy to use and thus encourages use. The overall scheme of the program is to have the pilot operate the microcomputer to provide first-hand information on the aircraft malfunction. The CFR process parallels the manual FR process (Figure 2).

The pilot and crew chief continue to fill out the AFTO Form 241 the same way and the pilot brings it to the debriefing. There, the pilot sits down at the microcomputer and inputs the tail number of the aircraft flown. The computer then accounts for the aircraft model/block configuration and time compliance technical order (TCTO) changes; i.e., the aircraft effectivity code. From this point on, the computer will only consider and display information for this particular aircraft. Next, the pilot keys the flight and BIT information into CFR. CFR correlates

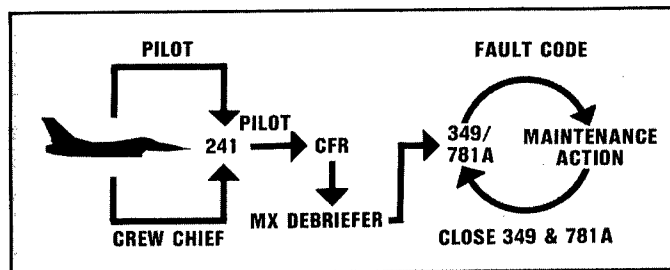

Figure 2.

the information and develops fault codes for BIT reported and inertial navigation system (INS) faults. The pilot then identifies any system/subsystem faults that were not automatically fault coded by CFR. CFR will then generate questions and offer cockpit displays to lead to a complete fault code.

If the pilot observes a fault not covered by CFR, the fault code will be developed as far as the pilot can answer CFR questions. At this point, CFR Xs out the remaining fault code data field and displays a word processor for entering the write-up. Using this information, the write-up can then be worked by maintenance. CFR also provides feedback to update and improve the system.

CFR maintains a historical data base of three flights per aircraft. The purpose of the three-flight history is to provide for INS terminal error tracking, exceedance counter tracking, and repeat and recur identification. Repeat write-ups are defined as identical malfunctions which occur on consecutive flights of an aircraft. A recurring write-up is one where, once repaired, the aircraft operates normally for only one flight before exhibiting the identical write-up. Because CFR has the capability to track repeat and recurring write-ups by fault codes, the failures are identical functional failures rather than the loose interpretation of repeat/recurs currently applied using unstructured narratives. Further, CFR has the capability to easily provide alternate fault codes and logic trees depending on the repeat/recur being reported.

For our study, output of CFR was a modified TAC Form 93 with the required maintenance information. Maintenance debriefers transcribed CFR information to AFTO Forms 349 and pilots completed AFTO Forms 781A as they normally would have. Maintenance then corrected the write-ups and closed out the 349s. In the operable version, CFR will feed automatically into CAMS.

At the outset of the AFLMC study, pilot reaction to CFR was mixed. Some were opposed to operating the microcomputers while some enjoyed using them. However, all pilots were concerned about spending as little time as possible in maintenance debriefings. Many pilots questioned the need to operate the computer personally. They believed the maintenance debriefer should operate the computer and enter the data from the pilot write-ups in the AFTO Form 781A or ask the pilot the questions presented by CFR on the computer monitor. This, however, violates current FR and CFR procedures which are both written in accordance with the 1F-15A-1 aircraft operating manual using the "pilot's language." The purpose of FR is to get firsthand observations of the functional failures and convert them to a fault code with an unambiguous statement of a malfunction that maintenance can correct. Current FR manuals therefore require the pilots to answer the functional questions, unbiased by the maintenance debriefer. Therefore, it is essential that pilots operate the CFR system.

Continued to 17 ►



# CAREER AND PERSONNEL INFORMATION

## The LCCEP Program Is Working: A Success Story

**Lynda Wampler**  
**AFCPMC/DPCMLR**

*Randolph AFB, Texas 78150-5000*

Mr Lloyd K. Mosemann II, presently Deputy Assistant Secretary of the Air Force (Logistics), had a vision in 1974 of establishing a professional civilian logistics work force. He believed that a program could be developed that would seek out high potential civilian logisticians, broaden their perspectives, and help to build a stronger logistics community. He also believed that by moving people between commands or between organizational levels and crossing occupational lines, we could avoid the tendency for "stovepiping" civilian logisticians. Faced with ever-more complex technology and the seemingly endless personnel cuts, he felt there was a definite need for people with a broader understanding of the total logistics concept.

The Logistics Civilian Career Enhancement Program (LCCEP) was born of that vision. Under the direction of Mr Mosemann and Lt General Leo Marquez, many inroads have been made toward achieving the LCCEP goals. Its charter states:

The Logistics Civilian Career Enhancement Program is designed to encourage and manage the development of employees to their fullest potential to meet the logistics needs of the Air Force. In support of this concept, we will endeavor to:

Develop highly skilled professional civilian logisticians to meet current and future mission needs through a central career development process.

Assure the individual selected for a position is the best qualified in terms of specific job requirements and career management needs.

Identify high potential personnel and provide them with managerial and technical experience/training, lateral movement opportunities both geographic and functional, and promotional opportunities leading to high-graded positions.

Encourage participation in Air Force upward mobility programs.

Encourage personnel in intermediate level positions to broaden their experience and prepare themselves for participation in the logistics executive force inventory and the logistics executive Cadre.

Promote the achievement of Equal Employment Opportunity and handicapped employee goals.

Ensure all actions are based upon merit without discrimination due to race, color, religion, sex, national origin, age, marital status, physical handicap, political affiliation, labor organization affiliation, or non-affiliation, or any other non-merit factor.

LCCEP provides both a challenge and an opportunity to the individual logistician Air Force wide to compete for reassignment or promotions to GS-12 through GM-15 program positions. The challenge is to plan and pursue realistic career goals which may be achieved through planned developmental activities, while at the same time enhancing job performance. Although there are many who have used the LCCEP avenues for career development, the following are just four examples of success stories from among our logistics executive Cadre members:

**Andrew E. Figueroa**  
**HQ AFLC/DST**  
**Wright-Patterson AFB Ohio 45433-5000**

Recently promoted to an LCCEP position as Chief, Transportation Management Division, HQ AFLC, "Andy" Figueroa was one of the earliest Cadre members. He is a classic example of a high potential logistician who was willing to make personal sacrifices to climb the ladder of success and to make full use of the LCCEP.

As one of the initial registrants in LCCEP, he was selected for the executive Cadre as a GS-11 while a transportation officer at Sheppard AFB, Texas. He was selected through LCCEP for long-term, full-time training in which he attended Midwestern State University for nine months to pursue graduate study in logistics management training. In June 1981 he was promoted to an LCCEP position as Chief, Traffic Branch, San Antonio Air Logistics Center. From there, he again made a geographical move to the Directorate of Transportation, Wright-Patterson AFB. In 1983 he completed his thesis and was awarded an MBA.

Andy's advice to logisticians everywhere is: "Take a good hard look at yourselves; evaluate your career goals; find out what it takes in the way of education, development, and training to reach those goals; and set your course in that direction. Use the LCCEP to help attain those goals. The essential thing to understand is that you must take the initiative—you must take the responsibility for your career. LCCEP is there for you; find a way to make it work."

**Dale Sampson**  
**HQ USAF/LEXM**  
**Washington DC 20330-5000**

Accepting a GM-14 LCCEP career-broadening assignment at HQ USAF in the Aircraft Modification Division as a Logistics Management Specialist is just the latest in a series of events Dale Sampson has experienced in climbing his own particular ladder of success. Dale was selected for induction into the first LCCEP executive Cadre. A dedicated, energetic individual, he has spent the last few years preparing himself to become a senior logistician.

Following a tour of duty with the military side of the Air Force where he achieved the rank of Captain, Dale entered Civil Service as a Logistics Management Specialist, GS-11, Homestead AFB, Florida, in 1977. Two years later, he was promoted to Transportation Management Specialist, GS-12, Air Force Logistics Management Center (AFLMC), Gunter AFS, Alabama. While there, he completed work on, and was awarded, an MA Degree in Human Resource Management from Pepperdine University as well as attending the Air Command and Staff College at Maxwell AFB. His next promotion came about through the LCCEP at the Oklahoma City Air Logistics Center where he was selected as Chief, Aerial Port of Embarkation (APOE) Branch, Directorate of Distribution.

Dale believes strongly in making use of the LCCEP. He feels it is an excellent career-balancing program which offers many avenues for development. He advises participants in the program: "Recognize opportunity knocking. LCCEP is not a one-sided proposition; participants must be flexible and mobile in order to maximize the opportunities offered."

**Dennis R. Dillinger**  
**HQ AFCMD/PD**  
**Kirtland AFB, New Mexico 87117-5000**

Dennis Dillinger, GM-2130-14, is Air Force Contract Management Division's Chief of Transportation, Packaging and Manufacturing Support. He has 26 years of progressive, dedicated career experience which is the epitome of a broadened logistician. Through carefully chosen career paths and the advantages afforded by the LCCEP, Dennis has developed into the type of "Generalist Loggie" sought by the Air Force.

Since Dennis registered in LCCEP at the GS-12 level in 1982, he was selected into the Air Force Logistics Executive Cadre in February 1984; competed successfully for a temporary GM-346-13 LCCEP career-broadening assignment in Logistics Plans at HQ SAC in August 1984; was promoted to GM-2130-13 at Kirtland AFB in August 1985; was nominated and selected for LCCEP long-term, full-time undergraduate training in July 1986; and was upgraded to GM-2130-14 in December 86.

He has consistently been a self-motivated high performer and achiever, boasting 56 performance and incentive awards since entering Civil Service in August 1964 at the WG-5 level. His experience acumen includes outstanding performance in managing seven of the logistics elements (Acquisition/Logistics/Systems Management, Vehicle Management, Transportation Management, Packaging Program Management, Industrial Production Management, Maintenance Management, and Supply and Distribution Management). Over the course of his career, he and his family have relocated eight times. Dennis credits mobility, hard work, self-development, and LCCEP for his career successes. His advice to others is threefold:

- (1) Put forth the extra time, effort, and follow-through necessary for a complete, well-done job. That makes the easy distinction between just doing a job and a job done well.
- (2) Register in the career program for which you are eligible and maintain a current, comprehensive career brief.
- (3) Make sacrifices for the self-development, education, skills broadening, and mobility needed to make you a desirable and competitive promotion candidate.

**Diann Lawson**  
**SM-ALC/MMC**  
**McClellan AFB, California 95652**

Diann Lawson, as Deputy Chief of the Communications, Electronics and Space Management Division, McClellan AFB (an LCCEP position), is responsible for approximately 24 systems/networks, 64,000 items, 100 modifications, and 145 acquisition programs. Beginning her Air Force career as an FSEE trainee at Wright-Patterson AFB, Diann has continued to pursue her own personal "search for excellence." She earned a BS in Mathematics from Wright State University in 1974 and an MS from AFIT in 1978, where she was a Distinguished Graduate. In 1979 she received certification as a professional logistician and in 1980 was an "Outstanding Young Woman of America."

True to the concept of the LCCEP, Diann has overcome the traditional "stovepiped" logistician image. LCCEP has afforded her opportunities to cross occupational lines and move across the country. She has served as an Operations Research Analyst, an Inventory Management Specialist, and a Logistics Management Specialist. In addition, she has worked at the HQ AFLC level and moved to an Air Logistics Center using LCCEP channels. This diverse experience, coupled with her education and training, has prepared Diann to assume ever more responsible rolls in today's Air Force.

"Searching for excellence" is a full-time job. Diann's advice for those seeking excellence is: "Make every task a learning experience; learn the why, not just the what; be responsive and honest (credibility is your most important attribute); recommend solutions rather than requesting answers; and be professional." She urges that you be aware of LCCEP opportunities and take the initiative to apply for them.

These logisticians are examples of just a few of those who have recognized the value of the LCCEP and made it work for them. Not only have they succeeded in their own careers, but they have provided an invaluable service to the Air Force. LCCEP has been instrumental in contributing to the success of these valuable civilian logisticians. It finds the best people and helps to structure and facilitate their career progression. The LCCEP provided these people a tool and an avenue to aid in advancing their careers more rapidly. They took the initiative and made LCCEP work for them. You can do it, too.

## *Civilian Career Management*

### **Statistics Speak for LCCEP**

The Logistics Civilian Career Enhancement Program (LCCEP) strives to encourage the personal and professional development of the logistics work force to its fullest potential to meet Air Force needs. A review of relevant statistical indicators illustrates the importance of participation in the program.

Since there is no mandatory conscription into the LCCEP, initial program registration is the responsibility of the individual. AF Pamphlet 40-3, *A Career Program for Logisticians*, and AFR 40-110, Vol IV, *Logistics Civilian Career Enhancement Program (LCCEP)*, are must reading for the prospective registrant before applying for LCCEP through the local Central Civilian Personnel Office (CCPO). Once a registrant has selected the desired locations and lowest acceptable grades of consideration on AF Form 2675, Civilian Career Program Registration and Geographic Availability, the CCPO will assure the registrant's eligibility using established criteria and enter registration and geographic availability data into the Personnel Data System-Civilian (PDS-C). This data is then sent to the LCCEP office at the Air Force Civilian Personnel Management Center, Randolph AFB, Texas. Competition is keen within the LCCEP as over 13,300 active registrants are already in the system, representing virtually every command and location in the Air Force.

So why bother to register with those apparent long odds confronting you? Because of the benefits not otherwise available to the non-registrant (person not considered for vacant positions managed by the LCCEP). First, the LCCEP manages and provides certificates for over 2,200 civilian logistics positions in the Air Force. That number equates to approximately 34% of all logistics positions in grades GS-12 through GS/M-15. Additionally, LCCEP bears the permanent change of station (PCS) costs associated with career program moves and provides an optional relocation service for all selections at the GS-12 level and above. A breakdown of FY86 selections is shown in Figure 1.

LCCEP registrants are also eligible for many educational and professional enhancement programs that assist in filling gaps in education and experience. Participation in these programs has, in many instances, resulted in positive career growth through subsequent promotions or broadening assignments. The number of training and educational opportunities available to LCCEP registrants is extensive and is expanding each year.

Next, registrants may elect to compete for the LCCEP Executive Cadre. Cadre membership is both highly competitive and highly prestigious (presently at 971, or approximately 7% of all registrants). There are clearly defined advantages associated with Cadre membership. During FY86, Cadre members received 30% of all

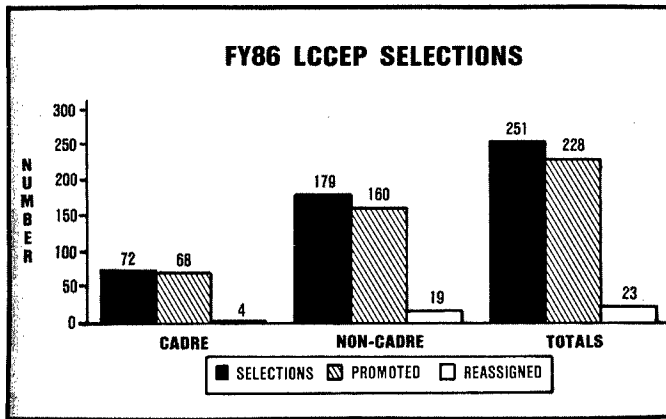

Figure 1.

promotions provided by LCCEP certificates. This is very significant when considering the small proportional numbers of Cadre members. Most importantly, that positive selection trend has continued through FY87. Cadre members are highlighted on each LCCEP certificate as an informational aid to interviewers.

Another significant benefit for Cadre members is the priority consideration they receive for developmental opportunities. While over 70% of the current Cadre have a bachelor's degree or higher, they, along with the 30% with no degrees, have a distinct opportunity to participate in one of several available graduate or undergraduate programs at either military or civilian institutions. LCCEP pays for costs associated with these courses. Cadre members will be offered a one-day seminar during FY88.

Further, Cadre applicants who are selected for personal interviews receive a Cadre Interview Score (CIS). The CIS has become increasingly significant since its adoption as a tiebreaker on LCCEP certificates. During the first half of FY87, this meant promotions for five Cadre members who would have not otherwise appeared on the certificate without CIS consideration. Other Cadre perks include receiving the quarterly *Air Force Journal of Logistics* and the semiannual LCCEP Cadre Notes. Members are also eligible to serve on the LCCEP Palace Team at Randolph which is in itself a challenging and rewarding experience.

It has been said that logistics is not a spectator sport, and that is most certainly true with LCCEP. Civilians may elect to sit on the sidelines and watch others succeed, or elect to compete head-to-head. LCCEP provides registrants with access to the opportunities which directly impact their future direction and growth. Although there are no implied guarantees of success with LCCEP, the program provides a distinctive challenge—the rest is up to the individual.

(Source: Steve Doneghy/AFCPMC/DPCML, AUTOVON 487-2498)

## Military Career Management

### Air Force LCBP Professional Development

If you are a highly motivated and aggressive captain or major with a logistics background (AFSC 31XX, 40XX, 60XX, 64XX, and 66XX) who wants to become a future leader, then the Air Force Logistics Career Broadening Program (LCBP) is for you! This program provides officers an opportunity to diversify their experience and improve their potential to fill future senior key logistics positions. Entry into the program is voluntary, with final selection based on individual records of performance.

Once selected for the program, officers are placed on a three-year controlled tour at one of the air logistics centers (ALCs) where they rotate through the Distribution, Contract/Manufacturing, Maintenance, and Materiel Management Directorates. Participants spend six months in each of the four Directorates to gain an overall understanding of wholesale logistics. They are then assigned to a highly visible position within the ALC to spend the last year in direct support of the logistics mission. Here, individuals strengthen their abilities to analyze major logistics problems and formulate sound plans. At the end of the program, the Air Force Military Personnel Center (AFMPC) assigns a special experience identifier to track these officers to spread their specialized talents throughout the Air Force and to fill future priority wholesale logistics positions.

More information on this program can be found by reviewing AFR 400-30, *AFLC Career Broadening Program*. Officers interested in pursuing this challenging and rewarding professional development option can submit an Air Force Form 90 to HQ AFMPC or contact their respective assignments officer at the Center.

(Source: Lt Col Robert J. Pirrie, AFMPC/DPMSL, AUTOVON 487-4553)

▶ Continued from 28

reasonable work start dates, quick response to job status inquiries, and expeditiously planned and scheduled work. BCE officers should also recognize that customers value more than just a commitment to quality; they also value a commitment to correcting situations that do not meet standards for quality. The BCE organization must continue to improve on these more obvious factors that influence customers' perceptions.

people. BCE officers can influence customer perceptions by properly staffing key contact positions in the Customer Service Unit. Although "communication" was not rated as high as the other three model factors, respondents indicated that constant, open dialogue was important. Customers want to be involved and updated on the progress of jobs as they flow through BCE. General Ellis contends that customer service "must pervade every aspect of the Engineering and Services community. If we don't satisfy our customers, we are not doing our job."<sup>8</sup>

**"The message is clear for the BCE—establish simple complaint procedures and provide fast, personal service to customers with complaints."**

Second, BCE organizations should focus improvements on the factors that directly impact the service encounter. Components of the "close to the customer" model factor center around the interpersonal skills of primary service

#### Notes

<sup>1</sup>U.S. Department of the Air Force, Air Force Regulation 85-1, *Resources and Work Force Management* (Washington: Government Printing Office, 21 May 1982), p. 9.

<sup>2</sup>USAF Engineering and Services, *Excellence*, undated, p. 6.

<sup>3</sup>Albrecht, Karl and Ron Zemke. *Service America!* (Homewood IL: Dow Jones-Irwin, 1985), p. 44.

<sup>4</sup>USAF Engineering and Services, *Excellence*, p. 6.

<sup>5</sup>Albrecht and Zemke, *Service America!*, p. 6.

<sup>6</sup>Austin, Nancy and Thomas J. Peters, *A Passion for Excellence* (New York: Warner Books, 1985), p. 45.

<sup>7</sup>Conroy, Cdr John F. "The Customer Expects Too Much," *The Navy Civil Engineer*, Spring 1986, p. 7.

<sup>8</sup>USAF Engineering and Services, *Excellence*, p. 6.

(Capt Kirschbaum is presently assigned to 40 CEF, APO NY 09293.)

AFS

# An Expected-Value-Based Logistics Capability Assessment Model (ELCAM)

Major Roy E. Rice, USAF  
Chief, Operations Research Branch  
Directorate of Logistics Analysis  
Air Force Logistics Management Center  
Gunter AFS, Alabama 36114-6693

Studies conducted to improve base-level logistics in the Air Force are traditionally directed at the specific functional areas of maintenance, supply, transportation, contracting, and logistics plans. In the past, efforts to integrate these areas into an assessment of overall logistics capabilities have resulted in large computer models such as the Logistics Composite Model (LCOM), Theater Simulation of Airbase Resources (TSAR)/TSARINA, and Dyna-METRIC. Several other smaller computer models have been developed by Air Force analysts and civilian contractors. All these techniques have unique advantages and disadvantages. Our efforts in developing ELCAM were not directed at replacing any of these methodologies but rather to serve as an adjunct to the group of techniques and algorithms currently available for assessing logistics capability.

## Clientele

Logistics analysts and the decision makers for whom they work must be able to determine the impact of tradeoffs in the various logistics functional areas. Logistics managers must have the tools to evaluate logistics decisions in operational terms. Toward that end, managers find no universal translation of logistics capability to operational capability. They are forced to wrestle with such terms as operational readiness, fully mission capable, operational availability, weapon system reliability, mission completion success probability, operational effectiveness, and operational suitability. In other words, with regard to criteria or measures-of-merit, what constitutes acceptable or unacceptable logistics capabilities? It is generally believed that sortie generation comes closest to measuring capabilities.

The existing set of assessment models attempts to determine logistics capabilities in some or all these terms. However, most are not explicit in what they are attempting to measure. The degree of detail to which they can be used to model can only be appreciated by those who have had extensive experience using them. And, most logistics managers have neither the time nor inclination to exercise such powerful modeling techniques.

Frontline logistics managers need an easy-to-use tool with a manageable database and immediate response to determine impacts of specific tradeoffs (sensitivities of the system to changes in logistics parameters) and location of "the long pole in the tent." Toward this end, they need a first-order approximation not intended to be an in-depth logistics analysis.

## Problem Statement

What is ELCAM all about?

**GOAL:** To assess capabilities to support the warfighting

mission of an operational unit logistically.

**OBJECTIVE:** Get aircraft into the air and perform the mission.

**COMMODITY:** Time! . . . the only commodity. It is **CONSTANT** . . . you cannot buy more of it. However, you can trade for it.

**CONSTRAINTS:** Functional areas (maintenance, supply, transportation, etc.). Can they perform their intended functions under applicable restrictions?

**RESTRICTIONS:** Spares

Personnel

Support equipment

Munitions

Petroleum, oil & lubricants (POL)

Environment

With this in mind, let's look at the system. The "real world" operational unit (as well as the "simulated" unit) has 24 hours in a day; no more, no less. During each day, a certain amount of time is spent flying sorties. Upon completion of sorties, appropriate times (both deterministic and stochastically governed) are expended in "down" conditions where unscheduled maintenance, battle damage repair, rearming, refueling, and reconfiguration are performed so aircraft can be returned to an "up" condition. Aircraft are then kicked in the tail section and sent back into the air to fly more sorties. Typical daily activities are depicted in Figure 1.

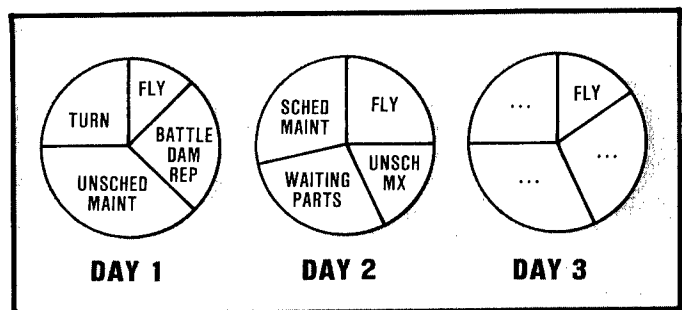

Figure 1: Day-to-Day Operations.

Each day's "pie" is only so big. One slice is taken up by flying missions, another is taken by battle damage repair, and additional slices are taken for other reasons. The goal is to determine whether the pie is big enough and what can be done to stay within the given pie area. Each day there is another pie and more slicing.

Our approach with ELCAM is to view the entire conflict as one big pie. Each slice of the pie is expected to be a certain size—just so big. We want to use these "expected" values to analyze the pie. However, we must also realize that each individual functional area, such as the munitions area, has its

own little pie with which it operates every day. In most cases we only assume that functional area pies are adequate and can perform their jobs.

### The Model (ELCAM)

Once again, the end product of ELCAM is to be viewed as a first-order approximation. Other, more complex models exist to study systems in much more detail. Our intent is to keep things simple.

Aircraft are considered "down" for a limited number of reasons (slices of the pie):

- Unscheduled maintenance
- Battle damage repair
- Scheduled maintenance
- Waiting for parts
- Waiting for resources (support equipment, vehicles, manpower)
- Turning aircraft around
  - Refuel
  - Rearm/reconfigure

More reasons could be modeled but, again, we want to keep it simple.

Using target sortie rates, mission types, sortie length, length of conflict, and number of aircraft assigned, we can calculate the expected size of the slice of the pie for flying. Based on that slice, we can calculate expected values for each of the other slices (discussed later).

With these values calculated, we use a technique documented by Lilijevqvist, Nilsson, and Sjodin to determine aircraft availability.<sup>1</sup>

$$A_o = 1 - u * DT \quad (1)$$

Where

- $A_o$  = aircraft operational availability
- $u$  = average aircraft utilization rate
- $DT$  = mean aircraft downtime in hours/flying hours.

It must be emphasized that determining the expected value for  $DT$  is the key to this entire effort. For, if we can accurately calculate  $DT$ , the theory has proven sound.

Like the ROMUS model (1) of Lilijevqvist, Prob(mission start) $_m$  is calculated using a binomial approach: Prob(mission start) $_m$  is the probability that at least  $k$  out of  $N_a$  (number of aircraft assigned) will be available at an arbitrary point in time for mission type  $m$ .

$$\text{Prob(mission start)}_m = \sum_{i=k}^{N_a} \binom{N_a}{i} A_o^i (1 - A_o)^{N_a - i} \quad (2)$$

Similarly, Prob(fulfill) $_m$ , the probability that, for a mission type  $m$ , exactly  $k$  out of  $N_s$  aircraft starting the mission will successfully accomplish the mission is calculated by

$$\text{Prob(fulfill)}_m = \binom{N_s}{k} D^k (1 - D)^{N_s - k} \quad (3)$$

where

$$D = \exp[-\lambda * \text{ASL}]$$

$$\lambda = (\text{mean-time-between-critical failure})^{-1}$$

$$\text{ASL} = \text{average sortie length.}$$

$D$  is crudely equivalent to mission completion success probability or weapon system reliability. If the user requires more sophisticated calculations of weapon system reliability, such subroutines are not difficult to incorporate in ELCAM.

Once we have calculated these two probabilities (mission start and fulfill), we calculate what Lilijevqvist calls system effectiveness,

$$SE = \sum_m \phi_m * \text{Prob(mission start)}_m * \text{Prob(fulfill)}_m \quad (4)$$

where

$m$  = mission type

$\phi_m$  = relative frequency of mission type  $m$ .

This is precisely the OBJECTIVE in our original problem statement—the probability that the aircraft "get into the air and perform the mission."

Next, we can calculate the individual slices of the pie.

(1) Unscheduled maintenance ( $DT_{UM}$ ). To calculate the expected time spent in unscheduled maintenance, we take the break rate (either by flying hour or by sortie) and average time to repair by mission type and aircraft subsystem.

(2) Battle damage ( $DT_{BD}$ ). To calculate expected time spent in battle damage repair, we take battle damage rate and average time to repair by mission type.

(3) Scheduled maintenance ( $DT_{SM}$ ). We calculate scheduled maintenance similarly to unscheduled maintenance.

(4) Waiting for parts ( $DT_{WP}$ ). We handle waiting for parts in one of two ways. We can allow the user to simply input fill rates and time to get parts by each model part, or we can incorporate percentage of base/depot repair and condemn rates of spares, number of spares, and repair times.

To calculate the latter, we use some of the basics from Dyna-METRIC and make the necessary assumptions allowing us to use Palm's Equation,

$$\lambda_{ss} = \bar{d} * T$$

where  $\lambda_{ss}$  is the (steady-state) expected number in the repair pipeline,  $\bar{d}$  is the average failure rate, and  $T$  is the average repair cycle time. With the assumption that  $d$  has a Poisson probability distribution, then  $\lambda_{ss}$  is the mean of a Poisson distribution and allows us to calculate the probability that there are  $k$  components in the pipeline at any point in time by using

$$P(k \text{ in pipeline}) = \frac{\lambda_{ss}^k e^{-\lambda_{ss}}}{k!} \quad (5)$$

We consider the "spares system" to be an alternating renewal process (2:66-67). The system can be in one of two possible (independent) states:

(1)  $X$  = the state in which the pipeline contains more than the number of spares (which means that all the spares plus one or more parts from the aircraft are in the pipeline, or a part is needed but is not on hand).

(2)  $Y$  = the state in which the pipeline contains no more

than the number of spares (enough parts on hand to satisfy demands).

Obviously, the "spares system" will be in either one of the two states throughout the time of interest. By use of the Key Renewal Theorem (2), the probability of being in each of the states mentioned, in limit, represents the proportion of time spent in each state.

Thus, we can calculate the probability of being in state X using equation (5). And by looking at this as an alternating renewal process, the result is the proportion of time we expect to be waiting for spares. This situation could also be viewed as a Markov Chain, with the states being positive recurrent, aperiodic, or ergodic. The probabilities just calculated are the steady-state probabilities of occupying those states (2:107-114). It must be emphasized that this is *steady-state* and does not account for transient behavior. However, we have constructed many small simulation examples with SLAM (a well-known simulation language) and verified this method gives reasonably accurate results.

(5) Waiting for resources ( $DT_{WR}$ ). This is the most unique aspect of the model. As in Liljeqvist's ROMUS, we use a preemptive, priority modified, multiple channel queuing model to calculate the expected time spent waiting for a resource to become available. "The arriving aircraft are classified in different categories 1, ..., r. An aircraft with higher priority obtains service before one with a lower priority no matter when it arrives to the queue." We define two categories:

- 1 = aircraft demanding unscheduled maintenance
- 2 = aircraft demanding scheduled maintenance

The waiting time for resource type "i" for aircraft priority category "k" is given by

$$W_{ik} = \frac{S_i \cdot \sum_{j=1}^r DR_{ij} (V_{ij} + T_{ij}^2) M_{ir} (S_i - 1)}{2(S_i - M_{ik-1}) (S_i - M_{ik}) \cdot S_i! (1 - M_{ir}/S_i)} \cdot P_{io} \quad (6)$$

where

$$P_{io} = \left[ \sum_{n=0}^{S_i} \frac{M_{ir}^n}{n!} + \frac{M_{ir}^{S_i}}{S_i! (1 - M_{ir}/S_i)} \right]^{-1} \quad (7)$$

$$M_{ir} = \sum_{j=1}^r T_{ij} \cdot DR_{ij} \text{ assume } M_{ir} < 1$$

$$M_{ik} = \sum_{j=1}^k T_{ij} \cdot DR_{ij}$$

$$M_{ik-1} = \sum_{j=1}^{k-1} T_{ij} \cdot DR_{ij}$$

$$W_{ik} = \text{average waiting time for resource type "i" for aircraft priority category "k"}$$

$$M_{io} = 0$$

$$T_{ij} = \text{average service time for aircraft priority category "j" by resource type "i"}$$

$$V_{ij} = \text{variance in service time for aircraft priority category "j" by resource type "i"}$$

$$S_i = \text{number of units of resource type "i"}$$

$$DR_{ij} = \text{demand rate for resource type "i" in connection with maintenance of priority category "j", generated by } N_a \text{ aircraft}$$

$$f_{ij} = \text{demand rate for resource type "i" in connection with maintenance of priority category "j", generated by a single aircraft}$$

$$N_a = \text{number of aircraft assigned}$$

$$r = \text{number of aircraft priority categories.}$$

The resulting expected downtime per flight hour due to shortage of resources, provided that demands on resources occur independently, is

$$\sum_i \sum_k W_{ik} \cdot f_{ik}$$

Now we calculate the expected time spent waiting for resources.

(6) Turning aircraft around ( $DT_T$ ). Take the average time required to rearm or reconfigure an aircraft (pre-sortie tasks) and refuel it (post-sortie tasks) and calculate the expected time spent turning the aircraft.

All these come together in the equation for total expected downtime (T.E.D.):

$$T.E.D. = DT_{UM} + DT_{BD} + DT_{SM} + DT_{WP} + DT_{WR} + DT_T \quad (8)$$

Now, DT in equation (1) is easily calculated. However, we as planners are in serious trouble if T.E.D. + flying hours is bigger than the whole pie.

## Status

The ELCAM model has been written as a prototype in Basic on a Zenith Z-100 and Z-248 microcomputer. It is far from being in its final form. However, some small databases, run with our resident TSAR model, have been converted and also run with ELCAM. ELCAM's results are immediate. Preliminary results are promising (Table 1).

	TSAR	ELCAM
<b>UNCONSTRAINED SPARES, MANPOWER, SUPPORT EQUIPMENT</b>	<b>79.7%</b>	<b>78.5%</b>
<b>CONSTRAINED SUPPORT EQUIP</b>	<b>76.2%</b>	<b>74%</b>

**Table 1: Compare ELCAM vs. TSAR; % Sorties Accomplished (Prob(Start)) Database (6 a/c, 10-day conflict, 1 mission type).**

Besides this "bottom line" or "total pie" figure, we can also obtain expected times in each of the "downing" slices. They also compare quite favorably with TSAR results. A more detailed comparison is in Table 2.

This was an encouraging comparison from the standpoint that ELCAM did not necessarily arrive at the same number for performance measures as did TSAR; but it did highlight the same constraining resources (in same order) and arrived at

		TSAR	ELCAM	
I.	a.	<b>SORTIES FLOWN</b> (2 sorties/day aircraft)	87.8% (83%-92%)	86.5% (80.2%-92.9%)
	b.	<b>RESOURCES MODELED</b>	30	8
	c.	<b>RESOURCE # FOUND TO CAUSE MOST DELAYS</b>	#2,4,7,8	#2,4,7,8
II.	a.	<b>SORTIES FLOWN</b> (2 sorties/day aircraft)	95.8%	94.5% (93.6%-95.4%)
	b.	<b>RESOURCES MODELED</b> (previous levels increased)	30	8
	c.	<b>RESOURCE # FOUND TO CAUSE MOST DELAYS</b>	#4,7	#4,7
	d.	<b>DOWNTIME IN ACTIVE MAINTENANCE</b>	772 hrs	747 hrs
III.	a.	<b>SORTIES FLOWN</b> (2.5 sorties/day aircraft)	83.1%	86.5% (80.2%-92.9%)
	b.	<b>DOWNTIME IN ACTIVE MAINTENANCE</b>	1020 hrs	934 hrs

Table 2: Comparison of ELCAM vs. TSAR Database (24 a/c, 14-day conflict, 2 mission types).

representative sortie production. It must be emphasized that ELCAM did not include all the resources and subsystems that were in the TSAR model. We already had an indication as to which items were of interest. As is painfully obvious, no analytical technique will discover item A as a "long pole" if A is not included in the analysis.

With this comparison of TSAR and ELCAM as encouragement, the Air Force Operational Test and Evaluation Center (AFOTEC/LG4) at Kirtland AFB, New Mexico, was contacted. The Center agreed to provide a modified B-1B LCOM database. That database turned out to be more detailed than needed, particularly in the area of shop repair (off-equipment task networks). The LCOM database included:

- 16 a/c, 2 missions, 90-day simulation
- 16 personnel types (AFSCs)
- 18 unique parts
- 15 unique pieces of support equipment
- 27 clocks
- 140 tasks

Based on this LCOM data, we constructed the ELCAM database. We also exercised ELCAM's capability to analyze downtimes due to spare parts shortages. This technique uses an approach similar to those used in Dyna-METRIC to account for expected number of parts in pipeline and expected waiting times. This database contained:

- 11 a/c, 1 mission (we eliminated the alert mission), 90 days
- 20 subsystems
- 8 unique parts
- 8 unique pieces of support equipment

Table 3 shows the comparison between LCOM and ELCAM. Again, the actual numbers are not as important as the delineation of the "long poles."

### What ELCAM Is Not

ELCAM is not a simulation. It is an *expected-value*-based model. Therefore, it lacks some of the dynamic characteristics of a simulation. All of the "downing" events are based on scheduled flying hours, not on actual flying hours accomplished. However, an iteration technique is being

investigated to compensate for this drawback. It does not model individual manpower positions but can be used to model groups of skills as resources. It does not handle mission frags and launch windows. It does not handle substitute resources, facilities limitations, maintenance shifts, or resupply capability. It is not a self-contained, in-depth logistics analysis—but it is a first-order approximation.

	LCOM	ELCAM
<b>FLYING HOURS</b>	1611.75	1630.53
<b>% MISSIONS</b>	97%	99%
<b>DESCENDING LIST OF AGE CAUSING DELAYS</b>	HYDRC NITRC PWRC FUELH JACKS FUELT CRANE	HYDRC NITRC PWRC FUELH FUELT CRANE JACKS
<b>TOTAL TIME AWAITING FOR AGE</b>	911.52 HRS	1088.88 HRS
<b>DESCENDING LIST OF PROBLEM PARTS</b>	42AAA 41A*A 11AAA 42AAC 41HBM 13GKO 13AAA 13CAA	41A*A 42AAA 42AAC 11AAA 41HBM 13GKO 13AAA 13CAA
<b>TIME IN PRE-SORTIE</b>	1017.6 HRS	1122.66 HRS
<b>TIME IN POST-SORTIE</b>	3129.65 HRS	3207.6 HRS
<b>TOTAL TIME IN UNSCHED MAINTENANCE</b>	2049.3 HRS	2594.58 HRS

Table 3: LCOM (1 repetition) vs. ELCAM Comparison (Database: 11 a/c, 0.27 sorties/day-a/c, 90 days).

### What ELCAM Is

ELCAM is a simple tool for use by logistics and operations managers, particularly wing commanders in assessing their units' ability to meet mission requirements. The model will allow managers to identify those resources which will be and are critical to getting the job done. It will allow them to quickly make resource tradeoffs and allocations which will maximize their operations.

To validate ELCAM further, we are studying the recently completed Coronet Warrior exercise at Langley AFB, Virginia. We are gathering the results of this exercise and using ELCAM to verify that it will predict what happens in a real-world operational environment.

#### References

1. Liljeqvist, Par; Nilsson, Jan; and Sjodin, Lars. "Operational and Logistic Resource Optimization of Organizational Level." *The Annals of the Society of Logistics Engineers*. Vol. I, No. 1, October 1986, pp. 26-39.
2. Ross, Sheldon M. *Stochastic Processes*. John Wiley & Sons, 1983.

# LOGISTICS ENQUIRER

Enquiring Loggies Want to Know . . .

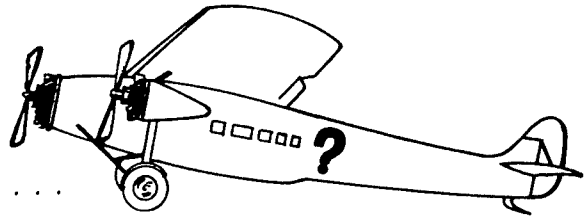

The Logistics Enquirer section of AFJL provides a forum for readers to address important questions to high-level leaders in Air Force logistics. Readers can address questions to specific individuals, or AFJL will select an appropriate respondent. Submitters should identify themselves so as to permit clarification of questions, but we will print only initials if so requested. Our goal is to provide an opportunity for dialogue on crucial issues facing the logistics community. Questions should be broad enough to be meaningful over many months, yet specific enough to be responded to with facts and supportable policy or opinion. Loggies, this is your chance to present some tough, challenging questions to our senior AF leaders.

Respondent: Mr Lloyd Mosemann II, Deputy Assistant Secretary of the Air Force (Logistics), Hq United States Air Force, Washington DC.



Q. The single manager for depot level maintenance is an issue that refuses to go away. Given the fact that interservicing efforts have been less than effective in making the depot system more responsive to modernization, what is your position on the establishment of a single manager as presently proposed in Congress?

A. I could write a book on this and argue on both sides. However, interservicing has been more effective than we are given credit. Only 24% of all depot work has interservicing potential, and most of this could not be further consolidated without adversely impacting mobilization surge capability. About one-third of the truly interserviceable work is already interserviced. Moreover, the Services now have a joint Posture Planning exercise which is enhancing our credibility. On the other hand, those who blindly pursue interservicing on the presumption that economies can be realized are not likely to disappear; hence, we must be prepared to demonstrate how a single manager could adversely impact readiness and responsiveness. On the other hand, we might also be prepared to demonstrate why, if a single manager is thrust upon us, the AF is the best candidate for the single manager of aeronautical materiel. Further, I believe that the best defense against the establishment of a single manager is the rapid joint exploitation by all the Military Services of advanced information systems technology to provide visibility and

oversight capability to existing senior management within the DOD while providing maximum flexibility to local managers to make sensible decisions.

Q. During the final panel session of the 22nd annual International Logistics Symposium and Technical Exhibition, you remarked that one of the biggest problems facing the Air Force was the dearth of software engineers. Would you elaborate for our readers on the seriousness of this problem and potential impacts on the Air Force's ability to meet the challenges of the 21st century?

A. In 1981 the F-16A had seven computer systems, 50 processors, 135K lines of code. Five years later, in 1986, the F-16D has 15 computer systems, 300 processors, and 236K lines of code. The B-1 has more than half a million lines of code. In fact, every ten years there is an exponential order of magnitude increase in the number of software instructions on board our military and space systems. This is actually somewhat deceiving, because the power of each software instruction has also increased by roughly an order of magnitude each ten years.

Today the Air Force alone spends about \$6.3 billion annually on mission critical computer software. In 1995 we project that this amount will be \$14.5 billion. Requirements DOD-wide and in the private sector will increase comparably. But, the number of software personnel will not keep pace. Despite the productivity gains of new software languages, new software tools and environments, and artificial intelligence, there will be a 12% shortage of software personnel nationwide by 1990.

The software crisis is a national problem, and there is no simple solution. Senior management awareness is the first step toward a solution. The Air Force BOLD STROKE program is this first small step. The DOD Software Engineering Institute at Carnegie-Mellon University is working with colleges and universities across the nation to establish curricula for training software engineers.

The software engineer is more than a computer science major. This skill is comparable to that of an architect who is inspired with a vision and translates it into a descriptive architecture from which functional engineers and artisans accomplish the actual development tasks. This initial software engineering function is virtually nonexistent today, and is the largest contributor to the general disarray that accompanies most military (and commercial) software development activities.

I am proud to say that the Air Force is ahead of our society. We have recognized the need and are doing something about it which will benefit not only those of us in the military establishment, but also our whole society.

**Respondent:** Colonel Charles E. Roberson, DCS/Logistics, HQ Air Force Systems Command, Andrews Air Force Base, Maryland.



**Q.** Why can't AFSC Research and Development Centers operate effectively and efficiently within the realm of the standard base supply system (SBSS).

**A.** Numerous studies performed concluded the SBSS could not always support the high priority, low demand, unique requirements of R&D missions. As a result of the studies, AFSC was authorized by HQ USAF to use special support procedures. AFM 67-1, Basic Air Force Procedures, established Logistics Materiel Control Activities (LMCA) for our R&D Centers. AFSCR 67-8 supplements AFM 67-1 with the LMCA operating procedures. These procedures allow LMCAs to bypass the SBSS when that system cannot adequately respond to required delivery dates or it cannot obtain nonstandard items frequently needed in RDT&E projects. In the cases when the requirement is properly verified, our LMCAs are authorized to go directly to contracting to obtain the required items. A command average of 12,300 transactions is generated each month with a low of 150 transactions at one of the smaller LMCAs to a high of 2,500 transactions at one of the larger LMCAs. Seventy-five percent of the workload is through SBSS, 20 percent by direct procurement, and 5 percent supported with imprest funds. In addition, the LMCA provides internal controls needed to reduce fraud, waste, and abuse and effectively manage RDT&E materiel. This was the conclusion of the Air Force Audit Agency after in-depth studies of LMCA management at 11 AFSC installations. LMCAs allow us to optimally support the RDT&E mission requirements while maintaining some control and surveillance over the expendable supplies within the organization. Additionally, the LMCAs provide effective control of more than 436,000 pieces of accountable equipment valued at \$725.5M.

**Respondent:** Brigadier General Richard D. Smith, DCS/Materiel Management, HQ Air Force Logistics Command, Wright-Patterson Air Force Base, Ohio.



**Q.** What is being done to test the assessment and requirements determination capabilities of the Dyna-METRIC Model? How does AFLC plan to use this model in the wholesale logistics business?

**A.** TAC conducted a 30-day flying exercise to test Dyna-METRIC modeling as both an assessment and requirements tool. This exercise was actually a response to the current Air Force initiative to use Dyna-METRIC (versus D029) to compute our war readiness spares kits. The exercise was conducted at Langley AFB VA from 7 July to 5 August 1987. A 24-aircraft, combat-coded F-15 Tactical Fighter Squadron flew for 30 days to match War Mobilization Plan-5 (WMP-5) sorties/hours and planned combat employment scenarios. The unit was limited to those resources provided by the aviation package unit type code (UTC) and all spares support was provided by an existing F-15 independent WRSK; no resupply was permitted. An AFLC working group consisting of AFLC/MMM, AFLC/XRS, LOC/TL, and LMCS/SMW helped TAC/LG plan for this exercise. AFLC and TAC personnel acted as data gatherers during the exercise. AFLC is presently working with TAC/LG and other logistics agencies to analyze the exercise data. Central to this analysis will be the validity of using Dyna-METRIC as a requirements tool for WRSK.

**Respondent:** Major General Richard F. Gillis, Commander, Air Force Acquisition Logistics Center, Wright-Patterson Air Force Base, Ohio.



**Q.** The logistics community has made significant progress toward including logistics requirements in Statements of Need (SON). The recent revisions to AFR 57-1, *Operational Needs, Requirements and Concepts*, in terms of detail and coordination of SONs, jeopardize this process. What is being done to ensure logistics requirements are included? (Leonard Kramer, AFALC/LSX)

**A.** The revisions to AFR 57-1 do limit the length of SONs and therefore reduce much of the detail included. They also have shifted validation from the Air Staff to the user commands. This has been done to enhance the timeliness of the validation process. Coordination with the logistics community still occurs. Detailed logistics requirements will be identified in the System Operational Requirements Document (SORD) and Depot Support Requirements Document (DSRD), which replace the System Operational Concept and the Depot Support Concept. These documents are to be supported by a Requirements Correlation Matrix which will track requirements, including reliability, maintainability and availability parameters, from program initiation through operational test and evaluation. Therefore, we have not eliminated logistics requirements but enhanced our ability to track those requirements through system design and development while reducing the time taken to produce a validated SON.

(The Current Research department will resume in the Winter issue.)



## LOGISTICS WARRIORS

*As a young 2nd Lieutenant fresh out of Radar Maintenance Officer School at Keesler AFB, I was assigned to the 632nd Radar Sq, Roanoke Rapids, NC. There, I had the privilege of working with a man who epitomized the term Logistics Warrior. Although I was his supervisor, I will always remember and be grateful for the lessons on management and life that he taught me. Following are some highlights from the memories of a true Logistics Warrior, CMSgt Cecil H. McClure, USAF, Retired.*

*The Editor*

Born 27 October 1917 in Davilla, TX, he was the son of a West Texas farmer. He grew up during the hard years of the depression and in 1938 there was not enough money to send him to college. So on 7 November he went down to San Antonio and the Army Air Corps's Randolph Field to join up because, "I was interested in airplanes and wanted to learn more about them."

His first military assignment, however, found him as a Dining Hall orderly with a chance to become a student cook. Not feeling particularly enthusiastic about his future in food services, he quickly showed his banter and ability to get things done his own way. He simply went AWOL for a couple of days feeling a certain part of his punishment would be a transfer from the nice, clean Dining Hall to a dirty, outside job like aircraft mechanics. It would be just a matter of time before being put where he wanted to go.

But first, he had to serve a three-month term on the grass mowing detail which was stretched to four when the First Sergeant caught McClure and a buddy "riding the non-riding type lawn mowers." The two friends had rigged up the self-propelled machines one behind the other—one mowing, the other pushing—while the two men perched on top.

After the rather rough beginning, McClure finally was put into aircraft mechanics, precisely the job he wanted.

He trained on the PT-3, PT-11D, and PT-13 aircraft and learned well, as, on 1 February 1941, he was promoted to E-5 while at the Curtiss Wright Technical Institute, Glendale, CA. On 8 May 1941 he was shipped overseas to Nichols Field, the Philippines, eventually being assigned to the 17th Pursuit Squadron. American forces in the Pacific were beginning to prepare for a possible Japanese attack. Conditions were crowded, causing McClure's unit which maintained the P-35s and P-40s to billet in tents.

During the week before 7 December 1941, the top three NCO grades had been told in special Commanders' Calls that the war situation was becoming tense. Sidearms, hard hats, and gas masks were issued and night work required blackout conditions. McClure was inspecting a P-40 at 0200, 8 December 1941, when word of the Pearl Harbor attack came. War was on.

Two days later the Japanese launched attacks that ensured their control of the Philippines. Their strikes against moored American air and naval forces crippled the defensive ability of the islands. McClure was working in a hangar, cowering up a P-40, when the Imperial Air Force hit Nichols Field. A line of incendiary bombs was laid down the hangar row.

The first bomb burst he heard was the one that knocked him from his crew chief stand and sent him scurrying for cover while fire-inducing phosphorus splattered the building. He was saved from

certain death when he darted back to the P-40 to pick up his helmet and gas mask. The hangar door broke loose from its moorings and fell directly on the path where he had started.

As part of the tactical maneuvering Gen MacArthur used to prolong the battle for Luzon, a large force including McClure's unit was moved to the Bataan peninsula while others fought a delaying action from Manila against the pincer action of two advancing Japanese forces.

On Christmas Day 1941, Americans and Filipinos were dug-in the treacherous Bataan terrain ready to take toll of the advancing enemy. McClure drew guard detail that night. He said, "I remember that night in particular. Not so much because it was Christmas but more because of the apprehension and knowledge that it was just a matter of time until we would be captured. I thought much of home and wouldn't have made book on my chances of seeing it again."

History points out that he considered his chances realistically because only a handful of those men on Bataan ever returned home.

The American defense line from Aguilar to Hacienda on the peninsula grudgingly fell and operations were conducted from Bataan Airstrip and a steadily shrinking surrounding area. During this time Lt Col Reggie Vance made supply runs from Bataan to Corregidor in a busted-up P-40 to keep the struggling force alive. Two weeks before the Bataan surrender on 9 April 1942, McClure came down with malaria. "I was on quarters when the surrender came. Quarters meant either in my foxhole or beside it," he reflected.

The events of the next five days have been told and retold many times. "The hike," as McClure called it, has been termed by some historians "The Bataan Death March." The Japanese marched the prisoners of war back up the one-time picturesquely rugged, but now war-torn, landscape of the peninsula.

The already war-weary, diseased, and half-starved men were given only stagnated water and a single ladle-full of rice during the 85-mile march. The heat was stifling. To make matters worse the Japanese were proudly displaying their plentiful spoils of war. Food in cartons and crates lined the road for hundreds of yards in many places.

The men that dropped from the line of march were shot or bayoneted. The Japanese didn't have time to bother with stragglers. McClure related, "On the second day of the march a cavalry brigade took away our canteens to give their horses the water. I did not get a canteen again until we reached O'Donnell Camp."

McClure reported an odd occurrence as the prisoners marched. He said, "It seemed that the family men, the ones with the most to live for, gave up first. It was the young Hell-raisers, the ones that punished their bodies in many ways, that survived. It seemed that many men literally worried themselves to death." The key to survival was to not give up. He said, "Once you gave up you died."

The Japanese guards would allow the POWs to rest from time to time but only long enough to let their leg muscles tighten. They would then rouse the men and force them on. The agony of leg cramps was intense. The drop-out rate increased with each day and only a handful of the 600 men who left Mariveles on 9 April made it the distance to San Fernando and O'Donnell Prison Camp on 14 April.

"We spent four months in O'Donnell Prison Camp. Our main jobs there were to bury the dead and to get water from the two water faucets serving the compound. There were 10,000 to 12,000 men in my area. The prisoners divided up in four-man teams so one of the teams would stand in line 24 hours a day," he said.

He was transferred to Davao Penal Colony, a large farming camp, by way of six months at Cabantuan Prison Camp. His group was put in a forced labor battalion at Davao. They received their best

treatment as POWs. The prisoners worked the abundant rice fields and were given enough food to keep them producing. "They weren't being liberal with us. They wanted to keep our production up," he said.

Also at Davao were members of the 19th Bomb Group captured on Mindanao and the 21st Pursuit Squadron from Bataan. Capt William Dyess of the 21st led the only successful escape attempt. He and two others safely made it back to American forces.

In early 1944, the labor battalion was moved to Lasang Prison Camp to take on a higher priority project. The 750 men quarried coral rock for an airfield under construction. They worked at that job until U.S. forces began bombing the area and putting greater pressure on the Japanese.

August of 1944 found the 750 men on board a freighter bound for Japan. Thus began an experience even more harrowing and deadly than the infamous Death March. McClure described, "It is one of those experiences inscribed indelibly upon my memory."

The men had been marched into the hold and crowded in standing up. They stayed that way ten days making the best of the situation by slinging hammocks on anything available to give everyone a place to lie down.

On the eleventh day, as the ship was slowly working its way up the western coast of Mindanao, they were torpedoed by an American submarine. The sinking vessel was six miles off the coast. Rather than risk letting the Americans reach the safety of Philippine Home Guard forces on Mindanao, the guards opened fire on the prisoners, killing about half the 750 before they reached the water.

Motor launches laden with machine gun armed guards preyed upon the remaining defenseless swimmers. The Japanese worked their way from shore outward trying to keep any prisoner from making the six-mile swim. Only 82 of the 750 men finally made it to the jungle; 56 were relatively able-bodied.

▶ Continued from 21

with the US Army indicated they wanted a battery of missiles and components on C-5 aircraft, standing alert, and ready to launch on notification. This proved to be an unacceptable airlift plan for a number of reasons. First, the onload location could not accommodate the 10 to 15 C-5 aircraft required to move the cargo. Thus, the C-5s would have to load and position to an en route base where they would be secure until the launch order. This too was unacceptable due to the nature of the cargo. Pershing II solid fuel boosters were a DOD Class A explosive of over 25,000 pounds and very few bases have the munitions safety clearance to park more than one or two aircraft loaded with these missiles. Finally, the offload location in Germany could not handle the volume of aircraft such a move would require without, first, drawing attention to the operation and, second, severely impacting normal operations. After these constraints were explained, the Army developed a more supportable deployment plan. When notified to deploy, the operation proceeded smoothly and the entire operation was a success. Thus, advance notice and close planning between airlift directors and users resulted in an effective use of airlift aircraft to project US power. (9)

Early notification of airlift requirements is the most important part of an airlift operation. It will enable MAC to analyze the best course of action and give the theater command a more accurate projection of how support will be provided. Likewise, timely information on changing conditions or requirements will enable airlifters to shift gears and use airlift forces in the most effective manner possibly.

## Summary

Airlift resources are limited and will remain so for years to come. By maximizing existing capabilities though effective

Fall 1987

Surviving the swim and butchery, McClure eventually contacted Philippine Home Guard units. He said, "I wasn't quite sure they were friendly at first. I kept them under observation for awhile the morning after the sinking just to be sure."

He stayed for about a month with guerilla forces, living with the family of Hsin Kee. Gen MacArthur ordered all able-bodied survivors to be evacuated to Australia for medical evaluation. McClure went—reluctantly.

In Australia he was promoted to E-6 and given a thorough examination for diet deficiency disease and possible permanent physical damage. He was then put on a troop carrier headed for the U.S.

McClure continued to work as a crew chief on the B-25, B-26, B-17, C-47, and other twin-engine aircraft until 1950. In February 1948 he logged 134 hours flying time. He served tours at Wright-Patterson Field, OH; Kelly Field, TX, and Pyote Storage Base, TX. He was promoted to Master Sergeant on 6 March 1946.

Rather than go to work on larger multi-engine aircraft, he retrained into the communications-electronics career field at Keesler Technical Training Center, MS. He held maintenance supervisory positions in Taiwan, Okinawa, and Roanoke Rapids AFS, NC.

From 1955 to 1960, he was a technical writer for nonresident training at Keesler. He was promoted to Senior Master Sergeant and Chief Master Sergeant in the first increments during 1958 and 1959.

When asked at his retirement, on 30 April 1970, what he considered the greatest need of service men today, he replied, "People in the military service should keep themselves fairly well-informed on world affairs so they can make up their own minds and be possibly better prepared for war-time conditions than we were."

*Daily Herald*, Roanoke Rapids, N.C., 30 April 1970.

planning, we will be able to project US power on a global scale more effectively. This ability to project US power rapidly in peace might also avert a war. Although Sun Tzu, the ancient strategist, did not have the capability we have to project power, he understood power:

For to win one hundred victories in one hundred battles is not the acme of skill. To subdue the enemy without fighting is the acme of skill. (10:77)

Or, stated another way: "Not today comrade, not today." (5:1)

### Articles and Periodicals

1. "CINCMAC Discusses Airlift Issues." *Airlift*, Vol. 6, No. 2 (Spring 1984), pp. 4-9.
2. "A Tangled Exchange of Threats." *Time*, Vol. 121, No. 9 (28 February 1983), p. 28.
3. Zelikow, Philip D. "Force Without War, 1975-82." *The Journal of Strategic Studies*, Vol. 7, No. 1 (March 1984), pp. 29-50.

### Official Documents

4. Military Airlift Command. *MACR 55-1 Airlift Operations*. Scott AFB, Illinois, 14 May 1981.

### Other Sources

5. Anonymous. ACSC definition of deterrence. September - October 1986.
6. Barzellone, Steve, Major, USAF. Special Airlift Director, HQ MAC, Scott AFB, Illinois Letter, 10 Nov 1986.
7. Romaine, T. H., Lt Colonel, USAF. Team Spirit 87 Exercise, Director, HQ MAC, Scott AFB, Illinois. Memo, 10 Nov 1986.
8. Sawyer, Keith, Colonel, USAF. Former Chief, Airlift Management Division, HQ MAC, Scott AFB, Illinois. Telecons, 27 October 1986 - 7 November 1986.
9. Todd, David F., Major USAF. Former Special Airlift Director, HQ MAC, Scott AFB, Illinois, observations, July 1981 - October 1984.

### Books

10. Tzu, Sun. *The Art of War*, trans Samuel B. Griffin. London, England: Oxford University Press, 1963.

41

## General Hansen Pledges AFLC Commitment to Continued Readiness

*“We have developed the finest weapon systems in the world to allow our airmen, who both fly and support them, to have the razor’s edge against an enemy that outnumbered them in almost every category.*

*“But acquisition of those fine weapon systems is only part of the warfighting equation. To make those weapon systems ready and to ensure they have the sustainability that’s necessary to carry the fight to a conclusion, and win, is the responsibility of Air Force Logistics Command.”*

*Air Force Journal of Logistics*  
Air Force Logistics Management Center  
Gunter AFS, Alabama 36114-6693

---

OFFICIAL BUSINESS  
PENALTY FOR PRIVATE USE \$300  
RETURN POSTAGE GUARANTEED

BULK RATE POSTAGE & FEES PAID USAF PERMIT NO. G-1
--