

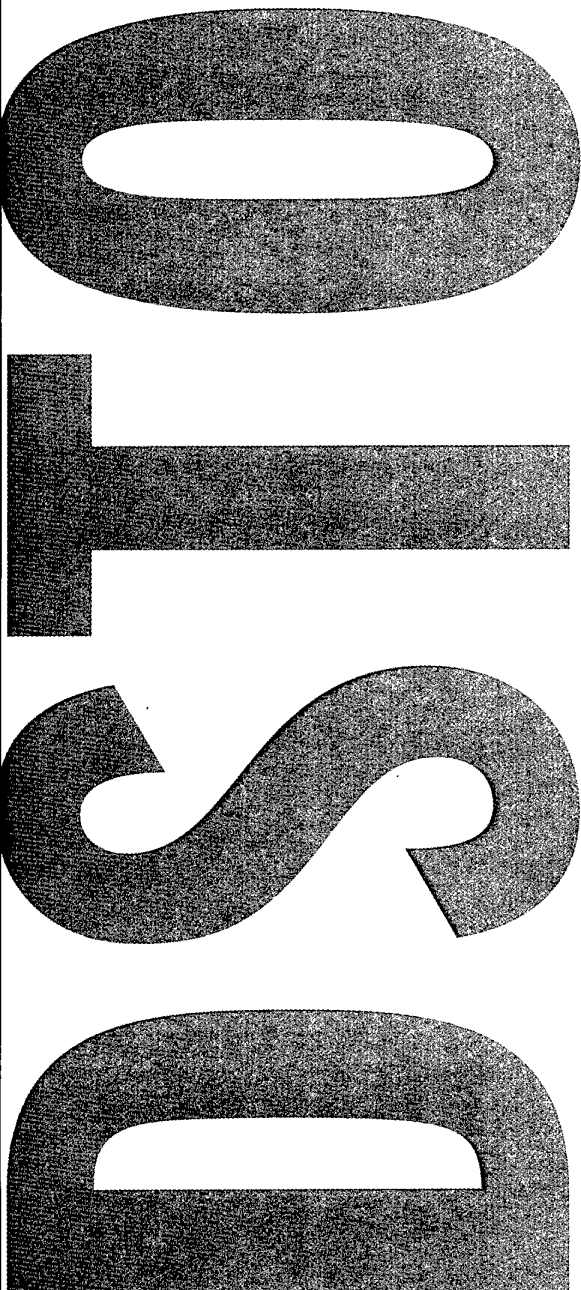

Australian Government
Department of Defence
Defence Science and
Technology Organisation



Dynamic Impulse Calibration of 100 MPa Blast Pressure Transducers

Frank Marian, Phillip Box
and Andrew McLean

DSTO-TN-0525

DISTRIBUTION STATEMENT A
Approved for Public Release
Distribution Unlimited

BEST AVAILABLE COPY

20040617 034



Australian Government
Department of Defence
Defence Science and
Technology Organisation

Dynamic Impulse Calibration of 100 MPa Blast Pressure Transducers

Frank Marian, Phillip Box and Andrew McLean

Maritime Platforms Division
Platforms Sciences Laboratory

DSTO-TN-0525

ABSTRACT

Maritime Platforms Division (MPD) has manufactured a calibrator for determining the sensitivities of air blast and underwater pressure transducers with nominal ranges up to 100,000 kPa, which is the design limit of the transfer standard used. This paper describes the design of the calibrator, the process and analysis used to provide traceable calibration results.

RELEASE LIMITATION

Approved for public release

AQ F04-09-0843

Published by

*DSTO Platforms Sciences Laboratory
506 Lorimer St
Fishermans Bend, Victoria 3207 Australia*

Telephone: (03) 9626 7000

Fax: (03) 9626 7999

© Commonwealth of Australia 2003

AR-012-971

November 2003

Dynamic Impulse Calibration of 100 MPa Blast Pressure Transducers

Executive Summary

A characteristic of an explosive detonating in air or underwater is the resultant shock wave. The measurement of the shock wave parameters is an important tool in any research regarding explosive performance or structural response. Commercial piezoelectric or piezoresistive transducers are used to measure these parameters. The resultant electrical signals are proportional to the pressures to which the transducers are subjected. The sensitivity of the transducer is the inherent property that must be known for the accurate interpretation of the electrical signal. The sensitivity of the transducers can change over time due to degradation of the piezo-crystal and may be attributed to the development of micro cracks within the crystal. Typically the transducers become less sensitive as more cracks develop or propagate. The transducers therefore need to be calibrated, traceable to a recognised standard on a regular basis, ideally prior to all experiments.

Maritime Platforms Division (MPD) has manufactured a calibrator for determining the sensitivities of air blast and underwater pressure transducers with nominal ranges up to 100,000 kPa, which is the design limit of the transfer standard used. This paper describes the design of the calibrator, and the process and systems used to provide traceable calibrations results.

Authors

Frank Marian

Maritime Platforms Division

Frank commenced work at PSL in 1969 and has been involved in a diverse range of activities. Since 1987 he has worked in the area of specialised instrumentation and has conducted field and laboratory experiments to measure transient parameters associated with air and underwater blast. In more recent times his work has focused on experiments related to structural response of naval vessels and hardware to underwater detonations and is responsible for the PSL Underwater test facility in Melbourne.

Phillip Box

Maritime Platforms Division

Phillip has evaluated explosives and their effects on platforms, structures and components, including the measurement of shock and blast parameters, from detonations in air and underwater for over 23 years. Phillip is currently researching vulnerability and recoverability of naval platforms.

Andrew McLean

Maritime Platforms Division

Andrew McLean has worked at PSL for seventeen years. He has spent the last ten years with the Specialised Instrumentation Group. He carries out high-speed instrumentation work as part of shock and vibrations studies.

Contents

1. INTRODUCTION	1
2. CALIBRATOR DESCRIPTION	1
2.1 Design	1
2.2 Drop-weights	3
3. TRANSDUCERS	3
3.1 Reference Transducer	3
3.1.1 Underwater Transducers.....	3
3.1.2 Air Blast Transducers.....	5
3.2 Preparation and Fitting Transducers	5
3.2.1 Preparing the Transducers	5
3.2.2 Installing the Transducer into the Calibrator	5
3.3 Re-assembly of Underwater Transducers	5
4. EQUIPMENT FOR CALIBRATION	6
5. CALIBRATION PROCEDURE	8
6. CALIBRATION ANALYSIS	8
7. FUNCTIONALITY TESTS	10
8. CONCLUSION	10
9. REFERENCES	10

1. Introduction

A characteristic of an explosive detonating in air or under-water is the resultant shock wave. The measurement of the shock wave characteristics is an important tool in any research regarding explosive performance or structural response. Commercial piezoelectric or piezoresistive transducers are used to measure these parameters. The resultant electrical signals are proportional to the pressures to which the transducers are subjected. The sensitivity of the transducer is the inherent property that must be known for the accurate interpretation of the electrical signal. The sensitivity of transducers can change over time due to degradation of the piezo-crystal, which may be attributed to the development of micro-cracks within the crystal. Typically the transducers become less sensitive as more cracks develop or propagate. The transducers therefore need to be calibrated, traceable to a recognised standard on a regular basis, ideally prior to and after all experiments.

Maritime Platforms Division (MPD) has manufactured a calibrator for determining the sensitivities of air blast and underwater pressure transducers with nominal ranges up to 140,000 kPa. This paper describes the design of the calibrator, the procedures used to provide traceable calibrations results.

2. Calibrator Description

2.1 Design

The Defence Science and Technology Organisation (DSTO) designed calibrator is similar to a commercial impulse calibrator manufactured by PCB Piezotronics, model number 913B02. It couples the concept of transferring kinetic energy, via a dropped weight to a hydraulic pressure. The PCB unit consists of a brass block with an internal inverted 'T' channel shown in Figure 1. Two tapped ports in the horizontal plane are used to fit the transducer under test and a reference transducer. The vertical portion of the cavity is machined to suit a piston. The entire channel is filled with low viscosity silicon oil. Weights are dropped onto the piston to generate a pressure pulse in the silicone oil. This produces a half-sine signal from both transducers, which are compared to determine the sensitivity of the transducer under test.

The DSTO designed calibrator incorporates an inverted "Y" shape internal channel shown in Figure 2 instead of the "T" shaped channel. This alleviates a problem of air being trapped in the channel, a problem continually experienced with the commercial design. The presence of air can create unwanted signal distortions and result in, if adjacent to the sensing element, damage to the transducer. The two tapped ports for mounting the transducer are at an angle of 45 degrees to the vertical channel. This design together with the absence of sharp corners minimises the possibility of air entrapment within the channel.

When the weight impacts the piston it imparts a compression wave through the silicon oil onto the sensing elements of both the reference transducer and the transducer under test. Using different masses released from a range of heights, the magnitude of the

compression wave can be varied. A guide-tube manufactured from a length of aluminium tubing fits around a collar at the top of the calibrator to centrally guide the weight onto the piston. The calibrator with three weights and the guide tube is shown in Figure 3.

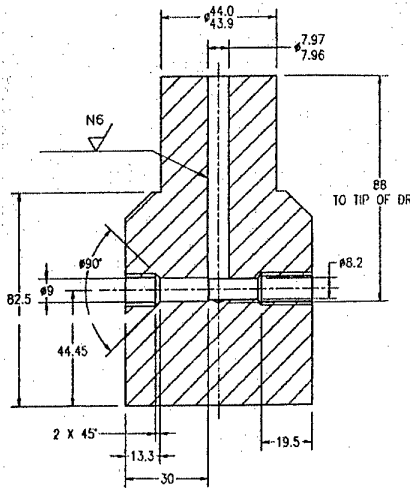

Figure 1: "T" shaped channel

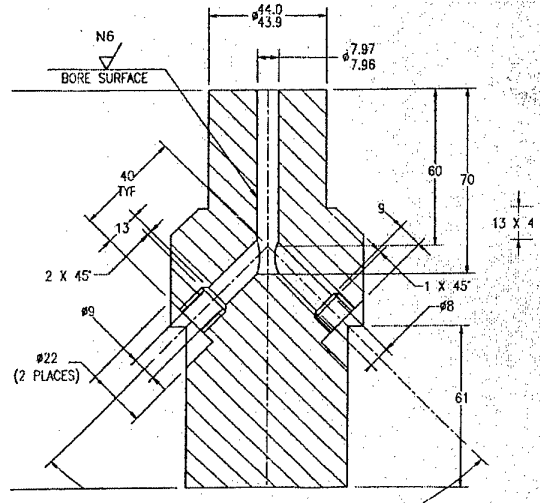

Figure 2: "Y" shaped channel

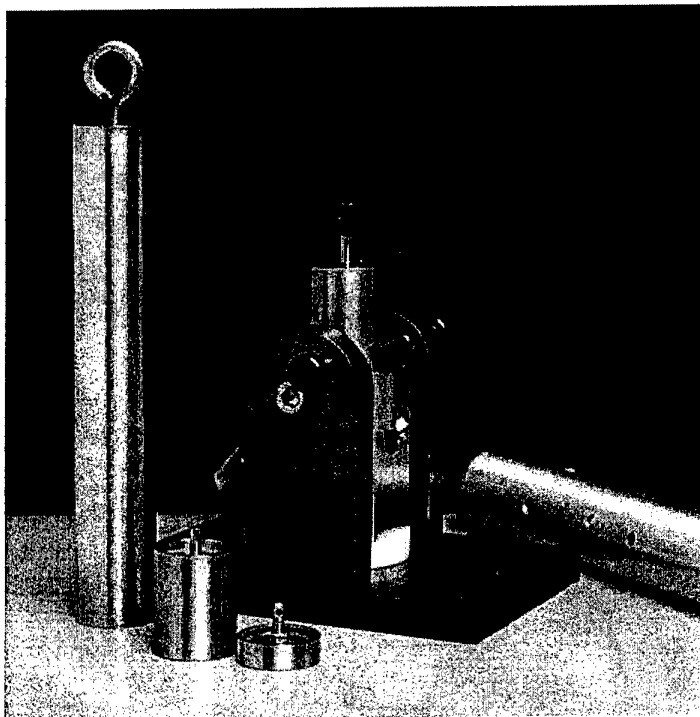

Figure 3: PCB Piezotronics, model number 913B02 Impulse Calibrator with three weights and guide tube (on side)

2.2 Drop-weights

Three drop-weights, 150g, 750g and 3900g, which when dropped from predetermined heights cover the dynamic pressure range of the transducers, have been manufactured for the calibration procedure. These can be released from seven fixed drop heights machined in the tube. The nominal peak pressure for the three weights and seven-drop heights are shown in Table 1.

Table 1 Nominal Peak Pressures for each Drop-weight

Hole No.	150g Mass	750g Mass	3900g Mass
1	1300kPa	11700kPa	36500kPa
2	2200kPa	19300kPa	55150kPa
3	5100kPa	24100kPa	68300kPa
4	6450kPa	29150kPa	89650kPa
5	6800kPa	33100kPa	108950kPa
6	7600kPa	36550kPa	-----
7	8300kPa	40700kPa	-----

The nominal range of the transducers typically used is 7000kPa, 35,000kPa, and 70,000kPa. A limited number of transducers are used with a nominal range to 140,000kPa. The drop-weights have been specifically designed to calibrate over these ranges. Design constraints limit the use of the calibrator to ranges up to 100,000kPa. Above this pressure, damage has been sustained in the piston and seal failure has occurred.

3. Transducers

3.1 Reference Transducer

The calibrator uses a transfer standard manufactured by PCB Piezotronics in the USA as a reference in one of the transducer ports. It is a model 136A linear volumetric tourmaline pressure sensor designed to accurately measure rapidly changing hydraulic pressures up to 140,000 kPa. It is constructed with a single tourmaline crystal suspended between two steel supports, there is no diaphragm or housing so the crystal is directly exposed to a pressure pulse which makes it an excellent transfer standard for use in hydraulic impulse type calibrators. The crystal is sealed with a light epoxy coating and is recommended for use only in an electrically non-conductive oil environment [1].

The transfer standard is calibrated traceable to the National Institute of Standards and Technology (NIST) through project No. 822/255136-95 in the USA in compliance with ISO 10012-1. The transfer standard is regularly re-calibrated and certified to this standard.

3.1.1 Underwater Transducers

PCB in the USA manufactures the underwater pressure transducers most commonly used by DSTO. The transducers are Integrated Circuit Piezoelectric (ICP) types; model

No 138. The transducers use a tourmaline crystal in an insulating silicone oil environment housed in a clear Tygon tube. The tube is approximately 10mm in diameter. The crystal is positioned approximately mid-way between the cable connector end of the transducer, in which the electronic amplifier is housed, and the nylon plugged or hermetically sealed end.

Two transducer configurations, Figure 4 and Figure 5 are commonly used. The configuration with the nylon plug is used when the transducers are to be suspended vertically with a weight tied through the hole in the nylon plug. This is the more conventional arrangement when measuring underwater shock waves. The arrangement shown in Figure 5 is used when other orientations are required.

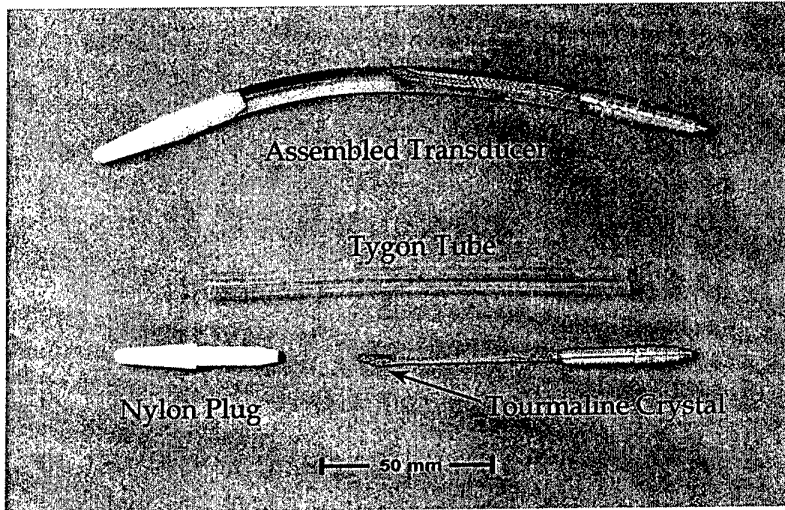

Figure 4: A PCB 138 series underwater pressure transducer, assembled and unassembled

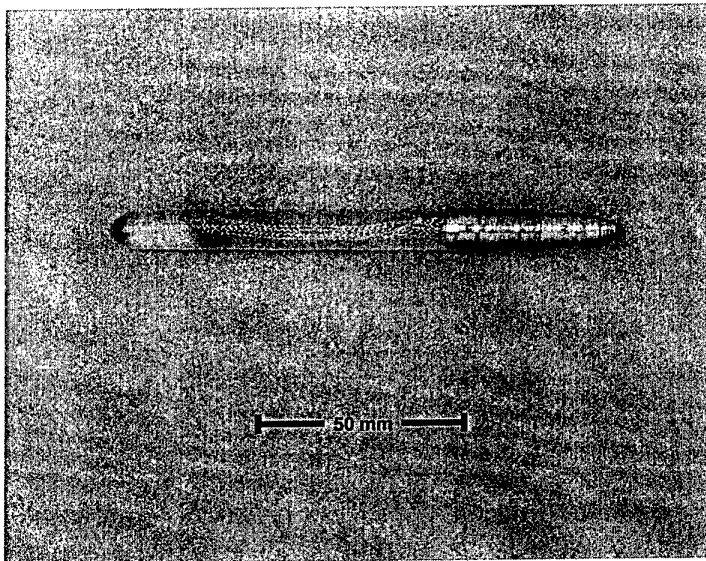

Figure 5: A PCB 138 modified series underwater pressure transducer

3.1.2 Air Blast Transducers

Air blast transducers are sealed units that cannot be disassembled for calibration. The piezo crystals are stimulated via a diaphragm. They are directly mounted into the threaded ports of the calibrator so that the diaphragm of the transducer is exposed to the oil. These transducers can also be used to measure underwater blast parameters and shock loading, on hullplates or structures, resulting from underwater detonations. They are adversely affected by moisture, which can alter their time constant.

3.2 Preparation and Fitting Transducers

3.2.1 Preparing the Transducers

Prior to calibration, the underwater pressure transducers are disassembled as shown in Figure 4, washed in alcohol and heated in a vacuum oven at 60° C and 0.02 Torr for several hours to remove any moisture.

Before calibration, air blast transducers are also heated in a vacuum oven at 60°C and 0.02 Torr for several hours to remove any moisture. The procedures used are referenced in the PCB instructions [2].

3.2.2 Installing the Transducer into the Calibrator

The reference transducer and piston are initially fitted into the calibrator. The calibrator is then turned and locked on its side and the channel slowly filled with silicone oil that has been degassed in a vacuum oven. Underwater pressure transducers do not have a mounting thread and are fitted into a specifically designed manifold. The crystal and screened leads are first wetted with silicon oil and are slowly pushed into the manifold. This process is undertaken carefully to prevent the introduction of air bubbles. With the piston near the top of its stroke the transducer is loosely mounted into the cavity. While some hand pressure is applied to the piston, the transducer is firmly secured into the calibrator. This pushes oil past the transducer locking thread as it is installed preventing the entrapment of air bubbles.

Air blast transducers are screwed directly into the calibrator using the appropriate mounting adaptor and using a similar process to avoid the entrapment of air bubbles.

A small brass seal is fitted between the transducer and the manifold to prevent oil leaking past the transducer once it is tightened in place. Significant force is required to prevent leakage. The seal, which consequently is deformed, needs to be replaced every time a transducer is calibrated.

3.3 Re-assembly of Underwater Transducers

Once calibrated, the underwater transducers are removed from the calibrator and stored under vacuum, to avoid moisture contamination prior to their reassembly. Assembly of the transducer shown in Figure 4, and is as follows. The braided sensing element is first wetted with silicon oil and inserted in to the tygon tube, the tube is then filled with degassed silicone oil and placed under vacuum to remove entrapped air. The tube is secured around the connector end of the transducer and the nylon plug using monofilament-fishing line.

Assembly of the transducers in the configuration shown in Figure 5 involves inserting the braided sensing element into oil filled tygon tube and loosely securing the two together. The assembly is then placed under vacuum for 30 minutes to remove any air prior to securing the tube.

4. Equipment for Calibration

The instrumentation, Figure 6 (a), required for calibrating the transducers is similar to that used for blast measurements. The transducer is connected to a digital acquisition system, via an amplifier if necessary, capable of recording at 100000 samples per second.

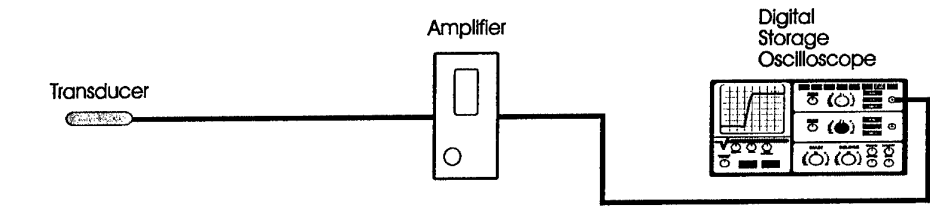

(a) Pressure Calibration Setup

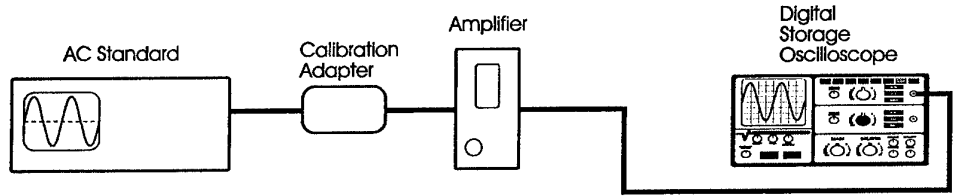

(b) Voltage Calibration Setup

Figure 6: Calibration Instrumentation

To account for any inaccuracies, the complete electronic acquisition system also needs to be calibrated, with reference to a traceable standard. A typical configuration for calibrating an acquisition system is shown in Figure 6(b). To calibrate the acquisition system the transducer is replaced with a small passive circuit that allows an electrical signal of known amplitude to be recorded. The signal is generated by an A.C. standard, which is an electronic device, which provides a very accurate AC electrical signal of a selectable magnitude and frequency. The A.C. standard is traceable to the National Association of Testing Authorities, Australia (NATA) standards. The calibration circuit is shown in Figure 7.

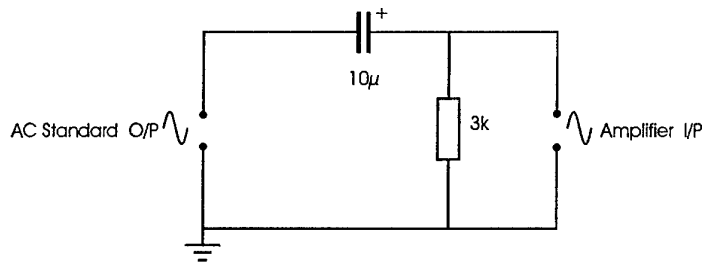

Figure 7: Calibration Adaptor Circuit

The A.C. Standard is configured to produce a sine wave signal of $1.0 V_{RMS}$ at 3 kHz. The signal is recorded by the acquisition system and the amplitude measured. For a signal of $1.0 V_{RMS}$ at 3 kHz, and an amplifier gain of 1, the output voltage (V_{PP}) measured on the Digital Storage Oscilloscope (DSO), Figure 8, is given by:

$$\begin{aligned} V_{PP} &= V_{RMS} \times 1.414 \times 2 \times \text{gain} \\ &= 1.0 \times 1.414 \times 2 \times \text{gain} \\ &= 2.828 V \end{aligned}$$

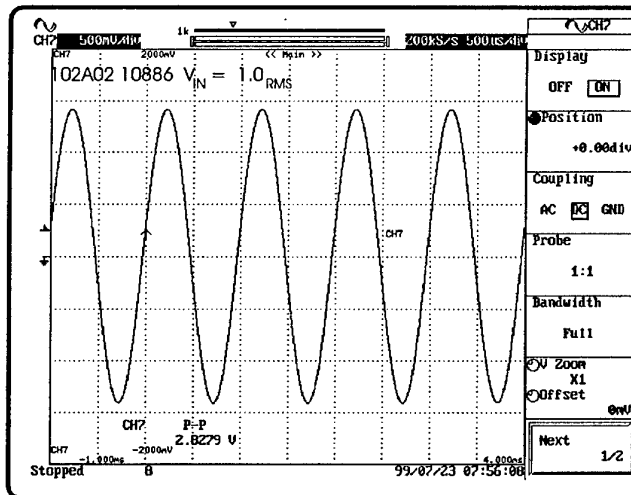

Figure 8: DSO Display of AC Standard Signal

The voltage measured is recorded, along with the set A.C. Standard output voltage and the amplifier gain. These are used to correct the measurements of the calibration pressure pulses using the following formula:

$$V_{CORRECTED} = V_{MEASURED} \times \left(\frac{V_{CAL} \times 2.828 \times \text{gain}}{V_o} \right)$$

Where:

V_{CAL}	is the RMS voltage set on the AC Standard
V_O	is the measured peak-to-peak voltage of the sine wave recorded on the DSO
$V_{MEASURED}$	is the pressure pulse voltage reading from the DSO
$V_{CORRECTED}$	is the corrected value of the pressure pulse voltage

In the laboratory calibration process, a DSO is used as part of the acquisition system together with any signal conditioning. Field acquisition systems comprising Digistar® digital data recorders can involve long cable runs, up to 1.5 km, between the transducer and the data recorder. Past experience has shown that there is negligible influence on the transducer signal due to the resistance of long cable runs. This is due to the high input impedance ($1M\Omega$) of the Digistars to record the data.

5. Calibration Procedure

The reference transducer and transducer to be calibrated are mounted in the calibrator housing as previously described and the drop-weight guide tube is fitted to the housing. The drop weights, corresponding to the nominal pressure range of the transducer to be calibrated, are raised using nylon line attached to a lifting ring and are supported at the fixed height by a steel rod inserted through holes in the guide tube. When the instrumentation is ready to acquire data the rod is removed and the weight allowed to fall freely along the guide tube onto the piston. The drop from each height is repeated at least once.

The electrical signals from both transducers are acquired using a digital oscilloscope. The signals are a half sine wave pulse with a peak voltage dependent on the pressure generated. The reference transducer signal is a negative pulse and the other transducer signals are positive pulses, as shown in Figure 9. The peak voltages are measured and these results entered into an Excel spreadsheet for analysis.

6. Calibration Analysis

The acquired data is entered into a Microsoft Excel spreadsheet, Figure 10, which allows straightforward processing of the calibration results. Graphical analysis using the linear regression algorithm in Microsoft Excel calculates the sensitivity (mV/psi and mV/kPa) of the transducer and confirms its linearity across the operational range. All calibration drops are included in the calculation and the linear equation is forced through zero.

User input is required to furnish information required to calculate the transducer sensitivity and allow complete traceability of the data and results. The transducer model number, serial number, A.C. Standard V_{OUT} and the $V_{MEASURED}$ from the voltage calibration for both transducers are entered, along with the amplifier settings and the peak voltages from both transducers for each of the drop heights. Function buttons

allow printing of the calibration page and directs the results to a calibration file for archiving. The file name is derived from the transducer type and serial number previously entered.

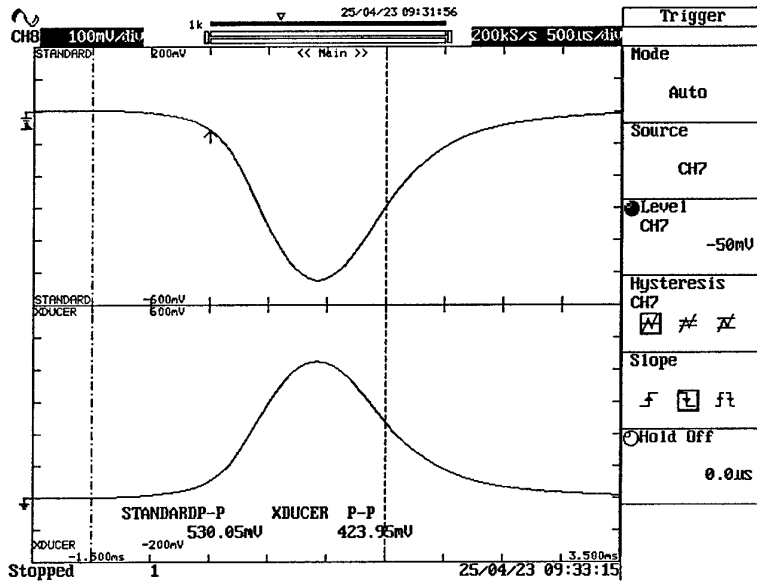

Figure 9: Typical display from a calibration test drop

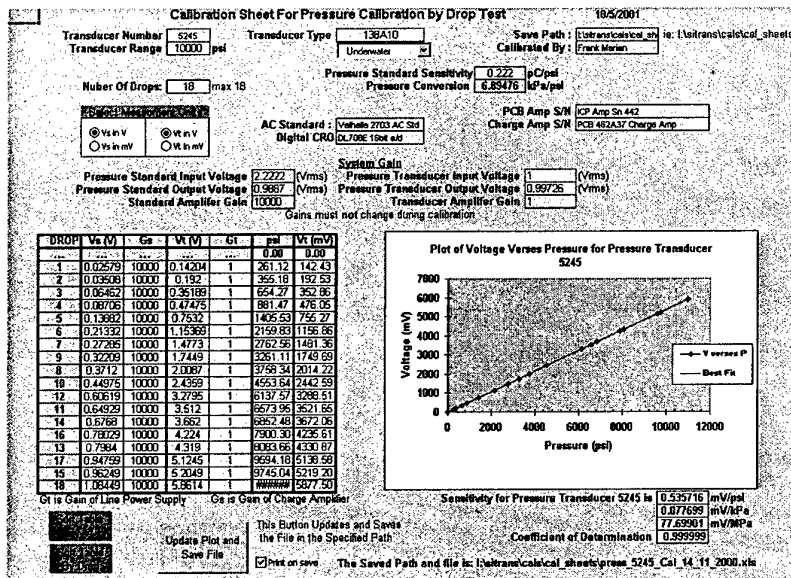

Figure 10: Calibration data sheet

7. Functionality Tests

The pulses produced by mechanical calibration techniques cannot produce the same characteristics as an explosive shock wave and it is therefore essential that functionality tests form part of the overall calibration process. Explosive shock waves are characterised by a rapid rise time, in the order of nanoseconds and durations as small as a few milliseconds. In addition to the laboratory calibration technique, functionality tests on the underwater pressure transducers to evaluate their response to a shock wave generated by an explosive detonation are conducted using small explosive charges. This enables vetting of transducers that may appear, on the basis of the mechanical calibration results, to function as expected but no longer have the response characteristics to accurately measure explosive shock waves.

8. Conclusion

The transducer calibration procedure as outlined in this paper produces sensitivities for transducers that are traceable to two secondary standards, these being the AC Voltage Standard and the Reference Transducer. These two secondary standards are regularly NATA and NIST certified and as such the sensitivities of the transducers are traceable to recognised standards.

The calibration histories of the transducers are stored on the computer network and hardcopies of each calibration are placed on the appropriate file for the experiment being conducted. This ensures accuracy and complete traceability of all pressure results.

Due to design constraints, the calibrator at present can only be used for calibrating transducers with dynamic ranges of up to 100,000 kPa. Above this pressure damage can occur to the piston and oil leakage past the transducer seal has been observed. Calibration at higher pressures is not insurmountable but would necessitate further design work being undertaken. The transfer standard currently used has an upper calibration limit of 140,000kPa and if higher calibration pressures were required a more robust standard would be required.

Whilst transducer sensitivities can be accurately determined, the laboratory technique does not provide complete information on the functionality of the transducer. For this reason it is imperative that explosive tests be performed as part of the calibration process to evaluate transducer performance in measuring typical blast parameters.

9. References

1. PCB manual for the transfer standard
2. G-0001. General Guide to ICP Instrumentation, PCB Piezotronics, INC.

DISTRIBUTION LIST

Dynamic Impulse Calibration of 100 MPa Blast Pressure Transducers

Frank Marian, Phillip Box and Andrew McLean

AUSTRALIA

DEFENCE ORGANISATION

	No. of copies
S&T Program	
Chief Defence Scientist	} shared copy
FAS Science Policy	
AS Science Corporate Management	
Director General Science Policy Development	
Counsellor Defence Science, London	Doc Data Sheet
Counsellor Defence Science, Washington	Doc Data Sheet
Scientific Adviser to MRDC, Thailand	Doc Data Sheet
Scientific Adviser Joint	1
Navy Scientific Adviser	Doc Data Sht & Dist List
Scientific Adviser - Army	Doc Data Sht & Dist List
Air Force Scientific Adviser	Doc Data Sht & Dist List
Scientific Adviser to the DMO M&A	Doc Data Sht & Dist List
Scientific Adviser to the DMO ELL	Doc Data Sht & Dist List
Director of Trials	1
Platforms Sciences Laboratory	
Chief of Maritime Platforms Division	1
Research Leader SPS: Dr. D. Saunders	1
Task Manager: Mr. Paul Elischer	1
Author(s): Mr. Frank Marian	1
Mr. Phillip Box	1
Mr. Andrew McLean	1
Mr. Andrew Krelle	1
Mr. Darren Wiese	1
Mr. Chris Townsend	1
Mr. George Yiannakopoulos	1
Mr. Ken Schebella	1
Mr. Robert Hart	1
Mr. Tim Clark	1
DSTO Library and Archives	
Library Maribyrnong	Doc Data Sheet
Library Edinburgh	1 & Doc Data Sheet
Australian Archives	1

Capability Systems Division

Director General Maritime Development Doc Data Sheet
Director General Aerospace Development Doc Data Sheet
Director General Information Capability Development Doc Data Sheet

Office of the Chief Information Officer

Deputy CIO Doc Data Sheet
Director General Information Policy and Plans Doc Data Sheet
AS Information Structures and Futures Doc Data Sheet
AS Information Architecture and Management Doc Data Sheet
Director General Australian Defence Simulation Office Doc Data Sheet

Strategy Group

Director General Military Strategy Doc Data Sheet
Director General Preparedness Doc Data Sheet

HQAST

SO (Science) (ASJIC) Doc Data Sheet

Navy

SO (SCIENCE), COMAUSNAVSURFGRP, NSW Doc Data Sht & Dist List
Director General Navy Capability, Performance and Plans, Navy Headquarters
Doc Data Sheet
Director General Navy Strategic Policy and Futures, Navy Headquarters
Doc Data Sheet

Army

ABCA National Standardisation Officer, Land Warfare Development Sector,
Puckapunyal e-mailed Doc Data Sheet
SO (Science), Deployable Joint Force Headquarters (DJFHQ) (L), Enoggera QLD
Doc Data Sheet
SO (Science) - Land Headquarters (LHQ), Victoria Barracks NSW
Doc Data & Exec Summ

Intelligence Program

DGSTA Defence Intelligence Organisation 1
Manager, Information Centre, Defence Intelligence Organisation PDF only
Assistant Secretary Corporate, Defence Imagery and Geospatial Organisation
Doc Data Sheet

Defence Materiel Organisation

Head Airborne Surveillance and Control Doc Data Sheet
Head Aerospace Systems Division Doc Data Sheet
Head Electronic Systems Division Doc Data Sheet
Head Maritime Systems Division Doc Data Sheet
Head Land Systems Division Doc Data Sheet
Head Industry Division Doc Data Sheet
Chief Joint Logistics Command Doc Data Sheet
Management Information Systems Division Doc Data Sheet
Head Materiel Finance Doc Data Sheet

Defence Libraries

Library Manager, DLS-Canberra	Doc Data Sheet
Library Manager, DLS - Sydney West	Doc Data Sheet

OTHER ORGANISATIONS

National Library of Australia	1
NASA (Canberra)	1

UNIVERSITIES AND COLLEGES

Australian Defence Force Academy	
Library	1
Head of Aerospace and Mechanical Engineering	1
Hargrave Library, Monash University	Doc Data Sheet
Librarian, Flinders University	1

OUTSIDE AUSTRALIA**INTERNATIONAL DEFENCE INFORMATION CENTRES**

US Defense Technical Information Center	2
UK Defence Research Information Centre	2
Canada Defence Scientific Information Service	e-mail link to pdf
NZ Defence Information Centre	1

ABSTRACTING AND INFORMATION ORGANISATIONS

Library, Chemical Abstracts Reference Service	1
Engineering Societies Library, US	1
Materials Information, Cambridge Scientific Abstracts, US	1
Documents Librarian, The Center for Research Libraries, US	1

SPARES	5
--------	---

Total number of copies	38 (36 paper and 2 pdf)
-------------------------------	---------------------------------

DEFENCE SCIENCE AND TECHNOLOGY ORGANISATION					
DOCUMENT CONTROL DATA				1. PRIVACY MARKING/CAVEAT (OF DOCUMENT)	
2. TITLE Dynamic Impulse Calibration of 100 MPa Blast Pressure Transducers			3. SECURITY CLASSIFICATION (FOR UNCLASSIFIED REPORTS THAT ARE LIMITED RELEASE USE (L) NEXT TO DOCUMENT CLASSIFICATION) Document (U) Title (U) Abstract (U)		
4. AUTHOR(S) Frank Marian, Phillip Box and Andrew McLean			5. CORPORATE AUTHOR Platforms Sciences Laboratory 506 Lorimer St Fishermans Bend Victoria 3207 Australia		
6a. DSTO NUMBER DSTO-TN-0525		6b. AR NUMBER AR-012-971		6c. TYPE OF REPORT Technical Note	
				7. DOCUMENT DATE November 2003	
8. FILE NUMBER 510/207/1217	9. TASK NUMBER RDI 02/162	10. TASK SPONSOR CMPD	11. NO. OF PAGES 10		12. NO. OF REFERENCES 2
13. URL on the World Wide Web http://www.dsto.defence.gov.au/corporate/reports/DSTO-TN-0525.pdf			14. RELEASE AUTHORITY Chief, Maritime Platforms Division		
15. SECONDARY RELEASE STATEMENT OF THIS DOCUMENT <i>Approved for public release</i>					
OVERSEAS ENQUIRIES OUTSIDE STATED LIMITATIONS SHOULD BE REFERRED THROUGH DOCUMENT EXCHANGE, PO BOX 1500, EDINBURGH, SA 5111					
16. DELIBERATE ANNOUNCEMENT No Limitations					
17. CITATION IN OTHER DOCUMENTS Yes					
18. DEFTTEST DESCRIPTORS Calibration, Pressure Guages, Transducers					
19. ABSTRACT Maritime Platforms Division (MPD) has manufactured a calibrator for determining the sensitivities of air blast and underwater pressure transducers with nominal ranges up to 100,000 kPa, which is the design limit of the transfer standard used. This paper describes the design of the calibrator, the process and analysis used to provide traceable calibration results.					