



EDGEWOOD

CHEMICAL BIOLOGICAL CENTER

U.S. ARMY SOLDIER AND BIOLOGICAL CHEMICAL COMMAND

ECBC-TR-291

**BIODEGRADATION OF HYDROLYZED MUSTARD
FROM AN ASSEMBLED CHEMICAL WEAPONS ASSESSMENT (ACWA)
PROJECTILE WASHOUT STUDY**

**Mark A. Guelta
Laurie Fazekas-Carey**

RESEARCH AND TECHNOLOGY DIRECTORATE

December 2003

Approved for public release;
distribution is unlimited.



20040615 125

Disclaimer

The findings in this report are not to be construed as an official Department of the Army position unless so designated by other authorizing documents.

REPORT DOCUMENTATION PAGE

Form Approved
OMB No. 0704-0188

Public reporting burden for this collection of information is estimated to average 1 hour per response, including the time for reviewing instructions, searching existing data sources, gathering and maintaining the data needed, and completing and reviewing this collection of information. Send comments regarding this burden estimate or any other aspect of this collection of information, including suggestions for reducing this burden to Department of Defense, Washington Headquarters Services, Directorate for Information Operations and Reports (0704-0188), 1215 Jefferson Davis Highway, Suite 1204, Arlington, VA 22202-4302. Respondents should be aware that notwithstanding any other provision of law, no person shall be subject to any penalty for failing to comply with a collection of information if it does not display a currently valid OMB control number. **PLEASE DO NOT RETURN YOUR FORM TO THE ABOVE ADDRESS.**

1. REPORT DATE (DD-MM-YYYY) XX-12-2003		2. REPORT TYPE Final		3. DATES COVERED (From - To) Jan 2002 - Jun 2002			
4. TITLE AND SUBTITLE Biodegradation of Hydrolyzed Mustard from an Assembled Chemical Weapons Assessment (ACWA) Projectile Washout Study				5a. CONTRACT NUMBER			
				5b. GRANT NUMBER			
				5c. PROGRAM ELEMENT NUMBER 2R1A31			
6. AUTHOR(S) Guelta, Mark A.; and Fazekas-Carey, Laurie				5d. PROJECT NUMBER			
				5e. TASK NUMBER			
				5f. WORK UNIT NUMBER			
7. PERFORMING ORGANIZATION NAME(S) AND ADDRESS(ES) AND ADDRESS(ES) DIR, ECBC, ATTN: AMSRD-ECB-RT-BP, APG, MD 21010-5424				8. PERFORMING ORGANIZATION REPORT NUMBER ECBC-TR-291			
9. SPONSORING / MONITORING AGENCY NAME(S) AND ADDRESS(ES) PM, ACWA, ATTN: AMSCB-PM-ACWA, APG, MD 21010-5424				10. SPONSOR/MONITOR'S ACRONYM(S)			
				11. SPONSOR/MONITOR'S REPORT NUMBER(S)			
12. DISTRIBUTION / AVAILABILITY STATEMENT Approved for public release; distribution is unlimited.							
13. SUPPLEMENTARY NOTES							
14. ABSTRACT <p>Prior Demonstration (Demo) I and Engineering Design Study (EDS) I testing conducted by the PM, Assembled Chemical Weapons Assessment, validated biological treatment of a mixture of HD and tetrytol hydrolysates using Honeywell Immobilized Cell Bioreactor (ICB). The HD hydrolysate used in the previous tests was made from neat agent obtained from ton containers. Because the Pueblo Chemical Depot (PCD), Pueblo, CO, stockpile consists of assembled munitions that contain liquid agent and solid material (heel), the hydrolysate used in prior ICB testing was not fully representative of the hydrolysate that will be produced at Pueblo. Therefore, ICB testing using hydrolysate prepared with liquid agent and heel from actual munitions was planned and executed and is the subject of this report.</p> <p>The ability for a biological culture to degrade the hydrolyzed HD agent from a chemical was tested. The ability of the culture to degrade hydrolysate containing heel material representative of what can be expected from munitions washout was compared directly to performance of a bacterial culture degrading hydrolysate with no heel material. The study shows that hydrolyzed HD agent removed from a projectile washout study can be effectively degraded in a bioreactor system and that there was no effect from the hydrolyzed heel material during the 60-day steady-state period of the study. Performance of the laboratory scale ICB was comparable to earlier testing with the pilot-scale reactor.</p>							
15. SUBJECT TERMS <table style="width: 100%; border: none;"> <tr> <td style="width: 50%; border: none;">Immobilized cell bioreactor Assembled Chemical Weapons Assessment (ACWA) program</td> <td style="width: 50%; border: none;">HD hydrolysate Tetrytol hydrolysate</td> </tr> </table>						Immobilized cell bioreactor Assembled Chemical Weapons Assessment (ACWA) program	HD hydrolysate Tetrytol hydrolysate
Immobilized cell bioreactor Assembled Chemical Weapons Assessment (ACWA) program	HD hydrolysate Tetrytol hydrolysate						
16. SECURITY CLASSIFICATION OF:			17. LIMITATION OF ABSTRACT	18. NUMBER OF PAGES	19a. NAME OF RESPONSIBLE PERSON		
a. REPORT	b. ABSTRACT	c. THIS PAGE			Sandra J. Johnson		
U	U	U	UL	64	19b. TELEPHONE NUMBER (include area code) (410) 436-2914		

Blank

PREFACE

The work described in this report was authorized under Sales Order No. 2R1A31, Assembled Chemical Weapons Assessment (ACWA) Program. This work was started in January 2002 and completed in June 2002.

The use of either trade or manufacturers' names in this report does not constitute an official endorsement of any commercial products. This report may not be cited for purposes of advertisement.

This report has been approved for public release. Registered users should request additional copies from the Defense Technical Information Center; unregistered users should direct such requests to the National Technical Information Service.

Blank

CONTENTS

1.	INTRODUCTION	7	
2.	MATERIALS AND METHODS.....	8	
2.1	Test Materials.....	8	
2.1.1	HD Hydrolysate	8	
2.1.2	Tetrytol Hydrolysate	9	
2.1.3	Test Setup.....	9	
2.1.4	Feed Preparation	11	
2.1.5	Sampling and Analysis	12	
2.2	ICB Operating Schedule	13	
2.2.1	Start-up and Ramp-up.....	13	
2.2.2	Steady-State Operation	13	
3.	ANALYTICAL RESULTS AND DISCUSSIONS	13	
3.1	Chemical Oxygen Demand	14	
3.2	pH.....	16	
3.3	Nitrogen	17	
3.4	Phosphate	18	
3.5	Total Suspended Solids	18	
3.6	Volatile Suspended Solids	23	
3.7	Total Dissolved Solids	24	
3.8	Temperature	26	
3.9	Thiodiglycol	27	
3.10	Operational Issues	28	
4.	CONCLUSIONS.....	29	
4.1	Feed and Effluent Characterization.....	29	
4.2	Impact of HD Hydrolysate Solids	30	
4.3	Thiodiglycol (TDG) Destruction	30	
APPENDIXES			
A - SUMMARY OF PROCESS MONITORING ANALYSIS			
DURING 60-DAY STEADY-STATE PERIOD.....			35
B - RESULTS FROM CHARACTERIZATION OF TETRYTOL			
HYDROLYSATE			37
C - RESULTS OF TDG ANALYSIS DURING RAMP-UP PERIOD			39
D - THIODIGLYCOL CONCENTRATION IN FILTERED FEED ICB			
DURING 60-DAY STEADY-STATE OPERATION PERIOD			41
E - RESULTS OF TCLP ANALYSIS OF ICB SOLIDS			43
F - RESULTS OF METALS ANALYSIS FROM BIOFEED SAMPLES.....			45

G - RESULTS OF ANALYSIS FOR METALS IN THE ICB EFFLUENT COMPOSITE SAMPLES.....	47
H - EFFLUENT SAMPLES INCLUDING 3.8% HD WITH SOLIDS PARTIALLY SETTLED.....	49
I - SOLIDS DATA FOR ICB 1	51
J - SOLIDS DATA FOR ICB 2	53
K - HD HYDROLYSATE BREAKDOWN PRODUCTS	55
L - ICB EFFLUENT CHARACTERIZATION.....	57
M - ANALYSIS OF THE FEED SOLIDS	61
N - POSITIVE RESULTS FOR THE BIOFEED CHARACTERIZATION.....	63

FIGURES

1. ICB Setup.....	10
2. Feed Schedule for Cells 1A and 2A.....	14
3. COD Results for ICB 1 (Unfiltered Feed).....	15
4. COD Results for ICB 2 (Filtered Feed).....	15
5. COD Consumption for ICBs 1 and 2.....	16
6. Ammonia-Nitrogen Results for ICB 1 (Unfiltered).....	17
7. Ammonia-Nitrogen Results for ICB 2 (Filtered).....	18
8. TSS and VSS Results for ICB 1 Feed (Unfiltered).....	19
9. TSS and VSS Results for ICB 1 Effluent (Unfiltered).....	20
10. TSS and VSS Results for ICB 2 Feed (Filtered).....	20
11. TSS and VSS Results for ICB 2 Effluent (Filtered).....	21
12. TDS Results for ICB 1	24
13. TDS Results for ICB 2.....	25

TABLES

1. HD Hydrolysate Characterization.....	8
2. Tetrytol Hydrolysate Characterization.....	9
3. ICB Feed Recipe	11
4. Wolin Salts Recipe.....	11
5. pH Results.....	17
6. Statistical Comparisons of the ICB Biofeed TSS Values	21
7. Statistical Comparisons of the ICB Effluent TSS Values.....	22
8. Summary of the ICB 1 TSS and VSS Analyses	23
9. Summary of the ICB 2 TSS and VSS Analyses	23
10. Results of the Student t-test for TSs in ICB 1 and 2 Biofeeds.....	25
11. Results of the Student t-test for TSs in ICB 1 and 2 Effluents	26
12. Summary of TDG Results from Steady-State Operation.....	27
13. TDG Results in PWS ICBs Versus Demo I and EDS ICB.....	27
14. Results of Statistical Analysis of TDG Concentrations in the ICB Biofeeds.....	31
15. Results of Statistical Analysis of TDG Concentrations in the ICB Effluents.....	31
16. Comparison of COD and TDG Consumption Between the Laboratory and Pilot Scale ICBs	32

**BIODEGRADATION OF HYDROLYZED MUSTARD
FROM AN ASSEMBLED CHEMICAL WEAPONS ASSESSMENT (ACWA)
PROJECTILE WASHOUT STUDY**

1. INTRODUCTION

Prior Demonstration¹ (Demo) I and Engineering Design Study (EDS) I testing conducted by PM, Assembled Chemical Weapons Assessment (ACWA), validated biological treatment of a mixture of HD and tetrytol hydrolysates using the Honeywell Immobilized Cell Bioreactor (ICB). The HD hydrolysate used in the previous tests was made from neat agent obtained from ton containers. Because the Pueblo Chemical Depot (PCD), Pueblo, CO, stockpile consists of assembled munitions containing liquid agent and solid material (heel), the hydrolysate used in prior ICB testing was not fully representative of the hydrolysate that will be produced at Pueblo. Therefore, ICB testing using hydrolysate prepared with liquid agent and heel from actual munitions was planned, executed, and is the subject of this report.

Parsons/Honeywell (Des Plaines, IL) conducted EDS testing on a projectile washout system (PWS) on actual 4.2-in. HD mortars from the stockpile at Deseret Chemical Activity, (Deseret, UT). These are the same type of mortars that make-up a large portion of the Pueblo stockpiles. Results of the PWS testing indicate that these munitions contain a significant amount of heel in the agent cavity. On average, 16% of the HD in the test munitions had solidified. In the PWS testing, the heel was washed out of the munitions and combined with liquid agent drained from the munitions. The combined streams were then neutralized, and the resulting HD hydrolysate was used in this laboratory-scale ICB study.

The specific objectives of this test follow:

- Confirm the ability of the laboratory-scale ICBs to effectively treat the PWS-generated HD hydrolysate at the hydraulic residence time (HRT) that represents full-scale design.
- Assess the impact of suspended solids in HD hydrolysate on ICB performance.
- Confirm the ability of the laboratory-scale ICBs to eliminate thiodiglycol (TDG) in the HD hydrolysate.
- Characterize ICB effluents.

¹ Guelta, M.A.; Chester, N.A.; Lupton, F.S.; Koch, M.; Fry, I.J.; Kim, M.H. *Biodegradation of HD and Tetrytol Hydrolysates in a Pilot Scale Immobilized Cell Bioreactor*; ECBC-TR-192; U.S. Army Edgewood Chemical Biological Center: Aberdeen Proving Ground, MD, 2001; UNCLASSIFIED Report (AD-A396 602).

2. MATERIALS AND METHODS

2.1 Test Materials.

2.1.1 HD Hydrolysate.

The HD hydrolysate used for this test was produced from the water hydrolysis of drained agent and heel from 4.2-in. HD mortars as part of the PWS study. The hydrolysate was produced at a nominal HD loading of 3.8 wt%. The HD hydrolysate batch, used in this test, number PBHY25D02BX, was characterized for major constituents (Table 1).

Table 1. HD Hydrolysate Characterization

Constituent	Concentration (mg/L)
Thiodiglycol (TDG)	17,537
Dithane	2,093
Thiox	47.9
Chemical oxygen demand (COD)	43,100
Total Organic Carbon (TOC)	8,120
% TOC as TDG	84.9%
COD:TOC ratio	5.31
Sulfate	84
Sulfur	6,010
Total dissolved solids (TDS)	28,000
Total suspended solids (TSS)	1,000
pH	13.0
Specific gravity (g/mL)	1.03
Aluminum	1.99
Arsenic	0.579
Barium	0.033
Cadmium	3.2
Calcium	10.9
Chloride	10,800
Copper	0.281
Iron	520
Lead	3.69
Magnesium	5.74
Mercury	0.013
Molybdenum	0.065
Nickel	0.330
Phosphorus	0.456
Potassium	15.2
Silver	5.73
Sodium	10,630
Zinc	3.59

2.1.2 Tetrytol Hydrolysate.

Tetrytol hydrolysate was prepared at the U.S. Army Edgewood Chemical Biological Center (ECBC) for this test by caustic hydrolysis of tetrytol at a nominal tetrytol loading of 6.67% (wt/vol). Samples of the tetrytol hydrolysate were analyzed for energetics, metals, mercury, anions, volatile organic compounds (VOCs), and semivolatile organic compounds (SVOCs). The energetics and breakdown products were of principle interest. None of the energetics were detected in the hydrolyzed samples. Analysis for energetics was difficult due to interferences in the sample matrix. The tetrytol hydrolysate was analyzed for major constituents of the tetrytol. Results of this analysis are shown in Table 2. Complete tetrytol hydrolysate characterization results are provided in the Appendixes.

Table 2. Tetrytol Hydrolysate Characterization

Compound	Result (µg/L)	Qualifier
1,3,5-Trinitrobenzene	2800	UI
1,3-Dinitrobenzene	2800	UI
2,4,6-Trinitrotoluene	2500	UI
2,4-Dinitrotoluene	2500	UI
2,6-Dinitrotoluene	2500	UI
2-Amino-4, 6-dinitrotoluene	2500	UI
2-Nitrotoluene	2500	UI
3-Nitrotoluene	2500	UI
4-Amino-2, 6-dinitrotoluene	2500	UI
4-Nitrotoluene	120000	UI
High melting explosive (HMX)	3200	UI
Nitrobenzene	28000	UI
Royal demolition explosive (RDX, 1,3,5-trinitro-1, 3, 5-triazine)	2500	UI
Tetryl	2500	UI

UI = Analyte was not detected; the reporting limit was raised due to interference in the sample.

Result listed with a qualifier of UI is the sample detection limit.

2.1.3 Test Setup.

The ICB setup is represented in Figure 1. Two ICBs were used for this test. One received feed with unfiltered HD hydrolysate, and the other received feed with filtered HD hydrolysate. Each ICB consisted of two glass columns (Cells A and B). The working volume of each cell was 630 mL (nominal) before biomass loading. The two cells of each ICB were operated in series to closely resemble the configuration of the previously demonstrated multi-celled 1000-gal pilot-scale ICB. Three Applikon Bioprocess Controllers [(biocontrollers)/ Applikon Biotechnology, Clinton, NJ] monitored and controlled the automated portions of the ICB operation. This study included the following automated operations:

- **Feed schedule:** The ICB feed was pumped from a 1-L reservoir into the first ICB in the series. The feed pump operated at a fixed speed. An automated timer controlled feed to the reactor by turning the pump on at specific intervals. To maintain a 5-day HRT (252 mL/day), the pump was set to operate using masterflex size 16 tubing 0.82% of the time.

- **pH control:** The pH was controlled in only an upward direction since the breakdown and consumption of TDG, the primary organic constituent of HD hydrolysate, produces an acid. The pH was controlled by adding a 0.9M sodium bicarbonate solution.

- **Effluent removal:** An effluent pump operating on timed intervals pumped effluent from Cell B to the effluent reservoir. Effluent was allowed to accumulate in the reservoir between sampling events. After each effluent sampling event, the effluent was placed in a composite sample reservoir until needed.

A diaphragm pump supplied air through a glass frit in the bottom of Cell A. Air and effluent from Cell A overflowed into Cell B through a large tygon tube. Air was exhausted from Cell B into the facility hood system.

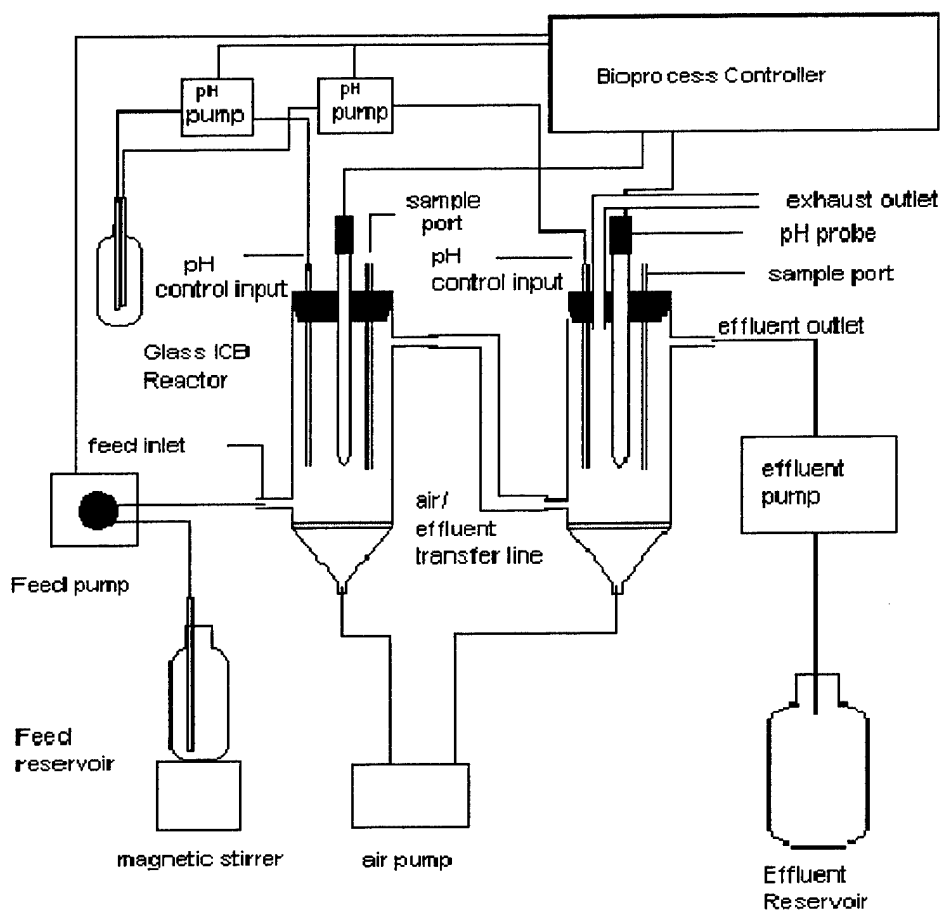

Figure 1. ICB Setup

2.1.4 Feed Preparation.

Before preparing the feed, the 20-L hydrolysate container was shaken vigorously for 5 min to suspend the hydrolysate undissolved solids. A portion of the HD hydrolysate was removed immediately after shaking and directly used in the preparation of the unfiltered feed (ICB 1). For the filtered feed (ICB 2), HD hydrolysate was poured into a 1-L glass bottle, and the solids were allowed to settle for 48 hr. The supernatant was poured into 500-mL bottles and centrifuged at 9500 rpm for 15 min. The clarified hydrolysate was then used to make the filtered feed. The unfiltered and filtered ICB feeds were prepared in 4-L batches using the recipe shown in Table 3.

Table 3. ICB Feed Recipe (per 1 L of feed)

Item	Quantity	Unit
HD hydrolysate (3.8 wt%)	300	mL
Tetrytol hydrolysate (6.67 wt/vol%)	14	mL
NH ₄ Cl	0.825	G
Mono potassium phosphate (KPO ₃)	0.15	G
Sulfur-free Wolin Salts	10	mL
Tap water to volume	~3676	mL
Final volume	1000	mL

The test plan originally called for the HD hydrolysate to be either centrifuged or filtered directly to make the filtered feed. Initial attempts to centrifuge the HD hydrolysate failed; the solids did not form a pill as expected at centrifuge rate of 9500 rpms. In fact, the solids coated the walls of the centrifuge containers. The solids had to be scraped and washed from the containers. This action was viewed as compromising any analysis that would follow. Attempts at filtration were also ineffective since the solids were small enough to pass through standard glass filter paper. Alternatively, settling the solids and pouring off the supernatant separated the suspended solids for feed preparation. Sulfur-free Wolin salts were added to the feed to supply necessary micronutrients. The ingredients for sulfur-free Wolin salts are listed in Table 4.

Table 4. Wolin Salts Recipe

Compound	Wt Per Liter (gm)
Nitrilotriacetic acid	3.00
NaOH	Enough to allow Nitrilotriacetic acid to dissolve
MgCl ₂ 4H ₂ O	6.95
MnCl ₂	0.66
FeCl ₂	0.23
CaCl ₂ 2H ₂ O	0.07
CoCl ₂ 6H ₂ O	0.10
ZnCl ₂	0.06
H ₃ BO ₃	0.02
Na ₂ MoO ₄ 2H ₂ O	0.01
CuCl ₂ 2H ₂ O	0.01

2.1.5 Sampling and Analysis.

Sampling of the ICB feeds, contents, and effluents occurred in two stages. The first stage was the ramp-up period in which only in-house process monitoring parameters were measured. In-house measurements included bench-top analysis for chemical characteristics using a Hach 5 kit. Standard methods² for wastewater analysis were used for measuring feed and effluent solids. In-house process monitoring included the following analyses:

- COD, Hach Method 8000, reactor digestion method
- Ammonia (NH₃), Hach Method 10030, salicylate method (NH₃-N)
- Phosphate (PO₄), Hach Method 8178 (orthophosphate), amino acid method
- Total suspended solids (TSS), Method 2540 D²
- Volatile suspended solids (VSS), Method 2540 E²
- Total dissolved solids (TDS), Method 2540 C

Process monitoring sampling occurred frequently during ramp-up because of a need to closely monitor the biomass response to frequent changes in ICB feed strength. Chemical oxygen demand (COD) was one of the more important monitoring parameters since it is the easiest method for measuring the concentration of organic compounds. COD is a good and quick indicator of feed consumption and excess food accumulation within the ICB.

Also during ramp-up, ECBC analyzed feed and clarified effluent samples for TDG. Feed sample (50 µL) and clarified effluent samples (100 µL) were placed in 1.5-mL GC vials, dried, and then derivatized with 250 µL of 1% TCMS in BSTFA. The samples were incubated at 100 °C for 30 min. After cooling, the samples were brought to volume with 750 µL acetonitrile. The sample (1 µL) was injected, split 10:1 into an HP 5890 with a 0.32-mm x 30-m HP-5 column (Hewlett Packard, Houston, TX) with the Flame Photometric Detector (FPD) in sulfur mode. G.C. standard curves were made from neat TDG purchased (Cat No. 103039, Lot No. 4903E) January 2002 from ICN Biomedicals, Incorporated (Aurora, OH).

Steady-state sampling occurred after the ramp-up period was completed. The steady-state period started when the ICB feed reached the test design strength of 300 mL HD hydrolysate per liter of feed at a 5-day HRT. Steady-state sampling included the process monitoring analyses mentioned above as well as additional feed and effluent characterization analyses, which included the following parameters:

- VOC
- SVOC
- TDG
- Metals and mercury
- Anions
- Toxicity characteristics leaching procedure (TCLP) analysis of solids

² *Standard Methods for the Examination of Water and Wastewater*, APHA, 18th ed. American Public Health Association: Washington DC, 1992.

All effluent and feed characterization conducted during the steady-state period were performed by outside contract laboratories except for TDG, which was analyzed by the ECBC Analytical Chemistry Team (ACT).

During ramp-up, process monitoring was done on an as needed basis. COD was usually measured several times per week to closely monitor culture response to feed adjustments. During steady state, process monitoring and characterization sampling was done on a schedule based on the ICB feed batch. The ICB feed and effluents from Cells 1A and 2A were characterized two times per batch. Effluents from Cells 1B and 2B were characterized four times per feed batch. These characterization samples were grab samples. Grab samples were taken to represent conditions and constituents in either the feeds or effluents at the time of the sampling. Three composite samples of the effluents were also taken during steady state. The effluents from ICBs 1 and 2 were collected into separate 4-L amber bottles until the end of a feed batch. A sample of the composite effluent for each ICB collected over the course of one batch was then characterized. Three composite samples were collected for each ICB during the steady-state period. Lastly, a composite of the solids removed from the HD hydrolysate used to prepare the feed for ICB 2 was collected for analysis.

2.2 ICB Operating Schedule.

2.2.1 Start-up and Ramp-up.

Activated sludge was collected from the Back River Wastewater Treatment Plant (Baltimore, MD) on 22 January 2002 and aerated overnight. On 23 January, the ICBs were each inoculated with 315 mL of tap water and 32 mL of activated sludge. The ICBs were filled to only ½ capacity to leave headroom for foaming that frequently occurs on start-up. On the first day, 31.5 mLs of feed were added to each of the ICBs. The ICBs were fed in batch mode for the first week. On Day 10, the ICBs were filled to their working volume and placed in continuous feed mode. Once in continuous feed mode, the feed strength was ramped-up to the design loading. On Days 38 and 42, over-feeding of ICB 1 caused two interruptions in the feed schedule, causing a set back in the ramp-up schedule.

2.2.2 Steady-State Operation.

The 60-day steady-state period began on Day 59 when the biomass was able to consume the COD at the design feed strength. The feed schedule is shown in Figure 2. Feed rate is represented as milligrams of COD given to reactor 1A and 2A per day.

3. ANALYTICAL RESULTS AND DISCUSSIONS

Samples taken for process monitoring were analyzed in-house. Thiodiglycol analyses discussed in Section 3.9 are the only data in this section that were not process monitoring samples.

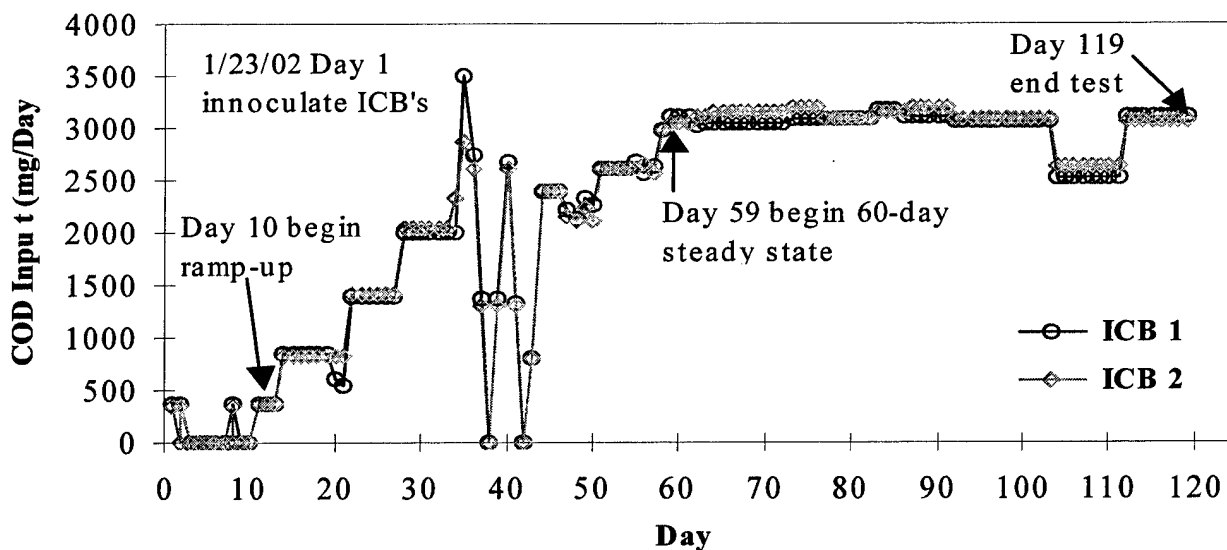

Figure 2. Feed Schedule for Cells 1A and 2A

3.1 Chemical Oxygen Demand.

COD, a measure of the chemically oxidizable compounds in an aqueous sample, was one of the major process parameters used to measure the overall system effectiveness in treating the combined HD/tetrytol hydrolysates. The TDG and other organic hydrolysis products are major sources of COD in the feed. Because COD analysis is inexpensive, has a quick turn-around time, and can be performed as a process monitoring sample, it was used as a primary indicator of the biomass health and performance throughout the test. The TDG analysis of steady-state samples was also performed, and the results are presented later in this report.

After the initial batch operating period, the initial feed strength in continuous mode was 1/8th the design strength. The feed strength was adjusted as the biomass grew and became acclimated to the feed, as indicated by COD removal. The feed strength was ramped-up in response to COD removal. The COD concentration was routinely measured in the feed, in Cell A, and in the effluent of each ICB. COD removal efficiency was calculated as follows:

$$\text{COD}_{\text{REMOVAL EFF, \%}} = [(\text{COD}_{\text{input (mg/day)}} - \text{COD}_{\text{output (mg/day)}}) / \text{COD}_{\text{input (mg/day)}}] * 100 \quad (1)$$

Generally, a COD removal efficiency > 85% on a consistent basis indicates that the culture is ready for an increase in feed strength. However, it is also important to monitor COD levels in all cells of the ICB. There is a threshold concentration above which the organics in a feed can become inhibitory to the biomass. That level has not been well established for the hydrolysate feed. In past experience with the pilot-scale reactor, the COD in the first cell was generally below 4000 mg/L. This level became a benchmark for possible signs of trouble early in this laboratory-scale test. During ramp-up, the feed was stopped on occasion due to higher than expected COD levels in Cell 1A. Later in the test, the COD was allowed to increase to above 5000 mg/L with no apparent detrimental effects on the overall COD removal efficiency of the ICB.

During the ramp-up phase, the strength of the ICB feed was adjusted by diluting the full-strength feed with tap water. The feed COD and COD removal efficiency for the unfiltered and filtered feed ICBs are represented in Figures 3 and 4, respectively.

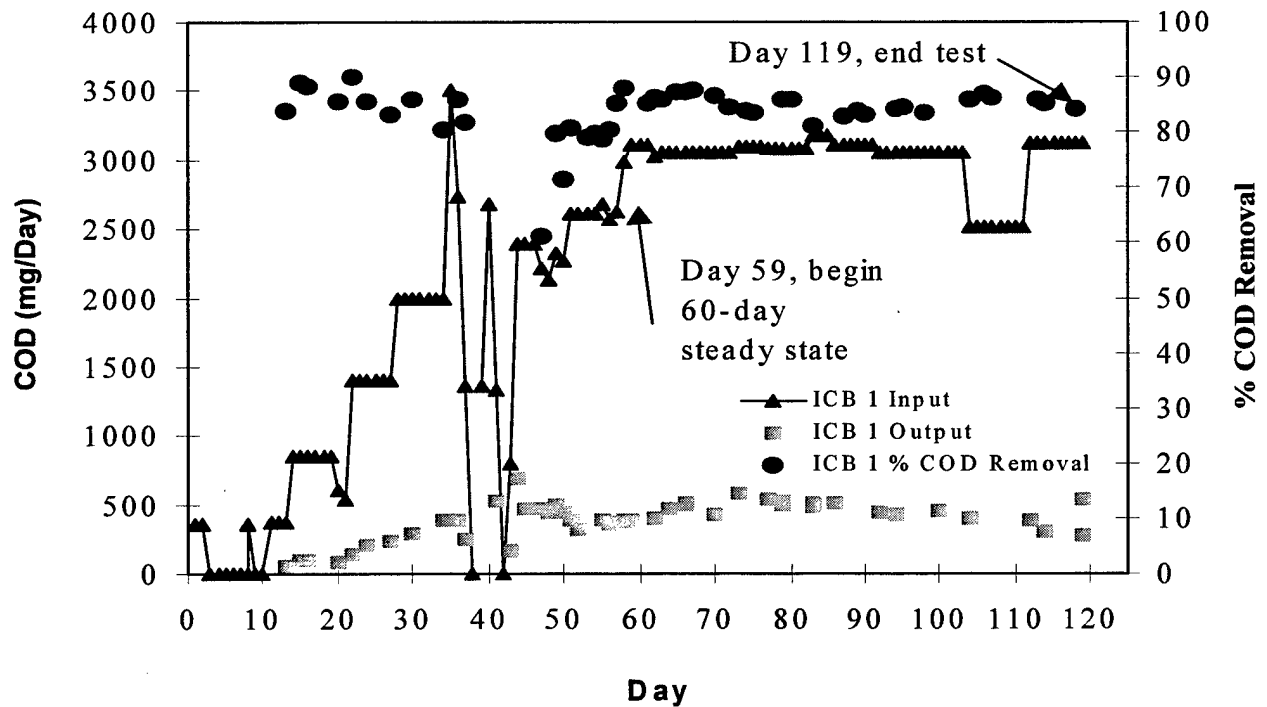

Figure 3. COD Results for ICB 1 (Unfiltered Feed)

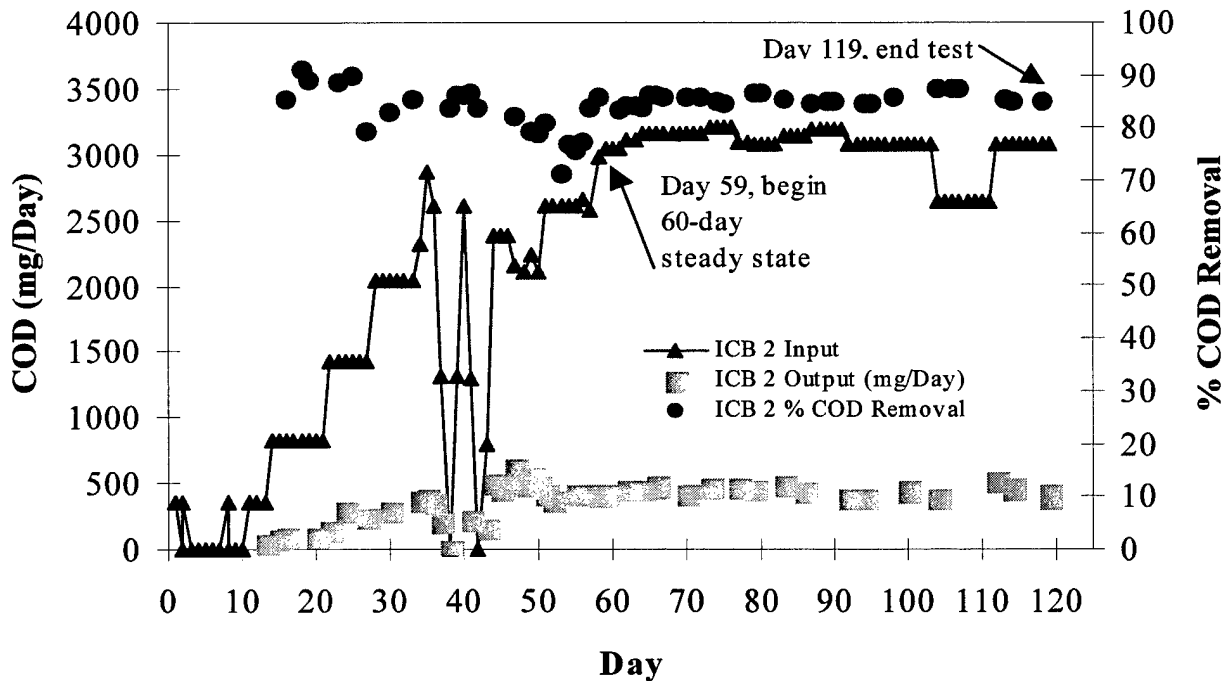

Figure 4. COD Results for ICB 2 (Filtered Feed)

The quantities of COD removed, or consumed, in the ICBs per unit volume of ICB were also calculated. COD consumption is calculated as follows:

$$\text{COD consumption} = \text{COD}_{\text{input (mg/day)}} - \text{COD}_{\text{output (mg/day)}} \quad (2)$$

These results are useful for comparison to previous studies using reactors of different size and type. The values calculated from the outfall for ICBs 1 and 2 are presented in Figure 5. No difference in consumption between the unfiltered and filtered feed is apparent. During the ramp-up period, consumption dropped on occasions when the feed was stopped due to elevated COD in one cell or another type of upset.

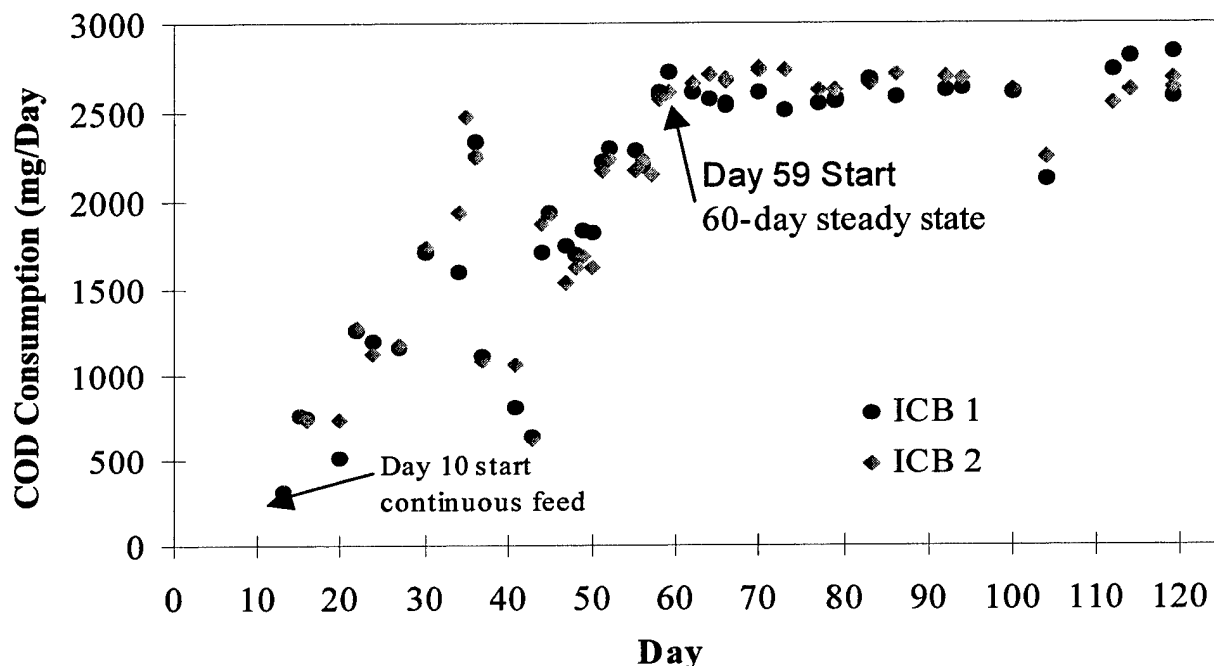

Figure 5. COD Consumption for ICBs 1 and 2

3.2 pH.

The pH in each cell of the ICBs was controlled through the biocontrollers. The pH of each reactor was set to 7.5 and maintained with 0.9N sodium bicarbonate solution. The pH readings were monitored daily and recorded during ramp-up and steady state sampling events. The pH readings of all feeds and ICB cells were fairly stable and "trendless." The statistics for the pH readings of each cell of the reactors are listed in Table 5.

Table 5. pH Results

	ICB 1 (unfiltered)			ICB 2 (filtered)		
	1 Feed	Cell 1A	Cell 1B	2 Feed	Cell 2A	Cell 2B
Mean	10.78	7.39	6.99	10.69	7.53	7.07
Minimum	9.00	7.06	6.49	9.26	7.20	6.50
Maximum	11.67	7.85	7.34	11.62	8.08	7.80
Std-D	0.94	0.22	0.19	0.73	0.23	0.32

3.3 Nitrogen.

Nitrogen levels in the feed and reactors were measured as nitrogen-ammonia. The nitrogen-ammonia concentrations in each ICB were measured using the Hach sample analysis kits. Initially, during ramp-up, ammonium bicarbonate served as the nitrogen source in the feed. However, this form of ammonia was difficult to detect in the feed and was soon changed to ammonium chloride (NH₄Cl). Feed and effluent nitrogen-ammonia levels were monitored during the ramp-up period and during sampling events throughout the steady-state period. Nitrogen-ammonia levels were originally low in the ICBs until ammonium chloride was added to the feed. Then, levels were elevated until the precise amount required in the feed was determined. Throughout the test, measured nitrogen-ammonia levels in the feed were erratic, perhaps due to interferences in the feed. The ammonia-nitrogen levels in the reactors are presented in Figures 6 and 7.

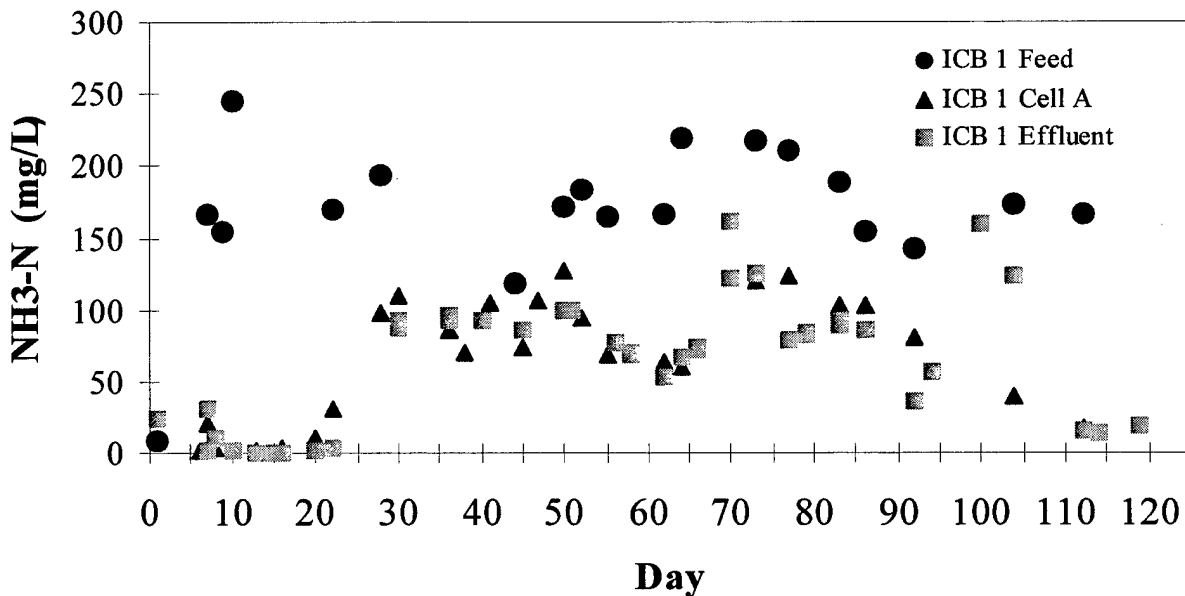

Figure 6. Ammonia-Nitrogen Results for ICB 1 (Unfiltered)

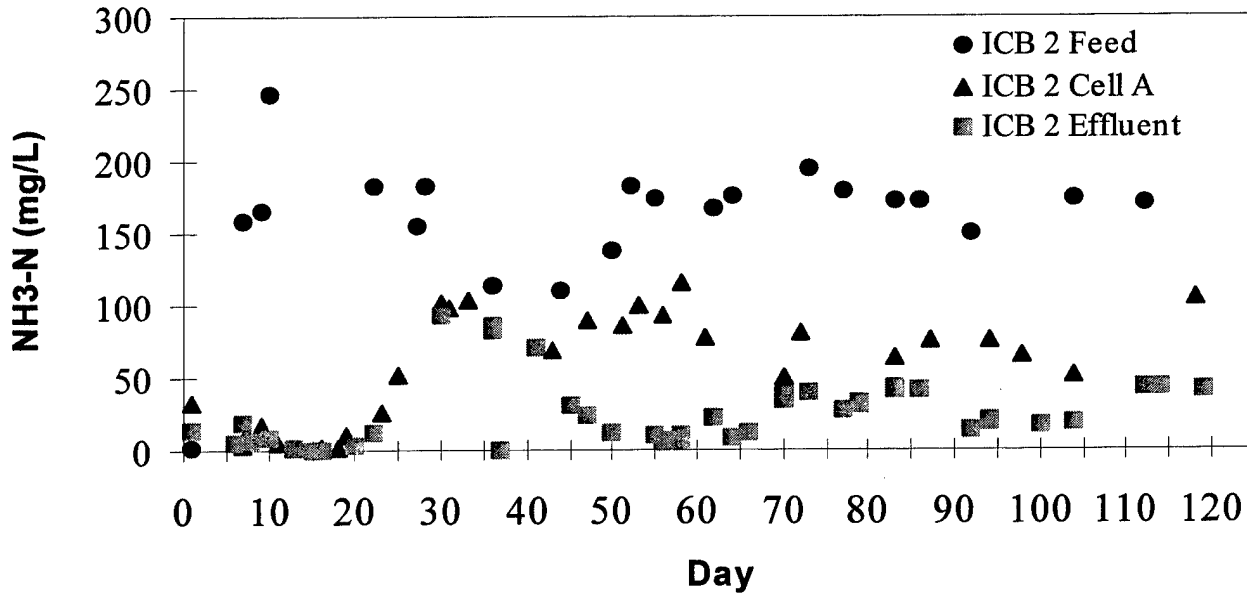

Figure 7. Ammonia-Nitrogen Results for ICB 2 (Filtered)

3.4 Phosphate.

Phosphate is a nutrient added to the feed as potassium phosphate to support biomass growth and health. Concentrations in the feed and effluents were fairly stable and “trendless” throughout the study. Potassium phosphate added to the feed at 0.16 g/L was kept constant throughout the test.

3.5 Total Suspended Solids.

Total suspended solids are a measure of the amount of filterable material, organic and inorganic, present in an aqueous sample. The TSS is important for measuring the health of a bioreactor system and for determining types and amounts of downstream treatment that may be required. It would be somewhat easier to recycle effluent from a system that generates less effluent TSS than from one that generates and discharges large amounts of solids. Since the biomass in an ICB grows on a support, it tends to generate less TSS than a Sequencing Batching Reactor (SBR). When cells either attached to or caught up in the support matrix die, they can be consumed in place by other members of the microbial consortium. In addition, the support matrix acts as a filter to retain some of the free-floating microbes.

Occasionally, biomass will slough off of the support material, even in a healthy system. Therefore, a one time per week measurement may not be very representative of the ICB TSS. A system that is stressed may slough large amounts of material suddenly. A sudden increase in TSS within the ICB effluent may indicate a problem within the system. There was an increase in TSS in ICB 1 effluent after the effluent transfer line from Cell A to Cell B became clogged overnight. Head-pressure within the system was enough to overcome the air supply pump, so aeration to Cell 1A was off for an undetermined period of time. An increase in ICB 1 effluent TSS was noted on Day 80 of the study.

There are also inorganic suspended solids in the feed stream, most notably precipitated iron that may not be degradable and could contribute directly to the ICB TSS. Measurement of biofeed was made particularly difficult due to the inclusion of the hydrolyzed heel. The heel in hydrolyzed form is a very fine particulate that passes through a standard glass filter sheet used as a standard for the TSS test. Therefore, a portion of the biofeed heel material is reported as TSS, and a portion is reported as TDS.

During the ramp-up portion of the test, the heel material affected the TSS measurements of the biofeed, causing several elevated readings. The heel material clogged the sintered glass filter support, greatly increasing filtering time and filter efficiency. Frequent washings of the filter and cindered glass alleviated this effect. This frequent washing procedure was adopted during ramp-up and did not affect data points during the steady-state period.

The passage of heel material and clogging of the sintered glass support was not observed in the ICB effluent samples. The TSS/VSS for the biofeed and effluent streams of the two reactors are represented in Figures 8 through 11.

After filtering a portion of the effluent in each sample, the efficiency of the filter would increase, trapping more of the heel material. In addition, complications resulted when the effluent samples also contained biomass that further clogged the filter. Finally, the support stand for the vacuum filtration stand is a sintered glass material that also became clogged with the hydrolyzed heel particulate. The TSS/VSS sample filtration process was modified to alleviate clogging problems. Small aliquots of effluent were used in combination with frequent rinsings to minimize support and filter clogging. In any case, a majority of the heel particulate passed through the glass filter. Initially, the problem was unnoticed until variability was observed in the feed sample data. The TSS/VSS for feed and effluent streams of the two reactors are represented in Figures 8 through 11.

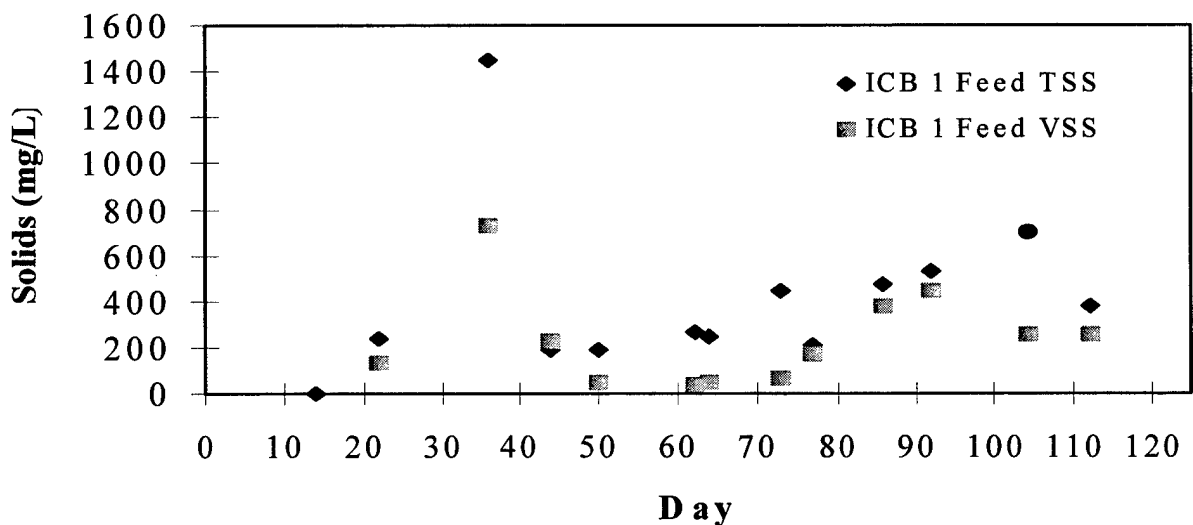

Figure 8. TSS and VSS Results for ICB 1 Feed (Unfiltered)

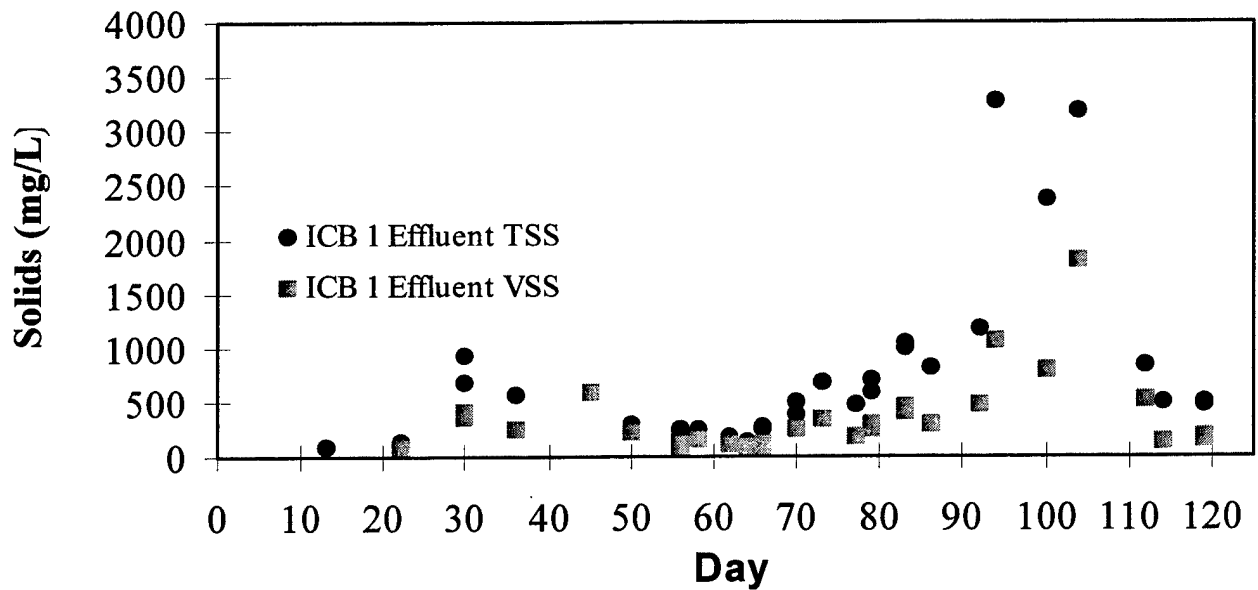

Figure 9. TSS and VSS Results for ICB 1 Effluent (Unfiltered)

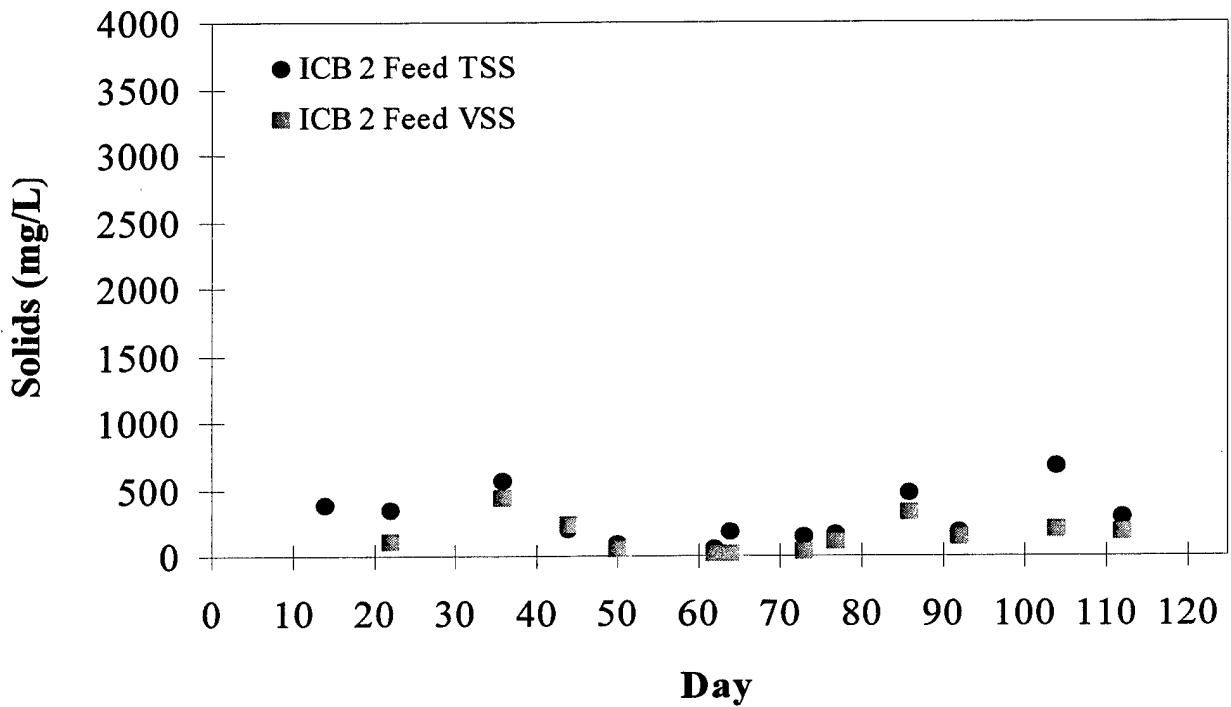

Figure 10. TSS and VSS Results for ICB 2 Feed (Filtered)

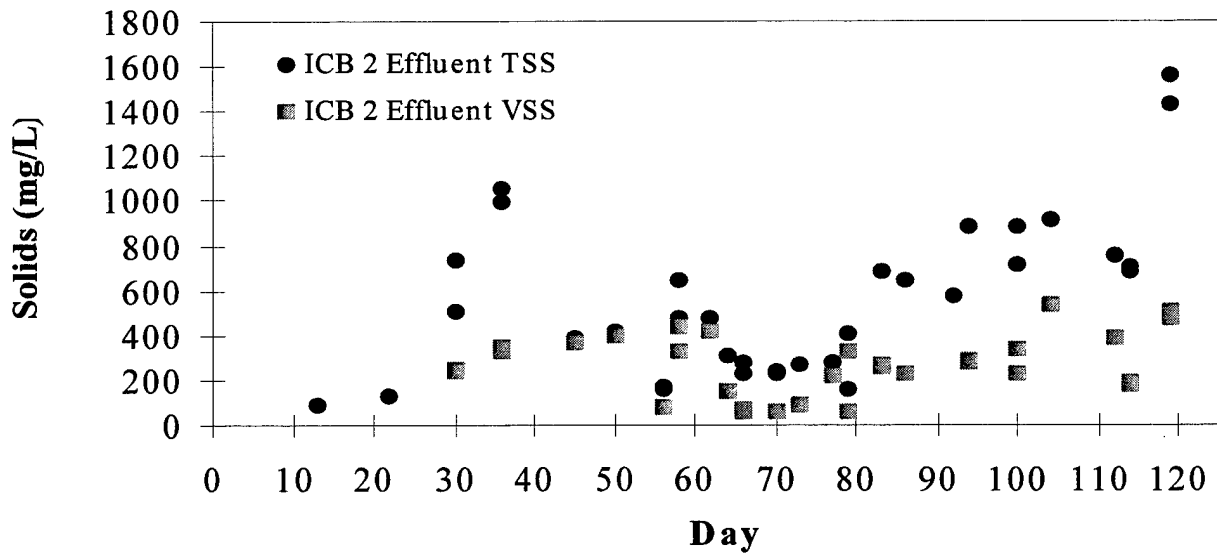

Figure 11. TSS and VSS Results for ICB 2 Effluent (Filtered)

Results of combined TSS data from the 60-day steady-state operation period were analyzed using the student t-test to determine any statistical differences between input and output solids' concentrations from the ICBs. Data in Table 6 compares the values of TSS in the biofeed measured on scheduled sampling events during the 60-day steady-state period.

Table 6. Statistical Comparisons of the ICB Biofeed TSS Values

ICB1 Biofeed TSS (mg/L)	ICB 2 Biofeed TSS (mg/L)	t-Test: Paired Two Sample for Means	Variable 1	Variable 2
262.00	59.10	Mean	405.94	272.07
249.14	177.60	STD Error	58.69	72.63
444.67	150.89	Observations	8.00	8.00
207.70	157.43	Hypothesized Mean Difference	0.00	
472.00	466.40	df	7.00	
530.00	184.80	t Stat	2.91	
700.00	681.00	P Stat (T<=t) one-tail	0.01	
382.00	299.33	t Critical one-tail	1.89	
		P Stat (T<=t) two-tail	0.02	
		t Critical two-tail	2.36	

A p-stat value >0.05 indicates no significant statistical difference between the variables at the 95% confidence level. The student t-test indicates a significant difference between the TSS values measured in the biofeed between ICBs 1 and 2, at the 95% confidence level. The TSS values were significantly higher in ICB 1 biofeed than they were in ICB 2 biofeed.

ICB effluent TSS values were also analyzed using the student t-test for any significant statistical difference between TSS values in the ICB effluents. This data is presented in Table 7.

Table 7. Statistical Comparisons of the ICB Effluent TSS Values

ICB 1 Effluent TSS (mg/L)	ICB 2 Effluent TSS (mg/L)	t-Test: Paired Two Sample for Means	Variable ICB 1	Variable ICB 2
174.17	477.43	Mean	728.588	620.05
134.31	310.57	STD Error	121.95	74.70
252.00	275.55	Observations	21.00	24.00
262.00	232.89	Hypothesized Mean Difference	0.00	
383.11	240.66	df	43.00	
506.67	228.22	t Stat	0.76	
675.78	265.11	P stat (T<=t) one-tail	0.44	
479.71	273.50	t Critical one-tail	0.78	
694.00	404.57			
598.00	158.40			
1046.67	688.33			
995.29	684.00			
807.20	644.00			
1177.20	576.00			
1983.00	883.00			
2367.00	886.00			
830.33	718.00			
456.67	884.00			
501.23	916.00			
473.00	751.33			
503.00	688.00			
	702.40			
	1563.20			
	1430.00			

A p-stat value of >0.05 indicates no significant statistical difference between the variables at the 95% confidence level. The student t-test indicates there is no significant difference in TSS in the output from ICBs 1 and 2 at the 95% confidence level. During the analysis, three data points identified as outliers from ICB 1 were eliminated. These outliers coincide with a minor upset that occurred when the transfer line from ICB 1 Cell 1 to Cell 2 became clogged after stirring the cultures.

3.6

Volatile Suspended Solids.

Volatile suspended solids (VSS) are materials that are undissolved and captured on the standard glass filter sheet. The VSS is the portion of the TSS that can be volatilized at 500°C and normally represents the organic portion of the TSS. Since the VSS is a subsample of the TSS, it should never exceed the TSS. But, it often tracks the TSS unless there is a significant change in the process that changes the TSS/VSS ratio. After baking the sample in a muffle furnace at 500°C, the portion that remains is the inorganic portion of the suspended solids. The VSS are represented in Figures 8 through 11 with the TSS. A statistical summary of the solids' data is presented in Tables 8 and 9. The ratio of TSS to VSS values was calculated for each sample event. Ratios plotted versus date were shown to be "trendless." Full solids' results are presented in the appendixes.

Table 8. Summary of the ICB 1 TSS and VSS Analyses

Parameter	Feed TSS	Feed VSS	Cell 1a TSS	Cell 1a VSS	Effluent TSS	Effluent VSS
	(mg/L)	(mg/L)	(mg/L)	(mg/L)	(mg/L)	(mg/L)
Mean	405.94	207.60	588.58	212.95	1062.53	417.28
Min	207.70	41.20	174.60	87.40	134.31	85.11
Max	700.00	444.00	1467.00	339.00	3734.30	1803.00
Std-D	166.00	152.98	434.39	97.42	1045.73	409.27
Count	11.00	11.00	12.00	12.00	34.00	33.00

ICB 1 Feed Ratio of TSS: VSS = 2:1
 ICB 1 Cell 1a Ratio TSS: VSS = 2.8:1
 ICB 1 Effluent Ratio TSS: VSS = 2.55:1

Table 9. Summary of ICB 2 TSS and VSS Analyses

Parameter	Feed TSS	Feed VSS	Cell 2a TSS	Cell 2a VSS	Cell 2a TSS	Cell 2a VSS
	(mg/L)	(mg/L)	(mg/L)	(mg/L)	(mg/L)	(mg/L)
Mean	272.1	130.1	398.1	207.6	620.0	247.4
Min	59.1	21.7	161.8	31.1	158.4	58.9
Max	681.0	320.4	797.0	485.6	1563.2	541.0
Std-D	205.4	102.7	236.6	165.8	365.9	149.2
Count	11.0	11.0	12.0	11.0	34.0	31.0

ICB 2 Feed Ratio of TSS: VSS = 2.1:1
 ICB 2 Cell 2a Ratio TSS: VSS = 1.9:1
 ICB 2 Effluent Ratio TSS: VSS = 2.5:1

3.7

Total Dissolved Solids.

Total dissolved solids are the elements that can be dissolved in the aqueous portion of either the feed or the effluent. These dissolved elements are normally at a concentration that allows them to stay in solution. Changes in the solution chemistry can cause changes in the TDS. As elements become consumed, others may be either generated or added as nutrients or salts to control pH.

The TDS data for the ICBs are presented in Figures 12 and 13. The TDS levels in the ICB started low and trended upward as the feed concentration increased. The TDS also was lower in the feed than in the ICB effluents. The addition of sodium bicarbonate solution for pH control will cause an increase in dissolved solids as well as liquid loss due to evaporation. Net evaporative loss was low at 10 mL/day. The undissolved heel particulate complicated TDS measurement. The particulate was able to pass through a standard glass filter. In this case, the TDS data does not truly represent dissolved solids. Instead, this data represents dissolved solids and very fine undissolved particulate.

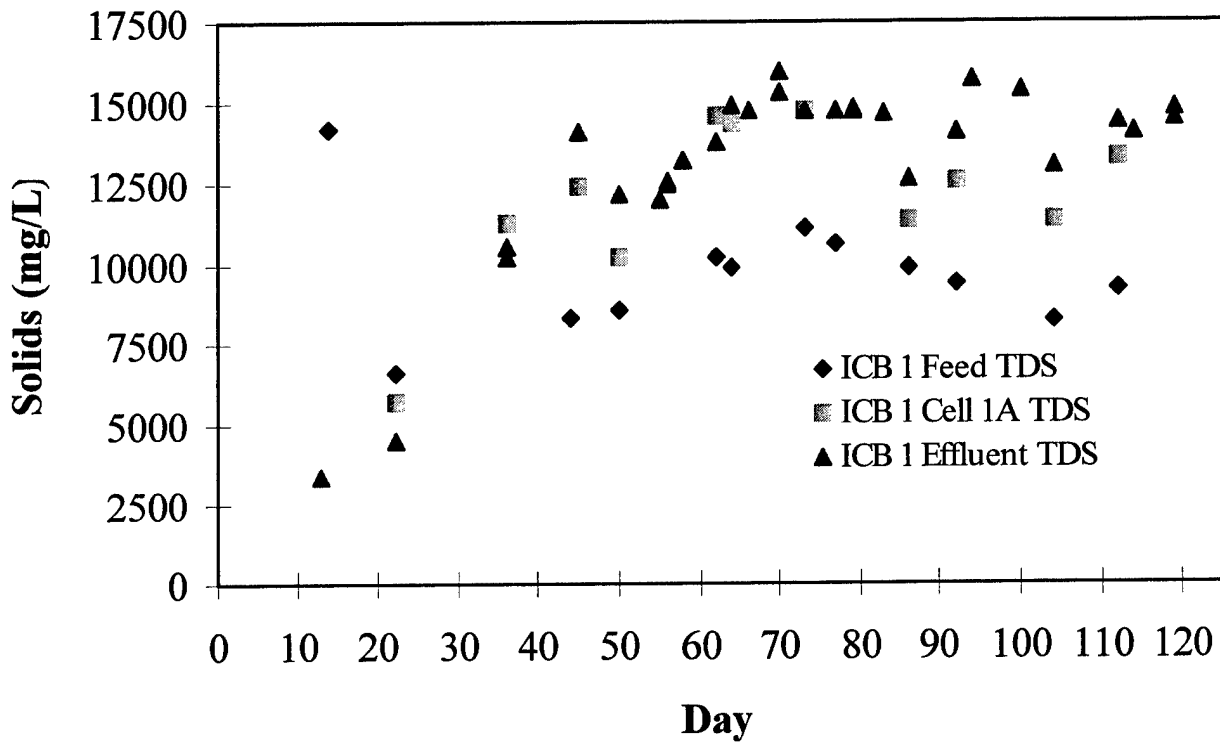

Figure 12. TDS Results for ICB 1

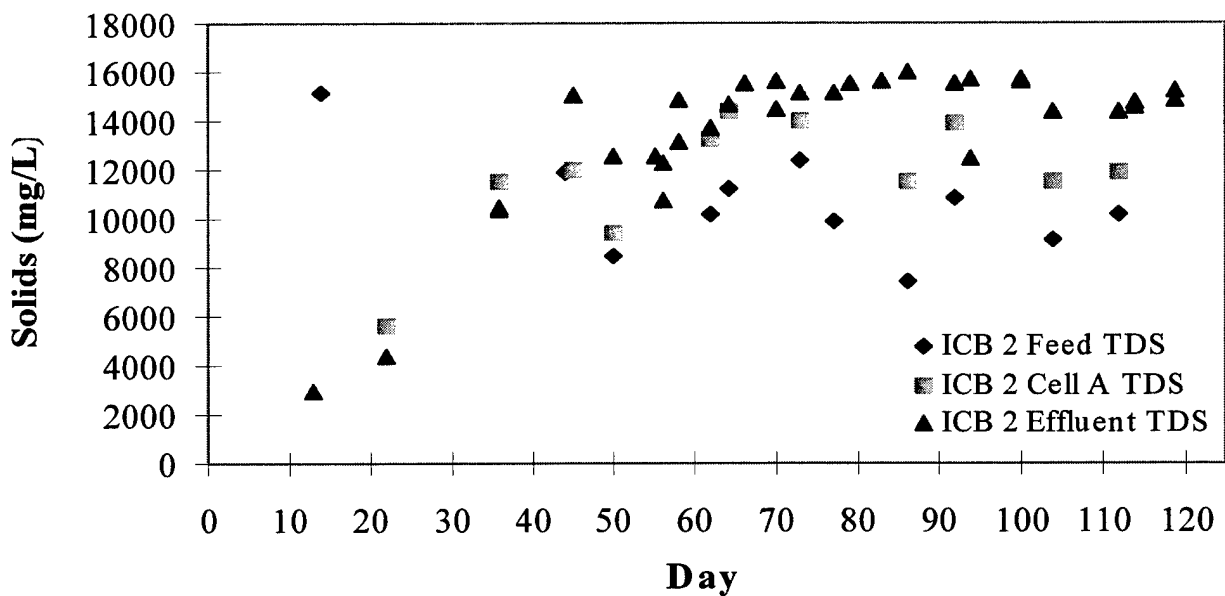

Figure 13. TDS Results for ICB 2

The total solids (TS) in the biofeed and effluents from both reactors were analyzed using the student t-test. Data points used were collected during sampling events in the 60-day steady-state period. Results of the TS are listed in Tables 10 and 11.

Table 10. Results of the Student t-test for TSs in ICB 1 and 2 Biofeeds

ICB 1 Biofeed TS (mg/L)	ICB 2 Biofeed TS (mg/L)	t-Test: Paired Two Sample for Means	Variable 1	Variable 2
10494.00	10279.10	Mean	10228.44	10424.35
10120.14	11408.40	STD Error	787.87	477.05
11554.27	12500.90	Observations	8.00	8.00
10347.60	7870.00	Hypothesized Mean Difference	0.00	
9917.50	11035.30	df	7.00	
8931.00	9812.00	t Stat	-0.43	
9635.30	10474.10	P stat (T<=t) one-tail	0.34	
		t Critical one-tail	1.89	
		P stat (T<=t) two-tail	0.68	
		t Critical two-tail	2.36	

A p-stat value >0.05 indicates no significant difference between variables at the 95% confidence level. Results of the student t-test indicate no significant statistical difference in the biofeed TSs between ICBs 1 and 2 at the 95% confidence level.

Table 11. Results of the Student t-test for TSs in ICB 1 and 2 Effluents

ICB 1 Effluent TS (mg/L)	ICB 2 Effluent TS (mg/L)	t-Test: Paired Two Sample for Means	Variable 1	Variable 2
13930.57	14233.83	Mean	15714.98	15669.36
15025.51	15022.97	Std Error	283.91	165.29
15012.00	15826.35	Observations	24.00	24.00
16330.71	14683.86	Hypothesized Mean Difference	0.00	
15851.47	15846.62	df	23.00	
15461.38	15421.51	t Stat	0.13	
15193.31	15418.70	P stat (T<=t) one-tail	0.45	
15404.00	15882.97	t Critical one-tail	1.71	
15446.40	15685.20	P stat (T<=t) two-tail	0.90	
15725.47	16306.33	t Critical two-tail	2.07	
15641.29	16286.40			
13484.70	16647.30			
15290.20	16087.00			
19471.30	13395.00			
18974.00	16623.00			
16939.50	16303.00			
17796.20	16554.00			
16216.00	15271.00			
15235.53	15134.13			
14759.67	15254.00			
14616.23	15430.40			
15293.40	16767.70			
15033.00	16250.00			

A p-stat value >0.05 indicates no significant statistical difference between the variables at the 95% confidence level. Results of the student t-test indicate no significant statistical difference in the TSs between ICBs 1 and 2 at the 95% confidence level.

3.8 Temperature.

Temperature is an important parameter to track since the metabolic rate of a biomass may be affected by temperature changes. However, in Demo and EDS testing, which had seasonal variations in temperature, the metabolic rate of the biomass did not appear to be affected. Temperature measurements of the ICB feeds and effluents throughout the PWS testing were very stable since the ICBs were in a controlled environment for the duration of the testing. The temperature of the ICB 1 feed was consistently higher than the ICB 2 feed (27°C versus 23°C) since the feed required constant stirring and was placed on a stir plate that generated some heat, even though it was not a hotplate. The temperatures within the ICBs were consistently about 23°C.

3.9

Thiodiglycol.

Thiodiglycol is the principle organic compound in the HD hydrolysate. During ramp-up, TDG analysis was conducted by the ECBC Biotechnology Team. The results of the TDG analysis during ramp-up are listed in Appendix C. Once the ICB biomasses reached steady state, the ICB biofeeds were sampled twice per 4-L feed batch. Field duplicates and effluent composite samples were also taken during the steady-state period. The effluent from each ICB was sampled for TDG four times per feed batch. A summary of all TDG results is presented in Table 12. These data include results from field duplicates and effluent composite samples.

Table 12. Summary of TDG Results from Steady-State Operation

Sample Location	Mean (mg/L)	Min (mg/L)	Max. (mg/L)	Std-D (mg/L)	No. of Observations	No. BDL*
ICB 1 unfiltered (HD hydrolysate)						
Feed	5592	4205	7614	659	12	---
Effluent	56.8	BDL	193	61.0	22	9
ICB 2 filtered (HD hydrolysate)						
Feed	5416	4108	6373	585	12	---
Effluent	37.5	BDL	202	54.7	24	11

*BDL = below detection limit (1.0 mg/L).

NOTE: BDL results were treated as zero in the statistical summary.

The calculated average TDG consumption rates in the PWS ICBs during the 60-day steady-state period are shown in Table 13 in comparison to the EDS ICB results. Despite the occurrence of detectable TDG levels in the PWS ICB effluents, the consumption rates compare favorably to Demo I ICB and EDS ICB results. The TDG consumption for ICB Demo 1 is based on the validation period samples. The calculated TDG consumption for the EDS ICB is based on the final 60-days of the EDS study.

Table 13. TDG Results in PWS ICBs Versus Demo I and EDS ICB

	Average TDG consumption rate (Mg/Day/L)
PWS ICB 1 (unfiltered HD hydrolysate)	1083
PWS ICB 2 (filtered HD hydrolysate)	1076
Demo I ICB	612
EDS ICB	1069

3.10 Operational Issues.

Operation of the ICBs started on 23 January with the inoculation of the reactors with 32.5 mL of activated sludge from Back River Publicly-owned treatment works. The reactors were filled to one-half capacity until the culture was acclimated with the feedstock. Each cell of the reactor was fed 32 mL of their respective biofeeds on Day 1 (23 Jan). The reactors were put in continuous feed mode on Day 10, the last day of acclimation and the first day of ramp-up. Operation of the reactors is straightforward with the Applikon biocontrollers caring for automated moving of feeds and effluents and for pH control. These control systems functioned without incident for the entire test.

The ramp-up period was 20 days longer than the planned 30 days. The ICB inoculation volume was kept at 5% of the ICB working volume. This low start-up volume was used to closely resemble the start-up of the pilot-scale reactor. Secondly, we have found from past experience that starting with a large volume of concentrated sludge has led to foaming problems from the die-off of larger quantities of culture and release of excess ammonia into the reactor. A larger inoculum volume should be tried in the future with the hopes of shortening the ramp-up period. However, some attention should be given to expected reactor volumes and available start-up inoculum at the full-scale facility, as well as the cost of transporting a large quantity of culture to the facility.

The ramp-up feed schedule may have been more conservative than necessary. The effluent and Cell 1 COD were used as an indicator of the ICB biomass health and performance. Due to limited experiences with HD bioreactors, no strict guidelines have been established for monitoring culture COD levels. As a practice, we have relied on the experiences of past studies. In the Demo and EDS pilot studies, the COD in the first chamber of the ICB rarely got above 3500 mg/L. On the two occasions when it did in this study, the reactor eventually went into an over-feed situation and feed had to be stopped. On Days 38 and 42 (1 and 5 March), elevated COD levels in Cell 1 of Reactor 1 prompted the decision to temporarily stop feed to the ICBs so the biomasses could catch up with the increased feed strength. On restart, the feed was reduced to three-fourths design strength and once again ramped-up to full strength. Prior to steady-state operation, the COD was allowed to rise above 3500 mg/L without halting the feed. The reactor seemed to be able to continue operation at the elevated COD levels.

Another event that caused a short stoppage in the feed schedule and has been a topic of interest with ICBs is the build-up and sloughing of biomaterial from the immobilized substrate. One argument against the use of ICBs is the limited ability to control biomass accumulation. In sequencing batch systems, the culture is free floating and thus can be removed by a process called wasting. In the ICB system, the culture is attached to a growth substrate. Wider fluctuations in the effluent TSS can be observed, especially if the system is either upset or overfed. Generally, the ICB is thought to produce lower TSS in the effluent, lending the effluent to easier downstream processing (recycling). In a glass laboratory ICB, the biomass accumulation can be observed. Once channeling of air through the culture is observed, a practice of stirring the reactor to break up the channeling may be employed. Stirring of the reactor normally causes a short increase in the effluent TSS. This stirring procedure was performed on

the reactors, and the increase in TSS was noted. An unexpected upset occurred in ICB 1 when the transfer line from Cell A to Cell B became clogged overnight. This caused head pressure in the ICB to exceed the air input pressure, resulting in air shutoff while still feeding the reactor. Feed was stopped for 1 day to allow the reactor to recover. No upset of this type was observed in ICB 2 where the glass transfer port is twice as large in diameter as the transfer line in ICB 1. Since design of a full-scale ICB would be considerably different, this type of upset would not be expected.

This type of upset did not occur in pilot testing. The pilot was not stirred during the 5-month operation period. Statistical analysis of the ICB effluent TSS indicate there is no significant difference between the amount of TSS generated during the 60-day steady-state period between Reactors 1 and 2.

Solid buildup in the reactors displaced a significant portion of the reactor operating volume. On start-up, each cell of the reactor had a liquid operating volume of 630 mL. On shutdown of the ICBs at the end of the test, only 350 mL of effluent could be drained from ICB 1 and 375 mL from ICB 2. Additional biomass still present in the reactor would account for additional unrecovered effluent volume. On shutdown, the ICB culture remaining after effluent drainage was collected and shipped for additional analysis of solids.

Since TDG breakthrough levels averaged 1% or less over the study period, small differences between design and operation could make the difference in complete degradation of TDG in the effluent. A decrease in feed loading or an increase in the HRT should allow a sustainable none detect level for TDG in the effluent. Decreasing the feed loading may also decrease the biomass accumulation within the reactor and decrease the likelihood of biomass sloughing.

Design differences of note are the three-chambered design of the pilot versus two chambers in laboratory-scale reactors. In addition, while the operational temperature of the ICB culture was consistent throughout the study, it was lower than the temperature of the EDS and higher than that of the demo study. Since temperature affects the cultures metabolic rate, it would stand to reason that a higher culture temperature could improve TDG degradation. During the demo study, only 67% of the design rate of TDG removal was obtained. During the EDS, the TDG removal was greater than the design rate. The demo culture temperature was lower than the EDS and the PWS laboratory study.

4. CONCLUSIONS

4.1 Feed and Effluent Characterization.

The Immobilized Cell Bioreactor (ICB) feeds and effluents were characterized as planned. Characterization data are available in appendixes in this report.

4.2 Impact of HD Hydrolysate Solids.

The biofeeds of the two ICBs differed in the amount of solids that were in the HD hydrolysate from hydrolysis of the HD heel material. The feed in ICB 1 contained a representative quantity of heel from the actual HD hydrolysate. The hydrolysate used to make ICB 2 biofeed was settled prior to mixing. The total suspended solid (TSS) values measured in the biofeed for the two ICBs were presented in Section 3. Statistical analysis showed a significant difference in the amount of TSS in the two ICB biofeeds. The TSS of the effluents was also analyzed, and the results are also presented in Section 3. Statistical analysis indicated there was no significant difference in the TSS of the two reactor effluents at the 95% confidence level. Any difference in the biofeed TSS attributable to the hydrolyzed heel material was not apparent in the TSS of the reactor effluents. Perhaps this difference is masked by the increase in biomaterial in the effluent. If this is the case, we cannot prove it from this test. There is no net effect observed by the addition of hydrolyzed heel material on the ICB effluent TSS. There is no significant statistical difference in effluent TSS between ICBs 1 and 2.

In each of the ICBs, the microbial culture adapted and increased at similar rates. There was no apparent effect on the ramp-up of ICB 1 from adding hydrolyzed heel material into the biofeed.

In each of the reactors, biomass accumulated to levels where air channeling could be observed. Both reactors were stirred on Day 93 to break-up air channeling. Higher TSS was observed in both ICB effluents after stirring. The ICB 1 became upset after the transfer line from Cell 1 to Cell 2 became clogged overnight. The transfer line between cells in ICB 1 is approximately ¼ in. inside diameter (i.d.). Neither plugging nor upset was observed in ICB 2 as a result of the stirring. The transfer line between Cells 1 and 2 in ICB 2 is larger at ½ in. i.d. The feed to ICB 1 was turned off for 1 day to allow the culture to recover. No sampling events were missed or postponed as a result of the upset.

Other than the clogging of the transfer line and settling of the HD hydrolysate for feed, there were no other operational problems associated with solids in the reactors.

4.3 Thiodiglycol (TDG) Destruction.

The U.S. Army Chemical Biological Center (ECBC) Analytical Chemistry Team (ACT) measured TDG in reactors' biofeeds and effluents during the 60-day steady-state period. Complete results are available in appendixes in this report. The TDG concentrations reported during steady-state operations were compared using the student t-test. Data used included only data points from the scheduled sampling events. Field duplicated and composite samples are not included in this analysis. The statistical results are reported in Table 14.

Table 14. Results of Statistical Analysis of TDG Concentrations in the ICB Biofeeds

ICB 1 Biofeed TDG (mg/L)	ICB 2 Biofeed TDG (mg/L)	t-Test: Paired Two Sample for Means	Variable 1	Variable 2
6000.00	6024.00	Mean	5750.28	5505.71
7614.00	5759.00	STD Error	361.24	207.27
6120.00	6373.00	Observations	7.00	7.00
4916.00	5024.00	Hypothesized Mean Difference		
5361.00	4976.00	df	0.00	
5410.00	5120.00	t Stat	6.00	
4831.00	5264.00	P Stat(T<=t) one-tail	0.84	
		t Critical one-tail	0.21	
		P Stat(T<=t) two-tail	1.94	
		t Critical two-tail	0.43	
			2.44	

A p-stat value >0.05 indicates no significant statistical difference. Results of the student t-test of the biofeeds from the 60-day steady-state period using ACT-reported TDG concentrations indicate no significant statistical difference between TDG in the two ICB biofeeds at the 95% confidence level.

Results of statistical analysis comparing TDG concentrations in the ICB effluents are presented in Table 15. Concentrations below detection limits (BDL) were treated as zero.

Table 15. Results of Statistical Analysis of TDG Concentrations in the ICB Effluents

ICB 1 Effluent TDG (mg/L)	ICB 2 Effluent TDG (mg/L)	t-Test: Paired Two Sample for Means	Variable 1	Variable 2
37.11	59.64	Mean	64.99	40.55
80.72	13.25	STD Error	16.00	13.94
0.00	0.00	Observations	16.00	16.00
0.00	0.00	Hypothesized Mean Difference	0.00	
192.80	0.00	df	15.00	
114.60	20.48	t Stat	0.95	
121.70	31.33	P Stat(T<=t) one-tail	0.18	
115.50	14.70	t Critical one-tail	1.75	
162.70	0.00	P Stat (T<=t) two-tail	0.36	
82.53	0.00	t Critical two-tail	2.13	
47.35	0.00	t Critical two-tail	2.13	
0.00	88.67			
84.82	67.71			
0.00	202.10			
0.00	113.80			
0.00	37.11			

A p-stat value >0.05 indicates no significant statistical difference. Results of the student t-test comparing ICBs 1 and 2 effluent TDG concentrations indicate no significant statistical difference between the two effluent streams. There is no difference observed in the ICBs' abilities to remove TDG whether heel material is added to the biofeed or not.

Even though there was TDG detection in the ICB effluents, the ICB performed quite well when fed hydrolyzed mustard from actual chemical rounds. When compared to previous studies using the pilot-scale 1000-gal ICB, the laboratory-scale systems' consumption was higher on a working per liter working volume basis. A brief comparison of the chemical oxygen demand (COD) and TDG consumption between pilot and laboratory-scale ICBs is presented in Table 16. COD and TDG values are normalized to reflect TDG input/output per liter of reactor volume. Units are milligrams per day input per liter of reactor volume. Even though there is some TDG breakthrough in the ICB-projectile washout system (PWS), the median detected TDG level is low over the duration of the study. The calculated TDG consumption rate for the ICB-PWS compared favorably to Demonstration (Demo) I and Engineering Design Study (EDS) testing. Operational optimization and reactor configuration may be able to eliminate effluent TDG in a scaled-up ICB. The TDG breakthrough may also be eliminated by either decreasing loading in the biofeed or increasing the hydraulic residence time (HRT).

Table 16. Comparison of COD and TDG Consumption Between the Laboratory and Pilot Scale ICBs

Test ICB	COD Input (mg/Day/L)	COD Output (mg/Day/L)	COD Removal efficiency	TDG Input (mg/Day/L)	TDG Consumption (mg/Day/L)
PWS ICB 1 (Unfiltered HD hydrolysate)	2374.8	348.9	85.5	1141	1128
PWS ICB 2 (Filtered HD hydrolysate)	2411.0	349.8	85.6	1092	1084
Demo I ICB	1297.6	115.5	91.1	612	612
EDS ICB	2266.0	216.6	90.4	1069	1069

The specific objectives of this test from Section 1 of this report follow:

- Confirm the ability of the laboratory-scale ICBs to effectively treat the PWS-generated HD hydrolysate at the hydraulic residence time (HRT) that represents full-scale design.
- Assess the impact of suspended solids in HD hydrolysate on ICB performance.

- Confirm the ability of the laboratory-scale ICBs to eliminate thiodiglycol (TDG) in the HD hydrolysate.
- Characterize ICB effluents.

The ICBs were able to treat the HD hydrolysate generated from the PWS. Even though some TDG was detected in the reactor effluents, the reactors were able to treat the HD hydrolysate at unit loadings higher than those in Demo 1 and EDS pilot-scale testing.

The hydrolyzed heel material present in the HD hydrolysate was removed from the biofeed from ICB 2. Heel material was left in the biofeed to Reactor 1 at the same concentration as that used in the HD hydrolysate. Statistical analysis of the TDG detected in the effluent streams indicates no significant difference in performance from the addition of the hydrolyzed heel material.

While TDG was detected in the effluents from both reactors at various times, the overall average TDG removal efficiencies were still >89%. However, consumption rates were comparable to EDS testing using HD hydrolysate from ton containers that is a cleaner and more easily degradable food source for the ICB culture. Regular elimination of TDG to non-detection levels should be attainable through adjustment of feed loading, reactor design, and operational optimization in a larger bioreactor system.

The ICB biofeed and effluents underwent extensive testing for chemicals of concern. Many of the chemical compounds of interest were below detectable limits. These data from effluent characterization and analysis for chemicals of interest are available in Section 3 and the appendixes to this report.

Blank

APPENDIX A

SUMMARY OF PROCESS MONITORING ANALYSIS
DURING 60-DAY STEADY-STATE PERIOD

ICB 1 Unfiltered Feed

	vol	loading	COD	input	PO4	NH3-N	TSS	VSS	TDS	Temp	pH
	(mL)	cod	(mg/L)	(mg/day)	(mg/L)	(mg/L)	(mg/L)	(mg/L)	(mg/L)	°C	
Mean	252	11969	12027	3016	71.4	182.2	405.9	207.6	9822.5	26.6	11.2
Min	252	10000	10000	2520	16.0	142.0	207.7	41.2	8231.0	23.8	10.2
Max	252	12600	12600	3175	98.5	220.0	700.0	444.0	11109.6	28.0	11.7
Std-D	0	759	883	191	28.2	28.2	166.0	152.9	887.3	1.3	0.5

ICB 1A

	COD	COD	PO4	NH3-N	TSS	VSS	TDS	Temp	pH	D.O.
	mg/L	(% rem.)	mg/L	mg/L	(mg/L)	(mg/L)	(mg/L)	°C		(%)
Mean	3845	66.7	51.5	78.8	588.6	212.9	13169.6	23.1	7.4	86.9
Min	2530	46.4	16.0	16.4	174.6	87.4	11341.0	22.9	7.1	60.2
Max	5480	79.4	75.0	124.0	1467.0	339.0	14740.0	23.5	7.8	97.3
Std-D	1194	11.4	20.8	37.0	434.4	97.4	1466.3	0.2	0.3	12.8

ICB 1B

	1B		COD		ICB 1 COD			
	COD	COD	Output	% COD Removal	Consumption	PO4	NH3-N	TSS
	(mg/L)	(% rem.)	(mg/day)	(output/input)	(mg/Day)	(mg/L)	(mg/L)	(mg/L)
Mean	1758	85.5	443.2	85.5	2617.4	56.2	77.5	1062.5
Min	1110	80.9	279.7	81.2	2121.8	29.8	14.0	134.3
Max	2310	90.8	582.1	91.0	2835.0	99.8	162.0	3734.3
Std-D	302	2.5	76.1	2.5	134.5	18.4	46.6	1045.7

ICB 1 Continued

	VSS	TDS	Temp	pH	D.O.
	(mg/L)	(mg/L)	°C		(%)
Mean	417.3	14652.5	23.2	6.98	96.9
Min	85.1	12677.5	22.8	6.49	85.5
Max	1803.0	15947.6	24.0	7.15	100.0
Std-D	409.3	764.8	0.4	0.14	3.2

ICB 2 Feed

	vol	COD	COD loading	COD Input	PO4	NH3-N	TSS	VSS	TDS	pH
	(mL)	(mg/L)	(mg/L)	(mg/Day)	(mg/L)	(mg/L)	(mg/L)	(mg/L)	(mg/L)	
Mean	252	12207	12149	3062	76.8	173.2	272.1	130.1	10152.3	11.0
min	252	10480	10480	2641	23.8	150.0	59.1	21.7	7403.6	10.0
max	252	12710	12710	3203	104.5	195.0	681.0	320.4	12350.0	11.6
std-d	0	608	636	160	26.9	11.7	205.4	102.7	1472.2	0.5

ICB 2A

	COD	COD	PO4	NH3-N	TSS	VSS	TDS	Temp	pH	D.O.
	(mg/L)	(% rem.)	(mg/L)	(mg/L)	(mg/L)	(mg/L)	(mg/L)	°C		(%)
Mean	4432	66	86.1	81.6	398.1	207.6	12898	23.2	7.5	86.2
min	3520	41	57.8	50.8	161.8	31.1	11480	22.8	7.2	65.2
max	7090	100	129.5	164.8	797.0	485.6	14367	23.5	7.8	100.0
std-d	1025	14	23.4	35.2	236.6	165.8	1246.2	0.3	0.2	13.6

ICB 2B

	COD	COD	COD Output	% COD Removal	COD Consumption	PO4	NH3-N
	(mg/L)	(% rem.)	(mg/Day)	input/output	(mg/Day)	(mg/L)	(mg/L)
Mean	1762.8	85.8	444.2	85.6	2646.6	81.9	29.5
min	1520.0	83.4	383.0	82.9	2250.4	57.5	8.0
max	2080.0	87.9	524.2	87.5	2744.3	105.3	43.6
std-d	144.1	1.3	36.3	1.1	95.3	15.3	12.2

ICB 2B Continued

	TSS	VSS	TDS	Temp	pH	D.O.
	(mg/L)	(mg/L)	(mg/L)	°C		(%)
Mean	620.0	247.4	15049.3	23.1	7.0	95.5
min	158.4	58.9	12512.0	23.0	6.5	82.6
max	1563.2	541.0	16003.3	24.0	7.8	100.0
std-d	365.9	149.2	781.3	0.3	0.3	3.7

APPENDIX B

RESULTS FROM CHARACTERIZATION OF TETRYTOL HYDROLYSATE

The Tetrytol hydrolysate was analyzed for the following compounds of concern.

Chloride	Selenium	Acenaphthene	Total Dissolved Solids
Fluoride	Silver	Acenaphthylene	TOC(1)
Nitrate-N	Sodium	Anthracene	TOC(2)
Nitrite-N	Thallium	Benzo(a)anthracene	TOC(3)
o-Phosphate-P	Tin	Benzo(a)pyrene	TOC(4)
Sulfate	Vanadium	Benzo(b)fluoranthene	Total Suspended Solids
1,3,5-Trinitrobenzene	Zinc	Benzo(g,h,i)perylene	1,1,1-Trichloroethane
1,3-Dinitrobenzene	1,2,4-Trichlorobenzene	Benzo(k)fluoranthene	1,1,2,2-Tetrachloroethane
2,4,6-Trinitrotoluene	1,2-Dichlorobenzene	bis(2-Chloroethoxy)methane	1,1,2-Trichloroethane
2,4-Dinitrotoluene	1,3-Dichlorobenzene	bis(2-Chloroethyl)ether	1,1-Dichloroethane
2,6-Dinitrotoluene	1,4-Dichlorobenzene	bis(2-Ethylhexyl)phthalate	1,1-Dichloroethene
2-Amino-4,6-dinitrotoluene	2,2'-Oxybis(1-chloropropane)	Butyl benzyl phthalate	1,2-Dichloroethane
2-NT	2,4,5-Trichlorophenol	Carbazole	1,2-Dichloroethane-d4 (surr)
3,4-Dinitrotoluene	2,4,6-Tribromophenol (surr)	Chrysene	1,2-Dichloropropane
3-NT	2,4,6-Trichlorophenol	Dibenz(a,h)anthracene	2-Butanone
4-Amino-2,6-dinitrotoluene	2,4-Dichlorophenol	Dibenzofuran	2-Hexanone
4-NT	2,4-Dimethylphenol	Diethylphthalate	4-Methyl-2-pentanone
HMX	2,4-Dinitrophenol	Dimethylphthalate	Acetone
Nitrobenzene	2,4-Dinitrotoluene	Di-n-butylphthalate	Benzene
RDX	2,6-Dinitrotoluene	Di-n-octylphthalate	Bromodichloromethane
Tetryl	2-Chloronaphthalene	Fluoranthene	Bromofluorobenzene (surr)
Mercury	2-Chlorophenol	Fluorene	Bromoform
Aluminum	2-Fluoro-4-nitrophenol	Hexachlorobenzene	Bromomethane
Antimony	2-Fluorobiphenyl (surr)	Hexachlorobutadiene	Carbon Disulfide
Arsenic	2-Fluorophenol (surr)	Hexachlorocyclopentadiene	Carbon Tetrachloride
Barium	2-Methylnaphthalene	Hexachloroethane	Chlorobenzene
Beryllium	2-Methylphenol	Indeno(1,2,3-cd)pyrene	Chloroethane
Cadmium	2-Nitroaniline	Isophorone	Chloroform
Calcium	2-Nitrophenol	Naphthalene	Chloromethane
Chromium	3,3'-Dichlorobenzidine	Nitrobenzene	cis-1,3-Dichloropropene
Cobalt	3-Nitroaniline	Nitrobenzene-d5 (surr)	Dibromochloromethane
Copper	3-Pentanol, 2,2-dimethyl-	N-Nitroso-di-n-propylamine	Ethylbenzene
Iron	4,6-Dinitro-2-methylphenol	N-Nitrosodiphenylamine	Methylene chloride
Lead	4-Bromophenyl-phenylether	Pentachlorophenol	Styrene

Magnesium	4-Chloro-3-methylphenol	Phenanthrene	Tetrachloroethene
Manganese	4-Chloroaniline	Phenol	Toluene
Molybdenum	4-Chlorophenyl-phenylether	Pyrene	Toluene-d8 (surr)
Nickel	4-Methylphenol	Terphenyl-d14 (surr)	trans-1,3-Dichloropropene
Potassium	4-Nitroaniline		Trichloroethene

Of the compounds listed above, the following were detected.

Compound	Result	Units	Sample Date
Nitrite-N	5380	MG/L	3/21/2002
Sulfate	122	MG/L	3/21/2002
Nitrate-N	99.1	MG/L	3/21/2002
Potassium	18300	µG/L	3/21/2002
Aluminum	4190	µG/L	3/21/2002
Arsenic	32.5	µG/L	3/21/2002
Barium	25.1	µG/L	3/21/2002
Beryllium	12.4	µG/L	3/21/2002
Iron	274	µG/L	3/21/2002
Nickel	37.8	µG/L	3/21/2002
Selenium	88	µG/L	3/21/2002
Sodium	34500000	µG/L	3/21/2002
Tin	173	µG/L	3/21/2002
Zinc	172	µG/L	3/21/2002
Magnesium	1450	µG/L	3/21/2002
2,4-Dinitrophenol	46000	µG/L	3/21/2002
TOC (4)	16000	MG/L	3/21/2002
TOC (1)	16000	MG/L	3/21/2002
TOC (2)	15800	MG/L	3/21/2002
TOC (3)	16100	MG/L	3/21/2002

APPENDIX C

RESULTS OF TDG ANALYSIS DURING RAMP-UP PERIOD

Sample Date	Feed Load (% design)	ICB 1			ICB 2		
		Feed	Cell 1A	Effluent	Feed	Cell 2A	Effluent
13-Feb	50		24.95	BDL		39.3	BDL
13-Feb	50		24.46	BDL		39.7	BDL
13-Feb	50		23.98	BDL		40.2	BDL
18-Feb	50	1989	15.65	BDL		36.4	BDL
18-Feb	50	1996	16.29	BDL		36.6	BDL
18-Feb	50	2011	17.16	BDL		37.7	BDL
25-Feb	75		135.14	BDL		90.5	BDL
25-Feb	75		135.65	BDL		90.4	BDL
25-Feb	75		137.93	BDL		89.9	BDL
27-Feb	100	5349	472.86	BDL	5306	275.7	BDL
27-Feb	100	5336	471.43	BDL	5289	279.5	BDL
27-Feb	100	5364	471.79	BDL	5303	277.5	BDL
11-Mar	75	4588	1006.04	BDL	4500		BDL
11-Mar	75	4644	987.61	BDL	4578		BDL
11-Mar	75	4599	977.46	BDL	4543		BDL
14-Mar	87.5	2763.98	BDL	BDL	4009.14	542.78	BDL
3/14	87.5	2782.69	BDL	BDL	4075.82	538.28	BDL
3/14	87.5	2783.14	BDL	BDL	4113.99	527.32	BDL
3/18	87.5	4146.98	BDL	BDL	3893.17	207.14	5.26
3/18	87.5	4156.64	BDL	BDL	3909.39	204.62	5.69
3/18	87.5	4131.46	BDL	BDL	3892.31	206.77	5.60
3/20	87.5	3249.1	947.13	BDL	3782.92	899.22	1.74
3/20	87.5	3199.66	940.74	BDL	3707.2	872.74	1.87
3/20	87.5	3252.1	930.73	BDL	3745.73	873.1	1.80
3/25	100	5908.56	20.45	37.85	6440.27	376.52	BDL
3/25	100	5904.32	19.09	72.95	6464.56	386.39	BDL
3/25	100	5787.39	19.07	72.61	6471.45	390.49	BDL
3/27	100	5016.46	46.39	99.92	4851.72	288.37	89.16
3/27	100	4962.36	47.18	107.25	4787.29	274.25	92.67
3/27	100	4966.69	46.39	107.70	4637.84	279.13	92.38

BDL = below detection limit (1.0 mg/L). Instrument detection limit = 0.001713 µg

Thiodiglycol Concentration in Unfiltered Feed ICB*
During 60-Day Steady-State Operation Period

Sample Location	Sample ID	Sample Date	Result (mg/L)
Biofeed	PDIU01TU02AX	3/13/2002	4205
Biofeed	PDIU01TU02AX	3/13/2002	6108
Biofeed	PDIU01TU03AX	3/27/2002	6000
Biofeed	PDIU01TU03DX	4/5/2002	7614
Biofeed	PDIU01TU04AX	4/9/2002	6000
Biofeed	PDIU01TU04DX	4/18/2002	7614
Biofeed	PDIU01TU05AX	4/24/2002	5361
Biofeed	PDIU01TU05DX	5/6/2002	5410
Biofeed	PDIU01TU06AX	5/14/2002	4831

TDG Effluent Concentration in Unfiltered Feed ICB

Sample ID	Date	TDG (µg/mL)	Sample ID	Date	TDG (µg/mL)
PDIU03TU02AX	3/13/2002	19.51	PDIU03TU04CX	4/15/2002	115.5
PDIU03TU02BX	3/19/2002	<1	PDIU03TU04DX	4/18/2002	162.7
PDIU03TU02CX	3/21/2002	<1	PDIU03TU05AX	4/24/2002	82.53
PDIU03TU02DX	3/25/2002	37.11	PDIU03TU05BX	4/26/2002	47.35
PDIU03TU03AX	3/27/2002	80.72	PDIU03TU05CX	5/2/2002	<1
PDIU03TU03BX	3/29/2002	<1	PDIU03TU05DX	5/6/2002	84.82
PDIU03TU03CX	4/2/2002	<1	PDIU03TU06AX	5/14/2002	<1
PDIU03TU03DX	4/5/2002	192.8	PDIU03TU06BX	5/16/2002	<1
PDIU03TU04AX	4/9/2002	114.6	PDIU03TU06CX	5/21/2002	<1
PDIU03TU04BX	4/11/2002	121.7			

Statistical Summary of TDG Values from the Unfiltered Feed ICB

Unfiltered Feed		Unfiltered Effluent	
Measurement	Value (mg/L TDG)	Measurement	Value (mg/L TDG)
Mean	5841	Mean	56
		Min	0
		Max	192
		STD-D	61
		Number	22
		Number BDL	9

NOTES:

Data include field duplicates and composite samples, which make values different from those used in the statistical in the report body.

TDG Values if <1 were treated as zero in statistical summary. Sample detection limit = 1.0 mg/L.

* Reported by the Analytical Chemistry Team

APPENDIX D

THIODIGLYCOL CONCENTRATION IN FILTERED FEED ICB*
DURING 60-DAY STEADY-STATE OPERATION PERIOD

Sample Location	Event	Sample ID	Date	TDG (mg/L)
Biofeed	Event A	PDIF01TF02AX	3/13/2002	4108
Biofeed	Event D	PDIF01TF02DX	3/25/2002	5819
Biofeed	Event A	PDIF01TF03AX	3/27/2002	6024
Biofeed	Event D	PDIF01TF03DX	4/5/2002	5759
Biofeed	Event A	PDIF01TF04AX	4/9/2002	6373
Biofeed	Event D	PDIF01TF04DX	4/18/2002	5024
Biofeed	Event A	PDIF01TF05AX	4/24/2002	4976
Biofeed	Event D	PDIF01TF05DX	5/6/2002	5120
Biofeed	Event A	PDIF01TF06AX	5/14/2002	5265
Biofeed	Event 1	PDIF01TFXX0X	3/21/2002	5566
Biofeed	Event 2	PDIF01TFXX2X	4/23/2002	5530
Biofeed	Event 3	PDIF01TFXX3X	5/21/2002	5422

TDG Concentration in Effluent from the Filtered Feed (2) ICB.

Sample ID	Date	Result	Sample ID	Date	Result
PDIF03TF02AX	3/13	96.4	PDIF03TF04DX	4/18	14.7
PDIF03TF02BX	3/19	<1	PDIF03TF05AX	4/24	<1
PDIF03TF02CX	3/21	<1	PDIF03TF05BD	4/26	<1
PDIF03TF02DX	3/25	59.64	PDIF03TF05BX	4/26	<1
PDIF03TF03AX	3/27	13.25	PDIF03TF05CX	5/2	88.67
PDIF03TF03BD	3/29	<1	PDIF03TF05DX	5/6	67.71
PDIF03TF03BX	3/29	<1	PDIF03TF06AX	5/14	202.1
PDIF03TF03CX	4/2	<1	PDIF03TF06BX	5/16	113.8
PDIF03TF03DX	4/5	<1	PDIF03TF06CX	5/21	37.11
PDIF03TF04AX	4/9	<1	PDIF03TFXX0X	4/11	13.61
PDIF03TF04BX	4/11	20.48	PDIF03TFXX2X	4/24	<1
PDIF03TF04CX	4/15	31.33	PDIF03TFXX3X	5/21	142.2

* Reported by the Analytical Chemistry Team

Statistical Summary of TDG Values from Filtered Feed ICB Feed and Effluent

Filtered Feed		Effluent	
Measurement	Value	Measurement	Value
average	5415.5	average	37.54167
min	4108	min	0
max	6373	max	202.1
std-d	585.4016	std-d	54.70974
number	12	number	24
		number BDL	11

NOTES:

Results of <1 were treated as zero in statistical summary. Sample detection limit = 1.0 mg/L.

Data include field duplicates and composite samples, which make values different from those used in the statistical in the report body.

APPENDIX E

RESULTS OF TCLP ANALYSIS OF ICB SOLIDS

The solids removed from ICB Cell 1A at the end of the study were analyzed off-site for the compounds listed below.

Arsenic	1,2-Dichloroethane	2,4-Dinitrotoluene
Barium	1,4-Dichlorobenzene	2-Methylphenol
Cadmium	2-Butanone	4-Methylphenol
Chromium	Benzene	Hexachlorobenzene
Lead	Carbon Tetrachloride	Hexachlorobutadiene
Mercury	Chlorobenzene	Hexachloroethane
Selenium	Chloroform	Nitrobenzene
Silver	Tetrachloroethene	Pentachlorophenol
2,4,5-Trichlorophenol	Trichloroethene	Pyridine
2,4,6-Trichlorophenol	Vinyl chloride	1,1-Dichloroethene
2,4-Dinitrotoluene	Arsenic	1,2-Dichloroethane
2-Methylphenol	Barium	1,4-Dichlorobenzene
4-Methylphenol	Cadmium	2-Butanone
Hexachlorobenzene	Chromium	Benzene
Hexachlorobutadiene	Lead	Selenium
Hexachloroethane	Mercury	Nitrobenzene

Of the compounds listed, the following compounds were detected in the sample from ICB Cell 1A.

SampLocName	SampleID	StartDate	Compound Name	Result
			Barium	
ICB Cell-1	PDIF14TFXXXX	5/21/2002		0.115

The solids isolated from the HD hydrolysate were analyzed for the following compounds using TCLP.

Arsenic	2,4,5-Trichlorophenol
Barium	2,4-Dinitrotoluene
Cadmium	2-Methylphenol
Chromium	4-Methylphenol
Lead	Hexachlorobenzene
Mercury	Hexachlorobutadiene
Selenium	Hexachloroethane
Silver	Nitrobenzene

In the solids samples analyzed, the following compounds were detected using
TCLP.

Sample Location	Sample ID	Date	Compound	Result (mg/L)
Feed Solids	PDIF21TFXX0X	5/21/2002	Arsenic	0.448
Feed Solids	PDIF21TFXX0X	5/21/2002	Barium	0.0526

APPENDIX F

RESULTS OF METALS ANALYSIS FROM BIOFEED SAMPLES

Analysis was performed on biofeed samples taken along with composite effluent samples. Three composite samples were taken during the study period. Biofeed samples taken in conjunction with composite samples zero and three were analyzed for metals content.

Compound	Unfiltered Biofeed	Qualifier	Unfiltered Biofeed	Qualifier	Filtered Biofeed	Qualifier	Filtered Biofeed	Qualifier
	XX0X		XX3X		XX0X		XX3X	
	(µg/L)		(µg/L)		(µg/L)		(µg/L)	
Aluminum	1090		1440		1510		1980	
Antimony	5.8	U	6.6	J	5.8	U	5.8	U
Arsenic	150		215		134		173	
Barium	54.2		143		242		165	
Beryllium	0.9	U	0.9	U	0.9	U	0.9	U
Cadmium	410		870		4.2	J	12.4	
Calcium	9220		14200		10000		9500	
Chromium	27.8		108		1.1	U	9.6	J
Cobalt	274		327		284		316	
Copper	1100		1510		127		388	
Iron	39300		133000		964		1600	
Lead	411		1200		25.4		13	J
Magnesium	8060		13100		8520		16500	
Manganese	1790		2840		1740		2780	
Molybdenum	89.8		78.8		97.3		74.2	
Nickel	41.8		121		11	J	26.8	
Potassium	57600		53500		57200		52500	
Selenium	34		30.1		33.2		24	J
Silver	736		2200		7.2	J	2.3	U
Sodium	3370000		3690000		3500000		3570000	
Thallium	14.6	U	14.6	U	14.6	U	21	J
Tin	102		110		104		87.2	
Vanadium	3.7	U	3.7	U	3.8	J	4	J
Zinc	727		1530		545		1060	

Blank

APPENDIX G

RESULTS OF ANALYSIS FOR METALS IN THE ICB EFFLUENT COMPOSITE SAMPLES

Sample ID	Date	Compound	Result (µg/L)	Sample ID	Date	Compound	Result (µg/L)
PDIF03TFXX0X	4/11	Aluminum	1010	PDIU03TUXX0X	4/11	Cadmium	85.8
PDIF03TFXX0X	4/11	Arsenic	98.1	PDIU03TUXX0X	4/11	Calcium	8470
PDIF03TFXX0X	4/11	Barium	161	PDIU03TUXX0X	4/11	Chromium	30.2
PDIF03TFXX0X	4/11	Calcium	8790	PDIU03TUXX0X	4/11	Cobalt	110
PDIF03TFXX0X	4/11	Chromium	45.3	PDIU03TUXX0X	4/11	Copper	215
PDIF03TFXX0X	4/11	Cobalt	173	PDIU03TUXX0X	4/11	Iron	9270
PDIF03TFXX0X	4/11	Copper	92.4	PDIU03TUXX0X	4/11	Lead	143
PDIF03TFXX0X	4/11	Iron	2130	PDIU03TUXX0X	4/11	Magnesium	7900
PDIF03TFXX0X	4/11	Lead	46	PDIU03TUXX0X	4/11	Manganese	950
PDIF03TFXX0X	4/11	Magnesium	7290	PDIU03TUXX0X	4/11	Molybdenum	90.6
PDIF03TFXX0X	4/11	Manganese	928	PDIU03TUXX0X	4/11	Potassium	61500
PDIF03TFXX0X	4/11	Molybdenum	91.6	PDIU03TUXX0X	4/11	Silver	142
PDIF03TFXX0X	4/11	Nickel	27.6	PDIU03TUXX0X	4/11	Sodium	870000
PDIF03TFXX0X	4/11	Potassium	63000	PDIU03TUXX0X	4/11	Tin	53.5
PDIF03TFXX0X	4/11	Sodium	994000	PDIU03TUXX3X	4/11	Zinc	305
PDIF03TFXX0X	4/11	Zinc	281	PDIU03TUXX3X	5/21	Aluminum	416
PDIF03TFXX3X	5/21	Aluminum	903	PDIU03TUXX3X	5/21	Arsenic	87
PDIF03TFXX3X	5/21	Arsenic	88.7	PDIU03TUXX3X	5/21	Barium	149
PDIF03TFXX3X	5/21	Barium	331	PDIU03TUXX3X	5/21	Cadmium	169
PDIF03TFXX3X	5/21	Calcium	10300	PDIU03TUXX3X	5/21	Calcium	13000
PDIF03TFXX3X	5/21	Chromium	54.6	PDIU03TUXX3X	5/21	Chromium	45.7
PDIF03TFXX3X	5/21	Cobalt	186	PDIU03TUXX3X	5/21	Cobalt	173
PDIF03TFXX3X	5/21	Copper	78.9	PDIU03TUXX3X	5/21	Copper	294
PDIF03TFXX3X	5/21	Iron	2210	PDIU03TUXX3X	5/21	Iron	28500
PDIF03TFXX3X	5/21	Magnesium	10700	PDIU03TUXX3X	5/21	Lead	257
PDIF03TFXX3X	5/21	Manganese	1240	PDIU03TUXX3X	5/21	Magnesium	11200
PDIF03TFXX3X	5/21	Molybdenum	76.6	PDIU03TUXX3X	5/21	Manganese	1460
PDIF03TFXX3X	5/21	Nickel	74	PDIU03TUXX3X	5/21	Molybdenum	76.4
PDIF03TFXX3X	5/21	Potassium	63500	PDIU03TUXX3X	5/21	Nickel	63.6
PDIF03TFXX3X	5/21	Sodium	5500000	PDIU03TUXX3X	5/21	Potassium	45500
PDIF03TFXX3X	5/21	Tin	36.4	PDIU03TUXX3X	5/21	Silver	473
PDIF03TFXX3X	5/21	Zinc	409	PDIU03TUXX3X	5/21	Sodium	5200000
PDIU03TUXX0X	4/11	Aluminum	883	PDIU03TUXX3X	5/21	Tin	41.6
PDIU03TUXX0X	4/11	Arsenic	58.4	PDIU03TUXX0X	5/21	Zinc	629
PDIU03TUXX0X	4/11	Barium	85.3				

Blank

APPENDIX H

EFFLUENT SAMPLES INCLUDING 3.8% HD
WITH SOLIDS PARTIALLY SETTLED

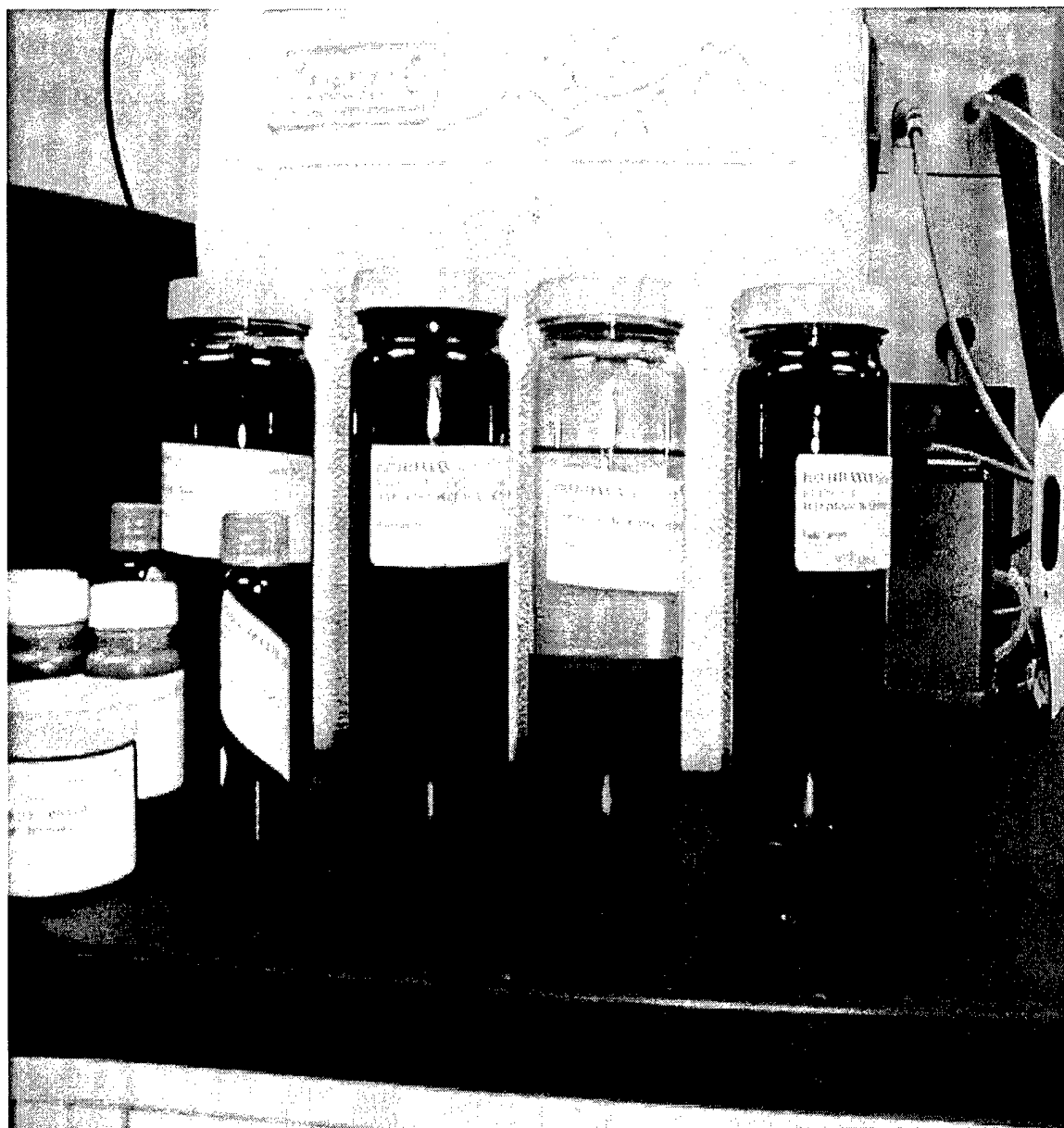

Blank

APPENDIX I

SOLIDS DATA FOR ICB 1

	ICB 1	ICB 1	ICB1	Icb 1	ICB 1	ICB 1	ICB 1	ICB 1	IBC 1
	Feed TSS	Feed VSS	feed TDS	Cell 1A TSS	Cell 1A VSS	Cell 1A TDS	Effluent TSS	Effluent VSS	Effluent TDS
Day	(mg/L)	(mg/L)	(mg/L)	(mg/L)	(mg/L)	(mg/L)	(mg/L)	(mg/L)	(mg/L)
13							83.00		3393.60
22	237.00	132.00	6682.2	264.00	153.20	5773.00	139.00	84.80	4510.80
36	1450.00	728.50		644.00	283.75	11247.00	572.00	239.75	10220.50
36							558.00	249.75	10562.25
45				303.00	233.25	12379.50	591.00	587.25	14121.50
50	187.50	46.00	8609.6	291.50	221.57	10216.50	291.50	221.57	12190.25
55									11962.00
56							237.60	123.60	12438.40
56							188.60	80.00	12579.60
58							240.20	164.60	13219.20
58							211.00	150.20	13206.40
62	262.00	41.20	10232.0	249.45	106.36	14547.60	174.17	114.17	13756.40
64	249.14	47.14	9871.0	174.60	87.40	14366.80	134.31	88.46	14891.20
66							252.00	116.22	14760.00
66							262.00	85.11	14765.60
70							383.11	237.33	15947.60
70							506.67	253.78	15344.80
73	444.67	69.78	11109.6	428.67	268.67	14740.00	675.78	337.78	14785.60
77	207.70	170.85	10620.0	356.86	201.71		479.71	183.14	14713.60
79							694.00	301.20	14710.00
79							598.00	250.00	14848.40
83							1046.67	445.33	14678.80
83							995.29	398.82	14646.00
86	472.00	380.50	9875.6	776.50	339.00	11344.67	807.20	293.20	12677.50
92	530.00	444.00	9387.5	897.20	334.40	12531.50	1177.20	480.40	14113.00
							3734.30	1112.80	15737.00
94							3270.00	1055.00	15704.00
							1983.00	547.00	14956.50
100							2367.00	795.00	15429.20
104	700.00	255.70	8231.0	1467.00	225.71	11341.00	3196.00	1803.00	13020.00
112	382.00	251.60	9253.3	358.33	140.33	13316.00	830.33	519.67	14405.20
							456.67	124.33	14303.00
114							501.23	135.00	14115.00
119							473.00	167.00	14820.40
119							503	171	14530.00

Parameter	Feed TSS	Feed VSS	Feed TDS	Cell 1a TSS	Cell 1a VSS	Cell 1a TDS	Effluent TSS	Effluent VSS	Effluent TDS
	(mg/L)	(mg/L)	(mg/L)	(mg/L)	(mg/L)	(mg/L)	(mg/L)	(mg/L)	(mg/L)
Mean	405.94	207.60	9822.50	588.58	212.95	13169.65	1062.53	417.28	14652.45
Min	207.70	41.20	8231.00	174.60	87.40	11341.00	134.31	85.11	12677.50
Max	700.00	444.00	11109.60	1467.00	339.00	14740.00	3734.30	1803.00	15947.60
Std-D	166.00	152.98	887.34	434.39	97.42	1466.35	1045.73	409.27	764.84
count	11.00	11.00	10.00	12.00	12.00	11.00	34.00	33.00	35.00

APPENDIX J

SOLIDS DATA FOR ICB 2

DAY	ICB 1 Feed TSS (mg/L)	ICB 1 Feed VSS (mg/L)	ICB1 feed TDS (mg/L)	Icb 1 Cell 1A TSS (mg/L)	ICB 1 Cell 1A VSS (mg/L)	ICB 1 Cell 1A TDS (mg/L)	ICB 1 Effluent TSS (mg/L)	ICB 1 Effluent VSS (mg/L)	IBC 1 Effluent TDS (mg/L)
36							996.00	324.8	10354.40
45				470	368.50	11993.50	385.00	366.5	15049.25
50	98.5	48.44	8440.6	456	416.25	9421.00	414.00	393.2	12555.75
55									12556.00
56							161.86	76.40	12306.40
56							169.73	74.93	10805.20
58							476.20	327.0	13148.00
58							641.71	435.7	14823.20
62	59.1	21.70	10220.0	161.83	39.83	13209.60	477.43	420.3	13756.40
64	177.6	26.80	11230.8	174.6	87.40	14366.80	310.57	144.3	14712.40
66							275.55	60.0	15550.80
66							232.89	68.2	15500.40
70							240.66	60.7	14443.20
70							228.22	58.9	15618.40
73	150.89	39.78	12350.0	231.78	31.11	13976.40	265.11	91.8	15156.40
77	157.43	113.14	9857.6	302.89			273.50	217.0	15145.20
79							404.57	328.3	15478.40
79							158.40	64.0	15526.80
83							688.33	260.7	15618.00
83							684.00	265.0	15602.40
86	466.4	320.40	7403.6	352	248.00	11500.67	644.00	227.0	16003.30
92	184.8	146.40	10850.5	482	308.80	13861.00	576.00		15511.00
94							883.00	280.5	12512.00
94							886.00	285.0	15737.00
100							718.00	232.4	15585.00
100							884.00	341.6	15670.00
104	681	194.00	9131.0	797	252.50	11480.00	916.00	541.0	14355.00
112	299.33	178.67	10174.8	682.67	485.60	11892.80	751.33	383.7	14382.80
114							688.00	180.8	14566.00
114							702.40	192.0	14728.00
119							1563.20	508.4	15204.50
119							1430.00	478.0	14820.00
Parameter	TSS	VSS	TDS	TSS	VSS	TDS	TSS	VSS	TDS
	(mg/L)	(mg/L)	(mg/L)	(mg/L)	(mg/L)	(mg/L)	(mg/L)	(mg/L)	(mg/L)
Mean	272.1	130.1	10152.3	398.1	207.6	12898	620.0	247.4	15049.3

Blank

APPENDIX K

HD HYDROLYSATE BREAKDOWN PRODUCTS

Sample ID	Sample Date	Compound Name	Result (mg/L)
PDIF24XXXXXX	1/23/2002	Dithiane	329
PDIF24XXXXXX	1/23/2002	Thiodiglycol	6145
PDIF24XXXXXX	1/23/2002	THIOX	10.4
PDIU24XXXXXX	1/23/2002	Dithiane	262.3
PDIU24XXXXXX	1/23/2002	Thiodiglycol	5699
PDIU24XXXXXX	1/23/2002	THIOX	11.53

Blank

APPENDIX L

ICB EFFLUENT CHARACTERIZATION

The ICB effluents were subject to extensive chemical characterization. Of the analyses performed, the following compounds were detected.

Compound	Method Name	Result	Units	Sample ID	Sample Date
Mercury	Mercury-liquid	0.212	µG/L	PDIU03TUXX0F	3/21/2002
Potassium	Metals	61500	µG/L	PDIU03TUXX0X	4/11/2002
Magnesium	Metals	10700	µG/L	PDIF03TFXX3X	5/21/2002
Manganese	Metals	1240	µG/L	PDIF03TFXX3X	5/21/2002
Molybdenum	Metals	76.6	µG/L	PDIF03TFXX3X	5/21/2002
Nickel	Metals	74	µG/L	PDIF03TFXX3X	5/21/2002
Potassium	Metals	63500	µG/L	PDIF03TFXX3X	5/21/2002
Sodium	Metals	5500000	µG/L	PDIF03TFXX3X	5/21/2002
Tin	Metals	36.4	µG/L	PDIF03TFXX3X	5/21/2002
Zinc	Metals	409	µG/L	PDIF03TFXX3X	5/21/2002
Copper	Metals	78.9	µG/L	PDIF03TFXX3X	5/21/2002
Barium	Metals	85.3	µG/L	PDIU03TUXX0X	4/11/2002
Cobalt	Metals	186	µG/L	PDIF03TFXX3X	5/21/2002
Calcium	Metals	8470	µG/L	PDIU03TUXX0X	4/11/2002
Chromium	Metals	30.2	µG/L	PDIU03TUXX0X	4/11/2002
Cobalt	Metals	110	µG/L	PDIU03TUXX0X	4/11/2002
Copper	Metals	215	µG/L	PDIU03TUXX0X	4/11/2002
Iron	Metals	9270	µG/L	PDIU03TUXX0X	4/11/2002
Lead	Metals	143	µG/L	PDIU03TUXX0X	4/11/2002
Magnesium	Metals	7900	µG/L	PDIU03TUXX0X	4/11/2002
Manganese	Metals	950	µG/L	PDIU03TUXX0X	4/11/2002
Molybdenum	Metals	90.6	µG/L	PDIU03TUXX0X	4/11/2002
Aluminum	Metals	883	µG/L	PDIU03TUXX0X	4/11/2002
Molybdenum	Metals	91.6	µG/L	PDIF03TFXX0X	4/11/2002
Aluminum	Metals	1010	µG/L	PDIF03TFXX0X	4/11/2002
Arsenic	Metals	98.1	µG/L	PDIF03TFXX0X	4/11/2002
Barium	Metals	161	µG/L	PDIF03TFXX0X	4/11/2002
Calcium	Metals	8790	µG/L	PDIF03TFXX0X	4/11/2002
Chromium	Metals	45.3	µG/L	PDIF03TFXX0X	4/11/2002
Cobalt	Metals	173	µG/L	PDIF03TFXX0X	4/11/2002
Copper	Metals	92.4	µG/L	PDIF03TFXX0X	4/11/2002
Iron	Metals	2130	µG/L	PDIF03TFXX0X	4/11/2002

Compound	Method Name	Result	Units	Sample ID	Sample Date
Lead	Metals	46	µG/L	PDIF03TFXX0X	4/11/2002
Iron	Metals	2210	µG/L	PDIF03TFXX3X	5/21/2002
Manganese	Metals	928	µG/L	PDIF03TFXX0X	4/11/2002
Cadmium	Metals	85.8	µG/L	PDIU03TUXX0X	4/11/2002
Nickel	Metals	27.6	µG/L	PDIF03TFXX0X	4/11/2002
Potassium	Metals	63000	µG/L	PDIF03TFXX0X	4/11/2002
Sodium	Metals	994000	µG/L	PDIF03TFXX0X	4/11/2002
Zinc	Metals	281	µG/L	PDIF03TFXX0X	4/11/2002
Aluminum	Metals	903	µG/L	PDIF03TFXX3X	5/21/2002
Arsenic	Metals	88.7	µG/L	PDIF03TFXX3X	5/21/2002
Barium	Metals	331	µG/L	PDIF03TFXX3X	5/21/2002
Calcium	Metals	10300	µG/L	PDIF03TFXX3X	5/21/2002
Chromium	Metals	54.6	µG/L	PDIF03TFXX3X	5/21/2002
Magnesium	Metals	7290	µG/L	PDIF03TFXX0X	4/11/2002
Magnesium	Metals	11200	µG/L	PDIU03TUXX3X	5/21/2002
Arsenic	Metals	58.4	µG/L	PDIU03TUXX0X	4/11/2002
Silver	Metals	142	µG/L	PDIU03TUXX0X	4/11/2002
Zinc	Metals	629	µG/L	PDIU03TUXX3X	5/21/2002
Tin	Metals	41.6	µG/L	PDIU03TUXX3X	5/21/2002
Sodium	Metals	5200000	µG/L	PDIU03TUXX3X	5/21/2002
Silver	Metals	473	µG/L	PDIU03TUXX3X	5/21/2002
Potassium	Metals	45500	µG/L	PDIU03TUXX3X	5/21/2002
Nickel	Metals	63.6	µG/L	PDIU03TUXX3X	5/21/2002
Manganese	Metals	1460	µG/L	PDIU03TUXX3X	5/21/2002
Lead	Metals	257	µG/L	PDIU03TUXX3X	5/21/2002
Iron	Metals	28500	µG/L	PDIU03TUXX3X	5/21/2002
Copper	Metals	294	µG/L	PDIU03TUXX3X	5/21/2002
Cobalt	Metals	173	µG/L	PDIU03TUXX3X	5/21/2002
Chromium	Metals	45.7	µG/L	PDIU03TUXX3X	5/21/2002
Barium	Metals	149	µG/L	PDIU03TUXX3X	5/21/2002

Compound	Method Name	Result	Units	Sample ID	Sample Date
Sodium	Metals	870000	µG/L	PDIU03TUXX0X	4/11/2002
Molybdenum	Metals	76.4	µG/L	PDIU03TUXX3X	5/21/2002
Aluminum	Metals	416	µG/L	PDIU03TUXX3X	5/21/2002
Tin	Metals	53.5	µG/L	PDIU03TUXX0X	4/11/2002
Arsenic	Metals	87	µG/L	PDIU03TUXX3X	5/21/2002
Zinc	Metals	305	µG/L	PDIU03TUXX0X	4/11/2002
Cadmium	Metals	169	µG/L	PDIU03TUXX3X	5/21/2002
Calcium	Metals	13000	µG/L	PDIU03TUXX3X	5/21/2002
bis(2-Ethylhexyl) phthalate	SVOC	11	µG/L	PDIU03TUXX0F	3/21/2002
Dithiane	Thiodiglycol (ACT016)	5.046	µG/L	PDIU03TU06CX	5/21/2002
Dithiane	Thiodiglycol (ACT016)	4.417	µG/L	PDIU03TU06BX	5/16/2002
Dithiane	Thiodiglycol (ACT016)	4.222	µG/L	PDIU03TU06AX	5/14/2002
Dithiane	Thiodiglycol (ACT016)	13.87	µG/L	PDIF03TF06BX	5/16/2002
THIOX	Thiodiglycol (ACT016)	3.216	µG/L	PDIF03TF06AX	5/14/2002
Dithiane	Thiodiglycol (ACT016)	16	µG/L	PDIF03TF06AX	5/14/2002
Dithiane	Thiodiglycol (ACT016)	19.87	µG/L	PDIU03TU05DX	5/6/2002
Dithiane	Thiodiglycol (ACT016)	20.32	µG/L	PDIU03TU05CX	5/2/2002
Dithiane	Thiodiglycol (ACT016)	25.55	µG/L	PDIF03TF06CX	5/21/2002
Dithiane	Thiodiglycol (ACT016)	25.1	µG/L	PDIF03TF05DX	5/6/2002
THIOX	Thiodiglycol (ACT016)	2.949	µG/L	PDIF03TF05CX	5/2/2002
Dithiane	Thiodiglycol (ACT016)	3.58	µG/L	PDIF03TF04CX	4/15/2002
Dithiane	Thiodiglycol (ACT016)	18.52	µG/L	PDIF03TF04DX	4/18/2002
Dithiane	Thiodiglycol (ACT016)	20.13	µG/L	PDIF03TF05AX	4/24/2002
THIOX	Thiodiglycol (ACT016)	7.172	µG/L	PDIU03TU05BX	4/26/2002
Dithiane	Thiodiglycol (ACT016)	4.32	µG/L	PDIU03TU03CX	4/2/2002
Dithiane	Thiodiglycol (ACT016)	21.48	µG/L	PDIF03TF05BD	4/26/2002
THIOX	Thiodiglycol (ACT016)	1.92	µG/L	PDIF03TF05BD	4/26/2002
THIOX	Thiodiglycol (ACT016)	2.152	µG/L	PDIF03TF05BX	4/26/2002
Dithiane	Thiodiglycol (ACT016)	24.52	µG/L	PDIF03TF05BX	4/26/2002

Compound	Method Name	Result	Units	Sample ID	Sample Date
Dithiane	Thiodiglycol (ACT016)	29.81	µG/L	PDIF03TF05CX	5/2/2002
Dithiane	Thiodiglycol (ACT016)	2.91	µG/L	PDIU03TU03DX	4/5/2002
Dithiane	Thiodiglycol (ACT016)	9.05	µG/L	PDIU03TUXX0X	4/11/2002
Dithiane	Thiodiglycol (ACT016)	26.32	µG/L	PDIU03TUXX2D	4/24/2002
Dithiane	Thiodiglycol (ACT016)	26.71	µG/L	PDIU03TUXX2X	4/24/2002
THIOX	Thiodiglycol (ACT016)	2.656	µG/L	PDIU03TU06CX	5/21/2002
Dithiane	Thiodiglycol (ACT016)	6.49	µG/L	PDIF03TF02DX	3/25/2002
THIOX	Thiodiglycol (ACT016)	6.592	µG/L	PDIF03TFXX3X	5/21/2002
Dithiane	Thiodiglycol (ACT016)	59.81	µG/L	PDIF03TFXX3X	5/21/2002
Dithiane	Thiodiglycol (ACT016)	19.55	µG/L	PDIU03TUXX3X	5/21/2002
Dithiane	Thiodiglycol (ACT016)	31.61	µG/L	PDIF03TFXX0X	4/11/2002
Dithiane	Thiodiglycol (ACT016)	31.48	µG/L	PDIF03TFXX2X	4/24/2002
Dithiane	Thiodiglycol (ACT016)	47.61	µG/L	PDIU03TU05BX	4/26/2002
Dithiane	Thiodiglycol (ACT016)	4.291	µG/L	PDIU03TU04AX	4/9/2002
Dithiane	Thiodiglycol (ACT016)	7.46	µG/L	PDIU03TU04BX	4/11/2002
Dithiane	Thiodiglycol (ACT016)	19.94	µG/L	PDIU03TU04CX	4/15/2002
Dithiane	Thiodiglycol (ACT016)	32.65	µG/L	PDIU03TU04DX	4/18/2002
Dithiane	Thiodiglycol (ACT016)	41.61	µG/L	PDIU03TU05AX	4/24/2002
THIOX	Thiodiglycol (ACT016)	4.72	µG/L	PDIU03TU05AX	4/24/2002
Dithiane	Thiodiglycol (ACT016)	47.1	µG/L	PDIU03TU05BD	4/26/2002
THIOX	Thiodiglycol (ACT016)	4.08	µG/L	PDIU03TU05BD	4/26/2002
Dithiane	Thiodiglycol (ACT016)	2.474	µG/L	PDIU03TU03AX	3/27/2002
Chloroform	VOC	20	µG/L	PDIF03TFXX0T	4/12/2002

APPENDIX M

ANALYSIS OF THE FEED SOLIDS

Compound Name	Method Name	Result	Units	Qualifier 1	Sample ID	Sample Date
Barium	TCLP (Metals)	0.0526	MG/L		PDIF21TFXX0X	5/21/2002
Cadmium	TCLP (Metals)	0.012	MG/L	J	PDIF21TFXX0X	5/21/2002
Chromium	TCLP (Metals)	0.045	MG/L	J	PDIF21TFXX0X	5/21/2002
Lead	TCLP (Metals)	0.03	MG/L	U	PDIF21TFXX0X	5/21/2002
Mercury	TCLP (Metals)	0.001	MG/L	U	PDIF21TFXX0X	5/21/2002
Selenium	TCLP (Metals)	0.04	MG/L	U	PDIF21TFXX0X	5/21/2002
Silver	TCLP (Metals)	0.003	MG/L	U	PDIF21TFXX0X	5/21/2002
Arsenic	TCLP (Metals)	0.448	MG/L		PDIF21TFXX0X	5/21/2002
2,4-Dinitrotoluene	TCLP (SVOC)	0.01	MG/L	U	PDIF21TFXX0X	5/21/2002
2,4,6-Trichlorophenol	TCLP (SVOC)	0.01	MG/L	U	PDIF21TFXX0X	5/21/2002
Pyridine	TCLP (SVOC)	0.015	MG/L	U	PDIF21TFXX0X	5/21/2002
2-Methylphenol	TCLP (SVOC)	0.015	MG/L	U	PDIF21TFXX0X	5/21/2002
4-Methylphenol	TCLP (SVOC)	0.015	MG/L	U	PDIF21TFXX0X	5/21/2002
Hexachlorobenzene	TCLP (SVOC)	0.005	MG/L	U	PDIF21TFXX0X	5/21/2002
Hexachlorobutadiene	TCLP (SVOC)	0.01	MG/L	U	PDIF21TFXX0X	5/21/2002
Hexachloroethane	TCLP (SVOC)	0.01	MG/L	U	PDIF21TFXX0X	5/21/2002
Nitrobenzene	TCLP (SVOC)	0.01	MG/L	U	PDIF21TFXX0X	5/21/2002
Pentachlorophenol	TCLP (SVOC)	0.015	MG/L	U	PDIF21TFXX0X	5/21/2002
2,4,5-Trichlorophenol	TCLP (SVOC)	0.015	MG/L	U	PDIF21TFXX0X	5/21/2002

Blank

APPENDIX N

POSITIVE RESULTS FOR THE BIOFEED CHARACTERIZATION

Sample Point	Company Name	Method Name	Result	Units	Sample ID	Sample Date
Biofeed	Mercury	Mercury (3.8% HD Mod)	1.43	µG/L	PDIU01TUXX0X	3/21/2002
Biofeed	Iron	Metals (3.8% HD Mod)	133000	µG/L	PDIU01TUXX3X	5/21/2002
Biofeed	Tin	Metals (3.8% HD Mod)	110	µG/L	PDIU01TUXX3X	5/21/2002
Biofeed	Sodium	Metals (3.8% HD Mod)	3690000	µG/L	PDIU01TUXX3X	5/21/2002
Biofeed	Silver	Metals (3.8% HD Mod)	2200	µG/L	PDIU01TUXX3X	5/21/2002
Biofeed	Selenium	Metals (3.8% HD Mod)	30.1	µG/L	PDIU01TUXX3X	5/21/2002
Biofeed	Potassium	Metals (3.8% HD Mod)	53500	µG/L	PDIU01TUXX3X	5/21/2002
Biofeed	Molybdenum	Metals (3.8% HD Mod)	78.8	µG/L	PDIU01TUXX3X	5/21/2002
Biofeed	Zinc	Metals (3.8% HD Mod)	1530	µG/L	PDIU01TUXX3X	5/21/2002
Biofeed	Lead	Metals (3.8% HD Mod)	1200	µG/L	PDIU01TUXX3X	5/21/2002
Biofeed	Nickel	Metals (3.8% HD Mod)	121	µG/L	PDIU01TUXX3X	5/21/2002
Biofeed	Copper	Metals (3.8% HD Mod)	1510	µG/L	PDIU01TUXX3X	5/21/2002
Biofeed	Cobalt	Metals (3.8% HD Mod)	327	µG/L	PDIU01TUXX3X	5/21/2002
Biofeed	Chromium	Metals (3.8% HD Mod)	108	µG/L	PDIU01TUXX3X	5/21/2002
Biofeed	Calcium	Metals (3.8% HD Mod)	14200	µG/L	PDIU01TUXX3X	5/21/2002
Biofeed	Cadmium	Metals (3.8% HD Mod)	870	µG/L	PDIU01TUXX3X	5/21/2002
Biofeed	Barium	Metals (3.8% HD Mod)	143	µG/L	PDIU01TUXX3X	5/21/2002
Biofeed	Arsenic	Metals (3.8% HD Mod)	215	µG/L	PDIU01TUXX3X	5/21/2002
Biofeed	Aluminum	Metals (3.8% HD Mod)	1440	µG/L	PDIU01TUXX3X	5/21/2002
Biofeed	Magnesium	Metals (3.8% HD Mod)	13100	µG/L	PDIU01TUXX3X	5/21/2002
Biofeed	Manganese	Metals (3.8% HD Mod)	2840	µG/L	PDIU01TUXX3X	5/21/2002
Biofeed	Iron	Metals (3.8% HD Mod)	39300	µG/L	PDIU01TUXX0X	3/21/2002
Biofeed	Selenium	Metals (3.8% HD Mod)	34	µG/L	PDIU01TUXX0X	3/21/2002
Biofeed	Silver	Metals (3.8% HD Mod)	736	µG/L	PDIU01TUXX0X	3/21/2002
Biofeed	Sodium	Metals (3.8% HD Mod)	3370000	µG/L	PDIU01TUXX0X	3/21/2002
Biofeed	Tin	Metals (3.8% HD Mod)	102	µG/L	PDIU01TUXX0X	3/21/2002
Biofeed	Zinc	Metals (3.8% HD Mod)	727	µG/L	PDIU01TUXX0X	3/21/2002
Biofeed	Nickel	Metals (3.8% HD Mod)	41.8	µG/L	PDIU01TUXX0X	3/21/2002
Biofeed	Molybdenum	Metals (3.8% HD Mod)	89.8	µG/L	PDIU01TUXX0X	3/21/2002
Biofeed	Manganese	Metals (3.8% HD Mod)	1790	µG/L	PDIU01TUXX0X	3/21/2002
Biofeed	Magnesium	Metals (3.8% HD Mod)	8060	µG/L	PDIU01TUXX0X	3/21/2002
Biofeed	Potassium	Metals (3.8% HD Mod)	57600	µG/L	PDIU01TUXX0X	3/21/2002
Biofeed	Lead	Metals (3.8% HD Mod)	411	µG/L	PDIU01TUXX0X	3/21/2002
Biofeed	Copper	Metals (3.8% HD Mod)	1100	µG/L	PDIU01TUXX0X	3/21/2002

Sample Point	Compound Name	Method Name	Result	Units	Sample ID	Sample Date
Biofeed	Cobalt	Metals (3.8% HD Mod)	274	µG/L	PDIU01TUXX0X	3/21/2002
Biofeed	Aluminum	Metals (3.8% HD Mod)	1090	µG/L	PDIU01TUXX0X	3/21/2002
Biofeed	Chromium	Metals (3.8% HD Mod)	27.8	µG/L	PDIU01TUXX0X	3/21/2002
Biofeed	Calcium	Metals (3.8% HD Mod)	9220	µG/L	PDIU01TUXX0X	3/21/2002
Biofeed	Cadmium	Metals (3.8% HD Mod)	410	µG/L	PDIU01TUXX0X	3/21/2002
Biofeed	Barium	Metals (3.8% HD Mod)	54.2	µG/L	PDIU01TUXX0X	3/21/2002
Biofeed	Arsenic	Metals (3.8% HD Mod)	150	µG/L	PDIU01TUXX0X	3/21/2002
Biofeed	pH	pH (liquid)	10.9	PH UNITS	PDIU01TU06AX	5/14/2002
Biofeed	pH	pH (liquid)	10.24	PH UNITS	PDIU01TU05DX	5/6/2002
Biofeed	pH	pH (liquid)	11.29	PH UNITS	PDIU01TU05AX	4/24/2002
Biofeed	pH	pH (liquid)	11.33	PH UNITS	PDIU01TU04DX	4/18/2002
Biofeed	pH	pH (liquid)	11.54	PH UNITS	PDIU01TU04AX	4/9/2002
Biofeed	pH	pH (liquid)	11.8	PH UNITS	PDIU01TU03DX	4/5/2002
Biofeed	pH	pH (liquid)	11.67	PH UNITS	PDIU01TU03AX	3/27/2002
Biofeed	pH	pH (liquid)	11.4	PH UNITS	PDIU01TU02DX	3/25/2002
Biofeed	pH	pH (liquid)	11.46	PH UNITS	PDIU01TU02AX	3/13/2002
Biofeed	pH	pH (liquid)	9.86	PH UNITS	PDIU01TU01DX	3/7/2002
Biofeed	pH	pH (liquid)	9	PH UNITS	PDIU01TU01AX	2/13/2002
Biofeed	Dithiane	Thiodiglycol (ACT016)	353	µG/L	PDIU01TUXX3X	5/21/2002
Biofeed	THIOX	Thiodiglycol (ACT016)	19.76	µG/L	PDIU01TUXX3X	5/21/2002
Biofeed	Dithiane	Thiodiglycol (ACT016)	178.1	µG/L	PDIU01TUXX2X	4/23/2002
Biofeed	THIOX	Thiodiglycol (ACT016)	10.73	µG/L	PDIU01TUXX2X	4/23/2002
Biofeed	THIOX	Thiodiglycol (ACT016)	9.36	µG/L	PDIU01TUXX0X	3/21/2002
Biofeed	Dithiane	Thiodiglycol (ACT016)	236.4	µG/L	PDIU01TUXX0X	3/21/2002
Biofeed	Dithiane	Thiodiglycol (ACT016)	220.3	µG/L	PDIU01TU06AX	5/14/2002
Biofeed	THIOX	Thiodiglycol (ACT016)	9.687	µG/L	PDIU01TU06AX	5/14/2002
Biofeed	Dithiane	Thiodiglycol (ACT016)	200	µG/L	PDIU01TU05DX	5/6/2002
Biofeed	THIOX	Thiodiglycol (ACT016)	8.88	µG/L	PDIU01TU05DX	5/6/2002
Biofeed	THIOX	Thiodiglycol (ACT016)	10.81	µG/L	PDIU01TU05AX	4/24/2002
Biofeed	Dithiane	Thiodiglycol (ACT016)	206.5	µG/L	PDIU01TU05AX	4/24/2002
Biofeed	THIOX	Thiodiglycol (ACT016)	15.16	µG/L	PDIU01TU04DX	4/18/2002
Biofeed	Dithiane	Thiodiglycol (ACT016)	156.1	µG/L	PDIU01TU04DX	4/18/2002
Biofeed	THIOX	Thiodiglycol (ACT016)	14.4	µG/L	PDIU01TU04AX	4/9/2002
Biofeed	Dithiane	Thiodiglycol (ACT016)	187.4	µG/L	PDIU01TU04AX	4/9/2002
Biofeed	Dithiane	Thiodiglycol (ACT016)	291.3	µG/L	PDIU01TU03DX	4/5/2002
Biofeed	THIOX	Thiodiglycol (ACT016)	10.16	µG/L	PDIU01TU03AX	3/27/2002
Biofeed	Dithiane	Thiodiglycol (ACT016)	258.7	µG/L	PDIU01TU03AX	3/27/2002
Biofeed	THIOX	Thiodiglycol (ACT016)	9.68	µG/L	PDIU01TU02DX	3/25/2002
Biofeed	Dithiane	Thiodiglycol (ACT016)	278.1	µG/L	PDIU01TU02DX	3/25/2002
Biofeed	Dithiane	Thiodiglycol (ACT016)	141.9	µG/L	PDIU01TU02AX	3/13/2002
Biofeed	THIOX	Thiodiglycol (ACT016)	5.81	µG/L	PDIU01TU02AX	3/13/2002