



## A Probability Tree Applied to a Common Zebra Mussel Dispersal Issue

by Barry S. Payne and Andrew C. Miller

**PURPOSE:** The purpose of this technical note is to show how a probability tree can be used to structure consideration of uncertainties surrounding zebra mussel dispersal. Probability trees are diagrammatic tools often used as part of formal decision analysis (Clemens and Reilly 2001). This particular tree considers uncertainties about the spread of zebra mussels to Bayou Bartholomew in light of existing data and knowledge concerning the physiological ecology of the species. This specific example is a useful model for similar projects involving potential spread of an invasive species. Probability trees help structure the consideration of uncertainty, communicate information and assumptions, and thus provide a tractable analysis.

**INTRODUCTION:** The zebra mussel (*Dreissena polymorpha*) (Figure 1) is widely dispersed in the United States in the Midwest and parts of the Northeast but is much less common south of Kentucky. In southern states this species is essentially limited to the Arkansas and lower Mississippi Rivers. One potential pathway for wider dispersal is augmentation of flow in smaller agricultural drainage basins by water withdrawals from large rivers.

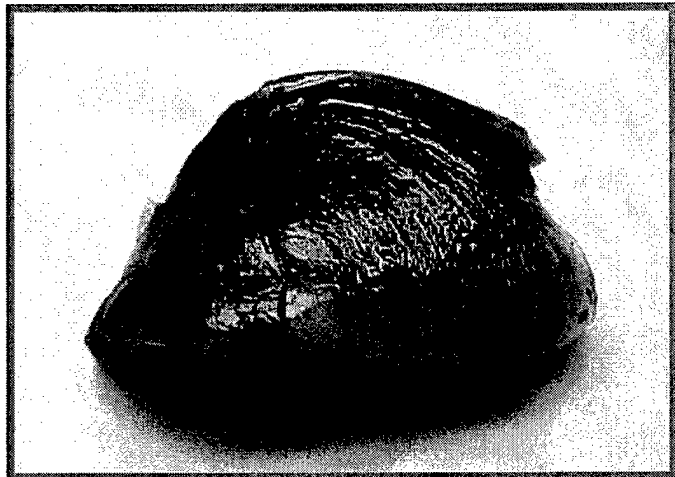

Figure 1. Zebra mussel (*Dreissena polymorpha*)

An example of such a potential pathway is a proposal to pump water from the Arkansas River (through an intake at Pine Bluff, Arkansas) into Bayou Bartholomew, a tributary of the Ouachita River. Augmentation of low flow is part of the proposed Southeast Arkansas Irrigation/Flood Control Project, and would potentially benefit aquatic habitat and support irrigation of extensive rice and soybean plantings. In 2003, the Vicksburg District of the U.S. Army Corps of Engineers was asked by the U.S. Fish and Wildlife Service (USFWS) to address potential zebra mussel range expansion associated with this project. USFWS biologists were concerned that zebra mussels, if introduced into Bayou Bartholomew, could negatively affect native freshwater mussels (Family: Unionidae) and other aquatic resources.

**ZEBRA MUSSEL BIOLOGY:** *Dreissena polymorpha* is a byssate freshwater bivalve native to the Ponto-Caspian region of Europe that was accidentally introduced into the Great Lakes in the mid-1980's and since has rapidly spread throughout the Great Lakes and the Ohio and Mississippi Rivers and their major tributaries (New York Sea Grant 2003). This pest species caused substantial economic (principally as a filter and pipe clogger) and ecological damage. An important ecological

20040617 092

effect has been intensive infestation of native mussel shells, resulting in smothering or starvation of the native bivalves (e.g., Schloesser and Nalepa (1994)).

The species is limited in its southerly distribution in the United States by summer and early fall water temperatures that tend to be near or just above its upper incipient lethal limit of approximately 30 °C (Aldridge et al. 1995, Claudi and Mackie 1994, Hernandez et al. 1995). Although the zebra mussel has successfully invaded the Arkansas River (probably having been brought upstream by barge traffic), population density generally is low but can be high in years with unusually cool summers (Baker et al. 2000). In the lower Mississippi River, Allen et al. (1999) observed mid-summer depression of growth and high mortality when temperatures ranged from 29 to 30 °C for three months (see also Schneider (1992)). Certainly, stressfully high water temperatures have prevented zebra mussels from sustaining dense populations in the South. In the Atchafalaya Basin, low density populations have managed to survive in the mainstem river; connected aquatic habitat in the floodplain is occasionally colonized but unable to sustain even low-density populations over the summer (Battle et al. 1997).

A planktonic veliger larva characterizes the early life history of the zebra mussel; this life stage poses the greatest threat for pump-transport from one river basin to another. This larval stage, common among marine bivalves, is represented in freshwater bivalves only by dreissenids. All native freshwater North American bivalves have developed other early life history stages that avoid being swept downstream. These veligers live in the plankton for 2 or 3 weeks.

Zebra mussels live their post-settlement life attached to firm substratum (shells, cobble, rock, large woody debris, etc.). Like most byssate marine bivalves, attached life implies tolerance of turbulence (e.g., wave wash in littoral and shallow sublittoral zones). Turbulent habitats tend to be well-oxygenated. Low dissolved oxygen probably prevents zebra mussels from surviving in sluggish bayous, ponds, and small lakes where diurnal and seasonal sags in dissolved oxygen concentration often occur (Johnson and McMahon 1998; Matthews and McMahon 1999).

Physiological and ecological factors indicate that zebra mussels are highly unlikely to thrive or perhaps even survive single summers in small streams and rivers in the southeastern United States. Limited dispersal in the South is clearly indicated by the North American distribution maps of this species (New York Sea Grant 2003). Using existing data and knowledge, the likelihood of dispersal of zebra mussels into small and medium southern streams might be best described through development of probability trees. Therefore, the probability tree presented herein shows how to structure consideration of uncertainties about pump-mediated dispersal of zebra mussels. The tree is intended as a template, not a final evaluation. The probabilities in this example were developed from expert opinion and critical review of some of the most pertinent published studies. However, a larger team of experts and a more comprehensive evaluation might result in changes to some of the assigned probabilities.

**OVERVIEW OF A PROBABILITY TREE.** A probability tree is a diagrammatic representation of uncertainty involved in a decision or process. Simple rules guide the construction of a probability tree. First, two or more branches (options) arise from each node in a tree, and only one branch can be taken. Furthermore, the branches are mutually exclusive and collectively exhaustive (i.e., only one outcome can happen and one must happen). Therefore the sum of all branches from a node equals a

probability of 1.0 or 100 percent. In a complicated scenario, with a lot of sequential sources of uncertainty, the number of paths can become quite large. It is useful to imagine nodes as occurring in a time sequence, with the first sources of uncertainty being those to the left (starting side) of the tree.

Outcomes in a sequence are often conditional on a previous event. Consider the simple example of turning over cards, one by one, from a shuffled, single deck. The probability of the first card turned being a nine of any suit is 4/52 (0.0769). Exhausting all other options, there is a 48 in 52 chance (0.9231) that the card is something other than a nine. Obviously, when a second card is turned, the chance of it being a nine is conditional upon the first outcome. If the first card was a nine, then the next card has a 3 in 51 chance (0.0588) of being another nine. If the first card was not a nine, then the chance of the next card being a nine rises to a 4 in 51 chance (0.0784).

A tree representing this simple example is shown in Figure 2. The two branches arising from each chance node (circle) represent the only possible outcomes and their combined probability sums to 1.0 (the additive law of probability). Also, the multiplicative law of probabilities applies to the final outcomes. For example, the probability of turning a pair of nines is 0.00452 (0.0769 times 0.0588).

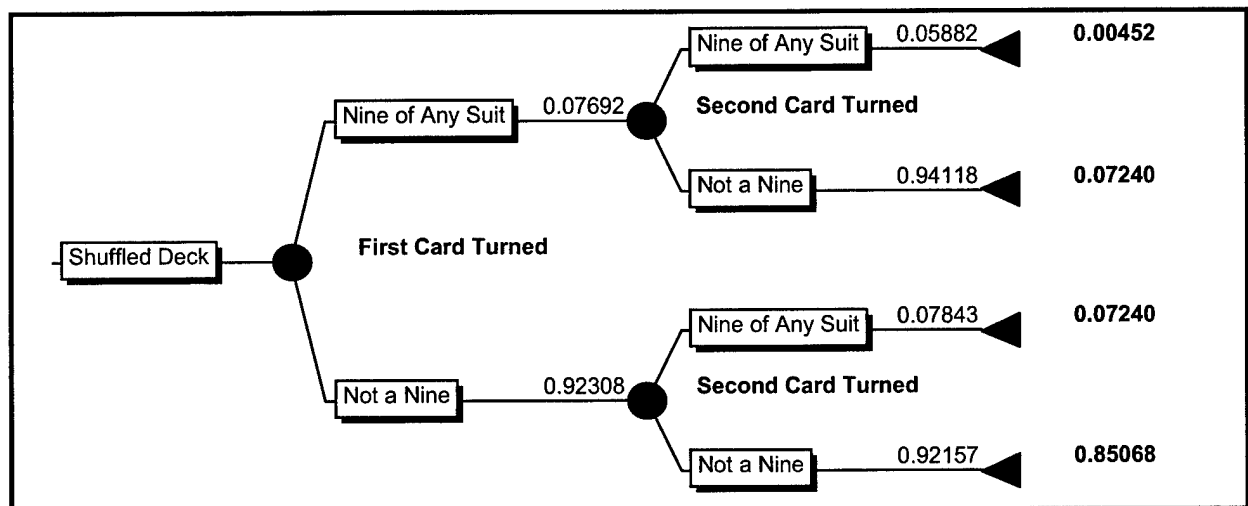

Figure 2. Tree diagramming probability of turning over a nine of any suit as two cards are sequentially turned from a single deck

**PROBABILITY TREES FOR PUMP-MEDIATED DISPERSAL OF ZEBRA MUSSELS.**

Figure 3 is a probability tree that summarizes principal uncertainties in determining if zebra mussels could become successfully established due to pump-mediated dispersal. The entry point for the tree is a decision (represented by the square) to turn the pump on – in spring, summer, winter, or fall. Then, in each season, the three main sources of uncertainty are considered: (a) are healthy veligers available at the pump source in sufficient quantity to support potential spread; (b) will water temperature of the receiving stream remain cool enough to allow a population to successful establish; and, c) will suitably firm substratum for attachment be encountered. More detailed explanations of these factors are as follows:

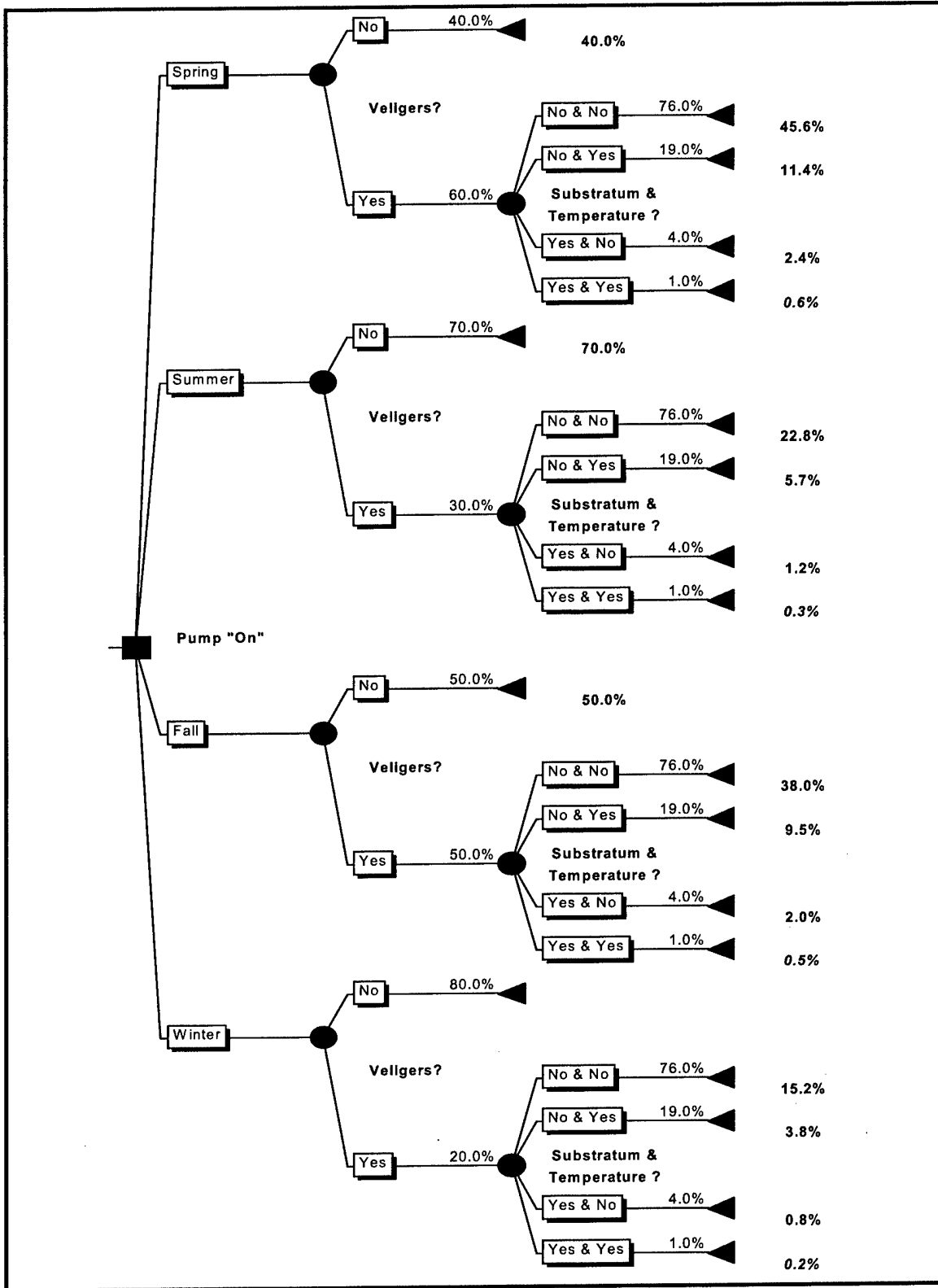

Figure 3. Probability tree for pump-mediated dispersal of zebra mussels

**Probability of a Sufficient Veliger Supply in the Arkansas River.** Zebra mussel reproduction tends to be greatest in spring and fall when water temperature is between approximately 12 and 25 °C, approximately the optimum range for positive bioenergetic balance (Schneider 1992). During warm seasons, reproduction slows or ceases as water temperature approaches 30 °C; the upper lethal limit for adult zebra mussels is slightly above 30 °C (Claudi and Mackie 1994). During late fall and winter, reproduction ceases as temperature falls to less than 12 °C. Variables other than temperature, such as nutritional condition, also affect reproduction but probably without as simple an association as can be made to temperature. Thinking primarily of seasonal temperature patterns, the probability of entraining an adequate supply of veligers in spring, summer, fall, and winter can be estimated. Temperature is more often than not conducive to successful reproduction in the spring and fall, but is mostly too warm in the summer and too cold in the winter. Thus, until a more detailed consideration is made of actual Arkansas River temperature data, probabilities of 0.6, 0.3, 0.5, and 0.2 might be applied to spring, summer, fall, and winter (Figure 3).

**Water Temperature of the Receiving Stream.** Obviously, even under ideal conditions, most veligers do not survive (an individual female is responsible for the production of at least hundreds of thousands of larvae). Introduction into a marginal habitat presents even greater challenges to early survival. Even if a sufficient concentration of healthy veligers are pumped from the source river, those larvae then must encounter conditions in the receiving stream that are suitable for survival for a few years (the average lifespan of a zebra mussel is 1-2 years (Claudi and Mackie 1994)).

Water temperature is a critical variable for subsequent survival of translocated larvae. Bioenergetic stress is likely at temperatures greater than 25 °C (Schneider 1992; Aldridge et al. 1995), and mortality is likely if temperatures greater than 30 °C are sustained for several weeks (Claudi and Mackie 1994; Hernandez et al. 1995).

Temperature of Bayou Bartholomew water is unlikely to often be less than 30 °C during summer and much of the early fall. Only in an exceptionally cool summer is it likely that temperature would remain cool enough for long enough to allow much population establishment. Assuming such a summer condition occurs once per five years (an assumption that could be inspected by a thorough analysis of temperature data), then 0.2 and 0.8 have been used as the probabilities of suitable and unsuitable temperature conditions, respectively.

**Suitably Coarse Substratum for Attachment.** Substratum is generally unsuitable for zebra mussels in the Bayou Bartholomew system. Substratum is predominantly silt and clay (personal observations from extensive field surveys). The principal source of coarse substratum is large woody debris and gravel or cobble-sized particles from road and bridge construction. The probability of encountering suitably firm substratum for attachment is estimated at 0.05 (roughly corresponding to the relative abundance of such substratum). The probability of unsuitable substratum is estimated at 0.95.

**Combined Consideration of Substratum and Temperature.** Zebra mussels will simultaneously require both suitable substratum and temperature to establish a population in Bayou Bartholomew – having one without the other is not sufficient. Thus, instead of sequentially considering these factors in the probability tree, they are combined for consideration. Thus, four branches arise from the

second chance node (circle) in Figure 3. These correspond to outcomes as follows: both substratum and temperature are unsuitable ( $p = 0.95 \cdot 0.8$ ); substratum is unsuitable and temperature is suitable ( $p = 0.95 \cdot 0.2$ ); substratum is suitable and temperature is unsuitable ( $p = 0.05 \cdot 0.8$ ); and, both substratum and temperature are suitable ( $p = 0.05 \cdot 0.2$ ). The only branch allowing successful establishment of population is the last one, when both suitably firm substratum and sufficiently cool water are encountered.

**Seasonal Variation in the Need to Pump Water.** The probability tree in Figure 3 represents the process only after a decision has been made to use the pump in each season. Obviously, there is no chance of pump-mediated dispersal when the pump is not operating. Rainfall and flow augmentation need varies seasonally. In general, pumping is more likely in summer and fall than spring or winter. The pump will be used intermittently, not continuously. It is possible that cooler summers, when successful dispersal of zebra mussels is more likely, will also tend to be wetter summers with reduced pumping demand.

**SUMMARY:** Ultimately, only one pathway in the probability tree for each season results in a chance of successful introduction and establishment. Each successful path requires “yes” answers to the three sequential questions about adequacy of veligers, suitable temperature, and suitable substratum. The probability of each “successful” outcome equals the product of each probability along that path. Similarly, each “no” answer is assigned a probability that is the product of all probabilities along that failed path. The sum of all failed and successful outcomes equals 1.0.

The probability of successful introduction and establishment due to pumping activity is low regardless of seasonal differences in the likelihood of a sufficient supply of veligers occurring at the pump source. Values for the four successful paths equal only 0.6, 0.3, 0.5, and 0.2 percent chances of pump-mediated dispersal due to pump use in spring, summer, fall, and winter, respectively.

This probability tree was built to exemplify a basic tool of decision analysis. The tree suggests a pattern of expectation for the Bayou Bartholomew case. Although spring and fall offer much greater changes than summer and winter for introduction and successful establishment, even in those optimum seasons the chance is very low.

In a larger sense, this example demonstrates the basic construction and use of a probability tree to help guide decisions. Existing data, additional studies, quantitative models, or a combination thereof can improve precision and accuracy of uncertainty analyses. Regardless, use of probability trees with existing information and expert opinion focuses attention on primary factors influencing a process. Better choices can be made and more clearly communicated once critical factors, their dependency structure, and estimated probability values are simply and diagrammatically represented. A probability tree is a useful diagrammatic tool for structuring the consideration and communication of uncertainty.

**POINTS OF CONTACT:** For additional information, contact Dr. Barry Payne, (601)634-3837, Barry.S.Payne@erdc.usace.army.mil, or the manager of the Aquatic Nuisance Species Research Program, Mr. Glenn Rhett, (601)634-3717, Glenn.G.Rhett@erdc.usace.army.mil. This technical note should be cited as follows:

Payne, B. S., and Miller, A. C. (2004). "A probability tree applied to a common zebra mussel dispersal issue," *ANSRP Technical Notes Collection* (ERDC/TN ANSRP-04-1), U.S. Army Engineer Research and Development Center, Vicksburg, MS. <http://www.wes.army.mil/el/ansrp>

## REFERENCES

- Aldridge, D. W., Payne, B. S., and Miller, A. C. (1995). "Oxygen consumption, nitrogenous excretion, and filtration rates of *Dreissena polymorpha* at acclimation temperatures between 20 and 32 °C." *Canadian Journal of Fisheries and Aquatic Sciences*, 52:1761-1768.
- Allen, Y. C., Thompson, B. A., and Ramcharan, C. W. (1999). "Growth and mortality rates of the zebra mussel, *Dreissena polymorpha*, in the lower Mississippi River," *Canadian Journal of Fisheries and Aquatic Sciences*, 56(5): 748-759.
- Baker, W. P., Stoeckel, J. N., and Gagen, C. J. (2000). "Heat-related zebra mussel mortality in Lake Dardanelle, Arkansas." *Joint Meeting of the Arkansas, Louisiana, and Texas Chapters of the American Fisheries Society*, Bossier City, Louisiana, 2000.
- Battle, J. M., Mihuc, T. B., Spiess, F. G., and Bryan, C. F. (1997). "Seasonal colonization dynamics of the zebra mussel *Dreissena polymorpha* in the lower Atchafalaya Basin, Louisiana." *Midyear Meeting of the Southern Division of the American Fisheries Society*, San Antonio Texas, 1997.
- Claudi, R., and Mackie, G. L. (1994). *Practical manual for zebra mussel monitoring and control*. Lewis Publishers, Boca Raton, FL.
- Clemen, R. T., and Reilly, T. (2001). *Making hard decisions with decision tools*. Duxbury Thomas Learning, Pacific Grove, CA.
- Hernandez, M. R., McMahon, R. F., and Dietz, T. H. (1995). "Investigation of Geographic Variation in the Thermal Tolerance of Zebra Mussels, *Dreissena polymorpha*." *Proceedings of the Fifth International Zebra Mussel and Other Aquatic Nuisance Organisms Conference, Toronto, Canada, February 1995*.
- Johnson, P. D., and McMahon, R. F. (1998). "Effects of temperature and chronic hypoxia on survivorship of the zebra mussel (*Dreissena polymorpha*) and Asian clam (*Corbicula fluminea*)." *Canadian Journal of Fisheries and Aquatic Sciences*. 55, 1564-1572.
- Matthews, M. A., and McMahon, R. F. (1999). "Effects of temperature and temperature acclimation on survival of zebra mussels (*Dreissena polymorpha*) and Asian clams (*Corbicula fluminea*) under extreme hypoxia." *Journal of Molluscan Studies* 65, 317-325.
- New York Sea Grant. (2003). "North American Range of the Zebra Mussel as of June 2003," *Aquatic Invaders: The Digest of the National Aquatic Nuisance Species Clearinghouse* 12(2), 12-13.
- Schloesser, D. W., and Nalepa, T. F. (1994). "Dramatic decline of unionid bivalves in offshore waters of western Lake Erie after infestation by the zebra mussel, *Dreissena polymorpha*." *Canadian Journal of Fisheries and Aquatic Sciences* 51, 2234-2242.
- Schneider, D. W. (1992). "A bioenergetic model of zebra mussel, *Dreissena polymorpha*, growth in the Great Lakes," *Canadian Journal of Fisheries and Aquatic Sciences* 49, 1406-1416.

*NOTE: The contents of this technical note are not to be used for advertising, publication, or promotional purposes. Citation of trade names does not constitute an official endorsement or approval of the use of such products.*