

REPORT DOCUMENTATION PAGE

0286

Public reporting burden for this collection of information is estimated to average 1 hour per response, including the time for reviewing and maintaining the data needed, and completing and reviewing the collection of information. Send comments regarding this collection of information, including suggestions for reducing this burden, to Washington Headquarters Services, Directorate for Information Operations and Services, 1215 Jefferson Davis Highway, Suite 1204, Arlington, VA 22202-4302, and to the Office of Management and Budget, Paperwork Reduction Project (0704-0188), Washington, DC 20503.

1. AGENCY USE ONLY (Leave blank)		2. REPORT DATE May 2004	3. REPORT TYPE AND DATES COVERED Final Technical Report 09/15/2002 to 09/14/2003	
4. TITLE AND SUBTITLE Advanced Universal High Temperature Tribometer			5. FUNDING NUMBERS C - F49620-02-C-0100	
6. AUTHOR(S) Hooshang Heshmat, Ph.D.				
7. PERFORMING ORGANIZATION NAME(S) AND ADDRESS(ES) Mohawk Innovative Technology, Inc. 1037 Watervliet-Shaker Road Albany, New York 12204-2033			8. PERFORMING ORGANIZATION REPORT NUMBER 02K02-11-50128	
9. SPONSORING/MONITORING AGENCY NAME(S) AND ADDRESS(ES) USAF, AFRL AF Office of Scientific Research 4015 Wilson Blvd, Room 713 Arlington, VA 22203-1954 NL			10. SPONSORING/MONITORING AGENCY REPORT NUMBER	
11. SUPPLEMENTARY NOTES				
12a. DISTRIBUTION/AVAILABILITY STATEMENT "Distribution Statement A. Approved for public release; distribution is unlimited."			12b. DISTRIBUTION CODE	
13. ABSTRACT (Maximum 200 words) Small, mesoscopic sized steam powered machines are being developed using new materials while operating at high speeds and temperatures in an effort to achieve high efficiencies and power densities. It is imperative that an in-depth understanding of material tribological properties be gained to ensure that the goal of long life and high efficiency are achieved in the developed machinery. Due to the wide range of parameters affecting wear, an advanced tribometer, which accurately models the application environment and operating conditions is needed. The main objective of the high temperature steam tribometer project was to design, build and test a new and advanced tribometer capable of determining friction wear and wear characteristics of various mesoscopic steam engine materials. The specimens installed in the developed tribometer can be tested at surface velocities greater than 50 m/s, under loads to 400 N, while subjected to superheated steam at temperatures to 600C. Metallic or ceramic test specimen discs in from 1 to 4 inch in diameter and ball/pin specimens of 0.25 in in diameter may be used. The computer controls tests and records friction force, environmental conditions and disc speed.				
14. SUBJECT TERMS Tribometer Tribology, Friction, Wear, Ceramic, Lubrication, Steam, Mesoscopic			15. NUMBER OF PAGES 26	
			16. PRICE CODE	
17. SECURITY CLASSIFICATION OF REPORT UNCL	18. SECURITY CLASSIFICATION OF THIS PAGE UNCL	19. SECURITY CLASSIFICATION OF ABSTRACT UNCL	20. LIMITATION OF ABSTRACT Unlimited	

NSN 7540-01-280-5500

Standard Form 298 (Rev. 2-89)
Prescribed by ANSI Std. Z39-18**BEST AVAILABLE COPY**

20040617 056

NOTICE

USING GOVERNMENT DRAWINGS, SPECIFICATIONS OR OTHER DATA INCLUDED IN THIS DOCUMENT FOR ANY PURPOSE OTHER THAN GOVERNMENT PROCUREMENT DOES NOT IN ANY WAY OBLIGATE THE US GOVERNMENT IN ANY WAY. THE FACT THAT THE GOVERNMENT FORMULATED OR SUPPLIED THE DRAWINGS, SPECIFICATIONS OR OTHER DATA DOES NOT LICENSE THE HOLDER OR ANY OTHER PERSON OR CORPORATION; OR CONVEY ANY RIGHTS OR PERMISSION TO MANUFACTURE, USE, OR SELL ANY PATENTED INVENTION THAT MAY RELATE TO THEM

THIS REPORT HAS BEEN REVIEWED AND IS APPROVED FOR PUBLICATION.

REPORT DOCUMENTATION PAGE

ABSTRACT

The operating speeds, loads and temperatures of advanced turbine based rotating machinery have all seen substantial increases during the past twenty-five years in response to demands for improved system efficiencies and performance in smaller packages. Yet the tribology community has maintained, more or less, conventional tribosurface speeds. Recent advancement goals in gas turbine engines and micro/mesoscopic engines have put strenuous demands on tribological materials and extreme environmental operation, such as high speeds (greater than Mach 1), high temperatures (1500°F) and oxidative environments (i.e., steam and other gaseous substances).

New technologies in materials and tribology have the potential to make practical advancements in steam engine applications. Recently, as smaller, mesoscopic sized machines are being developed, new materials are being introduced and higher operating speeds and temperatures are being employed to achieve higher efficiencies, it is imperative that an in-depth understanding of material tribological properties be gained. Relative to mesoscopic steam engine designs and life, tribological testing is essential to achieving the goal of long life efficient machinery. Due to the wide range of parameters affecting wear, what is needed is an advanced tribometer, which accurately models the environment and will permit assessment of selected materials.

The most critical first step in characterizing tribological materials under extreme conditions is the design of a tester that will give meaningful results. This paper documents the key issues addressed during the designing, building and testing of the high temperature, high speed steam tribometer, specifically, the tribomaterial sample and holder installation and alignment, dynamics of the loading device and weight and the measurement system (normal load, friction, and wear rate). This requires careful integration of end item application requirements (frequencies, motions, temperatures and loads), materials selection, thermal management and system dynamic analysis. Tribological results of some initial tests on ceramics, metals and composites with steam lubrication will also be presented.

The main objective of the high temperature steam tribometer project is to design, build and test a new and advanced tribometer that is capable of determining friction wear and wear characteristics of various mesoscopic steam engine materials. This has been broken down into three major tasks:

Task 1 – Design

Task 2 – Fabrication

Task 3 – Documentation

THIS PAGE INTENTIONALLY LEFT BLANK

TABLE OF CONTENTS

ABSTRACT.....	i
TABLE OF CONTENTS.....	iii
LIST OF ILLUSTRATIONS.....	iv
Introduction and Statement of Relevance.....	1
Background.....	4
Program Accomplishments.....	6
Tribometer Requirements and Design.....	6
Tribometer Fabrication.....	14
Final Specifications.....	20

LIST OF ILLUSTRATIONS

Figure 1. Conceptual Sketch of a Mesoscopic Steam Engine	1
Figure 2. Piston ring/cylinder liner set-up	2
Figure 3. Ring Frictional Force and Velocity versus Piston Stroke	3
Figure 4. Examples of engineering tribosystems, test systems and their elementary structure.....	4
Figure 5. Electromagnetic reciprocating slider test rig and diagrammatic instrumentation set-up.....	5
Figure 6. Mechanically driven reciprocating slider test rig and schematic diagram	5
Figure 7. Tribometer with steam generator installed.	8
Figure 8. Cross-section of tribometer	9
Figure 9. Cross section of drive spindle showing high pressure abradable buffer seal ...	10
Figure 10. High pressure abradable seal design.....	11
Figure 11. Pin on disc dynamic model.....	12
Figure 12. Dynamic force magnitude due to disc misalignment.	13
Figure 13. Dynamic force magnitude due to surface waviness.	13
Figure 14 Tribometer set up for high temperature test	15
Figure 15 Tribometer set up for superheated steam.....	16
Figure 16 High Pressure Vessel.....	16
Figure 17 Spindle Housing and Motor Mount.....	17
Figure 18 High Speed Servo Motor	18
Figure 19 Motor Controller and Signal Conditioning System.....	18
Figure 20 Sample Labview screen for monitor and control	19

Introduction and Statement of Relevance

Steam technology dating back to the 19th century has been shown to be effective in both propulsion and power generating systems. They are relatively safe, reliable, robust, water is readily available and they are ecologically sound. As effective as these systems were in early industrialization, they were characterized by low efficiency and large size. Steady increases in efficiency have been made however, with the advent of higher temperature and pressure steam producing systems, better materials and higher speed operation. New materials and designs may permit the development of machines that break current molds and open up new, before unthought of applications. The military is in need of mesoscale electrical sources for the next generation of electronics-dependent mobile forces. The demands for soldier electric power continue to increase with the development of advanced systems, batteries are becoming an increasingly less viable option. For such miniature systems small gains in reducing friction losses can have a significant impact on performance.

As smaller machines are developed, new materials introduced and higher operating speeds and temperatures are employed to achieve the desired higher efficiencies, it is imperative that an in-depth understanding of material tribological properties be gained. New technologies in materials and tribology have the potential to make practical a revolutionary steam engine concept, which can significantly exceed the power density of any prior steam systems. Figure 1 shows a conceptual design of a mesoscopic steam engine.

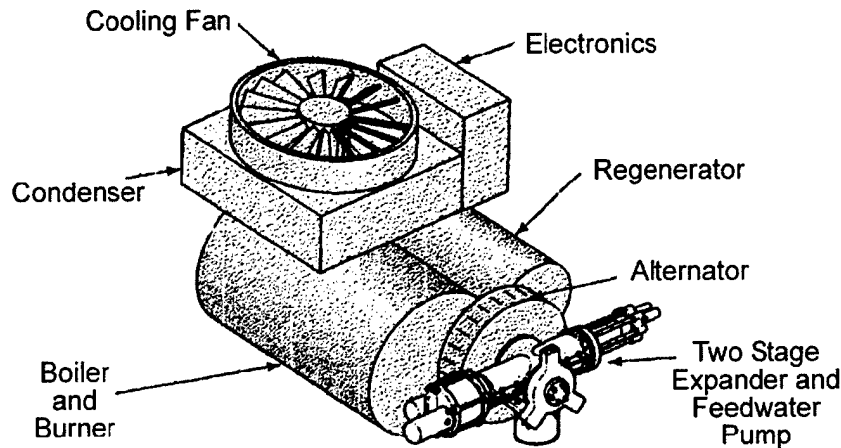

Figure 1. Conceptual Sketch of a Mesoscopic Steam Engine

Recent collaborations with steam engine designers revealed a number of tribological concerns in developing a mesoscopic size engine. Foster-Miller who have direct experience in producing military orientated meso-scale systems from years of work on miniature personnel cooling systems highlighted some major tribological issues in such mesoscopic size steam engines. These included finding tribological components that could provide the desired system life while operating under the thermal cycle conditions that have to be used to achieve the performance goals. Some major areas identified for tribological development were in miniaturizing the components. Discussions with Foster Miller revealed some of the specific concerns with respect to the components in the expander region of the mesoscopic steam engine such as the steam valves, cylinder design and piston rings. For the steam valves the major concerns were identified as surface chemistry effects, gas driven erosion, and adhesive wear but with low interfacial motion. The cylinder design was required to be made from a high temperature alloy, presenting minimal thermal conductance paths to the crankcase. In all cases the cylinder wall, and piston ring materials or

coatings must be tribologically compatible in a hot steam environment. Some of the tribological issues of concern for steam engines are excessive wear over extended periods of operation. The major areas are, the piston rings, cylinder liners, the valves and the engine bearings, see Figure 2.

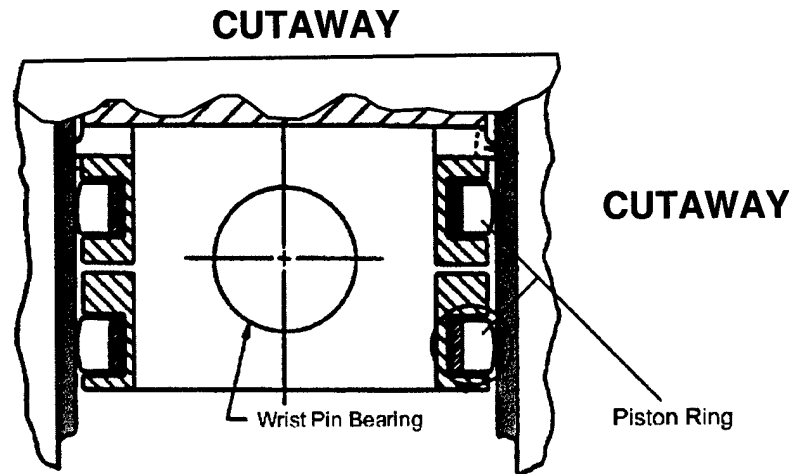

Figure 2. Piston ring/cylinder liner set-up

The wear on the piston rings and liners is due to the high temperatures, high pressures and the surface chemical effects of the steam environment. The piston rings carry most of the load, unlike the gas or diesel engines. For these type of engines the squeeze film term helps to accommodate the side loads, thus the piston rings see much less detrimental wear damage, however in steam engines the squeeze film effects are very low therefore, the majority of the loads are carried by the piston rings/cylinder. The mechanism leading to steam engine wear can be gleaned from Figure 3, which charts the frictional force and ring velocity as functions of piston stroke. During a normal compression cycle, the pressure peaks when the piston is near the top dead center (TDC). On the other hand, ring velocity slows to zero both at TDC and when piston nears bottom dead center (BDC). Maximum velocity value is achieved when the piston is at midstroke. This out of phase variation of ring speed and loading leads to variation in the wear, with maximum wear at TDC. Wear is highest at TDC because of the highest temperatures at that point, thus aggravating ongoing wear. However, even at the BDC, where the loads are low appreciable wear takes place.

Besides wear, subsurface fatigue initiated cracks and subsequent spalling can be an especially important limitation to component life. Even after only a few hours of operation, a particle can spall from the piston ring. Once spalling has occurred further deterioration follows rapidly, due to the fact that the particles from such a fatigue wear process are characteristically much larger than the very small fragments associated with adhesive or abrasive wear. Wear resulting from spalling typically generates a characteristic "pitted" surface, and is closely related to the general phenomenon of metal fatigue. Changes to the material, or its environment, will usually have an effect on pitting or fatigue wear.

Relative to steam engine designs and life, tribology is essential to achieving the goal of long life efficient machinery. The current art in materials limits the potential of small steam engines and where there are specific opportunities for new technologies to significantly improve the performance and cost. Due to the wide range of parameters affecting wear, what is needed is an advanced tribometer, which accurately models the environment and will permit assessment of selected materials. A suitable machine needs to be made to address this need. Regardless of the system conceived, a key thread through all the systems is the need for higher operating temperatures, pressures, speeds and a reduction in parasitic losses. From the

performance side of things, a better understanding of the friction characteristics of advanced materials is needed if efforts to continually improve efficiency are to be fruitful and in some cases even make the engine designs feasible. The proposed effort was therefore directed at development of a tribometer to simulate realistic conditions.

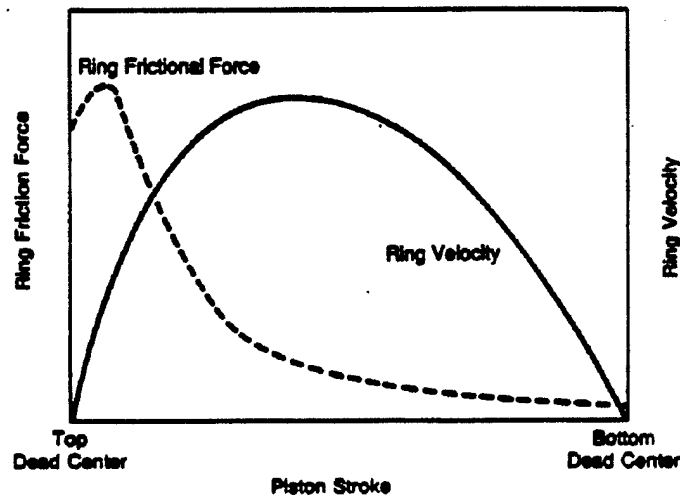

Figure 3. Ring Frictional Force and Velocity versus Piston Stroke

The operating speeds, loads and temperatures of advanced turbine based rotating machinery have also seen substantial increases, especially during the past twenty-five years as demands for improved system efficiencies and performance in smaller packages have emerged. Coupled with the performance gains, are requirements for increased life, all of which place strenuous demands on tribological materials given the high surface speeds, high temperatures and oxidative environments (i.e., steam and other gaseous substances). While new materials and designs are surfacing, characterization of their friction and wear properties under realistic conditions is needed. Surprisingly, the fundamental test rigs used by the tribology community to accomplish just such characterizations have remained relatively unchanged since the 1960's.

Given that a new class of mesoscopic sized machines are being developed, using new materials and operating at very high speeds and temperatures, it is imperative that an in-depth understanding of material tribological properties be gained. Relative to mesoscopic steam engine designs and life, tribological testing is essential to achieving the goal of long life efficient machinery. Due to the wide range of parameters affecting wear, what is needed is an advanced tribometer, which accurately models the environment and will permit assessment of selected materials. This report documents the key issues addressed during the designing, building and testing of the high temperature, high speed steam tribometer. Key items described include, the installation and alignment of the samples, dynamics of the loading device, and the measurement system (normal load, friction, and wear rate). Tribological results of some initial tests on ceramics, metals and composites with steam lubrication will also be presented.

Background

In the 1960's the American Society for Lubrication Engineers (ASLE) listed more than 200 types of wear tests and equipment in use [2], and the list has since grown. This wide variety is the result of a desire to ensure appropriate controls and test convenience and the need to simulate wear conditions of the intended application. Most of this equipment includes apparatus specially designed for laboratory use. Although many of the test configurations are one of a kind machines, others are available as commercial units. Typical configurations are illustrated in Figure 4.

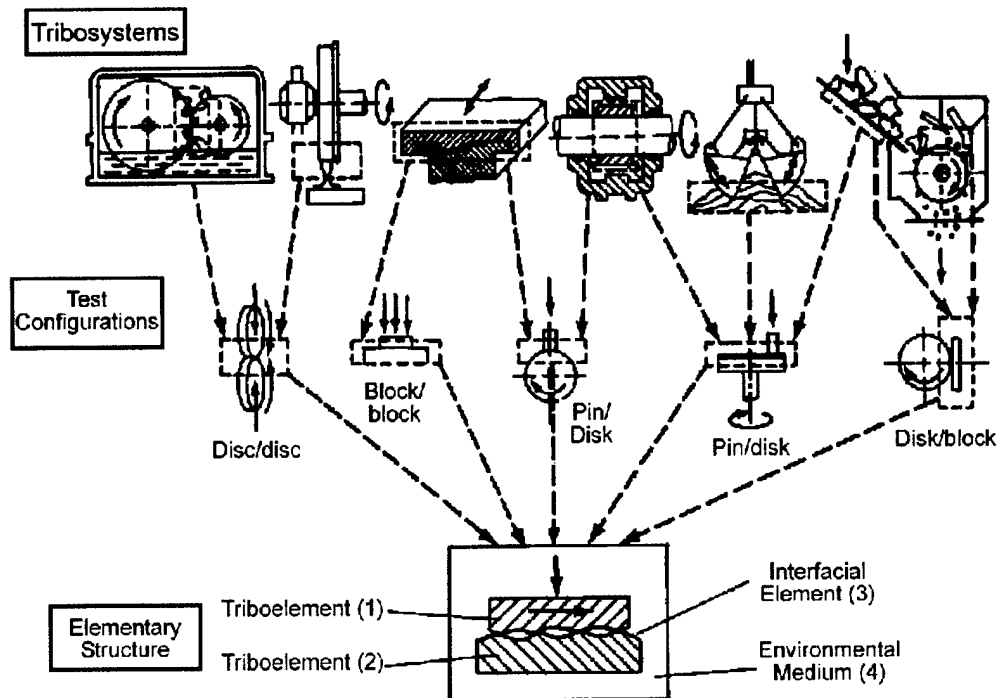
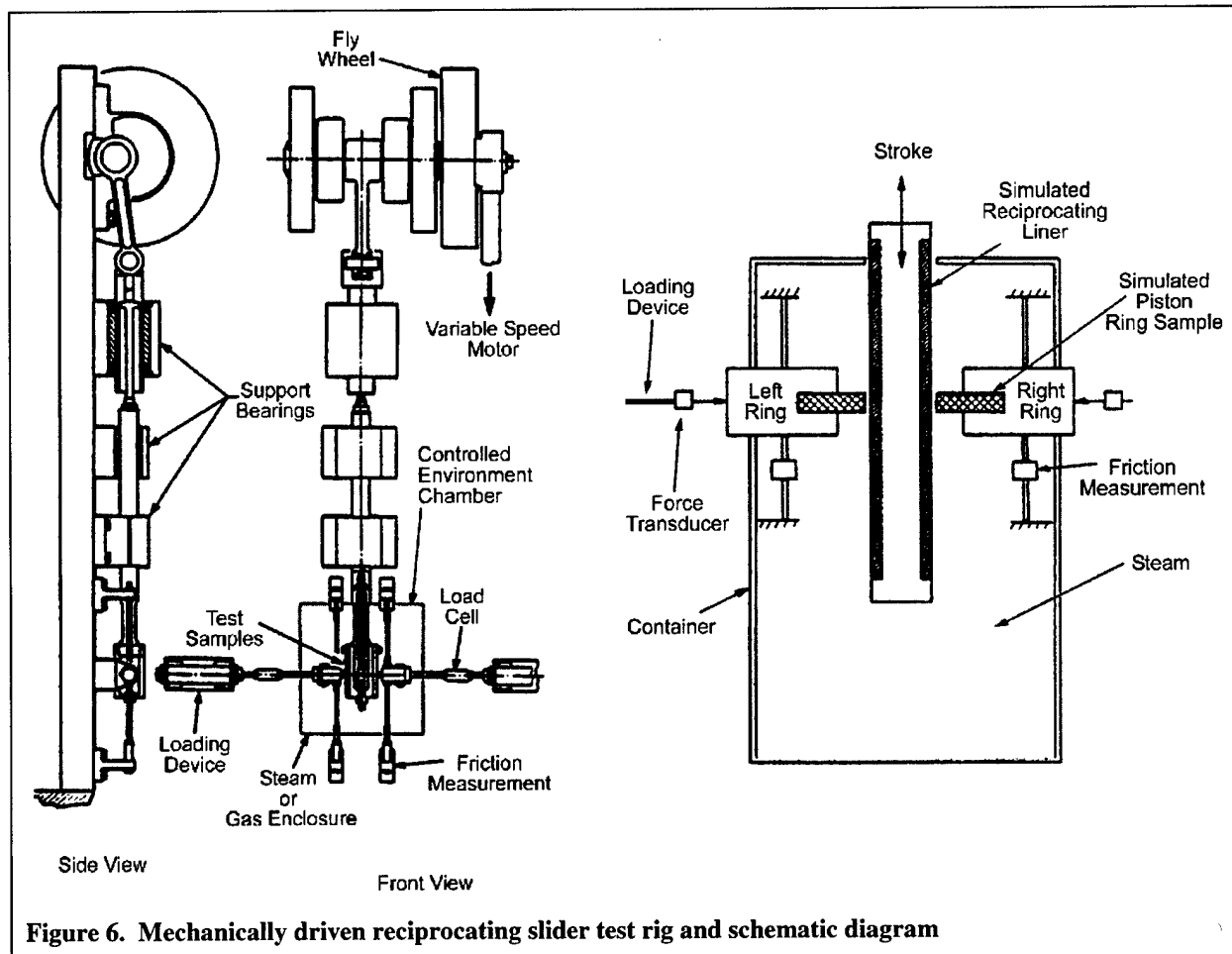
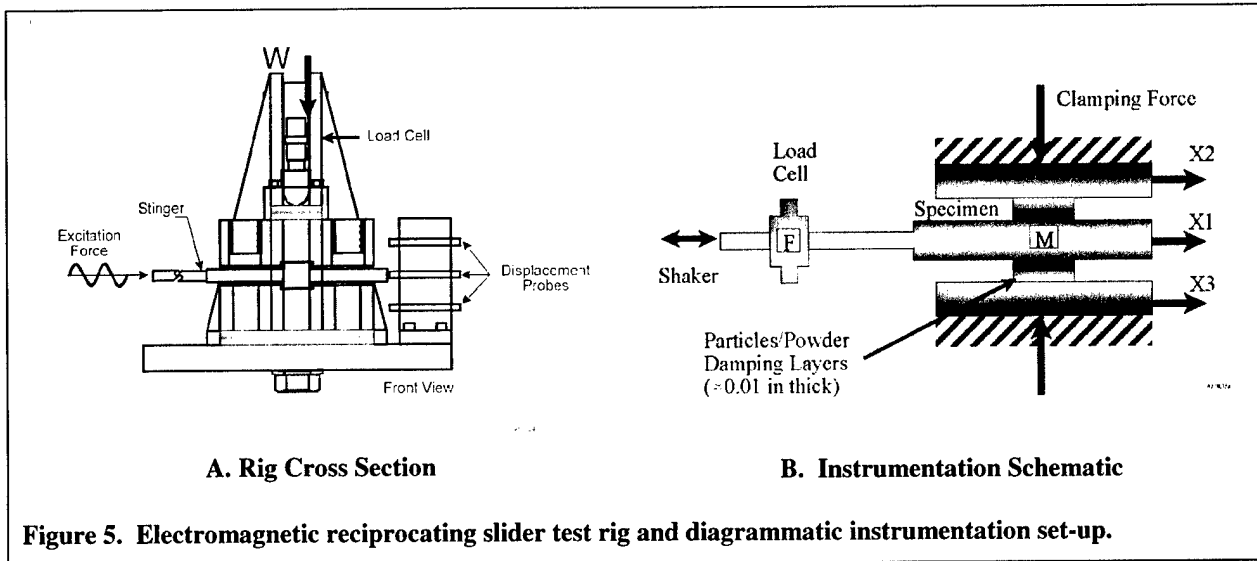

Figure 4. Examples of engineering tribosystems, test systems and their elementary structure.

Currently, the general types of reciprocating test rigs used to conduct tribological tests are shown in Figure 5 and Figure 6. Although both test rigs are reciprocating sliding type rigs they both present very different problems. Figure 5 is an electromagnetic reciprocating slider test rig having two interface surfaces. This test facility was designed to produce high frequency, small amplitude tangential oscillations in a central specimen placed under relatively high normal forces. Tests can be run at temperatures ranging from room temperature condition to 1000°F. The test sample plates are connected to a load cell driven by an electromagnetic system. The total motion can be in the order of 40-50 micro-inches at frequencies up to 2,000Hz. At each frequency the displacements of the tribomaterial test samples can be recorded and also the load cell force. The limitations of this type of test rig are that it has an open environment, and it can be subject to structural dynamic resonant excitations, which can jeopardize results.

A mechanically driven reciprocating slider test rig is shown in Figure 6. This test set-up includes ring and liner specimens simulating their actual mounting in a steam engine. A vertical block reciprocating at 2000cpm and a full stroke of 76.2mm, may be aligned with two piston rings on opposite sides. The test rig records the applied normal loads and the frictional forces that act on

each piston ring. This rig also has temperature capability to 1000°F. While this test rig does overcome some of the advantages of the electromagnetic driven test rig in Figure 5, it is too bulky, its test frequencies, while variable, are limited to 2000 cpm and the stroke length is fixed.



Friction and wear testing is not limited to such equipment alone. Tests often are performed with replicas or facsimiles of actual devices in order to provide more control, increased instrumentation and to provide a high degree of simulation to actual wear conditions. What is unique about continuous friction and wear measurements for mesoscopic engines are that the loads are significantly smaller, amplitudes of motion are much different and the frequencies are higher than those typically tested today. Therefore, a test rig is required which can simulate the test components of a mesoscopic steam engine much more accurately and taking into account any dynamic fluctuations in the test set-up, in order to record highly accurate friction and wear test data for particular tribomaterial combinations in steam environment at high temperatures and pressures.

Program Accomplishments

The design, fabrication and preliminary checkout testing of a high temperature tribometer has been completed. The tribometer, as designed, includes a high speed spindle, a direct drive high speed motor, fixtures that properly align the specimen and provide easy change out of specimens, a counterbalanced torque arm with a ball holder and a pressure dome with an oven and a high pressure superheated steam generator. Prior to completion of the effort, the tribometer was transferred to a parallel DARPA funded effort in order to expand the capabilities of the developed tribometer to incorporate more complex motions.

Tribometer Requirements and Design

The overall motivation for the design of this machine is to achieve the capability to determine the friction and wear of high temperature materials for use in a mesoscopic steam engine. Considerable commercial benefit can be derived from reliable correlative testing specifically in reducing development time for products and in minimizing the cost of testing. A precision tester requires a detailed understanding of the environment being simulated and the careful integration of materials, thermal analysis, and system dynamic analysis. Conventional tribometers have been proven to suffer from shortcomings in accurately simulating operating conditions of advanced systems and in properly controlling the test conditions. Without properly controlled test conditions, the validity of results and conclusions drawn from them come into question. Generally, tribometers are not built to simulate the high speeds and high temperatures in the range for which this tribometer is required. MiTi[®] has already designed and fabricated nine tribometers; one was manufactured for Air Force Research Laboratory' Materials Directorate at Wright Patterson Air Force Base, another for the University of Florida, two for NASA Glenn Research Center and five for research and development investigations at MiTi[®]. This past experience and the review of existing tribometers as shown in Table 1 was used to establish a basic tribometer design that could be used to characterize materials under high temperature and high pressure steam conditions.

The key design factors addressed were temperature, pressure, spindle speed and instrumentation. From these, the following specifications were determined:

- Disk Diameter: 2-4.5 in
- Ball Diameter: 0.25 in
- Spindle speed: 10,000 rpm
- Superheated, high pressure steam: 600°C
- Load: 1-400N
- Contained steam chamber capability: 450 PSI

The design was based on the existing and proven MiTi[®] tribometer noted above. This high temperature tribometer was selected since the spindle had been demonstrated to the desired speed with minimal mechanical run out. It was determined that the major design change required was to add a pressure

vessel, appropriate high pressure seals and a high-output steam generator. Figure 7 shows the tribometer with the steam generator installed. Figure 8 through Figure 10 show the tribometer design including the pressure dome, high-speed spindle, and the high-pressure seal.

Table 1. Tribometer capabilities comparison

Tribometers	Contact	Type of Motion	Load (N)	Sliding Speed (m/s)	Temperature (°C)	Atmosphere
CSEM Pinon Disc	Pin-on Disc	Unidirectional	1-30	2	Ambient	Air/dry nitrogen
CSEM Pinon Disc	Pin-on Disc	Unidirectional	1-60	2	800	Air/dry nitrogen
CameronPlint TE97	Pin-on-Disc	Unidirectional	50-800	9	Ambient	Air
CameronPlint TE77	Ball, cylinder or ring on flat	Reciprocating sliding	5-250	0.37	20 to 250	Air
CameronPlint TE67	Pin-on-disk	Reciprocating sliding	5-1,000	0.05-8	Ambient to 750	Air
BAM-Type HTT	Pin-on-Disc	Unidirectional	1-1000	6	15 to 1000	Air
MiTi HTP 5	Pin-on-Disk	Unidirectional	1-400	30	370	Air
MiTi HTP40	Pin-on-Disk	Unidirectional	1-400	50	750	Air/Nitrogen/Argon
MiTi Steam100	Pin-on-Disc	Unidirectional	1- 400	35	200	Steam
MiTi Steam-600	Pin-on-Disc	Unidirectional	1- 400	35	600	Steam
MiTi HTB- 70	Disk-on disk Pin-on-disk	Unidirectional	1-400	40	650	Air
MiTi HSD70	Disk-on-Disk	Unidirectional	1-400	116	650	Air
MiTi HSR30	Roller-on-Disk	Unidirectional	1-4000	50	650	Air
MiTi HSF80	Hydrodynamic Bearing	Unidirectional	1-1700	130	1000	Air
Angstrom	Pin-on-disk	Unidirectional			500	
Angstrom	Pin-on-disk-or-cylinder	Unidirectional			Ambient	Air
Micro Photonics CSM	Pin-on-disk	Reciprocating sliding	1-60	35	High and Low	Various + Vacuum
Micro Photonics LRT	Pin-on-disk	Reciprocating Sliding	46 Max	0.0001-1	-200 to 600	Air
Falex multi-specimen	Pin-on-disk	Unidirectional			Heated or Cooled	Air/Wet/Dry
Koehler K93513	Pin-on-disk	Unidirectional	1- 200	0.26- 10	Ambient	Air or Environmental Chamber
WazauSST	Pin-on-disk	Unidirectional	1-1,000		Ambient to 380	Air
CETR Micro UMT	Various	Recip/Rotate	1-1,000	0.001-50	Ambient to 150	Air

To keep the size of the pressure vessel dome as small as possible, it was necessary to reduce the size of the torque arm and switch from a small load cell to a harsh environment strain gage. This eliminated the more complex double gimble used in the existing tribometer design with a simpler single axis pivot. The revised specimen load arm allowed the counterweight to be moved closer to the pivot bearing, yielding a small torque arm assembly, while not compromising the quality of the data.

The precision spindle was analyzed to ensure that the critical speeds would not pose a problem for the 10,000 rpm operation and to determine the manufacturing tolerances for test specimen alignment and flatness. From the preliminary rotor dynamic analysis it was determined that the rigid body critical speeds occurred at approximately 7050, and 31450 rpm respectively. Since the maximum rotational design speed is 10,000 rpm, the primary concern will be traversing the first mode. Control of the first rigid body critical speed, a conical mode, should be readily accomplished with a small amount of damping at each bearing. The second critical speed is well above the design speed of 10,000 rpm.

Figure 11 presents the dynamic model used to analyze and establish required assembly tolerances for the tribometer. Figure 12 shows the impact of disc misalignment on dynamic forces as speed is increased to the design speed of 10,000 rpm. Based on this analysis and an effort to keep dynamic forces less than 1-pound, disc runout must be maintained at or less than 0.0001 inch (2.54 micron). Similarly, as shown in Figure 13, surface flatness of less than 0.0001 inch (2.54 micron) is also desired. Since the spindle design used as the basis for this tribometer has already demonstrated a runout equal to or better than

needed it was decided that this spindle design would suffice for this effort.

At the same time the spindle housing and bearings spacers were simplified to make assembly of the spindle more repeatable and operation more reliable. To achieve the simplification part drawings were reviewed and where possible individual components combined to reduce parts. Materials were also changed to be compatible with superheated steam. Due to the addition of high pressure steam, a buffered abrazeable seal was added to seal the high pressure steam in the vessel. Finally, a direct drive motor with an electronic servo driver was selected to provide smoother operation and allow computer control of spindle speed was added to the system.

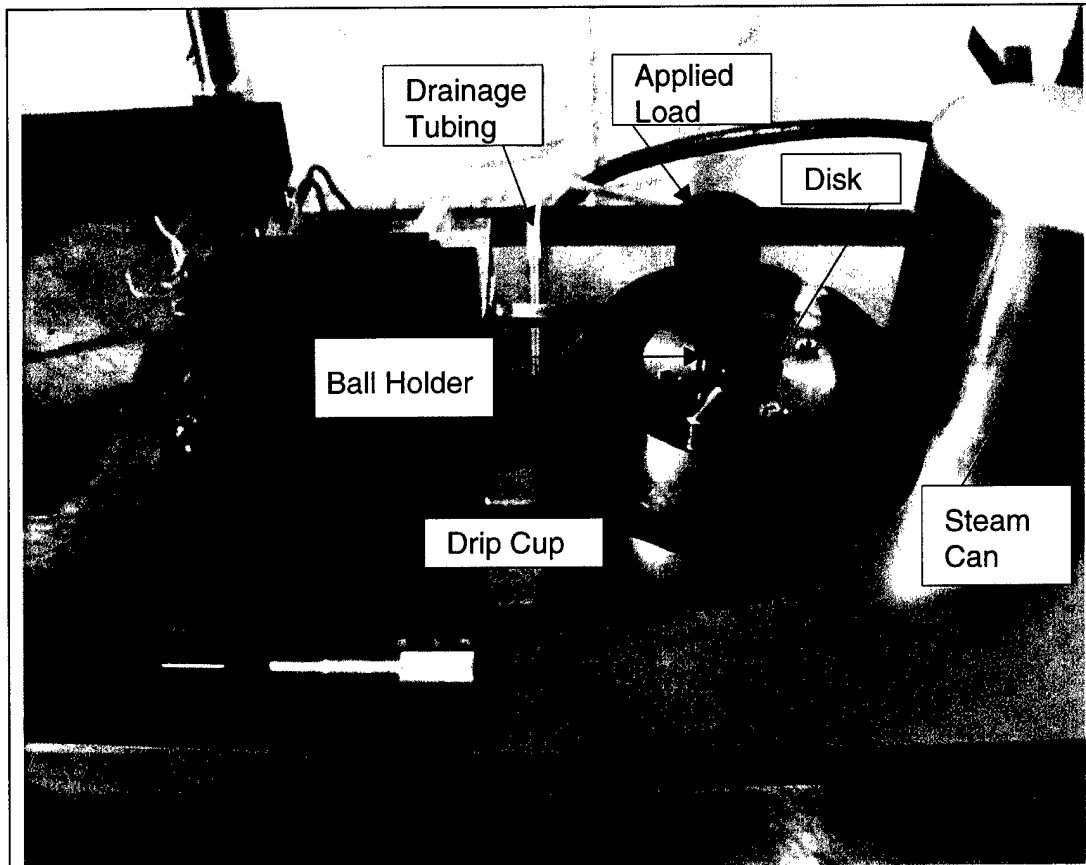
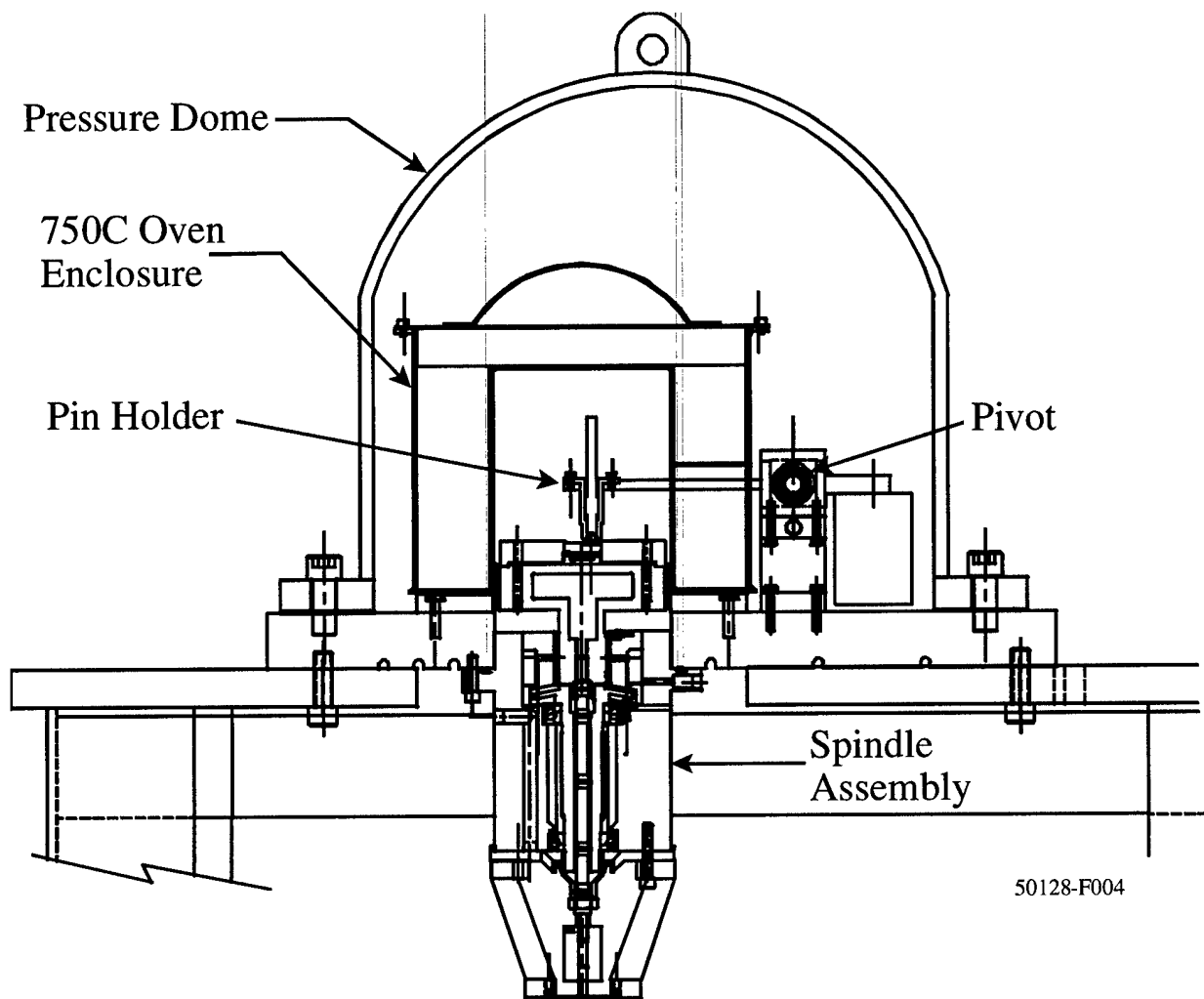

Figure 7. Tribometer with steam generator installed.



50128-F004

Figure 8. Cross-section of tribometer

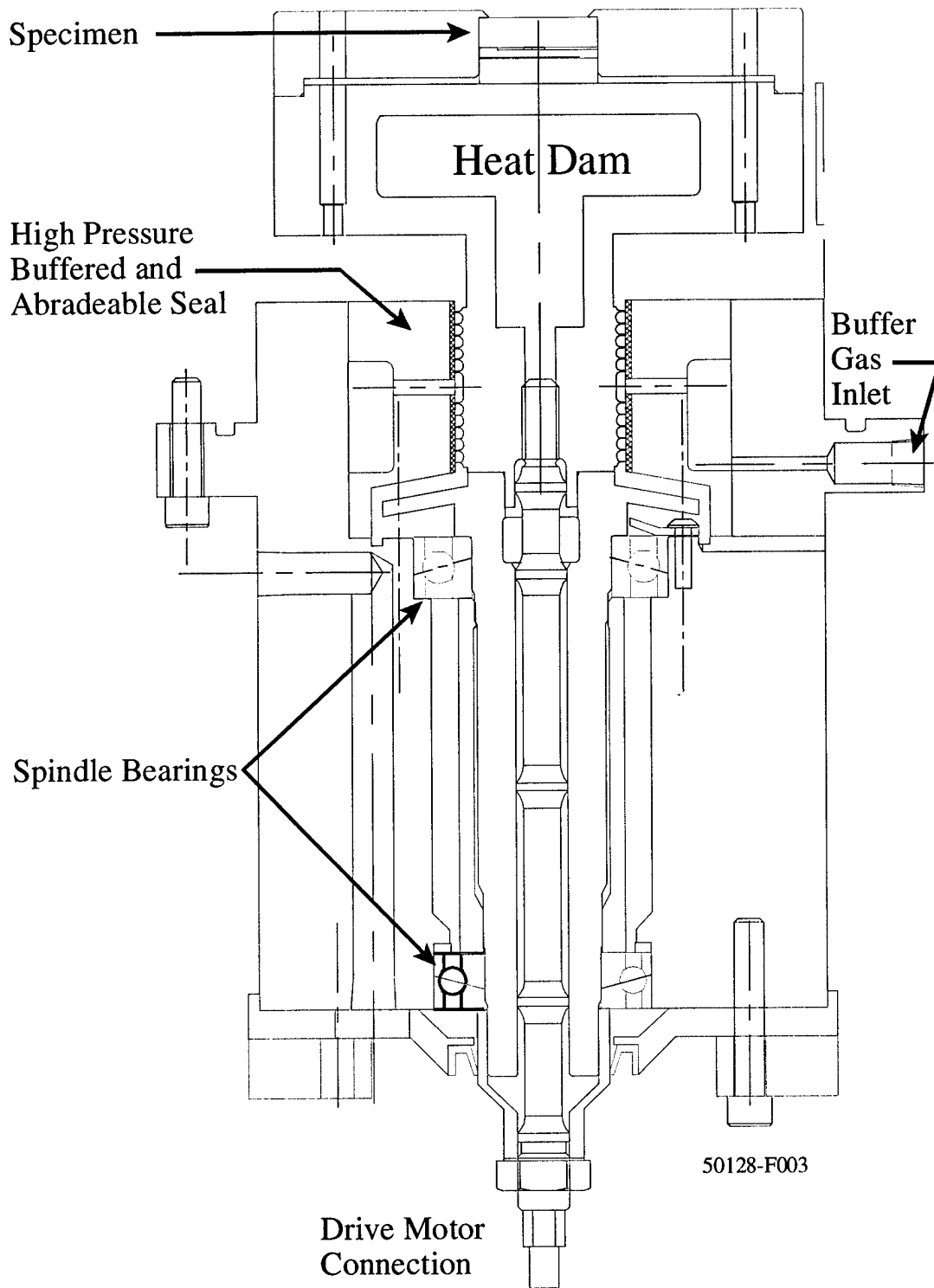

Figure 9. Cross section of drive spindle showing high pressure abradable buffer seal

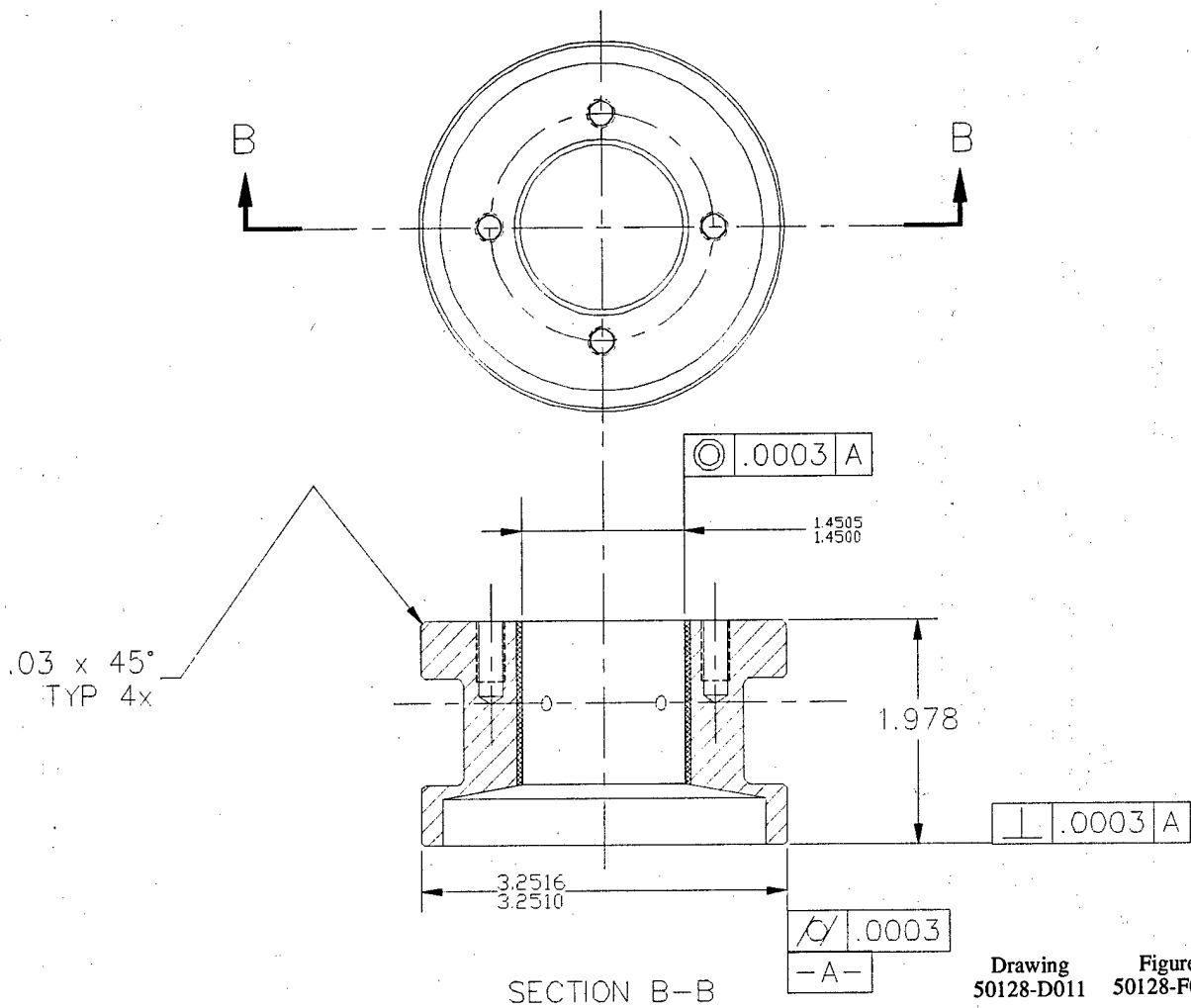

Figure 10. High pressure abradable seal design.

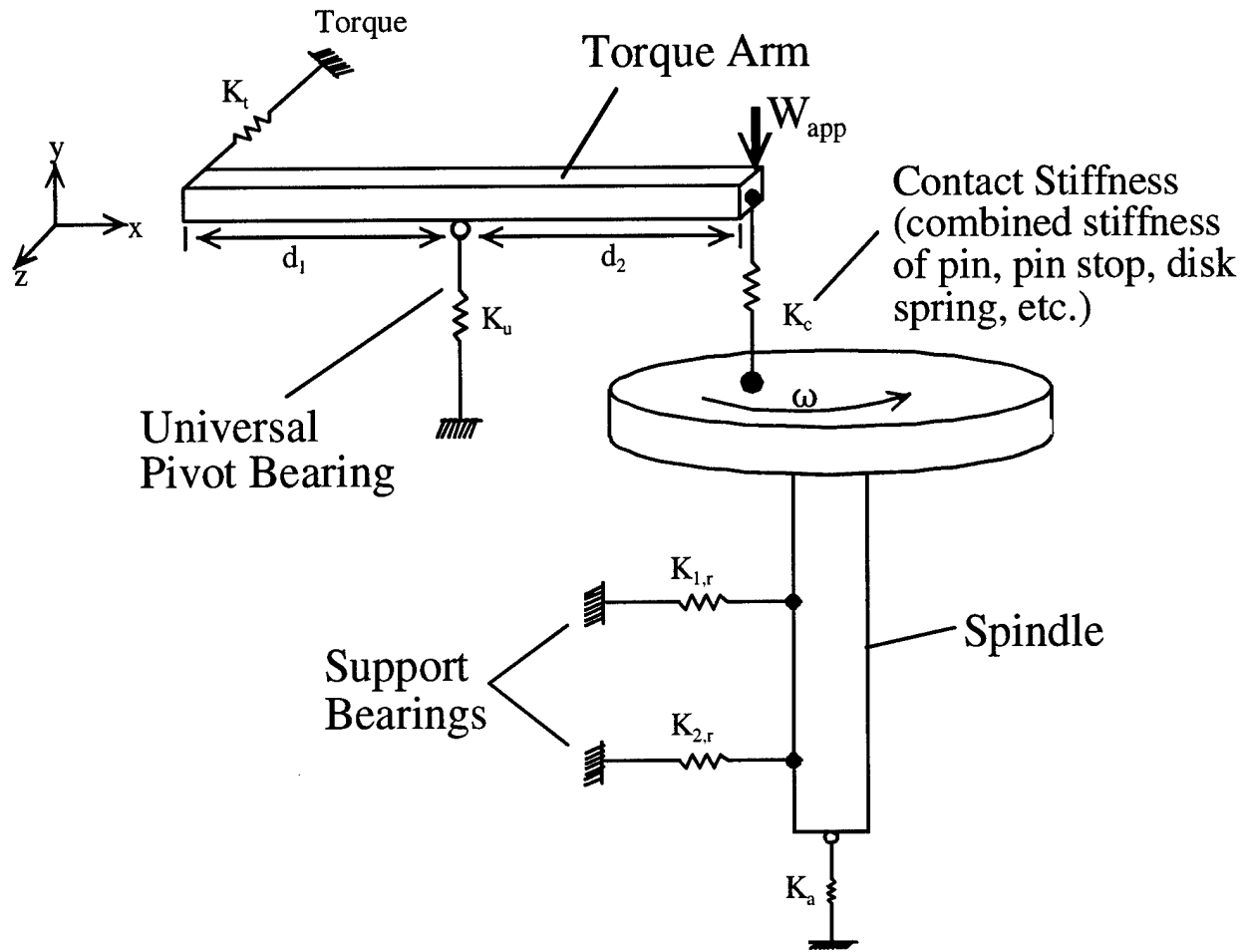

Figure 11. Pin on disc dynamic model

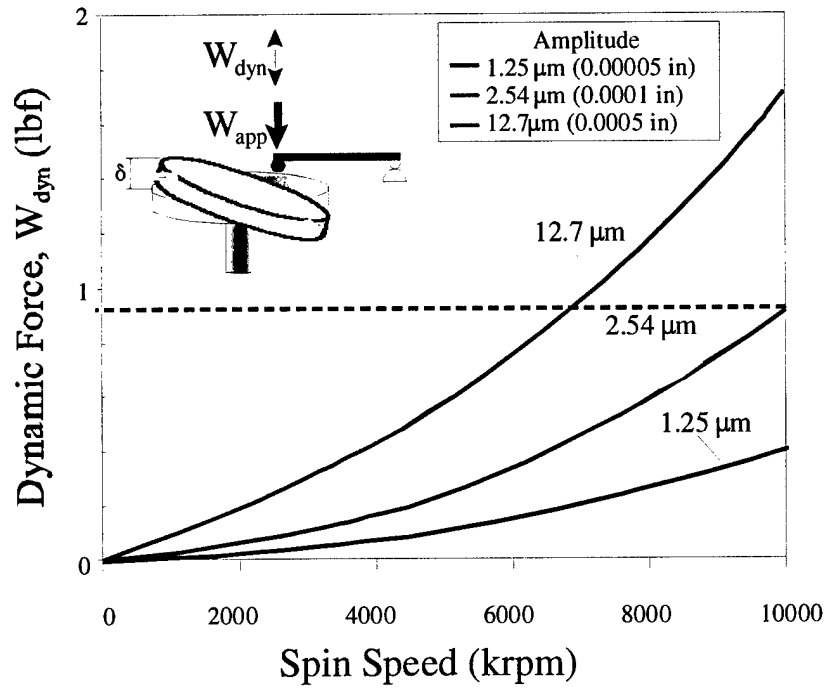

Figure 12. Dynamic force magnitude due to disc misalignment.

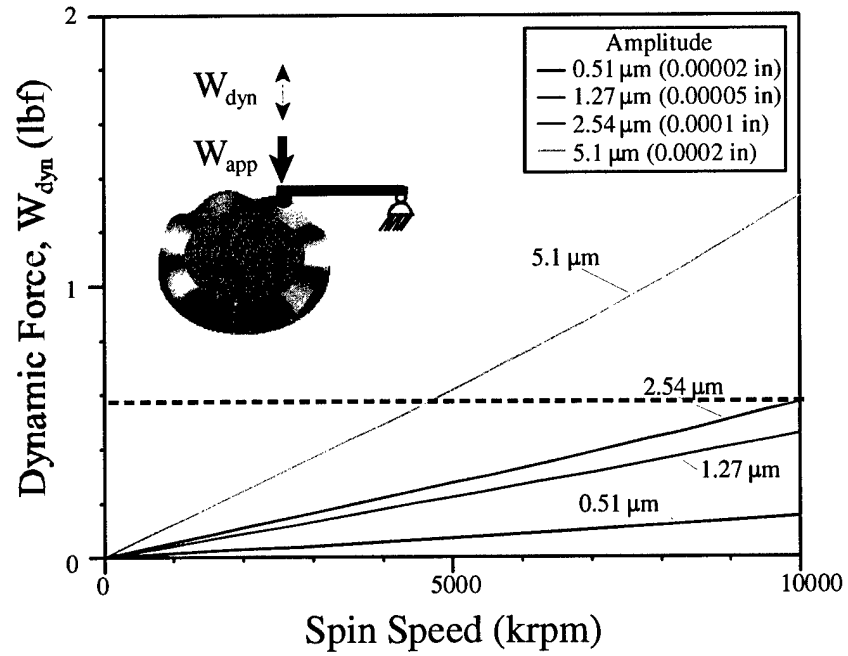

Figure 13. Dynamic force magnitude due to surface waviness.

Tribometer Fabrication

All efforts in this task are complete, all machined parts have been fabricated and assembled and the baseline testing has shown reliable operation at speeds to 10,000 rpm. The superheated steam generator was integrated into the tribometer and tested for a duration of approximately 30 minutes. The design of the tribometer is shown in Figure 8. The tribometer may be set up to operate at ambient temperature, elevated temperature or with superheated steam. Figure 14 shows the tribometer set up for high temperature testing, while Figure 15 shows the tribometer readied for superheated steam testing. Figure 16 shows the pressure dome used to seal the test specimens in the high-pressure steam.

The precision provides for very low specimen runout, less than .0001 inches total indicated reading per earlier analysis requirements, and the specimen holder allows for rapid specimen changes and repeatable registration of the specimen. The spindle is driven at speeds up to 10,000 rpm by the servomotor shown in Figure 17 and Figure 18.

The high temperature, harsh environment strain gage was applied to the torque arm and was calibrated to provide maximum sensitivity while remaining in its linear range, up to the maximum applied normal load of 400N. The pressure vessel dome was tested to increased pressures along with the buffered, abra-deable seal; however, budgetary constraints precluded operation at full, design pressure.

A sophisticated data acquisition and control system was added to oversee the motor servo controller and to collect low frequency, quasi-steady-state signals, such as motor speed and temperature. These signals needed to be accurately sampled a few times a second, displayed for monitoring purposes and saved for later data analysis. The high frequency data from the strain gage on the torque arm was sampled and stored at a rate sufficient to allow both the appropriate frequency content and time domain waveforms to be examined. The motor controller and data acquisition hardware is shown in Figure 19 below.

A LabView program was written to control, monitor and display data during testing. The user was required to set the conditions of the test, which included spindle speed, oven temperature and duration of the test, as well as setting warning limits. The program then continually collected and displayed the data while maintaining spindle speed and sent warnings or stopped the test if readings exceed preset limits. A screen capture of the front panel of this data acquisition and control program is shown in Figure 20.

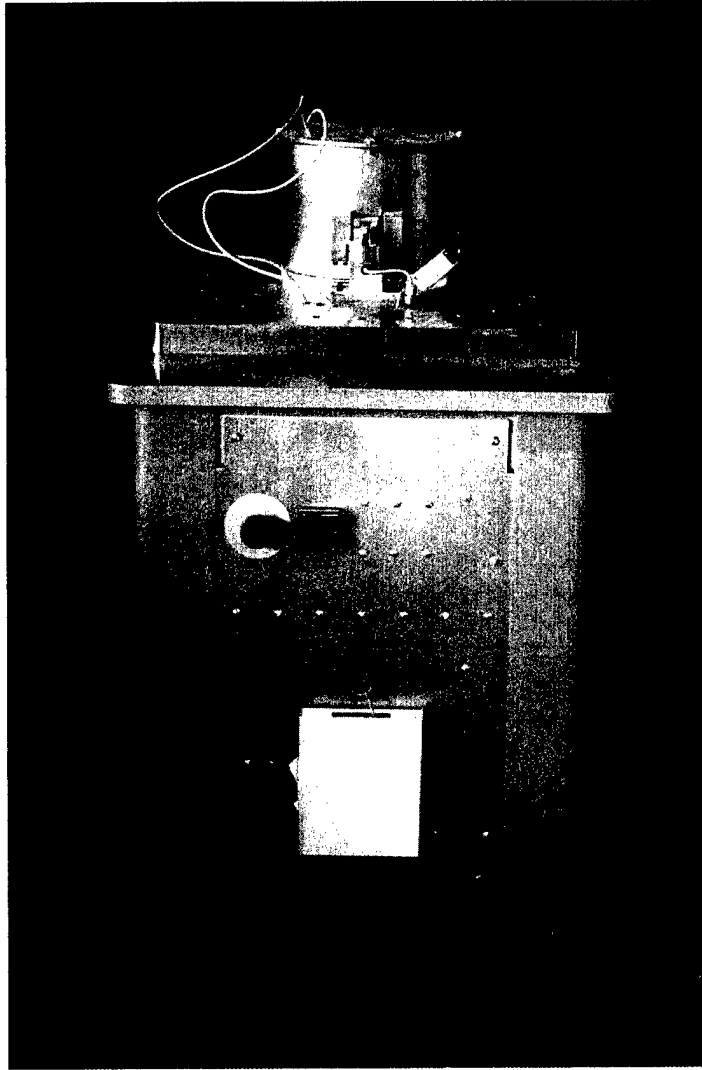

Figure 14 Tribometer set up for high temperature test

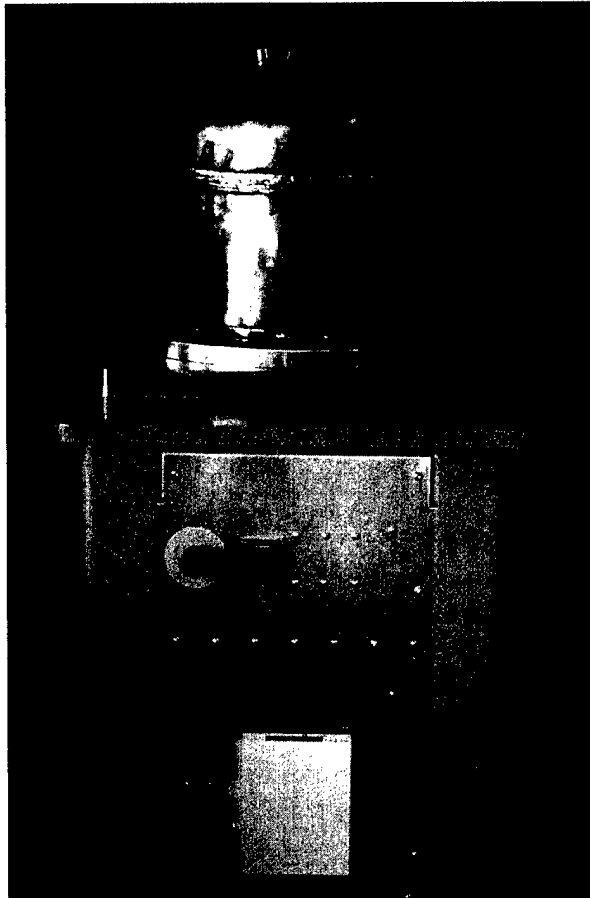

Figure 15 Tribometer set up for superheated steam

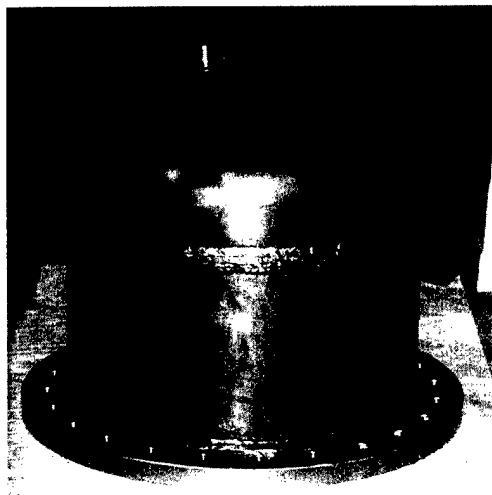

Figure 16 High Pressure Vessel

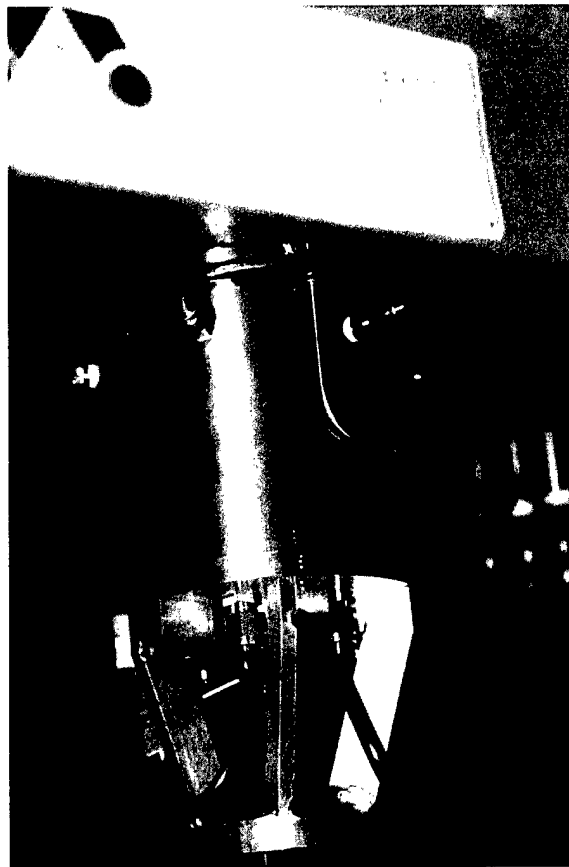

Figure 17 Spindle Housing and Motor Mount

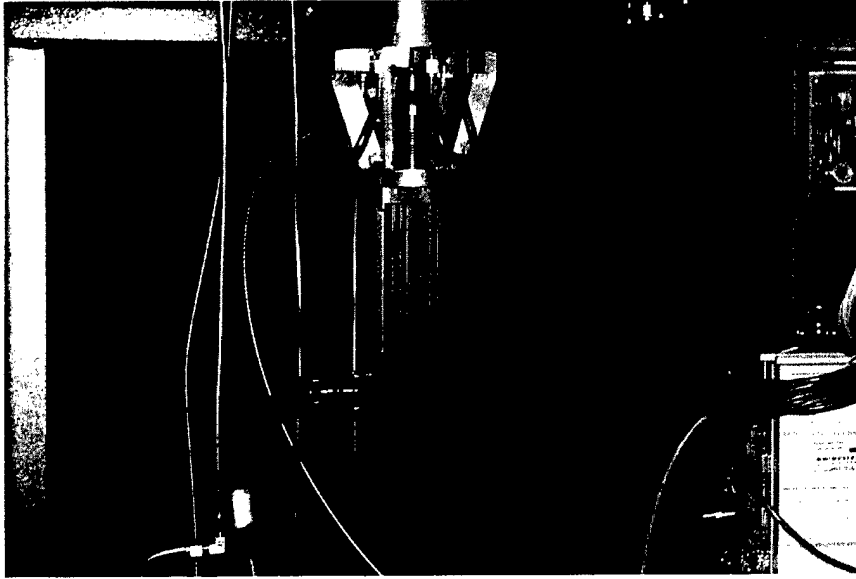

Figure 18 High Speed Servo Motor

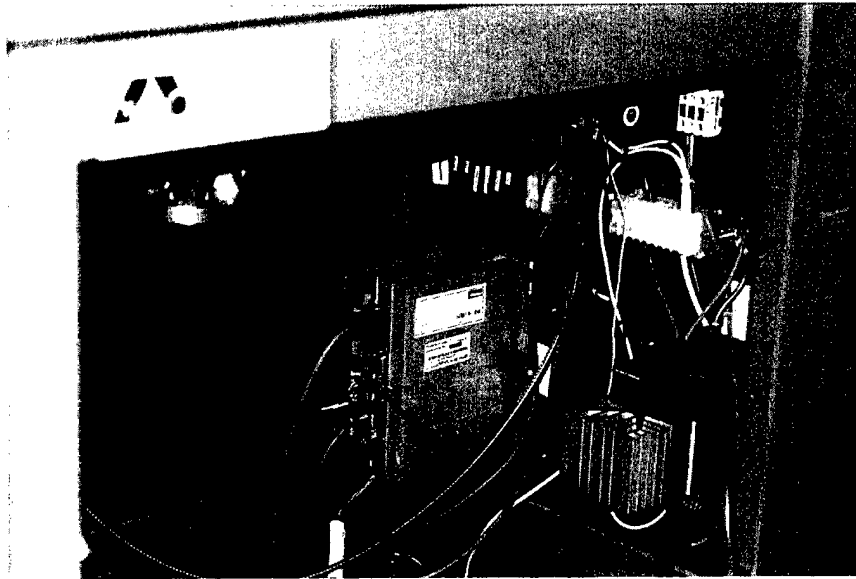

Figure 19 Motor Controller and Signal Conditioning System

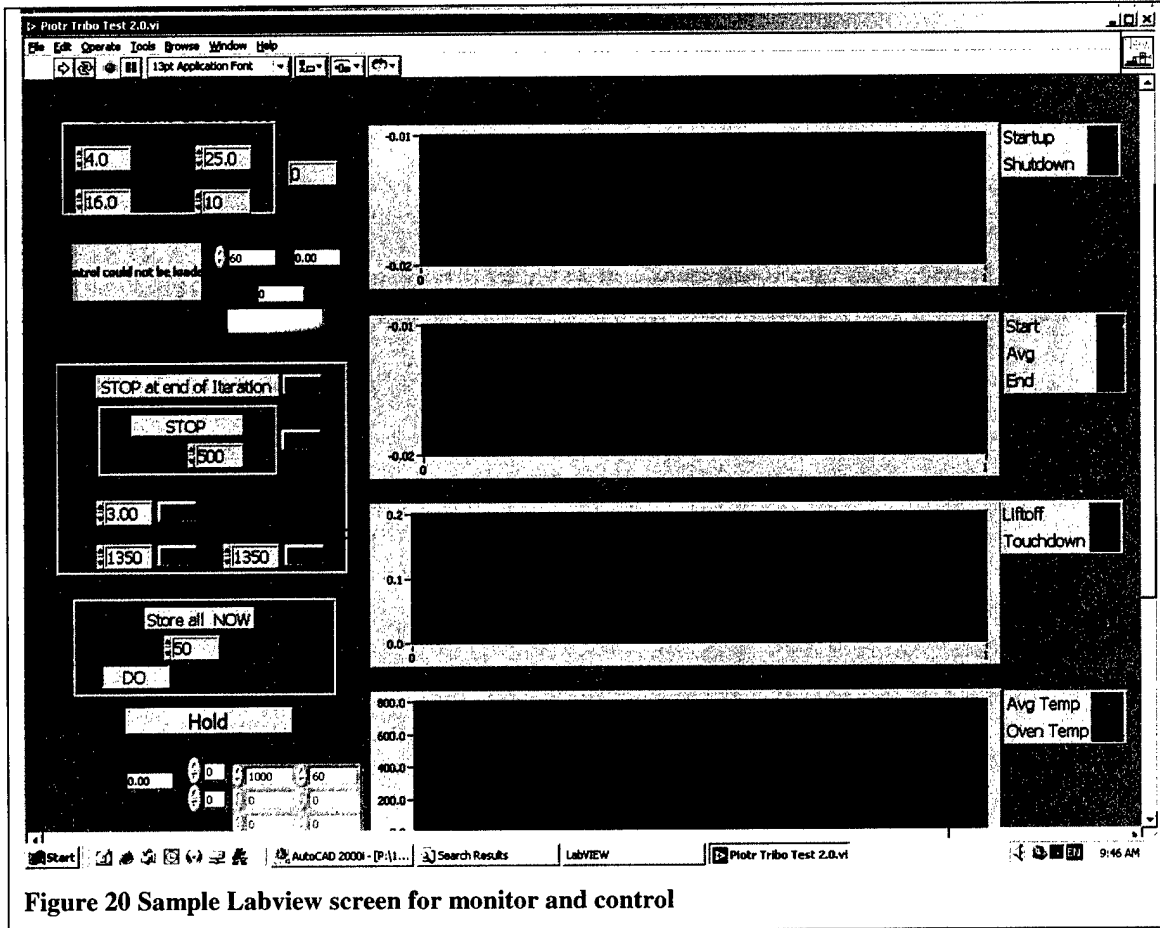

Figure 20 Sample Labview screen for monitor and control

Final Specifications

This final report completes the documentation of the High Temperature Steam Tribometer. Table 2 summarizes the features and specifications of the tribometer. To further enhance the capabilities of this tribometer, it was transferred to DARPA contract #DAAH01-02-C-R168. The transfer has been completed and future efforts will be directed toward modification of existing components and the addition of complex motion components.

Table 2. High Temperature Steam Tribometer Specifications and Features

Test Configuration	Pin on Disk
Temperature Range	25 to 800° C
Disk Speed	100 to 10,000 Rpm
Drive	Direct coupled Servo motor
Environment	High Pressure Steam
Cooling System	Water Cooling Jacket
	Water Cooled Table
	Cooling Buffer Gas
Loader	Reliable Dead Weight
	Low Loss Bearings
	Precision Factory Alignment
	Single Axis Pivot
Force	Strain Gage Measured Friction Force
Normal Loads	up to 400 N (better than 5% Accuracy)
Pin Holder	¼ inch Industry Standard
	Rapid Ball Change
Specimen Holder	1.00 inch to 4.00 inch Range
	Top Surface registration
	Rapid Specimen Change
Voltage Requirements	120 VAC
Data Output	Speed
	Friction Force
	Environment Temperature
	Friction Coefficient
Data Acquisition	National Instruments Interface Hardware
Major Components	Precision Spindle
	10,000 Variable Speed Motor
	Contaminant Free Oven
	Oven PID Controller
	Water Cooled Spindle
	Water Cooled Table
	Cooling Buffer Gas
	High Pressure Abradeable Seal
	High Pressure Containment Vessel
	Precision Specimen Holder
	Superheated Steam Generator