

**FINAL REPORT
MAY 2004**

REPORT NO. 04-01

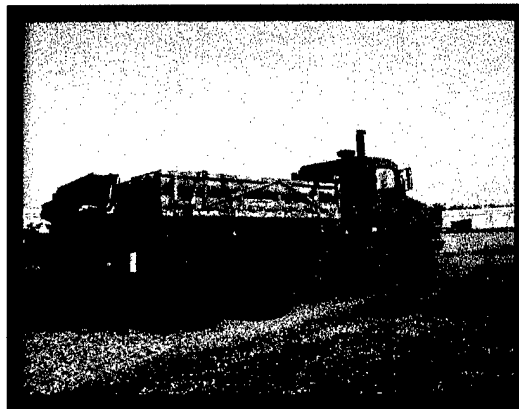
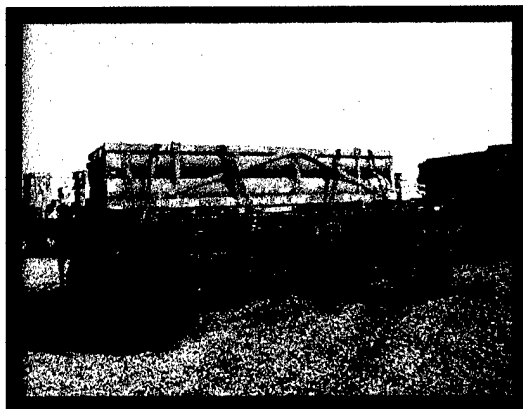

**TRANSPORTABILITY TESTING OF THE MARINE CORPS
HIGH MOBILITY ARTILLERY ROCKET SYSTEM (HIMARS)
RESUPPLY VEHICLE (RSV) AND RESUPPLY TRAILER (RST),
TP-94-01,
"TRANSPORTABILITY TESTING PROCEDURES"**

Prepared for:

Distribution Unlimited:

U.S. Army Defense Ammunition Center
ATTN: SJMAC-DET
1 C Tree Road
McAlester, OK 74501



**VALIDATION ENGINEERING DIVISION
MCALESTER, OKLAHOMA 74501-9053**

BEST AVAILABLE COPY

20040713 070

AVAILABILITY NOTICE

A copy of this report will be furnished each attendee on automatic distribution. Additional copies or authority for reprinting may be obtained by written request from:

Director
U.S. Army Defense Ammunition Center
ATTN: SJMAC-DEV
1 C Tree Road, Bldg. 35
McAlester, OK 74501-9053

DISTRIBUTION INSTRUCTIONS

Destroy this report when no longer needed. Do not return.

Citation of trade names in this report does not constitute an official endorsement.

The information contained herein will not be used for advertising purposes.

BEST AVAILABLE COPY

REPORT NO. 04-01

MAY 2004

**TRANSPORTABILITY TESTING MARINE CORPS HIGH MOBILITY
ARTILLERY ROCKET SYSTEM (HIMARS) RESUPPLY VEHICLE (RSV)
AND RESUPPLY TRAILER (RST)
TP-94-01, REV. 1, JULY 2002 "TRANSPORTABILITY TESTING
PROCEDURES"**

ABSTRACT

The U.S. Army Defense Ammunition Center (DAC), Validation Engineering Division (SJMAG-DEV), was tasked by the Marine Corps High Mobility Artillery Rocket System (HIMARS) Liaison Officer to the Program Executive Officer (PEO) Precision Fire Rocket Missile System (PFRMS) to conduct transportability testing on the Marine Corps HIMARS Resupply System (RSS). The RSS consists of the HIMARS Resupply Vehicle (RSV) and the HIMARS Resupply Trailer (RST). The testing was conducted in accordance with TP-94-01, Revision 1, July 2002 "Transportability Testing Procedures."

The objective of the testing was to evaluate the Marine Corps HIMARS RSV and RST, when transportability tested in accordance with TP-94-01, Revision 1, July 2002.

The Marine Corps HIMARS RSV and RST, as tested, are satisfactory for the transport of ammunition.

Prepared by:

Reviewed by:

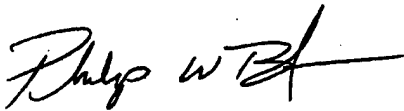

PHILIP W. BARICKMAN
Lead Validation Engineer

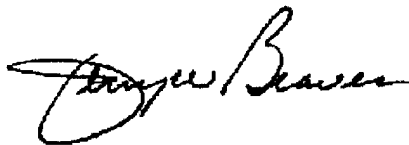

JERRY W. BEAVER
Chief, Validation Engineering Division

U.S. ARMY DEFENSE AMMUNITION CENTER

**VALIDATION ENGINEERING DIVISION
MCALESTER, OK 74501-9053**

REPORT NO. 04-01

Transportability Testing of the Marine Corps High Mobility Artillery Rocket System (HIMARS) Resupply Vehicle (RSV) and Resupply Trailer (RST), TP-94-01, Revision 1, July 2002 "Transportability Testing Procedures"

TABLE OF CONTENTS

PART	PAGE NO.
1. INTRODUCTION	1-1
A. BACKGROUND	1-1
B. AUTHORITY	1-1
C. OBJECTIVE	1-1
D. CONCLUSION	1-1
2. ATTENDEES	2-1
3. TEST EQUIPMENT	3-1
4. TEST PROCEDURES	4-1
A. RAIL TEST	4-1
B. ON/OFF ROAD TESTS	4-3
1. HAZARD COURSE	4-3
2. ROAD TRIP	4-4
3. PANIC STOPS	4-4
4. WASHBOARD COURSE	4-4
C. OCEAN GOING VESSEL	4-5
5. TEST RESULTS	5-1
5.1 TESTING DATE -13 APRIL 2004	5-1
A. RAIL TEST	5-1
B. ON/OFF ROAD TESTS	5-3
1. HAZARD COURSE	5-3
2. ROAD TRIP	5-4
3. PANIC STOPS	5-4
4. HAZARD COURSE	5-5
5. WASHBOARD COURSE	5-5
5.2 TESTING DATE -14 APRIL 2004	5-1
A. ON/OFF ROAD TESTS	5-6
1. HAZARD COURSE	5-6

2. ROAD TRIP	5-7
3. PANIC STOPS	5-7
4. HAZARD COURSE	5-8
5. WASHBOARD COURSE	5-8
B. CONCLUSION	5-8
5.3 TESTING DATE –15 APRIL 2004.....	5-9
A. ON/OFF ROAD TESTS	5-9
1. HAZARD COURSE	5-9
2. ROAD TRIP	5-10
3. PANIC STOPS	5-10
4. HAZARD COURSE	5-11
B. CONCLUSION	5-11
5.4 TESTING DATE –21 APRIL 2004.....	5-12
A. RAIL TEST	5-12
B. ON/OFF ROAD TESTS	5-16
1. HAZARD COURSE	5-16
2. ROAD TRIP	5-16
3. PANIC STOPS	5-17
4. HAZARD COURSE	5-17
5. WASHBOARD COURSE	5-17
C. CONCLUSION	5-18
6. DRAWINGS	6-1

PART 1 – INTRODUCTION

A. BACKGROUND. The U.S. Army Defense Ammunition Center (DAC), Validation Engineering Division (SJMAC-DEV), was tasked by the Marine Corps High Mobility Artillery Rockets Systems (HIMARS) Liaison Officer to the Program Executive Officer (PEO) Precision Fire Rocket Missile System (PFRMS) to conduct transportability testing on the Marine Corps HIMARS Resupply System (RSS). The RSS consists of the HIMARS Resupply Vehicle (RSV) and the HIMARS Resupply Trailer (RST). The testing was conducted in accordance with TP-94-01, Revision 1, July 2002 “Transportability Testing Procedures.”

B. AUTHORITY. This test was conducted IAW mission responsibilities delegated by the U.S. Army Joint Munitions Command (JMC), Rock Island, IL. Reference is made to the following:

1. AR 740-1, 15 June 2001, Storage and Supply Activity Operation.
2. OSC-R, 10-23, Mission and Major Functions of U.S. Army Defense Ammunition Center (DAC) 21 Nov 2000.

C. OBJECTIVE. The objective of the testing was to evaluate the Marine Corps HIMARS RSV and RST, when transportability tested in accordance with TP-94-01, Revision 1, July 2002.

D. CONCLUSION. The Marine Corps HIMARS RSV and RST, as tested, are satisfactory for the transport of ammunition.

PART 2 - ATTENDEES

ATTENDEE

MAILING ADDRESS

Philip Barickman
DSN 956-8992
(918) 420-8992

Director
U.S. Army Defense Ammunition Center
ATTN: SJMAC-DEV
1 C Tree Road, Bldg. 35
McAlester, OK 74501-9053

Timothy Presley
Senior Test Engineer
(256)882-0836 ext. 253

AI Signal Research, Inc.
3411 Triana Blvd, SW
Huntsville, AL 35805

Shawn DeHart
Reliability Engineer
(256)882-0836 ext. 223

AI Signal Research, Inc.
3411 Triana Blvd, SW
Huntsville, AL 35805

PART 3 - TEST EQUIPMENT

1. HIMARS Resupply Vehicle

Model No: MK37

Serial No: 078010

Empty Weight: 33,960 pounds (as tested)

Maximum Cargo: 22,000 pounds

GVWR: 62,200 pounds

Vehicle ID No: 10TDMWE363S078010

Manufacturer: Oshkosh Truck Corporation

Date of Manufacture: 04/03

Height: 141.6 inches

Width: 98 inches

Length: 359.7 inches

2. HIMARS Resupply Trailer

Model No: MK38

Serial No: 004

Empty Weight: 9,320 pounds (as tested)

GVWR: 22,000 pounds

Manufacturer: Oshkosh Truck Corporation

Date of Manufacture: 01/03

Height: 88.1 inches

Width: 98 inches

Length: 315 inches (including drawbar)

Length: 227 inches (drawbar up)

PART 4 - TEST PROCEDURES

The test procedures outlined in this section were extracted from TP-94-01, Revision 1 "Transportability Testing Procedures," dated July 2002, for validating tactical vehicles and outloading procedures used for shipping munitions by tactical or commercial truck, railcar, and ocean-going vessel.

Inert (non-explosive) items will be used to build the load. The test loads will be prepared using the blocking and bracing procedures proposed for use with munitions (**see Part 6 for procedures**). The weight and physical characteristics (weights, physical dimensions, center of gravity, etc.) of the test loads will be similar to live (explosive) ammunition.

A. RAIL TEST. RAIL IMPACT TEST METHOD. The test load or vehicle will be secured to a flatcar. The equipment needed to perform the test will include the specimen (hammer) car, four empty railroad cars connected together to serve as the anvil, and a railroad locomotive. The anvil cars will be positioned on a level section of track with air and hand brakes set and with draft gears compressed. The locomotive unit will push the specimen car toward the anvil at a predetermined speed, then disconnect from the specimen car approximately 50 yards away from the anvil cars allowing the specimen car to roll freely along the track until it strikes the anvil. This will constitute an impact. Impacting will be accomplished at speeds of 4, 6, and 8.1 mph in one direction and at a speed of 8.1 mph in the reverse direction. The speeds will have a tolerance of plus .5 mph and minus zero mph. The impact speeds will be determined by using an electronic counter to measure the time for the specimen car to traverse an 11-foot distance immediately prior to contact with the anvil cars (see Figure 1).

ASSOCIATION OF AMERICAN RAILROADS (AAR)

STANDARD TEST PLAN

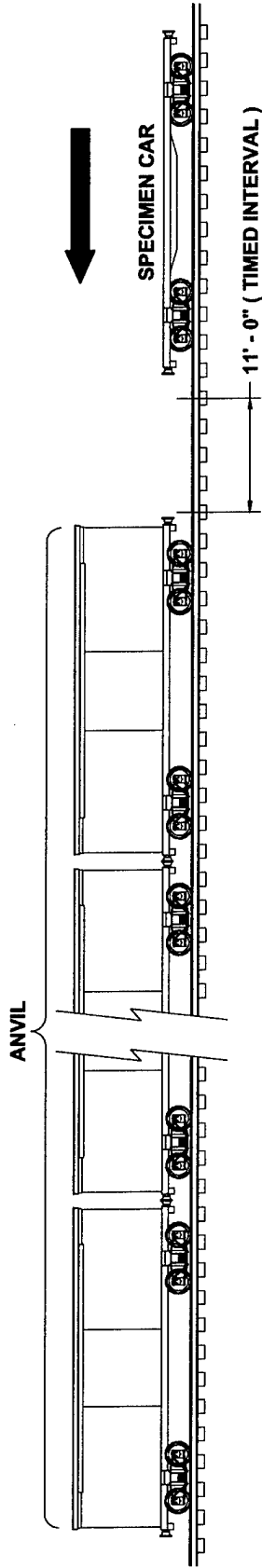

SPECIMEN CAR IS RELEASED BY SWITCH ENGINE TO ATTAIN:

- IMPACT NO. 1 @ 4 MPH**
- IMPACT NO. 2 @ 6 MPH**
- IMPACT NO. 3 @ 8.1 MPH**

THEN THE CAR IS REVERSED AND RELEASED BY SWITCH ENGINE TO ATTAIN:

- IMPACT NO. 4 @ 8.1 MPH**

4 BUFFER CARS (ANVIL) WITH DRAFT GEAR COMPRESSED AND AIR BRAKES IN A SET POSITION

ANVIL CAR TOTAL WT. 250,000 LBS (APPROX)

Figure 1. Rail Impact Sketch

B. ON/OFF ROAD TESTS.

1. **HAZARD COURSE.** The test load or vehicle will be transported over the 200-foot-long segment of concrete-paved road consisting of two series of railroad ties projecting 6 inches above the level of the road surface. The hazard course will be traversed two times (see Figure 2).

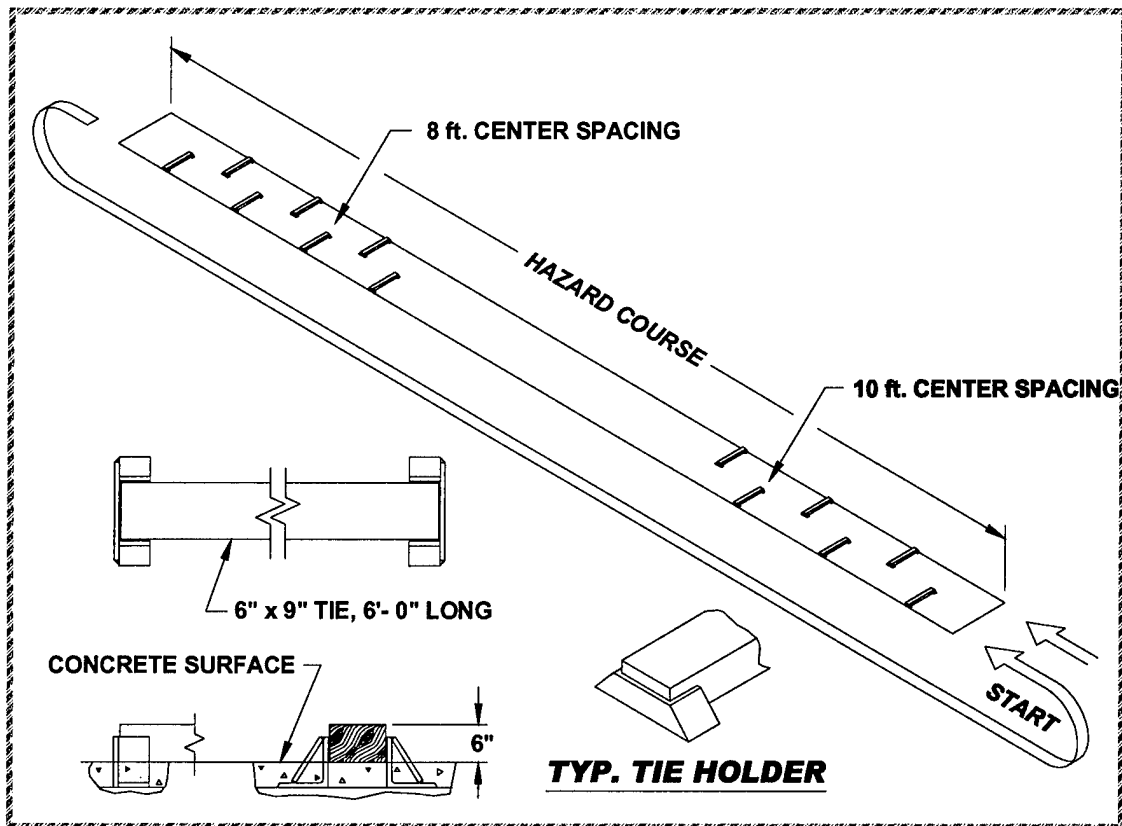

Figure 2. Hazard Course Sketch

- a. The first series of 6 ties are spaced on 10-foot centers and alternately positioned on opposite sides of the road centerline for a distance of 50 feet.
- b. Following the first series of ties, a paved roadway of 75 feet separates the first and second series of railroad ties.
- c. The second series of 7 ties are spaced on 8-foot centers and alternately positioned on opposite sides of the road centerline for a distance of 50 feet.

d. The test load is driven across the hazard course at speeds that will produce the most violent vertical and side-to-side rolling reaction obtainable in traversing the hazard course (approximately 5 mph).

2. **ROAD TRIP.** The test load or vehicle will be transported for a distance of 30 miles over a combination of roads surfaced with gravel, concrete, and asphalt. The test route will include curves, corners, railroad crossings and stops and starts. The test load or vehicle will travel at the maximum speed for the particular road being traversed, except as limited by legal restrictions.

3. **PANIC STOPS.** During the road trip, the test load or vehicle will be subjected to three (3) full airbrake stops while traveling in the forward direction and one in the reverse direction while traveling down a 7 percent grade. The first three stops are at 5, 10, and 15 mph while the stop in the reverse direction is approximately 5 mph. This testing will not be required if the Rail Impact Test is performed.

4. **WASHBOARD COURSE.** The test load or vehicle will be driven over the washboard course at a speed that produces the most violent response in the vertical direction.

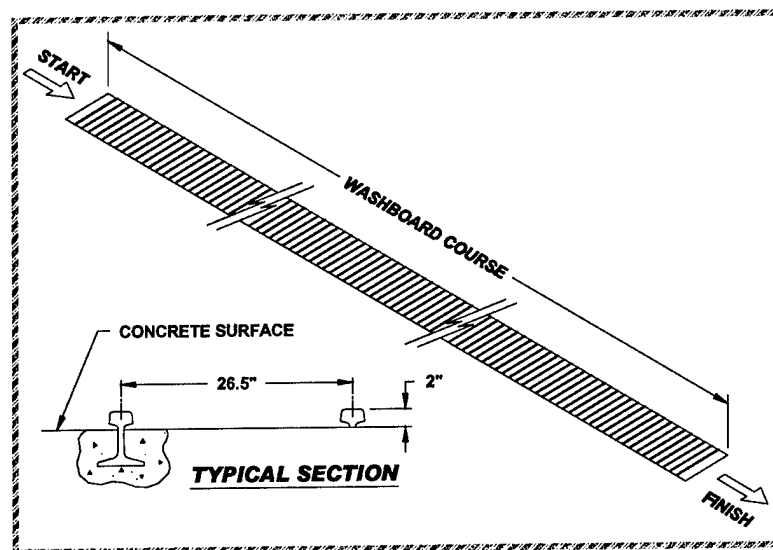

Figure 3. Washboard Course Sketch

C. OCEAN-GOING VESSEL TEST. SHIPBOARD TRANSPORTATION

SIMULATOR (STS) TEST METHOD. The test load will be secured inside an ISO container and will be positioned onto the STS and securely locked in place using the cam locks at each corner. Oscillation of the STS will be started and rotate to an angle of 30 degrees plus or minus 2 degrees, either side of center and at a frequency of 2 cycles-per-minute (30 seconds, plus or minus 2 seconds total roll period). This frequency will be observed for apparent defects that could cause a safety hazard. The frequency of oscillation will then be increased to 4 cycles-per-minute (15 seconds, plus or minus 1 second per roll period) and the apparatus operated a period of two (2) hours. An inspection of the load will then be conducted. If the inspection does not indicate an impending failure, the frequency of oscillation will be further increased to 5 cycles-per-minute (12 seconds, plus or minus 1 second-cycle time), and the apparatus operated for four (4) hours. The operation does not necessarily have to be continuous, however, no change or adjustments to the load or load restraints will be permitted at any time during the test. After once being set in place, the test load (specimen) will not be removed from the apparatus until the test has been completed or is terminated.

PART 5 - TEST RESULTS

5.1

Payload: 2 Multiple Launch Rocket System (MLRS) Pods on the RSV and RST.

Testing Date: 13 April 2004

Gross Weight: 64,340 pounds

Payload Weight: 21,060 pounds

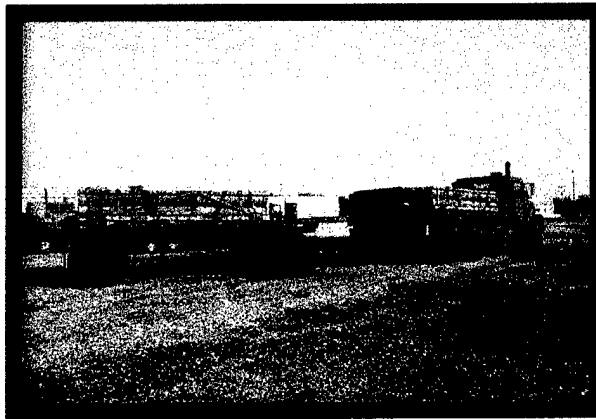
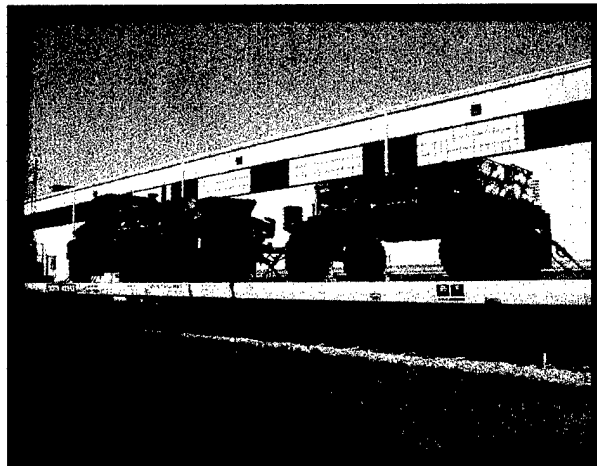

Photo 1. RSV and RST with 2 Pods Each

A. RAIL TEST.



**Photo 2. Rail Impact Testing of RSV and RST with 2 Pods
(Prior to Testing)**

Description	Weight
Flatcar Number: DODX 42353	85,000 lbs.
RSV and RST with 2 Pods Each	64,340 lbs.
Total Specimen Wt.	149,340 lbs.
Buffer Car (four cars)	257,900 lbs.

Figure 4.

Remarks: Figure 5 lists the test components and weights of the items used during the Rail Impact Tests.

Impact Number	Avg. Velocity (mph)
1	3.8
2	4.4
3	6.7
4	8.8
5	8.1

Figure 5.

Remarks:

1. Figure 5 lists the average speeds of the specimen car immediately prior to impact with the anvil. Impact #5 is the reverse impact.
2. Impact #1 was determined to be a "no test" due to the insufficient velocity at impact. The test was repeated.
3. Following Impact #1 the pod on the trailer driver's side moved in the direction of impact 0.5 inches (toward the rear of the trailer).
4. Following Impact #2 the pod on the trailer driver's side moved in the direction of impact an additional 0.25 inches (toward the rear of the trailer).
5. Following Impact #3 the pod on the truck driver's side moved in the direction of impact 0.375 inches (toward the rear of the truck).
6. Following Impact #4 the pod on the trailer driver's side moved in the direction of impact 0.25 inches (toward the rear of the trailer). The pod on the truck

passenger side moved in the direction of impact 0.25 inches (toward the rear of the truck).

7. Following Impact #5 the pods on the truck moved 1.25-1.375 inches in the direction of impact (toward the front of the truck). The strap on the driver's side rear was loose but adequately restrained the load.

B. ON/OFF ROAD TESTS.

1. HAZARD COURSE.



Photo 3. Hazard Course Testing of the RSV and RST with 2 Pods

Pass No.	Elapsed Time	Avg. Velocity (mph)
1	25 Seconds	6.2
2	25 Seconds	6.2

Figure 6.

Remarks:

1. Figure 6 lists the average speeds of the test load through the Hazard Course.
2. Inspections following each pass revealed no visible movement of the payload, damage to the truck, trailer, tie-downs or straps.

2. ROAD TRIP:

Remarks:

1. The Road Trip was conducted between the Road Hazard Course Passes #2 and #3.
2. Inspection following the Road Trip revealed no visible movement of the payload, damage to the truck, trailer, tie-downs or straps.

3. PANIC STOPS: Testing was not required since the load was rail impact tested.

4. HAZARD COURSE:

Pass No.	Elapsed Time	Avg. Velocity (mph)
3	22 Seconds	7.1
4	26 Seconds	6.0

Figure 7.

Remarks:

1. Figure 7 lists the average speeds of the test load through the Hazard Course.
2. Inspection following each pass revealed no visible movement of the payload, damage to the truck, trailer, tie-downs or straps.

5. WASHBOARD COURSE:

Remark:

Inspection following the completion of the washboard course revealed no visible movement of the payload, damage to the truck, trailer, tie-downs or straps.

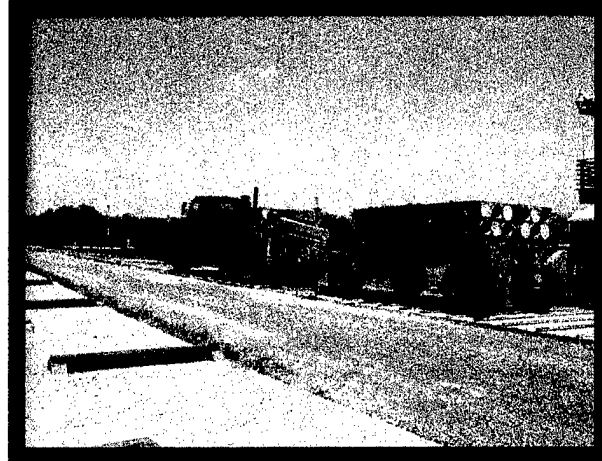

Photo 4. Washboard Course Testing of the RSV and RST with 2 Pods

C. CONCLUSION: The RSV and RST, when tested with 2 pods each, performed adequately during testing. Therefore, the RST and RSV, as tested, are adequate for transport of ammunition.

5.2

Payload: Half Payload: 1 Multiple Launch Rocket System (MLRS) Pod on the RSV and RST.

Testing Date: 14 April 2004

Gross Weight: 54,060 pounds

Payload Weight: 10,780 pounds

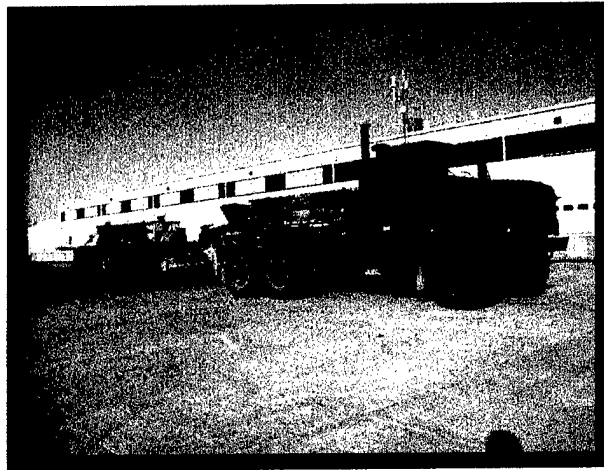

Photo 5. RSV and RST with 1 Pod Each

A. ON/OFF ROAD TESTS.

1. HAZARD COURSE.



Photo 6. Hazard Course Testing of the RSV and RST with 1 Pod

Pass No.	Elapsed Time	Avg. Velocity (mph)
1	23 Seconds	6.8
2	28 Seconds	5.6

Figure 8.

Remarks:

1. Figure 8 lists the average speeds of the test load through the Hazard Course.
2. Inspection following Pass #1 revealed that the pod on the trailer passenger side moved 0.125 inches toward the center and 0.125 inches toward the rear of the trailer.
3. Inspections following each pass revealed no visible movement of the payload, damage to the truck, trailer, tie-downs, or straps.

2. ROAD TRIP:

Remarks:

1. The Road Trip was conducted between the Road Hazard Course Passes #2 and #3.
2. Inspection following completion of the Road Trip revealed that the pod on the truck passenger side moved 0.125 inches toward the driver's side.
3. Inspection revealed no visible movement of the payload, damage to the truck, trailer, tie-downs or straps.

3. PANIC STOPS:

Remarks:

1. The Panic Stops were conducted during the Road Trip.
2. Inspections following each stop revealed no visible movement of the payload, damage to the truck, trailer, tie-downs or straps.

4. HAZARD COURSE:

Pass No.	Elapsed Time	Avg. Velocity (mph)
3	29 Seconds	5.4
4	29 Seconds	5.4

Figure 9.

Remarks:

1. Figure 9 lists the average speeds of the test load through the Hazard Course.
2. Inspection following Pass #3 revealed that the pod on the trailer passenger side moved and additional 0.25 inches toward the rear of the trailer.
3. Inspections following each pass revealed no visible movement of the payload, damage to the truck, trailer, tie-downs or straps.

5. WASHBOARD COURSE:

Remark: Inspection following the completion of the Washboard Course revealed no visible movement of the payload, damage to the truck, trailer, tie-downs or straps.

B. CONCLUSION: The RSV and RST, when tested with 1 pod each, performed adequately during testing. Therefore, the RST and RSV, as tested, are adequate for transport of ammunition.

5.3

Payload: Highway Payload: 4 Multiple Launch Rocket System (MLRS) Pods on the RSV.

Testing Date: 15 April 2004

Gross Weight: 54,780 pounds

Payload Weight: 20,820 pounds

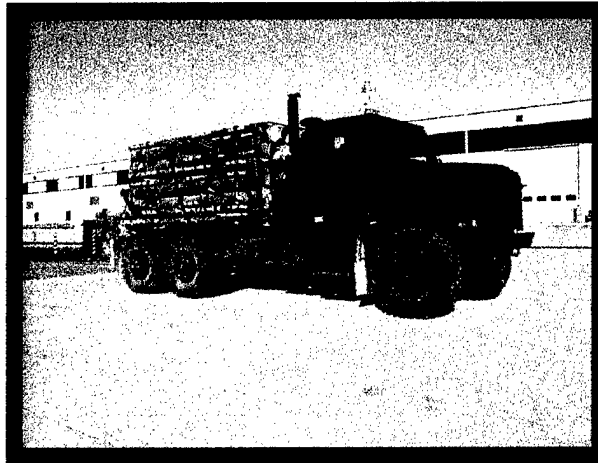

Photo 7. RSV with 4 Pods

A. ON ROAD TESTS.

1. HAZARD COURSE.



Photo 8. Hazard Course Testing of the RSV with 4 Pods

Pass No.	Elapsed Time	Avg. Velocity (mph)
1	23 Seconds	5.9
2	21 Seconds	6.4

Figure 10.

Remarks:

1. Figure 10 lists the average speeds of the test load through the Hazard Course.
2. Inspections following each pass revealed no visible movement of the payload, damage to the truck, trailer, tie-downs, or straps.

2. ROAD TRIP:

Remarks:

1. The Road Trip was conducted between the Road Hazard Course Passes #2 and #3.
2. Inspection following the completion of the road trip revealed no visible movement of the payload, damage to the truck, trailer, tie-downs or straps.

3. PANIC STOPS:

Remarks:

1. The Panic Stops were conducted during the Road Trip.
2. Inspection following the forward 5 MPH stop revealed that the pods moved 0.375 inches toward the front of the truck.
3. Inspection following the reverse 5 MPH stop revealed that the pods moved 0.25 inches toward the rear of the truck.
4. Inspections following each stop revealed no visible movement of the payload, damage to the truck, trailer, tie-downs or straps.

4. HAZARD COURSE:

Pass No.	Elapsed Time	Avg. Velocity (mph)
3	21 Seconds	6.4
4	19 Seconds	7.1

Figure 11.

Remarks:

1. Figure 11 lists the average speeds of the test load through the Hazard Course.
2. Inspection following Pass #4 revealed that the pods moved 0.125 inches toward the front of the truck.
3. Inspections following each pass revealed no visible movement of the payload, damage to the truck, trailer, tie-downs or straps.

B. CONCLUSION: The RSV, when tested with 4 pods, performed adequately during testing. Therefore, the RST and RSV, as tested, are adequate for transport of ammunition.

5.4

Payload: 155 MM Separate Loading Projectiles (SLPs) on the on the RSV and RST.

Testing Date: 21 April 2004

Gross Weight: 71,620 pounds

Payload Weight: 28,340 pounds

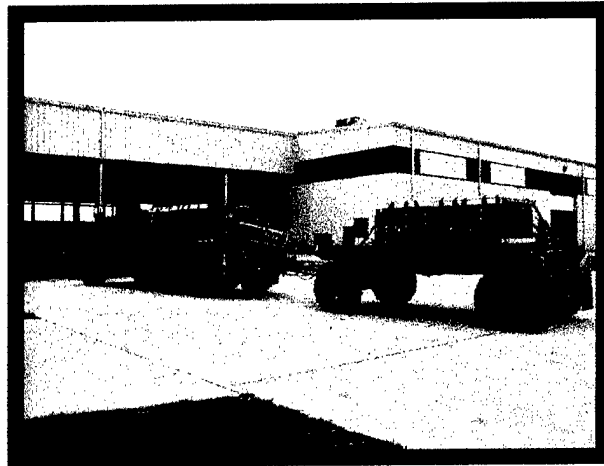

Photo 9. RSV and RST with 155MM SLPs

A. RAIL TEST.



**Photo 10. Rail Impact Testing of RSV and RST with 155 MM SLP
(Prior to Testing)**

Description	Weight
Flatcar Number: DODX 42353	85,000 lbs.
RSV and RST with 155 MM SLP	71,620 lbs.
Total Specimen Wt.	156,620 lbs.
Buffer Car (four cars)	257,900 lbs.

Figure 12.

Remarks: Figure 12 lists the test components and weights of the items used during the Rail Impact Tests.

Impact Number	Avg. Velocity (mph)
1	4.3
2	6.4
3	7.7
4	7.6
5	8.9
6	7.8
7	8.3

Figure 13.

Remarks:

- Figure 13 lists the average speeds of the specimen car immediately prior to impact with the anvil. Impact #7 is the reverse impact.
- Impacts #3,4,6 were to be a "no test" due to the insufficient velocity at impact. The test was repeated.
- Following Impact #3 the projectiles on the truck and trailer moved in the direction of impact 0.125 inches (toward the rear of the truck and the trailer). The strap on the rear of the trailer was in contact with the shoe on the trailer (See Photo 11). When installing the straps, the straps must be installed above the height of the shoes on the RSV and RST. This will prevent the strap-to-shoe contact and will prevent wear and abrasion to the strap.

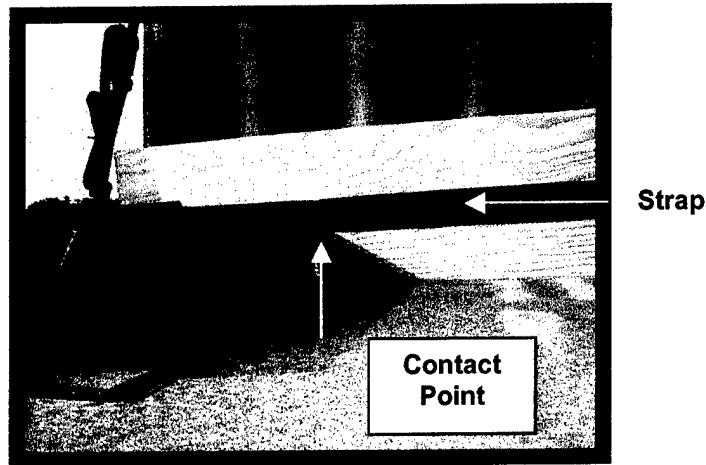

Photo 11. Strap in Contact With Trailer Shoe

4. Following Impact #4 the projectiles on the truck and trailer moved in the direction of impact an additional 0.125 inches (toward the rear of the truck and trailer). The dunnage assembly on the rear of the trailer bowed (See Photo 12). The shoes on the truck and the trailer helped restrain the payload and dunnage assembly.

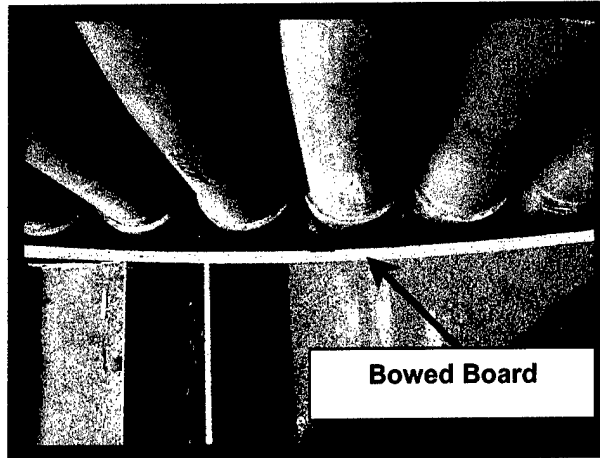

Photo 12. Bowed Dunnage Assembly

5. Following Impact #5 the projectiles on the truck moved in the direction of impact an additional 0.75 inches (toward the rear of the truck). The dunnage assembly of the rear of the truck also bowed. The shoe on the rear of the truck was cutting into the dunnage assembly (See Photo 13). The projectiles on the trailer moved in the direction of impact an additional 0.5 inches (toward the rear

of the trailer). The strap on the dunnage assembly on the front of the truck and trailer loosened, but adequately restrained the load.



Photo 13. Dunnage Assembly Damage from Contact with the Shoe

6. Following Impact #6 the projectiles on the truck moved 1-inch and on the trailer moved 0.75 inches in the direction of impact (toward the front of the truck and trailer). The cleat of the dunnage assembly on the driver's side rear of the truck disengaged. The nails on the cleat were damaged when the board was forced into position. Removing 0.5 inches from the cleat height can prevent this damage. The height of the cleats of the dunnage assembly on the trailer was reduced by 0.5 inches and no damage occurred during testing.

7. Following Impact #7 the projectiles on the truck moved in the direction of impact 1-inch (toward the front of the truck). The strap on the dunnage assembly loosened on the non-impact end of the truck, but adequately restrained the load.

B. ON/OFF ROAD TESTS.

1. HAZARD COURSE.



Photo 14. Hazard Course Testing of the RSV and RST with 155 MM SLP

Pass No.	Elapsed Time	Avg. Velocity (mph)
1	33 Seconds	4.7
2	31 Seconds	5.0

Figure14.

Remarks:

1. Figure 14 lists the average speeds of the test load through the Hazard Course.
2. Inspections following each pass revealed no visible movement of the payload, damage to the truck, trailer, tie-downs, or straps.

2. ROAD TRIP:

Remarks:

1. The Road Trip was conducted between the Road Hazard Course Passes #2 and #3.
2. Inspection following the Road Trip revealed no visible movement of the payload, damage to the truck, trailer, tie-downs or straps.

3. PANIC STOPS:

Remarks: Testing was not required since the load was rail impact tested.

4. HAZARD COURSE:

Pass No.	Elapsed Time	Avg. Velocity (mph)
3	27 Seconds	5.8
4	31 Seconds	5.0

Figure 15.

Remarks:

1. Figure 15 lists the average speeds of the test load through the Hazard Course.
2. Inspection following Pass #3 revealed that the projectiles moved 0.5-0.75 inches toward the passenger side of the trailer,
3. Inspections following each pass revealed no visible movement of the payload, damage to the truck, trailer, tie-downs or straps.

5. WASHBOARD COURSE:

Remarks: Inspection following the completion of the washboard course revealed no visible movement of the payload, damage to the truck, trailer, tie-downs or straps.



Photo 15. Washboard Course Testing of the RSV and RST with 155MM SLPs

C. CONCLUSION: The RSV and RST, when tested with 155MM Separate Loading Projectiles, performed adequately during testing. Therefore, the RST and RSV, as tested, are adequate for transport of ammunition.

PART 6 – DRAWINGS

The following drawing represents the load configuration that was subjected to the test criteria.

TEST SKETCH

LOADING AND TIEDOWN PROCEDURES FOR AMMUNITION ITEMS LOADED ON THE USMC HIMARS MTRV RESUPPLY VEHICLE AND RESUPPLY TRAILER

NOTE: THE AMMUNITION TIEDOWN PROCEDURES CONTAINED WITHIN THIS DOCUMENT ARE TYPICAL. THE DEPICTED ITEMS ARE REPRESENTATIVE OF THE VARIOUS TYPES OF AMMUNITION THAT MAY BE RESTRAINED AND TRANSPORTED ON THE USMC HIGH MOBILITY ARTILLERY ROCKET SYSTEM (HIMARS) MEDIUM TACTICAL VEHICLE REPLACEMENT (MTRV) RESUPPLY VEHICLE AND RESUPPLY TRAILER. THESE PROCEDURES WERE USED IN SUPPORT OF THE MTRV AMMUNITION CERTIFICATION TRANSPORTABILITY TEST PROGRAM.

Prepared during April 2004 by:
U.S. Army Defense Ammunition Center
ATTN: SJMAC-DET
McAlester, OK 74501
POC: Mr. Richard Garside
DSN 956-8050
Comm (918) 420-8050
Fax 956-8811
E-mail: richard.garside@dac.army.mil

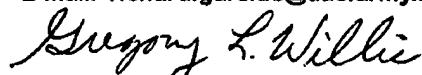

Gregory L. Willis
Chief,
Transportation Engineering Division

GENERAL NOTES

- A. WEB STRAP TIEDOWN ASSEMBLIES MUST BE SECURELY HOOKED INTO ANCHORING DEVICES ON THE TRANSPORTING VEHICLE AND FIRMLY TENSIONED. FIRMLY TENSIONED MEANS WHEN THE OPERATOR PULLS ON THE RATCHET HANDLE BY HAND, THE RATCHET WILL NOT ADVANCE ANOTHER NOTCH. NO TYPE OF MECHANICAL EXTENSION OR LEVER WILL BE USED. EXERCISE CARE DURING STRAP APPLICATION. AVOID "TWISTS" AND/OR "KNOTS" IN THE STRAP. THE STRAP MUST FORM A STRAIGHT "LAY" ON THE RATCHET TAKE-UP SPOOL WHEN TENSIONING. AFTER INITIAL WEBBING-TO-WEBBING CONTACT HAS BEEN MADE (ROTATING THE TAKE-UP SPOOL UNTIL NO METAL ON THE SPOOL IS SHOWING AND THE STRAP HAS MADE CONTACT WITH ITSELF), THE TENSIONED STRAP MUST FORM AT LEAST 1/2 BUT NO MORE THAN 1-1/2 WRAPS OF STRAP ON THE TAKE-UP SPOOL OF THE TENSIONING RATCHET. AFTER TENSIONING IS COMPLETED, ENSURE THAT THE SPOOL LOCKING LATCH IS FULLY SEATED AT BOTH ENDS OF THE SPOOL IN MATCHING LOCKING NOTCHES. TIE BACK THE LOOSE ENDS OF THE STRAP AFTER TENSIONING IS COMPLETED (LOOSE ENDS MAY BE FOLDED AND TAPED OR TIED TO THE TENSIONING STRAP).
- B. ADJUSTABLE SCUFF SLEEVES PROVIDED ON WEB STRAP ASSEMBLIES WILL BE LOCATED TO PROVIDE A PAD WHERE STRAPS PASS OVER SHARP EDGES, OR RATCHETS AND HOOKS ON PREVIOUSLY INSTALLED WEB STRAP TIEDOWN ASSEMBLIES.
- C. A STAGGERED NAILING PATTERN WILL BE USED WHENEVER POSSIBLE WHEN NAILS ARE DRIVEN INTO JOINTS OF DUNNAGE ASSEMBLIES OR WHEN LAMINATING DUNNAGE. ADDITIONALLY, THE NAILING PATTERN FOR AN UPPER PIECE OF LAMINATED DUNNAGE WILL BE ADJUSTED AS REQUIRED SO THAT A NAIL FOR THAT PIECE WILL NOT BE DRIVEN THROUGH, ONTO, OR RIGHT BESIDE A NAIL IN A LOWER PIECE.
- D. THE WEB STRAP RATCHETS SHOULD BE PLACED SYMMETRICALLY AROUND THE LOAD. FOR EXAMPLE, THE RATCHET FOR ONE STRAP ASSEMBLY SHOULD BE POSITIONED ON ONE SIDE OF THE VEHICLE AND THE RATCHET OF THE CORRESPONDING STRAP ASSEMBLY SHOULD BE POSITIONED ON THE OPPOSITE SIDE OF THE VEHICLE.
- E. LOADING OF 155MM SLP LOADS REQUIRES FORKLIFT WITH LATERAL SHIFT CAPABILITY. AT LEAST ONE PALLET UNIT ON BOTH THE TRUCK AND THE TRAILER WILL HAVE TO BE PLACED ON THE DECK AND LATERALLY MOVED INTO POSITION DUE TO INTERFERENCE FROM ONE OF THE POD SHOES (FORWARD RIGHT POD ON BOTH TRUCK AND TRAILER).
- F. THE STRAPS SECURING THE DUNNAGE ASSEMBLIES ON THE 155MM SLP LOADS MUST BE POSITIONED ABOVE AND CLEAR OF THE POD SHOES, TO PREVENT DAMAGE TO THE STRAPS.

MATERIAL SPECIFICATIONS

- LUMBER - - - - - : SEE TM 743-200-1 (DUNNAGE LUMBER) AND VOLUNTARY PRODUCT STANDARD PS 20.
- NAILS - - - - - : ASTM F1667; COMMON STEEL NAIL (NLCMS OR NLCMMS).
- STRAPPING, STEEL - - : ASTM D3953; FLAT STRAPPING, TYPE 1, HEAVY DUTY, FINISH A, B (GRADE 2), OR C.
- STRAP - - - - - : WEBBING, UNIVERSAL TIEDOWN, NSN 5340-01-204-3009, PN9392419, OR NSN 5340-01-089-4997, PN11669588, OR NSN 1670-00-725-1437, PN1376-013, OR NSN 5340-00-980-9277, PN10900880.
- SEAL, STRAP - - - - : ASTM D3953; CLASS H, FINISH A, B (GRADE 2), OR C, DOUBLE NOTCH TYPE, STYLE I, II, OR IV.

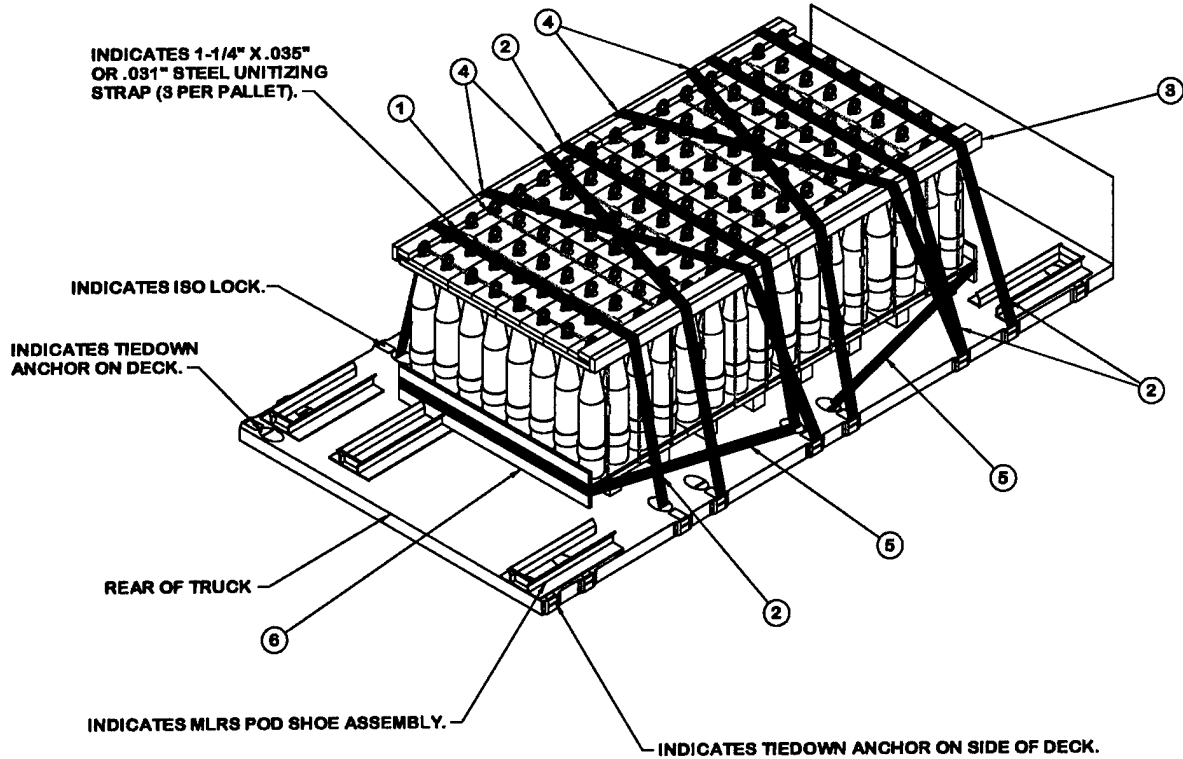

ISOMETRIC VIEW

KEY NUMBERS

- ① STEEL BUNDLING STRAP, 1-1/4" X .035" OR .031" (8 REQD). BUNDLE 4 PALLETS WITH 2 STRAPS. SEAL EACH STRAP WITH ONE SEAL CRIMPED WITH TWO PAIR OF NOTCHES.
 - ② WEB STRAP TIEDOWN ASSEMBLY (4 REQD).
 - ③ EDGE BOARD ASSEMBLY (4 REQD). SEE THE DETAIL ON PAGE 10.
 - ④ WEB STRAP TIEDOWN ASSEMBLY (4 REQD).
 - ⑤ WEB STRAP TIEDOWN ASSEMBLY (2 REQD). SEE GENERAL NOTE "F".
 - ⑥ DUNNAGE ASSEMBLY (2 REQD). SEE THE DETAIL ON PAGE 10.
- KEY NUMBERS ALSO INDICATE THE ORDER OF STRAP PLACEMENT.

TEST LOAD AS SHOWN

ITEM	QUANTITY	WEIGHT (APPROX)
PALLET UNIT	16	13,984 LBS
DUNNAGE		62 LBS
TOTAL WEIGHT		14,046 LBS (APPROX)

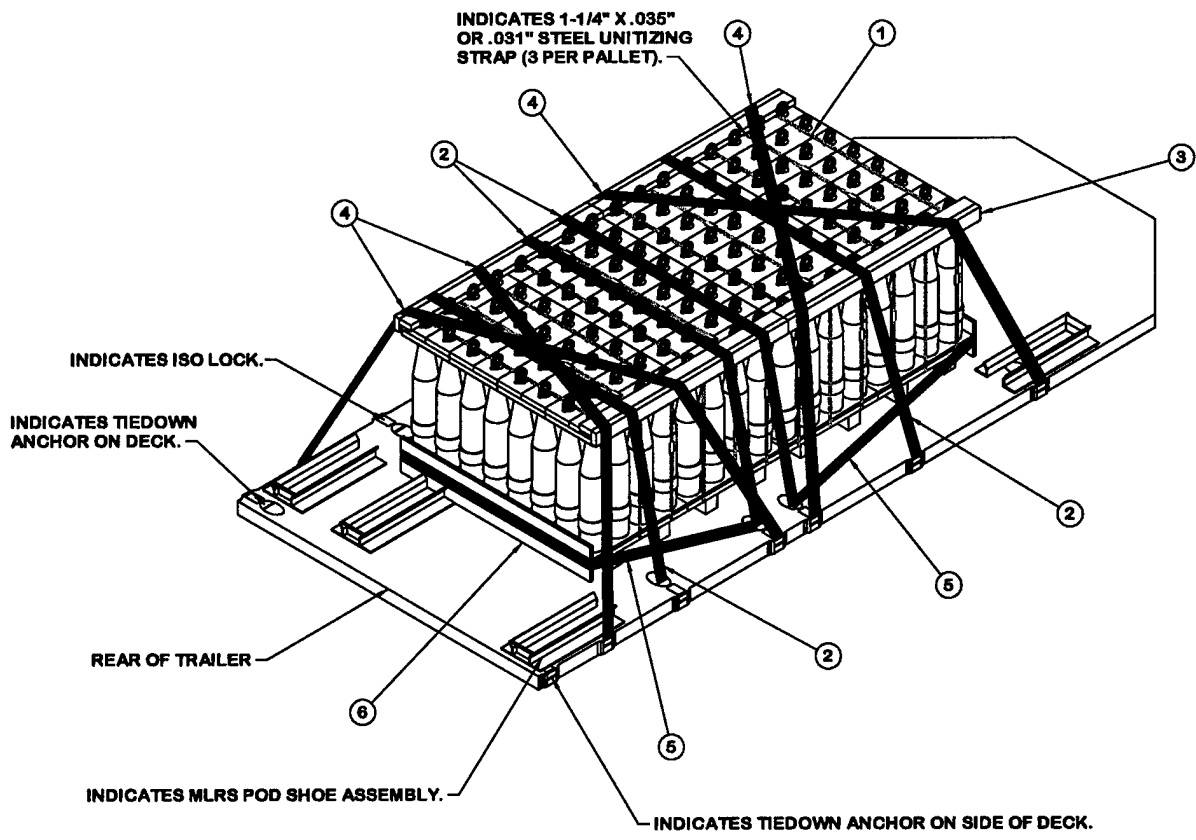

ISOMETRIC VIEW

KEY NUMBERS

- ① STEEL BUNDLING STRAP, 1-1/4" X .035" OR .031" (8 REQD). BUNDLE 4 PALLETS WITH 2 STRAPS. SEAL EACH STRAP WITH ONE SEAL CRIMPED WITH TWO PAIR OF NOTCHES.
 - ② WEB STRAP TIEDOWN ASSEMBLY (4 REQD).
 - ③ EDGE BOARD ASSEMBLY (4 REQD). SEE THE DETAIL ON PAGE 10.
 - ④ WEB STRAP TIEDOWN ASSEMBLY (4 REQD).
 - ⑤ WEB STRAP TIEDOWN ASSEMBLY (2 REQD). SEE GENERAL NOTE "F".
 - ⑥ DUNNAGE ASSEMBLY (2 REQD). SEE THE DETAIL ON PAGE 10.
- KEY NUMBERS ALSO INDICATE THE ORDER OF STRAP PLACEMENT.

TEST LOAD AS SHOWN

ITEM	QUANTITY	WEIGHT (APPROX)
PALLET UNIT	16	13,984 LBS
DUNNAGE		62 LBS
TOTAL WEIGHT		14,046 LBS (APPROX)

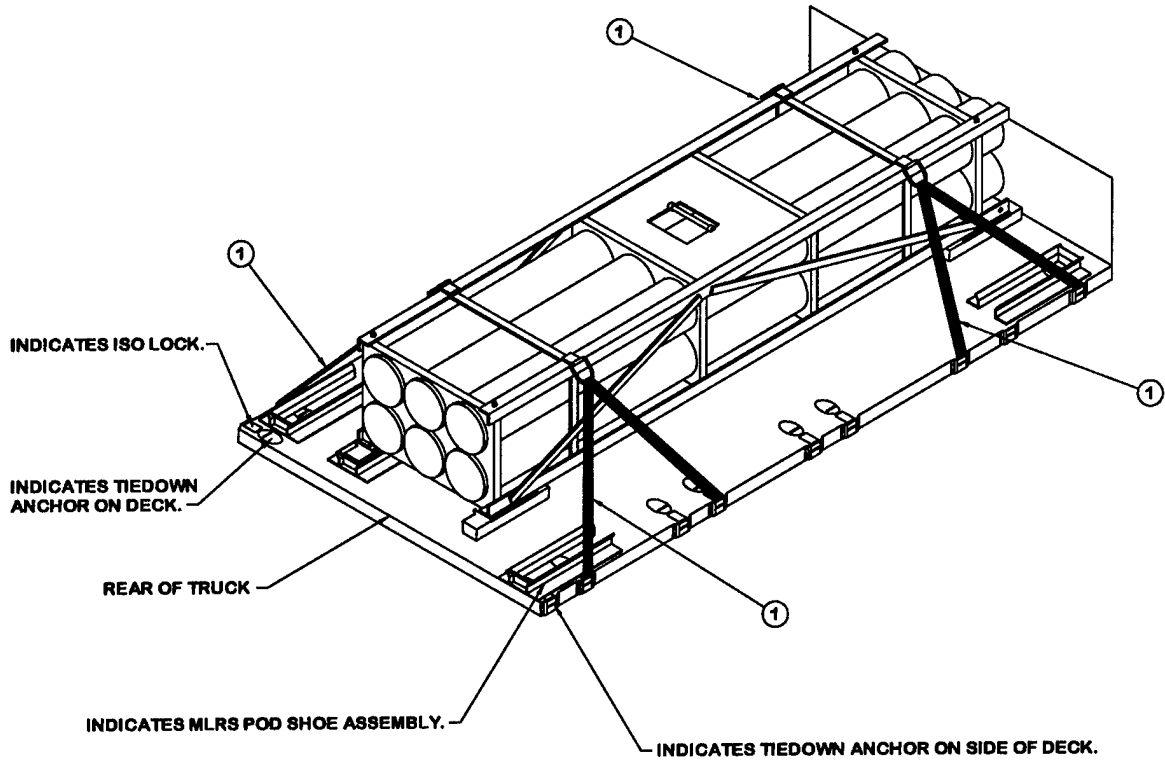

ISOMETRIC VIEW

KEY NUMBERS

① WEB STRAP TIEDOWN ASSEMBLY (4 REQD).

TEST LOAD AS SHOWN

<u>ITEM</u>	<u>QUANTITY</u>	<u>WEIGHT (APPROX)</u>
CONTAINER	----- 1 -----	5,078 LBS

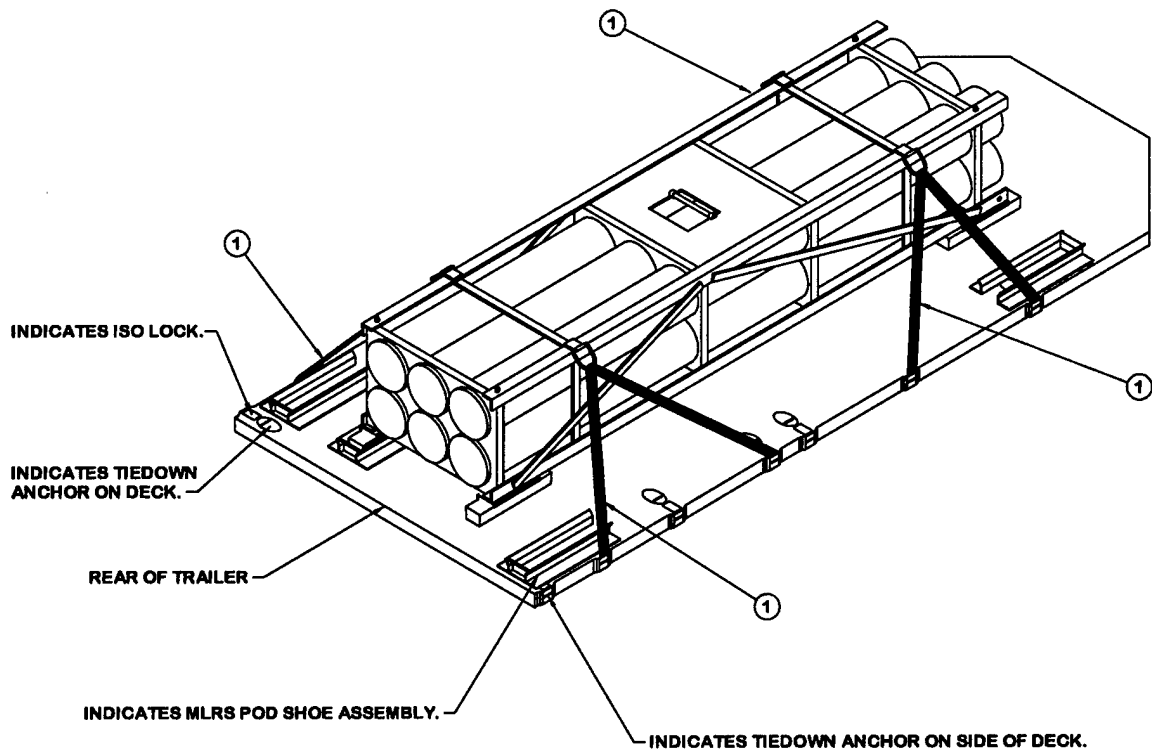

ISOMETRIC VIEW

KEY NUMBERS

① WEB STRAP TIEDOWN ASSEMBLY (4 REQD).

TEST LOAD AS SHOWN

<u>ITEM</u>	<u>QUANTITY</u>	<u>WEIGHT (APPROX)</u>
CONTAINER	1	5,078 LBS

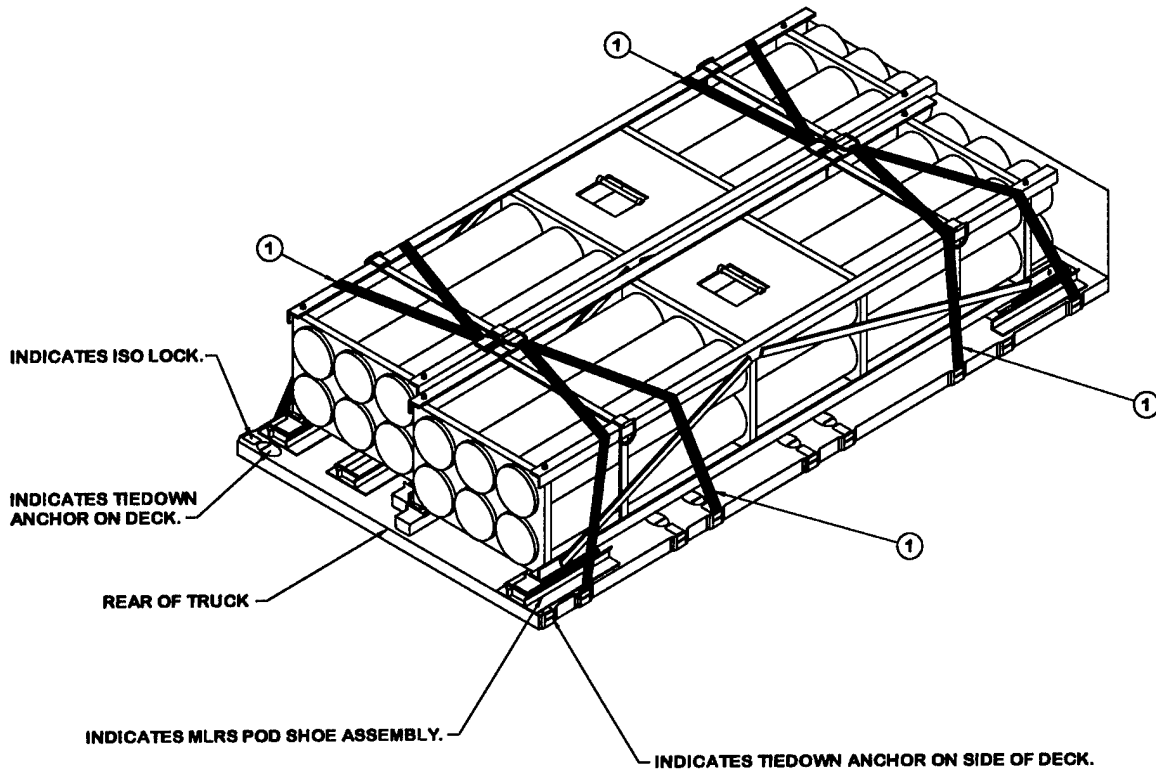

ISOMETRIC VIEW

KEY NUMBERS

- ① WEB STRAP TIEDOWN ASSEMBLY (4 REQD).

TEST LOAD AS SHOWN

<u>ITEM</u>	<u>QUANTITY</u>	<u>WEIGHT (APPROX)</u>
CONTAINER	----- 2 -----	10,156 LBS

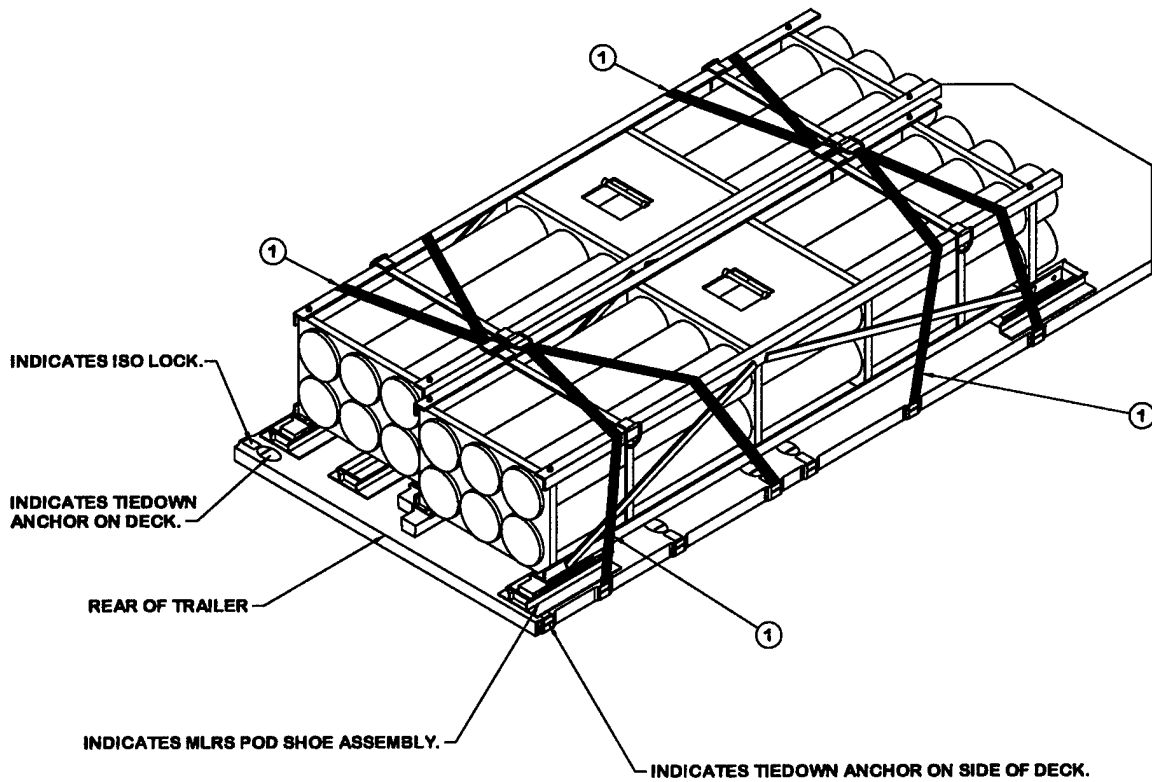

ISOMETRIC VIEW

KEY NUMBERS

① WEB STRAP TIEDOWN ASSEMBLY (4 REQD).

TEST LOAD AS SHOWN

<u>ITEM</u>	<u>QUANTITY</u>	<u>WEIGHT (APPROX)</u>
CONTAINER	2	10,156 LBS

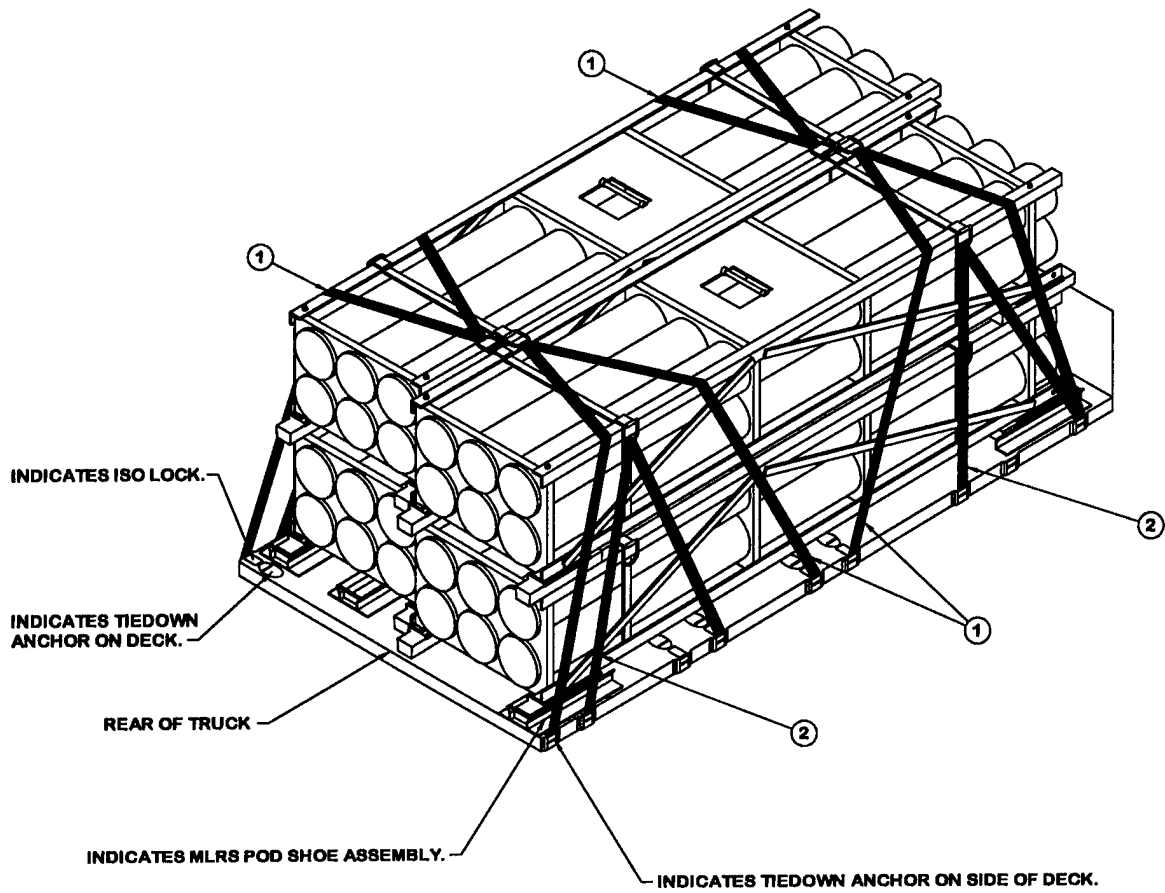

ISOMETRIC VIEW

KEY NUMBERS

- ① WEB STRAP TIEDOWN ASSEMBLY (4 REQD).
- ② WEB STRAP TIEDOWN ASSEMBLY (4 REQD).

TEST LOAD AS SHOWN

<u>ITEM</u>	<u>QUANTITY</u>	<u>WEIGHT (APPROX)</u>
CONTAINER	4	20,312 LBS

BEARING PIECE, 2" X 4" X 59" (1 REQD).

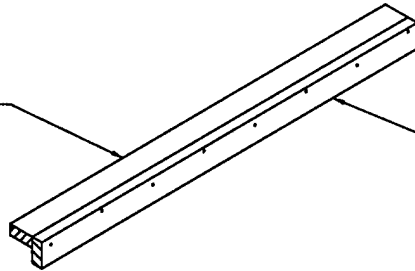

TIE PIECE, 2" X 4" X 59" (1 REQD).
NAIL TO THE BEARING PIECE W/10d
NAILS SPACED EVERY 8".

EDGE BOARD ASSEMBLY

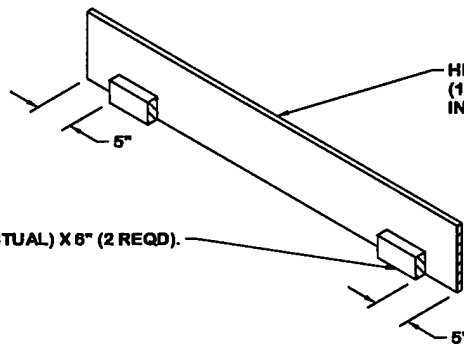

HEADER, 3/4" PLYWOOD, 9" X 58"
(1 REQD). NAIL THROUGH PLYWOOD
INTO EACH CLEAT W/2-8d NAILS.

RETAINER CLEAT, 2" X 3" (ACTUAL) X 6" (2 REQD).

DUNNAGE ASSEMBLY