

STINFO COPY United States Air Force Research Laboratory

The Effect of Tie-Down Geometry and Strap Angle on Personnel Restraint System Impact Dynamics

Benjamin C. Kuennen
John R. Buhrman
James W. Brinkley
John P. Kilian

AIR FORCE RESEARCH LABORATORY

November 2003

Final Report for the Period January to October 1978
and April to November 2003

BEST AVAILABLE COPY

*Approved for public release; distribution
is unlimited.*

**Human Effectiveness Directorate
Biosciences & Protection Division
Biomechanics Branch**
2800 Q Street, Bldg 824, Rm 206
Wright-Patterson AFB OH 45433-7947

ASC - 04 - 1499

NOTICES

When US Government drawings, specifications, or other data are used for any purpose other than a definitely related Government procurement operation, the Government thereby incurs no responsibility nor any obligation whatsoever, and the fact that the Government may have formulated, furnished, or in any way supplied the said drawings, specifications, or other data, is not to be regarded by implication or otherwise, as in any manner licensing the holder or any other person or corporation, or conveying any rights or permission to manufacture, use, or sell any patented invention that may in any way be related thereto.

Please do not request copies of this report from the Air Force Research Laboratory. Additional copies may be purchased from:

National Technical Information Service
5285 Port Royal Road
Springfield, Virginia 22161

Federal Government agencies registered with the Defense Technical Information Center should direct requests for copies of this report to:

Defense Technical Information Center
8725 John J. Kingman Rd., Ste 0944
Ft. Belvoir VA 22060-6218

TECHNICAL REVIEW AND APPROVAL

AFRL-HE-WP-TR-2004-0037

The voluntary informed consent of the subjects used in this research was obtained as required by Air Force Instruction 40-402.

This report has been reviewed by the Office of Public Affairs (PA) and is releasable to the National Technical Information Service (NTIS). At NTIS, it will be available to the general public, including foreign nations.

This technical report has been reviewed and is approved for publication.

FOR THE DIRECTOR

--Signed--

MARK M. HOFFMAN
Deputy Chief, Biosciences and Protection Division
Air Force Research Laboratory

REPORT DOCUMENTATION PAGE

Form Approved
OMB No. 0704-0188

The public reporting burden for this collection of information is estimated to average 1 hour per response, including the time for reviewing instructions, searching existing data sources, gathering and maintaining the data needed, and completing and reviewing the collection of information. Send comments regarding this burden estimate or any other aspect of this collection of information, including suggestions for reducing the burden, to Department of Defense, Washington Headquarters Services, Directorate for Information Operations and Reports (0704-0188), 1215 Jefferson Davis Highway, Suite 1204, Arlington, VA 22202-4302. Respondents should be aware that notwithstanding any other provision of law, no person shall be subject to any penalty for failing to comply with a collection of information if it does not display a currently valid OMB control number.

PLEASE DO NOT RETURN YOUR FORM TO THE ABOVE ADDRESS.

1. REPORT DATE (DD-MM-YYYY) 11-2003	2. REPORT TYPE Final	3. DATES COVERED (From - To) Jan-Oct 1978, Apr-Nov 2003
---	--------------------------------	---

4. TITLE AND SUBTITLE The Effect of Tie-Down Geometry and Strap Angle on Personnel Restraint System Impact Dynamics	5a. CONTRACT NUMBER
	5b. GRANT NUMBER
	5c. PROGRAM ELEMENT NUMBER 62202F

6. AUTHOR(S) Benjamin C. Kuennen, John R. Buhrman, James W. Brinkley, John P. Kilian	5d. PROJECT NUMBER 7184
	5e. TASK NUMBER 718402
	5f. WORK UNIT NUMBER /1840203

7. PERFORMING ORGANIZATION NAME(S) AND ADDRESS(ES) Air Force Research Laboratory, Human Effectiveness Directorate Biosciences and Protection Division Biomechanics Branch Air Force Materiel Command Wright-Patterson AFB OH 45433-7947	8. PERFORMING ORGANIZATION REPORT NUMBER AFRL-HE-WP-TR-2004-0037
---	--

9. SPONSORING/MONITORING AGENCY NAME(S) AND ADDRESS(ES)	10. SPONSOR/MONITOR'S ACRONYM(S)
	11. SPONSOR/MONITOR'S REPORT NUMBER(S)

12. DISTRIBUTION/AVAILABILITY STATEMENT Approved for public release; distribution is unlimited	20040722 056
--	---------------------

13. SUPPLEMENTARY NOTES

14. ABSTRACT Pilot size and gender have long been investigated to determine possible injury risks involved during cockpit ejections. Previous investigations focused more on the differences between the subjects themselves. In this study, the focus was on the relationship between the subject and the geometry of the restraint system. Four restraint configurations of varying shoulder strap angles and lap belt tie-down positions were used to determine the most and least favorable restraint geometries. Male and female subjects were exposed to frontal impact acceleration pulses using a horizontal impulse acceleration facility. Subject accelerations and resulting forces were measured and evaluated for comparison between the restraint configurations. No significant differences were found between the configurations, though trends discovered through linear regression indicated possible preferences in the restraint geometries.
--

15. SUBJECT TERMS Shoulder Strap Angle, Lap Belt Tie-Down, Impact Acceleration
--

16. SECURITY CLASSIFICATION OF:			17. LIMITATION OF ABSTRACT UL	18. NUMBER OF PAGES 51	19a. NAME OF RESPONSIBLE PERSON John R. Buhrman
a. REPORT UC	b. ABSTRACT UC	c. THIS PAGE UC			19b. TELEPHONE NUMBER (Include area code) 937-255-3121

THIS PAGE LEFT BLANK INTENTIONALLY

PREFACE

The impact tests and data analysis described in this report were accomplished by the Biomechanics Branch, Biosciences and Protection Division of the Air Force Research Laboratory (AFRL/HEPA), formerly called the Biomechanical Protection Branch, Biodynamics and Bioengineering Division of the Aerospace Medical Research Laboratory (AMRL/BBP), at Wright-Patterson Air Force Base, Ohio. The test program was originally funded under Workunit 72311602. The human subject use committee at Wright-Patterson AFB, Ohio, under Protocol 76-30, authorized approval for the use of human volunteers in this program. Dyncorp, formerly called Dynelectron Corporation, provided test facility and engineering support under contract F33615-76-C-0526.

THIS PAGE LEFT BLANK INTENTIONALLY

TABLE OF CONTENTS

	<u>PAGE</u>
INTRODUCTION.....	1
METHODS.....	1
RESULTS.....	4
DISCUSSION.....	8
CONCLUSIONS.....	10
REFERENCES.....	11
APPENDIX A. Statistical Comparisons Between Test Configurations.....	12
APPENDIX B. Sample Test Data.....	17
APPENDIX C. Impact Sled and Seat Configuration.....	42

LIST OF FIGURES

<u>FIGURE</u>	<u>PAGE</u>
1 Male Subject Prior to Impact Test on Horizontal Impulse Accelerator.....	2
2 Test Configurations.....	3
3 Head Acceleration Test Cell and Regression Plot.....	6
4 Chest Acceleration Test Cell and Regression Plot.....	6
5 Shoulder Strap Force Test Cell and Regression Plot.....	7
6 Lap Belt Force Test Cell and Regression Plot.....	7
7 Seat Pan Force Test Cell and Regression Plot.....	8

LIST OF TABLES

<u>TABLE</u>	<u>PAGE</u>
1 Test Cell Matrix.....	3
2 Means and Standard Deviations for 6 G Tests.....	4
3 Means and Standard Deviations for 8 G Tests.....	4
4 Means and Standard Deviations for 10 G Tests.....	4

INTRODUCTION

It has long been known that the proper use of safety restraining devices in aircraft can greatly reduce the risk of serious injury and even fatality in the event of a crash. The use of shoulder belts with lap belts could reduce major injuries by more than 85% and fatalities by 20% [3]. Numerous studies have also linked the improper use of safety belts and shoulder harnesses to injuries in cases of rapid deceleration.

Studies and investigations on fatal aircraft accidents led the Federal Aviation Administration (FAA) to require all new aircraft to have shoulder restraints installed in 1969. Head, neck, abdominal and chest trauma are the most critical to life. Even injury to the upper extremities can result in unnecessary loss of life if the individual is unable to evacuate the aircraft in an emergency, such as a post-crash fire or to avoid drowning. Roughly one third of the deaths in aviation accidents in the 1950's and 60's might have been avoided if shoulder restraints had been used [8].

The question arises as to whether merely having restraints is good enough or if there is a best way to configure the restraints. It has been shown that using a double shoulder harness system with lap belts is preferred over a single diagonal shoulder belt and a 3-point belt system with a single shoulder belt and lap belts [6,7]. The double harness prevents the torso from twisting out and around the single shoulder belt, significantly reducing the risk of injury. The distribution of applied loads to two belts is also greater than the same loads applied to a single belt, causing less stretching of the belt and greater restricted forward movement [9].

The FAA Office of Aviation Medicine reports that the optimum placement of the lap belt should result in an angle of about 55 degrees with the horizontal centerline of the airplane when it is tightened about the hips [3]. This allows it to resist the upward pull of the shoulder belts, reducing the risk of injury. Also, it has been noted that since the tie-down position of the lap belt ultimately determines the lap belt angle; the more forward the tie-down point is, the less the restraint function of the belt, possibly compromising the entire restraint system [9]. Both of the different lap belt configurations in this study fell within ± 5 degrees of this 55° angle.

This test program was conducted to determine the influence of the mechanical properties of restraint systems during impact. Specifically, the program evaluated the effects of changing the shoulder strap angle and lap belt tie-down points. It also provides biodynamic data for restraint design and dynamic test criteria.

METHODS

Eight males (158-210 lbs) and two females (116-123 lbs) were exposed to acceleration pulses at presumed sub-injury levels in the frontal -x axis using the AFRL Horizontal Impulse Accelerator (HIA) shown in Figure 1 [2]. The pulses were approximately sinusoidal with duration of 200 ms and rise time of 100 ms. The subjects were tested at seat accelerations of 6, 8, and 10 G. The subjects were volunteer members of the Aerospace Medical Research Laboratory (AMRL)

hazardous duty panel and were medically qualified for impact acceleration stress experiments through completion of a medical screening process more stringent than the USAF Flying Class II evaluation. Prior to testing, subjects were fully briefed regarding both the medical risks and the nature of the test program.



Figure 1. Male Subject Prior to Impact Test on Horizontal Impulse Accelerator

The subjects were positioned in a generic seat fixture mounted on the HIA sled with seat back angle 13° aft of vertical and seat pan angle 6° above horizontal. Ballast was added to the sled to ensure the same total sled/subject weight for each test. A flat headrest was mounted in-line with the seat back. The subjects were restrained using an operational USAF HBU-2 lap belt and a shoulder harness constructed of polyester webbing with either single-V or single-T shoulder strap connection. The shoulder straps and lap belt were pretensioned to $10, 20, \text{ or } 30 \pm 5$ lbs at each attachment point just prior to each test. Each subject wore cut-off long underwear, with males also wearing athletic supporters and females wearing two-piece bathing suits and undergarments. No helmet was worn and no limb restraints were used.

The subjects were tested under four different restraint configurations, consisting of combinations of two different lap belt tie-down positions and two shoulder harness angles. The zero reference point for the lap belt tie-down was set at 3 inches aft of the intersection of the seat back and seat pan. The subjects were also tested with the lap belt tie-down set directly at the seat back/seat pan intersection point. The 0° shoulder harness angle was determined to be at 0° from horizontal as measured at the top of the shoulder (near parallel to the ground). A 25° shoulder harness angle was also tested. Each test acceleration level included tests at zero tie-down reference point with 0° harness angle (Cell 1), 3 inches forward of zero tie-down reference point with 0° harness angle (Cell 2), zero tie-down reference point with 25° harness angle (Cell 5), and 3 inches forward of zero tie-down reference point with 25° harness angle (Cell 6). This test cell matrix is shown in Table 1. These configurations are shown in Figure 2.

Triaxial linear accelerometers were mounted to monitor accelerations of the sled, head and chest. Strain gauge load cells were used to measure the loads on the seat pan, shoulder straps, and lap belts. High-speed motion picture cameras recorded the tests in both the Y-axis and at a 45° angle between the Y- and X-axes.

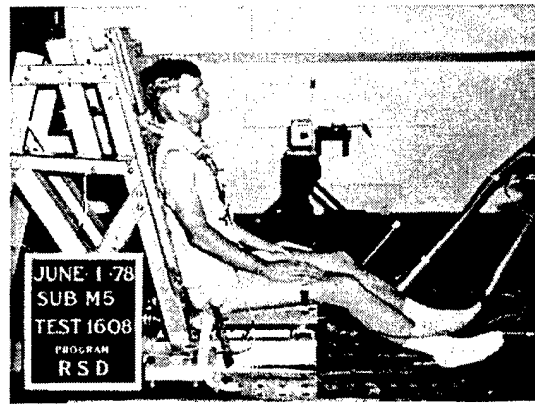
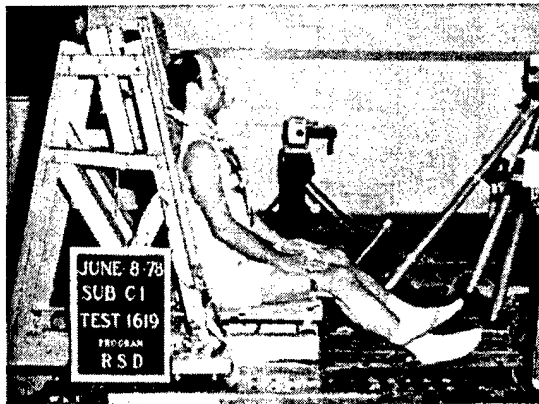
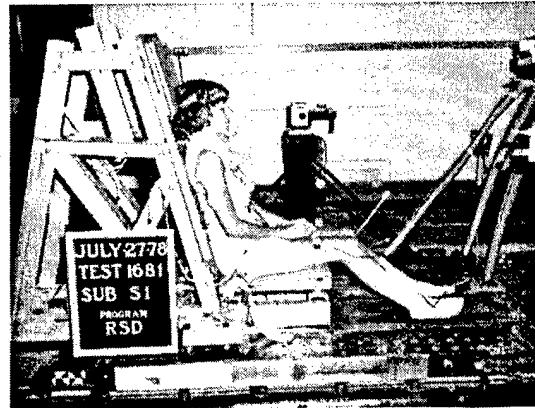
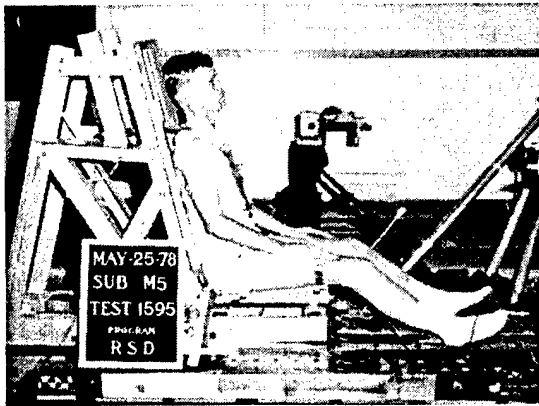

Figure 2. Test Configurations. Clockwise from top left: Zero tie-down reference point/0° harness angle (Cell 1); 3 inches forward of zero tie-down reference point/0° harness angle (Cell 2); 3 inches forward of zero tie-down reference point/25° harness angle (Cell 6); Zero tie-down reference point/25° harness angle (Cell 5).

Table 1. Test Cell Matrix

TEST CELL	NOM G	LAP BELT TIE-DOWN LOCATION	SHOULDER HARNESS ANGLE (DEG)
A1	6	Zero reference point	0
A2	6	3 inches forward of zero ref point	0
A5	6	Zero reference point	25
A6	6	3 inches forward of zero ref point	25
B1	8	Zero reference point	0
B2	8	3 inches forward of zero ref point	0
B5	8	Zero reference point	25
B6	8	3 inches forward of zero ref point	25
C1	10	Zero reference point	0
C2	10	3 inches forward of zero ref point	0
C5	10	Zero reference point	25
C6	10	3 inches in front of zero ref point	25

RESULTS

The mean peak magnitude head and chest accelerations and seat pan, lap and shoulder force resultants are shown in Tables 2-4 for the corresponding 6, 8, and 10 G input accelerations at each restraint configuration. These results are adjusted to take into account any existing preloading at the moment of impact. The results are labeled according to the test cell matrix listed previously. Outliers in the original data were filtered out of these calculations by using the Grubb's test. Causes for these outliers range from not sending/receiving a value from the equipment to possible reversed polarity of the sensors. Some outliers in the load measurements were eventually included when it was determined that the cause of the difference was due more to the size of the subject than any problems in the way the particular test was conducted. Generally, these few data points were seen on the low end and were due to the smaller size of the female subjects at the 6 and 8 G tests. No such statistical outliers were found in the 10 G tests.

Table 2. Means and Standard Deviations for 6 G Tests

	A1	A2	A5	A6
Head X (G)	9.1 ± 1.8	8.9 ± 1.2	9.8 ± 2.7	8.7 ± 1.6
Head Z (G)	6.6 ± 3.8	5.2 ± 2.9	7.9 ± 2.0	6.6 ± 1.9
Chest Result (G)	10.7 ± 2.5	9.7 ± 0.4	10.2 ± 1.0	9.6 ± 0.8
Seat Pan R (lb)	829.1 ± 118.6	1026.7 ± 132.3	644.1 ± 126.3	824.1 ± 142.2
Lap Force R (lb)	912.6 ± 202.2	1161.1 ± 168.1	955.3 ± 264.0	1106.5 ± 266.1
Should Force R (lb)	484.0 ± 80.7	590.8 ± 156.1	502.2 ± 146.9	561.1 ± 175.5

Table 3. Means and Standard Deviations for 8 G Tests

	B1	B2	B5	B6
Head X (G)	12.9 ± 2.2	15.2 ± 3.5	13.0 ± 2.9	14.2 ± 3.0
Head Z (G)	10.1 ± 4.2	11.8 ± 5.0	9.3 ± 2.8	13.4 ± 4.0
Chest Result (G)	14.5 ± 2.1	15.4 ± 3.1	15.2 ± 3.0	12.6 ± 0.9
Seat Pan R (lb)	1044.2 ± 112.3	1303.2 ± 210.5	946.8 ± 210.7	1113.6 ± 175.9
Lap Force R (lb)	1396.3 ± 262.9	1570.5 ± 322.1	1376.9 ± 334.6	1499.3 ± 380.0
Should Force R (lb)	733.7 ± 112.9	776.6 ± 226.8	823.2 ± 187.7	818.2 ± 185.2

Table 4. Means and Standard Deviations for 10 G Tests

	C1	C2	C5	C6
Head X (G)	17.6 ± 4.0	21.6 ± 5.6	16.8 ± 4.6	20.0 ± 3.7
Head Z (G)	15.9 ± 5.8	16.3 ± 6.1	15.1 ± 7.3	16.3 ± 6.8
Chest Result (G)	20.3 ± 5.6	15.5 ± 1.3	17.1 ± 2.4	15.8 ± 1.2
Seat Pan R (lb)	1224.9 ± 218.5	1553.7 ± 267.8	1119.8 ± 186.2	1241.6 ± 234.6
Lap Force R (lb)	1599.8 ± 388.3	1864.1 ± 521.1	1629.7 ± 466.3	1723.0 ± 425.0
Should Force R (lb)	851.9 ± 241.9	973.5 ± 310.5	933.1 ± 198.0	1078.8 ± 267.9

Statistical comparisons between the various cells in each $-G_x$ level run are listed in Appendix A. Of the 108 separate comparisons, only nine produced statistically significant differences at $p = 0.05$ in the t-test. Of those nine statistical tests, six compared differences in the seat pan loads at

various input accelerations, two compared chest accelerations, and one showed a difference in lap belt forces.

The parameter of most interest is the Head X acceleration, since the values in this field are most directly related to injury of an individual with the potential of being life altering (death or paralysis). The peak acceleration for this measurement at each input acceleration level showed no statistically significant differences between any of the test configurations at $p = 0.05$. There was also no statistically significant indication of increase or decrease in head acceleration in the X plane for any of the changes in configurations.

Linear regressions, calculated and plotted using the statistical program *ProStat v.2.5*, are shown in Figures 3-7. The plots in general indicate linear increasing accelerations and forces with increasing sled acceleration levels. Comparing the different configurations at the three input accelerations (Tables 2-4) indicates a possible tendency for higher Head X acceleration with the lap belt tie-down positioned at the 3" forward tie-down point (seat back/seat pan intersection) compared to the zero tie-down reference point (3" aft of seat back/seat pan intersection). At the 10 G level, Cell 2 (3" forward tie-down, 0° harness angle) was 23% higher than Cell 1 (zero tie-down ref point, 0° harness angle), and Cell 6 (3" forward tie-down, 25° harness angle) was 19% higher than Cell 5 (zero tie-down ref point, 25° harness angle) for Head X acceleration.

Also, there is an indication that the head acceleration is reduced somewhat when the shoulder straps are at a slight angle above the horizontal from the apex of the subject's shoulder, in this case 25°. At the 10 G level, Cell 5 (25° harness angle, zero tie-down ref point) was 4.5% lower than Cell 1 (0° harness angle, zero tie-down ref point), and Cell 6 (25° harness angle, 3" forward tie-down) was 7.4% lower than Cell 2 (0° harness angle, 3" forward tie-down) for Head X acceleration. Seat pan loads also were lower with the 25° harness angle, decreasing 9% from Cell 1 to Cell 5, and 20% from Cell 2 to Cell 6. Shoulder loads were higher with the 25° angle, increasing by 10% from Cell 1 to Cell 5, and 11% from Cell 2 to Cell 6.

The Chest Acceleration was the only one of the six parameters reported here to have tests with the zero tie-down ref point (Cells 1 and 5) indicate a greater magnitude than with the 3" forward tie-down point (Cells 2 and 6), as can be seen in Figures 3-7 and Tables 2-4. Table 4 indicates that Chest Acceleration in Cell 1 was 24% larger than Cell 2 at the 10 G level, and 8% greater in Cell 5 than Cell 6. This indicates that having the lap belt anchored in a more forward position may reduce the overall chest acceleration. The magnitude of the other five parameters all increased with the 3" forward tie-down position (Cells 2 and 6) compared to the zero tie-down ref point (Cells 1 and 5). The Seat Pan Force at 10 G was 27% larger in Cell 2 than Cell 1, and 11% larger in Cell 6 than Cell 5. The Lap Force at 10 G was 17% larger in Cell 2 than Cell 1, and 6% larger in Cell 6 than Cell 5. The Shoulder Force at 10 G was 14% larger in Cell 2 than Cell 1, and 16% larger in Cell 6 than Cell 5.

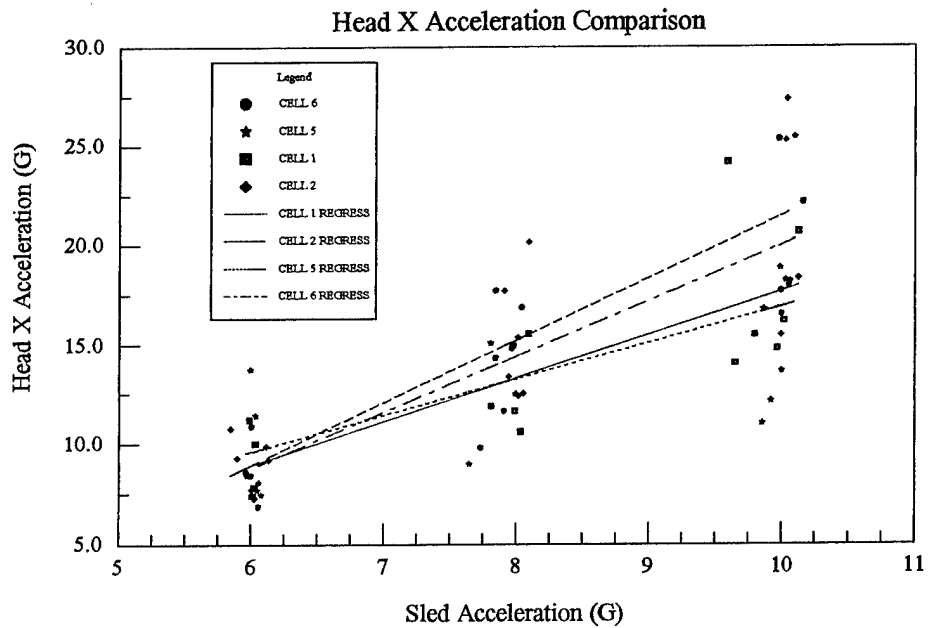

Figure 3. Head Acceleration Test Cell and Regression Plot

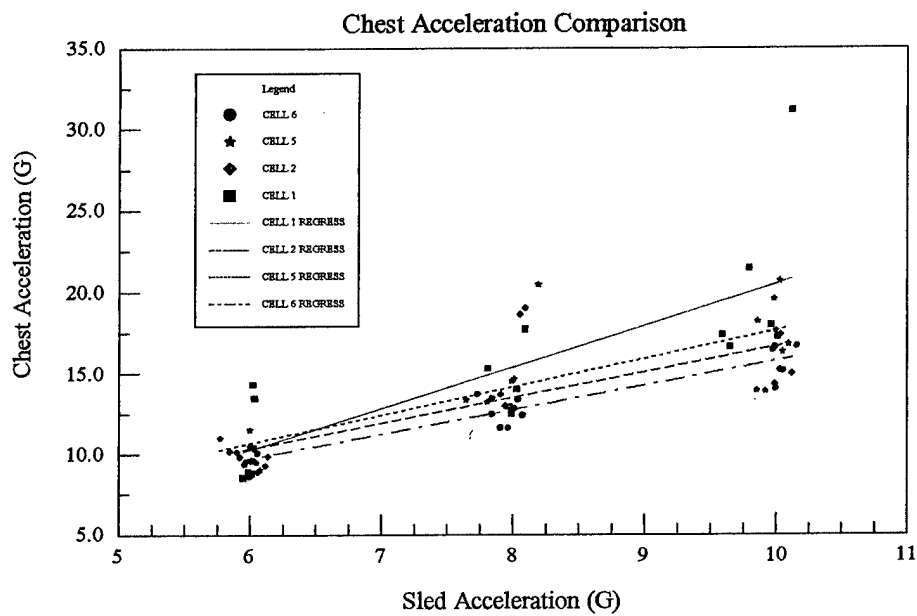

Figure 4. Chest Acceleration Test Cell and Regression Plot

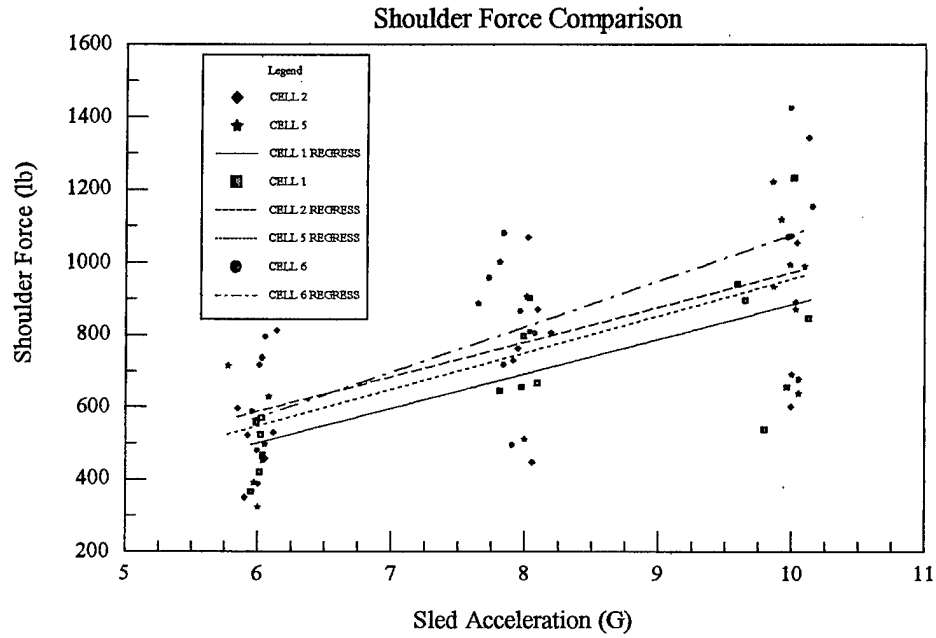

Figure 5. Shoulder Strap Force Test Cell and Regression Plot

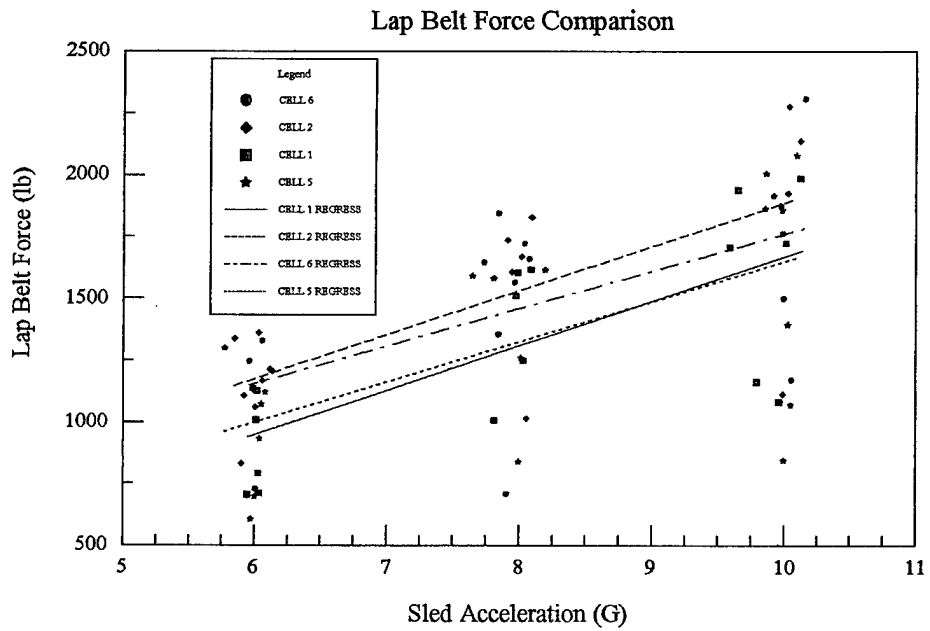

Figure 6. Lap Belt Force Test Cell and Regression Plot

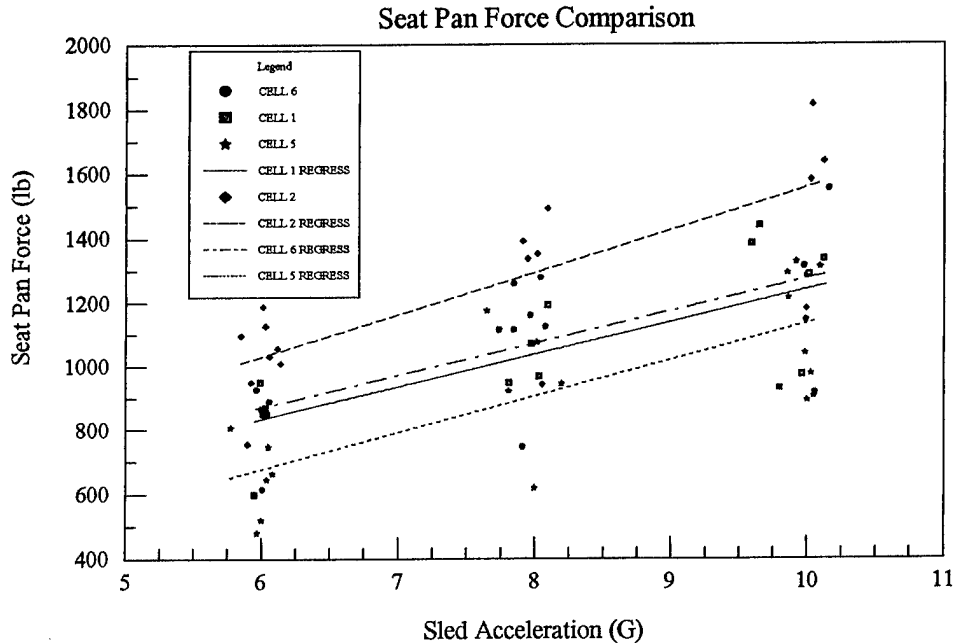

Figure 7. Seat Pan Force Test Cell and Regression Plot

DISCUSSION

Previous research has shown no significant effect on upper torso response to acceleration due to size or gender [1]. However, due to the small sample size of this test program, it cannot be determined from the available data whether subject size, gender, or neck strength had any significant effect on head acceleration. These issues will be addressed in future work at AFRL.

The data from Head X acceleration measurements show (see Appendix B), in general, two separate peaks. The likely explanation for this is that the body and head are going through two different accelerations. The first part of the acceleration is at the moment of impact and the body, most noticeably the chest, separates from the seat back. The secondary acceleration occurs when the restraints stop this separation movement and catch the body. In regards to the head accelerations, the first is consistent with the rest of the body. The second acceleration occurs as the chest is caught by the shoulder harness and the head continues to move relative to the body. In some instances this secondary acceleration is actually higher than the original acceleration. Though it was not measured in this study, it is also likely that this secondary head motion would have an increased rotational moment about the neck, which is where injury is more likely to occur.

While measuring the linear acceleration of the head is important for this study, it has been documented that acceleration itself does not necessarily directly correlate to an increased risk of injury. Rather it is the degree of neck hyperextension that will give a better indication of the risk of injury [4]. Nonetheless, the tendency for higher Head X acceleration with the lap belt tie-down positioned at the 3" forward mark (seat back/seat pan intersection) would appear to indicate potentially higher neck loads along with a greater risk of neck injury for this condition.

However, the tendency for higher head acceleration was mitigated somewhat when the shoulder straps were at a slight angle above the horizontal from the apex of the subject's shoulder. Test configurations with a 25° shoulder harness angle generated 15% greater shoulder strap loads, possibly indicative of better upper torso restraint which could have contributed to the reduction in head accelerations.

The configuration with 3" forward lap belt tie-down and 0° harness angle (Cell 2) generated the highest seat pan loads, while the configuration with the zero lap belt tie-down reference point (3" aft of seat pan/seat back intersection) and 25° harness angle (Cell 5) generated the lowest seat pan loads. In terms of vector geometry, these two configurations are at opposite ends with Cell 2 providing the most downward directed forces from both the lap and shoulder restraints while Cell 5 has the least downward directed forces of the four. Size of the test subjects can probably be ruled out as a factor since both of these configurations had about the same sample population. Configurations with the 3" forward tie-down also generated higher lap and shoulder forces.

It cannot presently be determined from the limited number of data points for each test cell why the chest acceleration increases at the zero tie-down point, while the head acceleration and shoulder/lap belt forces are reduced. This could be an anomalous occurrence for these test conditions, or there could be an actual physical reason. Further testing with better controls on the test environment and/or computer modeling could provide a clearer reason for these results.

An investigation of the shoulder and lap belt preloads, defined as the amount of tension applied to the straps when they are being tightened just prior to a test, showed that while there was a great deal of variability between each of the test runs, there was no discernible pattern to the loading. The loads typically ranged between 15 and 35 pounds for both the shoulder and the lap belts. These values were consistent across all of the different test configurations at the various impact levels with the preloads within each test cell reflecting the entire range of values.

In nearly all of the test runs, the video data showed that the subjects moved significantly in the seat upon impact across the entire range of impact accelerations. A visual estimate of several inches is observed between the shoulder blades and the seat back before the shoulder harness fully stops the subject. Similar motion and separation were observed between the hips and the seat back. This translational movement, however, was not recorded in the data.

It was also observed from the video data, though not recorded in the acceleration or force data, that subjects submarined during four of the test runs. This means that the lap belt rode up to or over one or both of the iliac crests (conversely, the hip moves under the belt), applying force to the abdominal area [5]. Two were in Cell C5 and one each in cells A5 and C1, indicating that the configuration most likely resulting in submarining is with the lap belt at the zero tie-down reference point and a 25° shoulder harness angle. The same female subject was involved in two of these events (cells C5 and C1), while the other two were both males. Even though only four of the tests showed obvious signs of submarining, nearly all of the tests showed the hips rotating down around the lap belt to some degree.

The observed submarine effect occurred primarily at higher accelerations. In all four instances the lap belt was anchored at the zero reference point (3" aft of the seat back/seat pan

intersection). It is possible that this geometry directs the force of the lap belt more into the hips than down into the lap, causing the hips to rotate more. Another cause could be attributed to the overall movement of the subject, as there was slack inherent in the restraints despite preloading the restraint straps. Perhaps tighter restraints would have limited the degree of motion, thus reducing the submarining.

CONCLUSIONS

The data consistently indicate that the preferred restraint configuration during these tests was with the lap belt tie-down point at 3" aft of the seat back/seat pan intersection (zero reference point) and the shoulder harness angle at some inclination above the horizontal from the shoulder of the person in the seat. This does not, however, necessarily mean that the 25° harness angle used in these tests is the optimum angle, only that it is preferred over the 0° angle. Such a configuration appears to minimize the seat pan loads and the more important head accelerations. Conversely, the least desirable configuration with respect to minimizing the head acceleration appears to be with the lap belt tie-down point three inches in front of the reference point (at the seat back/seat pan intersection) and the shoulder harness angle at or near the horizontal plane.

There is a limiting factor in this configuration. It appears as though having the lap belt tie-down three inches in front of the reference point (at the seat pan/seat back intersection) reduces the potential for submarining. Because of the small sample sizes for these configurations, it cannot be determined if the submarine effects are a true concern or if they are merely anomalies in the test setup. Also, it could not be determined whether the submarining was due in part to the occupant size since all but two of the test subjects were males weighing between 158-210 lbs. Eventually there does need to be a determination on the trade-off between submarining and other risk factors such as head acceleration.

It is important to note that the conclusions presented here are based on small test populations, and are only possible trends. In order to more accurately predict the outcomes of the different configurations, more tests would be needed with a much larger population sample for each of the tests. Also, from the data collected it was not clear if there was any active preloading by the subjects, such as bracing for the impending impact. In any future study, the bracing should be as consistent as possible to get a true representation of the differences in the configurations.

REFERENCES

1. Buhrman J.R., and Perry C.E. A Comparison of Male and Female Acceleration Responses During Laboratory Frontal -Gx Axis Impact Tests, AFRL-HE-WP-TR-2001-0022, Wright-Patterson AFB, OH, 2000.
2. Shaffer J.T. The Impulse Accelerator: An Impact Sled Facility for Human Research and Safety Systems Testing, Armstrong Medical Research Laboratory Report No. AMRL-TR-76-8, Wright-Patterson AFB, OH, 1976.
3. Smart Protection in Small Airplanes, Federal Aviation Administration's Civil Aeromedical Institute Publication AM-400-91/2, Oklahoma City, OK, 1991.
4. Clarke T.D., Gragg C.D., Sprouffske J.F., Trout E.M., Zimmerman R.M., and Muzzy W.H. Human Head Linear and Angular Accelerations During Impact, Biomechanics of Impact and Injury Tolerances of the Head-Neck Complex, Society of Automotive Engineers, pp. 87-104, 1993.
5. Patrick L.M., and Trosien K.R. Volunteer, Anthropometric Dummy, and Cadaver Responses with Three and Four Point Restraints, Biomechanics of Impact Injury and Injury Tolerances of the Thorax-Shoulder Complex, Society of Automotive Engineers, pp.105-129, 1994.
6. Snyder R.G., Snow C.C., Young J.W., Crosby W.M., and Price G.T. Pathology of Trauma Attributed to Restraint Systems in Crash Impacts, FAA AM-69-03, Oklahoma City, OK, 1969.
7. Snyder R.G., Snow C.C., Young J.W., Crosby W.M., and Hanson P. Seat Belt Injuries on Impact, FAA AM-69-05, Oklahoma City, OK, 1969.
8. Sirkis J.A. The Benefits of the Use of Shoulder Harnesses in General Aviation Aircraft, FAA-AM-72-3, Washington, D.C., 1972.
9. Young J.W. A Functional Comparison of Basic Restraint Systems, FAA-AM-67-13, Oklahoma City, OK, 1967.

APPENDIX A

STATISTICAL COMPARISONS BETWEEN TEST CONFIGURATIONS

Table A1. T-test Comparison of Cells A1 and A2

	A1	A2	% DIFF	SIGNIF
Head X (G)	9.1125 ± 1.8015	8.8972 ± 1.2445	-1 %	NSD
Head Z (G)	-6.62 ± 3.77	-5.22 ± 2.89	+21 %	NSD
Chest Result (G)	10.75 ± 2.54	9.694 ± 0.431	-10 %	NSD
Seat Pan R (lb)	829.1 ± 118.6	1026.7 ± 132.3	+24 %	P = 0.01
Lap Force R (lb)	912.6 ± 202.2	1161.1 ± 168.1	+27 %	P = 0.03
Should Force R (lb)	484.0 ± 80.7	590.8 ± 156.1	+22 %	NSD

Table A2. T-test Comparison of Cells A1 and A5

	A1	A5	% DIFF	SIGNIF
Head X (G)	9.1125 ± 1.8015	9.7559 ± 2.7342	+7 %	NSD
Head Z (G)	-6.62 ± 3.77	-7.90 ± 2.04	-19 %	NSD
Chest Result (G)	10.75 ± 2.54	10.16 ± 0.97	-5 %	NSD
Seat Pan R (lb)	829.1 ± 118.6	644.1 ± 126.3	-22 %	P = 0.03
Lap Force R (lb)	912.6 ± 202.2	955.3 ± 264.0	+5 %	NSD
Should Force R (lb)	484.0 ± 80.7	502.2 ± 146.9	+4 %	NSD

Table A3. T-test Comparison of Cells A1 and A6

	A1	A6	% DIFF	SIGNIF
Head X (G)	9.1125 ± 1.8015	8.7039 ± 1.6501	-4 %	NSD
Head Z (G)	-6.62 ± 3.77	-6.62 ± 1.89	0 %	NSD
Chest Result (G)	10.75 ± 2.54	9.627 ± 0.812	-10 %	NSD
Seat Pan R (lb)	829.1 ± 118.6	824.1 ± 142.2	-1 %	NSD
Lap Force R (lb)	912.6 ± 202.2	1106.5 ± 266.1	+21 %	NSD
Should Force R (lb)	484.0 ± 80.7	561.1 ± 175.5	+16 %	NSD

Table A4. T-test Comparison of Cells A2 and A5

	A2	A5	%DIFF	SIGNIF
Head X (G)	8.8972 ± 1.2445	9.7559 ± 2.7342	+10%	NSD
Head Z (G)	-5.22 ± 2.89	-7.90 ± 2.04	-51%	NSD
Chest Result (G)	9.694 ± 0.431	10.16 ± 0.97	+5%	NSD
Seat Pan R (lb)	1026.7 ± 132.3	644.1 ± 126.3	-63%	P = 0.0001
Lap Force R (lb)	1161.1 ± 168.1	955.3 ± 264.0	-18%	NSD
Should Force R (lb)	590.8 ± 156.1	502.2 ± 146.9	-15%	NSD

Table A5. T-test Comparison of Cells A2 and A6

	A2	A6	%DIFF	SIGNIF
Head X (G)	8.8972 ± 1.2445	8.7039 ± 1.6501	-2%	NSD
Head Z (G)	-5.22 ± 2.89	-6.62 ± 1.89	-27%	NSD
Chest Result (G)	9.694 ± 0.431	9.627 ± 0.812	-1%	NSD
Seat Pan R (lb)	1026.7 ± 132.3	824.1 ± 142.2	-20%	P = 0.03
Lap Force R (lb)	1161.1 ± 168.1	1106.5 ± 266.1	-5%	NSD
Should Force R (lb)	590.8 ± 156.1	561.1 ± 175.5	-5%	NSD

Table A6. T-test Comparison of Cells A5 and A6

	A5	A6	%DIFF	SIGNIF
Head X (G)	9.7559 ± 2.7342	8.7039 ± 1.6501	-11%	NSD
Head Z (G)	-7.90 ± 2.04	-6.62 ± 1.89	+16%	NSD
Chest Result (G)	10.16 ± 0.97	9.627 ± 0.812	-5%	NSD
Seat Pan R (lb)	644.1 ± 126.3	824.1 ± 142.2	+28%	NSD
Lap Force R (lb)	955.3 ± 264.0	1106.5 ± 266.1	+16%	NSD
Should Force R (lb)	502.2 ± 146.9	561.1 ± 175.5	+12%	NSD

Table A7. T-test Comparison of Cells B1 and B2

	B1	B2	%DIFF	SIGNIF
Head X (G)	12.90 ± 2.19	15.23 ± 3.51	+18%	NSD
Head Z (G)	-10.08 ± 4.16	-11.77 ± 4.97	-17%	NSD
Chest Result (G)	14.49 ± 2.10	15.4 ± 3.1	+6%	NSD
Seat Pan R (lb)	1044.2 ± 112.3	1303.2 ± 210.5	+25%	NSD
Lap Force R (lb)	1396.3 ± 262.9	1570.5 ± 322.1	+12%	NSD
Should Force R (lb)	733.7 ± 112.9	776.6 ± 226.8	+6%	NSD

Table A8. T-test Comparison of Cells B1 and B5

	B1	B5	%DIFF	SIGNIF
Head X (G)	12.90 ± 2.19	12.98 ± 2.95	+1%	NSD
Head Z (G)	-10.08 ± 4.16	-9.33 ± 2.77	+7%	NSD
Chest Result (G)	14.49 ± 2.10	15.2 ± 3.0	+5%	NSD
Seat Pan R (lb)	1044.2 ± 112.3	946.8 ± 210.7	-9%	NSD
Lap Force R (lb)	1396.3 ± 262.9	1376.9 ± 334.6	-1%	NSD
Should Force R (lb)	733.7 ± 112.9	823.2 ± 187.7	+12%	NSD

Table A9. T-test Comparison of Cells B1 and B6

	B1	B6	%DIFF	SIGNIF
Head X (G)	12.90 ± 2.19	14.16 ± 3.01	+10%	NSD
Head Z (G)	-10.08 ± 4.16	-13.37 ± 4.05	-33%	NSD
Chest Result (G)	14.49 ± 2.10	12.65 ± 0.87	-13%	NSD
Seat Pan R (lb)	1044.2 ± 112.3	1113.6 ± 175.9	+7%	NSD
Lap Force R (lb)	1396.3 ± 262.9	1499.3 ± 380.0	+7%	NSD
Should Force R (lb)	733.7 ± 112.9	818.2 ± 185.2	+12%	NSD

Table A10. T-test Comparison of Cells B2 and B5

	B2	B5	%DIFF	SIGNIF
Head X (G)	15.23 ± 3.51	12.98 ± 2.95	-15%	NSD
Head Z (G)	-11.77 ± 4.97	-9.33 ± 2.77	+21%	NSD
Chest Result (G)	15.4 ± 3.1	15.2 ± 3.0	-1%	NSD
Seat Pan R (lb)	1303.2 ± 210.5	946.8 ± 210.7	-27%	P = 0.03
Lap Force R (lb)	1570.5 ± 322.1	1376.9 ± 334.6	-12%	NSD
Should Force R (lb)	776.6 ± 226.8	823.2 ± 187.7	+6%	NSD

Table A11. T-test Comparison of Cells B2 and B6

	B2	B6	%DIFF	SIGNIF
Head X (G)	15.23 ± 3.51	14.16 ± 3.01	-7%	NSD
Head Z (G)	-11.77 ± 4.97	-13.37 ± 4.05	-14%	NSD
Chest Result (G)	15.4 ± 3.1	12.65 ± 0.87	-18%	P = 0.05
Seat Pan R (lb)	1303.2 ± 210.5	1113.6 ± 175.9	-14%	NSD
Lap Force R (lb)	1570.5 ± 322.1	1499.3 ± 380.0	-5%	NSD
Should Force R (lb)	776.6 ± 226.8	818.2 ± 185.2	+5%	NSD

Table A12. T-test Comparison of Cells B5 and B6

	B5	B6	%DIFF	SIGNIF
Head X (G)	12.98 ± 2.95	14.16 ± 3.01	+9%	NSD
Head Z (G)	-9.33 ± 2.77	-13.37 ± 4.05	-43%	NSD
Chest Result (G)	15.2 ± 3.0	12.65 ± 0.87	-17%	P = 0.05
Seat Pan R (lb)	946.8 ± 210.7	1113.6 ± 175.9	+18%	NSD
Lap Force R (lb)	1376.9 ± 334.6	1499.3 ± 380.0	+9%	NSD
Should Force R (lb)	823.2 ± 187.7	818.2 ± 185.2	-1%	NSD

Table A13. T-test Comparison of Cells C1 and C2

	C1	C2	%DIFF	SIGNIF
Head X (G)	17.5619 ± 4.0002	21.6126 ± 5.6232	+23%	NSD
Head Z (G)	-15.9 ± 5.8	-16.3 ± 6.1	-3%	NSD
Chest Result (G)	20.3 ± 5.6	15.5 ± 1.3	-24%	NSD
Seat Pan R (lb)	1224.9 ± 218.5	1553.7 ± 267.8	+27%	NSD
Lap Force R (lb)	1599.8 ± 388.3	1864.1 ± 521.1	+17%	NSD
Should Force R (lb)	851.9 ± 241.9	973.5 ± 310.5	+14%	NSD

Table A14. T-test Comparison of Cells C1 and C5

	C1	C5	%DIFF	SIGNIF
Head X (G)	17.5619 ± 4.0002	16.7542 ± 4.5896	-5%	NSD
Head Z (G)	-15.9 ± 5.8	-15.1 ± 7.3	+5%	NSD
Chest Result (G)	20.3 ± 5.6	17.1 ± 2.4	-16%	NSD
Seat Pan R (lb)	1224.9 ± 218.5	1119.8 ± 186.2	-9%	NSD
Lap Force R (lb)	1599.8 ± 388.3	1629.7 ± 466.3	+2%	NSD
Should Force R (lb)	851.9 ± 241.9	933.1 ± 198.0	+10%	NSD

Table A15. T-test Comparison of Cells C1 and C6

	C1	C6	%DIFF	SIGNIF
Head X (G)	17.5619 ± 4.0002	19.98 ± 3.67	+14%	NSD
Head Z (G)	-15.9 ± 5.8	-16.34 ± 6.80	-3%	NSD
Chest Result (G)	20.3 ± 5.6	15.8 ± 1.2	-22%	NSD
Seat Pan R (lb)	1224.9 ± 218.5	1241.6 ± 234.6	+1%	NSD
Lap Force R (lb)	1599.8 ± 388.3	1723.0 ± 425.0	+8%	NSD
Should Force R (lb)	851.9 ± 241.9	1078.8 ± 267.9	+27%	NSD

Table A16. T-test Comparison of Cells C2 and C5

	C2	C5	%DIFF	SIGNIF
Head X (G)	21.6126 ± 5.6232	16.7542 ± 4.5896	-22%	NSD
Head Z (G)	-16.3 ± 6.1	-15.1 ± 7.3	+7%	NSD
Chest Result (G)	15.5 ± 1.3	17.1 ± 2.4	+10%	NSD
Seat Pan R (lb)	1553.7 ± 267.8	1119.8 ± 186.2	-28%	P = 0.01
Lap Force R (lb)	1864.1 ± 521.1	1629.7 ± 466.3	-13%	NSD
Should Force R (lb)	973.5 ± 310.5	933.1 ± 198.0	-4%	NSD

Table A17. T-test Comparison of Cells C2 and C6

	C2	C6	%DIFF	SIGNIF
Head X (G)	21.6126 ± 5.6232	19.98 ± 3.67	-8%	NSD
Head Z (G)	-16.3 ± 6.1	-16.34 ± 6.80	0%	NSD
Chest Result (G)	15.5 ± 1.3	15.8 ± 1.2	+2%	NSD
Seat Pan R (lb)	1553.7 ± 267.8	1241.6 ± 234.6	-20%	NSD
Lap Force R (lb)	1864.1 ± 521.1	1723.0 ± 425.0	-8%	NSD
Should Force R (lb)	973.5 ± 310.5	1078.8 ± 267.9	+11%	NSD

Table A18. T-test Comparison of Cells C5 and C6

	C5	C6	%DIFF	SIGNIF
Head X (G)	16.7542 ± 4.5896	19.98 ± 3.67	+19%	NSD
Head Z (G)	-15.1 ± 7.3	-16.34 ± 6.80	+8%	NSD
Chest Result (G)	17.1 ± 2.4	15.8 ± 1.2	-8%	NSD
Seat Pan R (lb)	1119.8 ± 186.2	1241.6 ± 234.6	+11%	NSD
Lap Force R (lb)	1629.7 ± 466.3	1723.0 ± 425.0	+6%	NSD
Should Force R (lb)	933.1 ± 198.0	1078.8 ± 267.9	+16%	NSD

APPENDIX B
SAMPLE TEST DATA

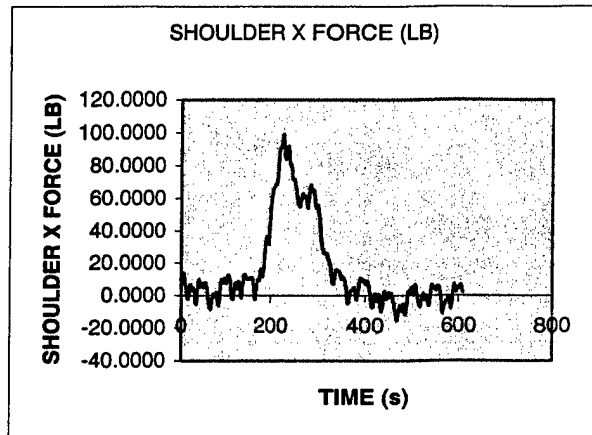
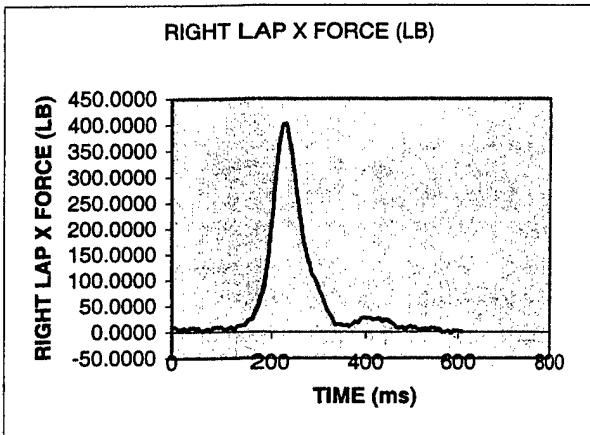
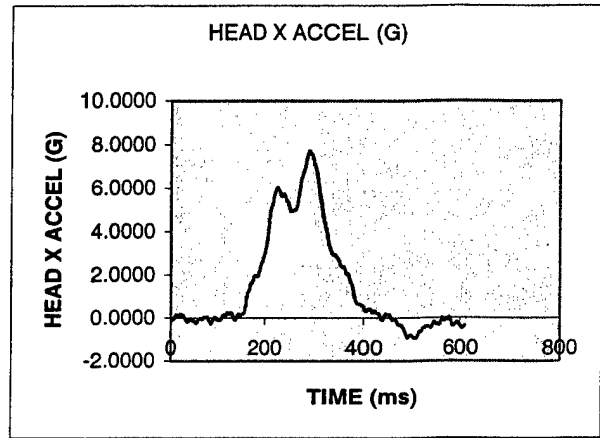
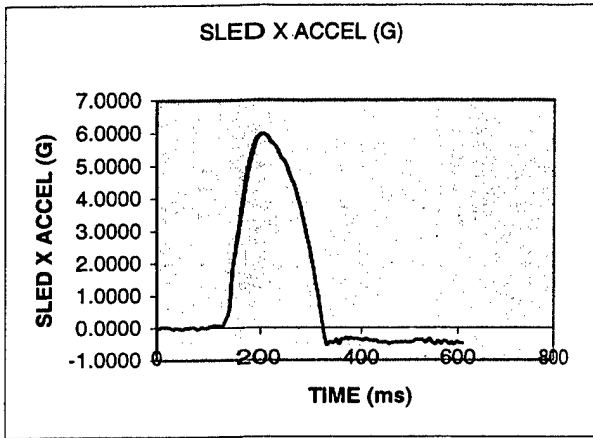
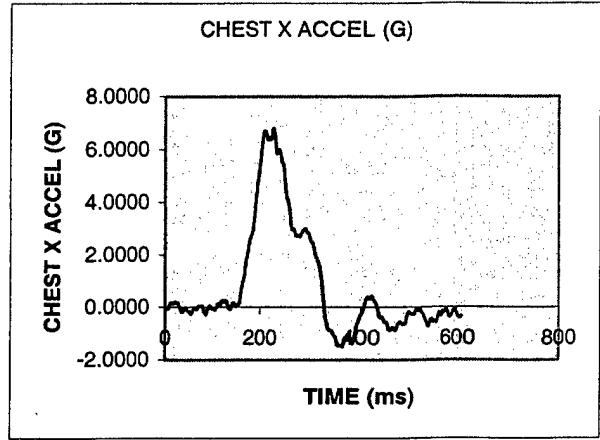
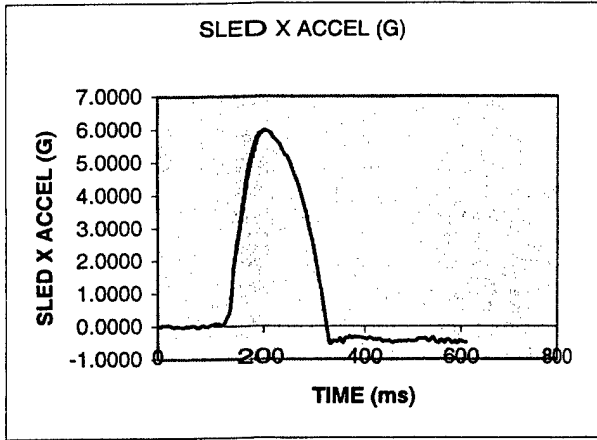

Test Subject HIA 1642 Cell A1

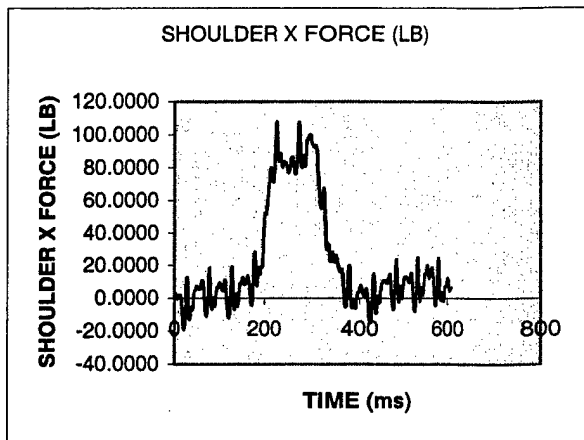
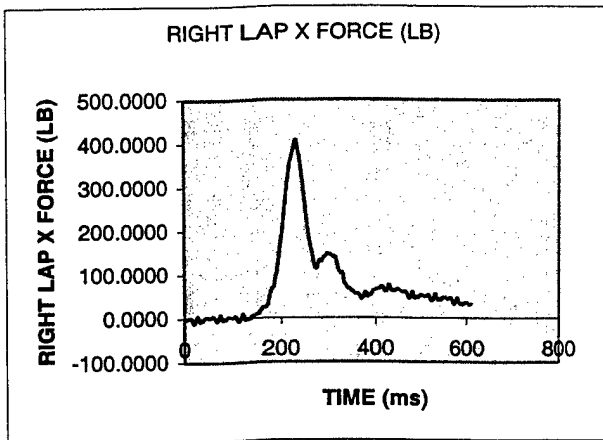
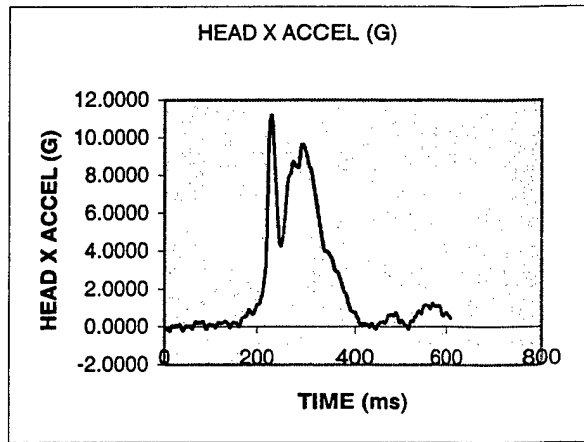
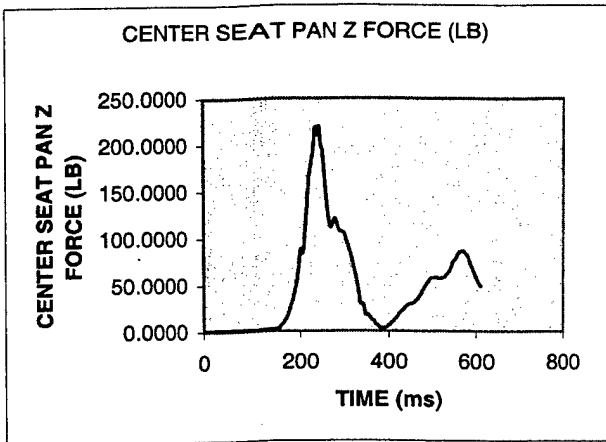
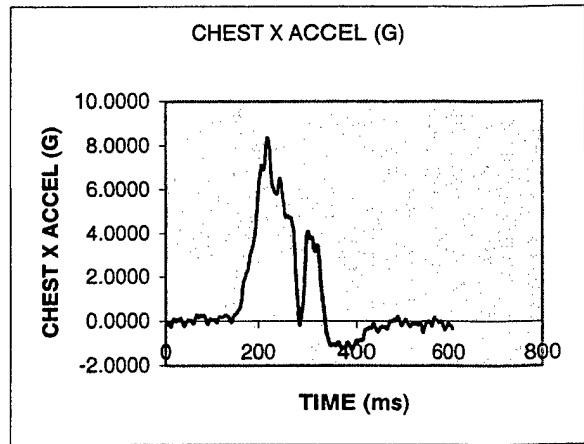
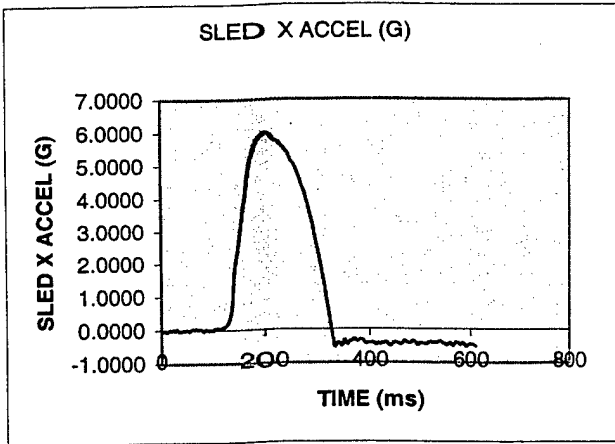

Test Subject HIA 1653 Cell A1

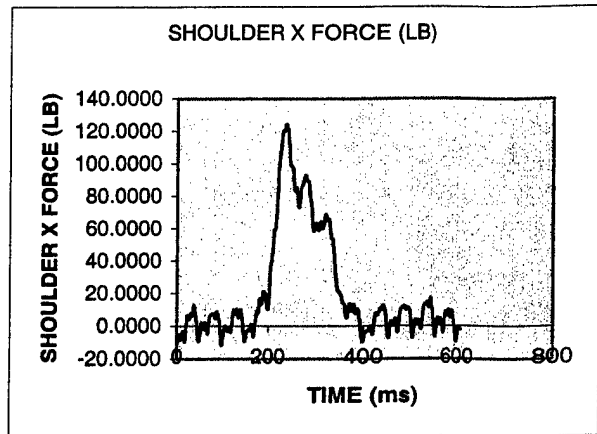
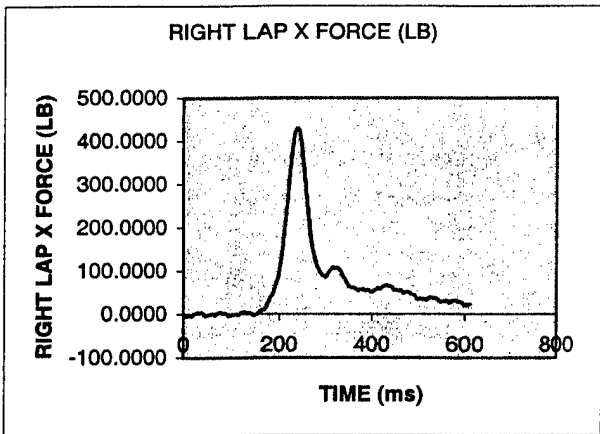
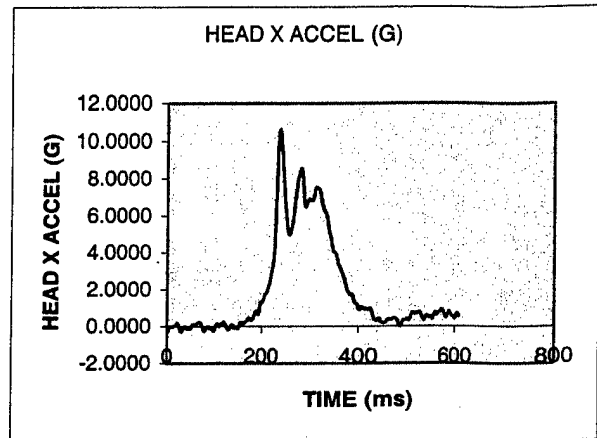
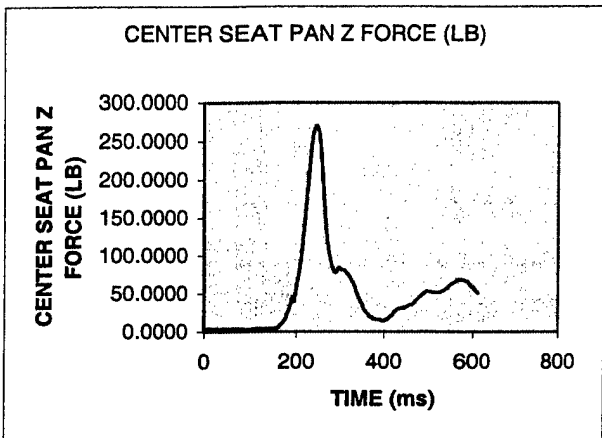
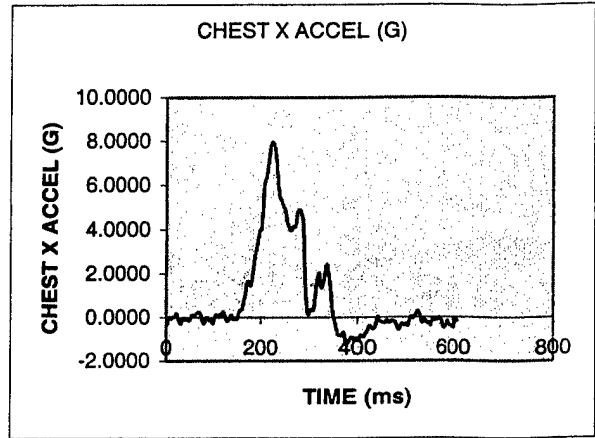
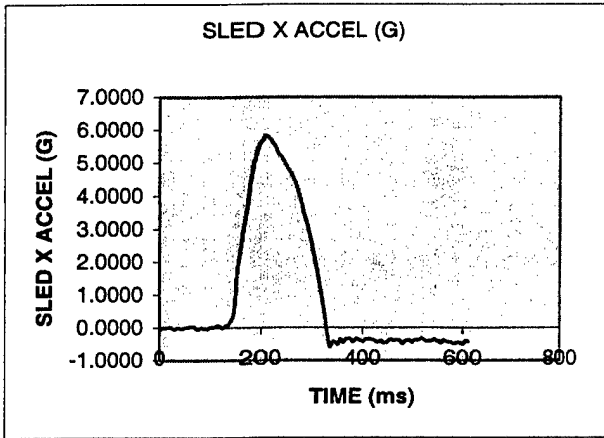

Test Subject HIA 1639 Cell A2

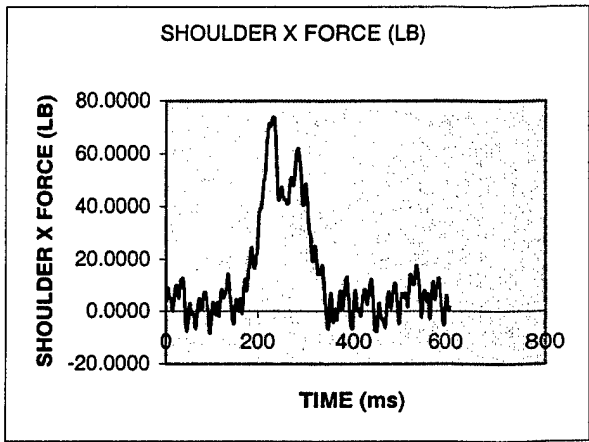
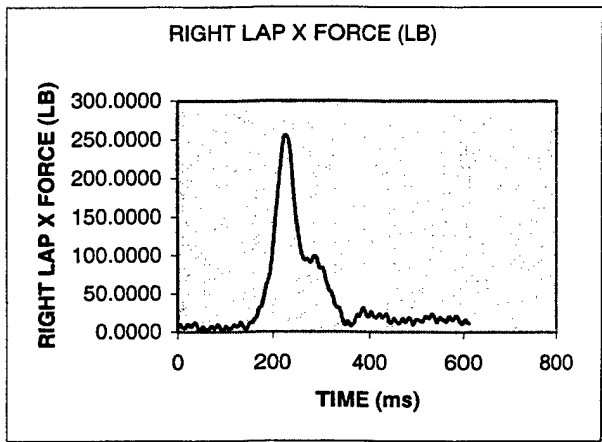
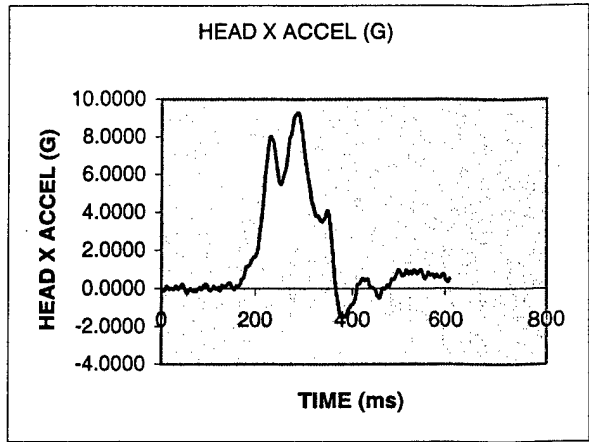
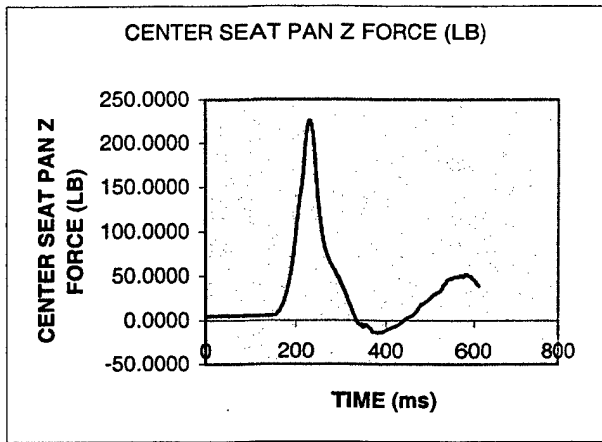
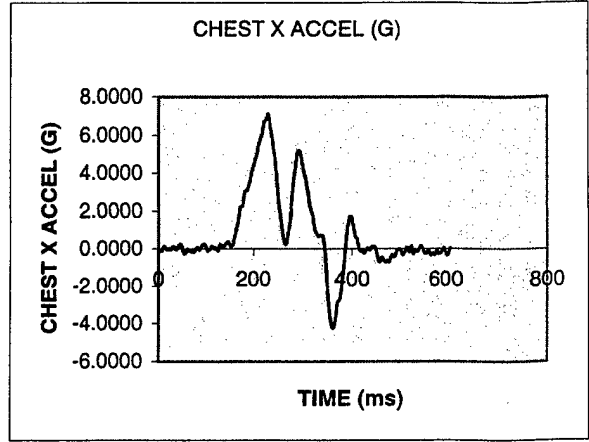
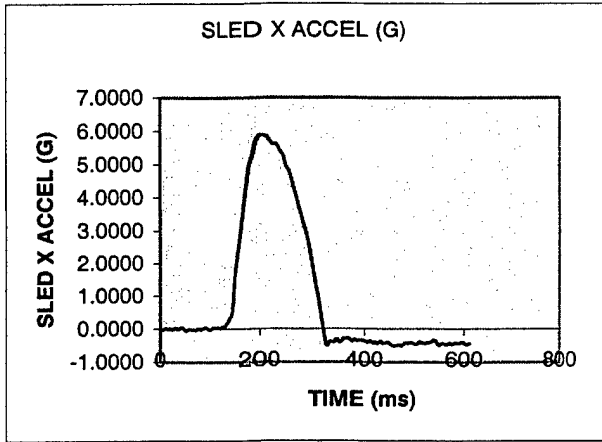

Test Subject HIA 1673 Cell A2

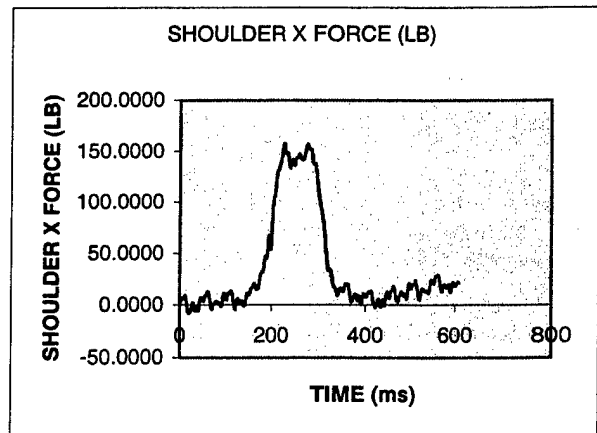
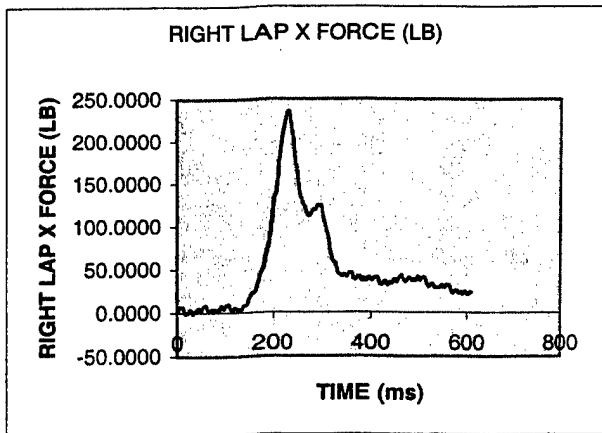
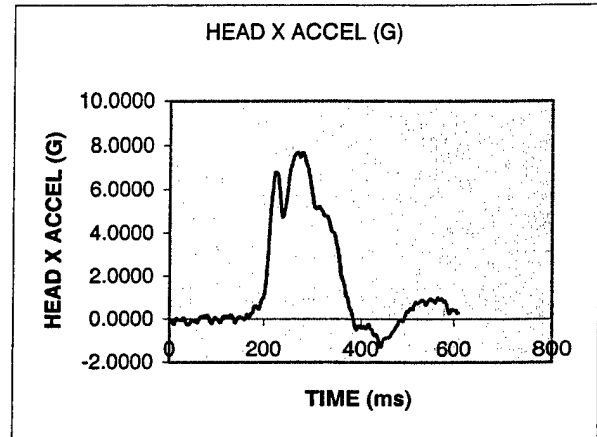
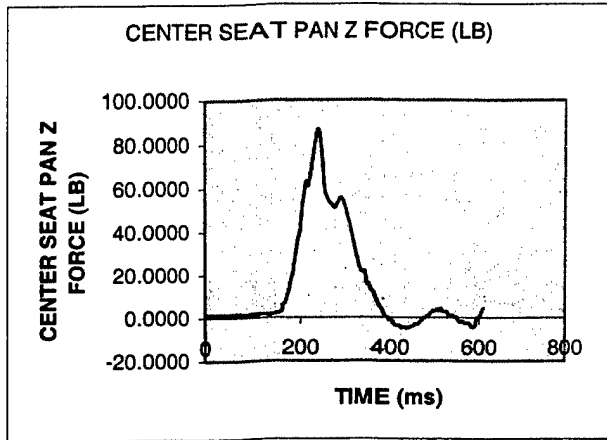
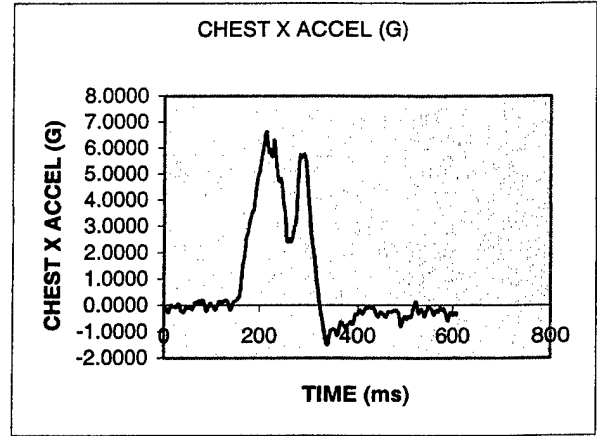
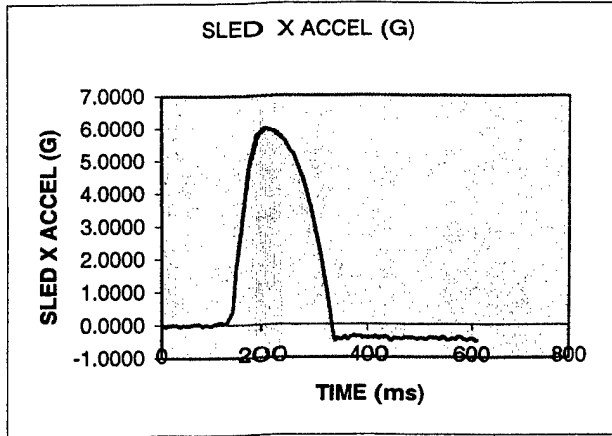

Test Subject HIA1648 Cell A5

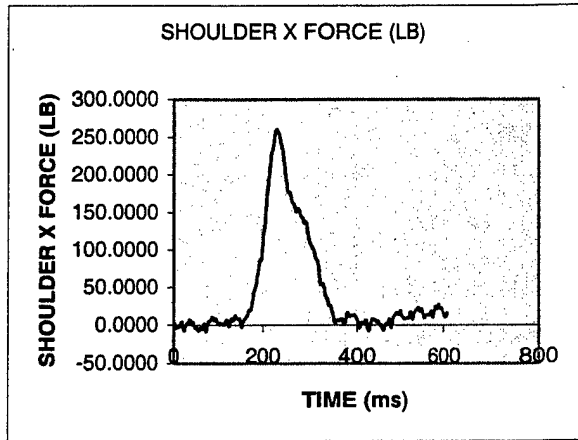
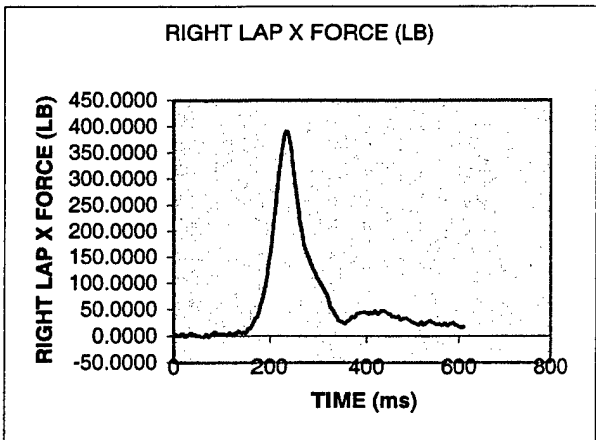
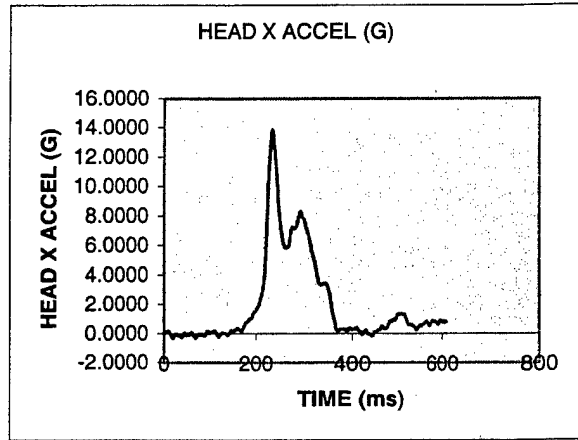
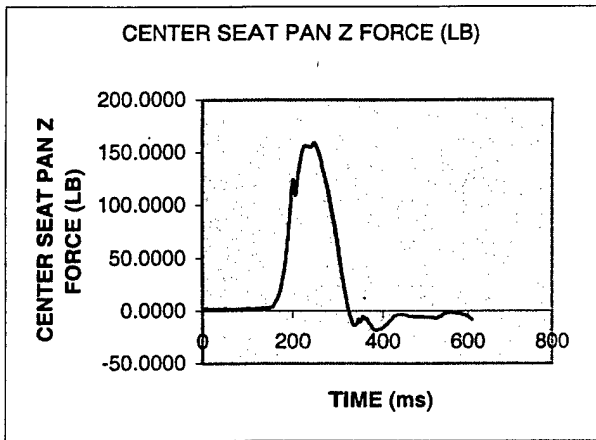
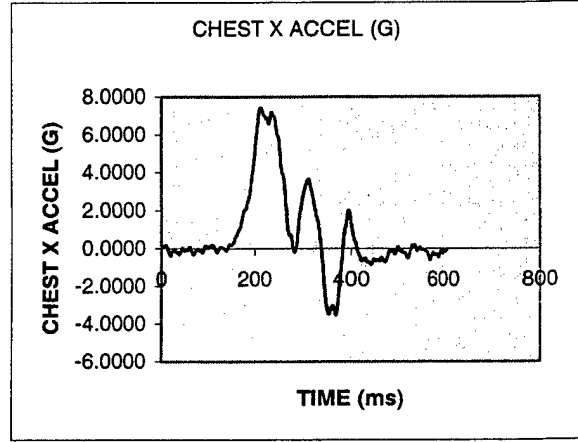
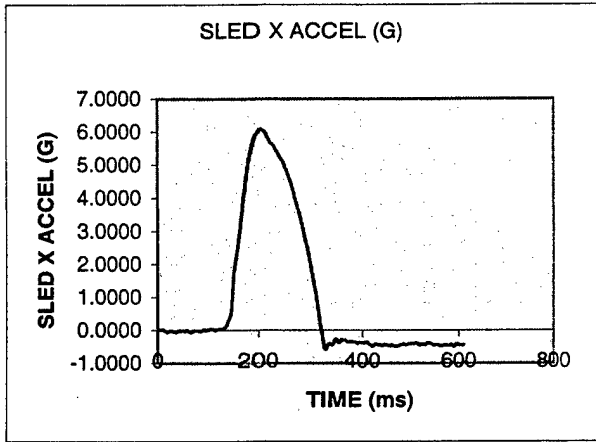

Test Subject HIA 1649 Cell A5

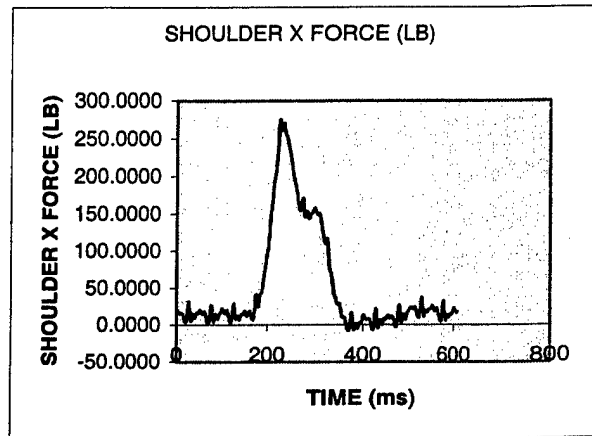
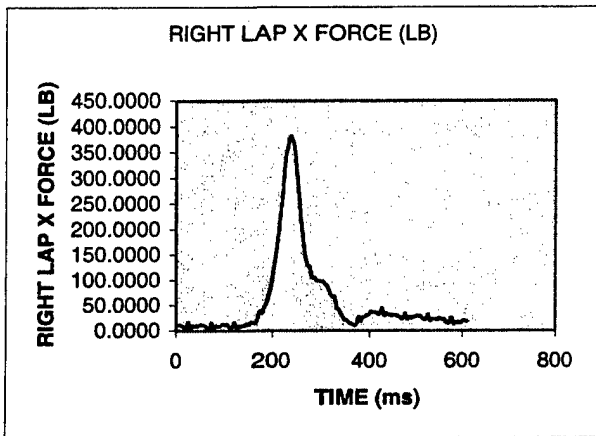
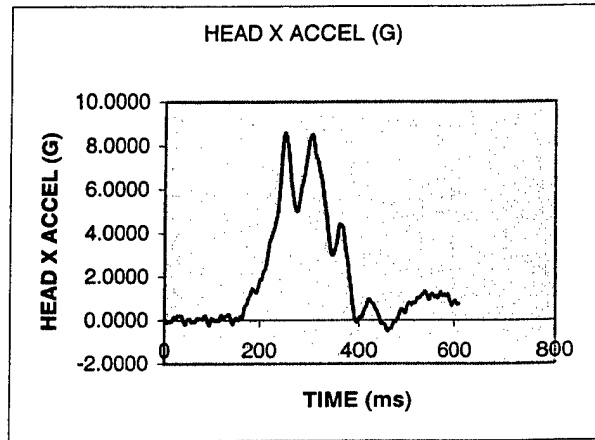
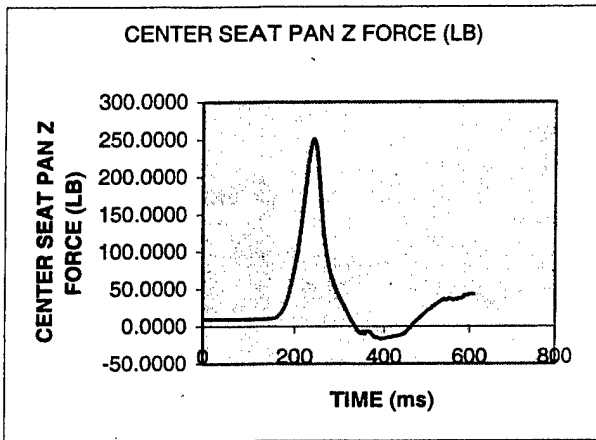
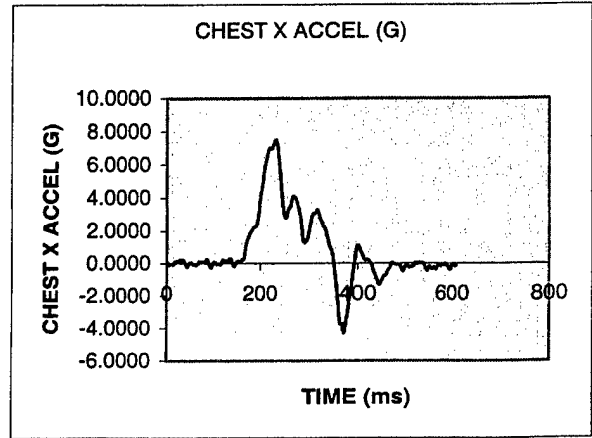
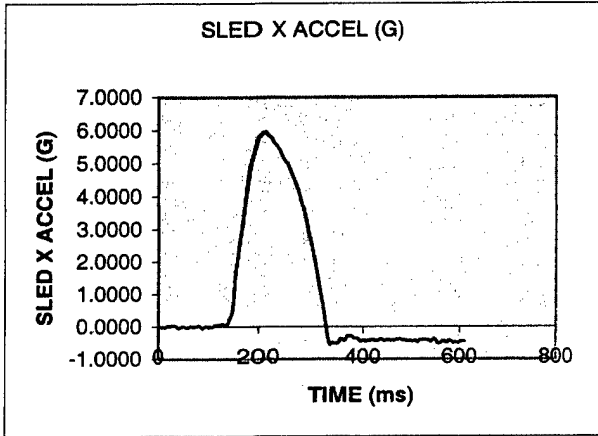

Test Subject HIA 1652 Cell A6

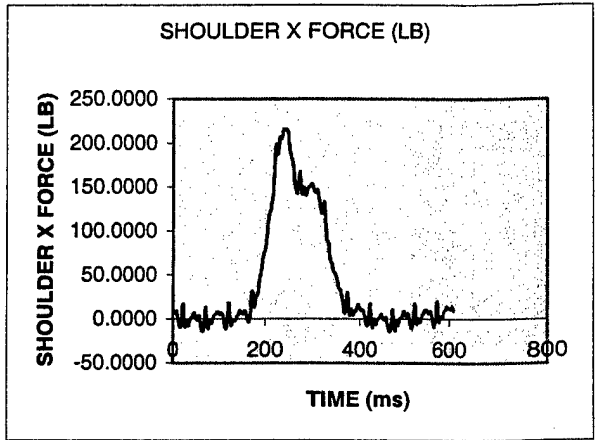
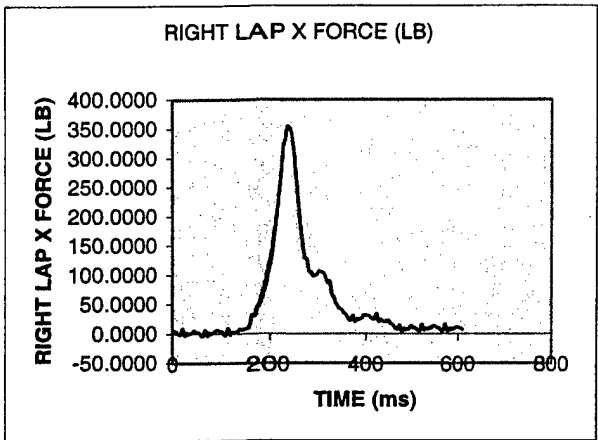
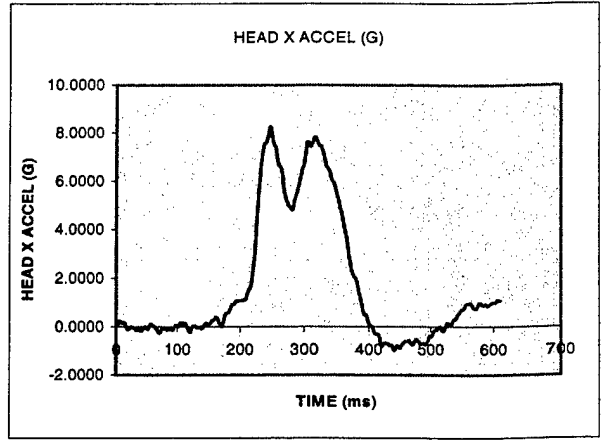
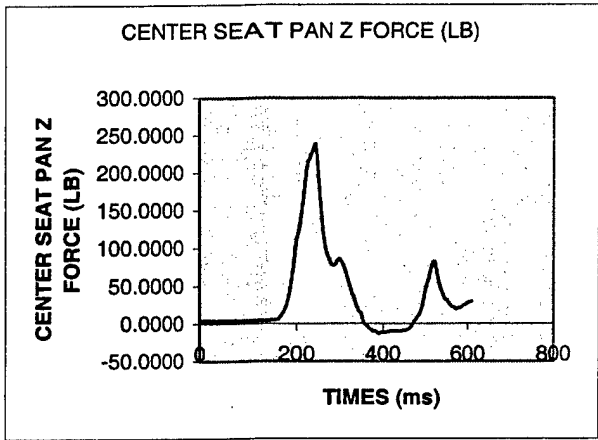
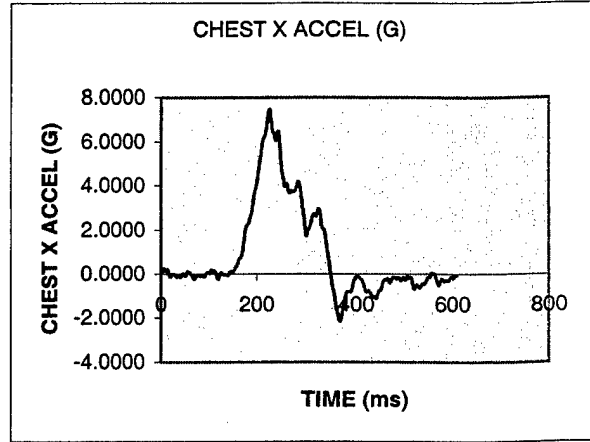
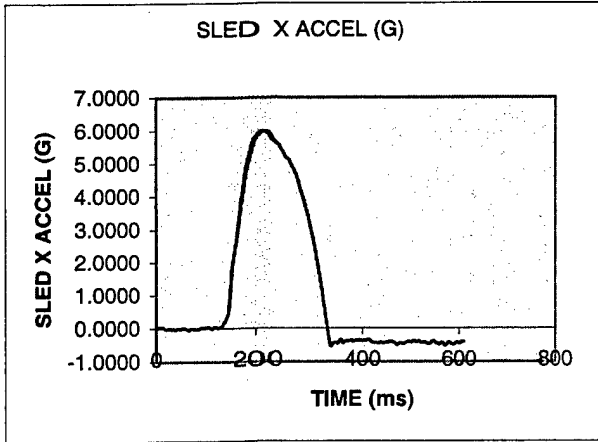

Test Subject HIA 1656 Cell A6

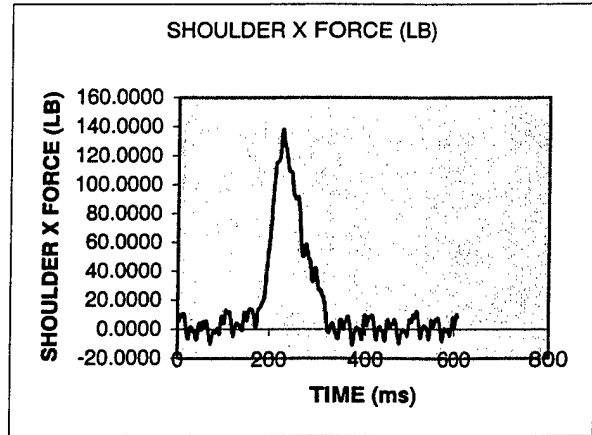
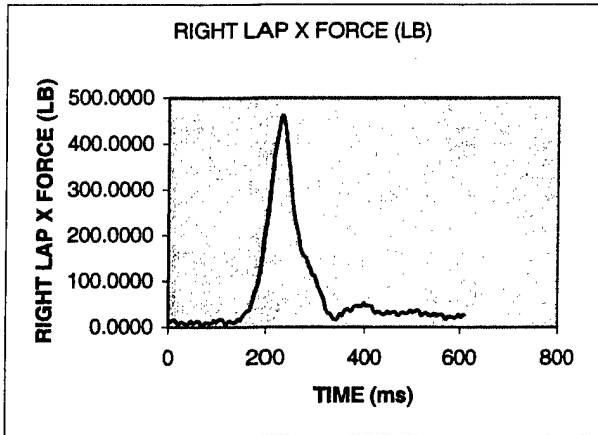
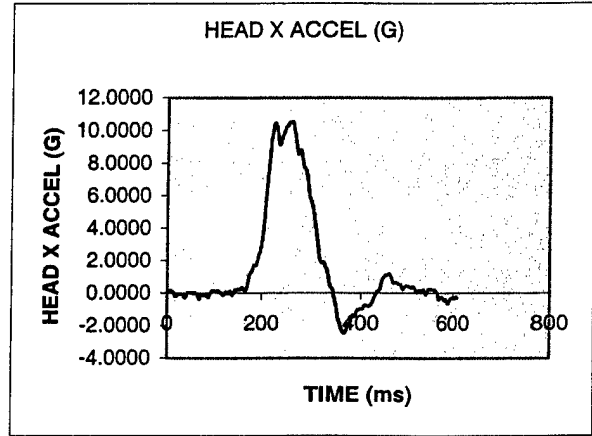
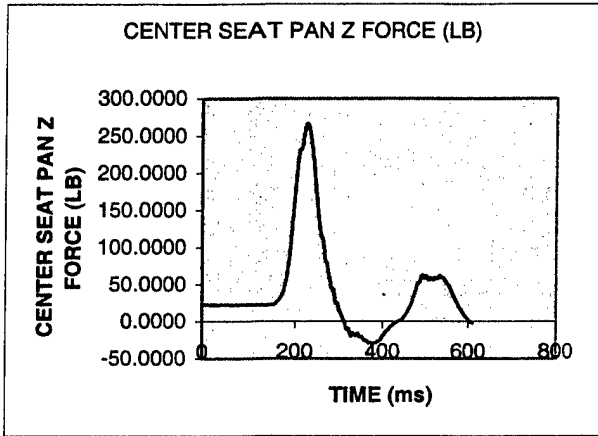
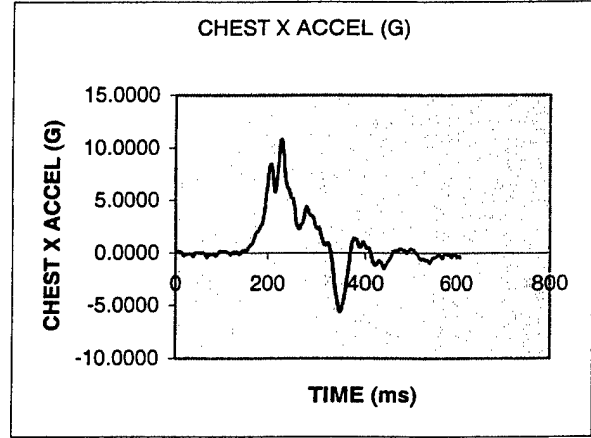
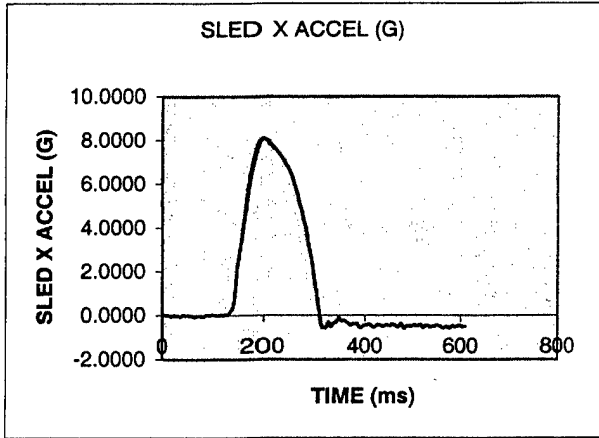

Test Subject HIA 1601 Cell B1

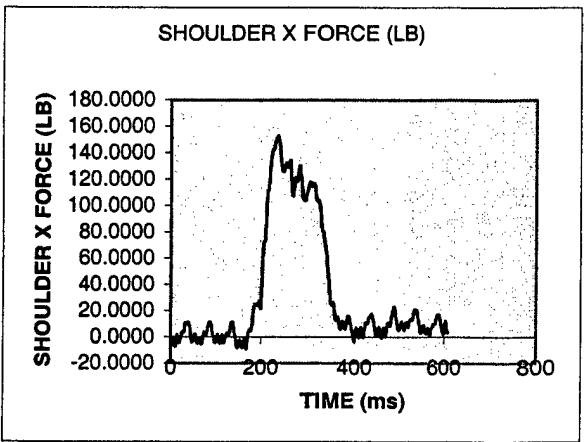
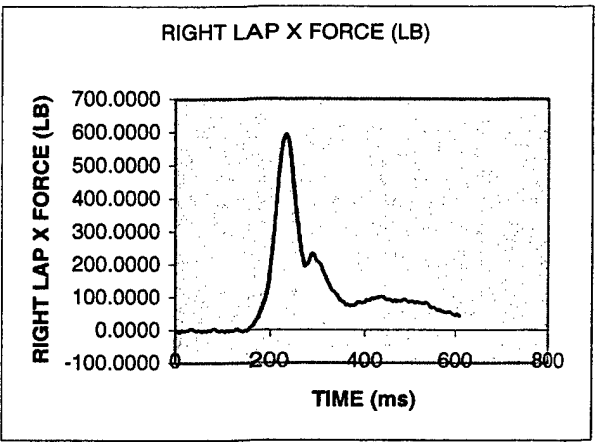
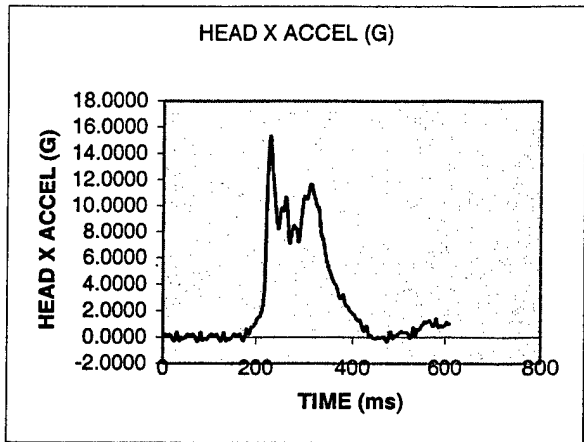
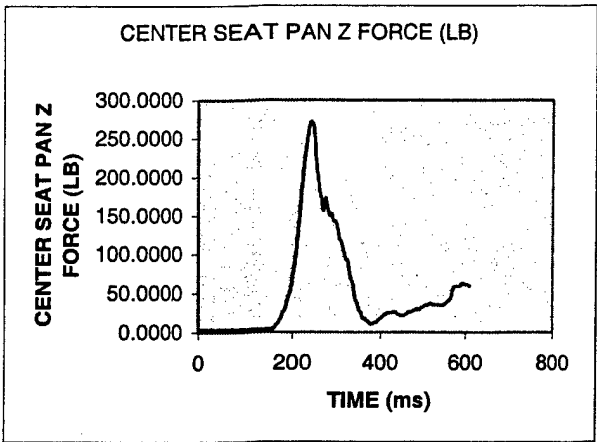
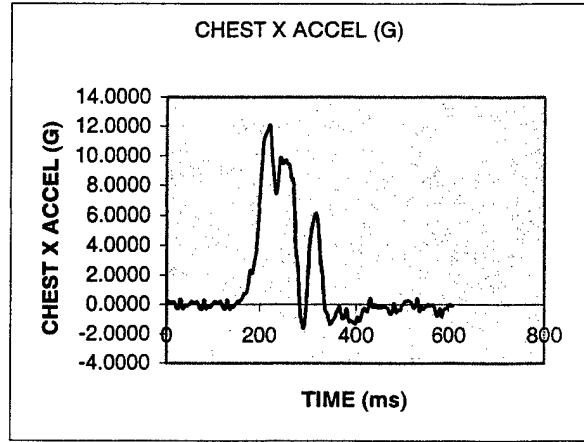
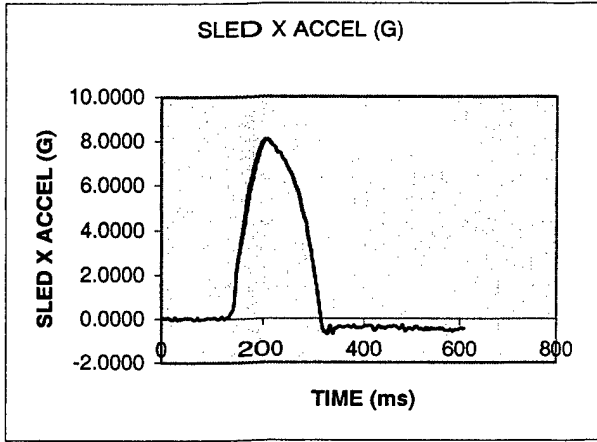

Test Subject HIA 1662 Cell B1

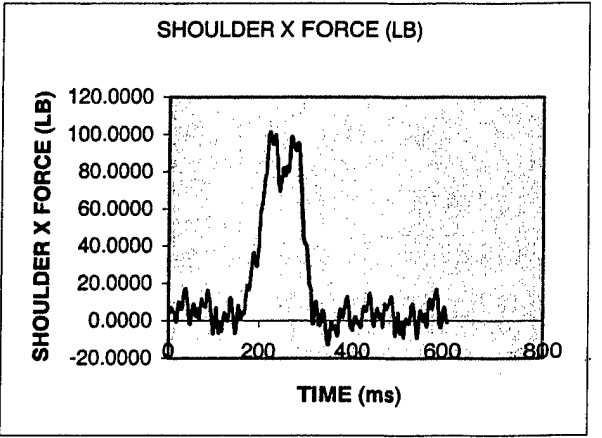
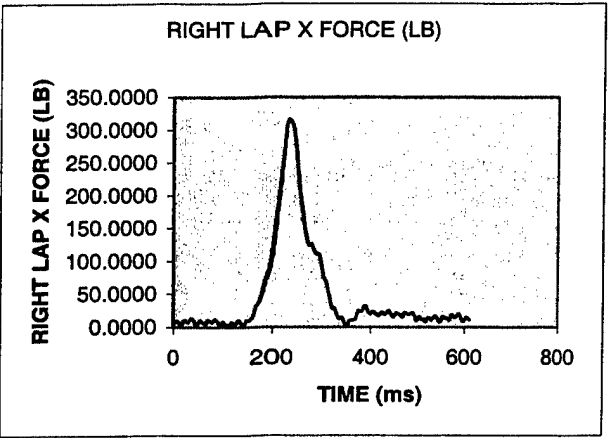
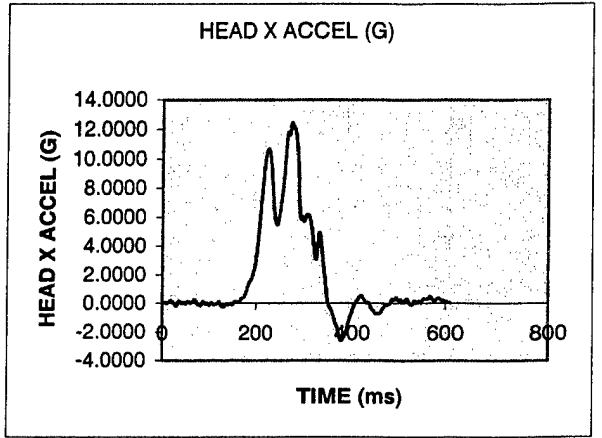
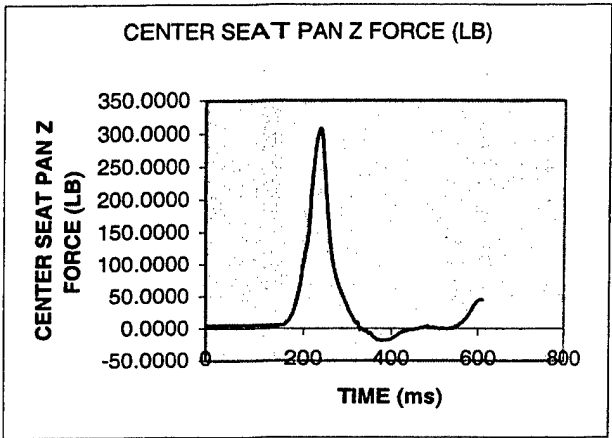
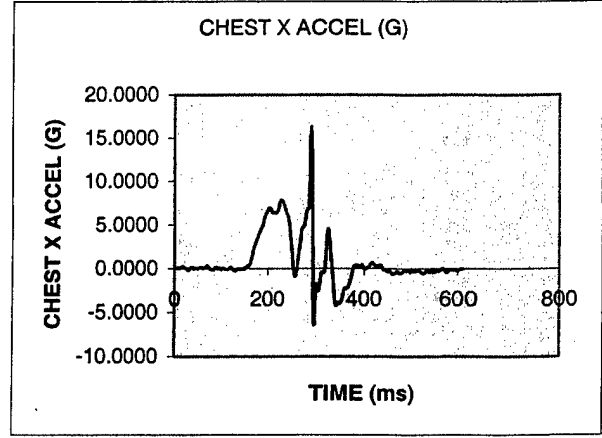
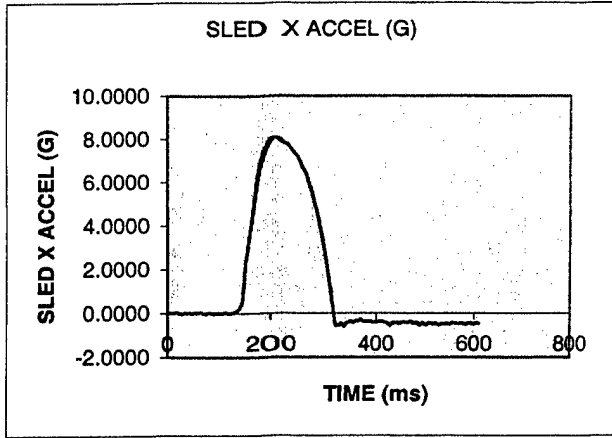

Test Subject HIA 1681 Cell B2

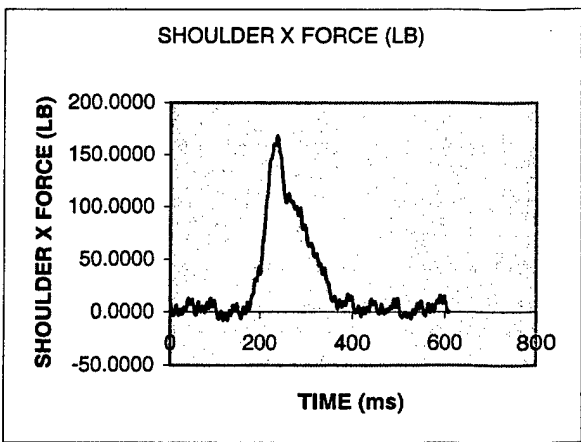
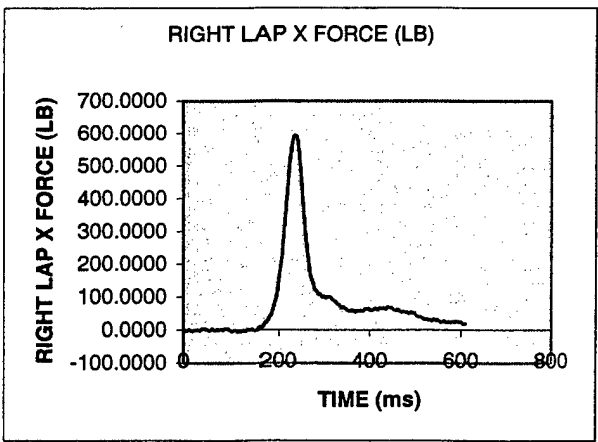
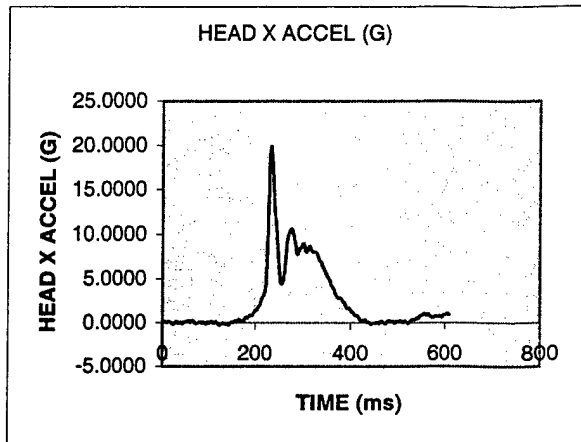
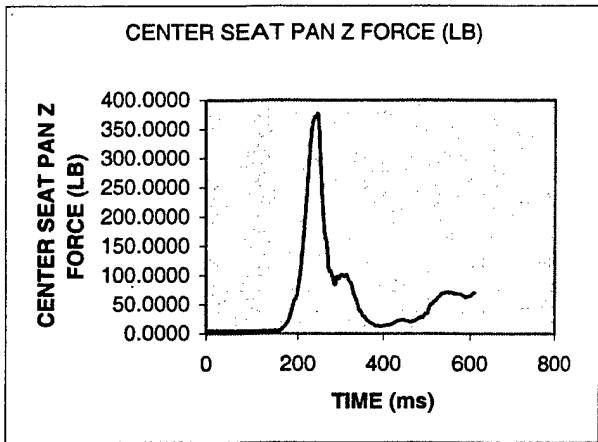
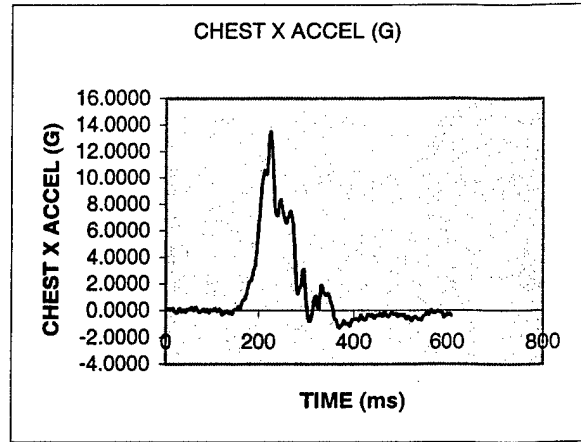
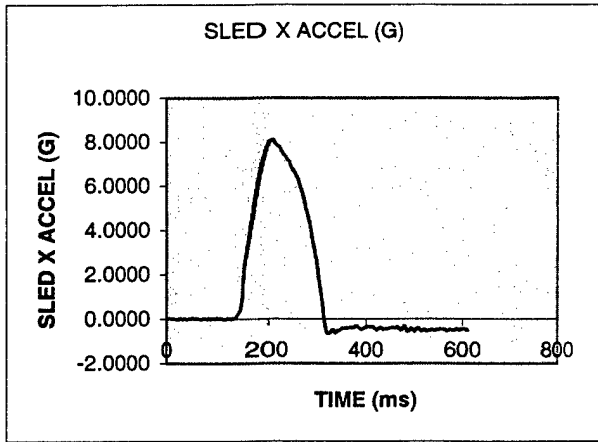

Test Subject HIA 1695 Cell B2

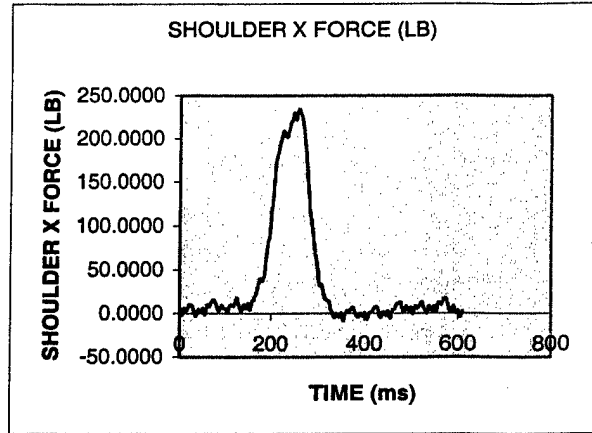
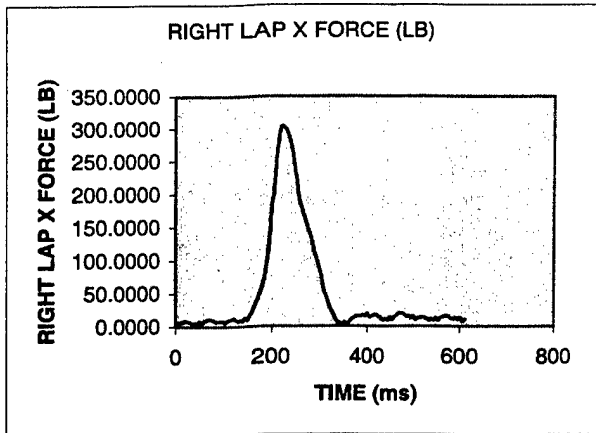
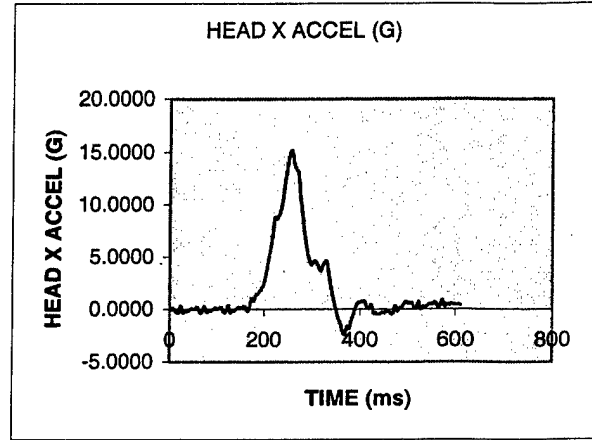
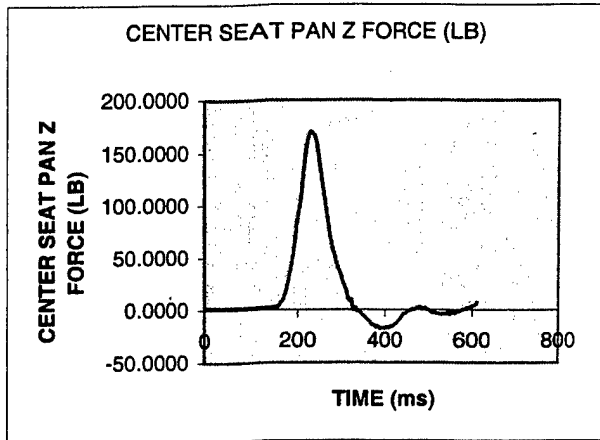
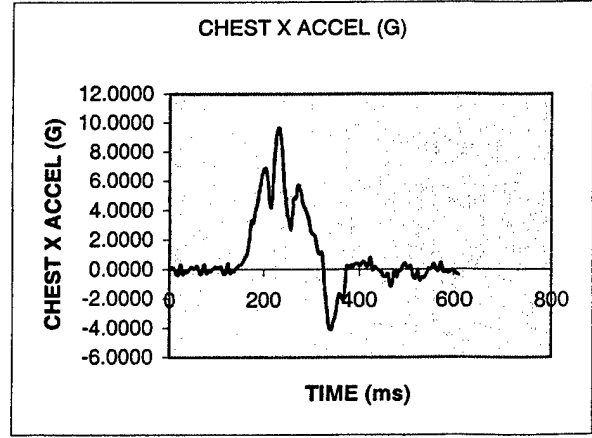
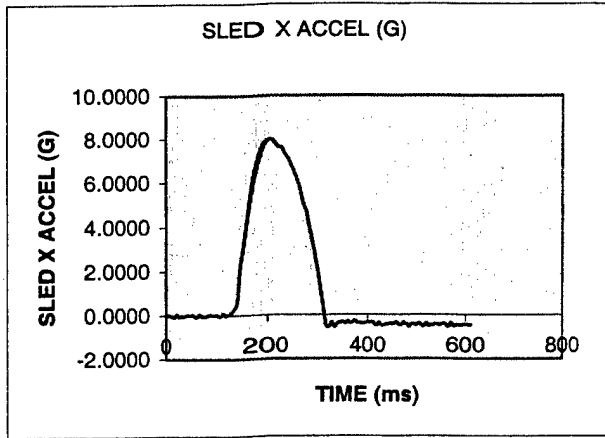

Test Subject HIA 1663 Cell B5

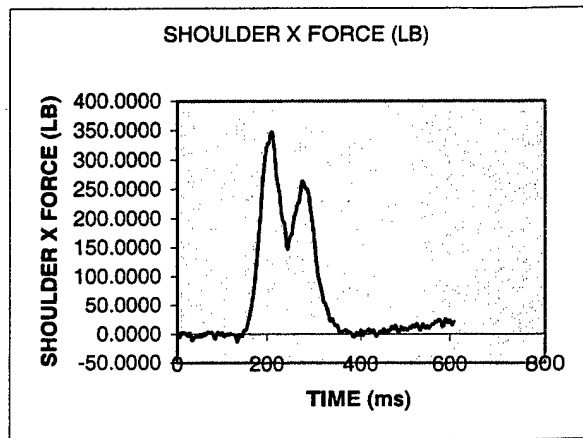
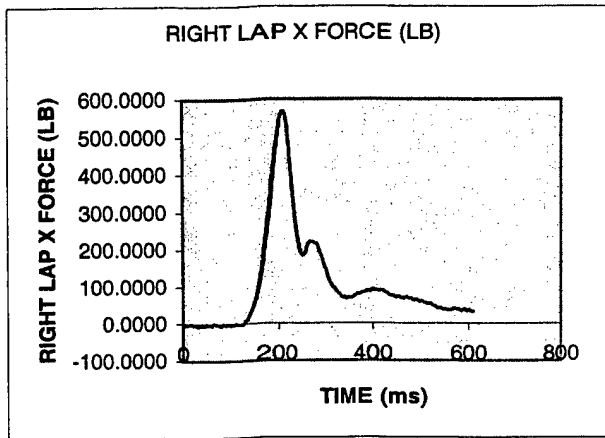
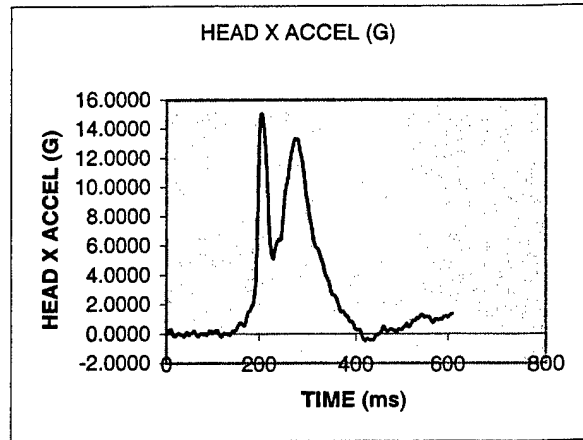
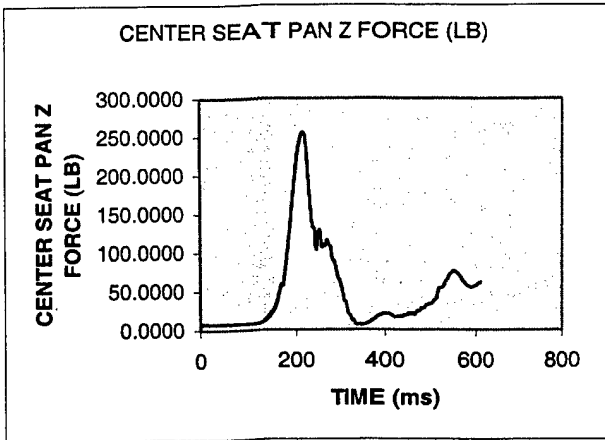
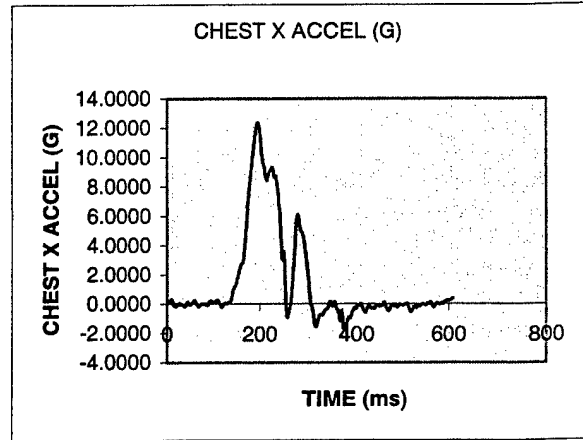
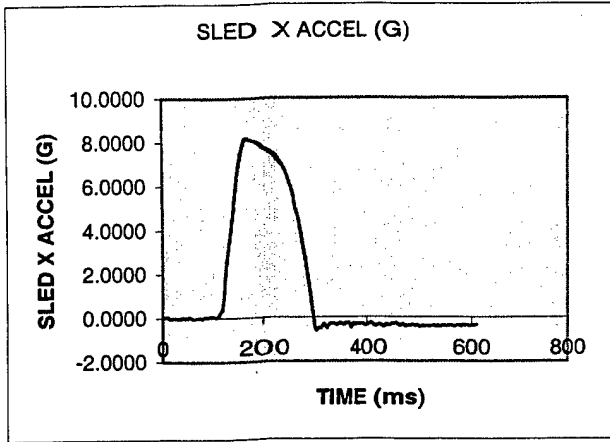

Test Subject HIA 1753 Cell B5

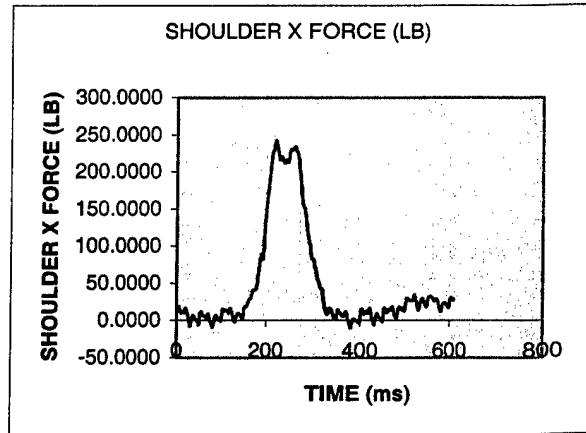
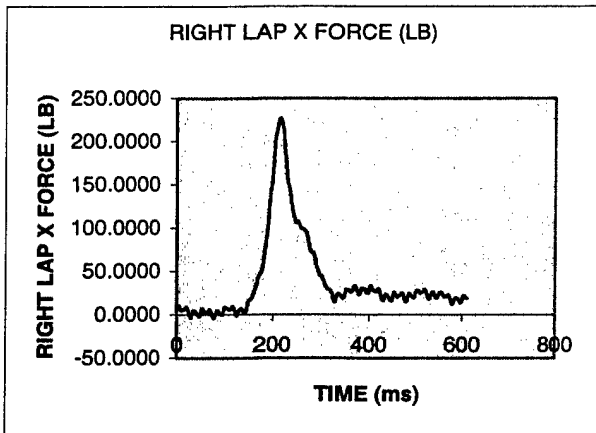
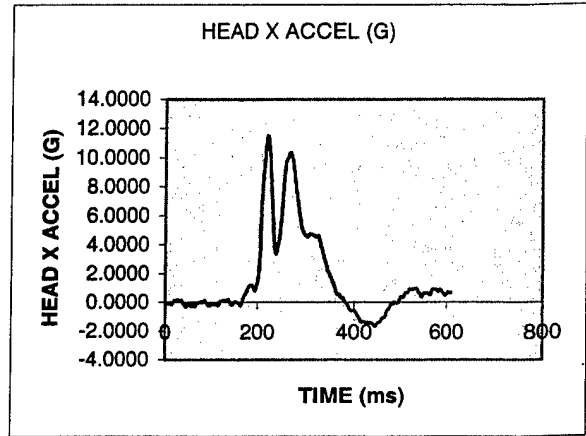
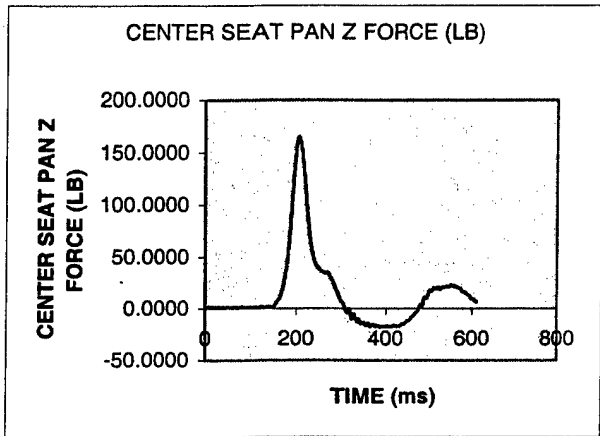
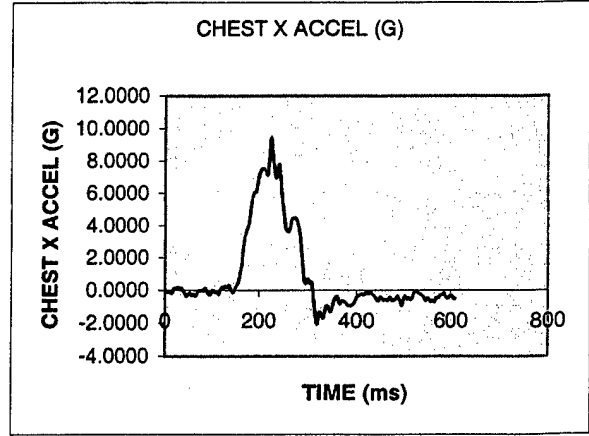
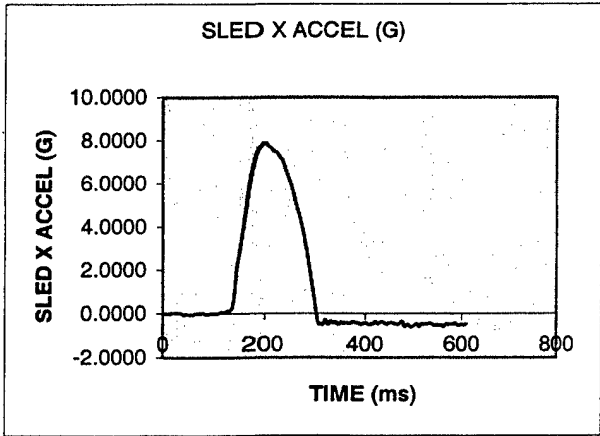

Test Subject HIA 1593 Cell B6

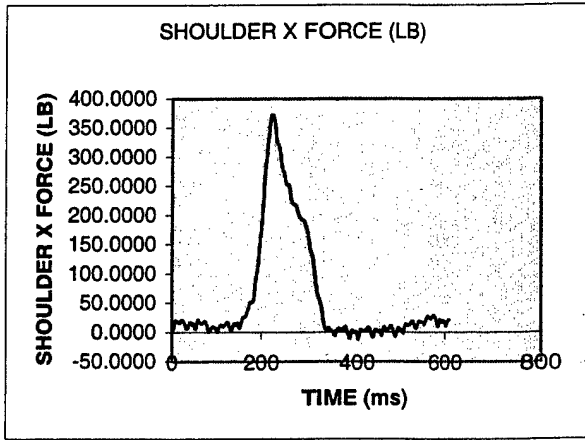
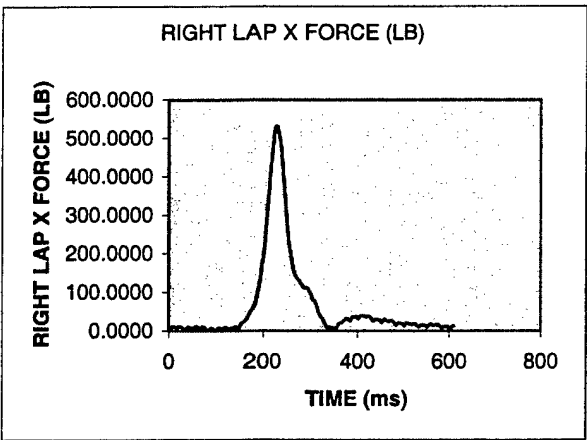
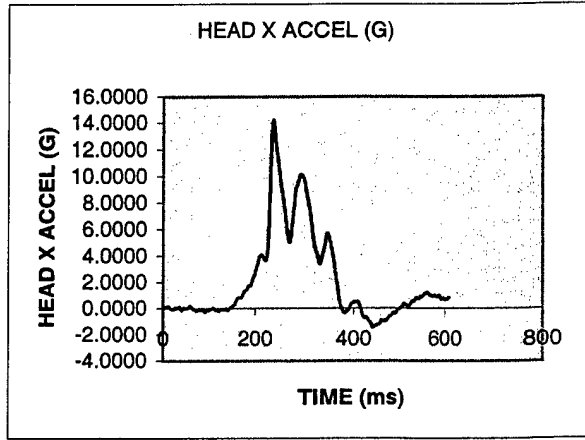
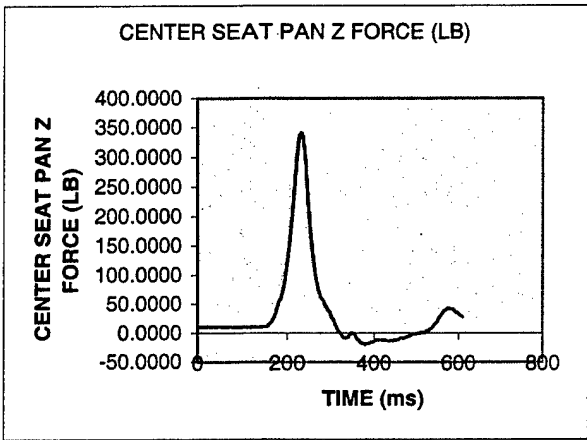
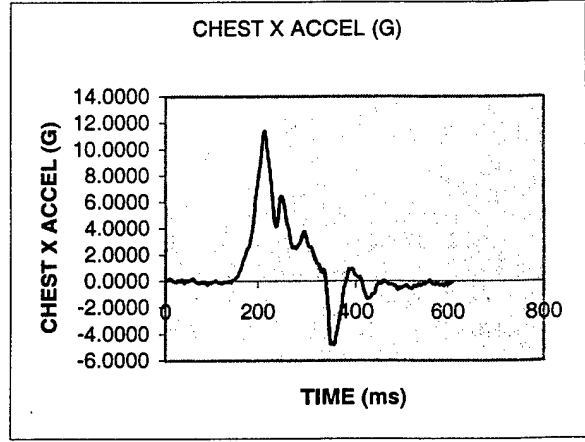
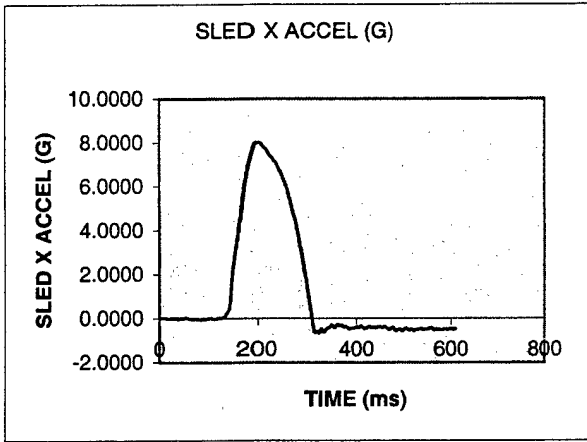

Test Subject HIA 1679 Cell B6

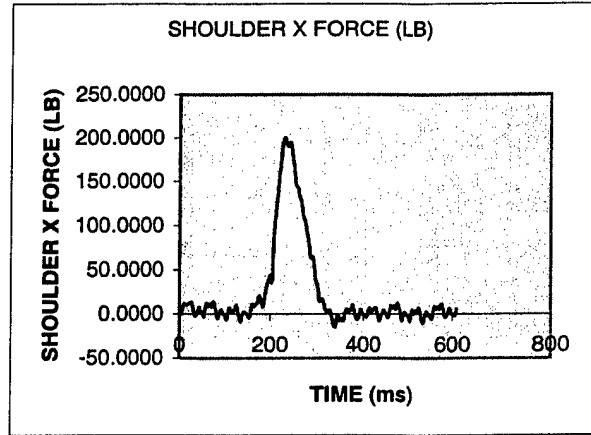
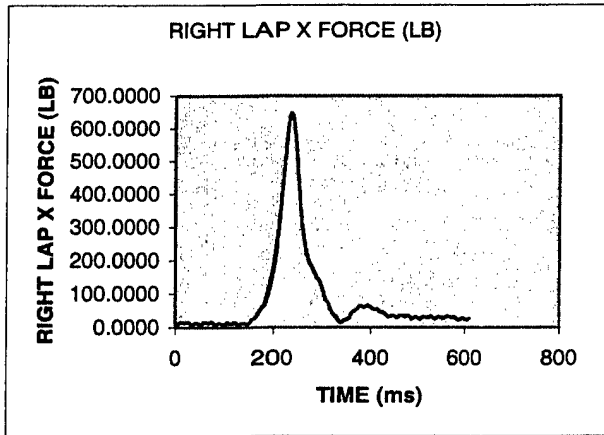
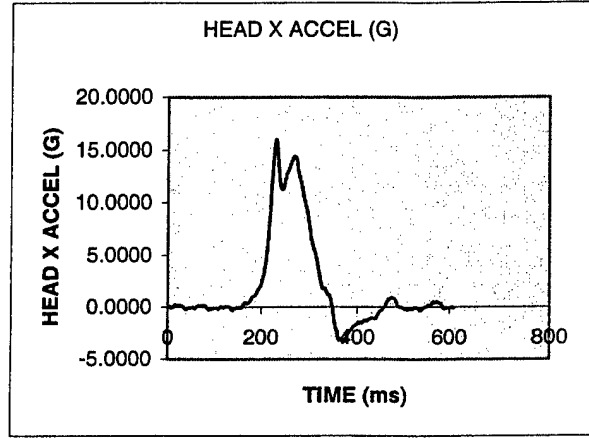
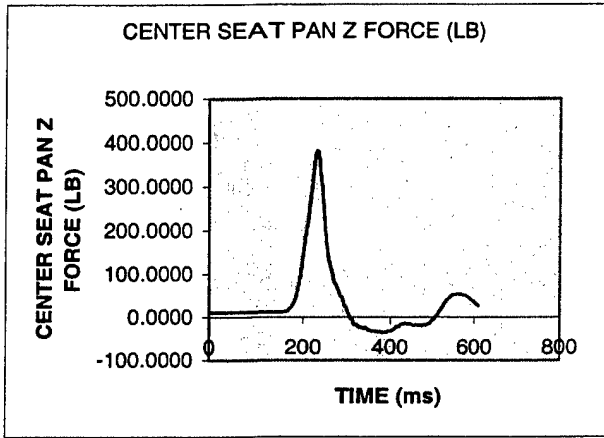
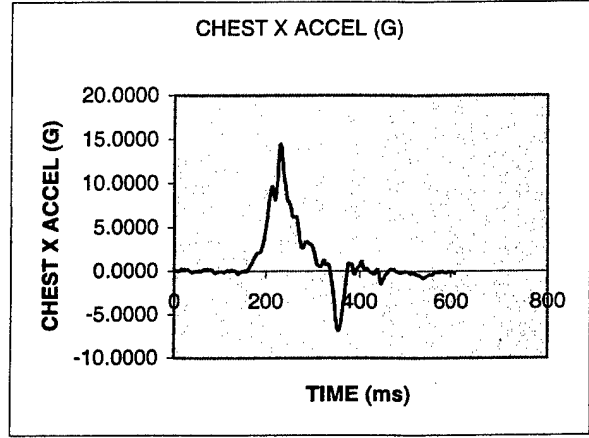
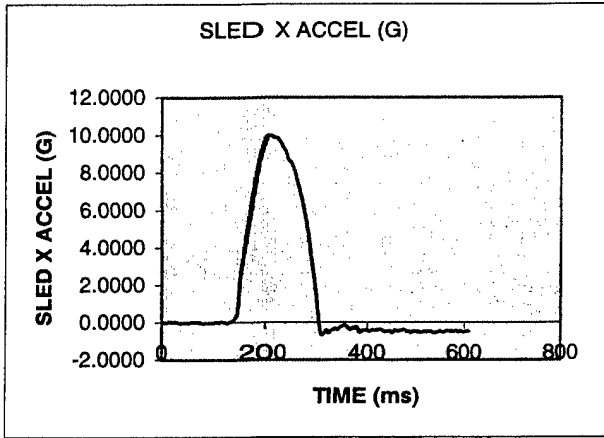

Test Subject HIA 1623 Cell C1

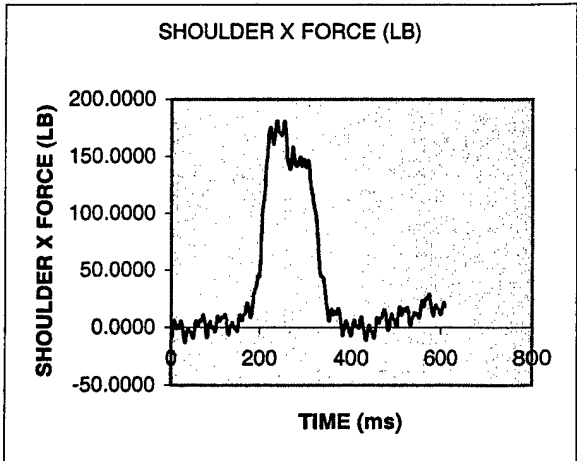
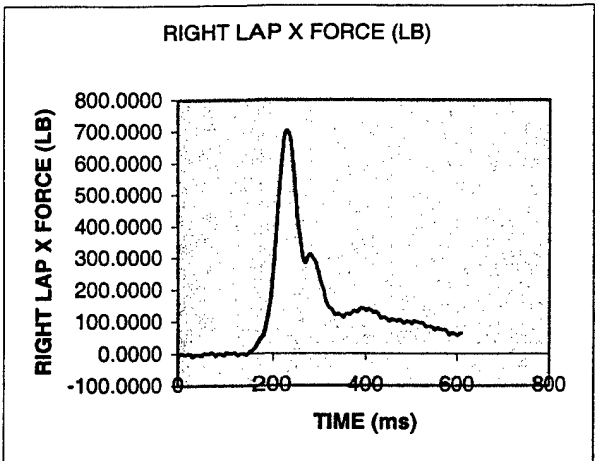
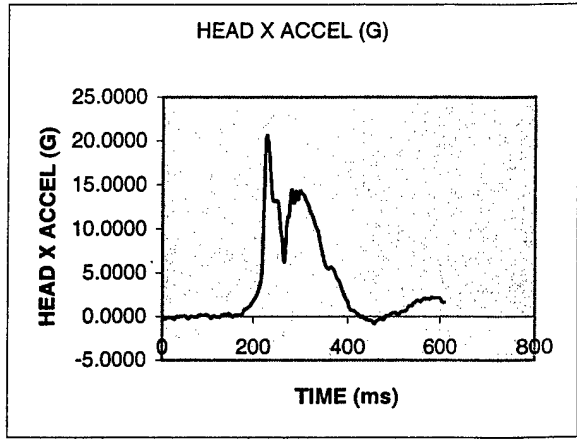
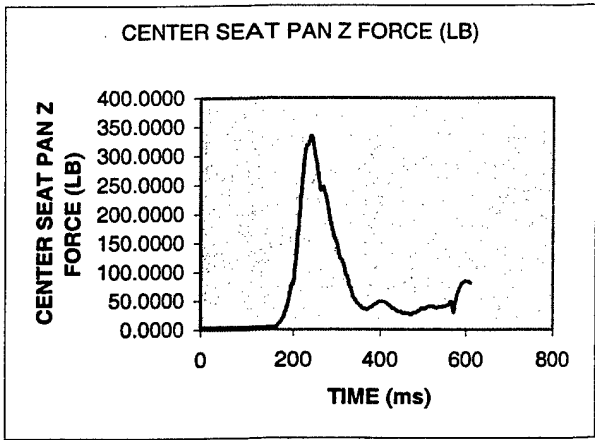
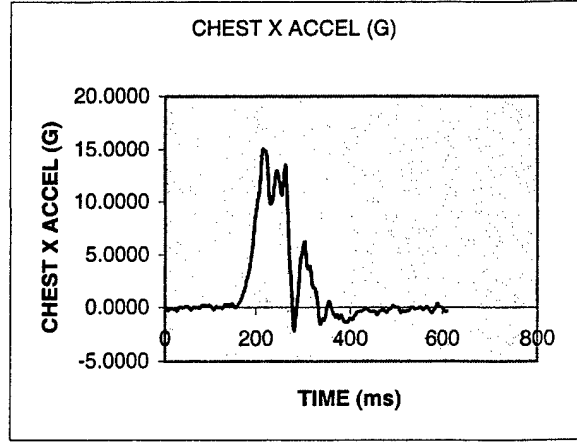
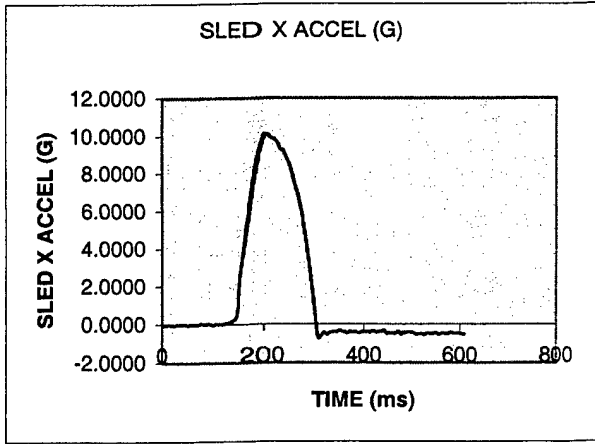

Test Subject HIA 1632 Cell C1

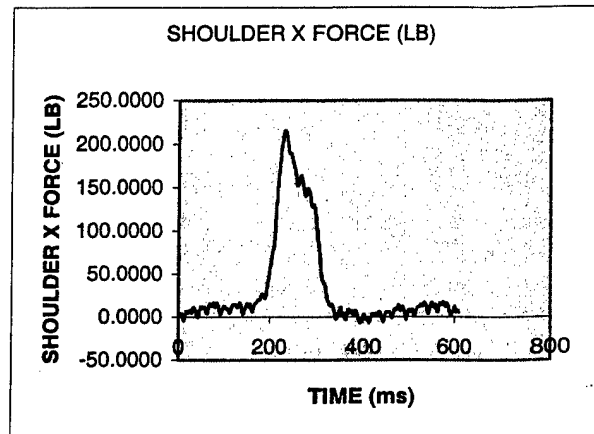
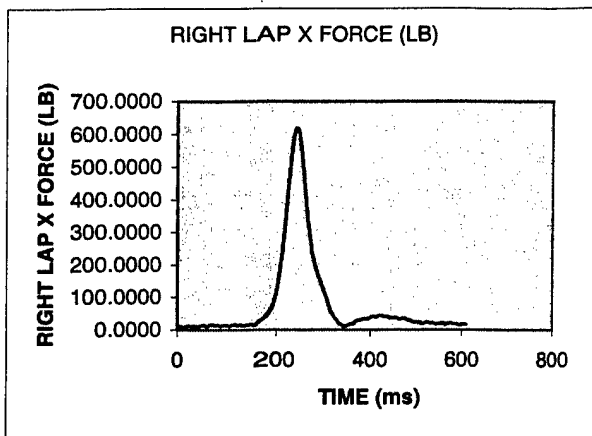
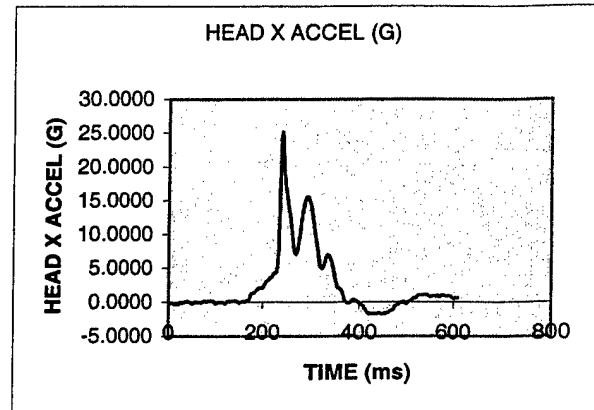
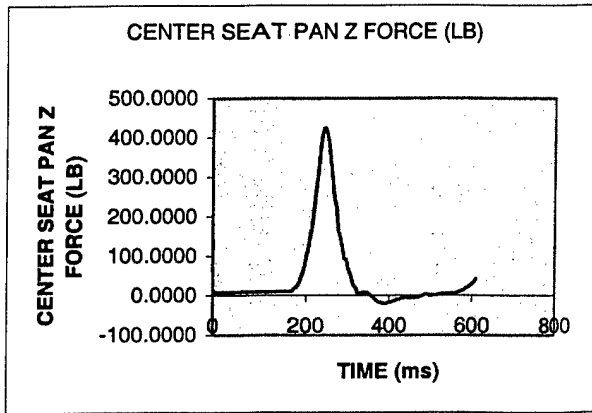
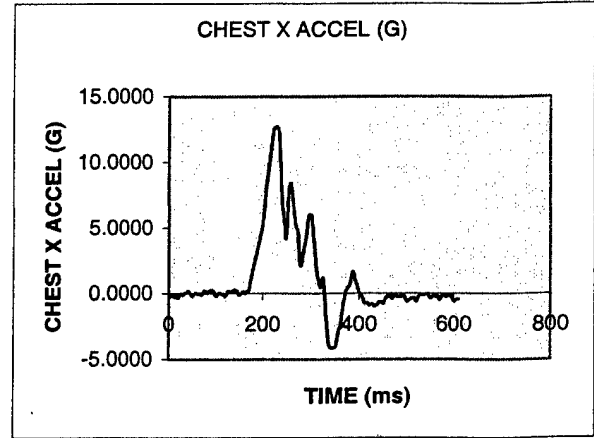
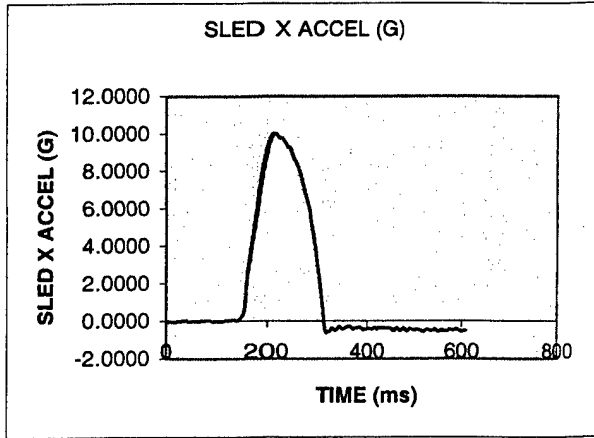

Test Subject HIA 1627 Cell C2

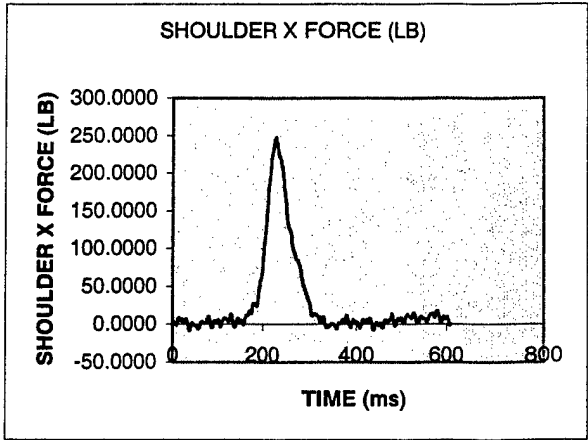
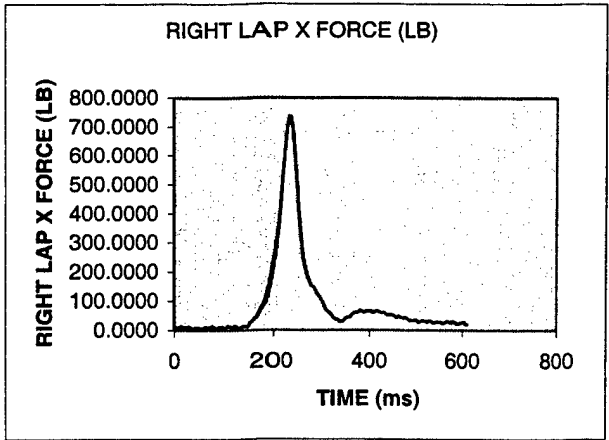
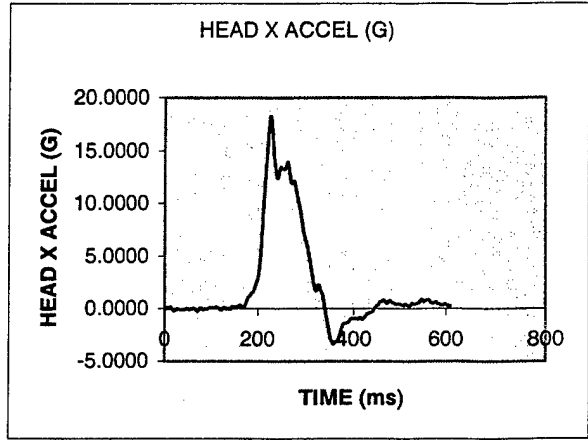
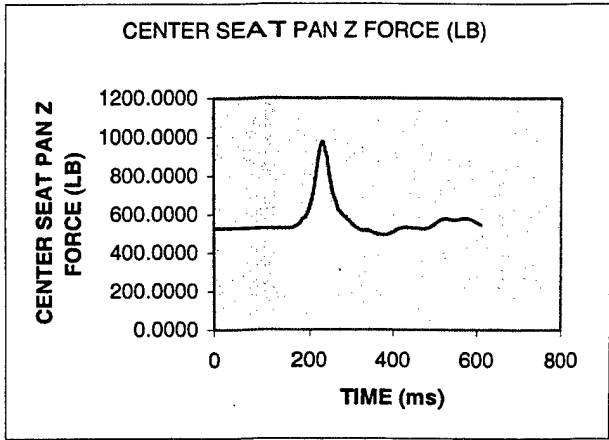
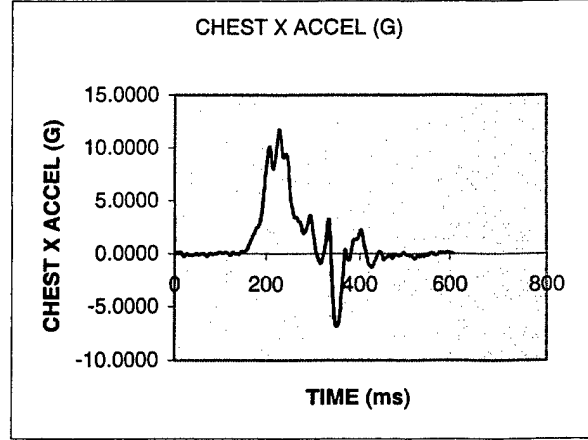
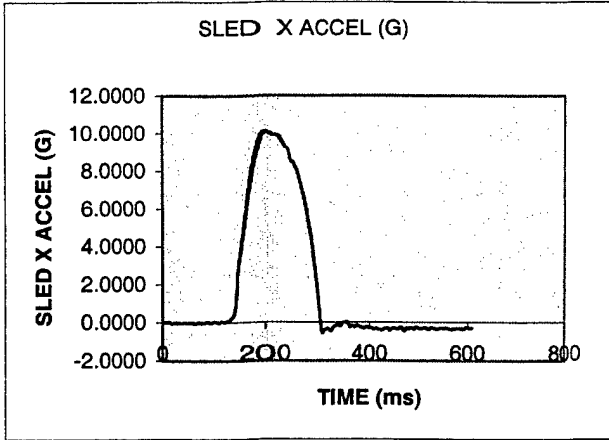

Test Subject HIA 1720 Cell C2

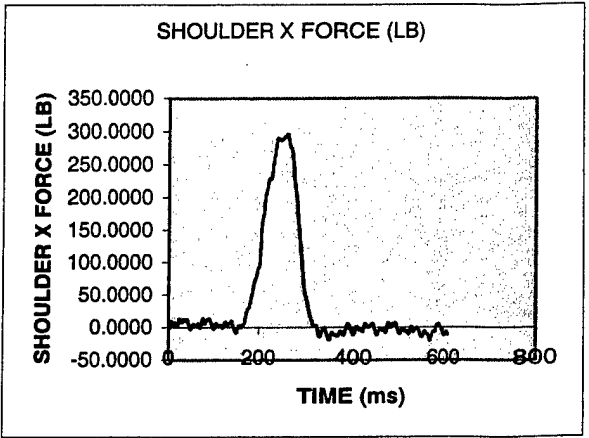
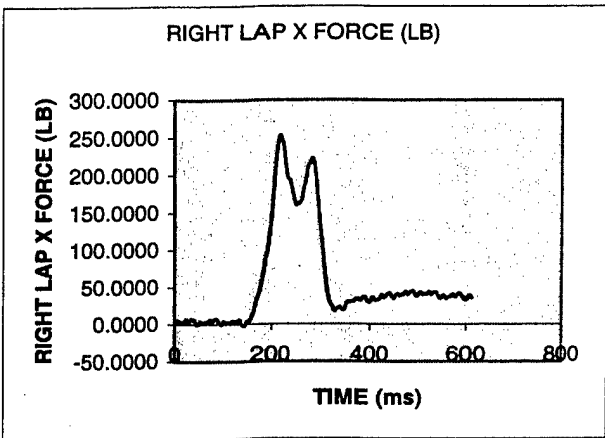
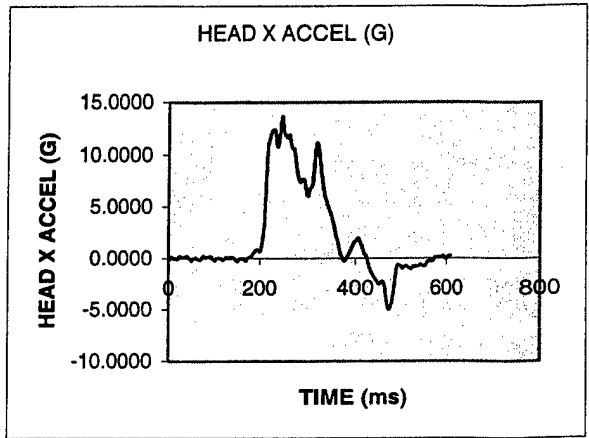
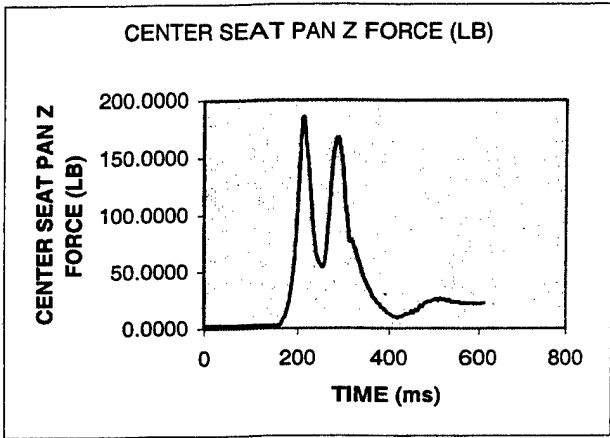
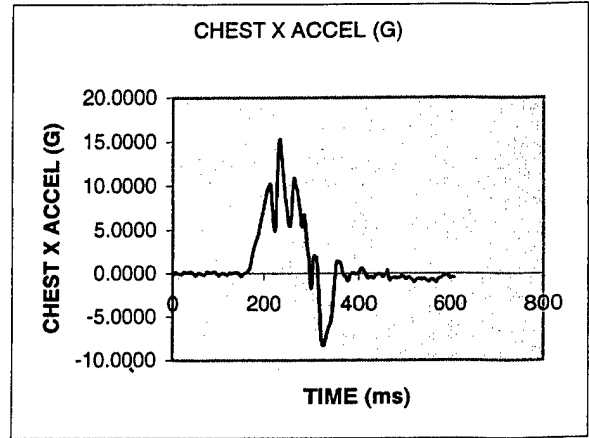
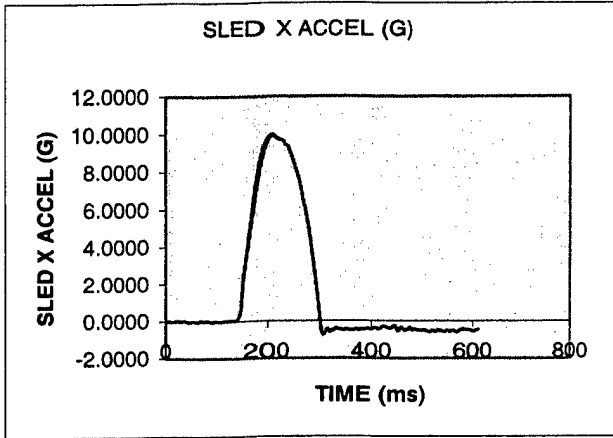

Test Subject HIA 1611 Cell C5

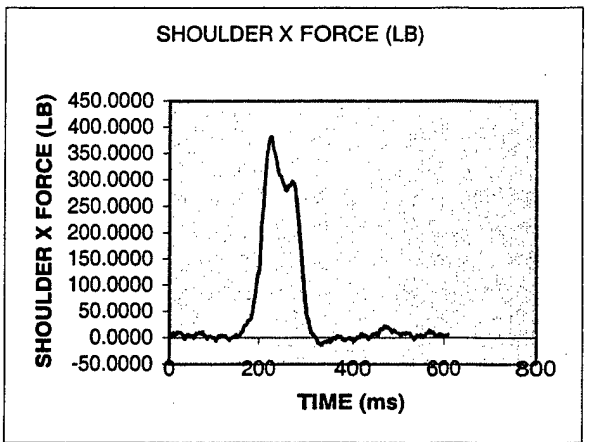
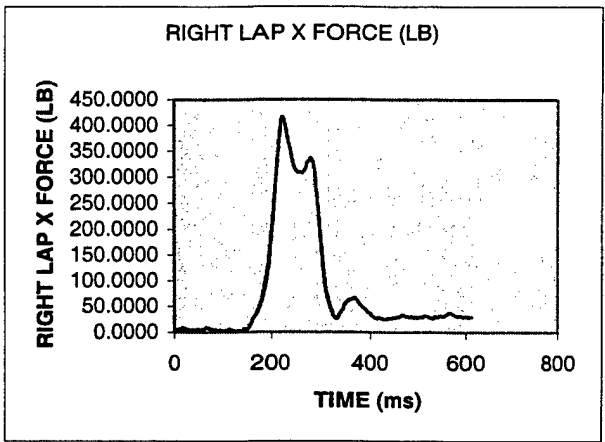
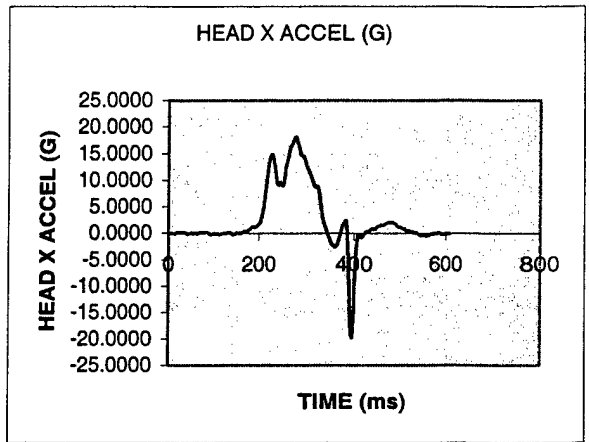
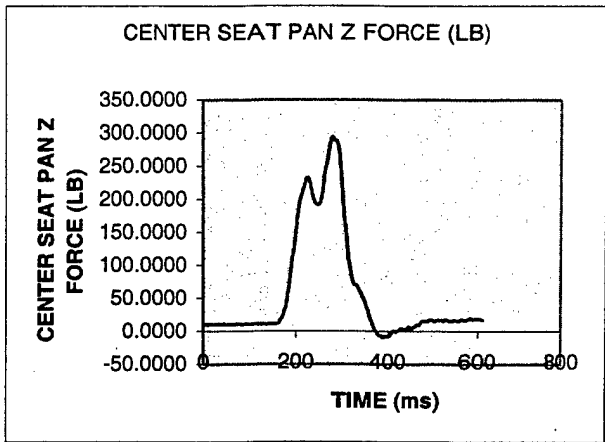
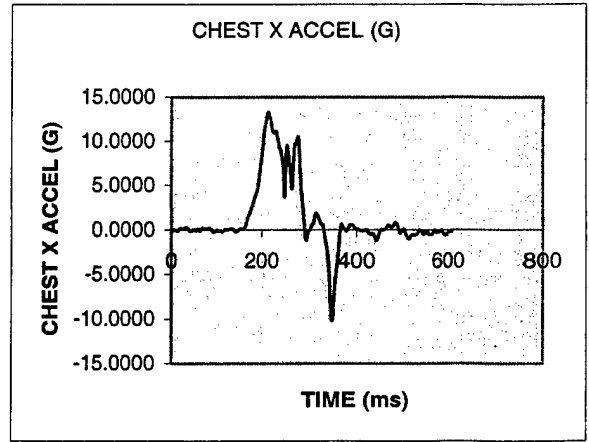
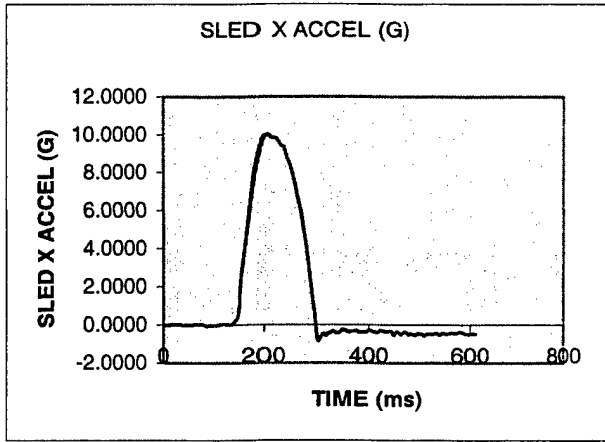

Test Subject HIA 1628 Cell C5

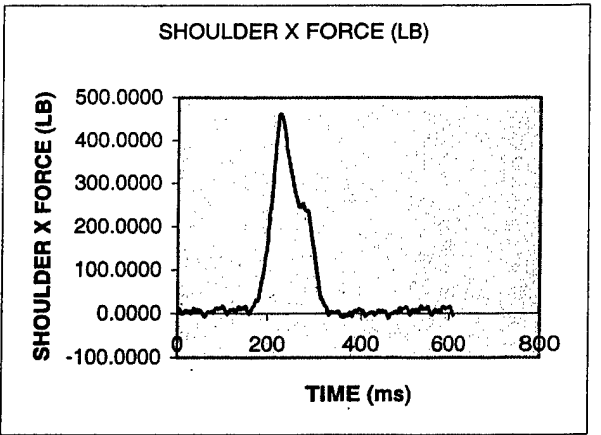
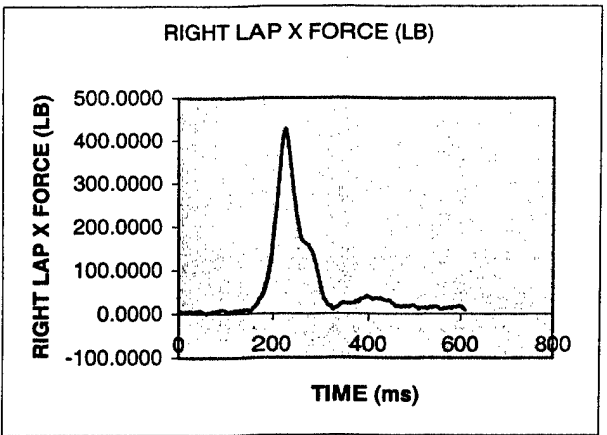
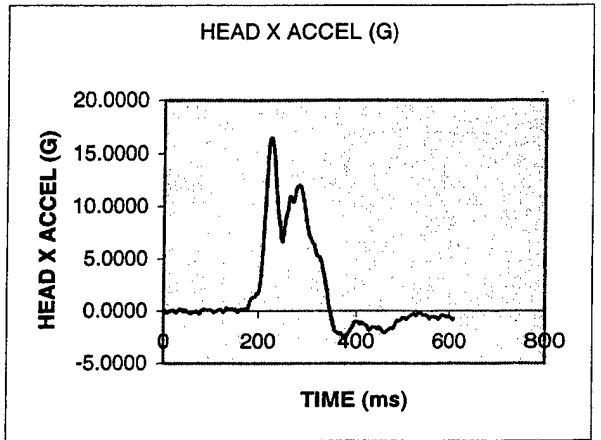
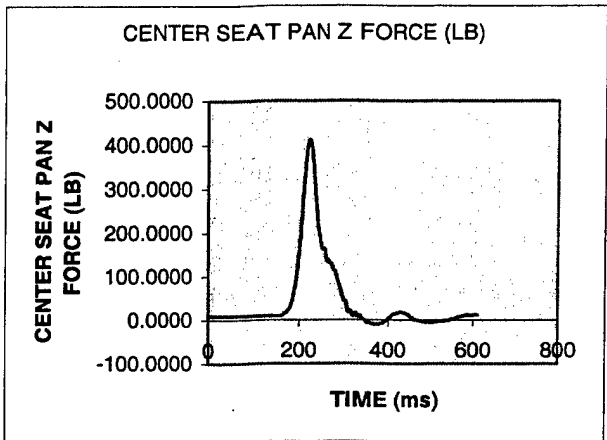
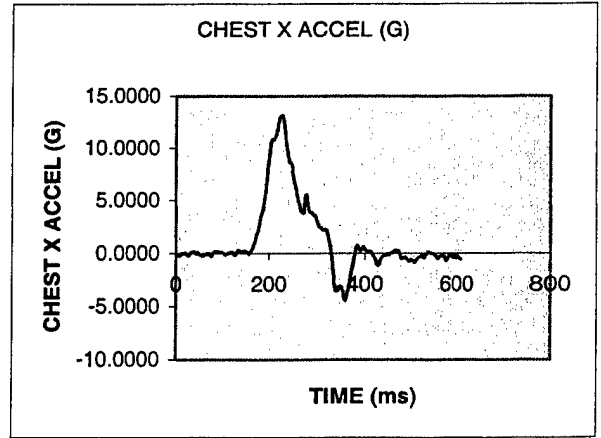
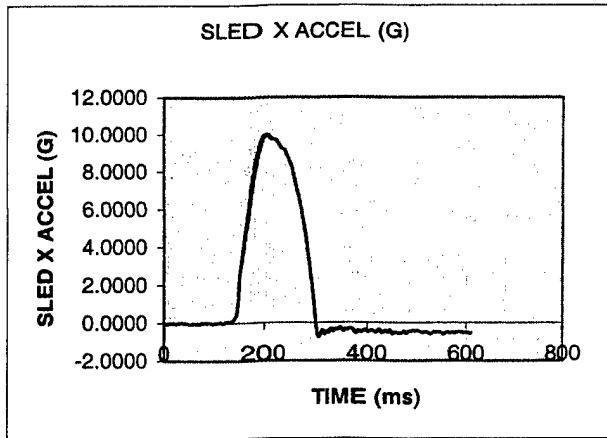

Test Subject HIA 1609 Cell C6

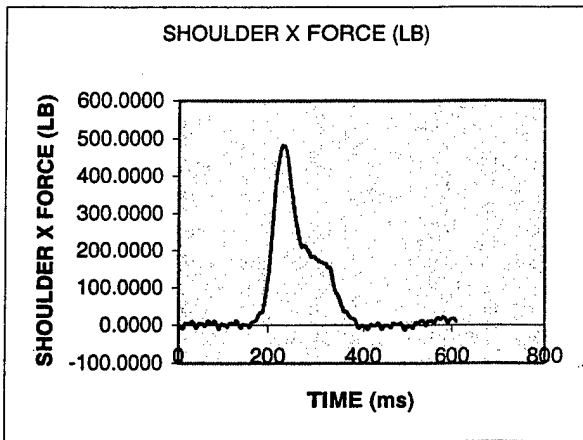
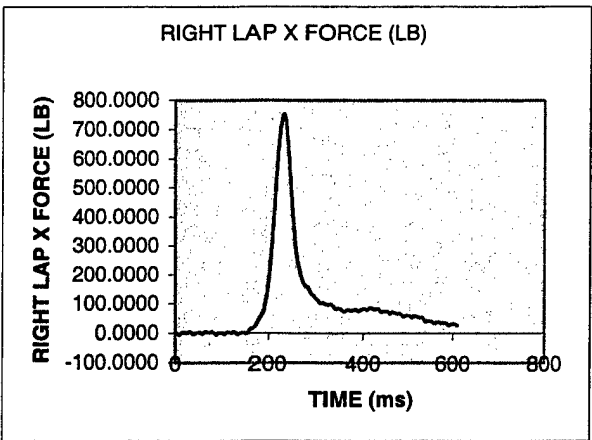
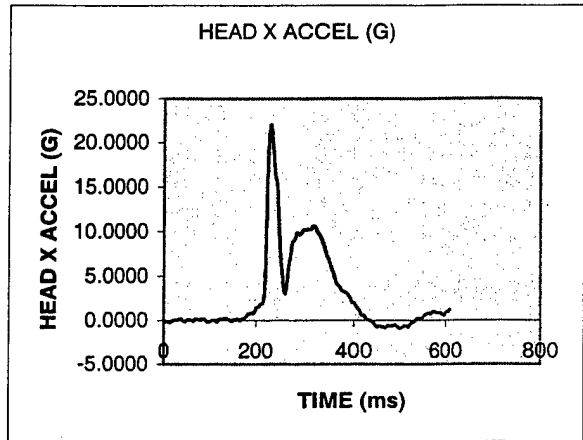
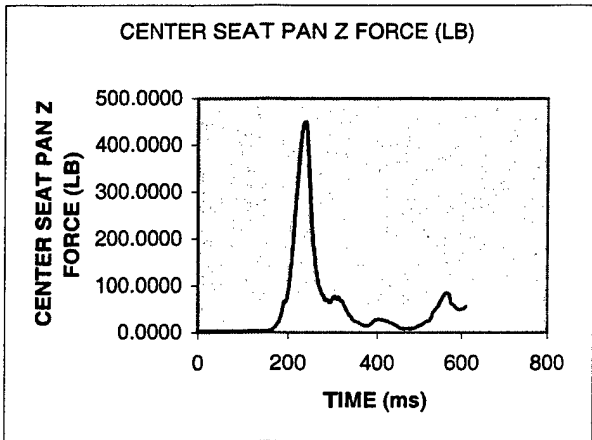
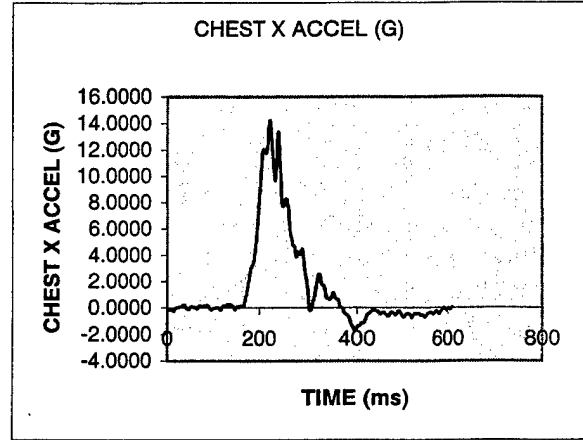
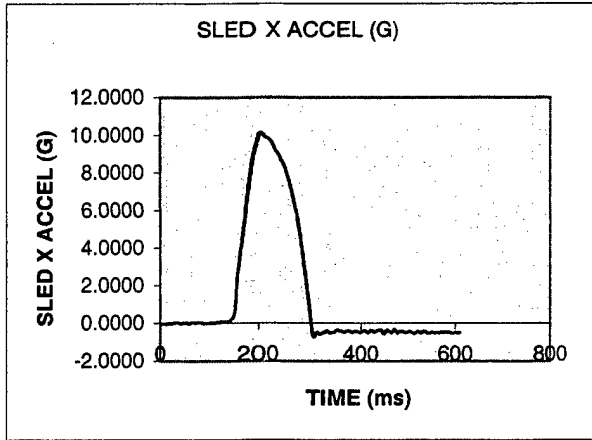

Test Subject HIA 1672 Cell C6

APPENDIX C
IMPACT SLED AND SEAT CONFIGURATION

Position	Seat Coordinates			Load Cell Function
	"X"	"Y"	"Z"	
1	0	0	0	Zero reference
2	-2.25	0.00	-1.00	Seat Load #3
3	-16.00	-5.2	-1.00	Seat Load #2
4	-16.00	+5.2	-1.00	Seat Load #1
5	+4.00	-4.75	-1.00	Seat Load #4
6	+4.00	+4.75	-1.00	Seat Load #5
7	+2.25	+9.55	-1.80	Left lap at "0"
8	-0.75	+9.55	-1.80	Left lap at "+3"
9	-0.75	-9.40	-1.75	Right lap at "+3"
10	+2.25	-9.40	-1.75	Right lap at "0"
11	See shoulder detail			Shoulder load

NOTES:

- Position 1 is at the center of the intersection of the seat back and seat pan.
- Triaxial load cell dimensions reference to center of clevis.
- Seat pan load cells (2, 3 and 4) dimensions reference to contact point on seat.
- Seat pan load cells (5 and 6) dimensions reference to the hinge point.
- Arrows indicate the direction of loading.
- Load cells at left lap, right lap and shoulder are triaxial cells.
- Shoulder load cell is adjustable along its "X" axis (see shoulder detail).
- Lap load cells are movable along their "Y" axis. Points 7 and 10 are designated "0" positions; points 8 and 9 are designated "+3" positions.
- Lap load cells are oriented with their "Y" axis parallel to the seat "X" axis. The clevis for the harness mounting is rotated 25° toward the seat.

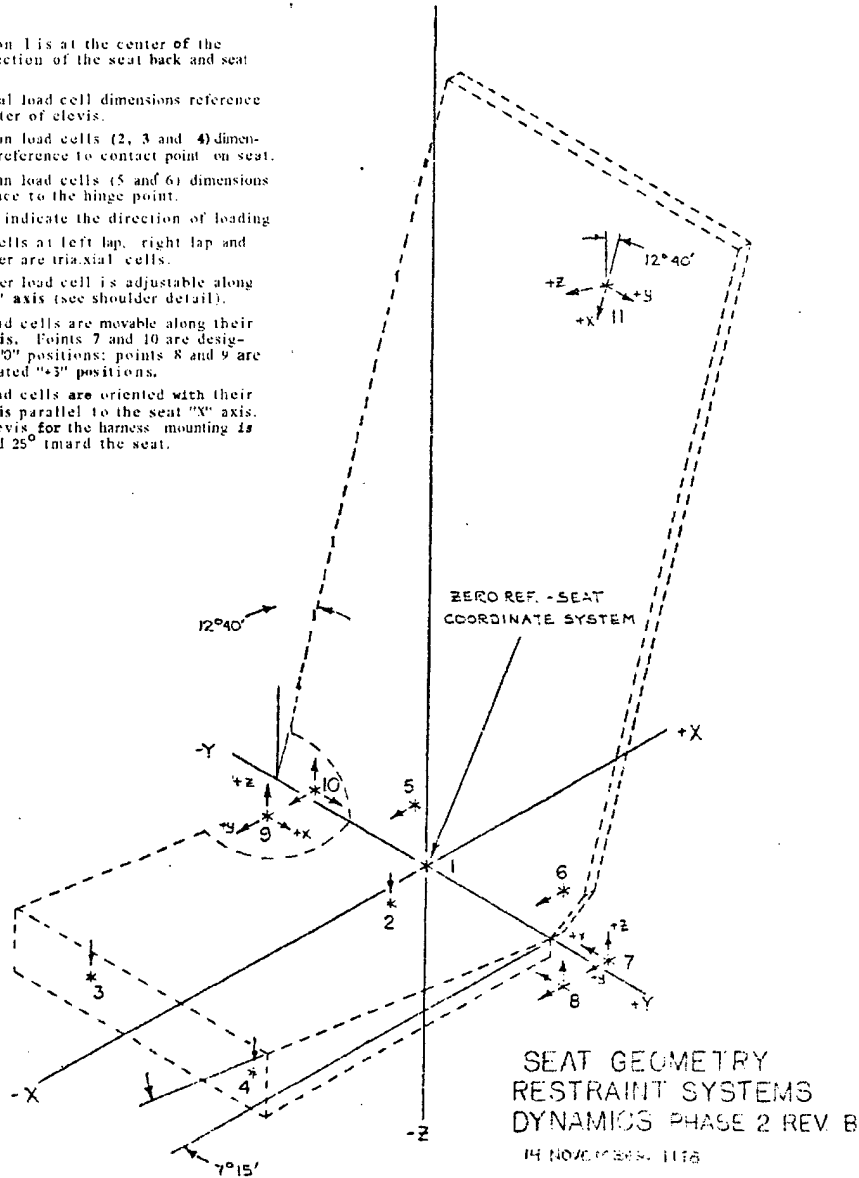

Seat Geometry

- NOTES:
- ① SEAT BACK & SHOULDER LOAD PLANE ARE PARALLEL.
 - ② SHOULDER LOAD CELL IS MOVABLE ALONG THE X AXIS ALTERING THE ANGLE OF PULL ON THE SHOULDER STRAPS (SEE INSERT)
 - ③ X₁ & Z₁ ARE VARIABLE WITH LOAD CELL POSITION (SEE ATTACHED PAGE)
 - ④ ANGULAR MEASUREMENTS ARE REFERENCED TO SLED FLOOR
 - ⑤ DRAWING NOT TO SCALE

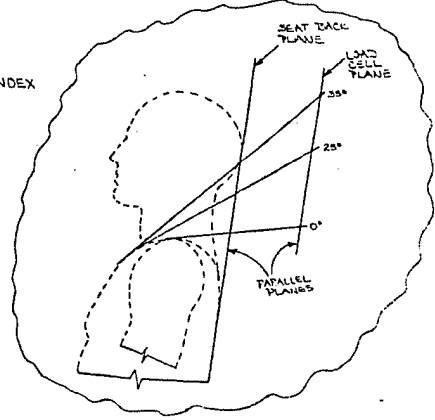
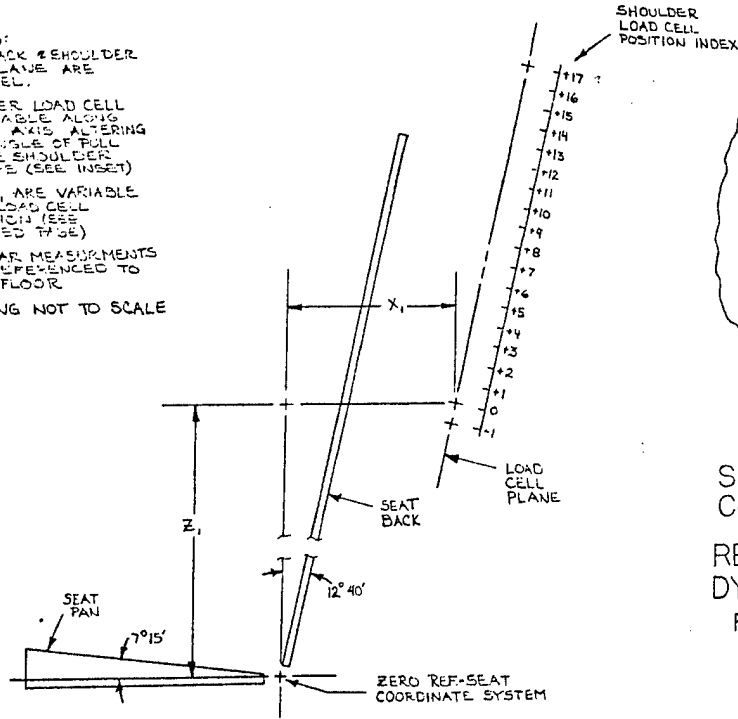

SHOULDER LOAD CELL DETAIL

RESTRAINT SYSTEMS DYNAMICS PROGRAM
PART 2 - REVISION B

14 NOVEMBER 1978

Shoulder Load Cell

Point No.	Axis (inches (centimeters))		
	X	Y	Z
Center Reference 1	0 (0)	0 (0)	0 (0)
Load Cell 2	-4.88 (-12.40)	0 (0)	-2.46 (-6.24)
Load Cell 3	-16.18 (-41.10)	-5.02 (-12.75)	-2.46 (-6.24)
Load Cell 4	-16.18 (-41.10)	+5.02 (+12.75)	-2.46 (-6.24)
Load Cell 5	-14.96 (-38.00)	0 (0)	-3.39 (-8.62)
Triaxial Load Cell 6	+1.57 (+4.00)	+9.00 (+22.86)	-1.77 (-4.50)
Triaxial Load Cell 7	+1.57 (+4.00)	-9.00 (-22.86)	-1.77 (-4.50)
Triaxial Load Cell 8	+11.83 (+30.00)	0 (0)	+26.78 (+68.00)
Load Link 9	-7.44 (-18.90)	-2.07 (-5.25)	-3.05 (-7.74)
Load Link 10	-8.23 (-20.90)	+6.00 (+15.25)	-3.05 (-7.74)
Load Link 11	-8.23 (-20.90)	-6.00 (-15.25)	-3.05 (-7.74)

* Rotating in XZ Plane

LOAD CELLS 5, 6, 7 & 8 PROVIDE A POSITIVE OUTPUT VOLTAGE WHEN BELT IS PULLED TO CENTER AXIS.

FIXED MOUNTED LOAD CELLS 2, 3, 4 AND LOAD LINKS 9, 10, 11 PROVIDE A POSITIVE OUTPUT VOLTAGE WHEN PRESSURE IS APPLIED AS SHOWN.

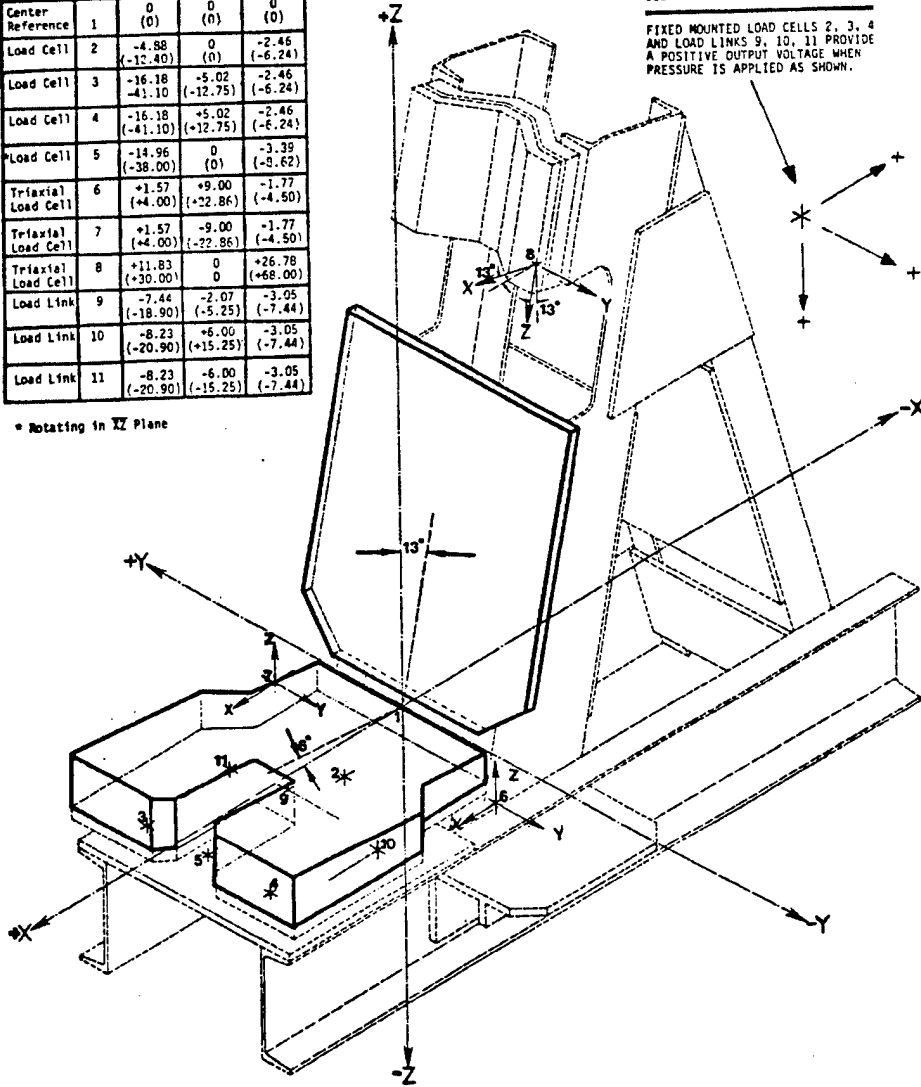

**RESTRAINT SYSTEM DYNAMICS
SEAT LOAD INSTRUMENTATION**

Seat Load Instrumentation