



**NAVAL
POSTGRADUATE
SCHOOL**

MONTEREY, CALIFORNIA

THESIS

**A COMPUTATIONAL STUDY OF THE EFFECT OF CROSS
WIND ON THE FLOW OF FIRE FIGHTING AGENT**

by

Alexandra Myers

June 2004

Thesis Advisor:

M.D. Kelleher

Thesis Co-Advisor:

G.V. Hobson

Approved for public release; distribution is unlimited

THIS PAGE INTENTIONALLY LEFT BLANK

REPORT DOCUMENTATION PAGE			Form Approved OMB No. 0704-0188	
Public reporting burden for this collection of information is estimated to average 1 hour per response, including the time for reviewing instruction, searching existing data sources, gathering and maintaining the data needed, and completing and reviewing the collection of information. Send comments regarding this burden estimate or any other aspect of this collection of information, including suggestions for reducing this burden, to Washington headquarters Services, Directorate for Information Operations and Reports, 1215 Jefferson Davis Highway, Suite 1204, Arlington, VA 22202-4302, and to the Office of Management and Budget, Paperwork Reduction Project (0704-0188) Washington DC 20503.				
1. AGENCY USE ONLY (Leave blank)		2. REPORT DATE June 2004	3. REPORT TYPE AND DATES COVERED Master's Thesis	
4. TITLE AND SUBTITLE: A Computational Study of the Effect of Cross Wind on the Flow of Fire Fighting Agent			5. FUNDING NUMBERS	
6. AUTHOR(S) Alexandra Myers				
7. PERFORMING ORGANIZATION NAME(S) AND ADDRESS(ES) Naval Postgraduate School Monterey, CA 93943-5000			8. PERFORMING ORGANIZATION REPORT NUMBER	
9. SPONSORING /MONITORING AGENCY NAME(S) AND ADDRESS(ES) N/A			10. SPONSORING/MONITORING AGENCY REPORT NUMBER	
11. SUPPLEMENTARY NOTES The views expressed in this thesis are those of the author and do not reflect the official policy or position of the Department of Defense or the U.S. Government.				
12a. DISTRIBUTION / AVAILABILITY STATEMENT Approved for public release; distribution is unlimited			12b. DISTRIBUTION CODE	
13. ABSTRACT (maximum 200 words) This research will be used to evaluate the feasibility of robotically, or remote-controlled firefighting nozzles aboard air-capable ships. A numerical model was constructed and analyzed, using the program CFD-ACE, of a fire hose stream being deflected by the influence of a crosswind, tailwind, or headwind. The model is intended to predict the reach of the fire hose stream, indicate the distribution pattern, and estimate the volume of fire fighting agent available at the end of the stream. Preliminary results for a two fluid cross flow model have been obtained.				
14. SUBJECT TERMS Damage Control, Computational Fluid Dynamics Modeling, Aircraft Carrier Flight Deck Fire, Fluid Jet Stream, Air Cross Wind, Flight Deck Firefighting			15. NUMBER OF PAGES 85	
			16. PRICE CODE	
17. SECURITY CLASSIFICATION OF REPORT Unclassified	18. SECURITY CLASSIFICATION OF THIS PAGE Unclassified	19. SECURITY CLASSIFICATION OF ABSTRACT Unclassified	20. LIMITATION OF ABSTRACT UL	

NSN 7540-01-280-5500

Standard Form 298 (Rev. 2-89)
Prescribed by ANSI Std. 239-18

THIS PAGE INTENTIONALLY LEFT BLANK

Approved for public release; distribution is unlimited

**A COMPUTATIONAL STUDY OF THE EFFECT OF CROSS WIND ON THE
FLOW OF FIRE FIGHTING AGENT**

Alexandra Myers
Ensign, United States Navy
B.S., United States Naval Academy, 2003

Submitted in partial fulfillment of the
requirements for the degree of

MASTER OF SCIENCE IN MECHANICAL ENGINEERING

from the

**NAVAL POSTGRADUATE SCHOOL
June 2004**

Author: Alexandra Myers

Approved by: Matthew D. Kelleher
Thesis Advisor

Garth V. Hobson
Thesis Co-Advisor

Anthony J. Healey,
Chairman, Department of Mechanical and
Astronautical Engineering

THIS PAGE INTENTIONALLY LEFT BLANK

ABSTRACT

This research will be used to evaluate the feasibility of robotically, or remote-controlled firefighting nozzles aboard air-capable ships. A numerical model was constructed and analyzed, using the program CFD-ACE, of a fire hose stream being deflected by the influence of a crosswind, tailwind, or headwind. The model is intended to predict the reach of the fire hose stream, indicate the distribution pattern, and estimate the volume of fire fighting agent available at the end of the stream. Preliminary results for a two fluid cross flow model have been obtained.

THIS PAGE INTENTIONALLY LEFT BLANK

TABLE OF CONTENTS

I.	INTRODUCTION	1
A.	BACKGROUND	1
B.	PROBLEM DESCRIPTION	6
II.	METHODOLOGY AND FORMULATION	7
A.	MODEL GEOMETRY	7
1.	Grid Formation	7
2.	Boundary Conditions	11
3.	Volume Conditions	13
B.	CALCULATIONS	13
III.	RESULTS	15
IV.	CONCLUSIONS	21
V.	RECOMMENDATIONS	23
	LIST OF REFERENCES	25
	BIBLIOGRAPHY	27
APPENDIX A.	GRID FORMATION	31
APPENDIX B.	SAMPLE INPUTS (TRIAL 1)	35
APPENDIX C.	TRIAL 2	43
APPENDIX D.	TRIAL 3	47
APPENDIX E.	TRIAL 4	51
APPENDIX F.	TRIAL 5	55
APPENDIX G.	TRIAL 6	59
APPENDIX H.	TRIAL 7	63
APPENDIX I.	TRIAL 8	67
APPENDIX J.	TRIAL 9	67
	INITIAL DISTRIBUTION LIST	71

THIS PAGE INTENTIONALLY LEFT BLANK

LIST OF FIGURES

Figure 1.	Plan View without Grid.	8
Figure 2.	Plan View with Grid.	9
Figure 3.	Two-Dimensional Cross Section.	10
Figure 4.	1 (in) Nozzle Grid Spacing.	11
Figure 5.	Crosswind Boundary in Red.	12
Figure 6.	Environmental Pressure Boundaries in Red.	13
Figure 7.	Residuals: Trial 1.	15
Figure 8.	Plan View: Trial 1, 15 (kts).	16
Figure 9.	Side View: Trial 1, 15 (kts).	17
Figure 10.	Angled View: Trial 1, 15 (kts).	17
Figure 11.	Plan View: Trial 1, 30 (kts).	18
Figure 12.	Side View: Trial 1, 30 (kts).	19
Figure 13.	Angled View: Trial 1, 30 (kts).	19
Figure 14.	2 (in) Nozzle Grid Spacing.	31
Figure 15.	3 (in) Nozzle Grid Spacing.	32
Figure 16.	Side View without Grid.	33
Figure 17.	Side View with Grid.	33
Figure 18.	Plan View: Trial 2, 15 (kts).	39
Figure 19.	Side View: Trial 2, 15 (kts).	40
Figure 20.	Angled View: Trial 2, 15 (kts).	40
Figure 21.	Plan View: Trial 2, 30 (kts).	41
Figure 22.	Side View: Trial 2, 30 (kts).	42
Figure 23.	Angled View: Trial 2, 30 (kts).	42
Figure 24.	Plan View: Trial 3, 15 (kts).	43
Figure 25.	Side View: Trial 3, 15 (kts).	44
Figure 26.	Angled View: Trial 3, 15 (kts).	44
Figure 27.	Plan View: Trial 3, 30 (kts).	45
Figure 28.	Side View: Trial 3, 30 (kts).	46
Figure 29.	Angled View: Trial 3, 30 (kts).	46
Figure 30.	Plan View: Trial 4, 15 (kts).	47
Figure 31.	Side View: Trial 4, 15 (kts).	48
Figure 32.	Angled View: Trial 4, 15 (kts).	48
Figure 33.	Plan View: Trial 4, 30 (kts).	49
Figure 34.	Side View: Trial 4, 30 (kts).	50
Figure 35.	Angled View: Trial 4, 30 (kts).	50
Figure 36.	Plan View: Trial 5, 15 (kts).	51
Figure 37.	Side View: Trial 5, 15 (kts).	52
Figure 38.	Angled View: Trial 5, 15 (kts).	52
Figure 39.	Plan View: Trial 5, 30 (kts).	53
Figure 40.	Side View: Trial 5, 30 (kts).	54
Figure 41.	Angled View: Trial 5, 30 (kts).	54
Figure 42.	Plan View: Trial 6, 15 (kts).	55

Figure 43.	Side View: Trial 6, 15 (kts).	56
Figure 44.	Angled View: Trial 6, 15 (kts).	56
Figure 45.	Plan View: Trial 6, 30 (kts).	57
Figure 46.	Side View: Trial 6, 30 (kts).	58
Figure 47.	Angled View: Trial 6, 30 (kts).	58
Figure 48.	Plan View: Trial 7, 15 (kts).	59
Figure 49.	Side View: Trial 7, 15 (kts).	60
Figure 50.	Angled View: Trial 7, 15 (kts).	60
Figure 51.	Plan View: Trial 7, 30 (kts).	61
Figure 52.	Side View: Trial 7, 30 (kts).	62
Figure 53.	Angled View: Trial 7, 30 (kts).	62
Figure 54.	Plan View: Trial 8, 15 (kts).	63
Figure 55.	Side View: Trial 8, 15 (kts).	64
Figure 56.	Angled View: Trial 8, 15 (kts).	64
Figure 57.	Plan View: Trial 8, 30 (kts).	65
Figure 58.	Side View: Trial 8, 30 (kts).	66
Figure 59.	Angled View: Trial 8, 30 (kts).	66
Figure 60.	Plan View: Trial 9, 15 (kts).	67
Figure 61.	Side View: Trial 9, 15 (kts).	68
Figure 62.	Angled View: Trial 9, 15 (kts).	68
Figure 63.	Plan View: Trial 9, 30 (kts).	69
Figure 64.	Side View: Trial 9, 30 (kts).	70
Figure 65.	Angled View: Trial 9, 30 (kts).	70

LIST OF TABLES

Table 1.	Jet Stream Velocity and Reynolds Numbers.	14
Table 2.	Summary of Trials.	20

THIS PAGE INTENTIONALLY LEFT BLANK

I. INTRODUCTION

A. BACKGROUND

The Navy is presently attempting to reduce the cost of operating and maintaining the fleet, and manpower is a major area under scrutiny. There is great concern with the concept of reduced manpower and its effect on the damage control capabilities aboard ship. In order to reduce manpower the ability to automate ship systems is essential.

Within damage control automation the technologies that are being sought and implemented are fixed automatic firefighting systems, improved damage control communications, self-reconfiguring systems, flood control systems, and fixed boundary cooling. It is believed that automated firefighting systems will be beneficial to controlling fires since the crucial time to achieve control is within the first 3-5 minutes of the start of the fire. Automated systems activate more quickly than a human response team.

In order to obtain optimal systems and procedures for ships with reduced manpower the Office of Naval Research (ONR) is sponsoring two Naval Research Laboratory programs, the Damage Control Automation for Reduced Manning (DC-ARM) and Integrated Survivability Fleet Evaluation (ISFE). In September 1998, the first successful demonstration of a 35% reduction in damage control manpower on the test platform, ex-USS Shadwell (LSD 15), was performed. The next goal is to reach a 60% reduction in manpower. [Ref. 1]

The concept of fire extinguishment is based in the idea of the fire triangle where a fire consists of three sides of the triangle representing fuel, oxygen, and heat.

If either of the three is removed then the fire will be extinguished. Firefighting agents can achieve this through physical or chemical means. There are four basic physical means: 1) Smothering the fire, where the fuel and air are separated. This concept is behind foam extinguishers. 2) The removal of heat. Agents with high heat capacities can provide the means for heat removal by absorbing the heat from the fire. 3) Forcing a high velocity gas over the flame to separate the fuel and air or the fuel and heat. 4) Flame radiation blockage, where the agent absorbs thermal radiation between the surface of the fuel and the flame for liquid or solid fuels. Fire extinguishment via chemical means occurs by using an agent that interferes with the chemical reaction that sustains combustion. [Ref. 2]

Presently, the Navy uses a variety of firefighting agents including Halon 1301, Halon 1211, Aqueous Film-Forming Foam (AFFF), CO₂, and potassium bicarbonate powder (PKP). Water mist systems are the likely candidate for future ships. Halon 1301 is used in enclosed spaces by gas-phase catalytic interruption of combustion reactions. Halon 1211 is used for streaming applications such as fires in engines that result from the pooling of fuel when an aircraft engine does not start, as well as large three-dimensional cascading flight deck fires. AFFF is 6% Foam and 94% water. It is used to extinguish two-dimensional pool fires. AFFF, CO₂, and PKP are all used within portable extinguishers for first-response fire fighting. [Ref. 2]

Halon has been found to damage the ozone layer and production of this material was halted on 31 December 1993 due to international treaties and US legislation. The Navy

maintains a strategic reserve of Halon since it is mission critical for the Navy. [Ref.3] Therefore, it is necessary for the Navy to find a suitable replacement where Halon is used. No substance with the same qualities that Halon possesses has been found. However, there are a few possibilities for Halon 1301 replacement. One being fine-aerosol generation, which is where a solid propellant is burned and a fine, fire-fighting aerosol is released. It retains the same fire-fighting capability as Halon 1301 with better weight and space requirements. Fine-aerosol generation is not preferable because it is difficult to manage the "high temperature of the burning propellant and the non-clean-agent residue that can be both toxic to humans and corrosive to shipboard systems". [Ref. 4, p.109] Another possibility for replacement is heptafluoropropane (HFP). The drawback for using HFP is a greater requirement for space and weight than Halon 1301. A third possibility is hydrofluorocarbons such as HFC-227 (FM200). FM200 can be utilized in occupied as well as unoccupied spaces. However, its drawbacks include the inability to be piped over long distances and it has a low boiling point. [Ref. 5] The final possibility is water mist technology. The only replacement for Halon 1211 being considered is halocarbons. There is still a great deal of testing that needs to be done to determine toxicity to humans and possible environmental impacts. [Ref.6]

Water mist systems are defined by producing a droplet size smaller than 500 microns. These types of systems are a desirable alternative because they use a small amount of water and are lower in weight. [Ref. 7]

Water mist systems can use as little as 2% of the water normally used by conventional water systems. Water mist extinguishes fires quickly, cools radiant heat from surrounding equipment to eliminate any risk of re-ignition, and permits almost immediate access to an affected space. Overall, water mist is probably the best alternative to halon and all other gaseous systems. [Ref. 8,p. 1]

On May 26, 1981, an EA-6B aircraft crashed into several parked F-14's while attempting to land on the USS NIMITZ (CVN-68). As a result of the crash and the ensuing fire and explosions, 14 persons were killed and 42 injured. [Ref 9, p. 1]

The Board of Investigation found the level of disaster to be due to several deficiencies within equipment and techniques. This drove the Naval Research Laboratory to investigate improvements to firefighting tactics on flight deck fires by evaluating various firefighting techniques such as different firefighting agents, the application of those agents under various wind conditions, and their ability to extinguish a variety of fires. Specifically, seawater versus AFFF, 1-1/2 in. and 2-1/2 in hand lines in various wind conditions, effective range of monitors (water cannons having flow capabilities from 500 to 12,000 gpm) in various wind conditions, running fuel fires, and debris pile fires. [Ref. 9]

One of the greatest inhibiting factors is being able to "approach an area where the incident heat flux level exceeds the protection of a fire proximity suit." [Ref. 10, p. 1] Due to these inhibitions, Remote Controlled Firefighting Platforms (RCFP) have been developed and tested. Another advantage of the RCFP is the ability to approach a fire from the downwind side. Two prototypes

produced by the Naval Surface Weapons Center are the Firecat, a battery-powered, tracked vehicle, and the Firefox, a gasoline driven, skid steer vehicle. After testing the vehicles in various wind conditions and comparing the results to hand lines it was found that in certain situations the hand lines extinguished the fire more quickly due to the ability to employ a firefighting technique of rapidly moving the stream of foam back and forth. However, the RCFP's proved to be an asset in certain situations. "The vehicles were able to maneuver into close proximity (less than 8m) and extinguish or control 34 of the 45 test fires in 150 seconds or less. These fires would have been difficult or impossible for unprotected hose line crews to extinguish, particularly in a downwind approach." [Ref. 10, p. 25]

Regardless of the firefighting agent in use, wind conditions will always be a significant factor in their application on a flight deck. The amount of deflection of the agent being applied due to wind conditions is essential information in applying firefighting tactics. The amount and direction of deflection will determine how and where the firefighting agent needs to be applied for optimal extinguishing effects. Computational Fluid Dynamics (CFD) modeling can provide the insight of wind effects upon the application of firefighting agents. Many different wind conditions and options for the application of firefighting agents can be tested and evaluated at a low cost using CFD modeling. Field-testing still needs to be performed to evaluate the validity of the CFD modeling. The findings from this type of modeling and testing can be used on future flight decks of aircraft carriers with respect to

the types of deliverance methods of firefighting agents and their placement around the flight deck in order to optimize firefighting capabilities under various wind conditions. This study uses CFD modeling to evaluate the jet stream flow development and deflection at the exit of a nozzle in a cross flow of wind.

B. PROBLEM DESCRIPTION

The purpose of this study is to construct a Computational Fluid Dynamics (CFD) model to analyze a fire hose stream being deflected by the influence of a crosswind, tailwind, or headwind. The model is intended to predict the stream reach, indicate the distribution pattern, and estimate the volume of fire fighting agent available at the end of the stream. This study concentrates on a model of the flow development and deflection for various jet stream velocities and cross flows of wind near the exit of the nozzle.

CFD-GEOM, CFD-ACE, and CFD-VIEW version 2003, commercial CFD programs produced by the Computational Fluid Dynamics Research Corporation (CFDRC) were used in the construction of the model and analysis. The modeling and analysis was done on Micron Pro Desktop computer, with a 400 MHz processor, 384 megabytes of RAM and a 12-gigabyte internal hard drive.

II. METHODOLOGY AND FORMULATION

A. MODEL GEOMETRY

1. Grid Formation

The model was constructed to represent a fire hose with a jet stream of water exiting parallel to the flight deck. The model represents a small volume of area near the nozzle exit. The three-dimensional volume consists of the pipe, with a total length of 27.559-in (0.7-m), protruding into a box with a total length of 39.37-in (1.0-m). The pipe protrudes into the box a length of 7.874-in (0.2-m). The plan view of the volume without the grid is shown in Figure 1. The plan view of the volume with the grid is shown in Figure 2. Images of the volume from the side view can be found in Appendix A.

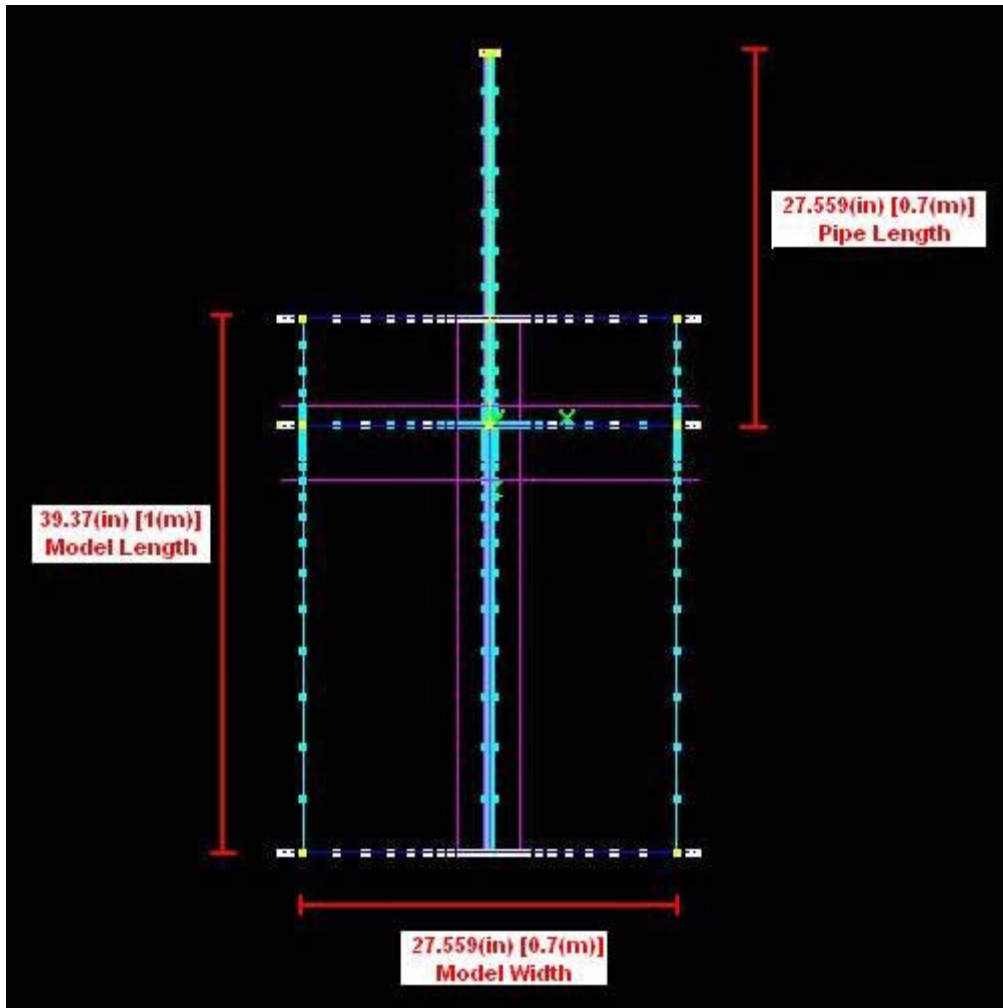

Figure 1. Plan View without Grid.

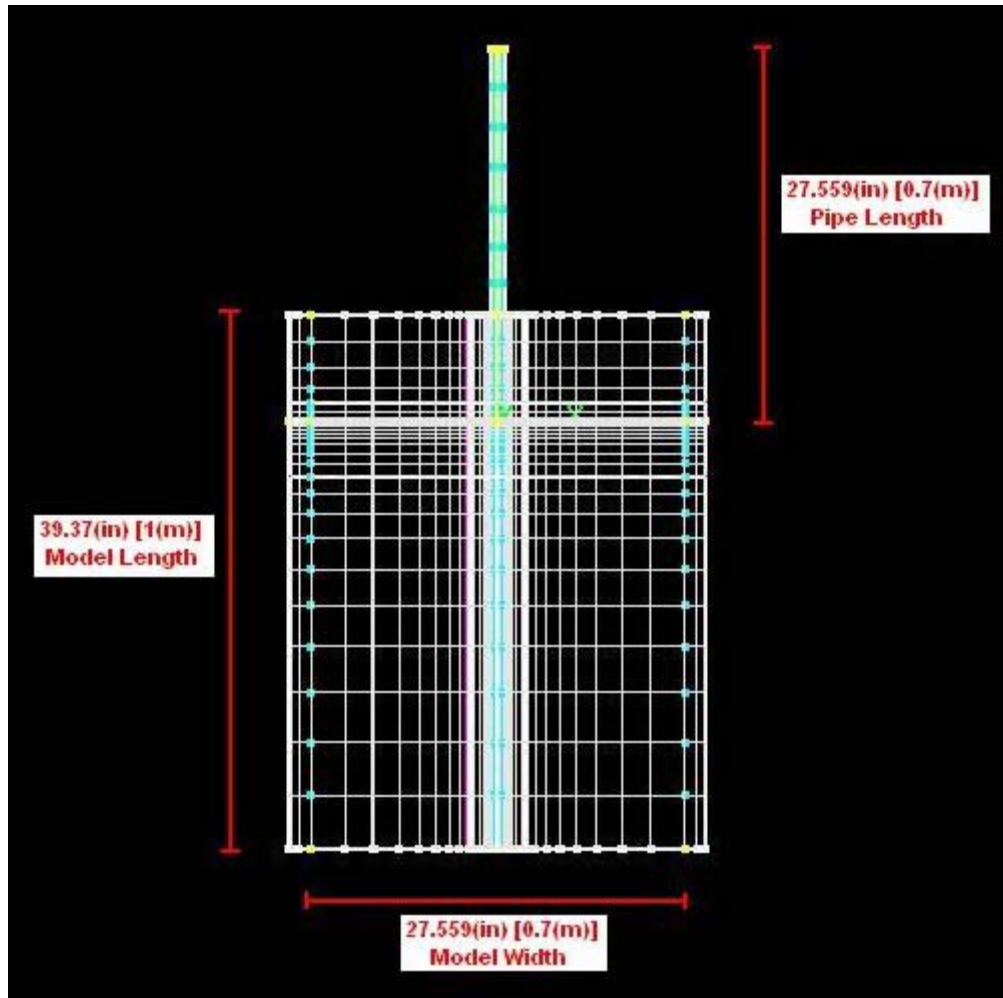

Figure 2. Plan View with Grid.

The grid spacing varies over the length of the volume and finer grid spacing is in place closer to the nozzle exit, which is necessary for the solver to resolve a solution. The grid spacing increases with increasing distance from the nozzle. The complete volume contains 16,044 cells.

The construction of the model began with a two-dimensional cross section of the volume within CFD-GEOM. The two-dimensional cross section was then extruded to create the three-dimensional volume. The complete two-dimensional cross section of the grid is shown in Figure 3.

The sides of the two-dimensional shape are representative of the flight deck, crosswind, and environment on the three-dimensional volume. The sides are rounded to maintain the grid shape except on the bottom, which is necessary to be flat as it represents the flight deck.

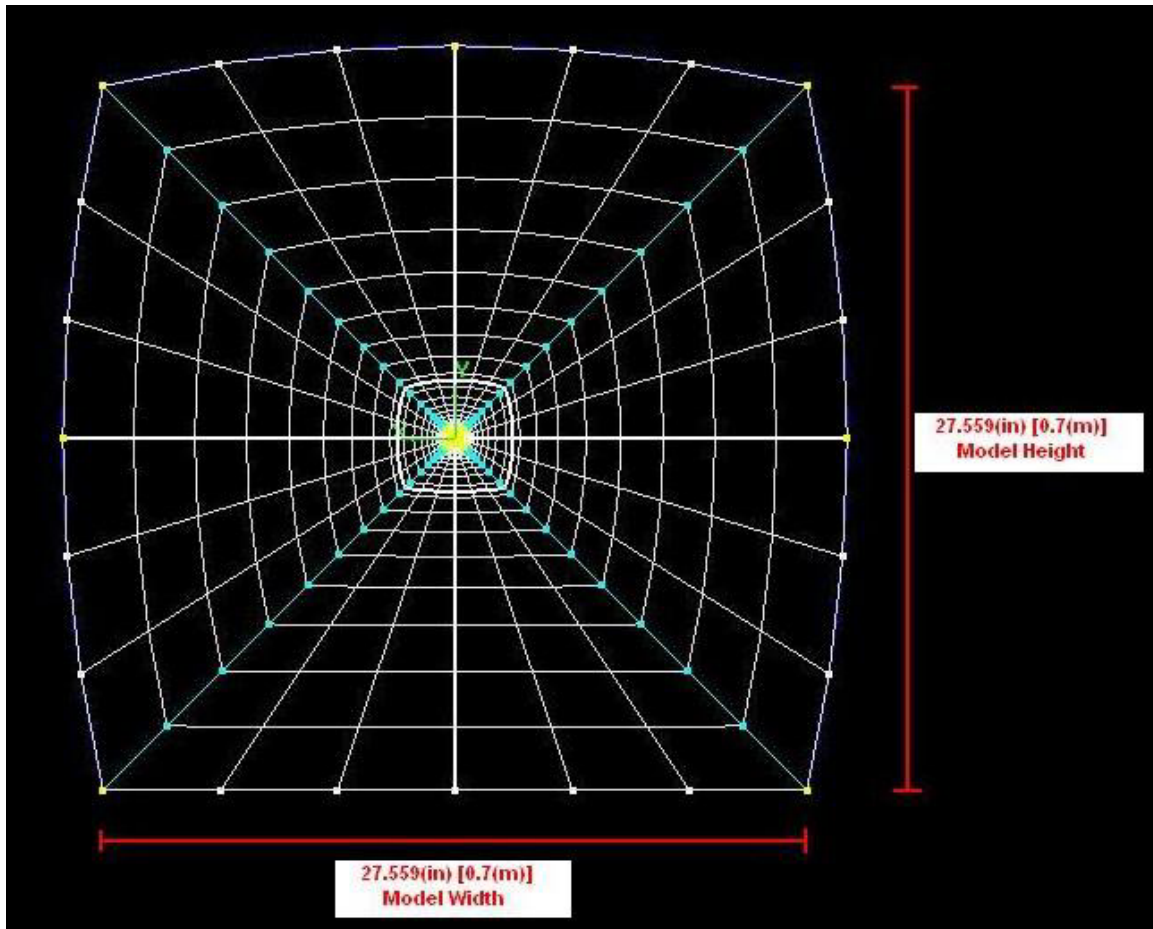

Figure 3. Two-Dimensional Cross Section.

At the center of the cross section the one-inch nozzle was constructed. A smaller box with rounded sides within the one-inch nozzle was constructed to prevent grid deformation. Figure 4 is an image of the one-inch nozzle with grid spacing.

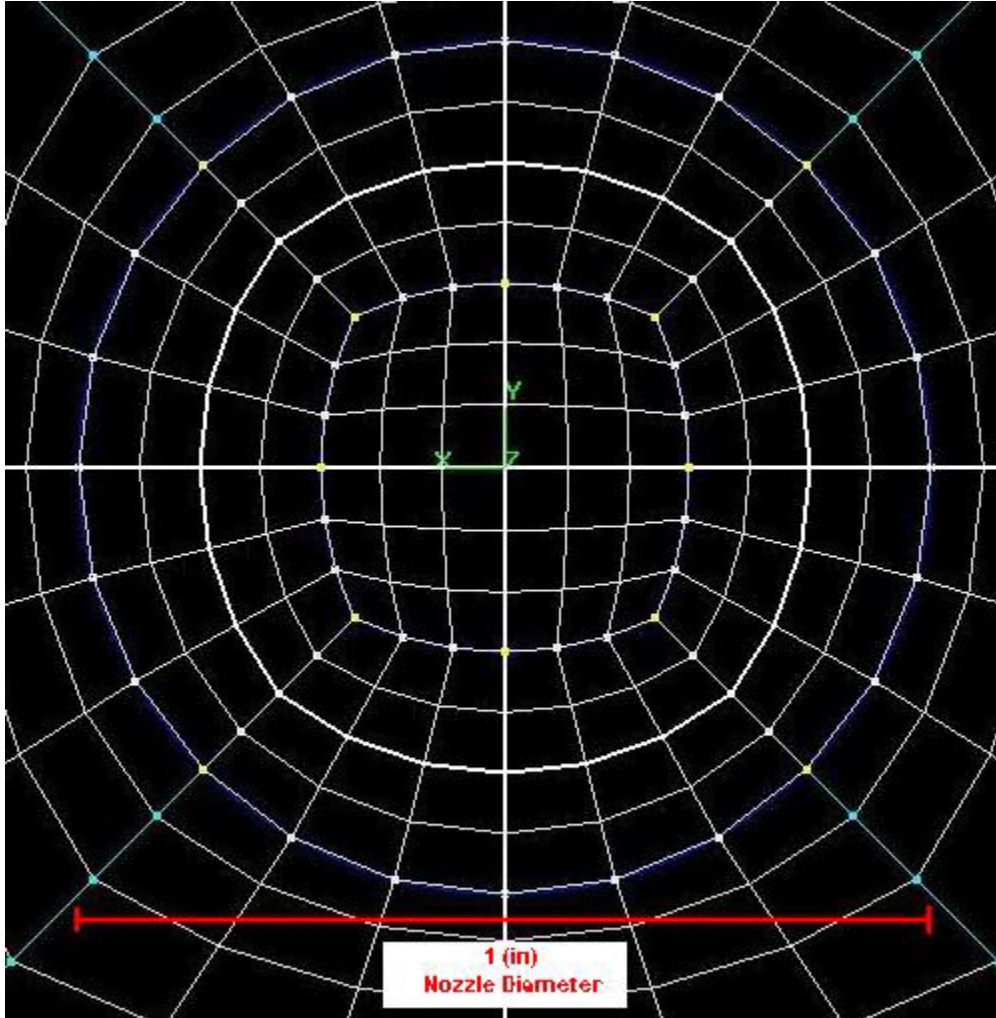

Figure 4.1 (in) Nozzle Grid Spacing.

The same methodology was applied for creating the grid formation for the two-inch and three-inch nozzles as well as the volumes for the models with a two and three inch nozzle. The only difference between the models is the size of the pipe and nozzle diameter. Images of the grids for these nozzles are located in Appendix A.

2. Boundary Conditions

The boundary conditions have been set on the volume to simulate the environment at the jet stream exit from the nozzle. The crosswind flows in the positive x-direction

across the flight deck. The wind velocity was set to constant velocities of fifteen [7.716 (m/s)] and thirty [15.64 (m/s)] knots for various trials. The crosswind boundary is highlighted in red in Figure 5.

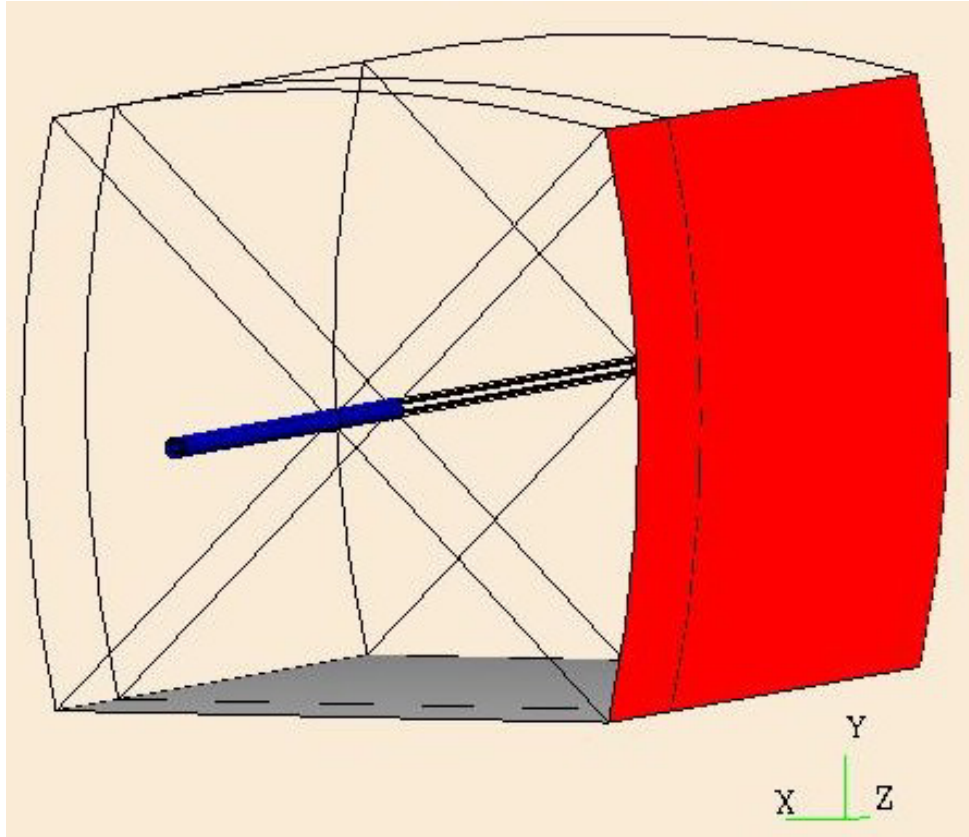

Figure 5. Crosswind Boundary in Red.

All of the other boundaries were set to a constant environmental pressure of 101325 (N/m²). These boundaries are highlighted in red in Figure 6.

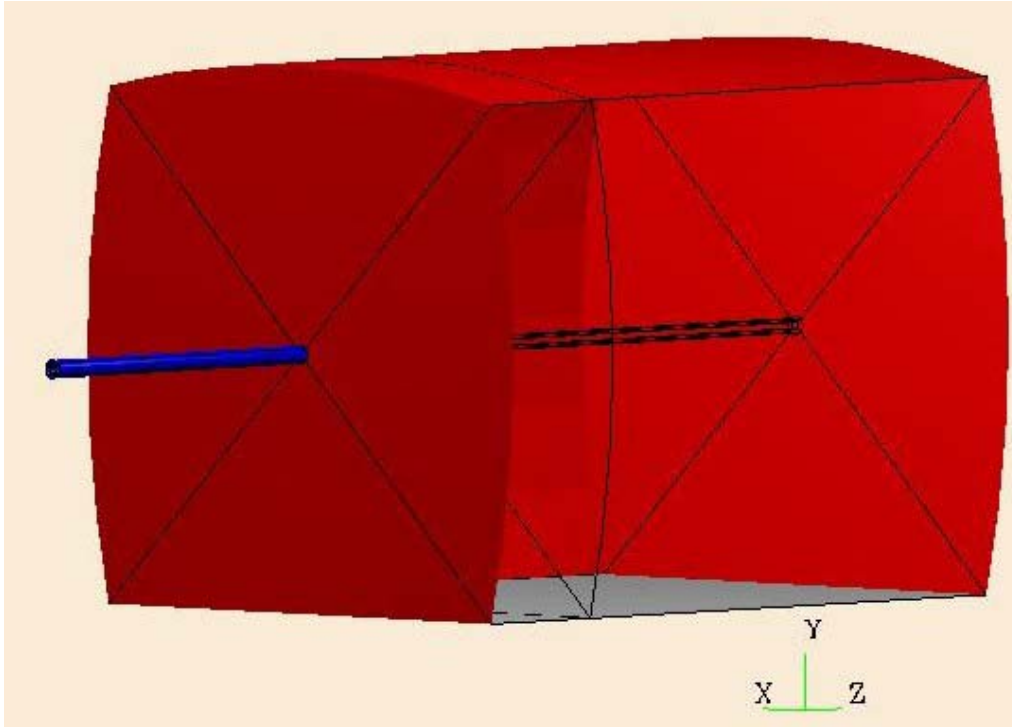

Figure 6. Environmental Pressure Boundaries in Red.

3. Volume Conditions

The Volume of Fluid Problem Type under transient conditions was set within CFD-ACE. The volume of fluid representing the jet stream exiting the nozzle is water with a constant density of $1000(\text{kg}/\text{m}^3)$ and a constant kinematic viscosity of $1\text{E}-6$ (m^2/s). It is exiting the nozzle into a volume of air with a constant density of 1.1614 (kg/m^3) and a constant dynamic viscosity of $1.846\text{E}-5$ (m^2/s). Refer to Appendix B for sample inputs to CFD-ACE from Trial 1.

B. CALCULATIONS

The analysis done on the models used flow rates of 125, 250, and 500 (GPM). The flow rates were then used to calculate velocities for the jet stream at the nozzle exit. These were the inputs used for CFD-ACE. Reynolds numbers

were also calculated for each of the flow rates. These calculations are summarized in Table 1.

$$V = \frac{m}{\rho A}$$

$$Re = \frac{\rho V D}{\mu}$$

V=velocity

m=mass flow rate

ρ=density

A=area

D=Diameter

μ=viscosity

NOZZLE DIAMETER (in)	NOZZLE DIAMETER (ft)	AREA (ft ²)
1	0.0833	0.0055
2	0.1667	0.0218
3	0.2500	0.0491

	FLOW RATE (GPM)		
	125	250	500
	FLOW RATE (ft ³ /s)		
	0.2785	0.5569	1.1139
NOZZLE DIAMETER (in)	VELOCITY (ft/s)		
1	25.6565	51.3131	102.6261
2	6.4141	12.8283	25.6565
3	2.8507	5.7015	11.4029
NOZZLE DIAMETER (in)	VELOCITY (m/s) (1m/s)=(1ft/s)(0.3048)		
1	7.8201	15.6402	31.2804
2	1.9550	3.9101	7.8201
3	0.8689	1.7378	3.4756
NOZZLE DIAMETER (in)	Reynolds Numbers		
1	169510.3057	339020.6115	678041.223
2	84755.15287	169510.3057	339020.6115
3	56503.43525	113006.8705	226013.741

Table 1. Jet Stream Velocity and Reynolds Numbers.

III. RESULTS

For each variable such as the velocity components and pressure, residuals are calculated for each cell, weighted by the cell volume, and then summed over the entire model. A residual reduction of five orders of magnitude is desired to ensure that solution convergence is achieved. [Ref. 11] The velocity components in the first trial achieved a residual reduction of six orders of magnitude and the pressure variable achieved a residual reduction of five orders of magnitude. Similar residuals were achieved for all subsequent trials in this study. The residuals achieved for the first trial is depicted in Figure 7, and is representative of the results for all the trials in this study.

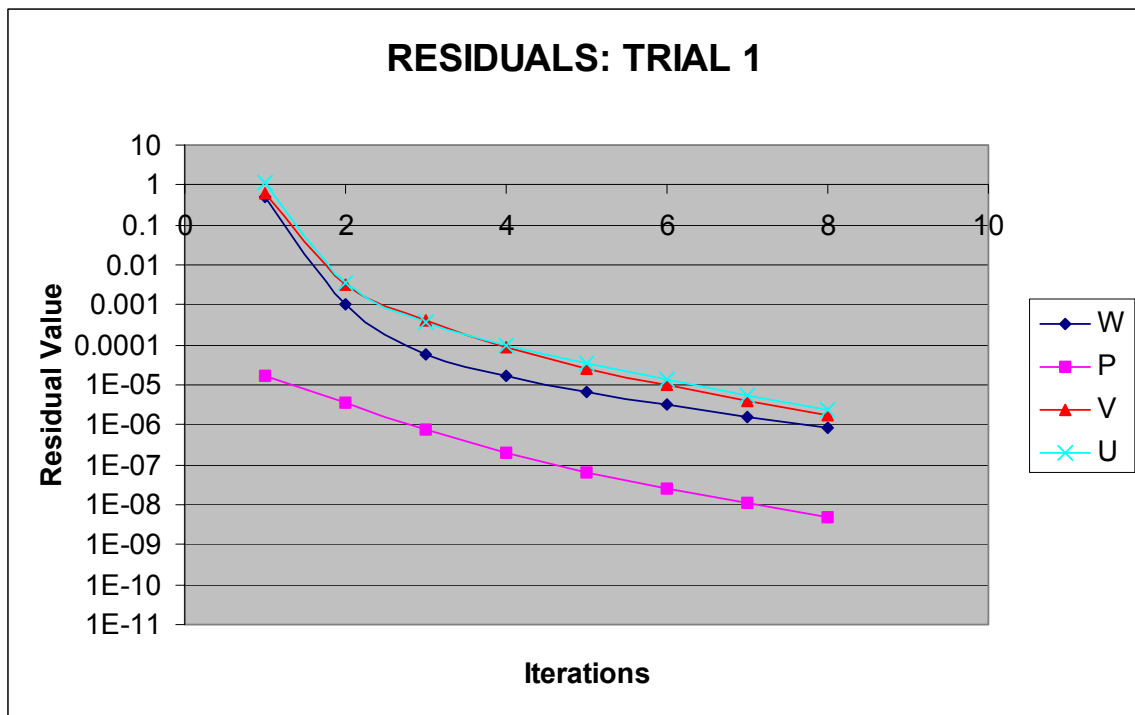

Figure 7. Residuals: Trial 1.

Trial 1 was tested for a 1 (in) nozzle with a flow rate of 125 (GPM) in cross winds of 15 and 30 knots. The amount of deflection of the jet stream due to a cross wind of 15 (kts) is displayed in the plan view of the volume of fluid flow in Figure 8. A side and angled view are also displayed in Figures 9 and 10 to obtain an improved visualization of the wind effects.

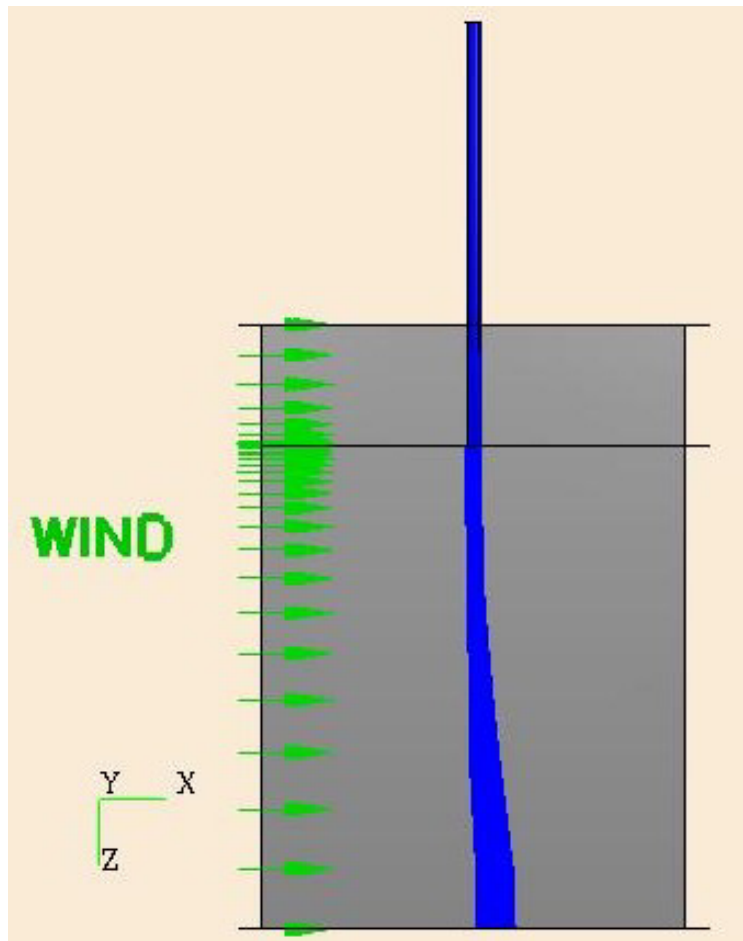

Figure 8. Plan View: Trial 1, 15 (kts).

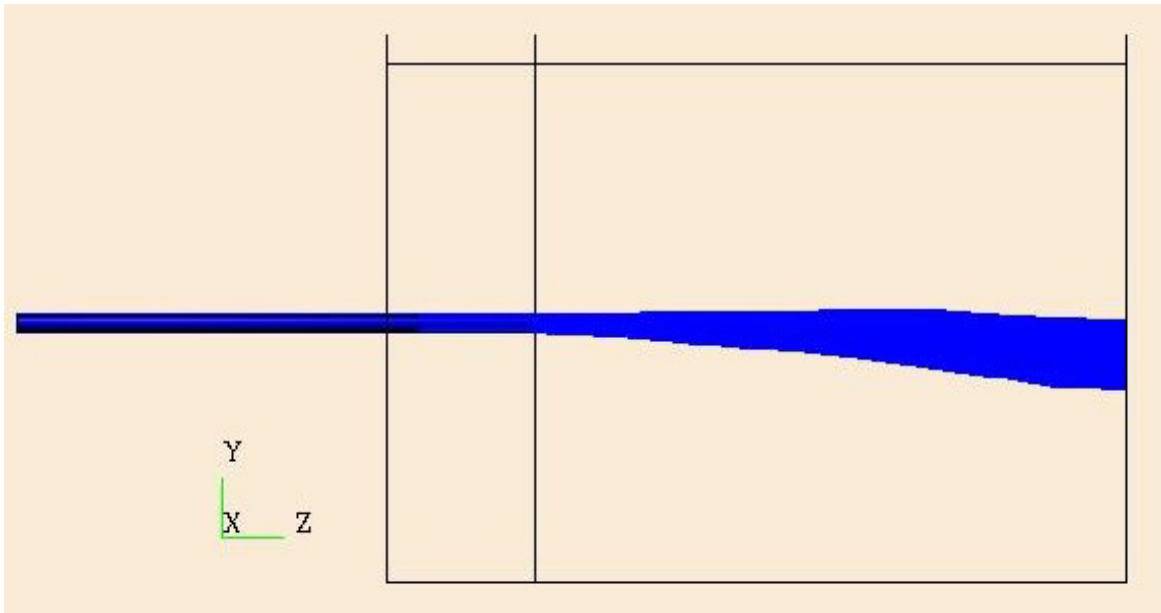

Figure 9. Side View: Trial 1, 15 (kts).

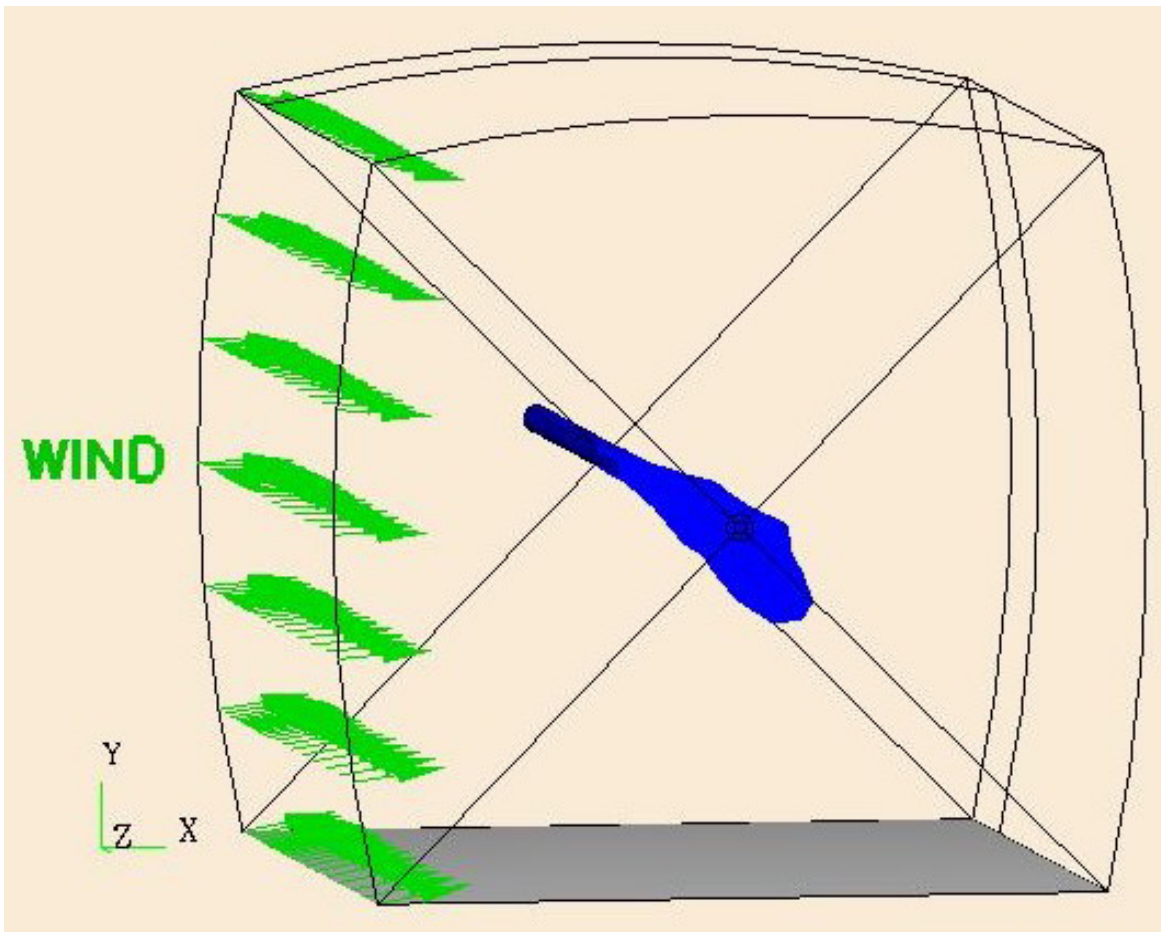

Figure 10. Angled View: Trial 1, 15 (kts).

The wind effects for 30 (kts) of wind are displayed in the following Figures 11, 12, and 13.

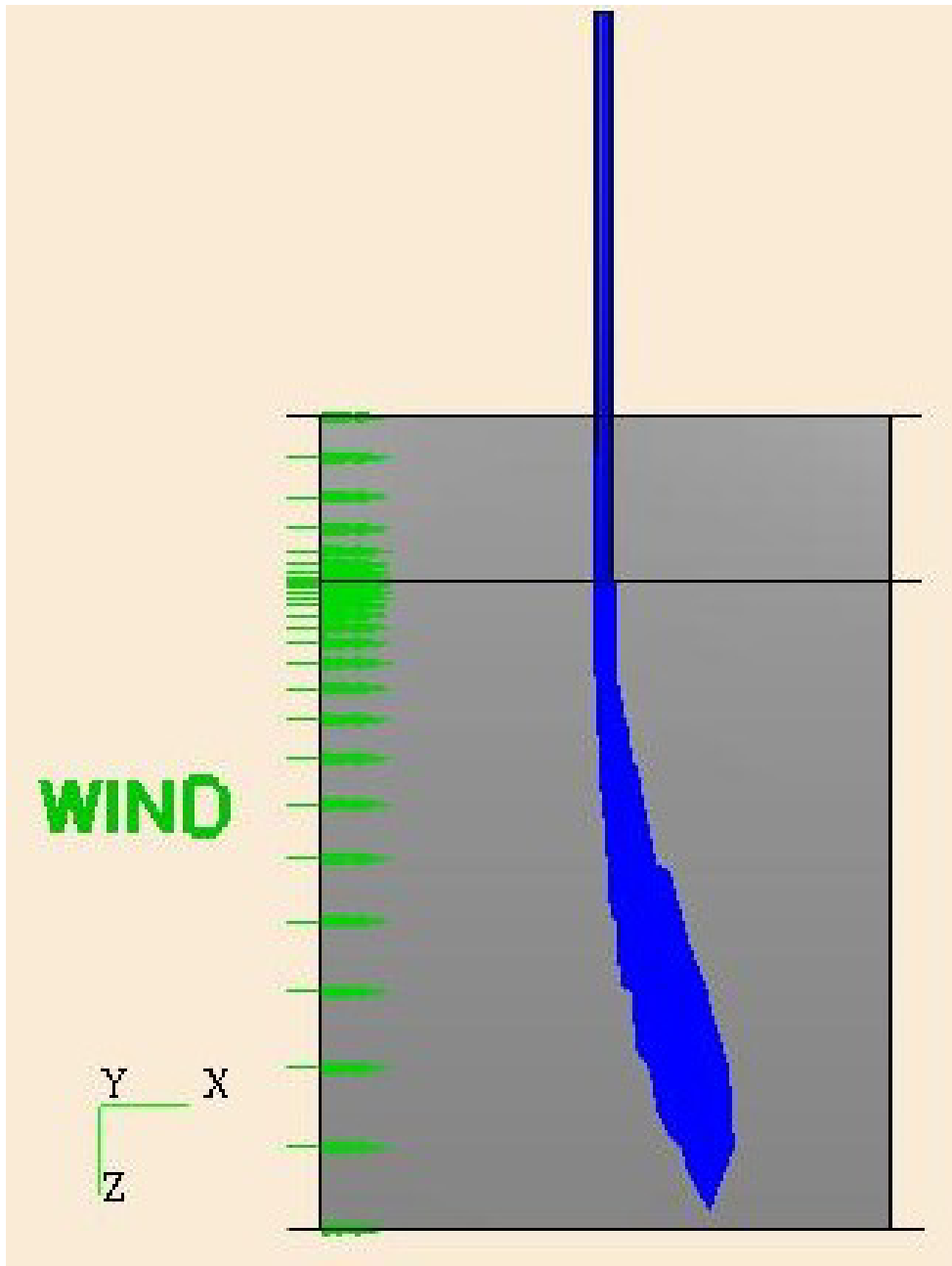

Figure 11. Plan View: Trial 1, 30 (kts).

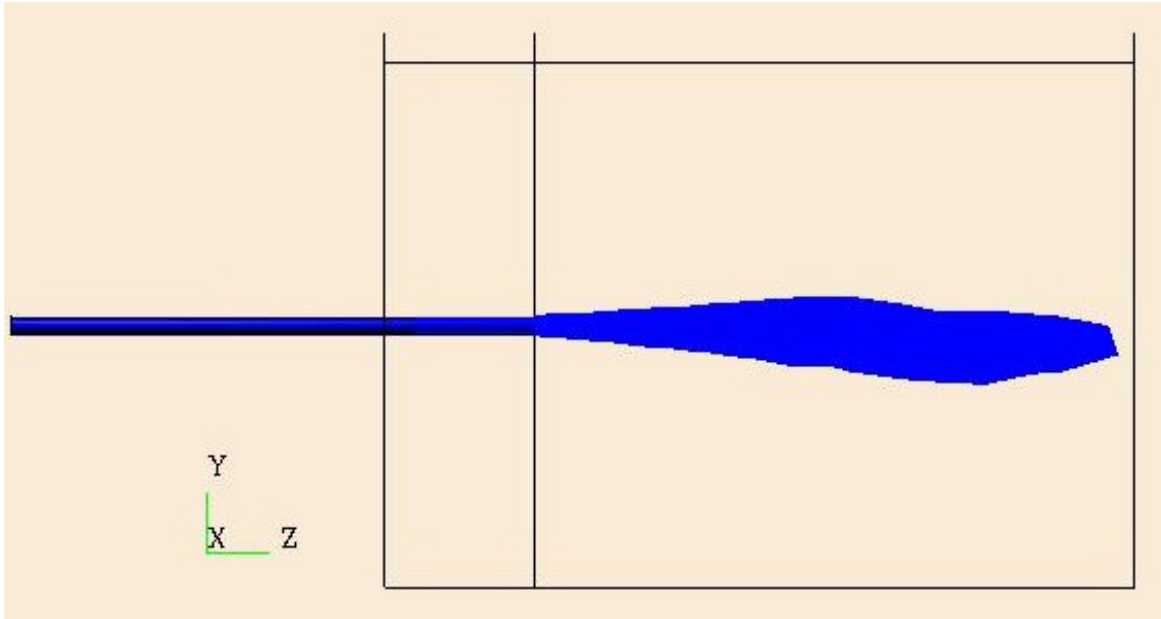

Figure 12. Side View: Trial 1, 30 (kts).

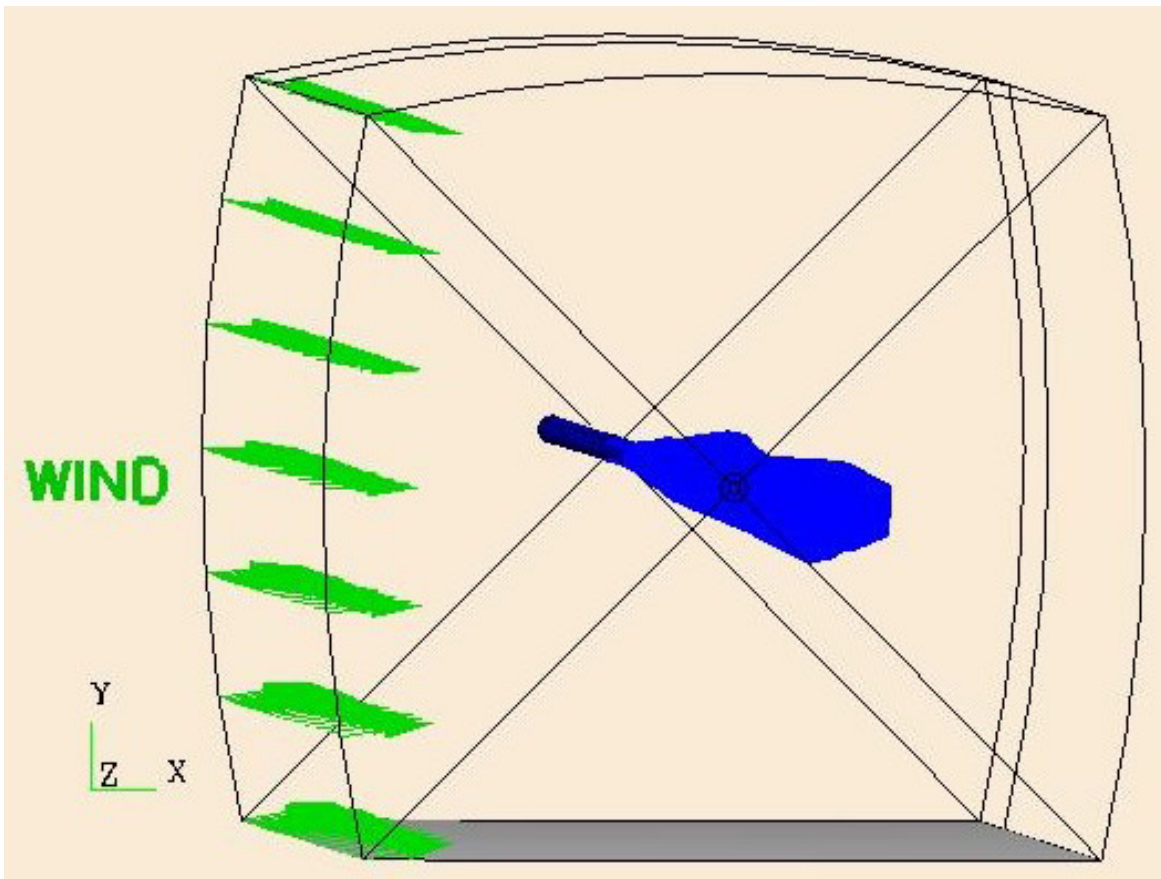

Figure 13. Angled View: Trial 1, 30 (kts).

Each of the flow rates 125 (GPM), 250 (GPM), and 500 (GPM) were tested exiting from 1 (in), 2 (in), and 3 (in) nozzles with cross winds of 15 (kts) and 30 (kts). The images displaying the resulting jet stream deflection due to the wind effects for the remaining trials are located in appendices C through J. They are summarized in Table 2.

Appendix	Trial	Flow Rate (GPM)	Wind Speed (kts)	Nozzle Size (in)
C	2	125	15, 30	2
D	3	125	15, 30	3
E	4	250	15, 30	1
F	5	250	15, 30	2
G	6	250	15, 30	3
H	7	500	15, 30	1
I	8	500	15, 30	2
J	9	500	15, 30	3

Table 2. Summary of Trials.

As is to be expected greater deflection and wind effects can be seen in the tests with higher wind speeds and larger flow rates.

IV. CONCLUSIONS

The results from this study display the wind effects on stream deflection at the fire hose nozzle exit. Field-testing needs to be performed to validate the model results.

The modeling performed in this study is computationally intensive and each trial took from two to three days to evaluate the mean stream deflection near the nozzle exit. Prediction of flow patterns and the available volume of fire fighting agent at the end of the stream would require expanding the model volume. Obtaining more detailed spray patterns would require a finer mesh within the volume. Both expanding the model volume and creating a finer mesh within the present model would significantly increase the time and RAM necessary to obtain valid results.

Based on the results of this study, computational fluid dynamics is an effective method of determining wind effects on a fire hose stream.

THIS PAGE INTENTIONALLY LEFT BLANK

V. RECOMMENDATIONS

The following recommendations are made in continuation of this study:

- Develop a model with a larger volume to obtain the results of full stream flow and reach.
- Estimate the volume of fluid available at the end of the stream.
- Model fluids of different densities such as AFFF, which are used for firefighting.
- Model the effects of various wind angles upon the fire hose stream.
- Vary the angle of the nozzle exit into the wind to possibly reduce wind effects.
- Develop a model with a finer mesh to resolve more detailed flow patterns such as spray and atomization.

The resulting information from the continuation of this study will assist engineers and ship designers to predict the best location for fire hose nozzles and the best techniques for reducing wind effects when combating fires.

THIS PAGE INTENTIONALLY LEFT BLANK

LIST OF REFERENCES

1. *NAVAL FORCES, Ship manpower: How low can we go?*, JANE'S DEFENCE WEEKLY, 2000 Ed., Vol. 033, Iss. 015, 12APR2000.
2. *Fire Suppression Substitutes and Alternatives to Halon for U.S. Navy Applications*, Naval Studies Board, Naval Research Council, National Academy Press, Washington, D.C 1997.
3. Breslin, D.A., *A History of the Navy's Strategic Reserve of Ozone-Depleting Substances*, Naval Engineers Journal, Vol. 200, p. 69-76, July 1999.
4. Toms, G.S, Breslin, D.A., Brunner, G.P., and Thill, J.C., *Navy's CFC & Halon Elimination Program*, Naval Engineers Journal, Vol. 112, No. 1, p. 91-112, January 2000.
5. *Halon 1301 Replacements*, http://p2library.nfesc.navy.mil/P2_Opportunity_Handbook/3_III_2.html, 9 June 2004
6. Floden, John R. (USAF), and Tapscott, Robert E., *Quest for Chemical Alternatives to Halon 1211*, Military Engineer, Vol. 82, No. 537, p. 13-15, August 1990.
7. Lentati, A.M., and Chelliah, H.K., *Dynamics of Water Droplets in a Counterflow Field and their Effect on Flame Extinction*, Combustion and Flame 115, p. 158-179, 1998.
8. *Water Mist: The most Effective Firefighting Solution?*, Naval Architect, p. 20, February 1996
9. Carhart, H.W., Leonard, J.T., Darwin, R.L., Burns, R.E., Hughes, J.T., and Jablonski, E.J., *Aircraft Carrier Flight Deck Fire Fighting Tactics and Equipment Evaluation Tests*, NRL Memorandum Report 5952, Naval Research Laboratory, Washington, D.C., 26 February 1987.

10. Leonard, J.T., Darwin, R.L., Burns, R.E., Beller, R.C., and Jablonski, E.J., *Preliminary Evaluation of the performance of Remote Controlled Firefighting Platforms in Combating Flight Deck Fires*, NRL Memorandum Report 6180-01-8549, Naval Research Laboratory, Washington, D.C., 23 April 2001.
11. CFD-ACE(U), User Manual, Version 2003, CFD Research Corporation, January 2003.

BIBLIOGRAPHY

- Alvarez, J., Jones, W.P., and Seoud, R., Predictions of Momentum and Scalar Fields in a Jet in a Cross-Flow using First and Second Order Turbulence Closures, AGARD Conference Proceedings 534, 24, November 1993.
- Breslin, D.A., A History of the Navy's Strategic Reserve of Ozone-Depleting Substances, Naval Engineers Journal, Vol. 200, p. 69-76, July 1999.
- Breslin, D.A., History of the Navy's Strategic Reserve of Ozone-Depleting Substances, Naval Engineers Journal, Vol. 111, No. 4, p. 69-76, July 1999.
- Breslin, D.A., Smith, D.E. and Toms, G.S. Sizing the Navy's Strategic Reserve of Ozone-Depleting Substances, Naval Engineers Journal, Vol. 112, No. 6, p. 17-25, November 2000.
- Carhart, H.W., Leonard, J.T., Darwin, R.L., Burns, R.E., Hughes, J.T., and Jablonski, E.J., Aircraft Carrier Flight Deck Fire Fighting Tactics and Equipment Evaluation Tests, NRL Memorandum Report 5952, Naval Research Laboratory, Washington, D.C., 26 February 1987.
- Carhart, H.W., Leonard, J.T., Darwin, R.L., Burns, R.E., Hughes, T.J., and Jablonski, E.J., Aircraft Carrier flight Deck Firefighting Tactics and Equipment Evaluation Tests: Executive Summary, NRL Memorandum Report 5751, Naval Research Laboratory, Washington, D.C., 25 March 1986.
- CFD-ACE(U), User Manual, Version 2003, CFD Research Corporation, January 2003.
- Chiu, S.H., Roth, K.R., Margason, R.J. and Tso, J., A Numerical Investigation of a Subsonic Jet in a Crossflow, AGARD Conference Proceedings 534, 22, November 1993.
- Coelho, Sergio L.V. and Hunt, J.C.R., The Dynamics of the Near Field of Strong Jets in Crossflows, Journal of Fluid Mechanics, Vol. 200, p. 95-120, March 1989.

Darwin, Robert L., Scheffey, Joseph L., Bowman, Howard L., and Williams, Frederick W., Requirements for an Aircraft Carrier Flight Deck Fire Fighting Test Facility, NRL Memorandum Report 6180-03-8668, Naval Research Laboratory, Washington, D.C., 20 February 2003.

Farman, G.J., Modeling of Shipboard Smoke Propagation with a Forced Counter-Flow Air Supply, Master's Thesis, Naval Postgraduate School, Monterey, California, June 2001.

Farooq, M., Balachandar, R., Wulfsohn, D. and Wolf, T.M., Agricultural Sprays in Cross-flow and Drift, *J. Agricultural Engineering Research*, 78(4), 347-358, 2001.

Fire Suppression Substitutes and Alternatives to Halon for U.S. Navy Applications, Naval Studies Board, Naval Research Council, National Academy Press, Washington, D.C 1997.

Floden, John R. (USAF), and Tapscott, Robert E., Quest for Chemical Alternatives to Halon 1211, *Military Engineer*, Vol. 82, No. 537, p. 13-15, August 1990.

Ghosh, S., and Hunt, J.C.R., Spray Jets in a Cross-flow, *Journal of Fluid Mechanics*, Vol. 365, p. 109-136, 25 June 1998.

Halon 1301 Replacements,

http://p2library.nfesc.navy.mil/P2_Opportunity_Handbook/3_I_II_2.html, 9 June 2004

Hirt, C.W. and Nichols, B.D., Volume of Fluid (VOF) Method for the Dynamics of Free Boundaries, *Journal of Computational Physics*, Vol. 39, p. 201-225, 1981.

Ince, N.Z., Leschziner, M.A., Calculation of Single and Multiple Jets in Cross-Flow with and without Impingement using Reynolds-Stress-Transport Closure, AGARD Conference Proceedings 534, 23, November 1993.

Kavsaoglu, M.S., Akmandor, I.S., Ciray, S. and Fujii, K., Navier-Stokes Simulation of Two and Three Dimensional Jets in Crossflow, Effects of Grid and Boundary Conditions, AGARD Conference Proceedings 534, 25, November 1993.

Kelso, R.M., Lim, T.T., and Perry, A.E., An Experimental Study of round Jets in Cross-flow, *Journal of Fluid Mechanics*, Vol. 306, p. 111-144, 10 January 1996.

Lentati, A.M., and Chelliah, H.K., Dynamics of Water Droplets in a Counterflow Field and their Effect on Flame Extinction, Combustion and Flame 115, p. 158-179, 1998.

Leonard, J.T., Darwin, R.L., Burns, R.E., Beller, R.C., and Jablonski, E.J., Preliminary Evaluation of the performance of Remote Controlled Firefighting Platforms in Combating Flight Deck Fires, NRL Memorandum Report 6180-01-8549, Naval Research Laboratory, Washington, D.C., 23 April 2001.

Milanovic, Ivana M., and Zaman, K.B.M.Q., Fluid Dynamics of Highly Pitched and Yawed Jets in Crossflow, AIAA Journal, Vol. 42, No. 5, May 2004.

Moussa, Z.M., Trischka, John W., and Eskinazi, S., The Near Field in the mixing of a Round Jet with a Cross-stream, Journal of Fluid Mechanics, Vol. 80, p.49-80, 1977.

NAVAL FORCES, Ship manpower: How low can we go?, JANE'S DEFENCE WEEKLY, 2000 Ed., Vol. 033, Iss. 015, 12APR2000.

Sherman, Frederick S. Viscous Flow, McGraw-Hill Publishing Company, New York, 1990.

Smith, Dennis, Breslin, David A., Toms, Gregory S., and Norton, P., Monitoring the Navy's Strategic Reserve of Ozone-Depleting Substances, Naval Engineers Journal, Vol. 114, No. 4, p. 95-104, Fall 2002.

Toms, G.S, Breslin, D.A., Brunner, G.P., and Thill, J.C., Navy's CFC & Halon Elimination Program, Naval Engineers Journal, Vol. 112, No. 1, p. 91-112, January 2000.

Water Mist: The most Effective Firefighting Solution?, Naval Architect, p. 20, February 1996.

White, Frank M. Fluid Mechanics, McGraw-Hill Publishing Company, 5th Ed., New York, 2003.

THIS PAGE INTENTIONALLY LEFT BLANK

APPENDIX A. GRID FORMATION

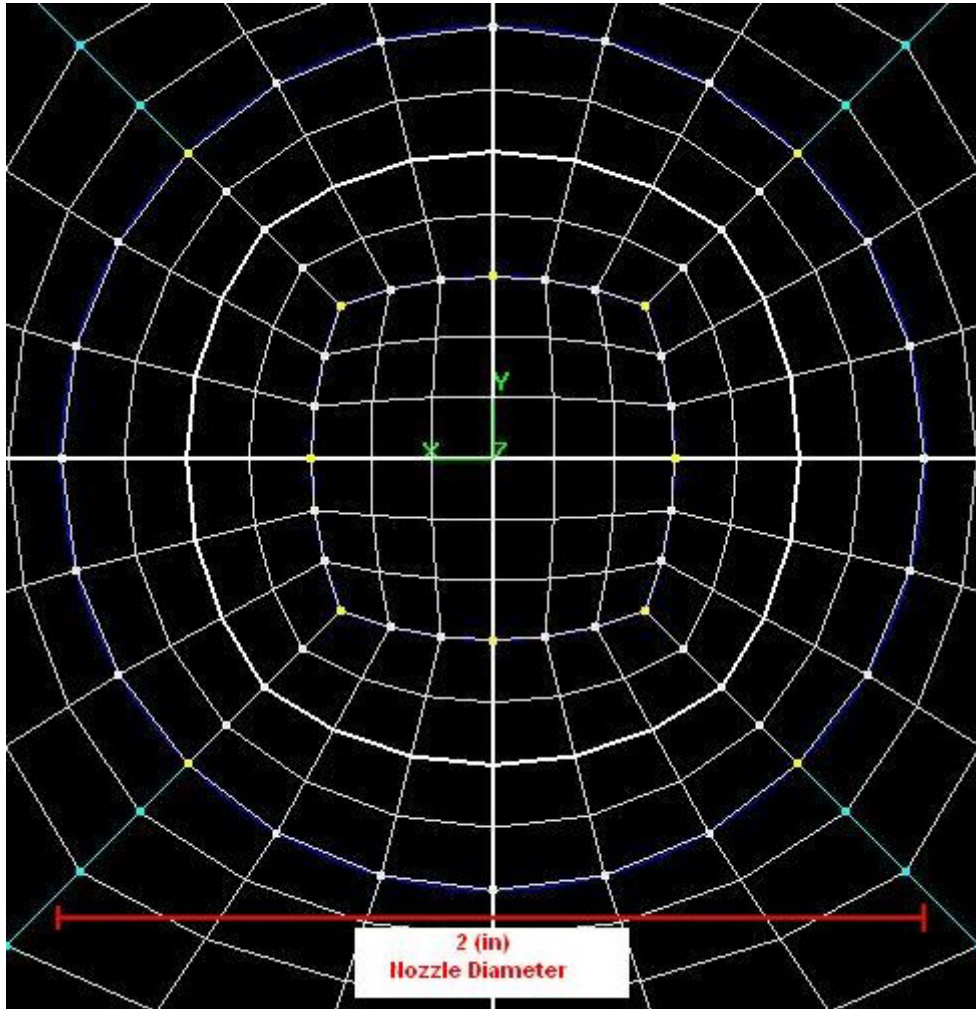

Figure 14. 2 (in) Nozzle Grid Spacing

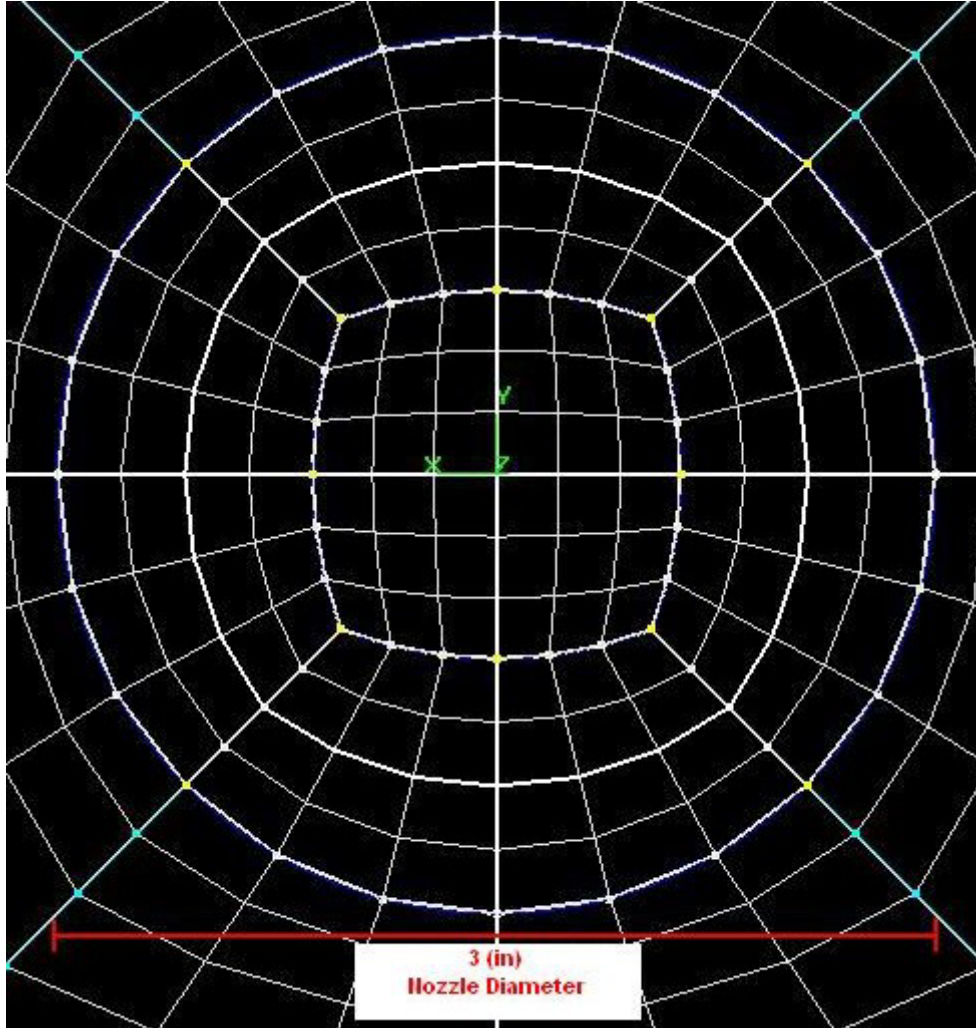

Figure 15. 3 (in) Nozzle Grid Spacing

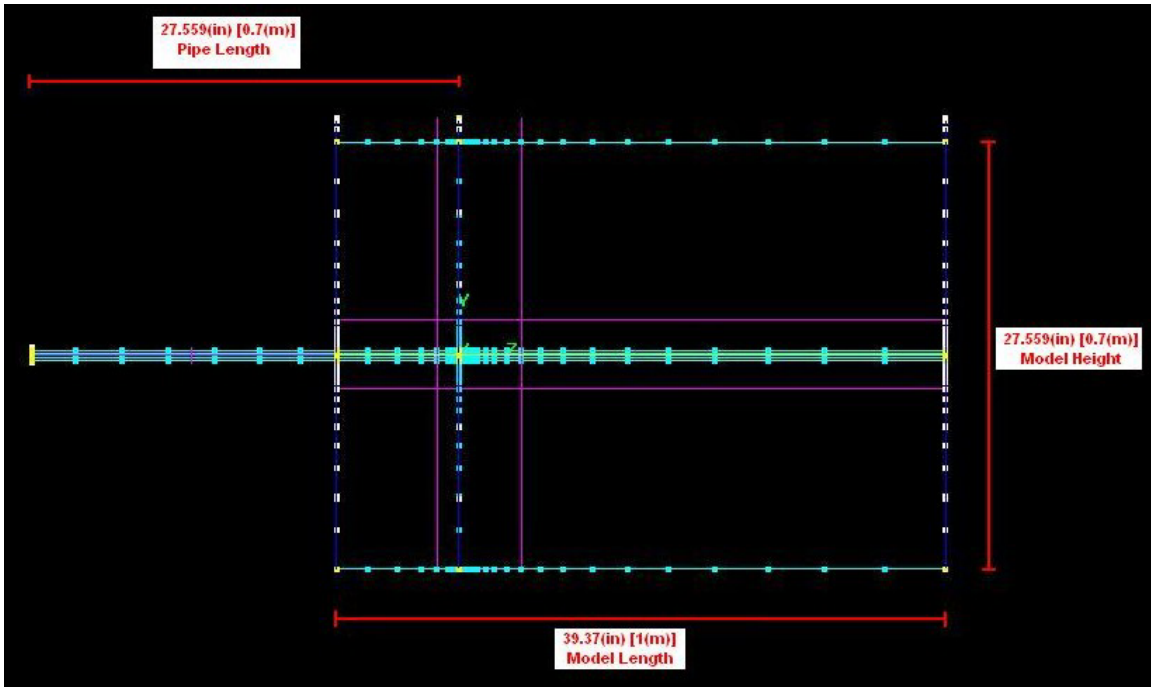

Figure 16. Side View without Grid

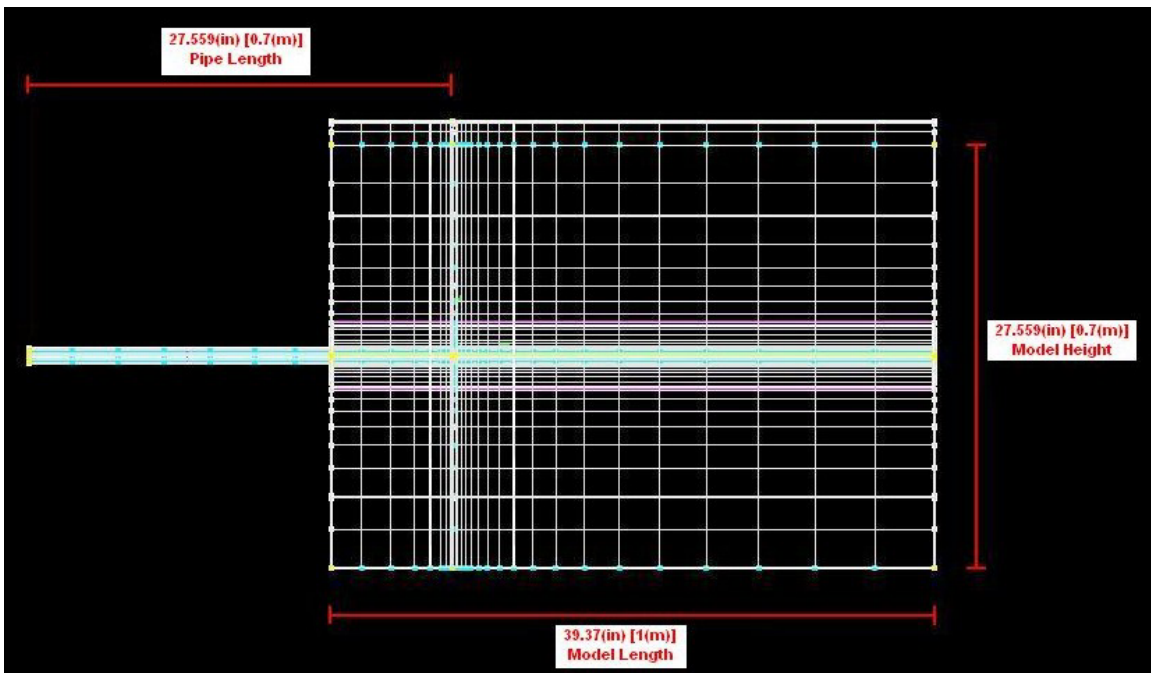

Figure 17. Side View with Grid

THIS PAGE INTENTIONALLY LEFT BLANK

APPENDIX B. SAMPLE INPUTS CFD-ACE (TRIAL 1)

PT: Modules->Flow, Free Surface (VOF)

MO: Shared->

Simulation Description->Title->Re=678041.2230

Transient Conditions->

Time Dependence: Transient

Transient Time Step: Auto Time Step, Start

Time:0, End Time:10, Target

Target CFL:0.2, Minimum dt:0, Maximum dt:1,

Initial dt:1E-6

Time Accuracy->Euler (1st Order)

Body Forces->Gravity->Gravity in Y-Direction:

Constant -9.81(m/s²)->Ref. Density: User

Specify 1.16(kg/m³)

Flow->Flow->Reference Pressure: 101325(N/m²)

VC: Group Fluid VCs->Activate Secondary Fluid

Phys->Density: Constant 1.1614(kg/m³)

Fluid->Viscosity: Constant(Dynamic) 1.846E-5(kg/m-s)

VOF->Name: Water, Density: Constant 1000(kg/m³),

Viscosity: Constant(Kinematic) 1E-6(m²/s)

BC: Group Outlet->BC Setting Mode->General

BC Type->Outlet

Flow->Flow->Subtype->Fixed Pressure

Group Pipe (Outside Volume)-> BC Setting Mode->General

BC Type->Wall

VOF->Fluid Volume Fraction->Fluid 1(Fraction=0)

Group Pipe(Protruding into Volume)->BC Setting
Mode->Thin Wall

BC Type->Thin Wall->Set

BC Setting Mode->General

Group Inlet Wind-> BC Setting Mode->General

BC Type->Inlet

Flow->Flow->Subtype->Fix Vel. (Normal)

Normal Velocity: Constant 7.716(m/s)

VOF->Fluid Volume Fraction->Fluid 1(Fraction=0)

Group Flight Deck->BC Setting Mode->General

BC Type->Wall

Group Inlet Water->BC Setting Mode->General

BC Type->Inlet

Flow->Flow->Subtype->Fix Vel. (Normal)

Normal Velocity: Constant 31.2804(m/s)

VOF->Fluid Volume Fraction->Fluid 2(Fraction=1)

IC: IC Option->Constant->IC Applied: Volume by Volume

Group Volume within Pipe->BC Setting Mode->General

VOF->VOF->All Fluid 1

SC: Iter->Shared->Max. Iterations: 50

Solvers->Velocity->CGS+Pre:Sweeps=50, Criterion=0.0001

P Correction->AMG:Sweeps=50, Criterion=0.1

Relax->Inertial Relaxation->Velocities: 0.2,
Linear Relaxation->Pressure: 0.9

Adv->VOF->Activate Remove Flotsam and Jetsam->Removal
Frequency: 1

OUT: Output->Output Frequency->Constant Time Step->Starting
Timestep: 0, Ending Timestep: 10000000,
Timestep Frequency: 20

Print->Activate Mass Flux Summary

THIS PAGE INTENTIONALLY LEFT BLANK

APPENDIX C. TRIAL 2

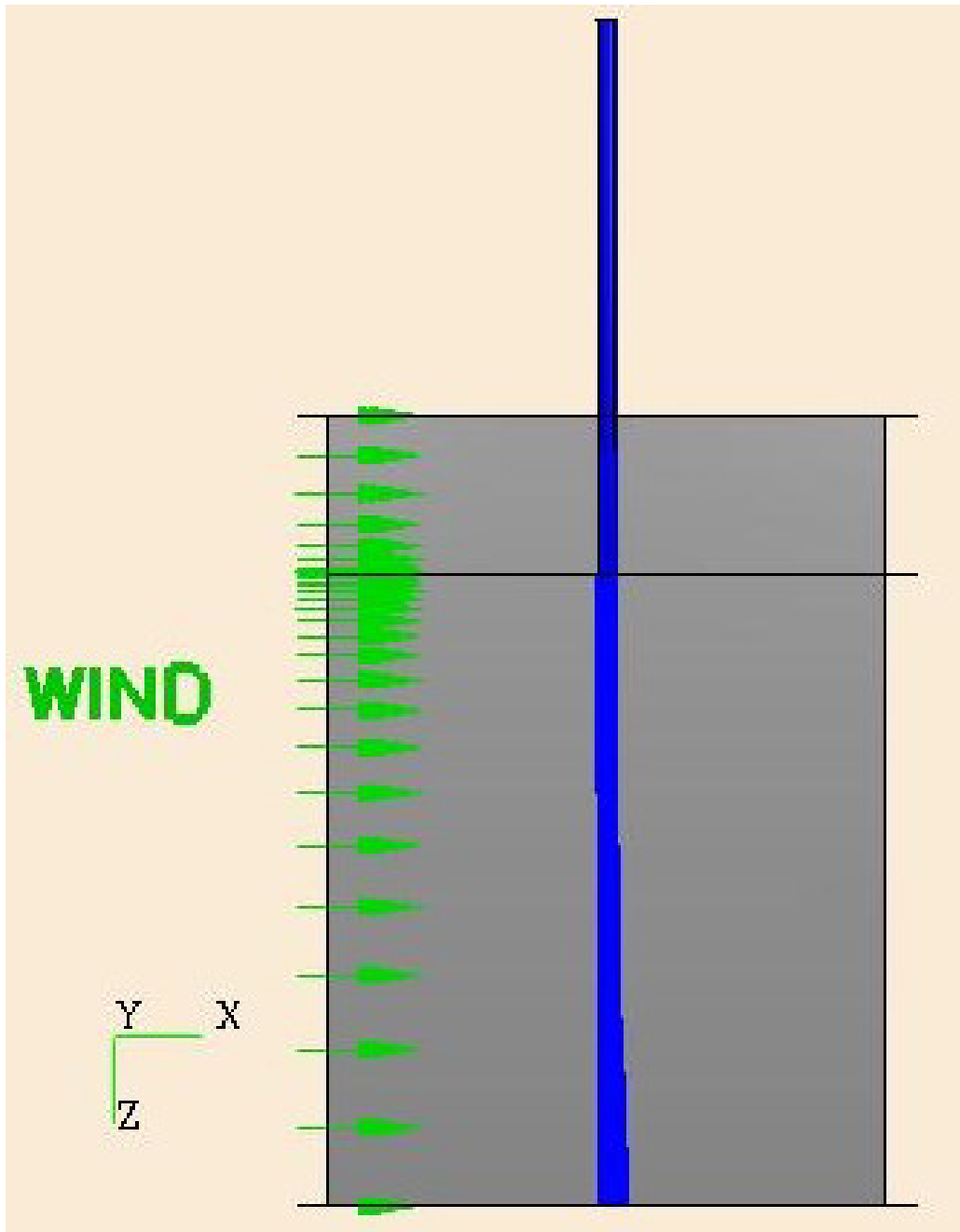

Figure 18. Plan View: Trial 2, 15 (kts).

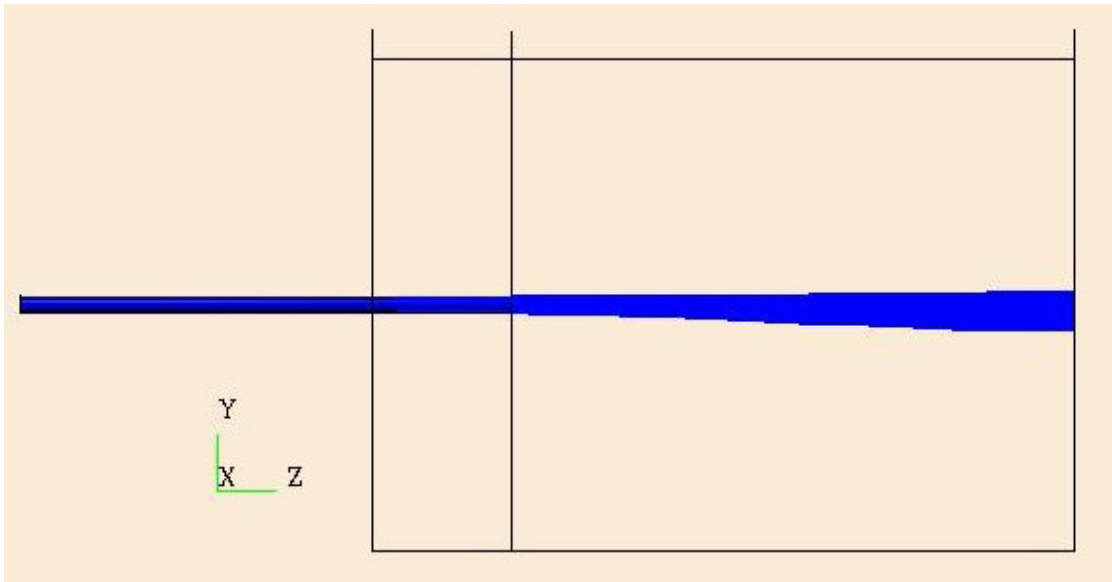

Figure 19. Side View: Trial 2, 15 (kts).

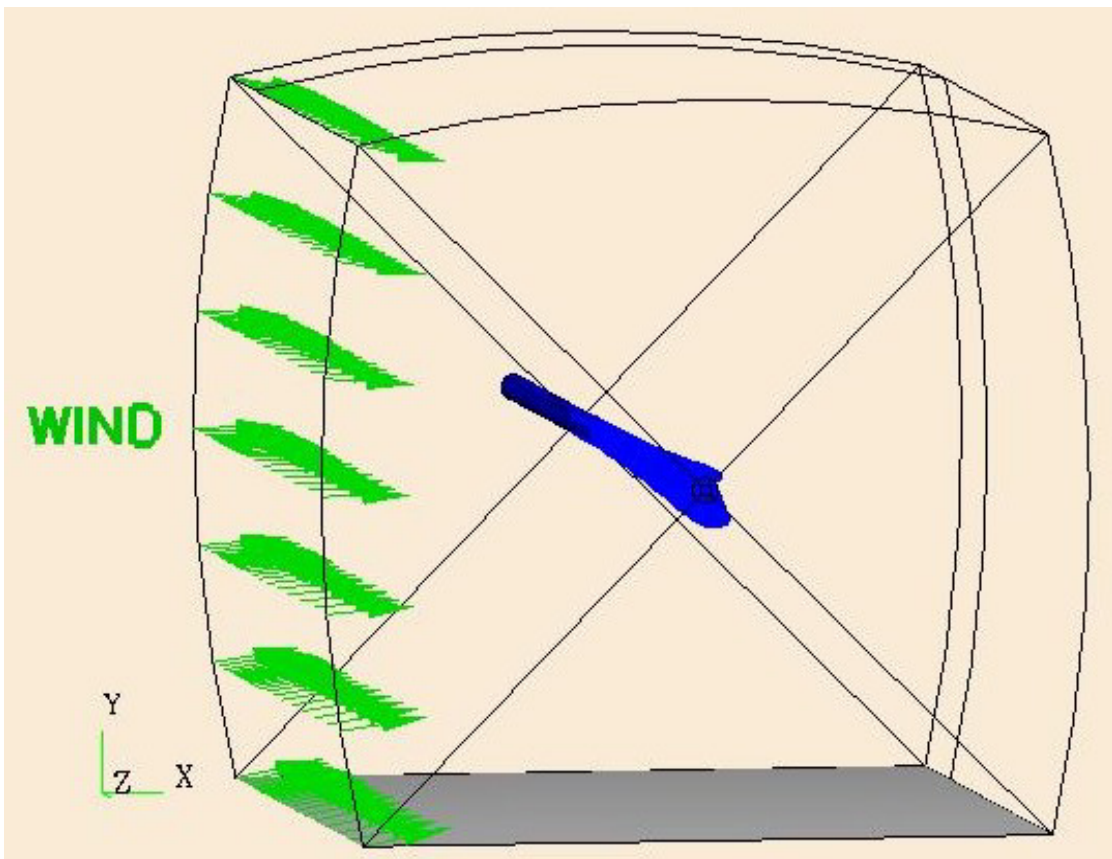

Figure 20. Angled View: Trial 2, 15 (kts).

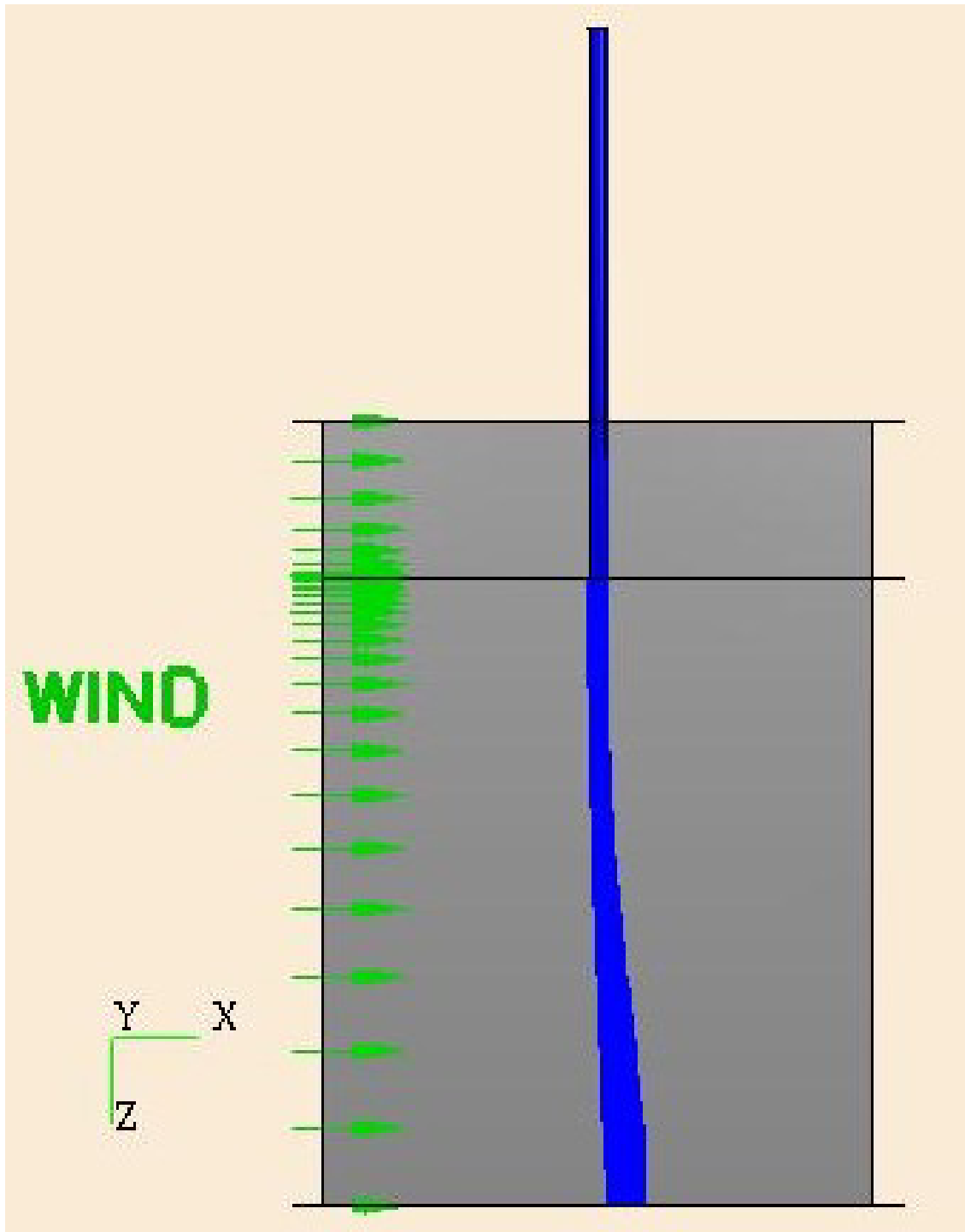

Figure 21. Plan View: Trial 2, 30 (kts).

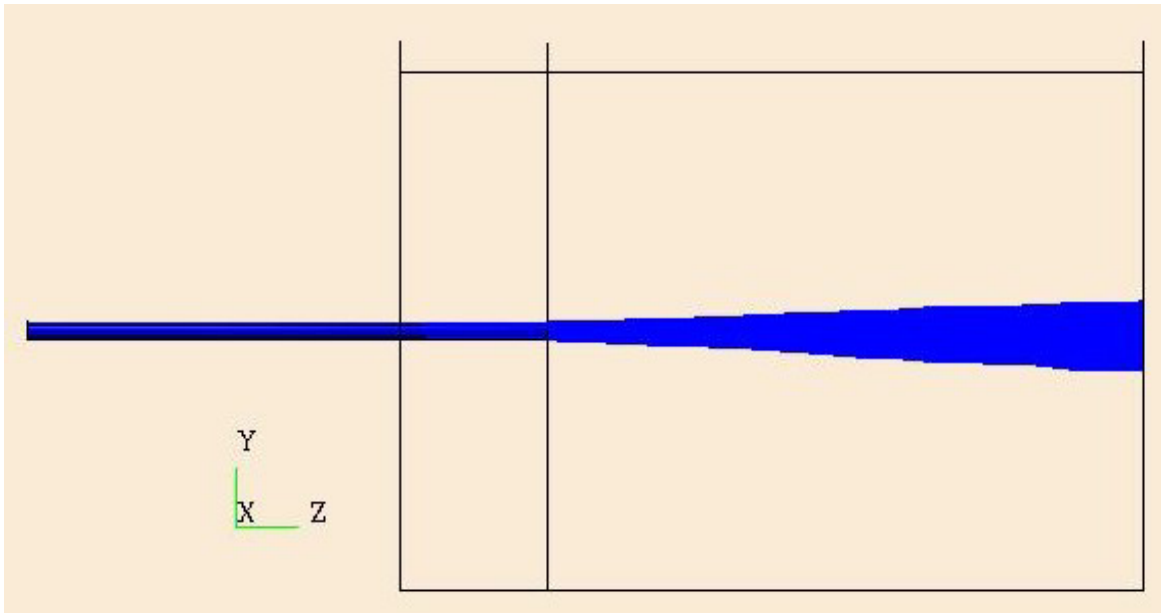

Figure 22. Side View: Trial 2, 30 (kts).

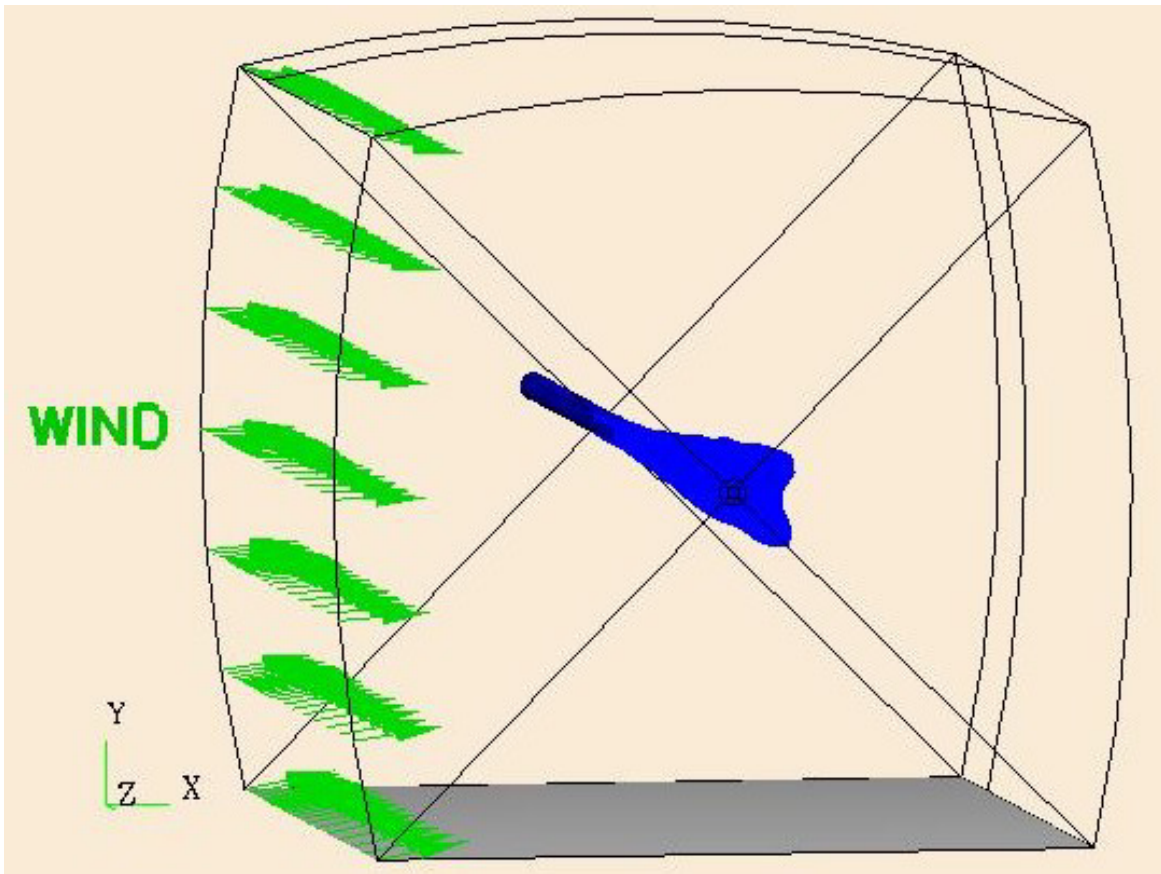

Figure 23. Angled View: Trial 2, 30 (kts).

APPENDIX D. TRIAL 3

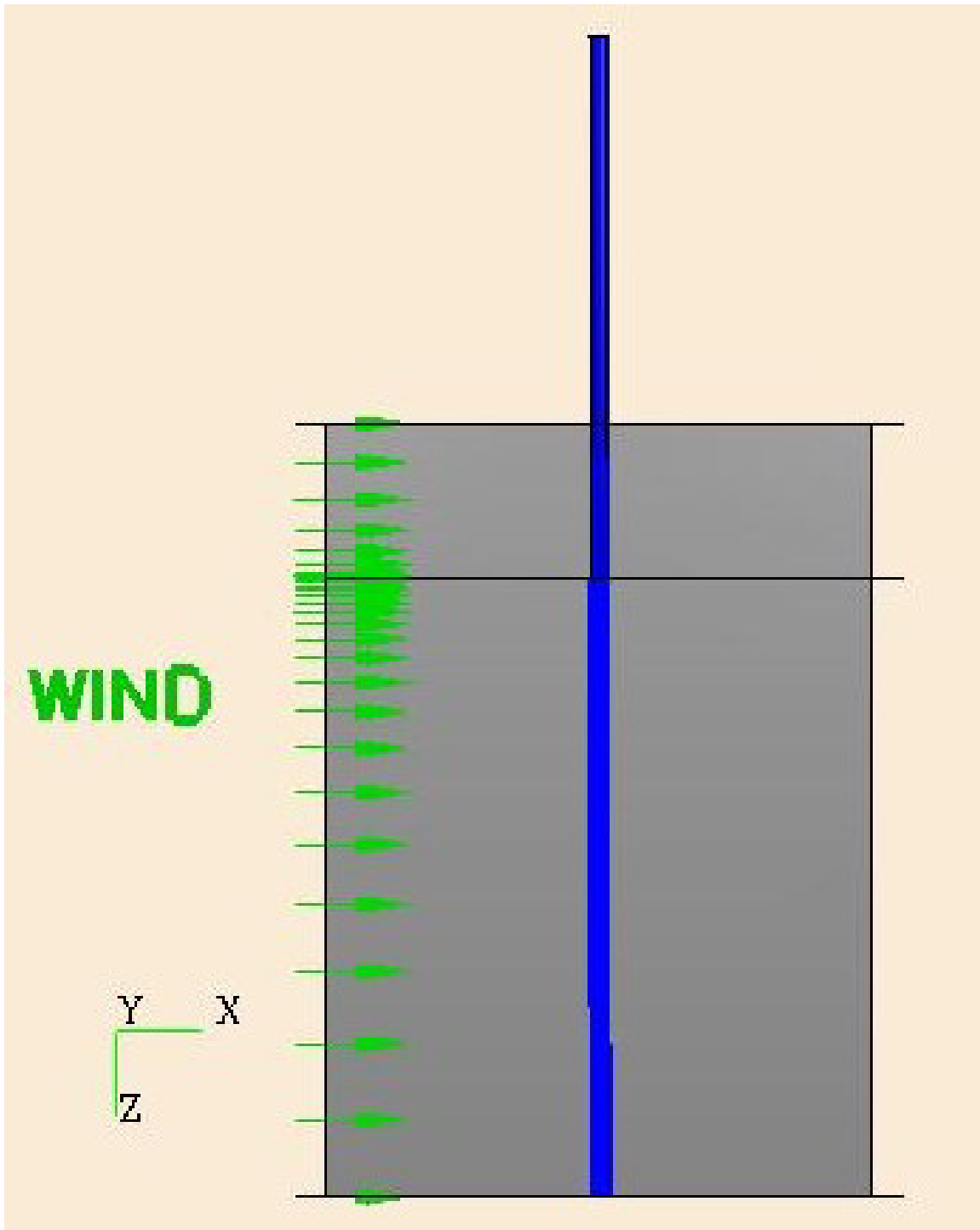

Figure 24. Plan View: Trial 3, 15 (kts).

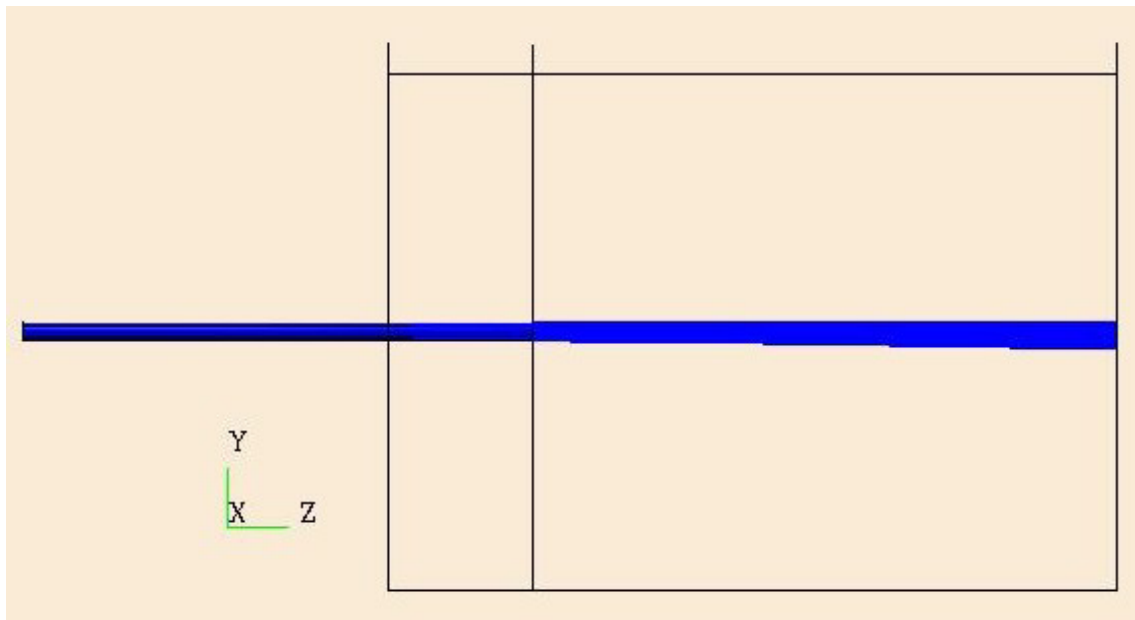

Figure 25. Side View: Trial 3, 15 (kts).

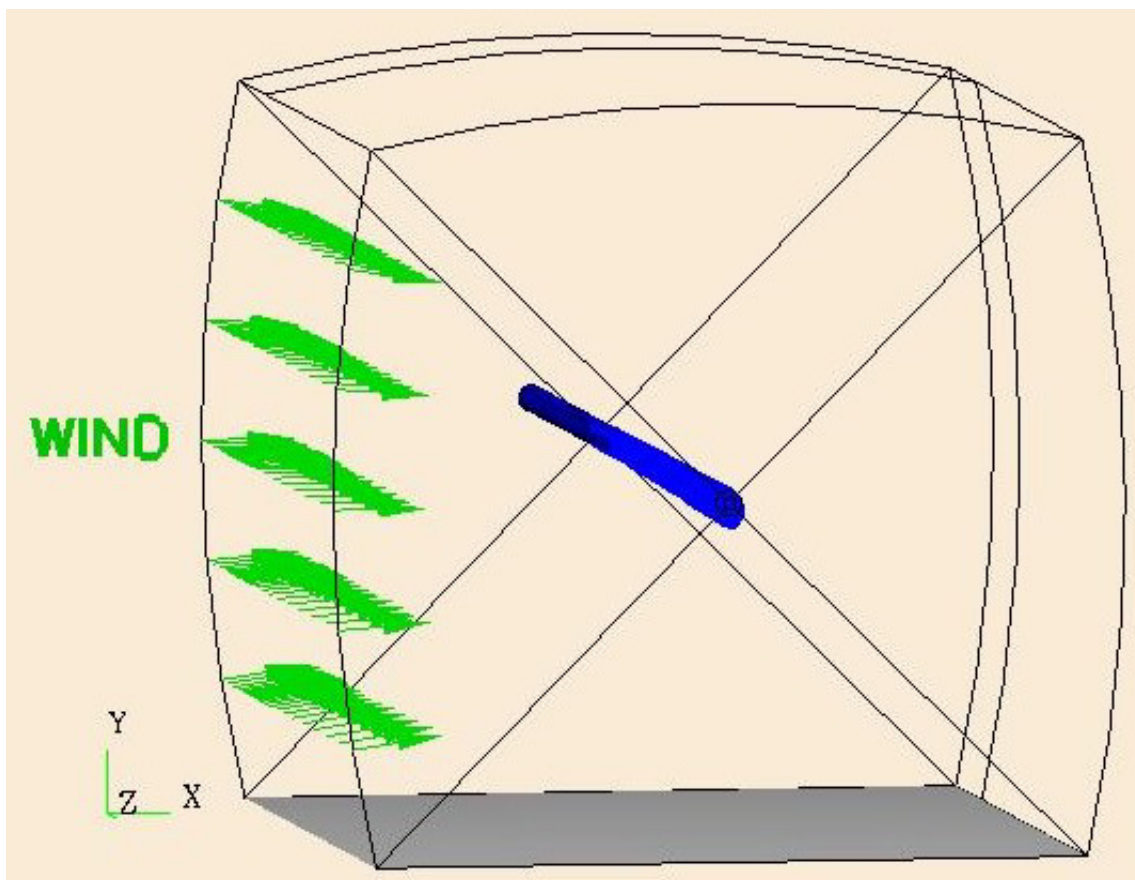

Figure 26. Angled View: Trial 3, 15 (kts).

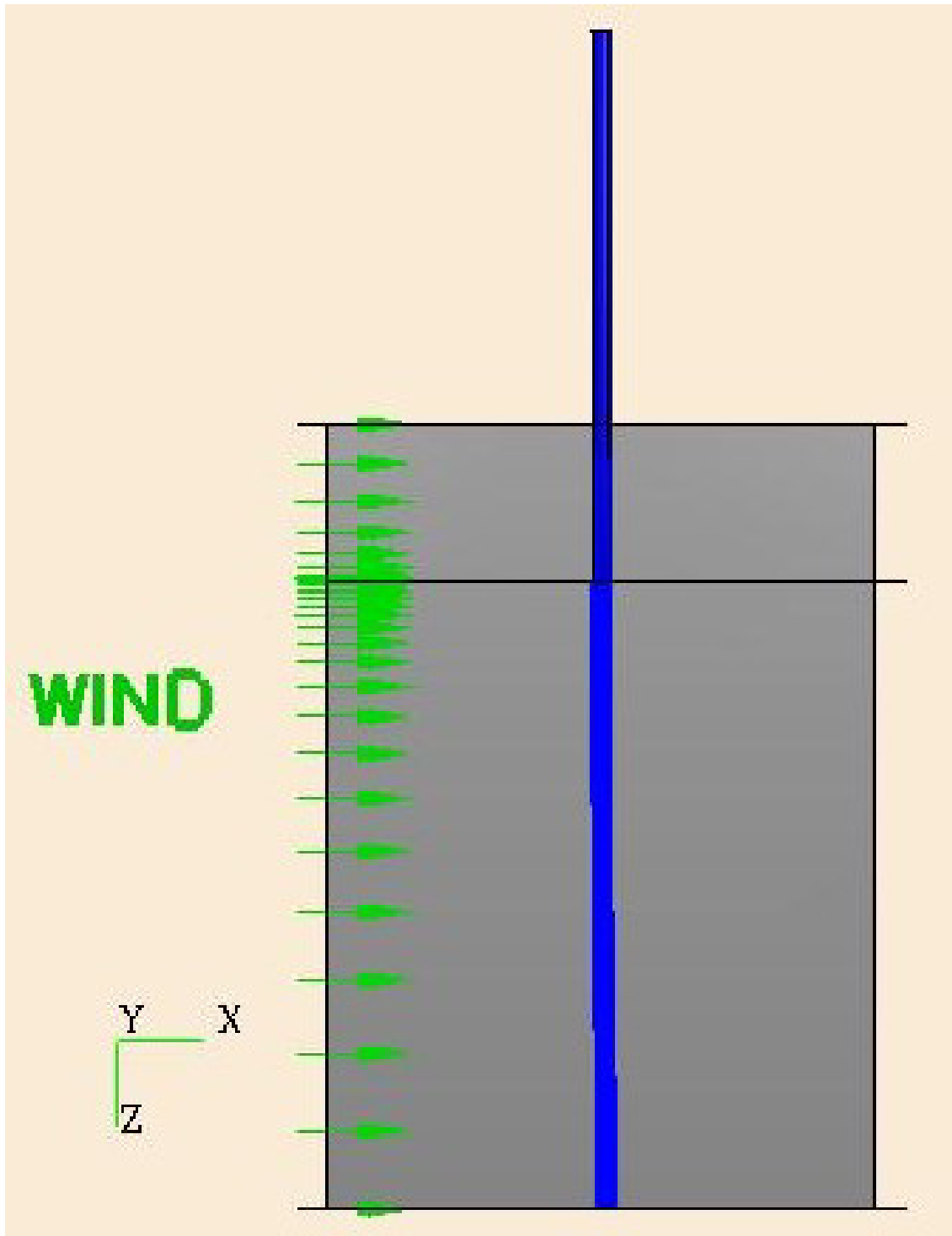

Figure 27. Plan View: Trial 3, 30 (kts).

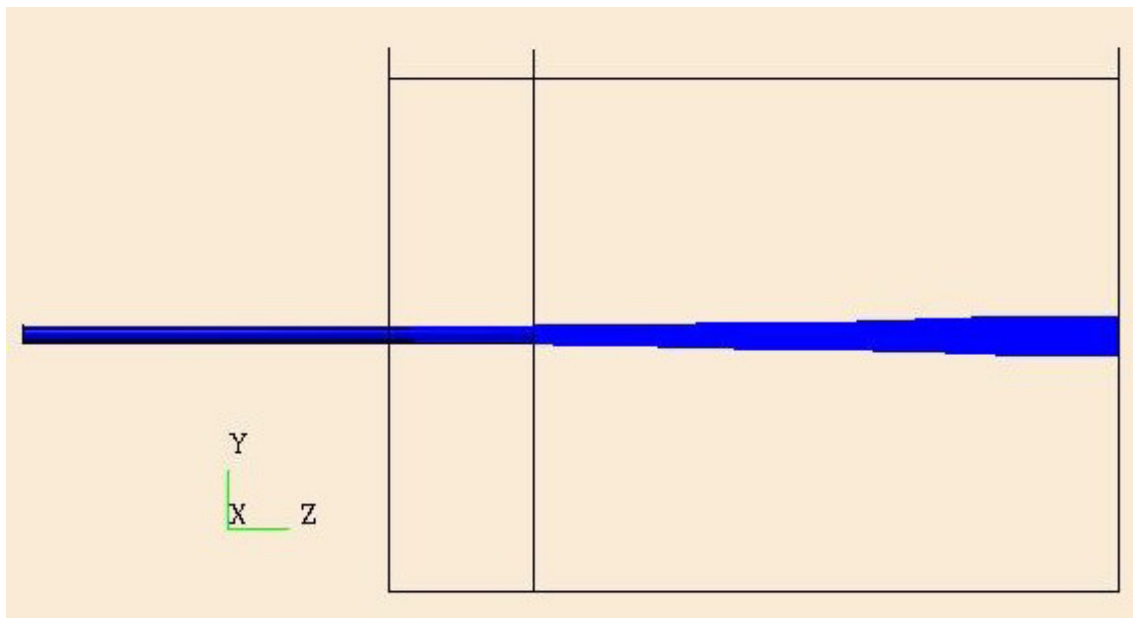

Figure 28. Side View: Trial 3, 30 (kts).

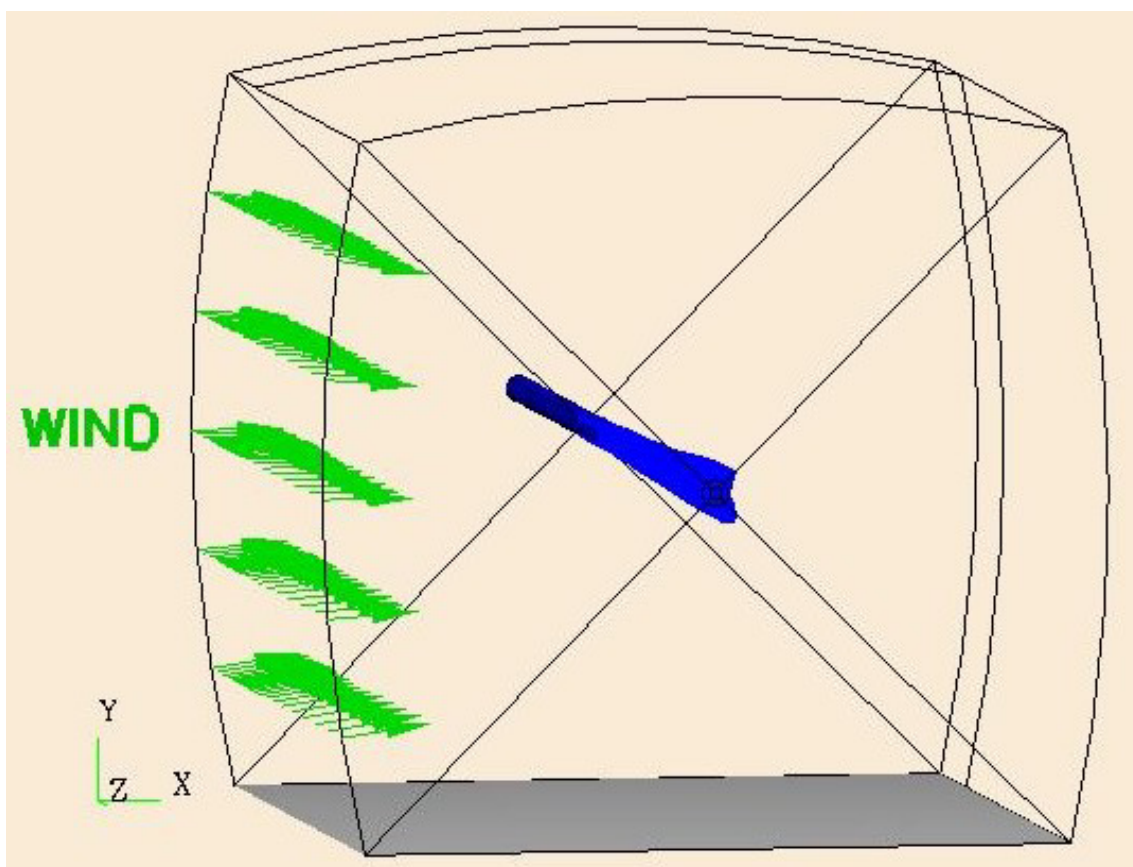

Figure 29. Angled View: Trial 3, 30 (kts).

APPENDIX E. TRIAL 4

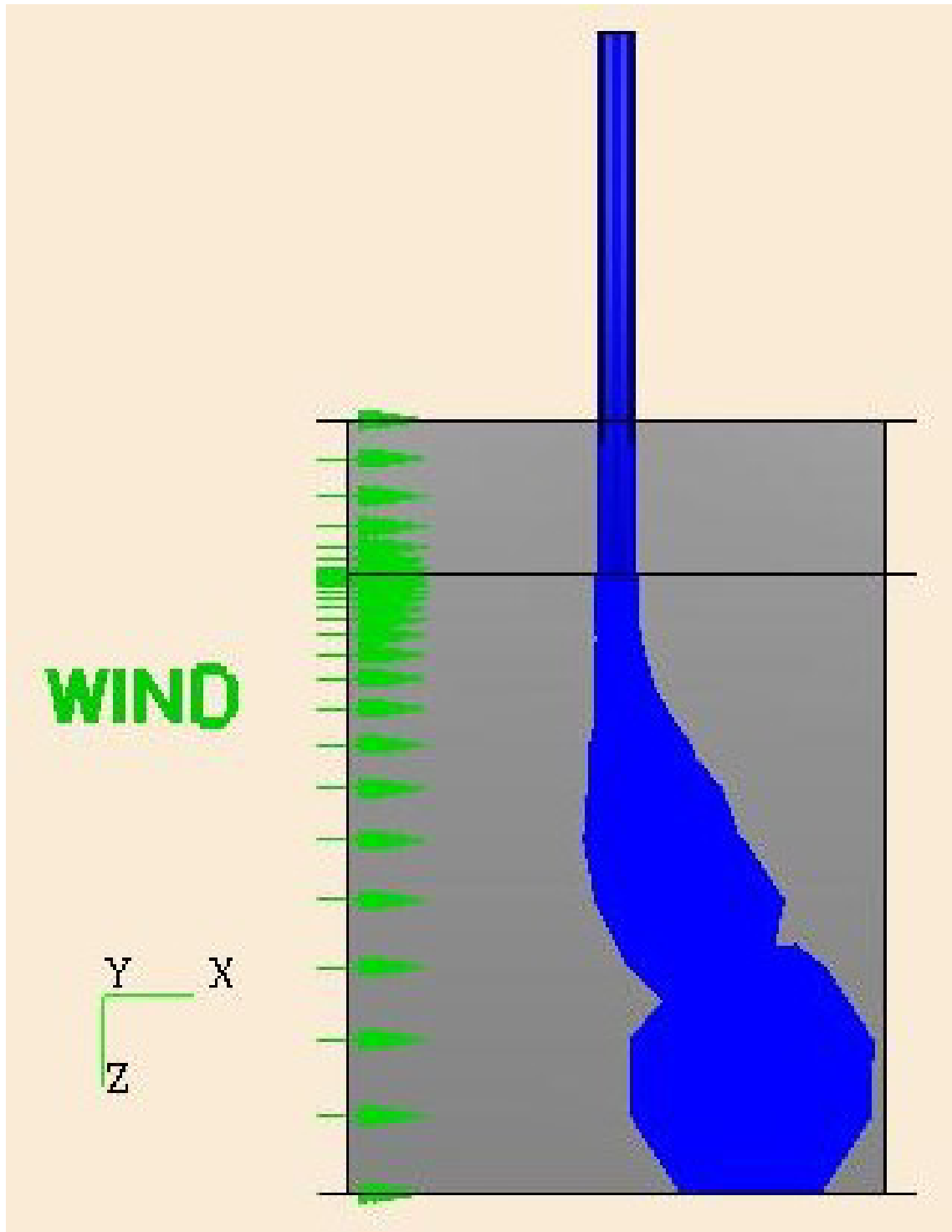

Figure 30. Plan View: Trial 4, 15 (kts).

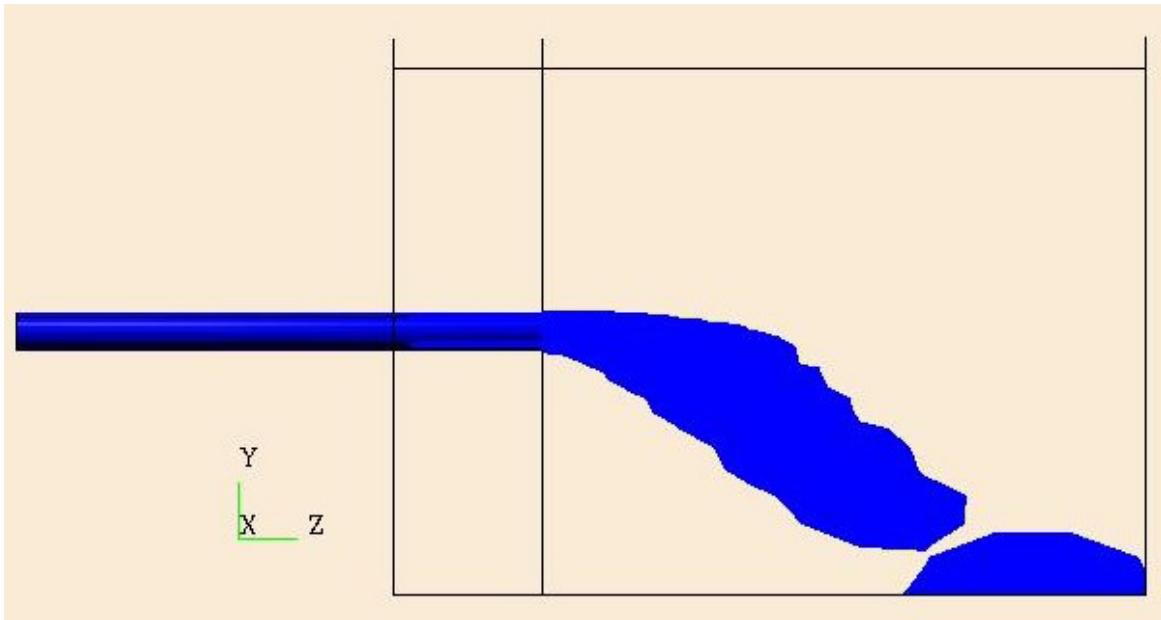

Figure 31. Side View: Trial 4, 15 (kts).

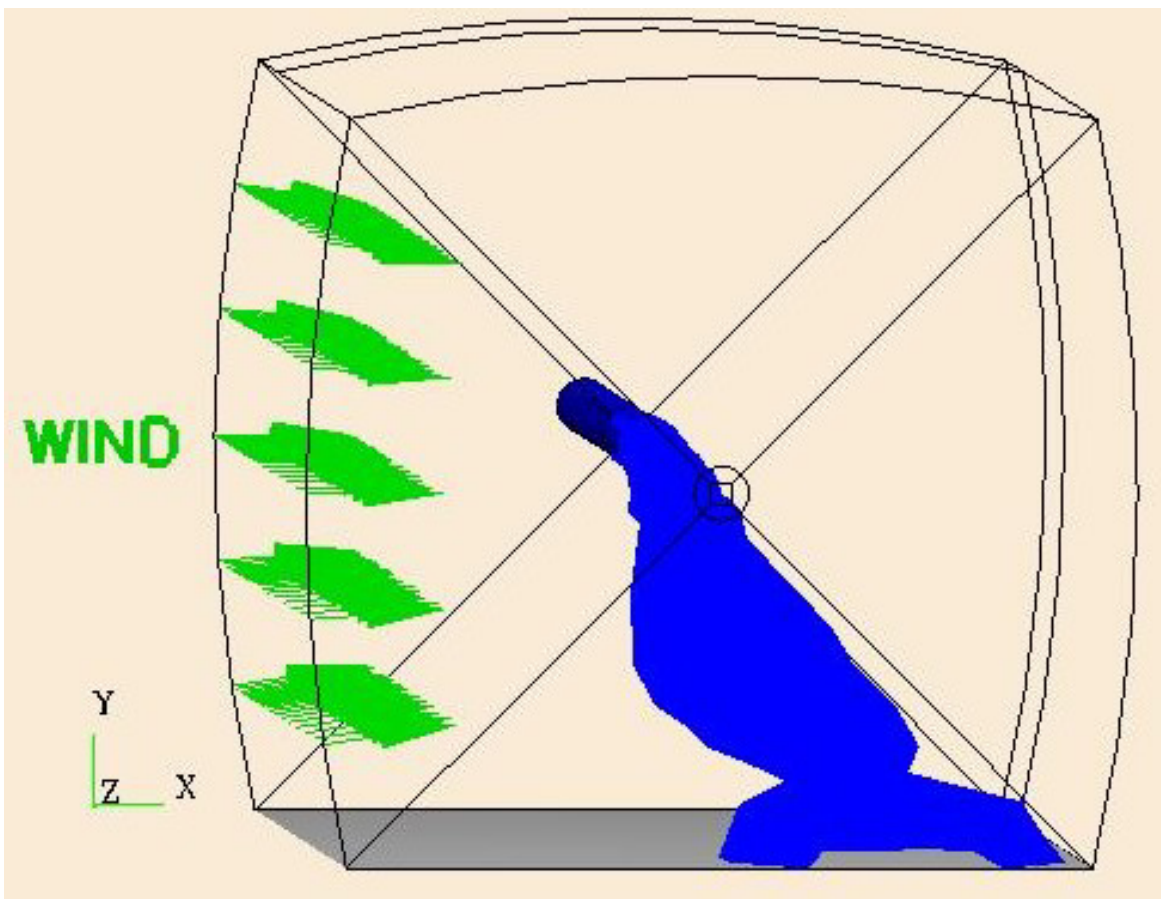

Figure 32. Angled View: Trial 4, 15 (kts).

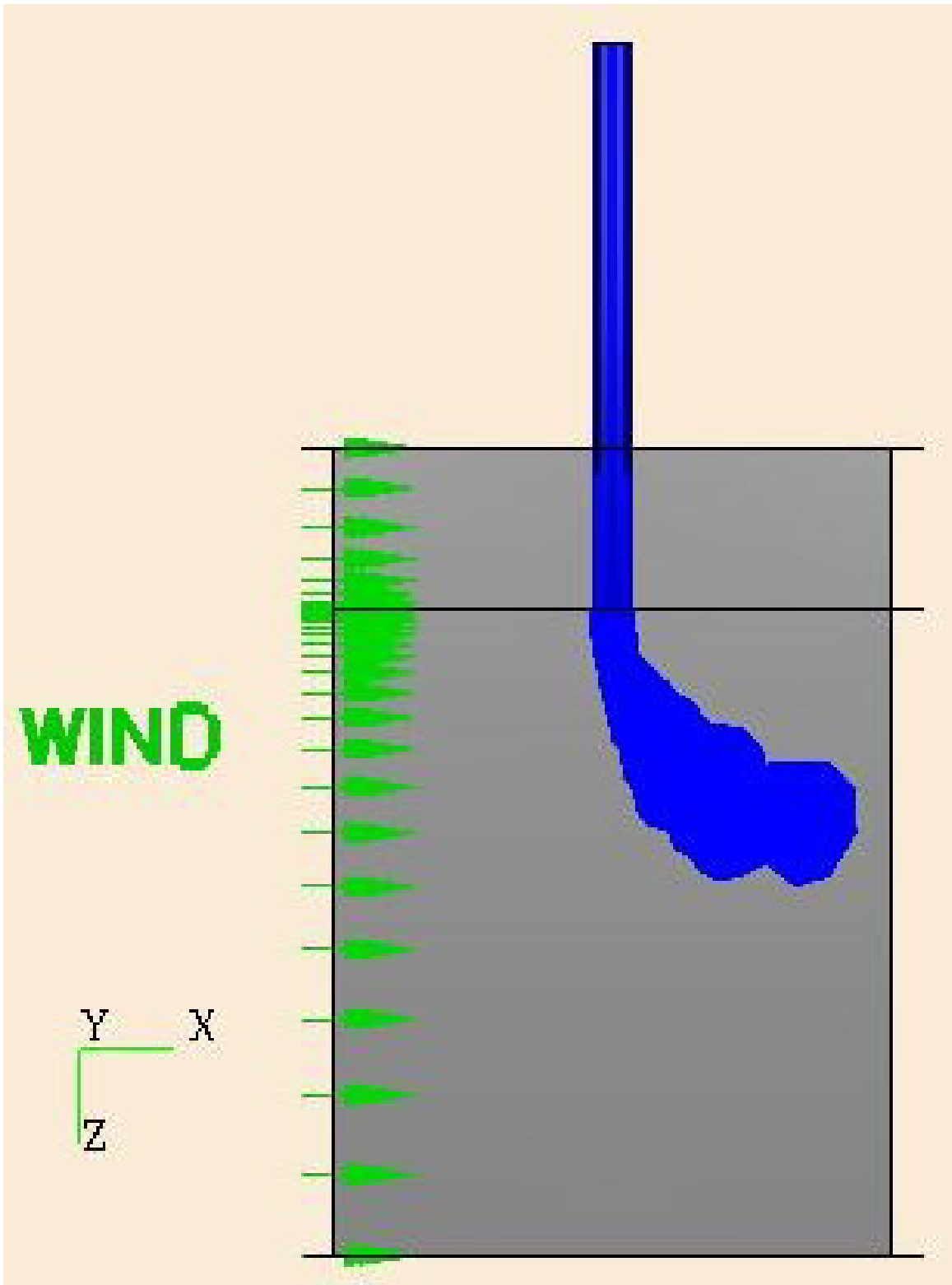

Figure 33. Plan View: Trial 4, 30 (kts).

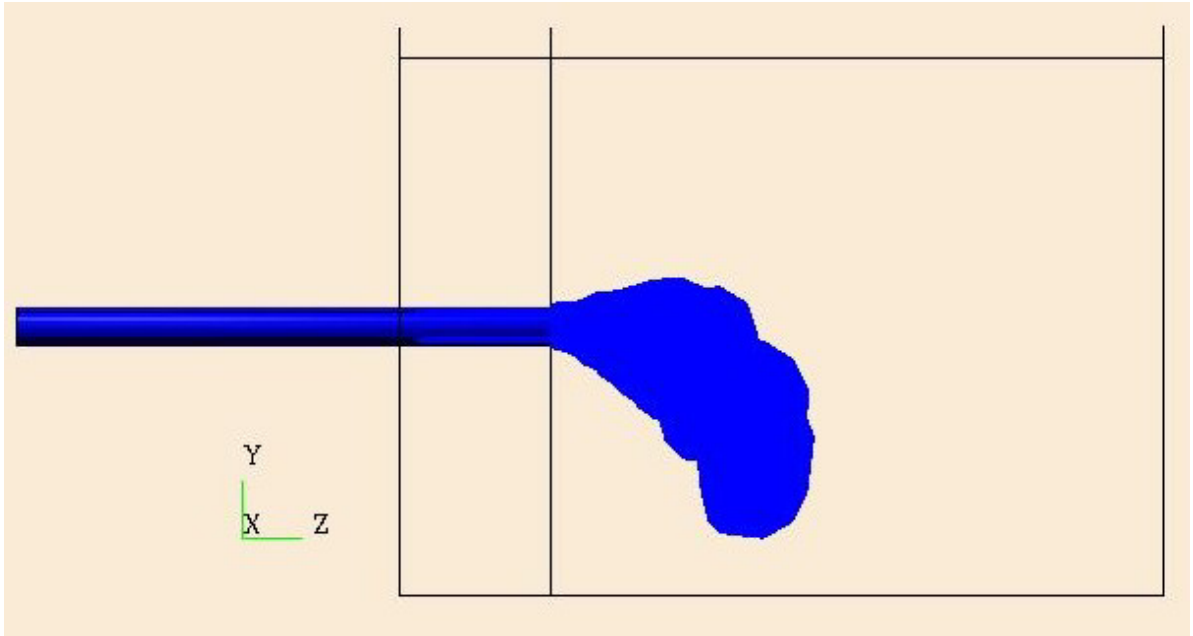

Figure 34. Side View: Trial 4, 30 (kts).

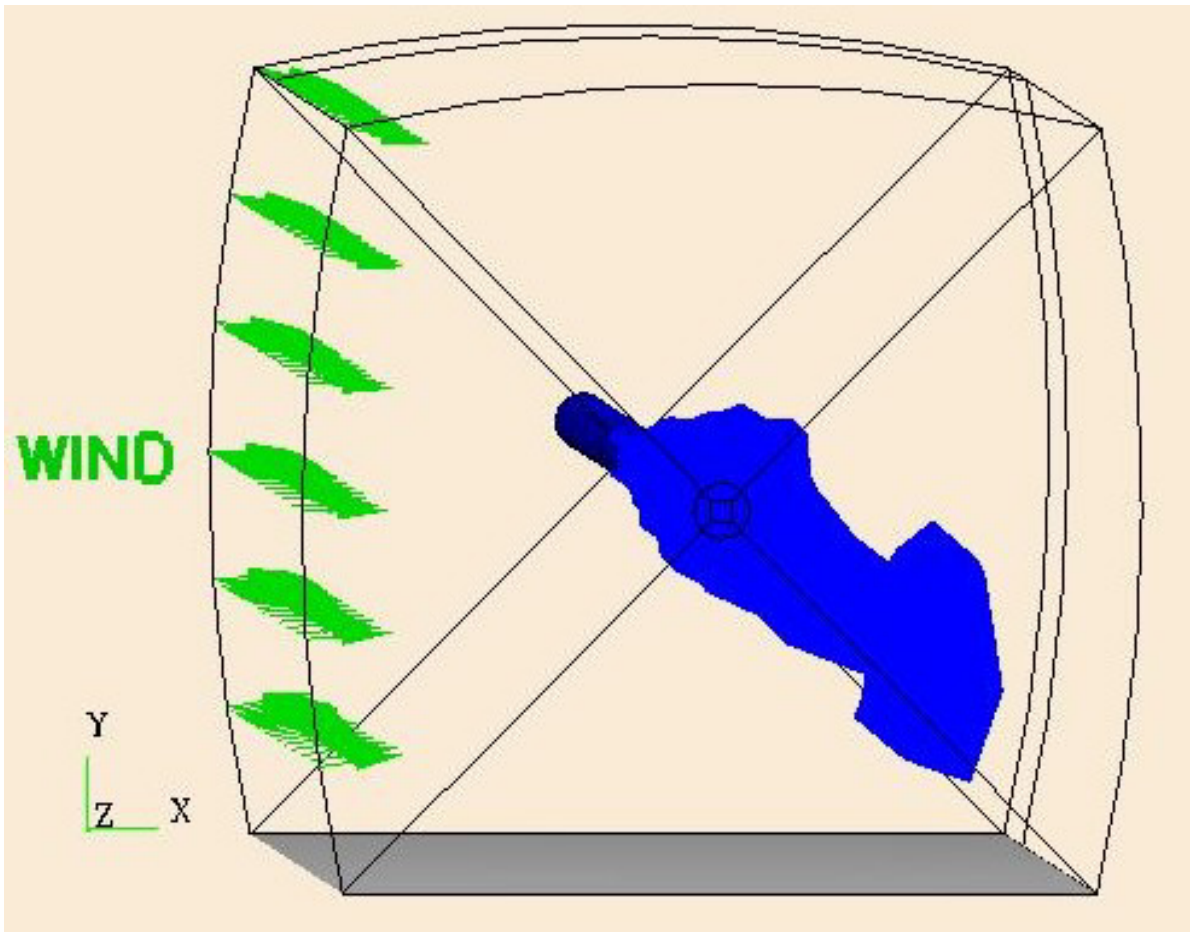

Figure 35. Angled View: Trial 4, 30 (kts).

APPENDIX F. TRIAL 5

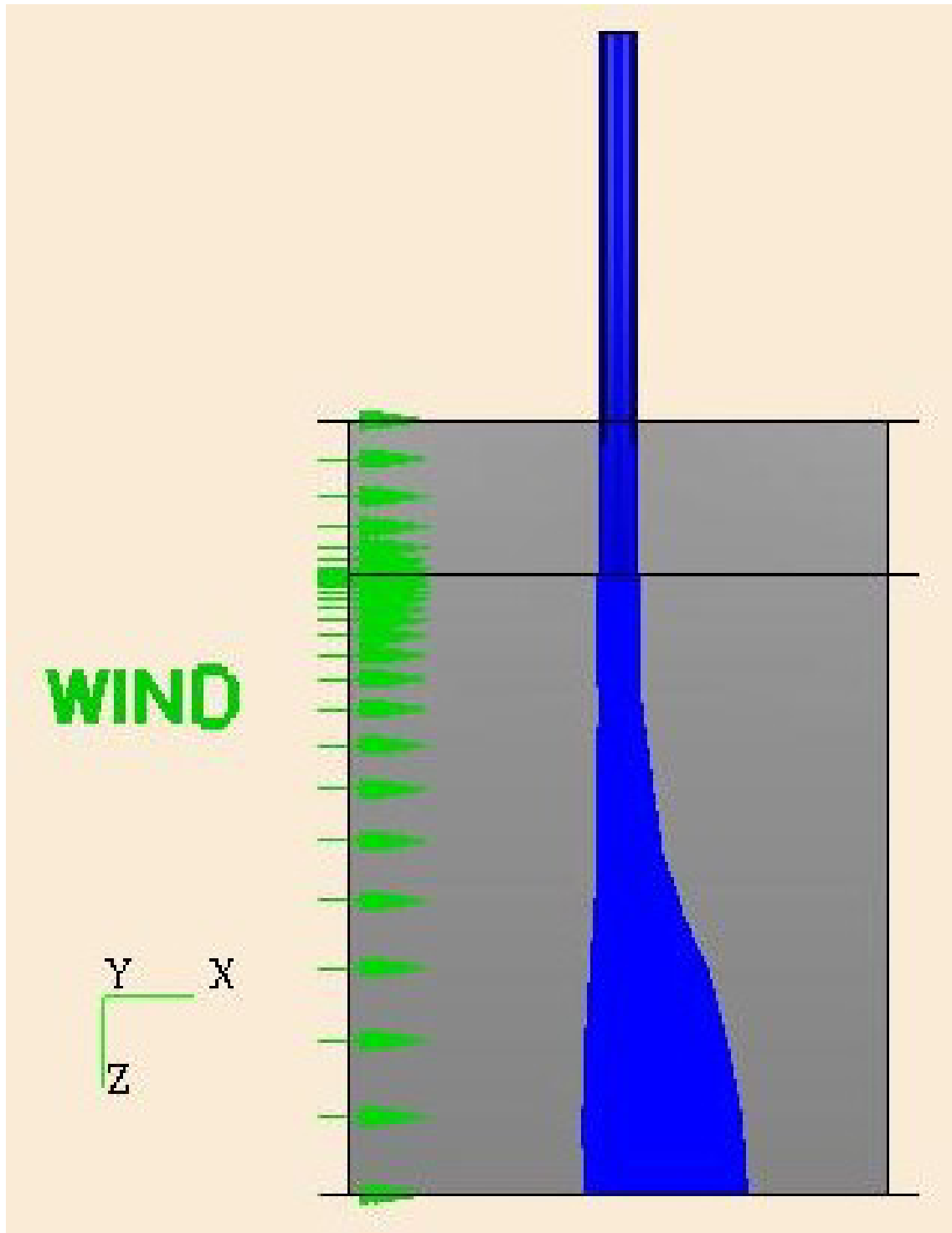

Figure 36. Plan View: Trial 5, 15 (kts).

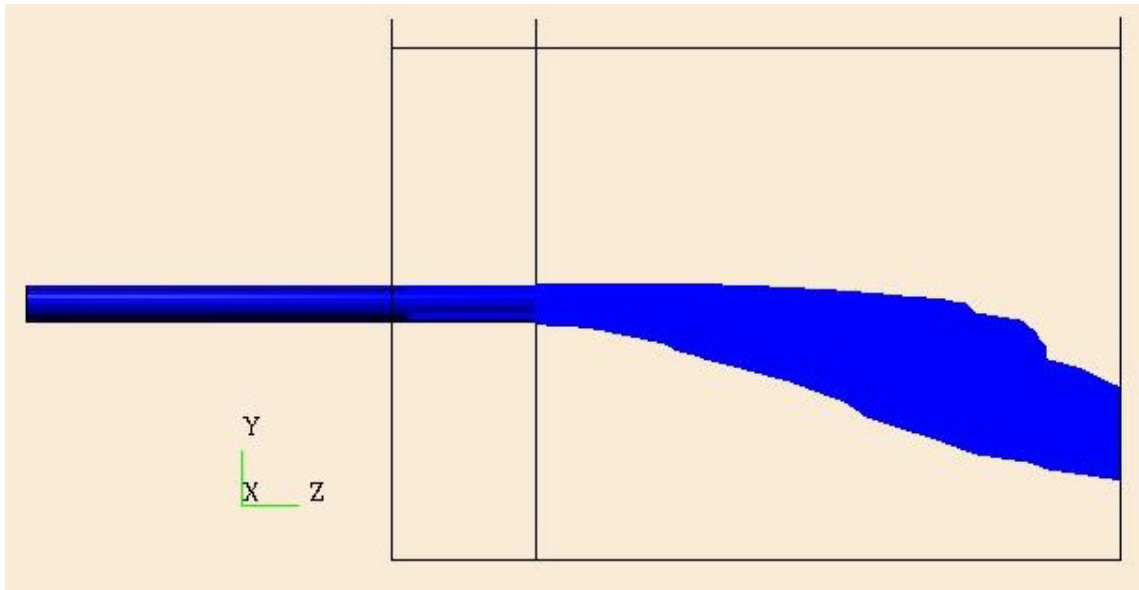

Figure 37. Side View: Trial 5, 15 (kts).

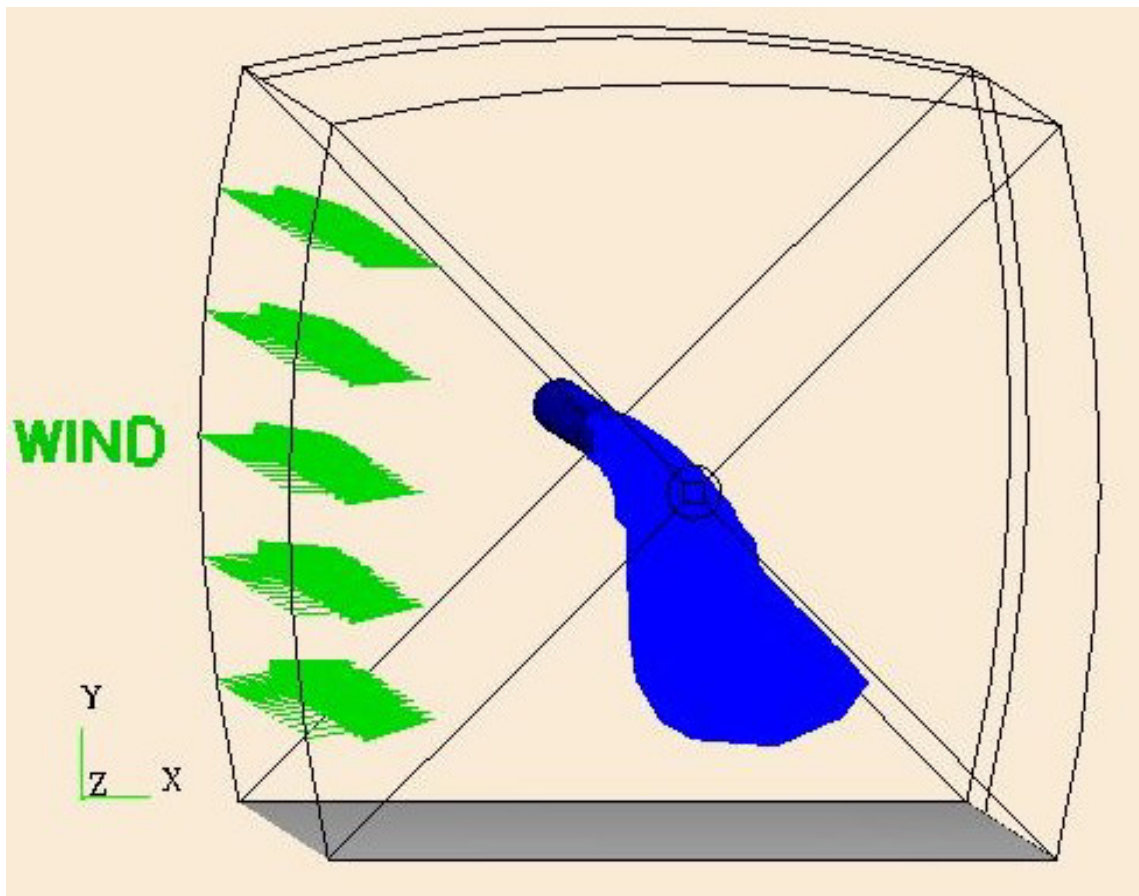

Figure 38. Angled View: Trial 5, 15 (kts).

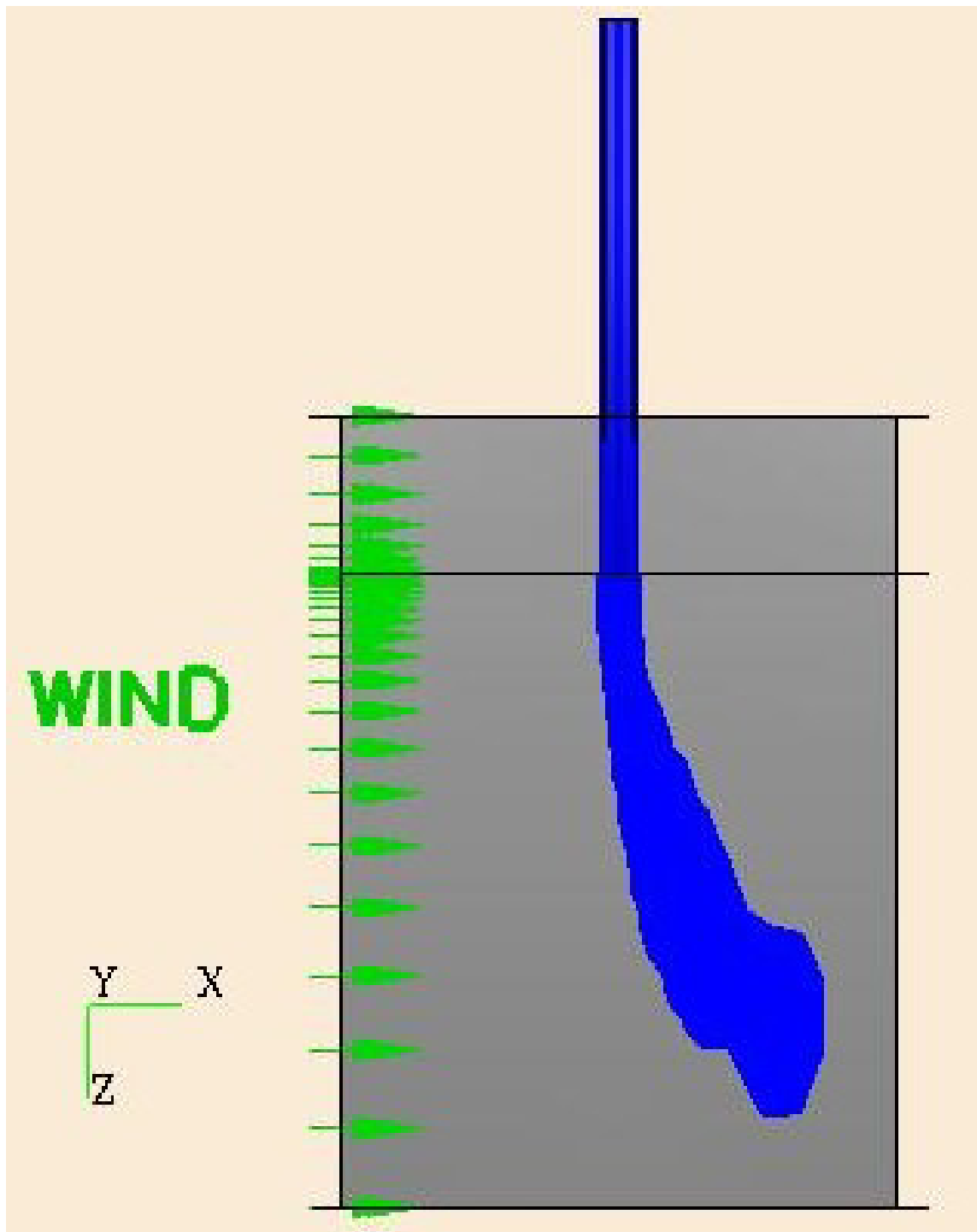

Figure 39. Plan View: Trial 5, 30 (kts).

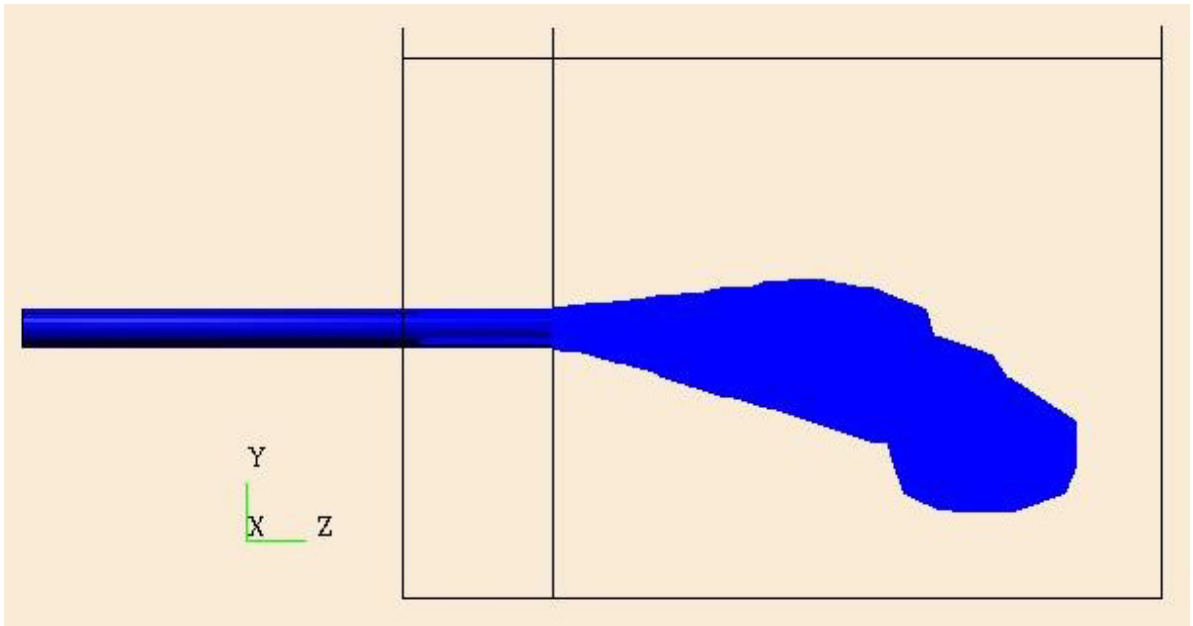

Figure 40. Side View: Trial 5, 30 (kts).

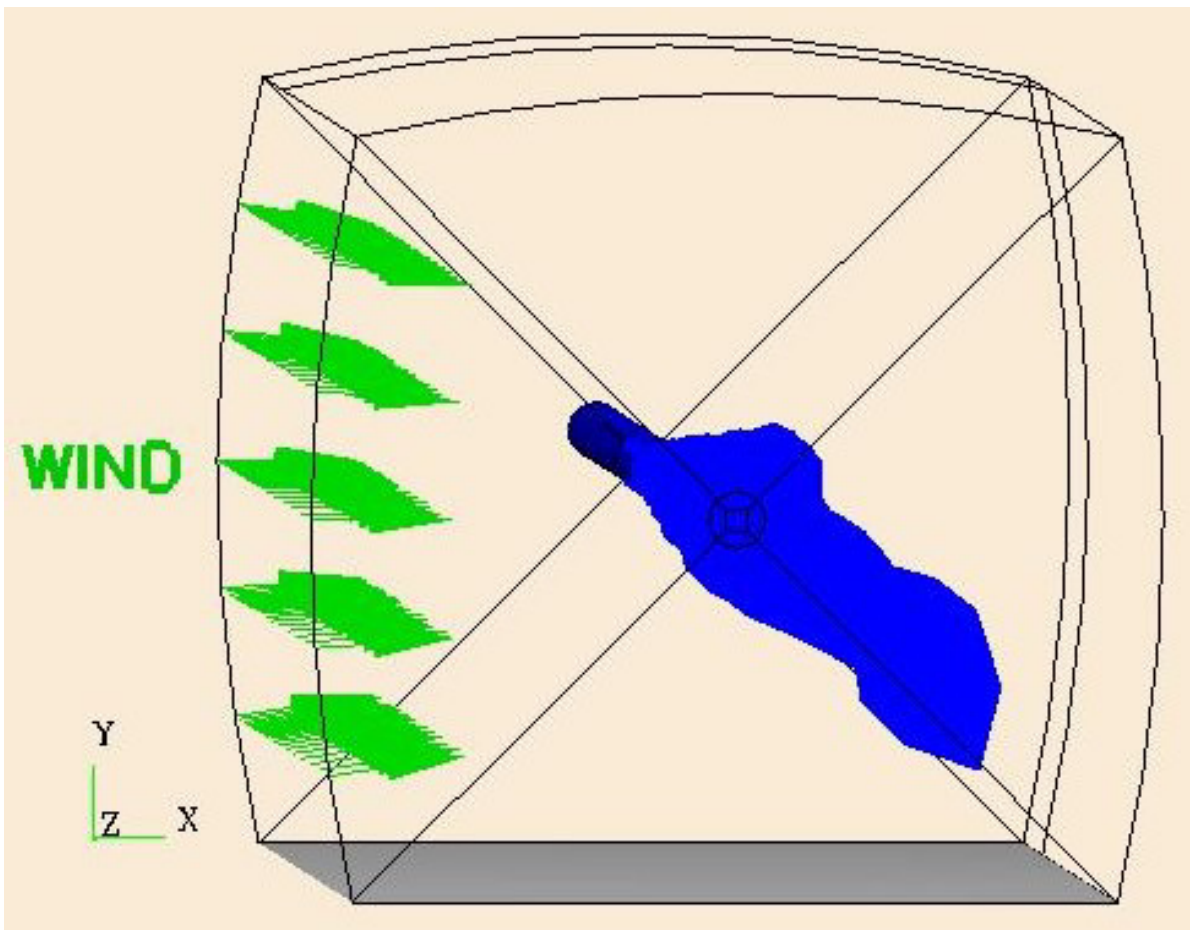

Figure 41. Angled View: Trial 5, 30 (kts).

APPENDIX G. TRIAL 6

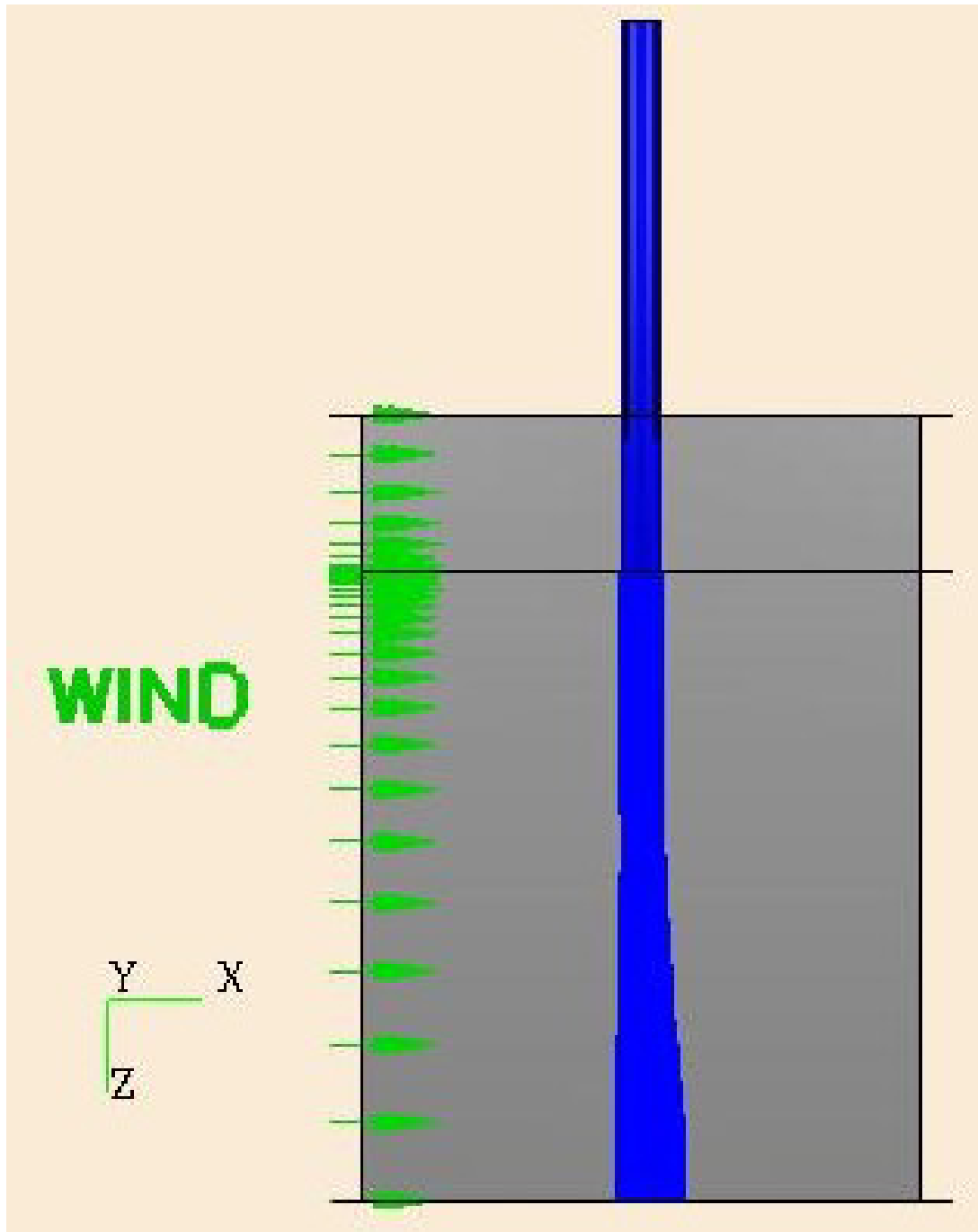

Figure 42. Plan View: Trial 6, 15 (kts).

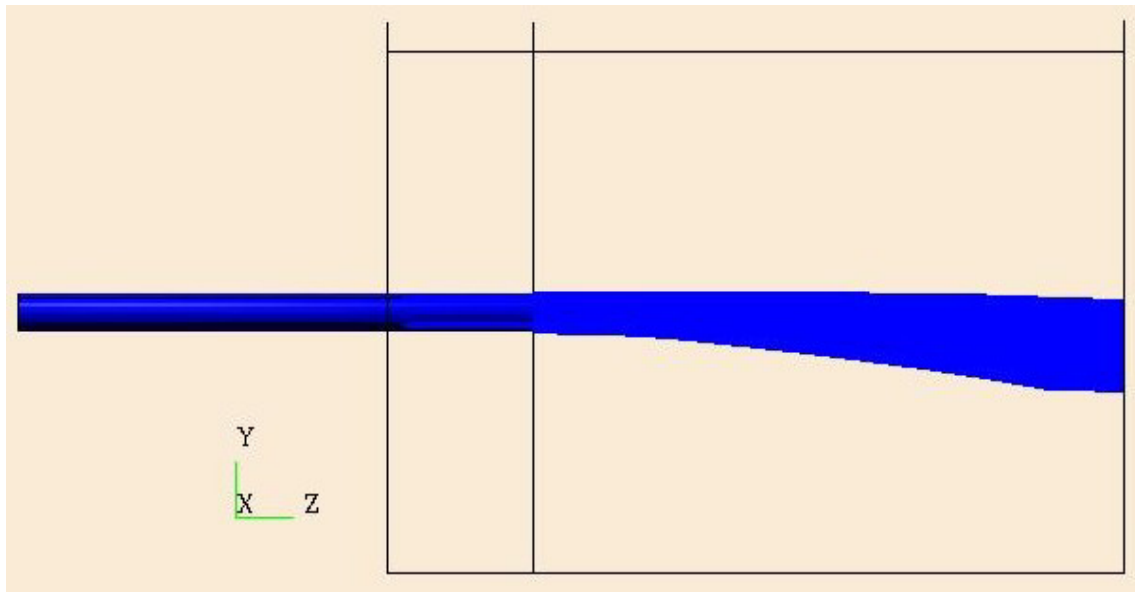

Figure 43. Side View: Trial 6, 15 (kts).

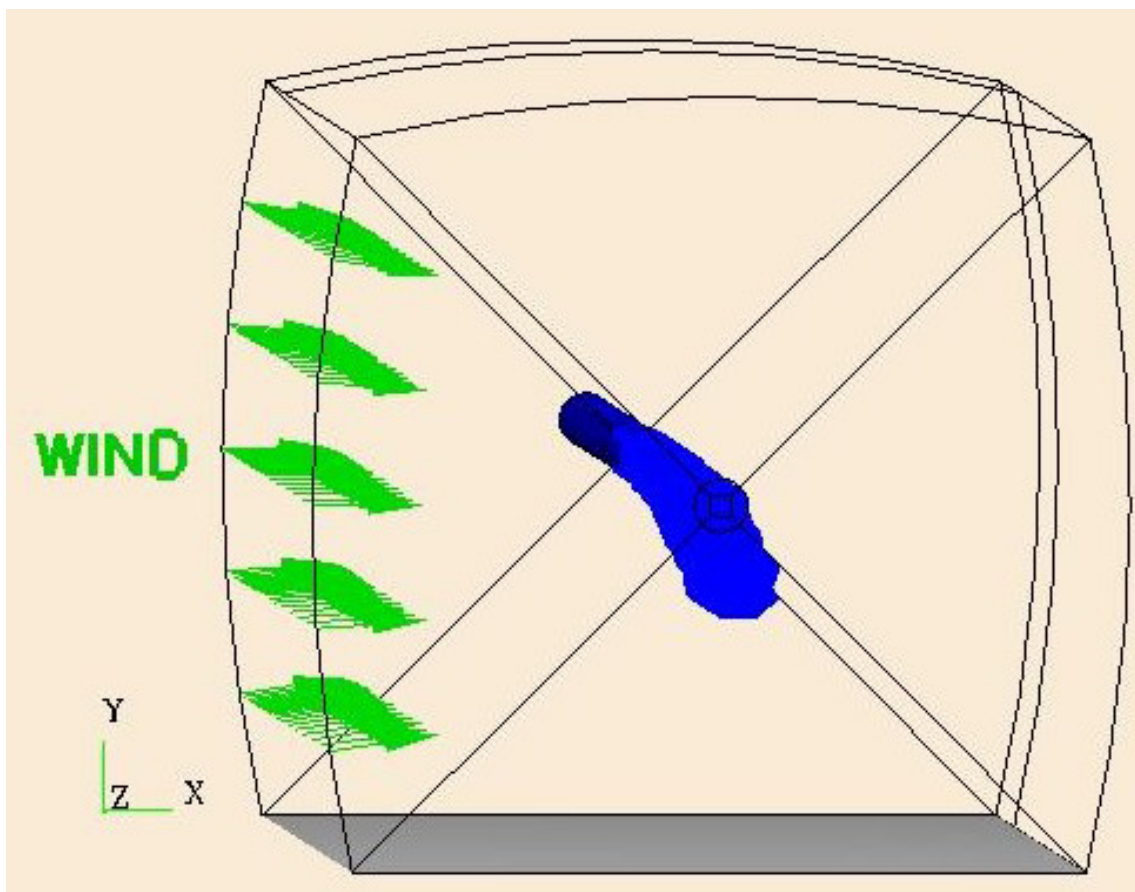

Figure 44. Angled View: Trial 6, 15 (kts).

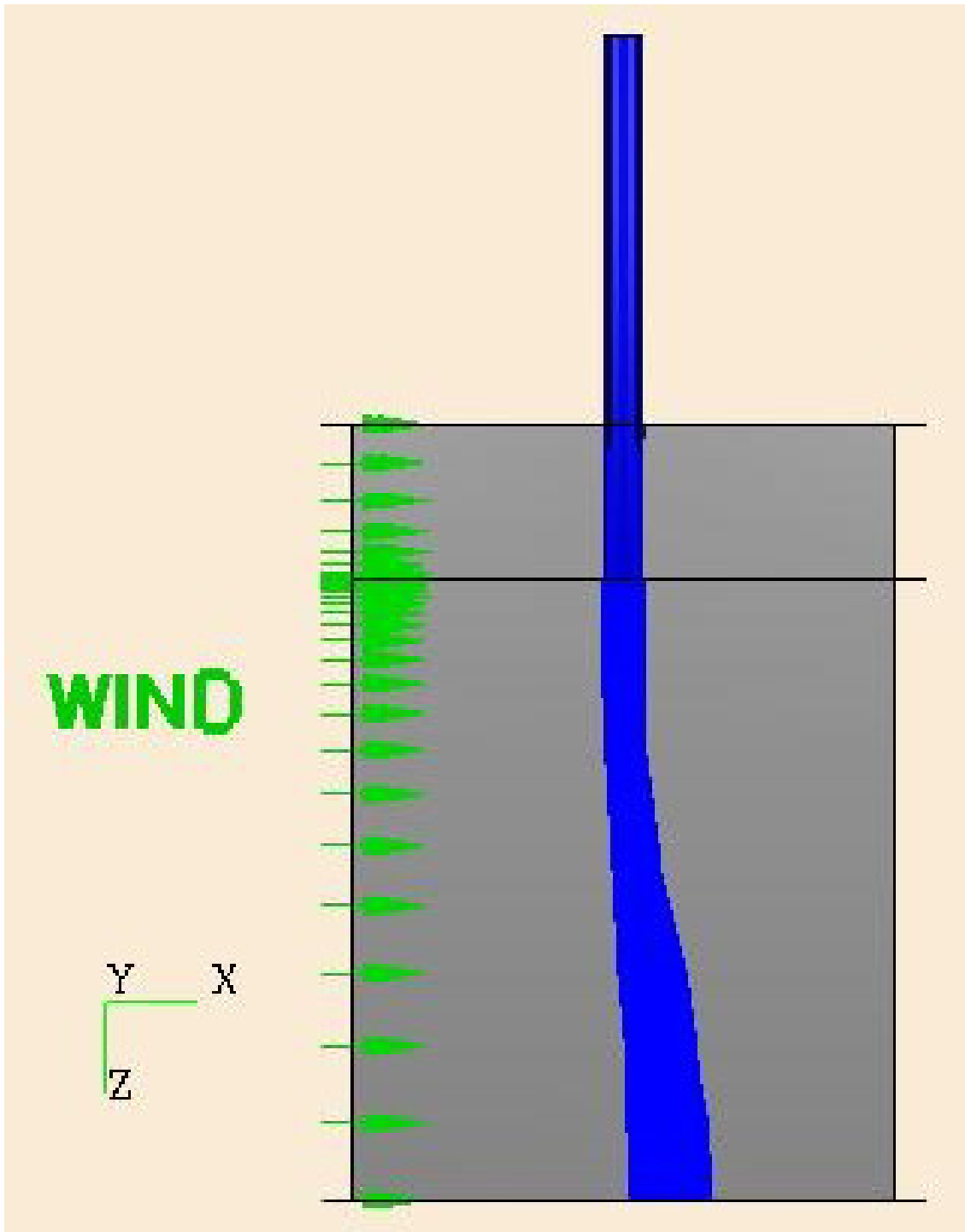

Figure 45. Plan View: Trial 6, 30 (kts).

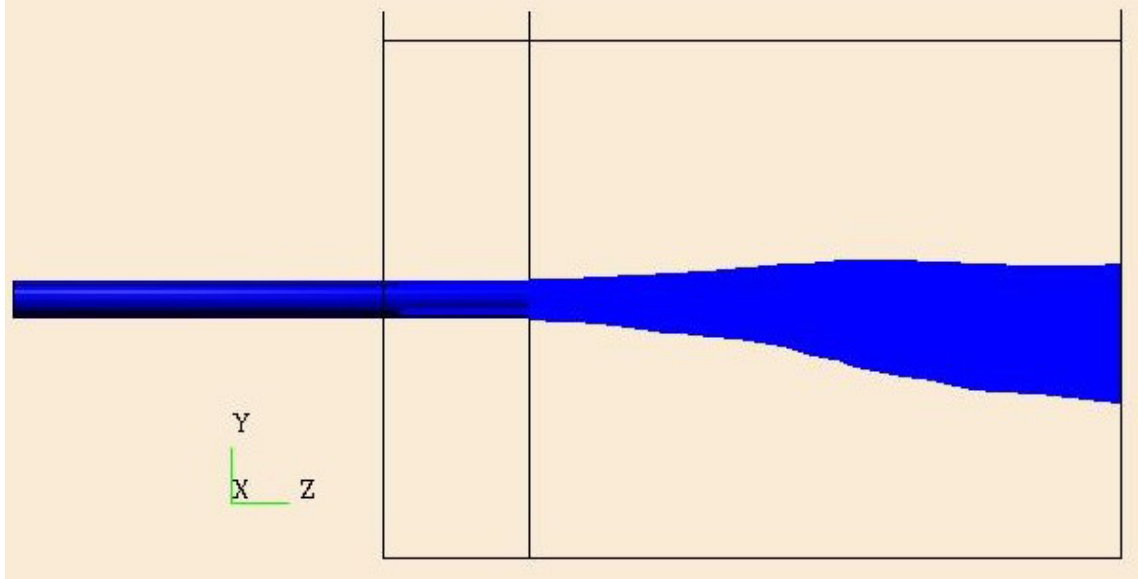

Figure 46. Side View: Trial 6, 30 (kts).

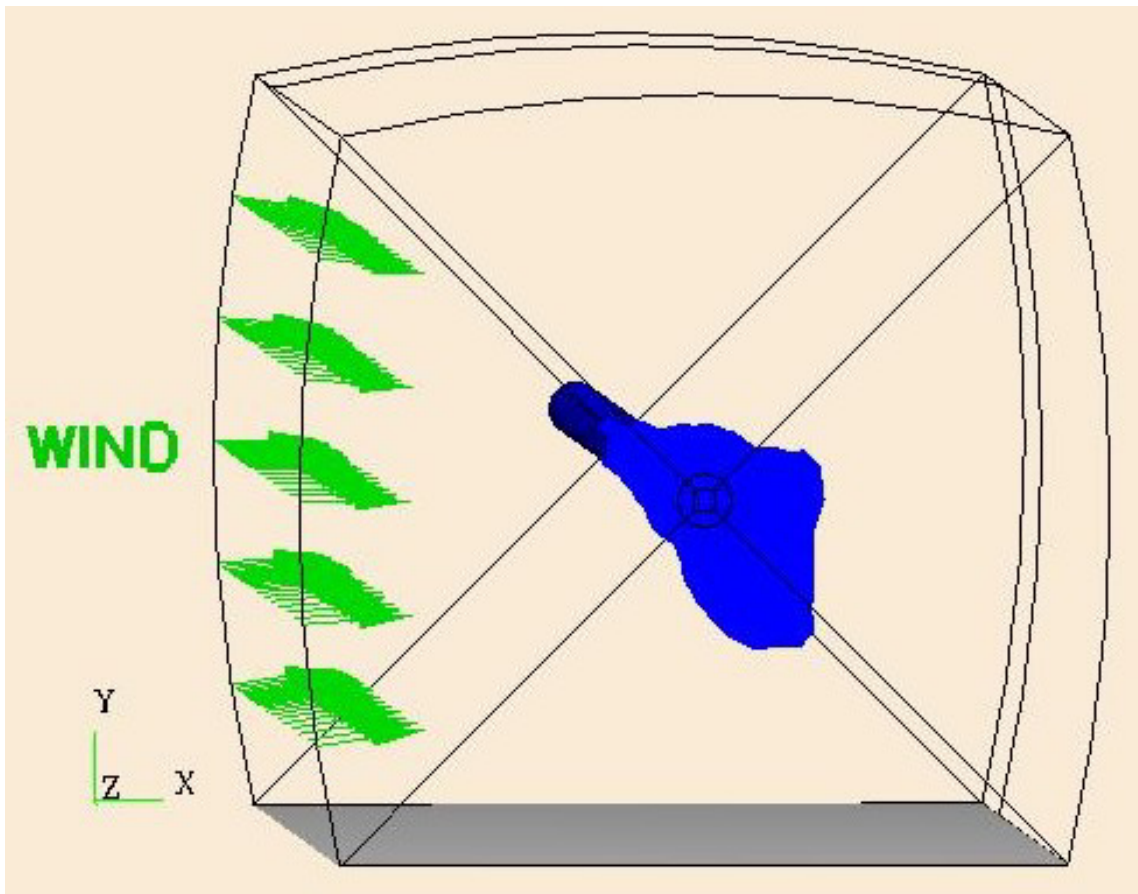

Figure 47. Angled View: Trial 6, 30 (kts).

APPENDIX H. TRIAL 7

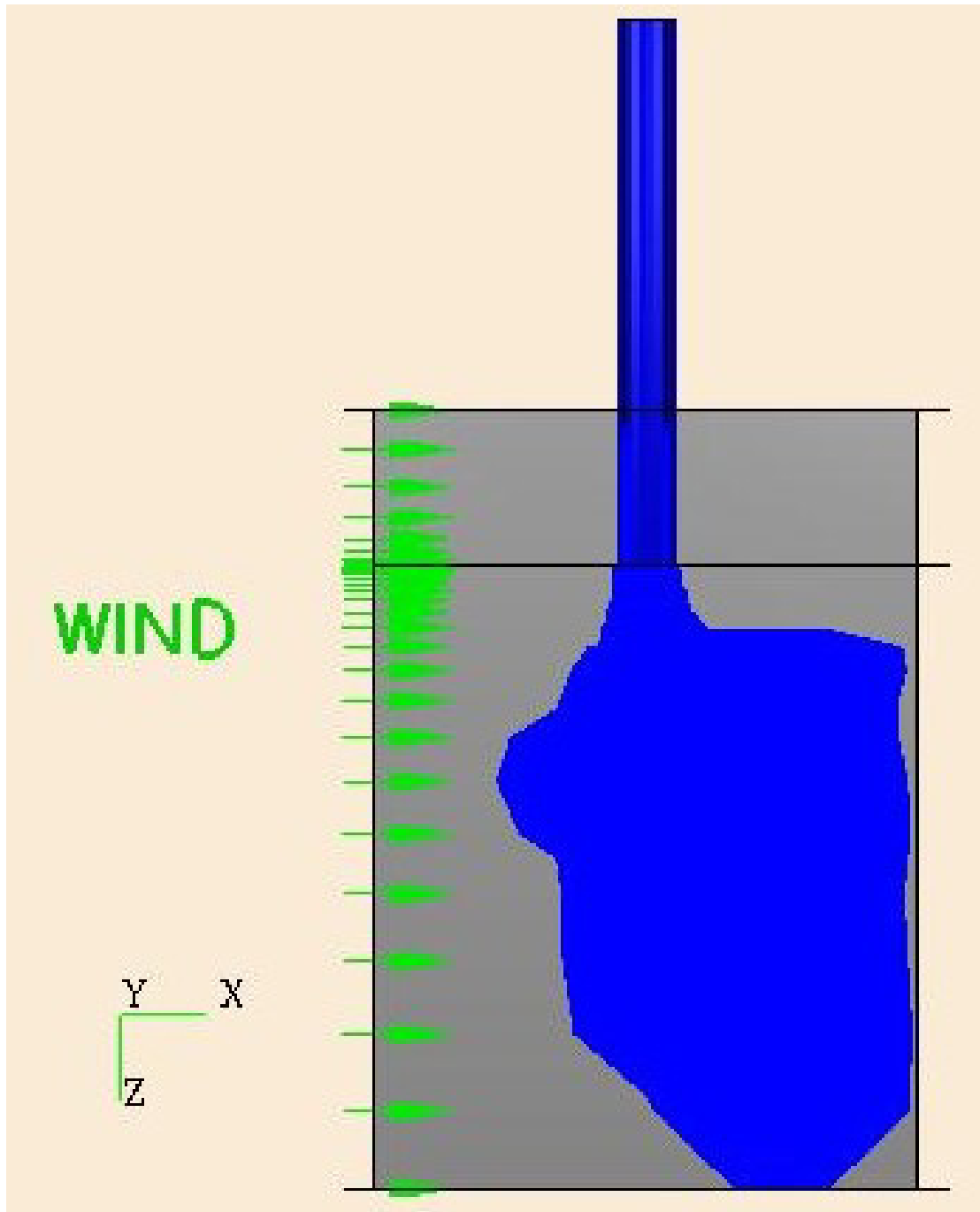

Figure 48. Plan View: Trial 7, 15 (kts).

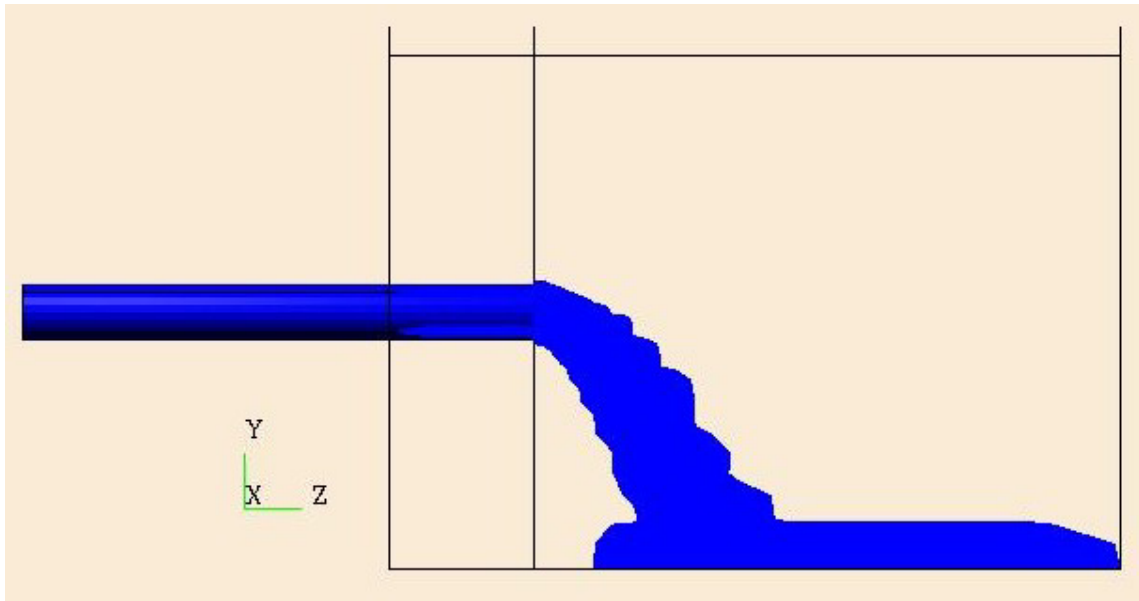

Figure 49. Side View: Trial 7, 15 (kts).

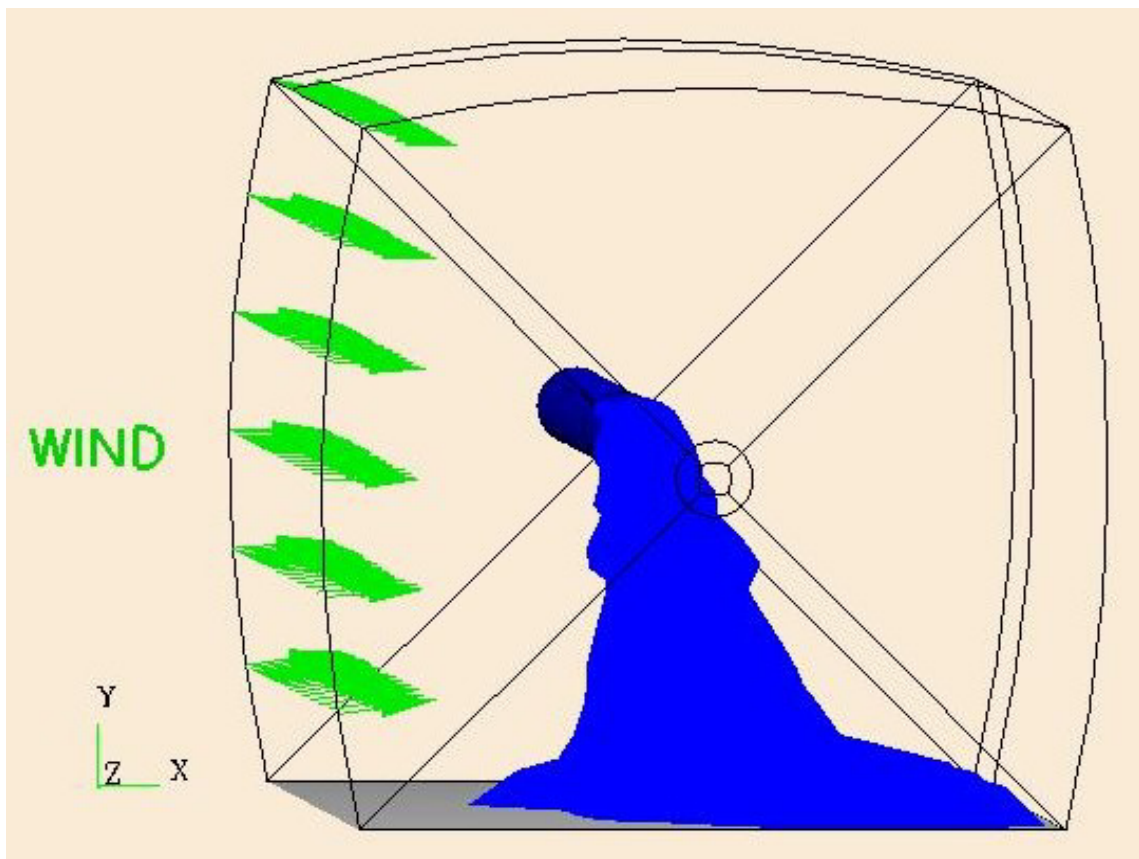

Figure 50. Angled View: Trial 7, 15 (kts).

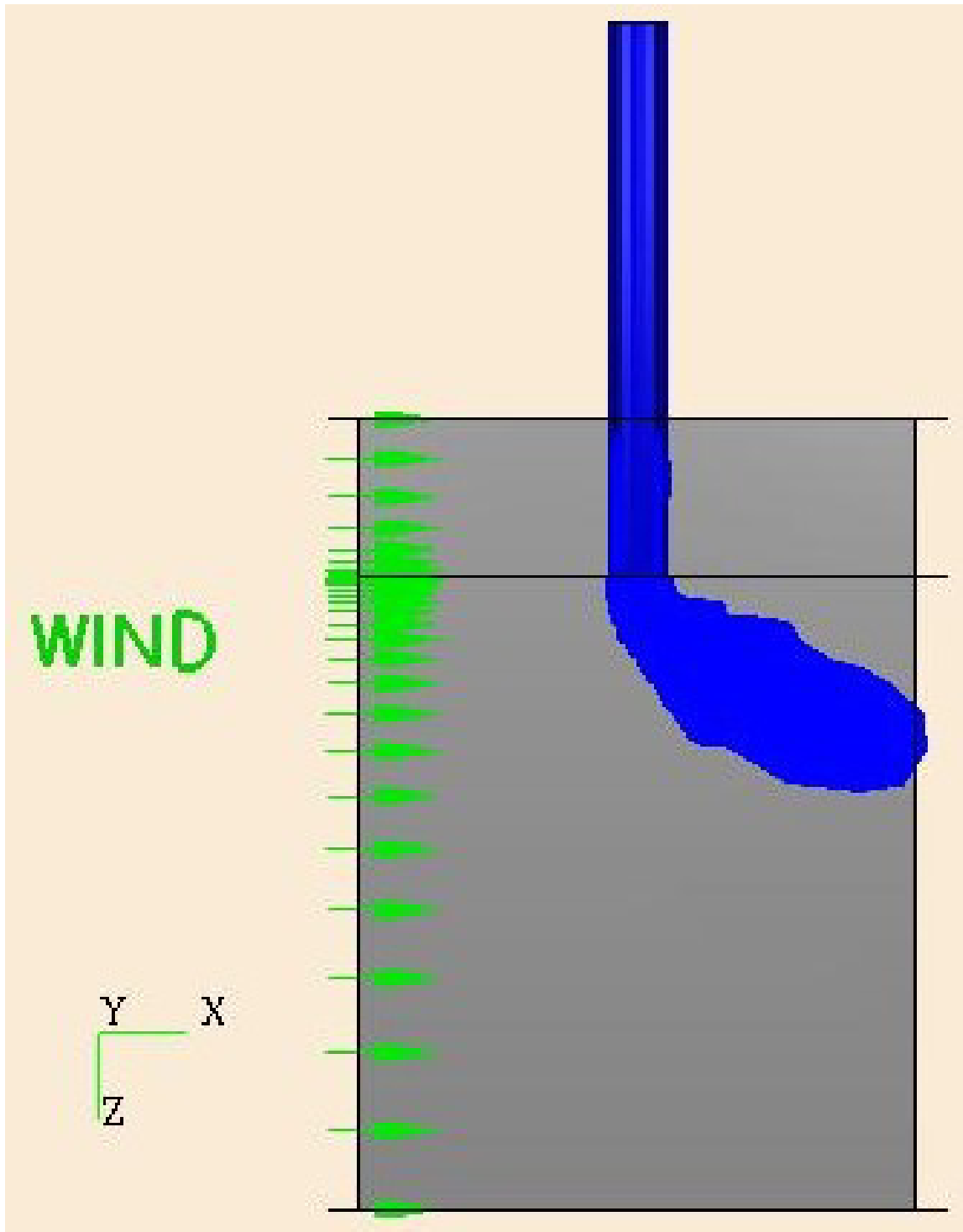

Figure 51. Plan View: Trial 7, 30 (kts).

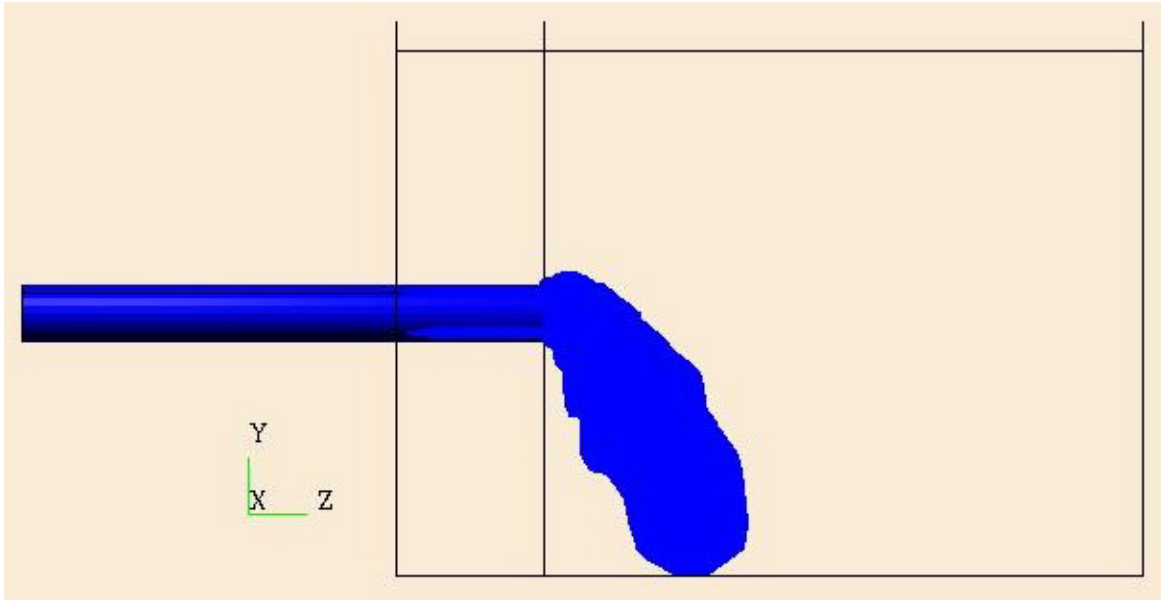

Figure 52. Side View: Trial 7, 30 (kts).

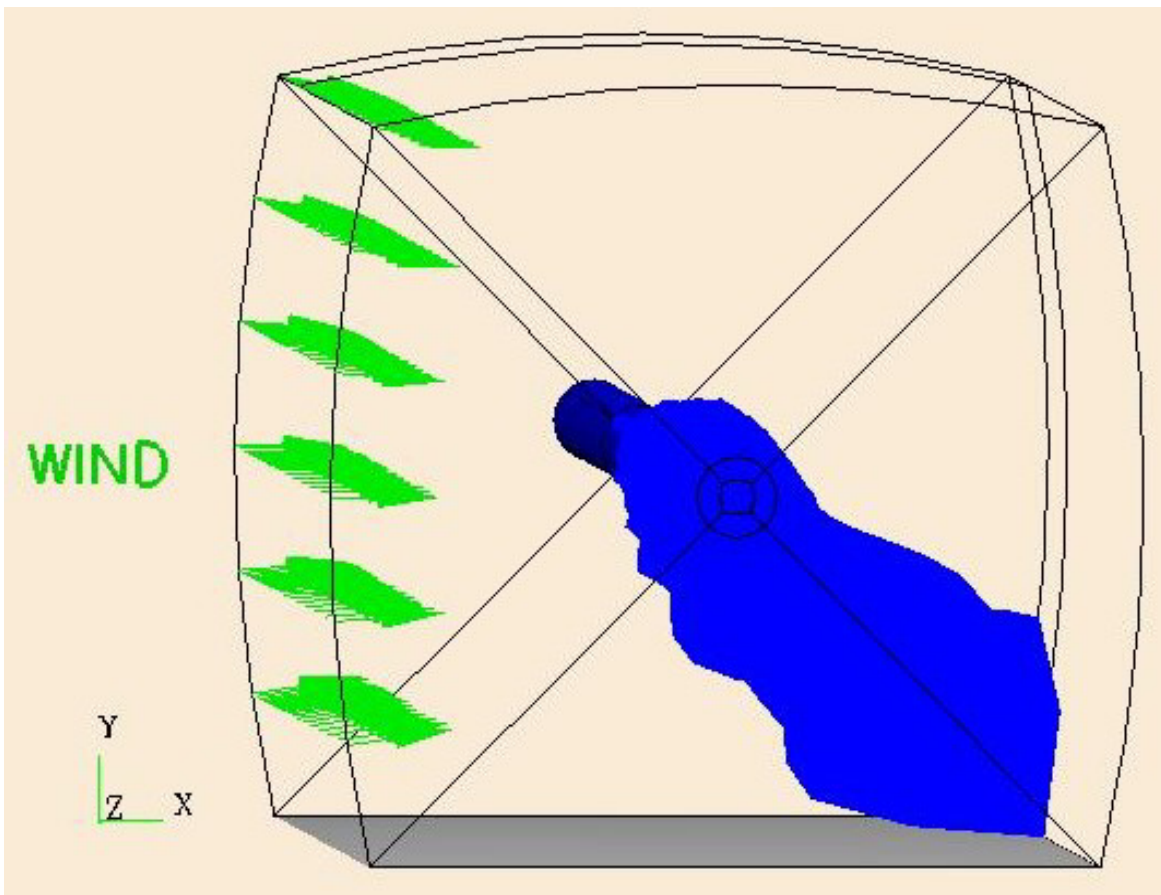

Figure 53. Angled View: Trial 7, 30 (kts).

APPENDIX I. TRIAL 8

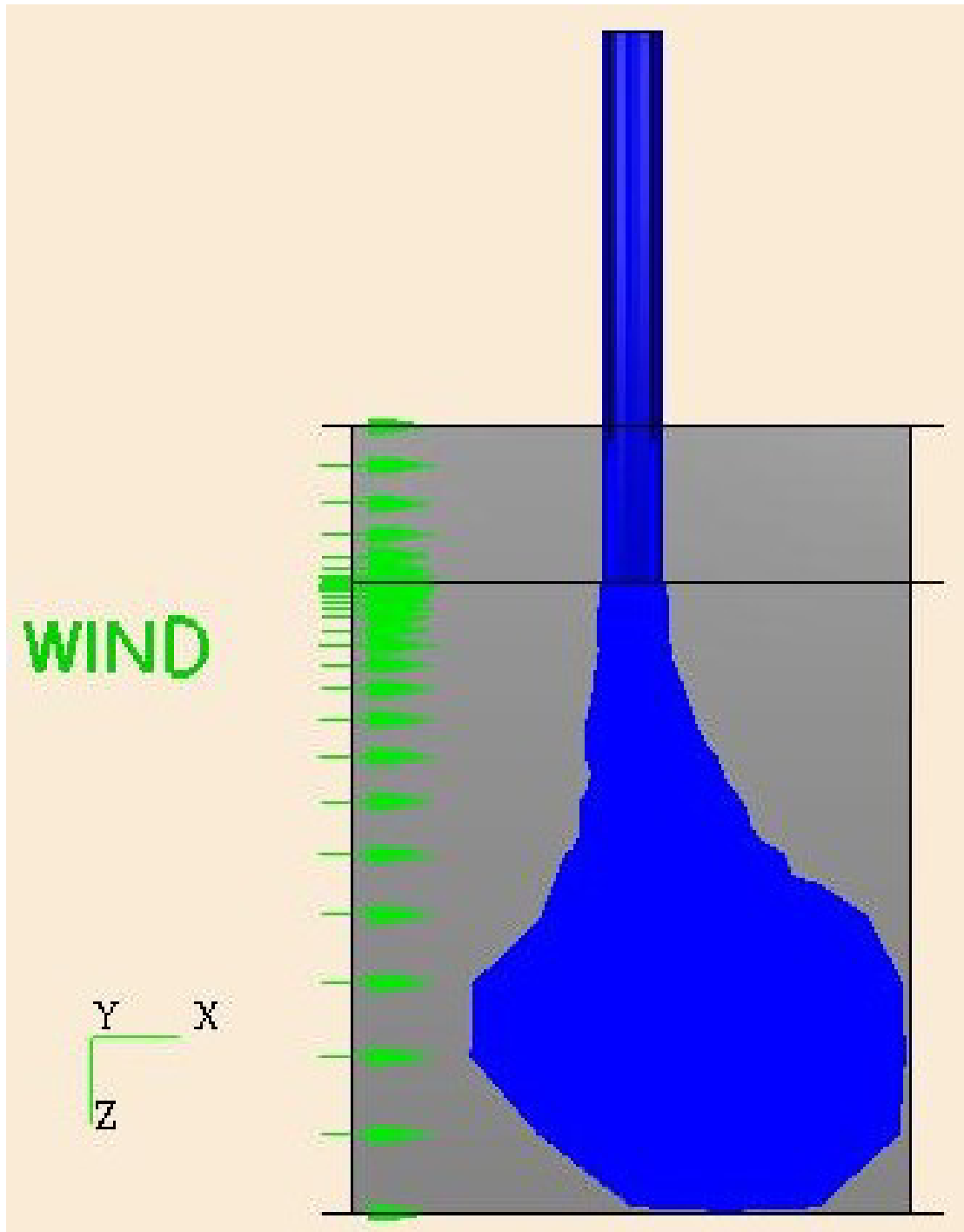

Figure 54. Plan View: Trial 8, 15 (kts).

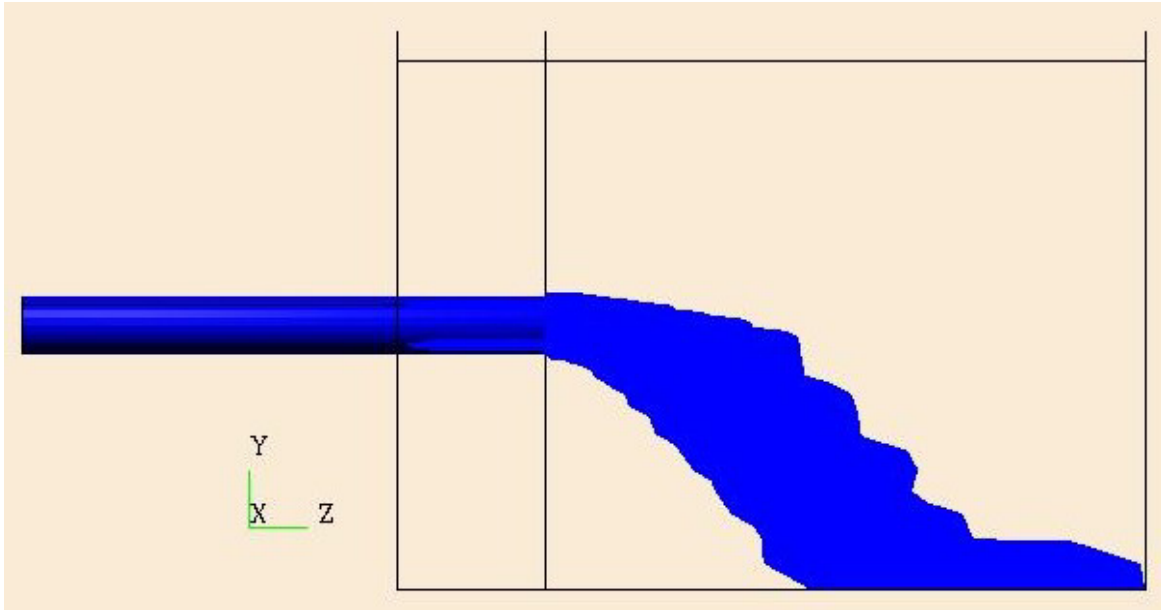

Figure 55. Side View: Trial 8, 15 (kts).

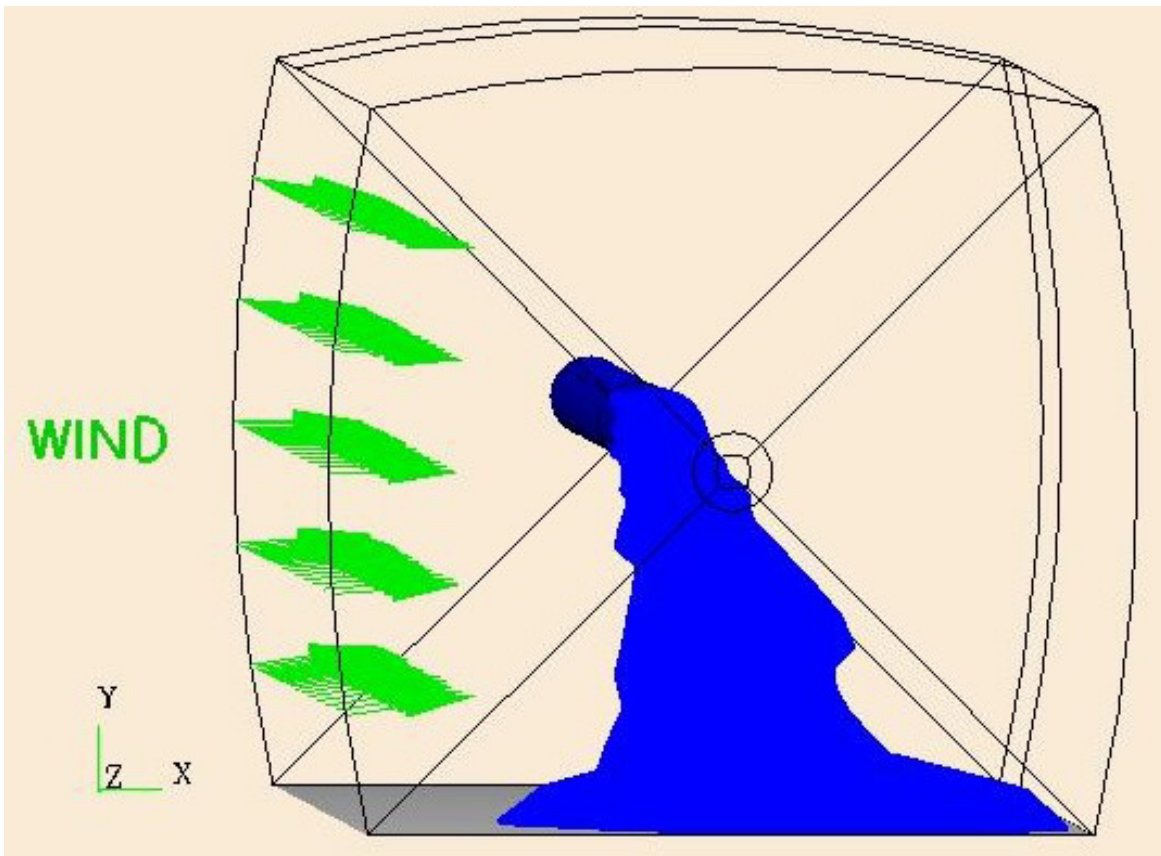

Figure 56. Angled View: Trial 8, 15 (kts).

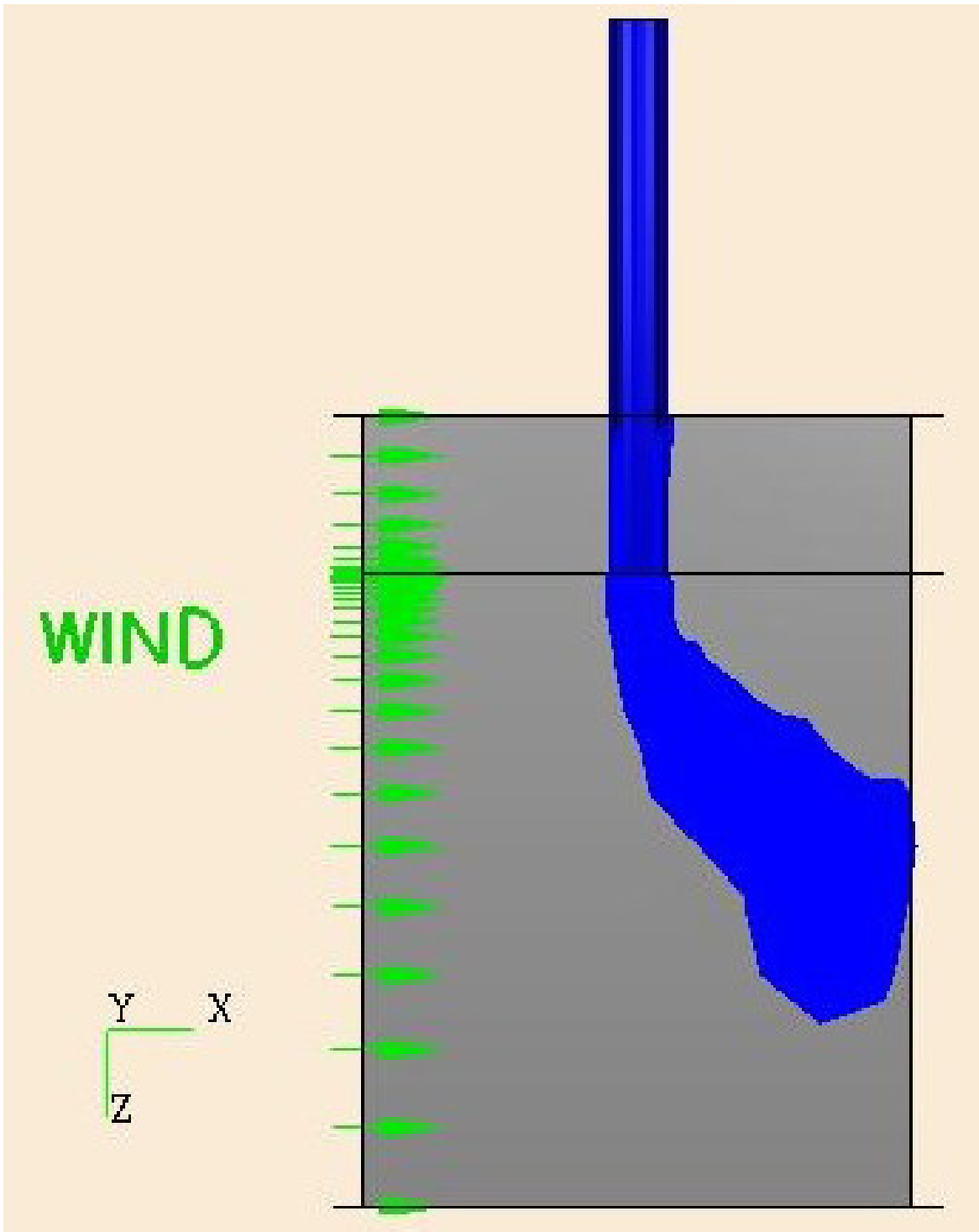

Figure 57. Plan View: Trial 8, 30 (kts).

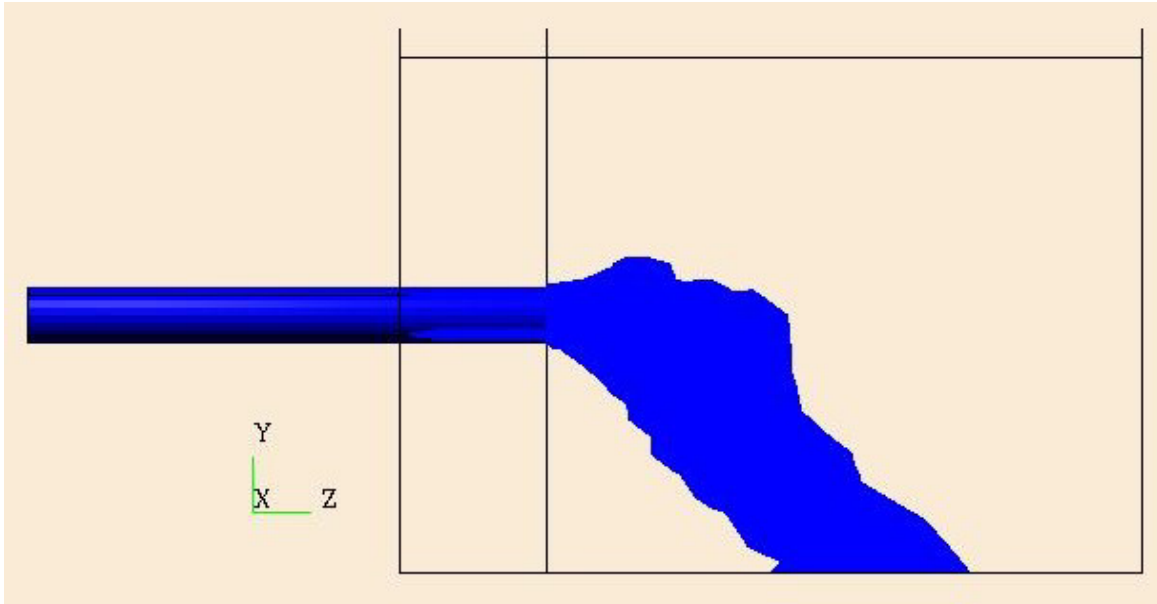

Figure 58. Side View: Trial 8, 30 (kts).

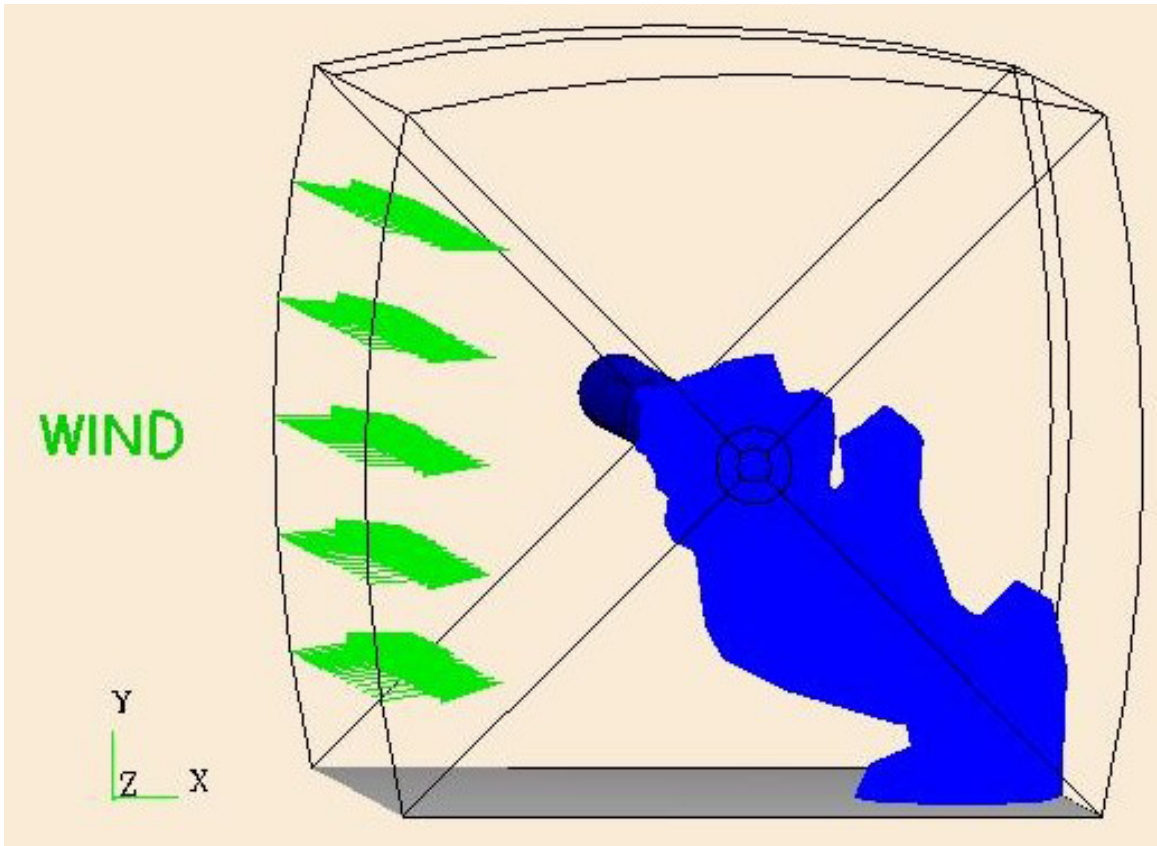

Figure 59. Angled View: Trial 8, 30 (kts).

APPENDIX J. TRIAL 9

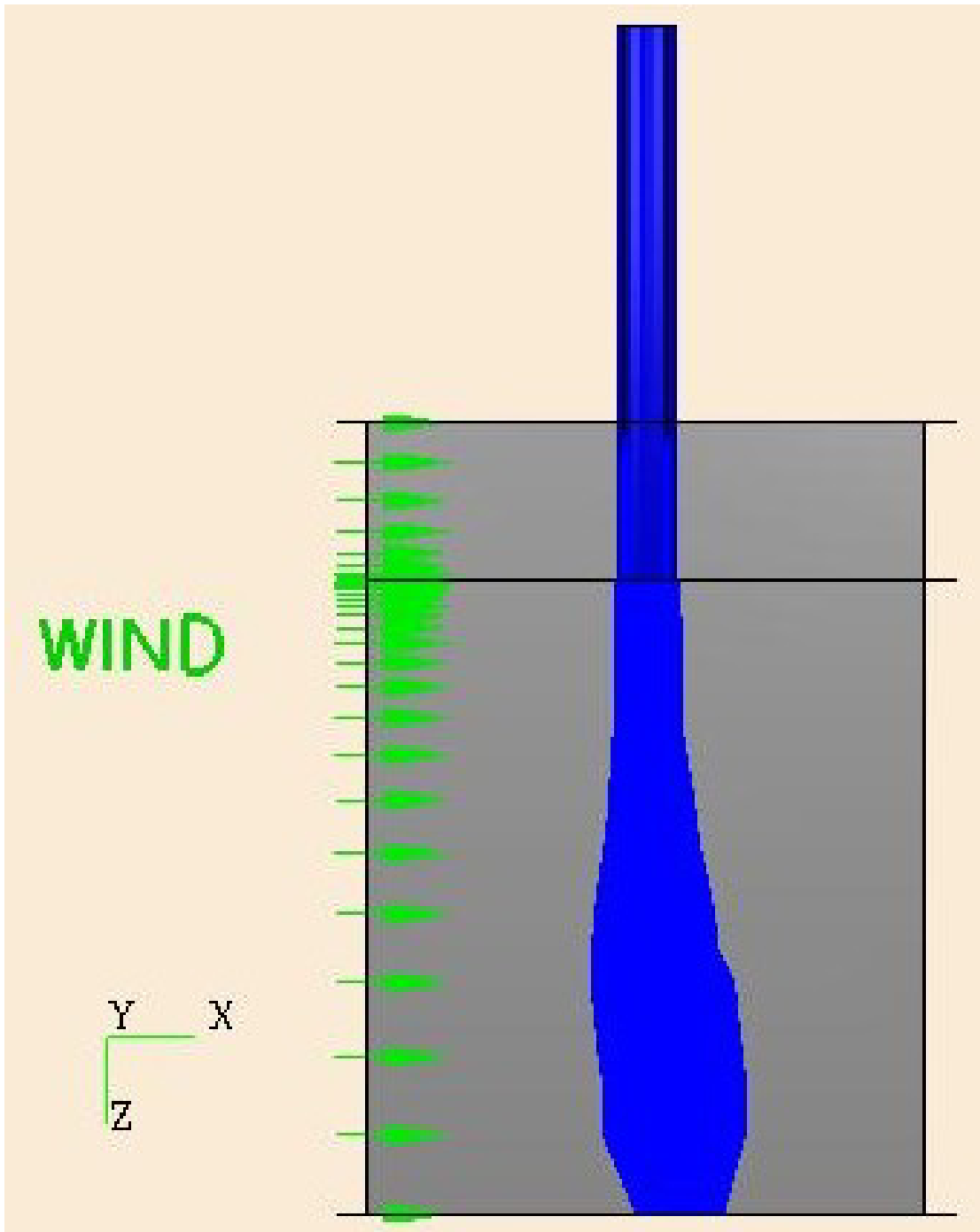

Figure 60. Plan View: Trial 9, 15 (kts).

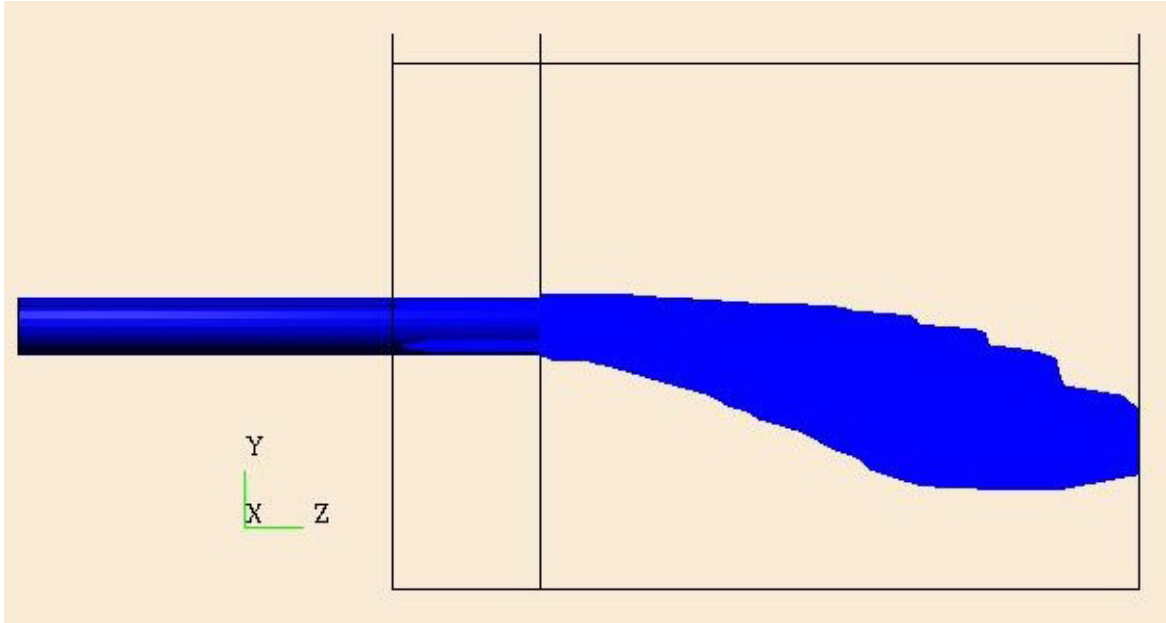

Figure 61. Side View: Trial 9, 15 (kts).

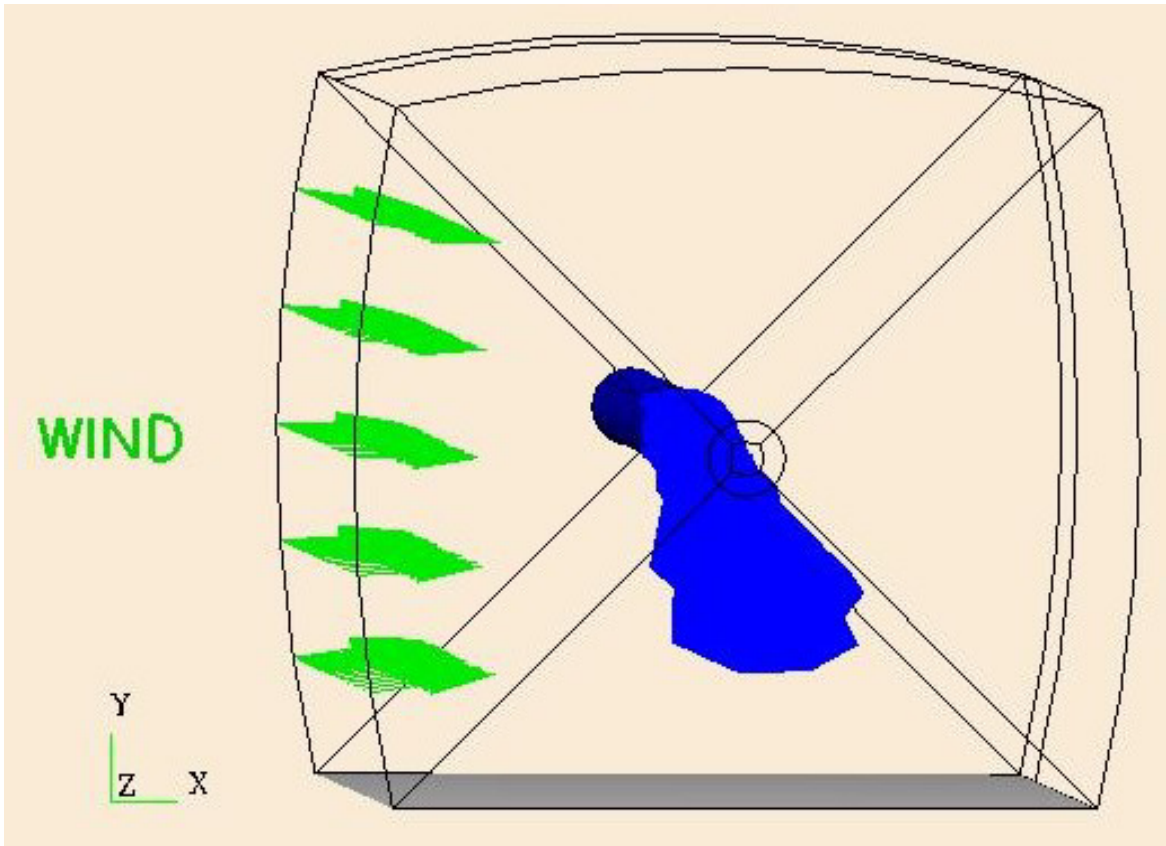

Figure 62. Angled View: Trial 9, 15 (kts).

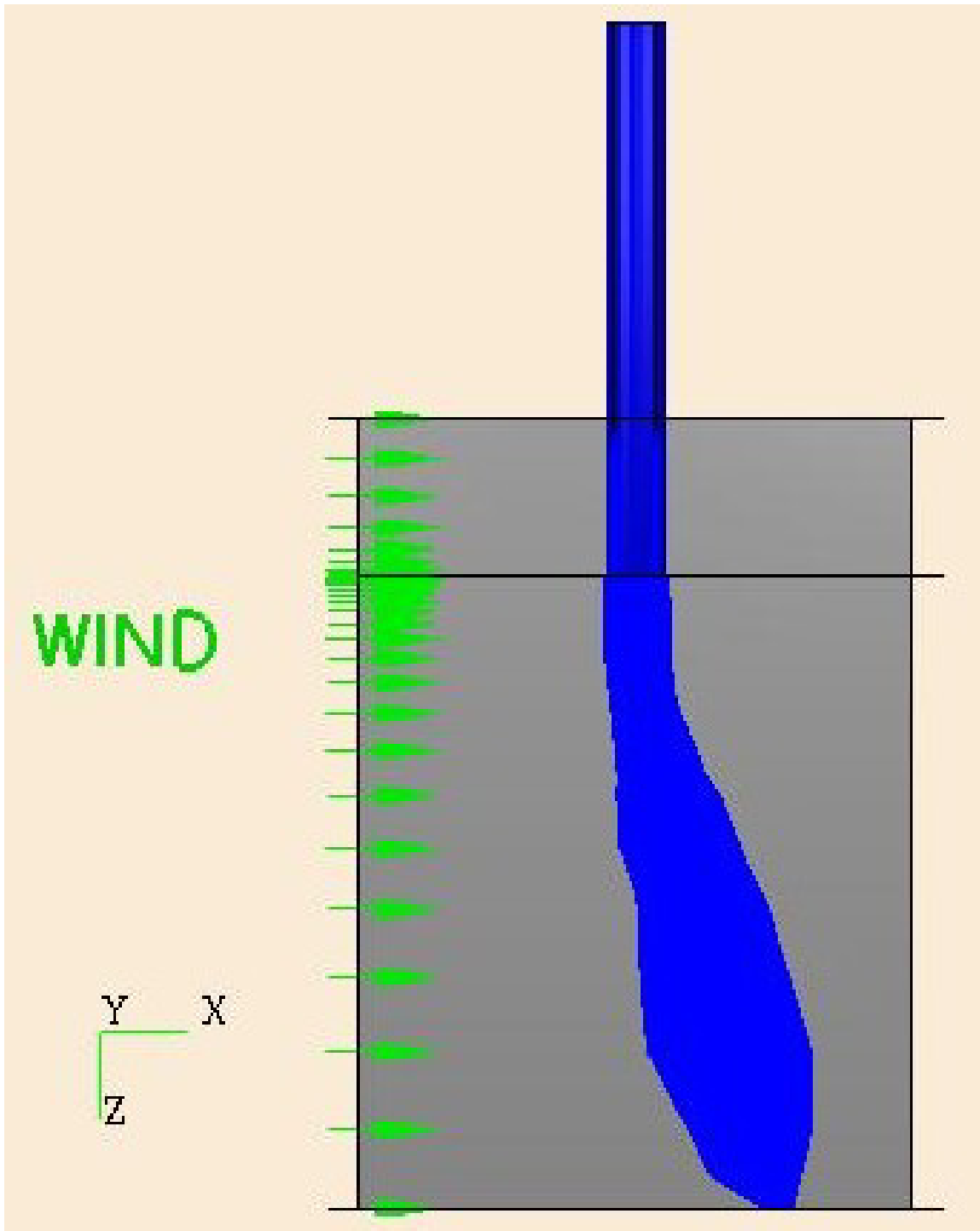

Figure 63. Plan View: Trial 9, 30 (kts).

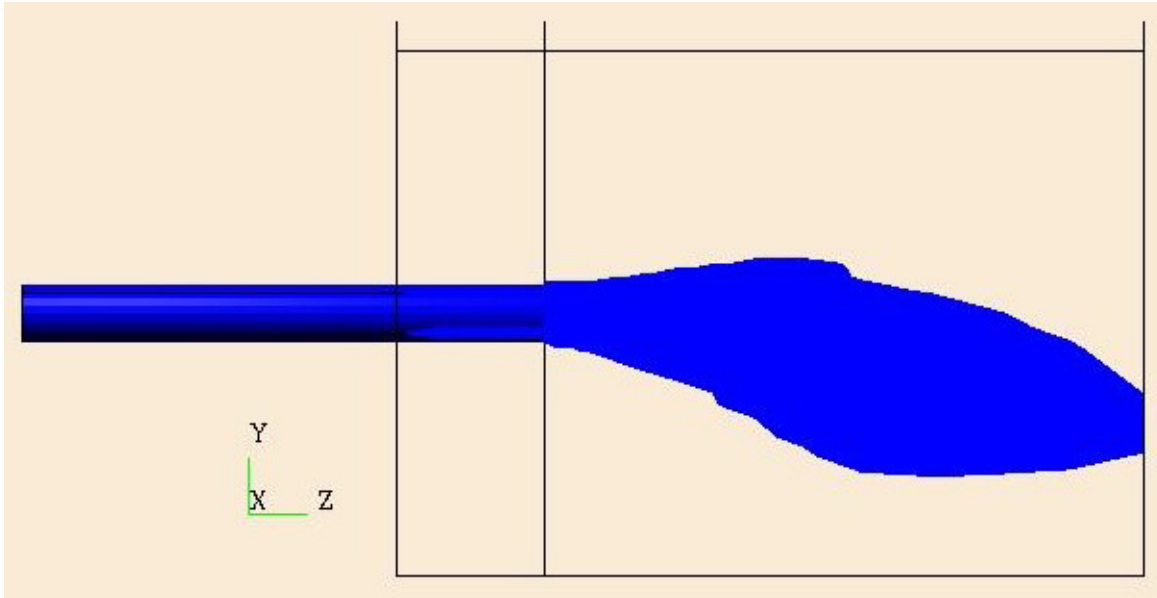

Figure 64. Side View: Trial 9, 30 (kts).

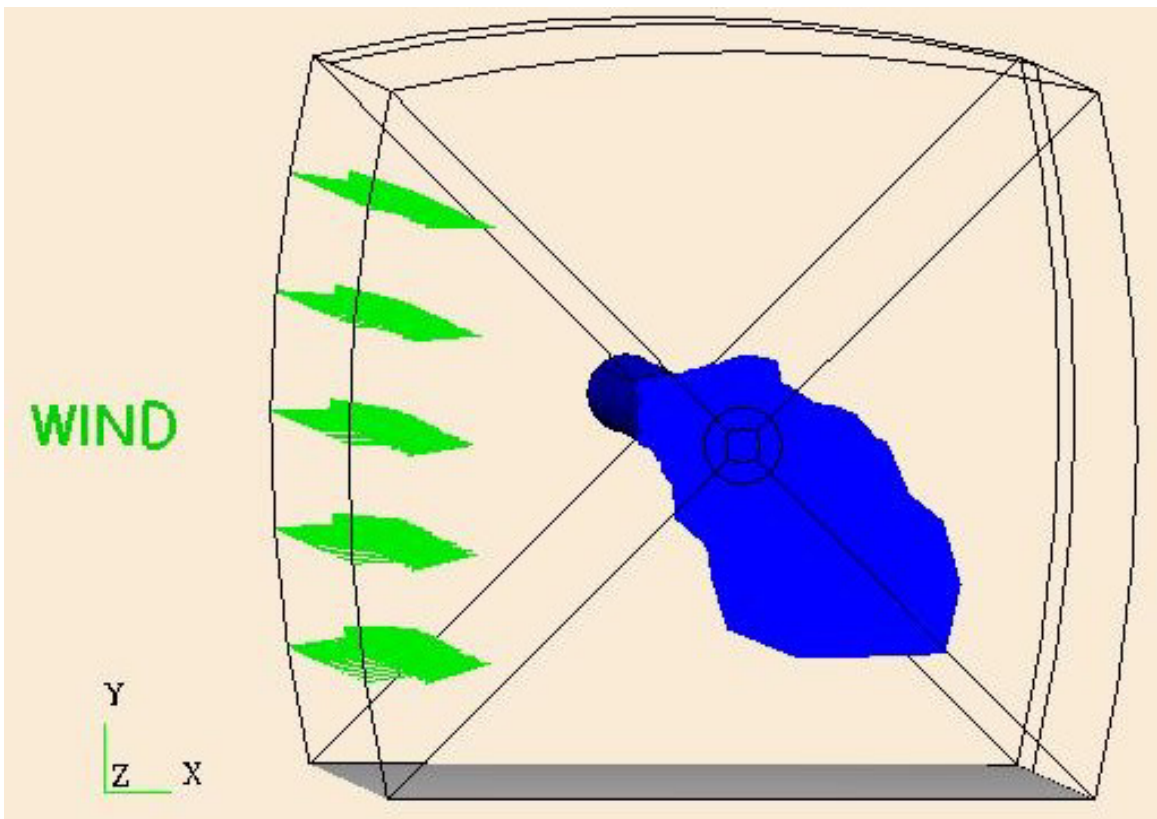

Figure 65. Angled View: Trial 9, 30 (kts).

INITIAL DISTRIBUTION LIST

1. Defense Technical Information Center
Ft. Belvoir, VA
2. Dudley Knox Library
Naval Postgraduate School
Monterey, CA
3. Matthew D. Kelleher
Professor of Mechanical Engineering
Naval Postgraduate School
Monterey, CA
4. Garth V. Hobson
Professor of Mechanical Engineering
Naval Postgraduate School
Monterey, CA
5. Alexandra Myers
New Orleans, LA
6. Travis Laker
Naval Air Warfare Center Weapons Division
China Lake, CA
7. H.L. Bowman
Naval Air Warfare Center Weapons Division
China Lake, CA