



**NAVAL
POSTGRADUATE
SCHOOL**

MONTEREY, CALIFORNIA

THESIS

**IMPROVING THE PERFORMANCE OF MINICAN
LOW NOISE HYDROPHONE**

by

Mario Magliocchetti

June 2004

Thesis Advisor:
Co-Advisor:

Thomas Hofler
Bruce Denardo

Approved for public release: distribution is unlimited

THIS PAGE INTENTIONALLY LEFT BLANK

REPORT DOCUMENTATION PAGE			Form Approved OMB No. 0704-0188	
Public reporting burden for this collection of information is estimated to average 1 hour per response, including the time for reviewing instruction, searching existing data sources, gathering and maintaining the data needed, and completing and reviewing the collection of information. Send comments regarding this burden estimate or any other aspect of this collection of information, including suggestions for reducing this burden, to Washington headquarters Services, Directorate for Information Operations and Reports, 1215 Jefferson Davis Highway, Suite 1204, Arlington, VA 22202-4302, and to the Office of Management and Budget, Paperwork Reduction Project (0704-0188) Washington DC 20503.				
1. AGENCY USE ONLY (Leave blank)	2. REPORT DATE June 2004	3. REPORT TYPE AND DATES COVERED Master's Thesis		
4. TITLE AND SUBTITLE: Improving the Performance of MiniCan Low Noise Hydrophones			5. FUNDING NUMBERS	
6. AUTHOR(S) Mario Magliocchetti				
7. PERFORMING ORGANIZATION NAME(S) AND ADDRESS(ES) Naval Postgraduate School Monterey, CA 93943-5000			8. PERFORMING ORGANIZATION REPORT NUMBER	
9. SPONSORING /MONITORING AGENCY NAME(S) AND ADDRESS(ES) N/A			10. SPONSORING/MONITORING AGENCY REPORT NUMBER	
11. SUPPLEMENTARY NOTES The views expressed in this thesis are those of the author and do not reflect the official policy or position of the Department of Defense or the U.S. Government.				
12a. DISTRIBUTION / AVAILABILITY STATEMENT Approved for public release; Distribution is unlimited			12b. DISTRIBUTION CODE A	
13. ABSTRACT (maximum 200 words) The MiniCan hydrophone is a small, easy to build, preamplified hydrophone with similar characteristics in sensitivity and self noise to larger and more expensive commercial devices. Previous work on the design showed a very promising performance, though it proved to have a flat sensitivity response of only up to 14 kHz. Unknown were also the effects that the aluminum housing parts produced on the overall response and whether the cable of the hydrophone had some influence on the sensitivity. A new design was built and tested changing the dimensions of the aluminum housing for the hydrophone, resulting in an increase in the region of flat sensitivity response up to 20 kHz and acceptable response up to 30 kHz, due to an increase of the lowest mechanical resonance of the hydrophone. A resonance testing device was built to investigate the mechanical characteristic of the components of the design, discovering that the first resonance of the aluminum base of 34.6 kHz caused the first overall resonance of the assembled device. Measurements of the influence of the cable showed an acoustic variation of about 1 dB in relative response in the range of interest, which is up to 30 kHz. The measurements proved that better performance can be achieved on the basic MiniCan design by increasing the resonant frequency of the aluminum body housing component.				
14. SUBJECT TERMS Hydrophone, Sound Receiver, Transducer			15. NUMBER OF PAGES 55	
			16. PRICE CODE	
17. SECURITY CLASSIFICATION OF REPORT Unclassified	18. SECURITY CLASSIFICATION OF THIS PAGE Unclassified	19. SECURITY CLASSIFICATION OF ABSTRACT Unclassified	20. LIMITATION OF ABSTRACT UL	

THIS PAGE INTENTIONALLY LEFT BLANK

Approved for public release; Distribution is unlimited

**IMPROVING THE PERFORMANCE OF MINICAN LOW NOISE
HYDROPHONES**

Mario Magliocchetti
Lieutenant, Chilean Navy
B.S., Chilean Naval Polytechnic Academy, 1996

Submitted in partial fulfillment of the
requirements for the degree of

MASTER OF SCIENCE IN ENGINEERING ACOUSTICS

from the

**NAVAL POSTGRADUATE SCHOOL
June 2004**

Author: Mario Magliocchetti

Approved by: Thomas Hofler
Thesis Advisor

Bruce Denardo
Co-Advisor

Kevin B. Smith
Chairman, Engineering Acoustics Academic Committee

THIS PAGE INTENTIONALLY LEFT BLANK

ABSTRACT

The MiniCan hydrophone is a small, easy to build, preamplified hydrophone with similar characteristics in sensitivity and self noise to larger and more expensive commercial devices. Previous work on the design showed a very promising performance, though it proved to have a flat sensitivity response of only up to 14 kHz. Unknown were also the effects that the aluminum housing parts produced on the overall response and whether the cable of the hydrophone had some influence on the sensitivity. A new design was built and tested changing the dimensions of the aluminum housing for the hydrophone, resulting in an increase in the region of flat sensitivity response up to 20 kHz and acceptable response up to 30 kHz, due to an increase of the lowest mechanical resonance of the hydrophone. A resonance testing device was built to investigate the mechanical characteristic of the components of the design, discovering that the first resonance of the aluminum base of 34.6 kHz caused the first overall resonance of the assembled device. Measurements of the influence of the cable showed an acoustic variation of about 1 dB in relative response in the range of interest, which is up to 30 kHz. The measurements proved that better performance can be achieved on the basic MiniCan design by increasing the resonant frequency of the aluminum body housing component.

THIS PAGE INTENTIONALLY LEFT BLANK

TABLE OF CONTENTS

I.	INTRODUCTION.....	1
A.	BACKGROUND	1
B.	PREVIOUS WORK ON THE MINICAN DESIGN.....	2
1.	Work Done by Lt. Stavros Polydorou.....	3
2.	Work Done by Lt. Miguel Alvarado J.	6
C.	MINICAN 6.....	8
II.	SCOPE AND MOTIVATION	11
A.	THEORY BEHIND THE MINICAN DESIGN	11
B.	UNDERSTANDING THE COMPONENT’S RESONANCES	12
C.	MOTIVATION FOR A NEW DESIGN	15
D.	AN UNANSWERED QUESTION.....	15
III.	CONSTRUCTION.....	17
A.	CABLE PREPARATION	17
B.	CONSTRUCTION OF THE HYDROPHONE.....	18
C.	CONSTRUCTION OF THE RESONANCE TESTING DEVICE	21
IV.	MEASUREMENTS AND DISCUSSION	23
A.	ACOUSTIC EFFECT OF CABLES	23
B.	RESONANCE TESTS RESULTS.....	25
C.	FREQUENCY RESPONSE OF SENSITIVITY	28
D.	NOISE PERFORMANCE.....	30
E.	DIRECTIVITY PATTERN	31
V.	CONCLUSIONS	33
	LIST OF REFERENCES.....	35
	INITIAL DISTRIBUTION LIST	37

THIS PAGE INTENTIONALLY LEFT BLANK

LIST OF FIGURES

Figure 1.	Basic MiniCan design, where \vec{P} is the Polarization vector in the ceramic.....	3
Figure 2.	MiniCan 1 self noise equivalent pressure compared with Wenz's minimum and Knudsen Sea State Zero.....	5
Figure 3.	Free-field voltage sensitivity of MiniCan 1 with the source incident perpendicular to the cylindrical axis.....	5
Figure 4.	Basic layout of MiniCan 6, showing the aluminum top body and cap, the two PZT discs and the copper foil at the center. The flexible preamp was folded inside the aluminum body.....	9
Figure 5.	Schematic of the flexible preamplifier used in the MiniCan design.....	12
Figure 6.	MiniCan modeled as a mass-loaded bar.....	12
Figure 7.	Graphical solution of transcendental equation for resonance frequency of MiniCan as a mass-loaded bar.....	13
Figure 8.	Resonance mode of interest in one of the aluminum parts.....	14
Figure 9.	Connecting cable internal layout, showing the possible air filled gaps.....	16
Figure 10.	Wiring of the Switchcraft Tini QG three pin male jack connector.....	17
Figure 11.	Dimensions of the Aluminum parts of MiniCan-7.....	18
Figure 12.	Aluminum parts of MiniCan-7 with PZT stack and the flexible preamplifier already mounted inside the base.....	19
Figure 13.	Assembled MiniCan-7 Hydrophone ready to start underwater measurements.....	21
Figure 14.	Resonance test device section.....	22
Figure 15.	Resonance test device assembled showing the attached cables.....	22
Figure 16.	Comparison of cable effects of measurements with and without cable for a single square 20 kHz pulse.....	24
Figure 17.	Comparison of cable effects of measurements with and without cable for a single square 50 kHz pulse.....	24
Figure 18.	Plot of the electrical admittance (Y) and phase (θ) of the first resonance of the resonance test device at 158.2 kHz.....	26
Figure 19.	Equivalent circuit plot for the first resonance of resonance test device, showing in plot E the corresponding circuit.....	26
Figure 20.	First resonance plot for the aluminum base using the resonance test device.....	27
Figure 21.	First resonance plot for the aluminum lid using the resonance test device.....	27
Figure 22.	Free Field Voltage Sensitivity combining two different sound sources and two different frequency ranges. Four different orientations relative to the incident sound are plotted.....	29
Figure 23.	Self Noise Pressure level of MiniCan-7 compared with Wenz's minimum and Knudsen Sea State 0.....	31
Figure 24.	Radiation pattern of MiniCan-7 at 10 kHz, 15 kHz, 20 kHz and 25 kHz.....	32

THIS PAGE INTENTIONALLY LEFT BLANK

LIST OF TABLES

Table 1.	Characteristics of MiniCan-2.....	4
Table 2.	Characteristics of MiniCan 3, 4 and 5.	7
Table 3.	Main Characteristics of MiniCan 6.....	9
Table 4.	Characteristics of MiniCan-7, before underwater measurements.....	20

THIS PAGE INTENTIONALLY LEFT BLANK

ACKNOWLEDGMENTS

I would like to express an eternal gratitude to all my professors during the two year sojourn at the Naval Postgraduate School, and above all to my thesis advisor Thomas J. Hofler, for his unconditional support, patience and clever guidance into the whole process of preparing this work. Thanks also to George Jaksha and Glenn Harrell for machining and modifying the different components used on the hydrophone and the resonance test device.

Also I want to express my admiration and most sincere acknowledgment to my wife Annalisa, who understood my long hours of absence also enduring my frustrations and sharing my success, and in some ways passed her pregnancy alone. Finally I want to recognize my sons Mario, Michele and the newborn Margherita for their tender and innocent view of life who was so inspiring in several steps during the writing of this thesis.

THIS PAGE INTENTIONALLY LEFT BLANK

LIST OF ABBREVIATIONS, ACRONYMS, SYMBOLS

ρ	Volume density
A_{MC}	Area of the MiniCan
APC	American Piezo Ceramics
A_{PZT}	Area of the PZT stack
B&K	Brüel & Kjær
FEA	Finite Element Analysis (software)
FFT	Fast Fourier Transform
\vec{g}_{ij}	Piezoelectric voltage coupling matrix (3x6)
ITC	International Transducer Corporation
JFET	Junction FET
NPS	Naval Postgraduate School
OCV	Open Circuit Voltage
PZT	Lead Zirconate Titanate
rHz	Square root of bandwidth in Hz
t	Thickness of the PZT
USD	United States Dollars
\vec{Y}_{ij}	Young's Modulus

THIS PAGE INTENTIONALLY LEFT BLANK

I. INTRODUCTION

A. BACKGROUND

Sound propagates energy in water much more efficiently than other types of transmitted energies, such as electromagnetic waves. Because of this, it has been used as the primary form of detection, communication and imaging underwater.

One of the most widely used mechanisms to achieve the transformation of acoustic energy into electric energy and vice versa is the piezoelectric transducer, which uses the piezoelectric characteristic of certain polarized ceramics. When an external electric field is applied to them, it produces an elastic strain, due to a change in polarization.¹ The most common piezoelectric ceramic used in underwater acoustics devices is the lead zirconate titanate, known also as PZT, thanks to its well balanced performance and low cost, and also because in the dynamic range in which it is employed it has a linear response.

Hydrophones are usually defined as devices that are used in a fluid media, in our case water, to convert acoustic energy into electric energy and vice versa. Although the term ‘hydrophone’ usually denotes a receiving mechanism, some of them can also be used as projectors, meaning that they can also convert electric energy into acoustic energy.²

A hydrophone must be able to detect weak signals in an ocean environment that may or may not be noisy, drive a cable long enough to reach the processing equipment and be simple enough to build so as to be competitive on the market. In order to fulfill the first two requirements, some hydrophones use a built-in internal preamplifier to improve its signal to noise ratio, which allows them to have a self noise pressure below the Knudsen Sea State Zero but usually above Wenz’s Minimum ocean noise. Wenz’s

¹ Oscar Brian Wilson, *Introduction to theory and Design of Sonar Transducers*, Peninsula Publishing, 1991, p.3.

² D. Stansfield, *Underwater Electroacoustic Transducers: a handbook for users and designers*, Bath University Press and Institute of Acoustics, 1990, p.2.

Minimum is a compilation of the lowest acoustic noise pressure spectral density values measured in the ocean, and published in the mid 20th century³.

In general, even though commercial hydrophones with a built in preamplifier fulfill all these requirements, their price is somewhat high, around \$2000 USD and their physical size is large with typical dimensions of 200 mm by 50 mm. This is the reason behind the study of a low cost, low noise and easy to build hydrophone with similar characteristics to the ones already on the market.⁴

B. PREVIOUS WORK ON THE MINICAN DESIGN

Previous work was initiated two years ago by two students who worked on the MiniCan design of a hydrophone, and the aim of this thesis is to try to improve the design and test it. The MiniCan's design consists basically of two rigid cylindrical parts made of aluminum 6061-T6 assembled one inside the other and separated by an annular gap of approximately 0.30 mm. Two simple piezoelectric disks are joined to a copper foil of 50 μ m in thickness by epoxy and mounted inside the aluminum parts. The design also houses a flexible preamplifier with ultra low self noise and the ability to drive a cable of around 6 meters.

The MiniCan Design was developed by Professor Thomas J. Hofler of the Naval Postgraduate School of Monterey, CA, although the design is roughly similar to the one described by Anan'eva in 1965.⁵ Construction and experimentation has been performed by the NPS students Lt Stavros Polydorou of the Hellenic Navy and Lt Miguel Alvarado J. of the Mexican Navy. These two students developed some theoretical descriptions of the design's performance, and built and tested several devices, named MiniCan 1 through 6.

³ Wenz Gordon M., *Acoustic Ambient Noise in the Ocean: Spectra and Sources*, J. Acoustics. Soc. Am. 34, 1962.

⁴ Such as Brüel & Kjær B&K 8103 costing \$1816 USD, B&K 8106 costing \$3275 USD or Sensor Technology SQ 03 with SA 03 preamplifier costing \$ 600 USD

⁵ Alevtina Aleksandrovna Annan'eva, *Ceramic Acoustic Detectors*, translated from Russian, Consultants Bureau: New York, 1965

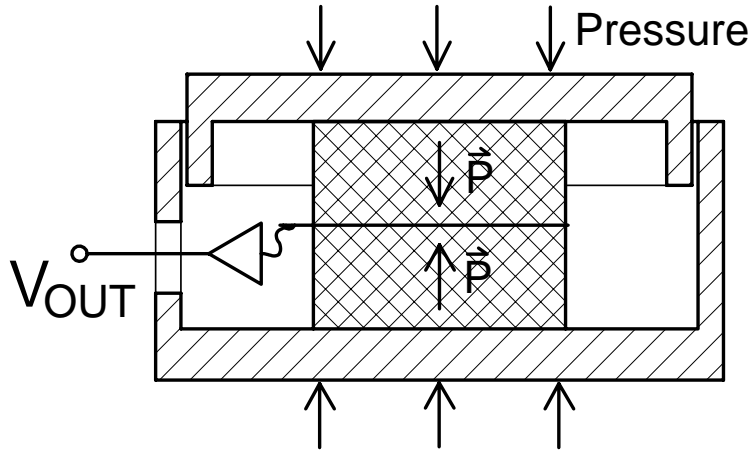

Figure 1. Basic MiniCan design, where \vec{P} is the Polarization vector in the ceramic.

1. Work Done by Lt. Stavros Polydorou

In his thesis, the initial assembly method was tested. The PZT, the copper foil between the two PZT disks, and the aluminum parts were all bonded together. Two hydrophones were built and tested. Of these only the first one had a built-in preamplifier. Moreover, the design of the preamplifier was tested and valuable lessons were learned which resulted in an improvement of the design in the following hydrophones.

In general, the work done by Lt. Polydorou demonstrated the possibility of designing and building a simple, compact and low-cost hydrophone relatively easily with a high sensitivity, and also self noise levels which are within a few decibels of the Wenz's minimum. The overall characteristics and performance achieved in his work are shown in Table 1. In Figures 2 and 3, we can observe the overall performance achieved by Lt. Polydorou in the first MiniCan designs

Dimensions and Performance

External Aluminum dimensions	27.94 mm OD x 15,24 mm tall
External encapsulated dimensions	33.02 mm OD x 19.05 mm tall

Basic Performance

Mechanical Resonance	75 kHz (lowest resonance)
Frequency response	3 Hz to 12 kHz \pm 1.5 dB Omnidirectional
(Response is directional above 12 kHz)	1.5 Hz to 20 kHz +3/-10 dB Omnidirectional
	2 Hz to 20 kHz \pm 2 dB in Cylinder plane
Pressure sensitivity	-167.45 dB re 1 V/ μ Pa
Equivalent pressure noise at 1 kHz	29.5 dB re 1 μ Pa/Hz ^{1/2} (In air)
Equivalent pressure noise at 10 kHz	19.1 dB re 1 μ Pa/Hz ^{1/2} (In air)
Maximum sensing pressure	610 Pa rms (Based on 2.6 Vrms max output)

Electrical Characteristics

DC Power supply	12 V
Preamplifier gain	18.73 or 25.45 dB
Equivalent input noise voltage at 1 kHz	1.67 nV/ Hz ^{1/2} (Input Shorted)
Output Impedance	67 Ω
Current consumption	3 mA
Maximum output signal level	1.85 Vrms
Maximum cable capacitance	2 nF (Max. Output Voltage at 10 kHz)

Table 1. Characteristics of MiniCan-2

In the next two figures we can observe the overall performance achieved by Lt. Polydorou in the first MiniCan designs.

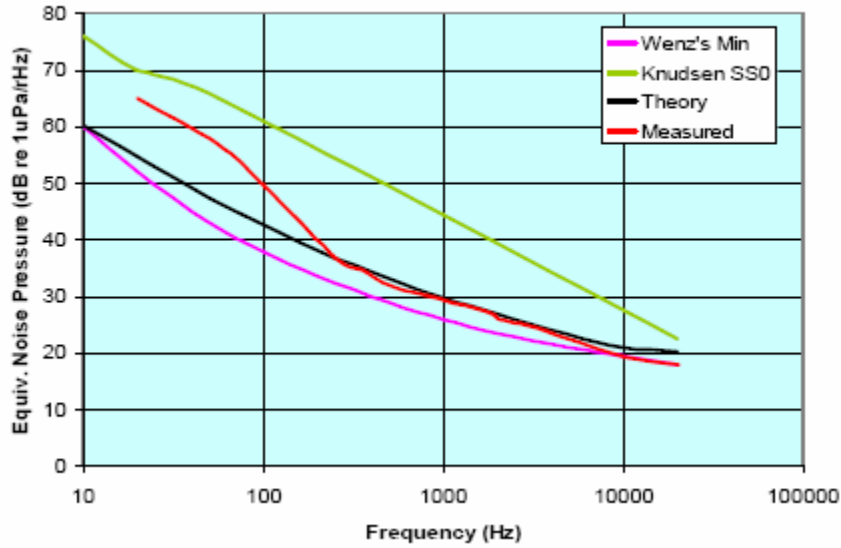

Figure 2. MiniCan 1 self noise equivalent pressure compared with Wenz's minimum and Knudsen Sea State Zero.

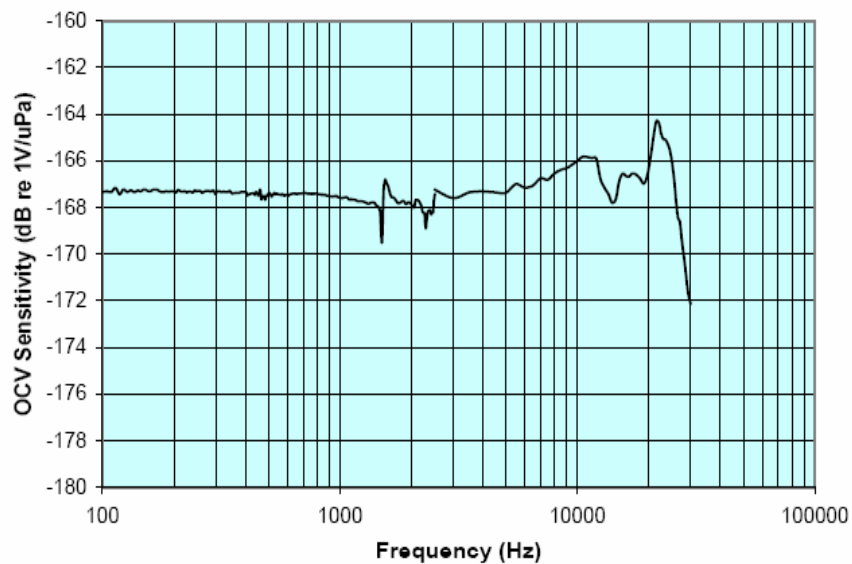

Figure 3. Free-field voltage sensitivity of MiniCan 1 with the source incident perpendicular to the cylindrical axis.

2. Work Done by Lt. Miguel Alvarado J.

Here further refinements were done to the hydrophone in order to improve its performance. In addition, a theory for predicting the mechanical resonances, self noise, and sensitivity were developed, achieving some valuable results.

The building process was changed, primarily in the way the ceramic, the copper foil and the aluminum caps were attached. The new technique used a two-part epoxy compound instead of soldering the parts, thus avoiding a possible depolarization in the ceramic. Some work was also done in refining the preamplifier design. This resulted in an improvement of the overall performance.

Lt. Alvarado built and tested 4 MiniCan hydrophones. Two of them were only test devices, but his final result was MiniCan 6, which presented the best characteristics of all of those designs.

The general description of MiniCan 6 will be presented in more detail in Section C, since it is the basis for the design of the hydrophone proposed and tested in this thesis. The general characteristics of MiniCan 3 through 5 are shown in Table 2.

	MiniCan 3	MiniCan 4	MiniCan 5
Outer Diameter of the Lid	13.82 mm	25.38 mm	25.30 mm
Interior diameter of the base	14.17 mm	25.91 mm	25.90 mm
Gap between base & lid	0.18 mm	0.26 mm	0.30 mm
Area ratio between average diameter & PZT	4.50	4.08	4.09
Mass of the lid and ground screw/cable	0.46 g	3.72 g	4.13 g
Mass of the base & 2 PZT stack	2.94 g	16.63 g	17.42 g (w/preamp)
Mass of the finished assembly		69.8 g	125.40 g
Capacitance of the PZT stack	298 pF	874.2 pF	515 pF
Gain of the built in preamplifier	15.51 dB	No Preamp	19.8 dB
Capacitance of the preamplifier	40 pF	No Preamp	52.70 pF
Theoretical Sensitivity before preamplification	-188.20 dB re 1 V/ μ Pa	-188.16 dB re 1 V/ μ Pa	-185.35 dB re 1 V/ μ Pa
Underwater measured Sensitivity	-174.6 dB re 1 V/ μ Pa	-189.80 dB re 1 V/ μ Pa	-171.07 dB re 1 V/ μ Pa
Intrinsic Pressure Sensitivity (at preamp. input) / Measures using a reference Accelerometer	-190.11 dB re 1 V/ μ Pa (Intrinsic)	-188.53 dB re 1 V/ μ Pa (Accelerometer)	-185.32 dB re 1 V/ μ Pa (Accelerometer)

Table 2. Characteristics of MiniCan 3, 4 and 5.

C. MINICAN 6

The first change Alvarado made in the design of MiniCan 6 was in the built-in preamplifier. This preamp has a single-ended input and output, consisting of an n-channel JFET front end, followed by an NPN emitter follower stage providing low output impedance. The bias current at the JFET gate is roughly 1 pA, with a negligible input noise current.

The preamp is protected at the gate by a pair of diodes to limit high fluctuating voltages produced in the ceramic due to rough handling of the hydrophone or massive underwater pressure fluctuations. A 1 G Ω resistor is connected between the gate and ground to maintain a nearly zero DC bias voltage at the gate.

It has an extremely low equivalent input noise voltage, a voltage gain of 18.03 dB and an input capacitance of 51.4 pF, but has limited input voltage range and output current. The power supply is provided by a 12 V battery.

Since the preamplifier components are mounted on a flexible printed circuit board (PCB), it can be safely bent in order to fit in a very small space, thus permitting the use of this very low noise design in a small hydrophone. Another feature was the internal shape of the aluminum housing parts, providing the body and the lid with a raised circular step with same dimensions as the ceramic discs. This was done to reduce the constraints of the PZT in the radial direction in order to increase the sensitivity of the hydrophone.⁶

The two ceramic discs used were made of American Piezo Ceramics 840 (APC-840) equivalent to Navy Type I, each one measuring 6.60 mm x 3.43 mm in diameter and thickness, respectively. The ceramic polarizations are oriented anti-parallel and the capacitive discs are electrically connected in parallel.

⁶ This was demonstrated by Lt. Miguel Alvarado in his thesis *Construction and testing of low-noise hydrophones*, 2003, p 37.

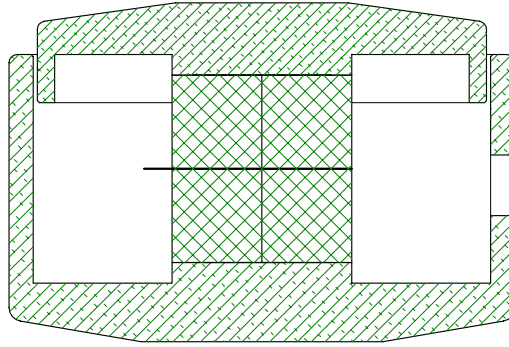

Figure 4. Basic layout of MiniCan 6, showing the aluminum top body and cap, the two PZT discs and the copper foil at the center. The flexible preamp was folded inside the aluminum body.

This design proved to have a low frequency sensitivity of -168.0 dB re $1\text{V}/\mu\text{Pa}$ and a very flat response of up to about 14 kHz. It also proved to have an outstanding noise performance beating the Wenz’s minimum in the entire spectrum, except about 25 kHz where it had its mechanical resonances. The overall characteristics of MiniCan 6 are shown in the Table 3.

Outer diameter of the lid	16.54	mm
Interior diameter of the base	16.88	mm
Annual gap between base & lid	0.17	mm
Area ratio between average diameter & PZT	6.27	–
Mass of the lid & ground cable	1.19	g
Mass of the base, 2 PZT stack & electronic comp.	4.55	g
Mass of the finished assembly w/ urethane	63.65	g
Capacitance of the PZT stack	200.	pF
Capacitance of the built-in flexible preamp	51.4	pF
Gain of the built-in flexible preamp	18.03	dB
Theoretical sensitivity + preamp gain	-166.5	dB re $1\text{ V}/\mu\text{Pa}$
Underwater Measured Pressure Sensitivity	-168.0	dB re $1\text{ V}/\mu\text{Pa}$

Table 3. Main Characteristics of MiniCan 6.

THIS PAGE INTENTIONALLY LEFT BLANK

II. SCOPE AND MOTIVATION

A. THEORY BEHIND THE MINICAN DESIGN

As described before, the MiniCan design consists of two rigid aluminum cylindrical parts mounted one inside the other. Each of these parts has a ceramic disk attached to it, which in turn are joined back to back by means of a thin copper foil. The ceramic disks must be back to back in order to receive the forces applied in the direction of their polarization (the 3-axis direction) so as to generate a positive voltage. The copper foil provides a wire attachment point for sensing the voltage of both ceramic disks.

Moreover, since the area of the aluminum parts exposed to water is much greater than the area of the ceramics, the design also exploits the beneficial effects that the ratio between these areas has on sensitivity, given by the expression⁷

$$\text{OCV}_{PZT} = \left(\frac{A_{\text{MiniCan}}}{A_{PZT}} \right) g_{33} t \quad , \quad (2.1)$$

where A_{MiniCan} represents the effective piston area of the hydrophone in contact with water in the 3-direction, and A_{PZT} is the cross sectional area of the ceramic disk.

The copper foil is directly connected to the flexible preamplifier input, whose basic layout is in the following figure,⁸ which was described in Chapter I.

⁷ Stavros Polydoprou, *A compact and inexpensive Hydrophone Having Ultra Low Self-Noise*, NPS thesis, 2002, p 12-13.

⁸ Stavros Polydoprou, *A compact and inexpensive Hydrophone Having Ultra Low Self-Noise*, NPS thesis, 2002, p 26.

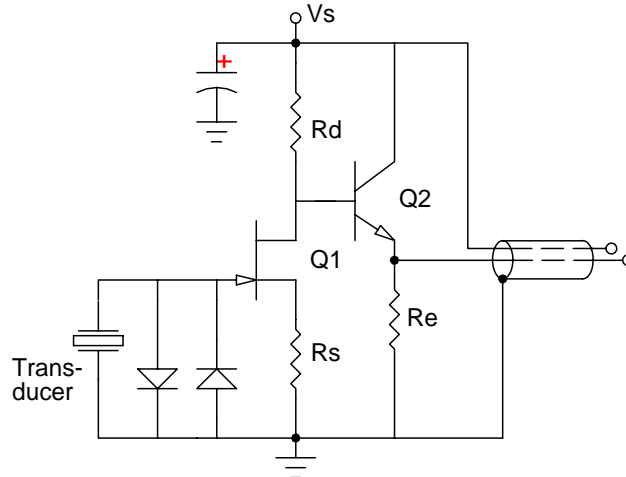

Figure 5. Schematic of the flexible preamplifier used in the MiniCan design.

B. UNDERSTANDING THE COMPONENT'S RESONANCES

The sensitivity response of the hydrophone was discovered to be influenced by the mechanical resonances of the assembled hydrophone; and only very simple theories have been developed to attempt to calculate them. In fact, trying to model a complex structure like the MiniCan hydrophone, with two ceramic disks inside a two-part aluminum body, was enough work for an entire new thesis. As an example, this modeling was attempted by Adam Akif, an NPS student using FEA software called Abacus. In spite of considerable experience with the software and months of part-time work on the model, he could not finish it before graduating.

Some basic theory has already been implemented. Lt. Alvarado developed an analysis of the MiniCan as a PZT bar with two masses corresponding to the lid and base.⁹

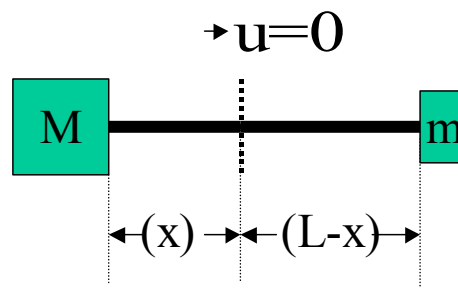

Figure 6. MiniCan modeled as a mass-loaded bar.

⁹ Miguel Alvarado J., *Construction and testing of low-noise hydrophones*, NPS thesis, 2003, p 6-8.

The analysis gave a transcendental equation, which can be solved graphically,

$$kL = \tan^{-1}\left(\frac{m_b}{m} \frac{1}{kL}\right) + \tan^{-1}\left(\frac{m_b}{M} \frac{1}{kL}\right), \quad (2.2)$$

where m_b and L are the mass and length of the PZT stack, m is the mass of the lid and M is the mass of the base. The first resonance frequency can be obtained from the solution to Eq. (2.2) and the relationship

$$f = \frac{\sqrt{\frac{Y_{33}}{\rho}}}{2kL} kL, \quad (2.3)$$

where Y_{33} is the Young's modulus and ρ the density of the PZT.

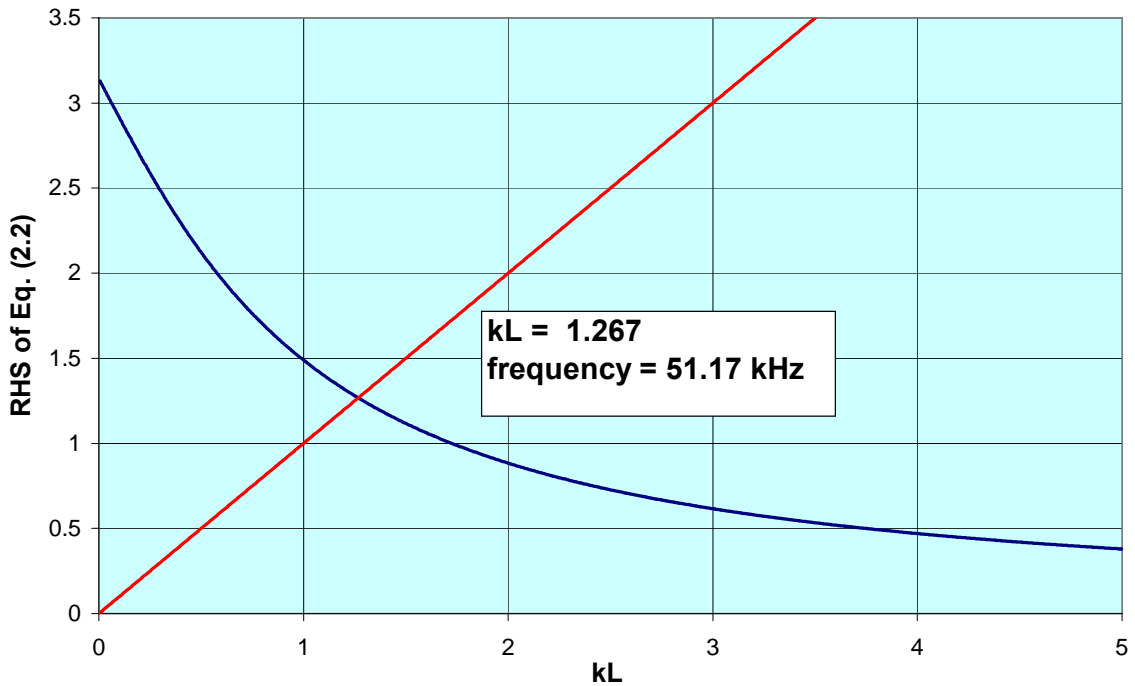

Figure 7. Graphical solution of transcendental equation for resonance frequency of MiniCan as a mass-loaded bar.

The resonance frequency obtained using this theory was 51.17 kHz.

In previous work on the MiniCan hydrophone, the results of the above resonance model proved to yield a much higher resonant frequency than the measured first resonant

mode of the hydrophone. Thus, the above model was useful only to the extent that it allowed this obvious mode of vibration to be excluded from consideration when attempting to determine the cause of the first resonance.

However, it was expected that the resonances affecting the performance of the hydrophone would be those of the aluminum housing parts, since they are likely lower in frequency. But what mechanical resonances of the housing would be the ones of interest?

First, the direction of the oscillations should be in the 3-direction, which is the motion the ceramic is sensing. The geometry of the cylindrical aluminum body is made more complex by the fact that the interior has a step or “pad” where it is bonded to the ceramic. A simplified approach would be to consider a flexural oscillation of the base of the housing cylinder, and a possible longitudinal oscillation propagating tangentially in its cylindrical wall. Those are likely to be the modes affecting the performance of the hydrophone, although the cylindrical oscillation is likely to be weakly coupled to the sensing direction of the PZT.

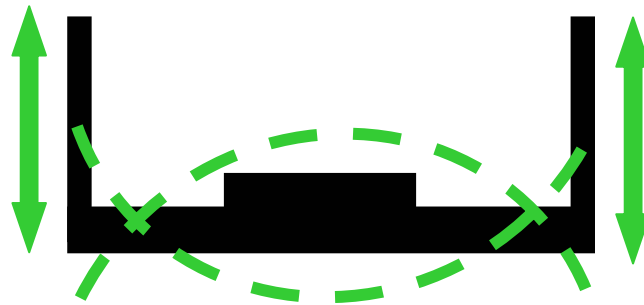

Figure 8. Resonance mode of interest in one of the aluminum parts

In order to determine the effect of these mechanical resonances and try to improve the design for future work, a different approach was attempted. Instead of modeling the resonances of the hydrophone or its components, a device was constructed to test the

component resonances. Admittedly, the results would be an approximation since finding the resonances of the components would not necessarily give the completely assembled hydrophone spectrum.

In addition, these tests were conducted in air and the resonances measured will not reflect the mass loading effect of the urethane coating or the water mass present in actual hydrophone use. However, once the hydrophone is fully assembled it could not be tested as a passive electrical device to find mechanical resonances due to the fact that it possesses an internal preamplifier.

Still, it was expected to be determined how the components influence the overall behavior of the assembled device, so that a comparison of the results with the sensitivity measurements in water and the self noise in the anechoic chamber could be made. A surprising result of the self noise measurements is that they clearly exhibit some of the mechanically resonant modes, as shown later. The characteristics of the resonance tester device will be described in Chapter III.

C. MOTIVATION FOR A NEW DESIGN

The design can be improved if the aluminum parts are modified. This was the motivation for building MiniCan 7. It was expected to increase the flat response region in the sensitivity curve, increasing the lowest resonance of the aluminum components. To achieve these results, the bottom of the aluminum parts was thickened to increase their flexural stiffness, and the walls were made thinner in order to reduce the mass loading of the outer edge of the aluminum disc.

D. AN UNANSWERED QUESTION

Additional experimentation was attempted to determine the effect that the cable had on the overall sensitivity of the assembled hydrophone in order to understand and possibly correct the effect it has on the underwater measurements. The concern about the cable was due to the fact that some air can get trapped inside it since there is no filling between the conductor cables and the external jacket.

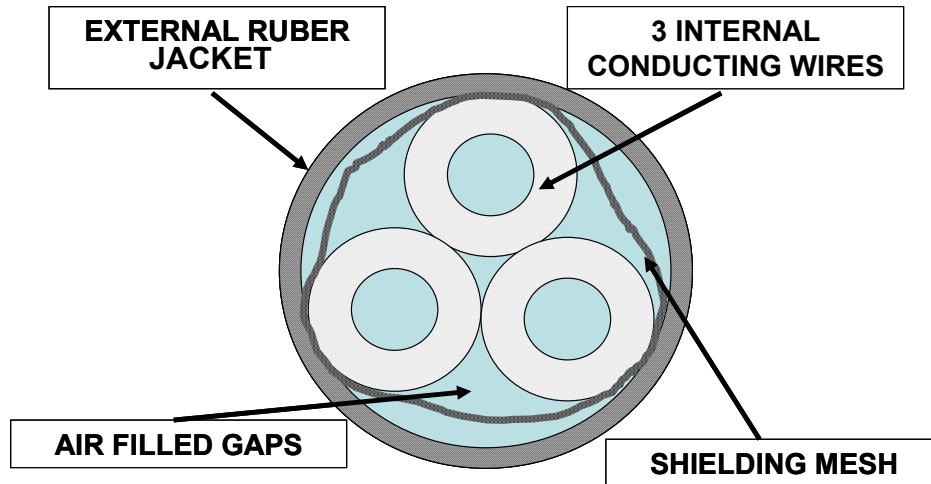

Figure 9. Connecting cable internal layout, showing the possible air filled gaps.

The potential problem with the cable is that the specific acoustic impedance of water is a few orders of magnitude higher than that of air. While the net acoustic impedance of the outer surface of the cable is likely to be much higher than air, it may still be considerably lower than that of water, which could greatly increase its acoustic scattering cross-section in certain frequency ranges.

To assess the effects, an experiment was designed to measure the real effect that the cable had on the overall sensitivity of the hydrophone. This experiment will be described in Chapter IV.

III. CONSTRUCTION

A. CABLE PREPARATION

A shielded two-conductor Daburn 2678 cable was used for MiniCan-7 with a total length of 6.10 meters. One end was connected to the built-in flexible preamplifier, and the other end was soldered to a Switchcraft Tini QG three pin hydrophone cable connector, which was wired according to the following diagram.

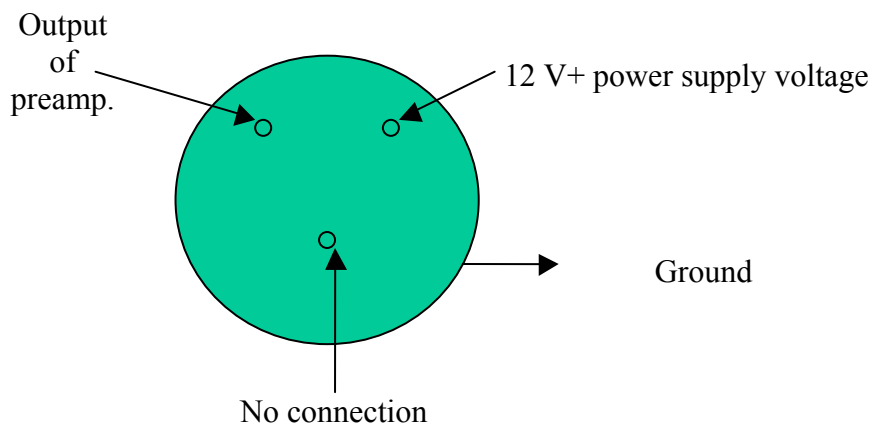

Figure 10. Wiring of the Switchcraft Tini QG three pin male jack connector

To couple this connector to other instruments, it is necessary to use a 27 x 35 x 57 mm junction box, provided with a three pin connector, a DC power jack and a male BNC output connector. The end of the cable connected to the hydrophone was backfilled with silicon rubber GE RTV-615A compound. The process of applying the silicon rubber was done in a vacuum chamber in order to suck the liquid rubber into the cable when exposed to the atmosphere. This process achieved a filling of about 60 centimeters, measured from the end of the cable.

B. CONSTRUCTION OF THE HYDROPHONE

The metal parts were machined in 6061-T6 aluminum having an outer nominal diameter of 18.07 mm. The mass of the base is 2.66 g and the mass of the lid is 1.43 g, the overall dimensions and the general layout are shown in the following figure.

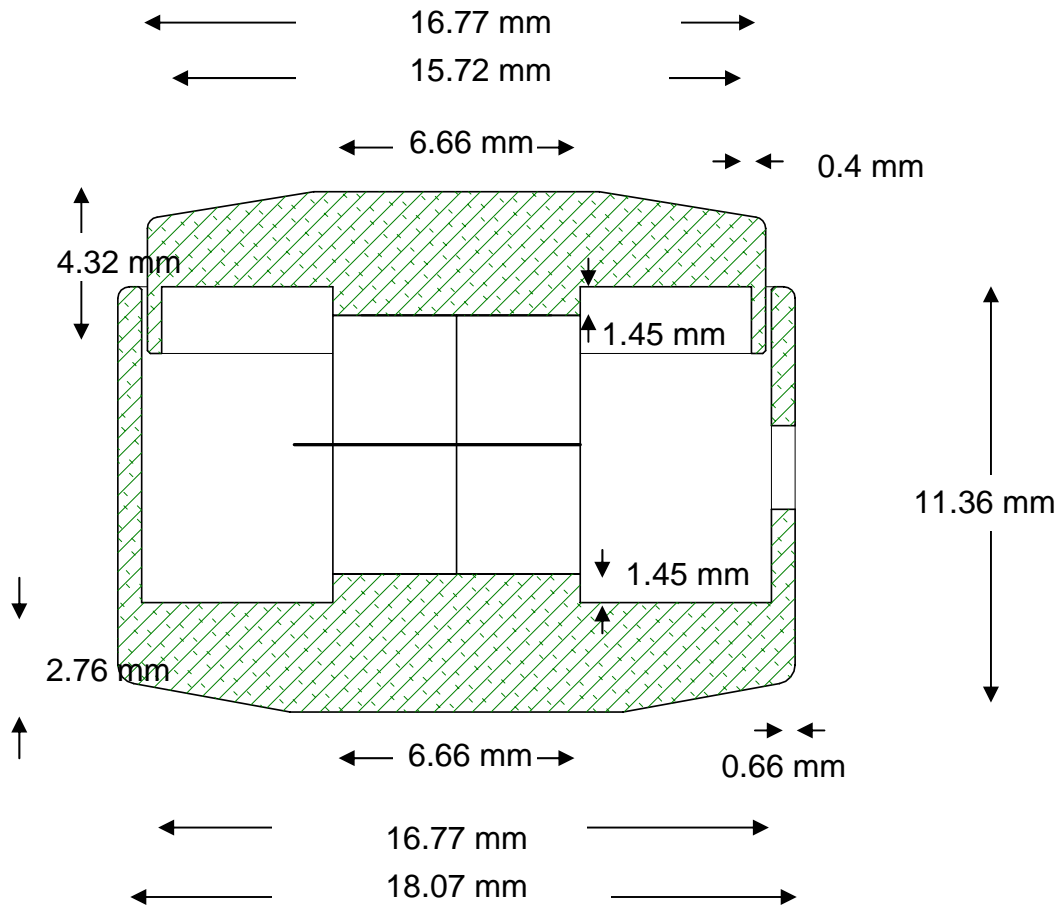

Figure 11. Dimensions of the Aluminum parts of MiniCan-7

The two ceramic parts are APZ-840, or Navy Type I, disks with a diameter of 6.60 mm, a height of 3.43 mm and a mass of 0.89 g each. They were glued to the 50 μ m copper foil with a 2 part epoxy Emerson & Cummings 1266, thus forming a sandwiched stack. A small amount of solder was deposited on the tab of the copper foil in order to facilitate the connection with the preamplifier.

The PZT stack was then attached to the aluminum base using an Emerson & Cummings 1266 epoxy compound, and was left to cure overnight. To ensure that the ceramic parts and their base at the bottom of the aluminum cylinders were properly aligned, a specially designed aluminum alignment tool was used.



Figure 12. Aluminum parts of MiniCan-7 with PZT stack and the flexible preamplifier already mounted inside the base.

Next, the flexible preamplifier was inserted inside the aluminum base and glued to its walls with a 5 minute epoxy and its input cable was soldered to the copper tab of the PZT stack. The preamplifier used was selected from a previously built lot, and after measurements it proved to have a total capacitance C_p of 52.4 pF and a Gain of 10.05.

When installing the cable, the end filled with silicon rubber was peeled from the jacket, separating the output internal wire, the 12 V power supply wire and the shielding drain wire. The wire was introduced into the hydrophone opening and was fixed in place using 5 minute epoxy. Then, a coating of Devcon Flexane 94 polyurethane compound was applied to the cable and to the opening primarily to strain relieve the junction and also to make it watertight. To ensure a common ground, a small hole was drilled on the

bottom of the base in order to attach the ground wire of the preamplifier with a screw, the shielding mesh of the cable and a small wire which was connected to the lid with silver epoxy.

Once all the internal components were in place, the lid was attached to the top of the PZT stack using the Emerson & Cummings 1266 epoxy compound, and once cured, the annual gap between the aluminum parts was sealed using the very soft silicon rubber GE RTV-615A. Finally, the unit was encapsulated using Devcon Flexane 80 polyurethane compound with a Flex-Add additive to soften the cured material.

Once cured, the assembled MiniCan-7 hydrophone has an average diameter of 20.57 mm, an average height of 18.51 mm, with a mass of 8.69 g without cable. The following table is a summary of the overall characteristics.

Outer diameter of the lid	16.52	mm
Interior diameter of the base	16.77	mm
Gap between base & lid	0.12	mm
Area ratio between piston diameter & PZT	6.37	
Mass of the lid & ground cable	1.43	g
Mass of the base and PZT stack	4.45	g
MiniCan-7 piston diameter	16.67	mm
MiniCan-7 height	18.51	mm
MiniCan-7 mass without cable	8.69	g
Preamplifier Capacitance	52.40	pF
Preamplifier Gain	10.05	20.04 dB

Table 4. Characteristics of MiniCan-7, before underwater measurements.



Figure 13. Assembled MiniCan-7 Hydrophone ready to start underwater measurements.

C. CONSTRUCTION OF THE RESONANCE TESTING DEVICE

The resonance test device consists of a single PZT disk with an attached top disk of Aluminum with a mass of 0.13 g, and a semi-conical body of stainless steel with a mass of 3.77 g, attached to its bottom. Both metal parts have a slotted surface in contact with the ceramic to allow radial strains. The PZT disk used is the same as one of the two disks used in the hydrophone construction.

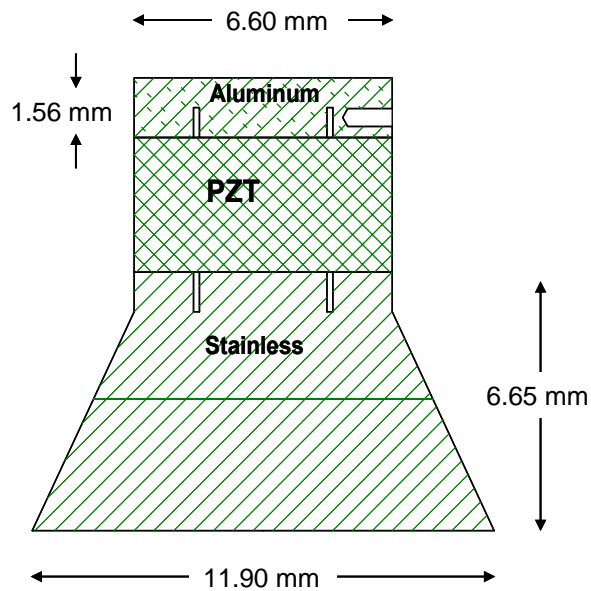

Figure 14. Resonance test device section.

In order to measure resonances with the HP4194A impedance analyzer, 2 wires were cut with a total length of 250 mm. One was attached to the stainless steel body using solder, and the other was attached to a small hole drilled in the aluminum part for that purpose using silver epoxy. The 3 main parts were put together using Emerson & Cummings 1266 epoxy. Once cured, the wires were wrapped on the bottom part and were covered with a small amount of 5-minute epoxy in order to keep them in place and prevent detachments. Once assembled, the device had a mass of 4.65 g.

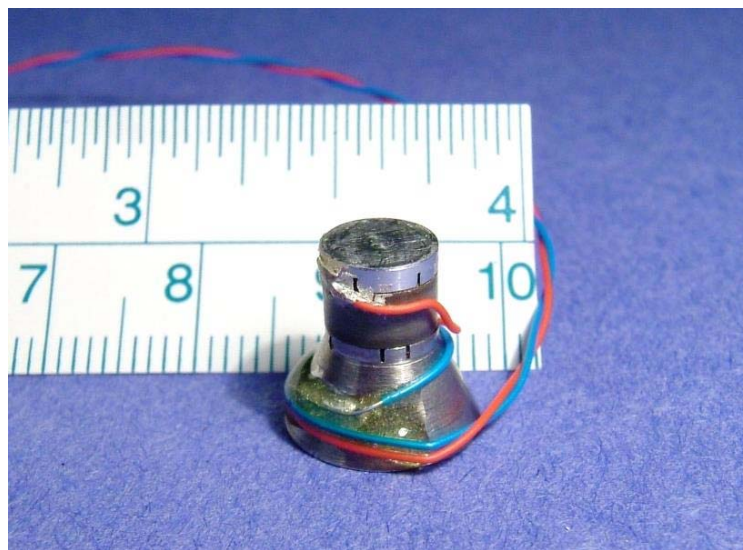

Figure 15. Resonance test device assembled showing the attached cables.

IV. MEASUREMENTS AND DISCUSSION

A. ACOUSTIC EFFECT OF CABLES

To assess the effects of the cable, a comparison calibration method was employed. Two B&K 8103 hydrophones were used which possess a very good calibration chart.¹⁰ These hydrophones have a very flat response up to about 45 kHz, and are quite omnidirectional in the frequency range of interest.

The test was conducted in the water tank facility of the NPS. The two B&K hydrophones were located about 30 cm apart and an ITC-1032 spherical projector with a resonance frequency of 33 kHz. was used. The projector was driven by a signal generator. The hydrophones output signals were preamplified by a pair of Stanford SRS560 low noise preamplifiers, which in turn were connected to a Stanford SR785 Dynamic Signal Analyzer.

To eliminate the effects of an acoustical reverberant water tank, an impulse FFT method with Hanning windowing was used. The impulse signals generated to assess the effect were a single sine pulse for frequencies below 20 kHz and a single square pulse for higher frequencies.

First, a set of measurements was performed with just the two B&K hydrophones alone, and then a piece of Daburn 2678 shielded two-conductor cable, which was sealed at both ends, was placed alongside one of the hydrophones resting at a distance of about 3 cm from the hydrophone, and maintained parallel to it by a lead weight. Measurements were made with the projector emitting pulses of 2.2, 20, 33, 50 and 70 kHz. The difference was then taken between the results with and without the cable, over the frequency range of interest (up to 50 kHz).

¹⁰ The Hydrophones were B&K 8103 S/N 1406210 with a OCV Sensitivity of -212.2 dB re 1V/ μ Pa; and S/N 2241680 with a OCV Sensitivity of -221.7 dB re 1V/ μ Pa.

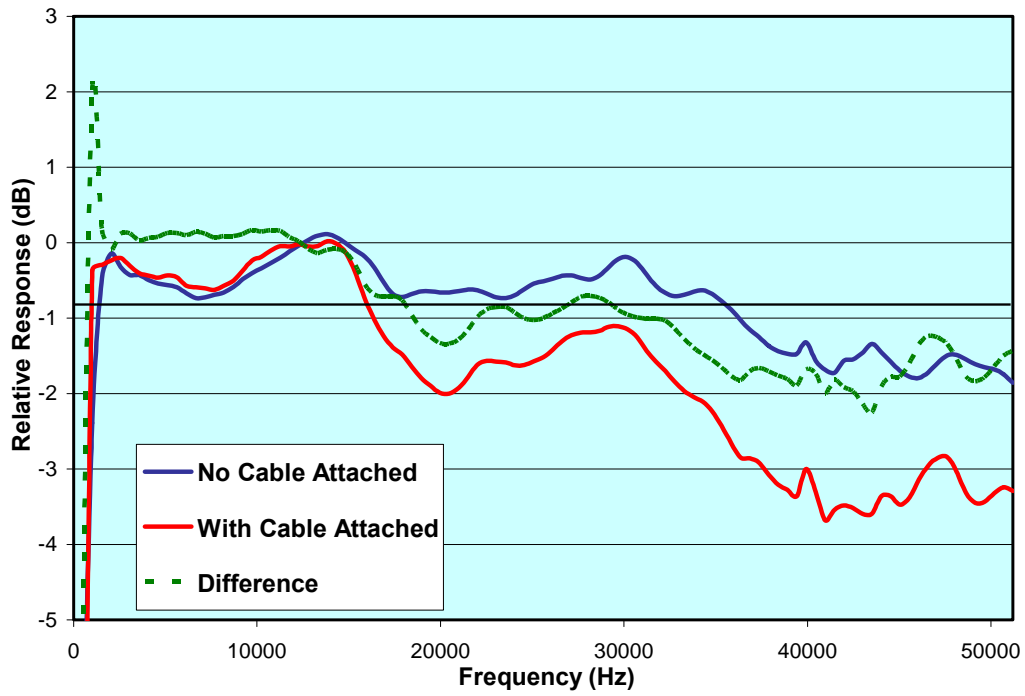

Figure 16. Comparison of cable effects of measurements with and without cable for a single square 20 kHz pulse.

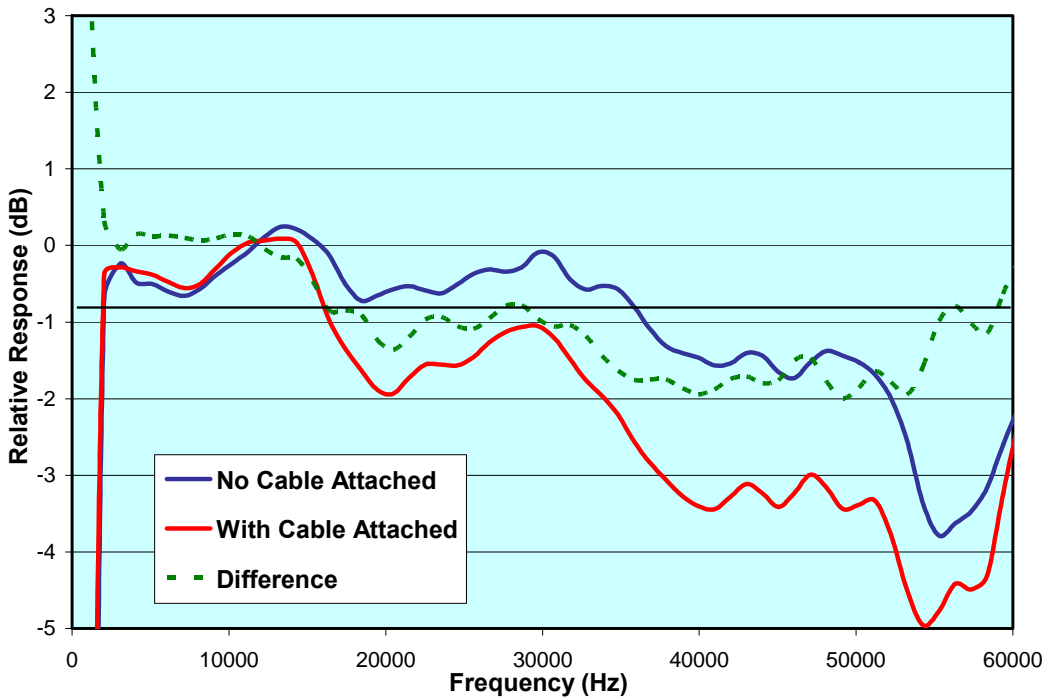

Figure 17. Comparison of cable effects of measurements with and without cable for a single square 50 kHz pulse.

The large data variations below 2 kHz usually arise from very low frequency noise or spurious voltage offsets caused when receiving the impulse, and are not meaningful. From the measurements, it can be seen that the effect of the cable on the overall performance of the hydrophone is about 1 to 2 dB for frequencies above 15 kHz, which is small but possibly non-negligible.

B. RESONANCE TESTS RESULTS

The measurements with the resonance test device were conducted using the HP 4194A Impedance Analyzer. The two wires of the resonance test device were connected to the input A channel, and measurements were made to determine the mechanical resonances of the parts under test, using plots of Admittance Y and Phase θ , or plots of Susceptance G and Admittance B . Also the feature of determining an equivalent circuit of the Y versus θ plot was used to verify the validity of the test. To test the different components, these were attached to the aluminum top of the resonance test device using super glue.

The first test done was to the resonance test device itself. First, the lowest resonance of the device was determined, and then using the equivalent circuit feature the electromechanical coupling coefficient was calculated using the expression

$$k^2 = \frac{C_M}{C_o + C_M}, \quad (4.1)$$

where C_M is the motional capacitance of the device. In the equivalent circuit figure, this appears as C_b , and C_o is the blocked capacitance of the device, which is C_a in the equivalent circuit figure minus the capacitance of the wires of the device.¹¹

The values obtained were: the first resonance of the device was 158.2 kHz, $C_M = 18.2 \text{ pF}$, $C_o = 87.7 \text{ pF}$, and the electromechanical coupling coefficient was $k = 0.415$. This last value, as expected, is lower than the manufacturer's value for the PZT, but acceptable for our purposes.

¹¹ The capacitance of the cables of the resonance test device was measured to be 14.9 pF.

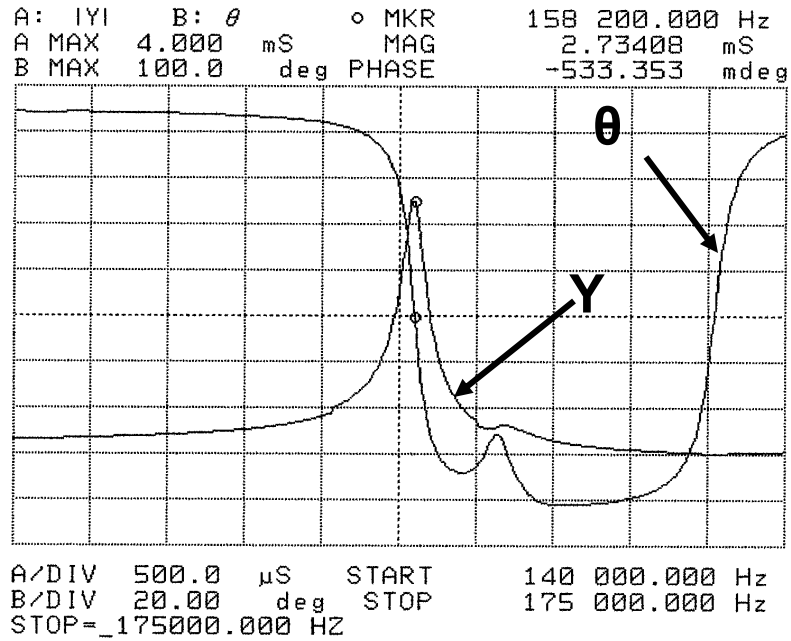

Figure 18. Plot of the electrical admittance (Y) and phase (θ) of the first resonance of the resonance test device at 158.2 kHz.

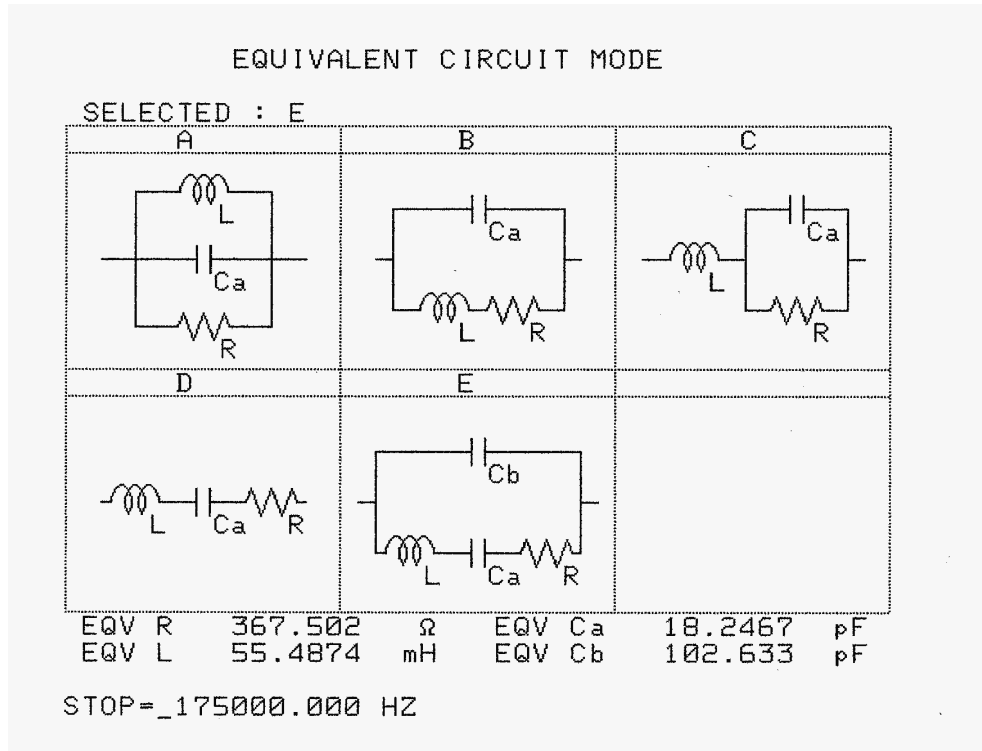

Figure 19. Equivalent circuit plot for the first resonance of resonance test device, showing in plot E the corresponding circuit.

Next, the first resonances of the aluminum lid and base were investigated, gluing them to the top of the device. The corresponding resonances obtained were 46.58 kHz for the lid and 34.625 kHz for the base, and as suspected they were lower than the 51.17 kHz obtained for the mass-loaded bar theory.

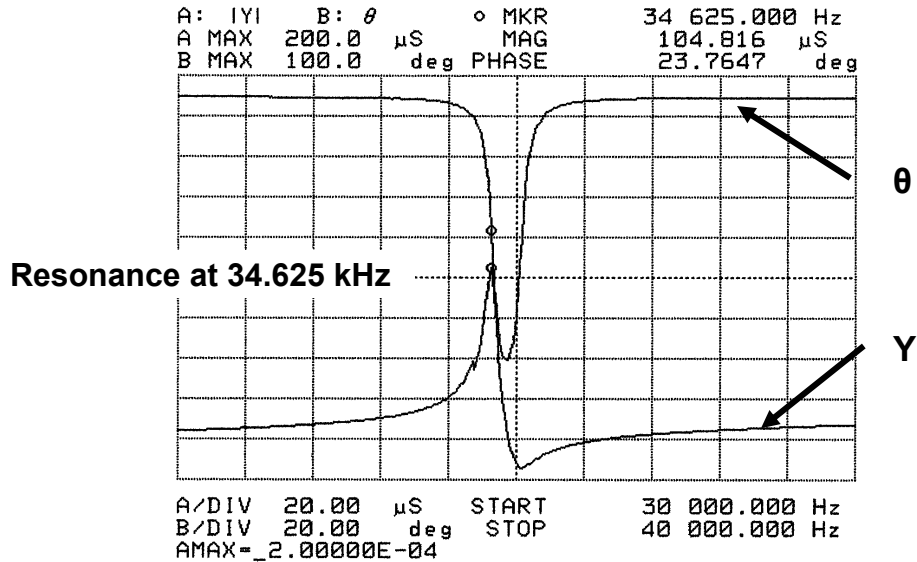

Figure 20. First resonance plot for the aluminum base using the resonance test device.

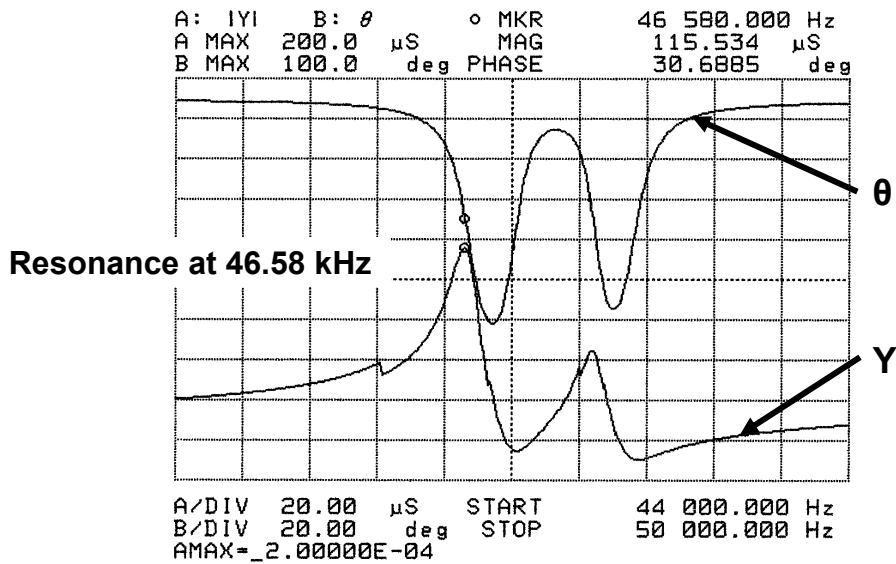

Figure 21. First resonance plot for the aluminum lid using the resonance test device.

C. FREQUENCY RESPONSE OF SENSITIVITY

To assess the pressure sensitivity of MiniCan-7, an underwater comparison calibration was made in the acoustics measurements water tank of the NPS. Two distinct set of measurements were made, one for low frequency using OCV measurements and one for high frequency using a free field measurement.

The calibration method consisted of comparing the signals of the device under test with those of a known, reliable and well-calibrated hydrophone. Both are placed equidistant to a source and their signals are sent to a Stanford SR785 Dynamic Signal Analyzer. This performs a two-channel frequency response measurement, either using a Sweep Sine analysis for LF, or an impulse FFT analysis for Mf or HF.

The high frequency calibration was done using a B&K 8103 hydrophone¹² connected to a Stanford SR560 low-noise preamplifier as a reference receiver and a spherical ITC-1032 projector as a source.¹³ The ITC projector was driven by a Stanford DS345 function generator with single sine pulses of frequencies varying from 2.5 kHz to 40 kHz. The signal analyzer was set to use a FFT impulse frequency response measurement using 100 lines, 64 FFT averages, and frequency spans from 0 to 25.6 kHz or 51.2 kHz depending on the projector frequency. Also, the triggering time delays were set to eliminate the effect of the pulses reflected from the walls or surface of the tank, and measurements were made with 4 different orientations of the hydrophone under test, namely with the lid axis pointing towards and opposed to the projector, and both broadsides.

In this case the hydrophones were separated from each other by 20.7 cm and from the projector by 75.5 cm. The distance between the hydrophones in this case is sufficient to minimize interference between themselves due to acoustic scattering. The response of the device under test is compared to a ‘free acoustic field’ pressure stimulus, due to the omnidirectionality of the projector in the frequency range used, and because the reference hydrophone is known to have a flat free field response. Thus the calibration is of the type ‘Free Field Voltage Sensitivity’ or FFVS.

¹² B&K 8103 S/N 2241680 with an OCV Sensitivity of -211.7 dB re 1V/ μ Pa.

¹³ ITC-1032 S/N 1097, Omnidirectional up to 45 kHz.

For the low frequency calibration, the same reference hydrophone was used, but the source was changed to a Dual Tri-Laminar Flexural Disk Projector with a very low resonance frequency.¹⁴ The hydrophones were placed very close to each other, without contact, to take advantage of the fact that at lower frequencies the wavelength is very big, so there is very little variation between what both hydrophones are sensing. This type of calibration is named OCV sensitivity, and since a sweep sine signal from 100 Hz to 1 kHz was used, diffraction effects are negligible due to the small size of the hydrophones. The data collected from these measurements is condensed in the following figure.

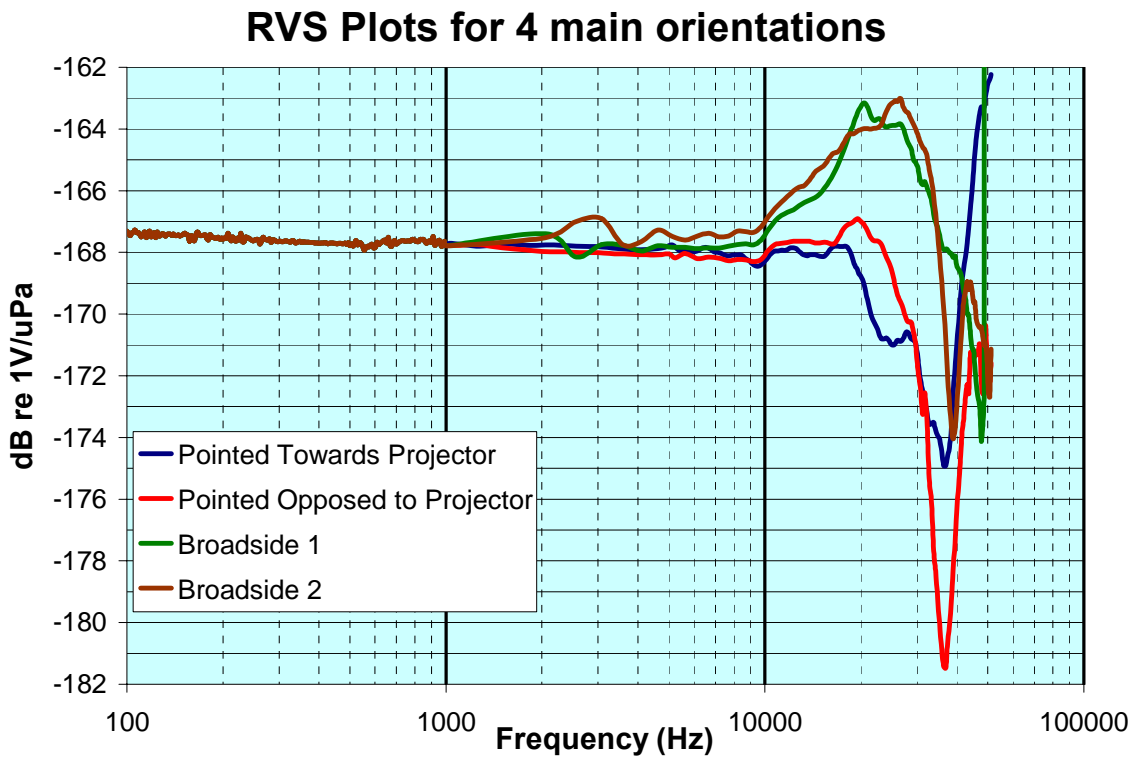

Figure 22. Free Field Voltage Sensitivity combining two different sound sources and two different frequency ranges. Four different orientations relative to the incident sound are plotted.

From the data generating the above figure, the low frequency sensitivity for MiniCan-7 was measured to be -167.8 dB re 1V/ μ Pa, which is only 1.0 dB lower than the

¹⁴ DTLFDP-2 was built by Lt Steve Rumph USN, Lt Rob Hill USN and Adam Akif as a project in the PH4454 course, the disk projector has a resonance frequency in water of 1150 Hz.

value predicted by theory. Also, the increase in the flat response frequency range is clearly appreciated if compared with MiniCan-6, which is now about 30 kHz compared to 21 kHz with MiniCan-6. The first resonance of MiniCan-7 underwater is about 35 kHz compared to 22 kHz for MiniCan-6.

D. NOISE PERFORMANCE

This measurement was made in the anechoic chamber facility of the NPS, and it was conducted in order to assess the self noise level of MiniCan-7. The hydrophone was mounted on a mechanical filter designed by Prof. Hofler and used previously by Lt. Alvarado, consisting of a 2 kg square section steel bar suspended from the ceiling of the anechoic chamber by a set of rubber bands. This device has a natural frequency of 0.75 kHz.

Since the intended measurement is of the noise generated by the hydrophone itself, no source was needed. In order to minimize the environmental noise, the measurements were made late at night. In addition, to minimize the effects of the power supply 60 Hz harmonics, the output of MiniCan-7 was connected to a SR560 low noise preamplifier operating on batteries only.

The output of the preamplifier was connected to a SRS785 signal analyzer in order to measure the noise power spectral density in dB re $1V/\sqrt{\text{Hz}}$. The resulting data was compared with noise levels of Knudsen Sea State Zero and with the lowest underwater noise reference known as Wenz's minimum.

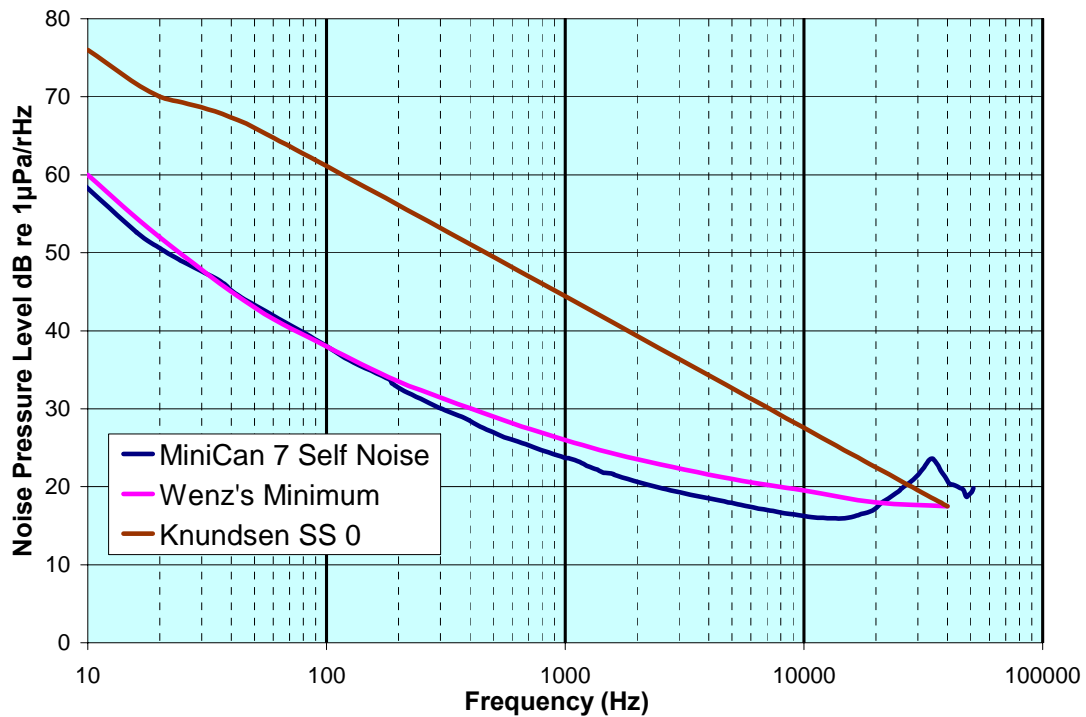

Figure 23. Self Noise Pressure level of MiniCan-7 compared with Wenz’s minimum and Knudsen Sea State 0

The outstanding noise performance of the MiniCan design can be clearly appreciated since, as with MiniCan-6, MiniCan-7 beats Wenz’s minimum noise level up to about 20 kHz. Moreover, from this plot it can be recognized that a resonance occurs at 34.6 kHz, which is within 0.2 % of the mechanical resonance of the base measured with the resonance test device. Since both measurements were made in air, this agreement gives an interesting result in understanding the mechanical behavior of the MiniCan design.

E. DIRECTIVITY PATTERN

This measurement is quite similar to the high frequency free field voltage sensitivity measurement discussed above. The main difference consists in the fact that MiniCan-7 is mounted on a rotating rod, whose motor is connected to a laptop computer to control its rotation. Also, an output of the SR785 signal analyzer is connected to the

same laptop computer where, by means of software, the output of the impulse FFT analysis is recorded versus the angle of rotation.

Measurements were made at various frequencies, driving the projector with a two cycle sine signal, and the following radiation patterns were obtained. It is clear that the uniformity of the directivity pattern decreases as the frequency increases, which might be partially explained by the fact that the urethane encapsulation of the hydrophone is not uniform, having some visible bumps.

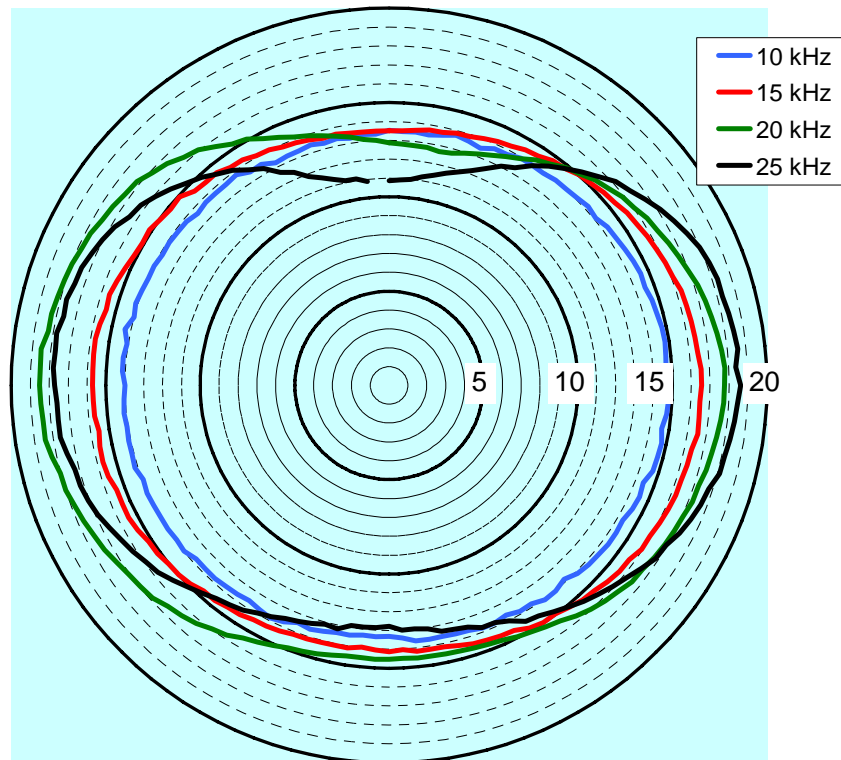

Figure 24. Radiation pattern of MiniCan-7 at 10 kHz, 15 kHz, 20 kHz and 25 kHz.

V. CONCLUSIONS

The modifications made to the aluminum parts used in the hydrophone in order to increase the frequency of the mechanical resonances proved to be successful in improving the performance of the hydrophone. The increase of the lowest mechanical resonance device resulted in an extension of the flat response region of the sensitivity curves.

There was not a significant increase though in the sensitivity level compared to the previous MiniCan-6, since neither the basic transduction nor the preamplifier was changed, and similar noise levels were achieved.

Attempting to understand the effect of the mechanical resonances of the metallic components using a resonance test device instead of more expensive and time consuming FEA methods taught us the important lesson that the lowest mechanical resonance of the assembled device is the lowest resonance of its biggest component. In this case, it is the aluminum base whose lowest resonance coincides with the one of the assembled MiniCan-7.

Similarly, the effect that the electronic cable has on the performance of a hydrophone proved to be small, though perhaps not negligible, over the frequency range of interest for MiniCan. This effect was further reduced by filling a portion of the cable near the transducer with a silicon RTV compound.

Though MiniCan can only be improved modestly, for example by making the pads supporting the PZT on lid and base slotted, the design proved to be a cheap, easy to build, small and reliable hydrophone, comparable in performance with bigger and more expensive commercial designs.

THIS PAGE INTENTIONALLY LEFT BLANK

LIST OF REFERENCES

1. Anan'eva Alevtina Aleksandrova, *Ceramic Acoustic Detectors*, translated from Russian, Consultants Bureau, New York, 1965.
2. Bobber J. Robert, *Underwater Electroacoustics Measurements*, Naval Research Laboratory Underwater Sound Reference Division, Orlando, Florida, 1970.
3. Bruel & Kjaer Sound and Vibration Measurement Inc., hydrophones brochure, Available [online] at: <http://www.bk.dk>, 21 May 2004.
4. Lawrence Kinsler E., Frey Austin R., Coppens Alan B., Sanders James V., *Fundamentals of Acoustics*, Fourth Edition, John Wiley & Sons, 2000.
5. Urick Robert J., *Principles of Underwater Sound*, Third Edition, Peninsula Publishing, Los Altos, California, 1996.
6. Wenz Gordon M., *Acoustic Ambient Noise in the Ocean: Spectra and Sources*, J. Acoust. Soc. Am. 34, 1962.
7. Wilson Oscar Bryan, *Introduction to Theory and Design of Sonar Transducers*, Peninsula Publishing, Los Altos, California, 1988.

THIS PAGE INTENTIONALLY LEFT BLANK

INITIAL DISTRIBUTION LIST

1. Defense Technical Information Center
Ft. Belvoir, Virginia
2. Dudley Knox Library
Naval Postgraduate School
Monterey, California
3. Professor Thomas Hofler, Code PH/Hf
Department of Physics, Naval Postgraduate School
Monterey, California
4. Professor Bruce Denardo, Code PH/De
Department of Physics, Naval Postgraduate School
Monterey, California
5. Chairman, Physics Department
Naval Postgraduate School
Monterey, California
6. Chair, Engineering Acoustics Academic Committee
Naval Postgraduate School
Monterey, California
7. Engineering & Technology Curricular Office (Code 34)
Naval Postgraduate School
Monterey, California
8. Degrees Processing Office
Chilean Navy Education Department
Valparaiso, Chile
9. Lt Mario Magliocchetti P.
Chilean Navy Programs and Development Office
Valparaiso, Chile