

**United States Joint Forces Command
Joint Warfighting Center**



*Regional Security
Cooperation through
Education and Training
Technology*



**United States Joint Forces Command
Joint Force Trainer**

Report Documentation Page

*Form Approved
OMB No. 0704-0188*

Public reporting burden for the collection of information is estimated to average 1 hour per response, including the time for reviewing instructions, searching existing data sources, gathering and maintaining the data needed, and completing and reviewing the collection of information. Send comments regarding this burden estimate or any other aspect of this collection of information, including suggestions for reducing this burden, to Washington Headquarters Services, Directorate for Information Operations and Reports, 1215 Jefferson Davis Highway, Suite 1204, Arlington VA 22202-4302. Respondents should be aware that notwithstanding any other provision of law, no person shall be subject to a penalty for failing to comply with a collection of information if it does not display a currently valid OMB control number.

1. REPORT DATE 00 NOV 2003	2. REPORT TYPE N/A	3. DATES COVERED -	
4. TITLE AND SUBTITLE Regional Security Cooperation through Education and Training Technology		5a. CONTRACT NUMBER	
		5b. GRANT NUMBER	
		5c. PROGRAM ELEMENT NUMBER	
6. AUTHOR(S)		5d. PROJECT NUMBER	
		5e. TASK NUMBER	
		5f. WORK UNIT NUMBER	
7. PERFORMING ORGANIZATION NAME(S) AND ADDRESS(ES) US Joint Forces Command Joint Warfighting Center 116 Lakeview Parkway Suffolk, VA 23435-2697 USA		8. PERFORMING ORGANIZATION REPORT NUMBER	
9. SPONSORING/MONITORING AGENCY NAME(S) AND ADDRESS(ES)		10. SPONSOR/MONITOR'S ACRONYM(S)	
		11. SPONSOR/MONITOR'S REPORT NUMBER(S)	
12. DISTRIBUTION/AVAILABILITY STATEMENT Approved for public release, distribution unlimited			
13. SUPPLEMENTARY NOTES See also ADM001655., The original document contains color images.			
14. ABSTRACT			
15. SUBJECT TERMS			
16. SECURITY CLASSIFICATION OF:			17. LIMITATION OF ABSTRACT
a. REPORT unclassified	b. ABSTRACT unclassified	c. THIS PAGE unclassified	UU
			18. NUMBER OF PAGES 28
			19a. NAME OF RESPONSIBLE PERSON



US DoD Objectives for Security Cooperation

Regional Security Cooperation through Education and Training Technology



- **Build the capabilities of allies, friends, and potential coalition partners to conduct coalition operations and defend themselves.**
- **Develop long-term military ties that will provide coalition capabilities for future contingencies.**
- **In Europe, sustain NATO as the preeminent European security institution by promoting transformation...and supporting initiatives to improve NATO members' capabilities.**



NATO/PfP Objectives and Priorities



Regional Security Cooperation through Education and Training Technology

- **Objectives of the Enhanced and More Operational PfP:**
 - Strengthen the political consultation element of PfP
 - Develop a more operational role for PfP
 - Provide for greater involvement of partners in PfP planning & decision-making
- **Priorities of the PfP Training and Education Enhancement Program (MCM 211-99):**
 - Language
 - Basic & specialized training & NATO terminology at operational & tactical levels
 - Training of staff officers & NCOs for a combined & joint environment
 - Understanding NATO military doctrine & standards
 - Command & control arrangements
 - Practice of staff procedures



NOTES FOR SLIDE 3



Regional Security Cooperation through Education and Training Technology

- **The US security cooperation strategy is focused on sustaining relationships with our allies and enhancing our mutual capabilities and operational effectiveness.**
- **NATO's PfP program provides the perfect venue for developing coalition interoperability and promoting security cooperation.**
- **The US is dedicated to working within the PfP framework to make the Training and Education Enhancement Program effective and meet the priorities set by the Military Committee.**



NMSG Related Tasks



Regional Security Cooperation through Education and Training Technology

- **MCM 211-99 Tasking**
 - Evaluate existing and developing techniques and opportunities for NATO and PfP on distributed learning and simulation.
- **MCM-049-02 Tasking**
 - Report on PfP CAX requirements for combined & joint HQ training
 - Report on feasibility of CAX capability for distributed PfP HQ training
 - Develop recommendations of what a PfP simulation network should be
 - Investigate what connections should link the various TEEP PfP and “in the spirit of PfP” initiatives



NOTES FOR SLIDE 5



Regional Security Cooperation through Education and Training Technology

- **NMSG has been heavily tasked by the Military Committee to evaluate how NATO and PfP can best benefit from the advances made in Information Technology, specifically Advanced Distributed Learning and Modeling and Simulation.**
- **USJFCOM supports the NATO study on ADL today by joining in courseware development and managing a knowledge portal for SACLANT.**
- **Similarly, USJFCOM supports NMSG in its study on modeling and simulation.**



Regional Security Cooperation Network

Regional Security Cooperation through Education and Training Technology



A Triad of Technology

- **Global coalition education & training**
- **A management improvement tool**
- **Cost-effective training**
- **Allied/Coalition interest**
- **Allied/Coalition facilities**
- **Proven performance**
- **Today's technology**

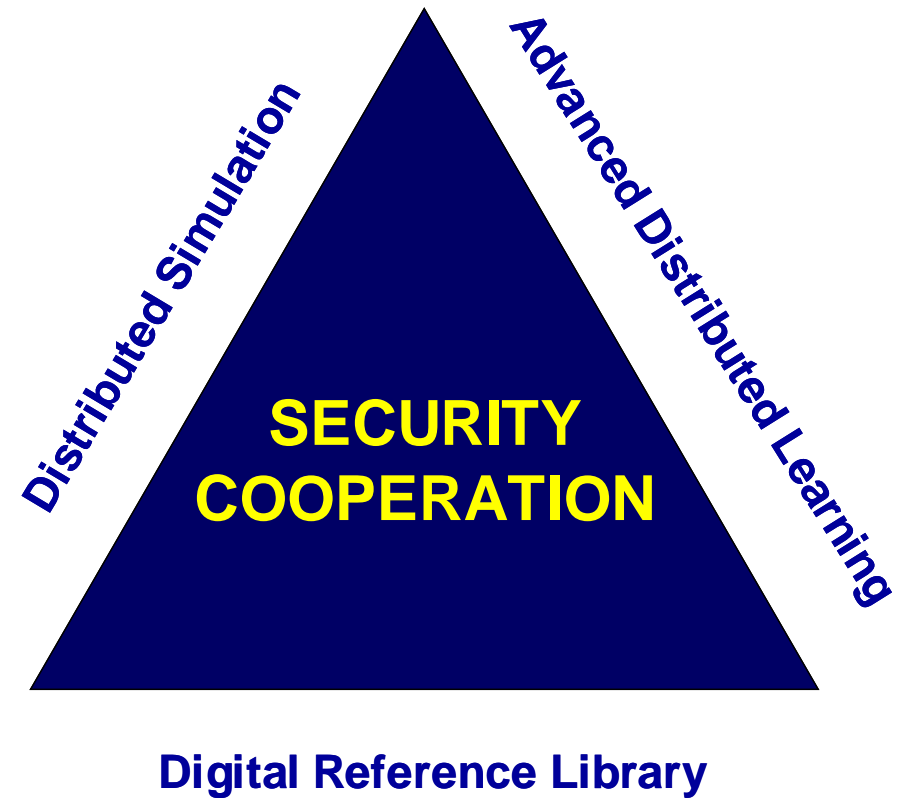



NOTES FOR SLIDE 7



Regional Security Cooperation through Education and Training Technology

- **The Regional Security Cooperation Network is a DoD initiative intended to enhance coalition education and training through the use of Information Technology.**
- **The individual elements of this concept have been employed successfully as individual efforts until recently. USJFCOM is working with other US combatant commanders to transform the way we train with our allies. Our goal is to integrate each element in a comprehensive coalition education and training program that will provide educational material and practical training to promote interoperability at the middle and senior staff levels.**



RSCN Link to Military Operations



Regional Security Cooperation through Education and Training Technology



Peace

Conflict

War

RSCN

Cooperation

- Coordination
- Communication
- Understanding

and

Interoperability

- Education and training
- Compatible resources
- Shared knowledge

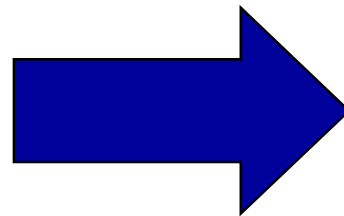

Stability

and

Security



NOTES FOR SLIDE 9



Regional Security Cooperation through Education and Training Technology

- **By developing cooperation and interoperability, we promote stability and security.**
- **To date, our efforts have targeted the low intensity conflicts of the spectrum of military operations. But, with experience and authority, this concept can easily be adapted to direct combat training.**



Transforming PfP Training



Regional Security Cooperation through Education and Training Technology

- **Field Training Exercises (FTX)** → *Command post exercises (CPX) and Computer-assisted exercises (CAX)*
- **Single site exercises** → *Multiple distributed site exercises*
- **Company/Platoon leaders focus** → *Brigade and CJTF staff focus*
- **Tactical unit training** → *Functional component training*
- **Generic scenarios** → *Adaptable, relevant scenarios*
- **Limited classroom training** → *Expanded education base through ADL*



NOTES FOR SLIDE 11



Regional Security Cooperation through Education and Training Technology

- **In keeping with our US goals and the NATO/PfP objectives, USJFCOM modifying its coalition training strategy to achieve a more effective return for the time and money invested in training.**
- **Innovative ideas in scenario development and exercise design will enable the US and its coalition partners to rapidly move forward in our common quest for interoperability.**
- **We want to train more people in a more realistic environment, challenge the decision-makers, test our procedures, find the weak points and eliminate our inefficiencies.**



Distributed Simulation-based Exercises



Regional Security Cooperation through Education and Training Technology

- **Viking exercises** – Peace Support Operations scenario

- US provided technical support
- Swede-led CAX; Multinational Brigade
- Viking 99: 6 sites/24 nations/550 participants
- Viking 01: 5 sites/17 nations/450 participants

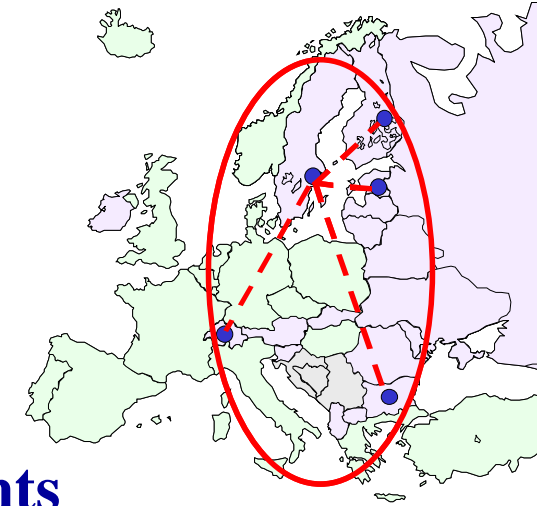

- **Cooperative Nugget 02** – SACLANT/USJFCOM sponsored

- Introduction to CJTF
- Combined Joint Force Land Component Commander
- Brigade level staffs
- 5 PfP GO/FO participated
- 3 sites/23 nations/440 participants

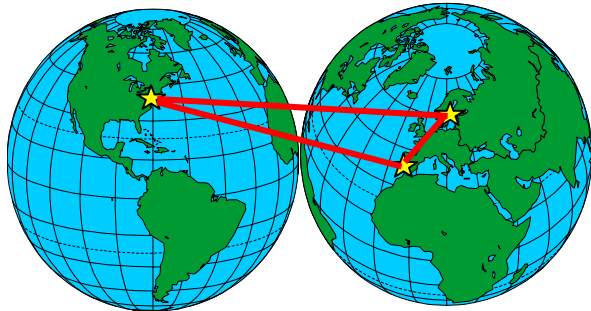



NOTES FOR SLIDE 13



Regional Security Cooperation through Education and Training Technology

- **The first two Viking exercises were successful single multinational brigade peace support operation computer assisted exercises. They represented the initial step in enhancing our coalition training through Information Technology.**
- **In Cooperative Nugget 02, we took a large step toward coalition interoperability by introducing the Land Component Commander element of the CJTF concept.**
- **However, we need to integrate the power of ADL and digital libraries in our future exercises.**



South Eastern Europe Simulation Network

Regional Security Cooperation through Education and Training Technology



- Supports NATO's Southeastern Europe Initiative
- Disaster relief scenario
- Foundation for integrating
 - SEEBRIG/ETF
 - CMEP
 - Communications
- Prelude to regional live exercises and real world operations
- Demo and exercise in 2002
- Greece hosts 02; Turkey hosts 04
- 9 sites/9 nations





NOTES FOR SLIDE 15



Regional Security Cooperation through Education and Training Technology

- **SEESIM 02 is a unique approach to enhancing civil-military cooperation at the national and international levels.**



Advanced Distributed Learning



Regional Security Cooperation through Education and Training Technology

- Internet Technologies
- Video Teleconferencing
- Multimedia Data Management

Technology

- Curriculum Development
- Courseware Development
- Accreditation and Reuse
- Configuration Management

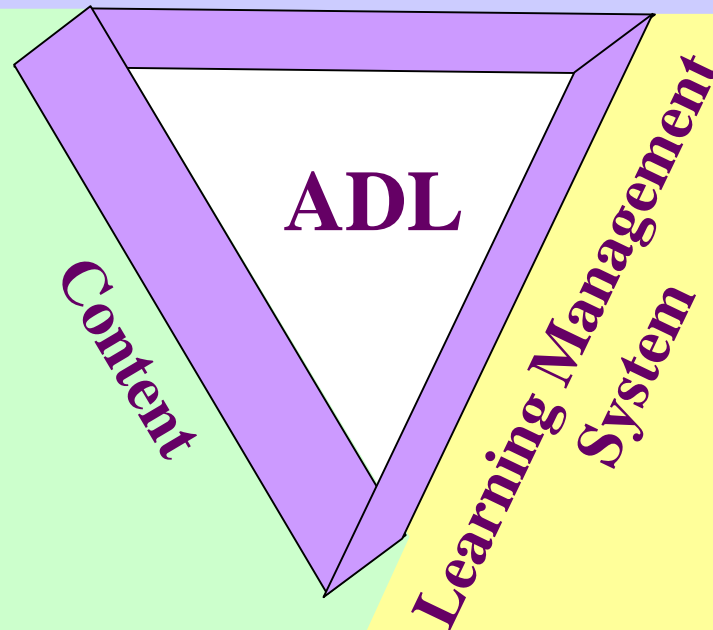

- Student services
- Scheduling
- Resource Management
- Testing
- Tracking
- Reporting
- Database Management



NOTES FOR SLIDE 17



Regional Security Cooperation through Education and Training Technology

- **This slide shows some of the many capabilities resident in a well-developed ADL program.**
- **Education via this medium can support the tactical, operational and strategic levels of military education.**
- **It is not envisioned as a replacement for resident education, but rather, an enhancement to the classroom experience.**
- **Similarly, a staff officer can receive specific educational content to better prepare him for his duties in an exercise or actual staff assignment.**



ADL – The Road Ahead



Regional Security Cooperation through Education and Training Technology

- **Satisfy the Military Committee’s TEEP priorities**
- **Collaborate with NATO School (SHAPE) to develop an ADL capability**
- **Explore the ADL needs of NATO Defence College**
- **Develop required educational material in collaboration with the NATO Defence College and NATO School (SHAPE)**
 - IAW MC’s priorities
 - Refine existing CJTF training modules
 - NATO review, collaborative development & certification
 - Pursue collaborative development of Peace Support Operations Staff Officer Course with Swedish International Training Center
- **Deliver ADL courseware to support education and training**
 - Convert course material to ADL standards (SCORM)
 - In the classroom and in preparation for exercises or operations
- **Integrate ADL capabilities with CPX/CAX event.**



NOTES FOR SLIDE 19



Regional Security Cooperation through Education and Training Technology

- **USJFCOM intends to work closely with NATO/PfP to achieve these goals in the near future.**



Viking 03 – An Integrating Event



Regional Security Cooperation through Education and Training Technology

- **Multiple Multinational Brigade (MNB) structure**
 - Train committed or rapid reaction forces
- **Integrate ADL preparation**
 - CAX Course
 - CJTF Course
- **NATO response cell for reporting procedures**
 - MNB must report to some higher HQ
 - Simple addition to exercise
 - Adds reality to MNB procedures

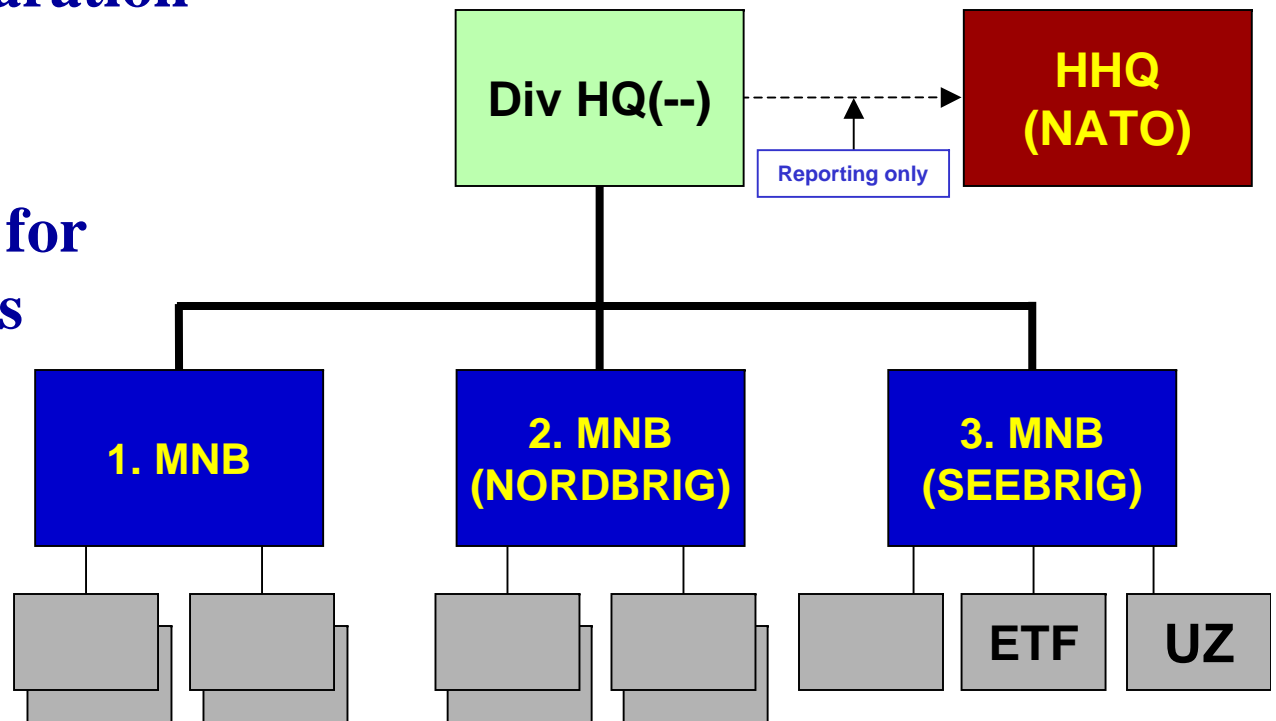

Satisfies NATO/PfP/TEEP interoperability goals



NOTES FOR SLIDE 21



Regional Security Cooperation through Education and Training Technology

- **Working closely with our Swedish counterparts, we have significantly raised the level of interoperability training for Viking 03.**
- **You can see that we now have 3 multinational brigades coordinating activities within the scenario, our training audience spans from northern Europe, to southeastern Europe, and to Central Asia, and we have introduced a NATO reporting link.**
- **Additionally, we plan to introduce ADL training to prepare the participants for the exercise.**



Toward a More Operational PfP



Regional Security Cooperation through Education and Training Technology

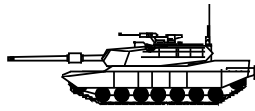
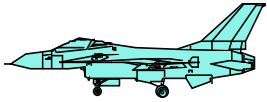

Distributed
CAX

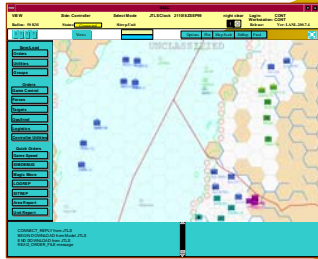

- ✓ Peace Support Operations
- ✓ Humanitarian Assistance
- ✓ Disaster Relief

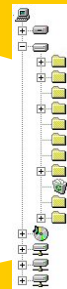

Digital Libraries



ADL

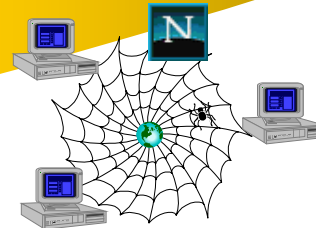

Internet Technology



Courseware



NOTES FOR SLIDE 23



Regional Security Cooperation through Education and Training Technology

- **By integrating the elements of ADL, digital reference libraries, and distributed CAXs, we will make greater advances toward interoperability.**



Summary



Regional Security Cooperation through Education and Training Technology

- **Regional Security Cooperation leverages technology to achieve the goals of EMOP and TEEP:**
 - **Implementing and advancing the use of distributed, simulation based exercises.**
 - **Trains staff officers and NCOs in a combined and joint operational environment.**
 - **Furthers Partner understanding and execution of NATO doctrine and procedures.**
 - **Exercises command and control elements.**
 - **Enables staff procedural training.**
 - **Implements Advanced Distributed Learning tools and technologies.**
 - **Provides greater throughput for language training.**
 - **Enhances staff officer and NCO training.**
 - **Improves knowledge and understanding of NATO doctrine.**
 - **Leads to enhanced interoperability among NATO and Partner military forces.**

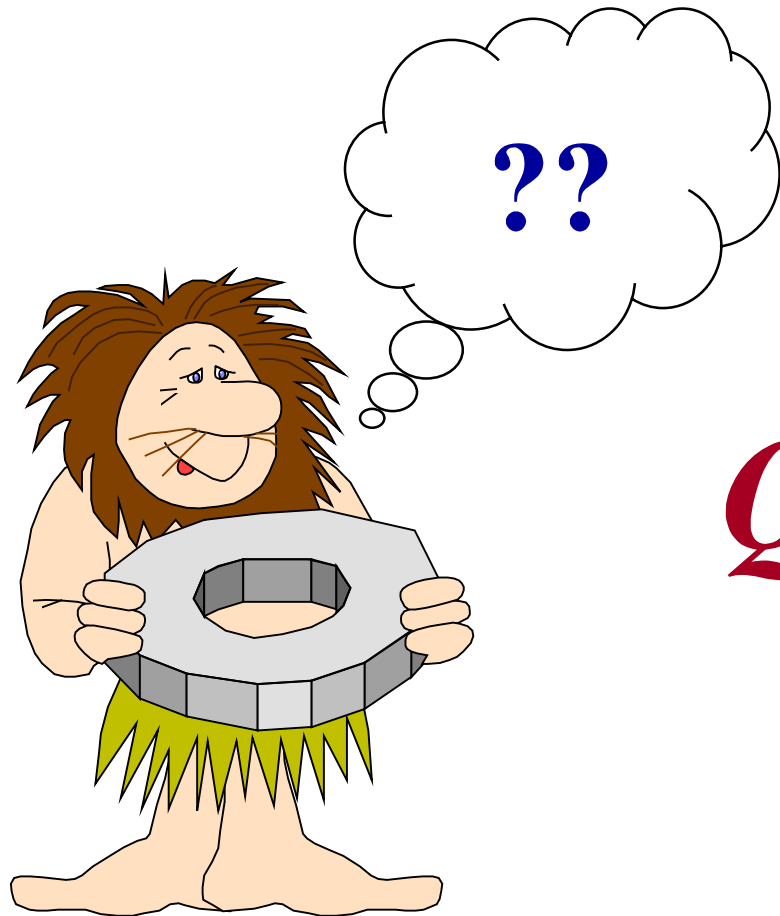

Questions?

This page has been deliberately left blank

Page intentionnellement blanche

Regional Security Cooperation through Education and Training Technology

Mr James Bolcar

US Joint Forces Command
Joint Warfighting Center
116 Lakeview Parkway
Suffolk, VA 23435-2697
USA

Mr Walter Christman

Chemin de la Rupille 7
CH-1273, Arzier, VD
SWITZERLAND

*This paper was received as a PowerPoint
presentation without supporting text.*

This page has been deliberately left blank

Page intentionnellement blanche