



**NAVAL  
POSTGRADUATE  
SCHOOL**

**MONTEREY, CALIFORNIA**

**THESIS**

**A SELECTIVE AUTOMATIC REPEAT REQUEST  
PROTOCOL FOR UNDERSEA ACOUSTIC LINKS**

by

Jon M. Kalscheuer

June 2004

Thesis Advisor:

Co-Advisor:

Joseph A. Rice

Thomas J. Hofler

**Approved for public release; distribution is unlimited**

THIS PAGE INTENTIONALLY LEFT BLANK

REPORT DOCUMENTATION PAGE			Form Approved OMB No. 0704-0188
Public reporting burden for this collection of information is estimated to average 1 hour per response, including the time for reviewing instruction, searching existing data sources, gathering and maintaining the data needed, and completing and reviewing the collection of information. Send comments regarding this burden estimate or any other aspect of this collection of information, including suggestions for reducing this burden, to Washington headquarters Services, Directorate for Information Operations and Reports, 1215 Jefferson Davis Highway, Suite 1204, Arlington, VA 22202-4302, and to the Office of Management and Budget, Paperwork Reduction Project (0704-0188) Washington DC 20503.			
1. AGENCY USE ONLY (Leave blank)	2. REPORT DATE June 2004	3. REPORT TYPE AND DATES COVERED Master's Thesis	
4. TITLE AND SUBTITLE: Title (Mix case letters) A Selective Automatic Repeat Request Protocol for Undersea Acoustic Links			5. FUNDING NUMBERS
6. AUTHOR(S) Jon M. Kalscheuer, ENS USNR			
7. PERFORMING ORGANIZATION NAME(S) AND ADDRESS(ES) Naval Postgraduate School Monterey, CA 93943-5000			8. PERFORMING ORGANIZATION REPORT NUMBER
9. SPONSORING /MONITORING AGENCY NAME(S) AND ADDRESS(ES) N/A			10. SPONSORING/MONITORING AGENCY REPORT NUMBER
11. SUPPLEMENTARY NOTES The views expressed in this thesis are those of the author and do not reflect the official policy or position of the Department of Defense or the U.S. Government.			
12a. DISTRIBUTION / AVAILABILITY STATEMENT Approved for public release; distribution is unlimited			12b. DISTRIBUTION CODE A.
13. ABSTRACT (maximum 200 words) A recent improvement to the Seaweb underwater wireless network was the implementation of a Selective Automatic Repeat Request (SRQ) mechanism. SRQ is a protocol implemented in the Seaweb link layer as a measure for mitigating unreliability inherent in the telesonar physical layer. In January 2004, an experiment was performed in St. Andrew's Bay, Panama City, Florida. The goal was to transmit large data files through the network, in accordance with a Naval Special Warfare need for imagery file telemetry. For three point-to-point test geometries, SRQ was tested with a noisy and variable physical layer. Through the incorporation of SRQ, the unreliability was overcome. A link-budget model calibrated with the sound channel data collected from the experiment establishes the benefit of a "SRQ gain."			
14. SUBJECT TERMS SRQ, link-budget, acoustic communications, FORCEnet, link layer, telemetry, ARQ, telesonar, Seaweb			15. NUMBER OF PAGES 60
			16. PRICE CODE
17. SECURITY CLASSIFICATION OF REPORT Unclassified	18. SECURITY CLASSIFICATION OF THIS PAGE Unclassified	19. SECURITY CLASSIFICATION OF ABSTRACT Unclassified	20. LIMITATION OF ABSTRACT UL

THIS PAGE INTENTIONALLY LEFT BLANK

**Approved for public release; distribution is unlimited**

**A SELECTIVE AUTOMATIC REPEAT REQUEST PROTOCOL FOR  
UNDERSEA ACOUSTIC LINKS**

Jon M. Kalscheuer  
Ensign, United States Navy  
B.S. United States Naval Academy, 2003

Submitted in partial fulfillment of the  
requirements for the degree of

**MASTER OF SCIENCE IN APPLIED PHYSICS**

from the

**NAVAL POSTGRADUATE SCHOOL  
June 2004**

Author: Jon M. Kalscheuer

Approved by: Joseph A. Rice  
Thesis Advisor

Thomas J. Hofler  
Co-Advisor

James H. Luscombe  
Chairman, Department of Physics

THIS PAGE INTENTIONALLY LEFT BLANK

## **ABSTRACT**

A recent improvement to the Seaweb underwater wireless network was the implementation of a Selective Automatic Repeat Request (SRQ) mechanism. SRQ is a protocol implemented in the Seaweb link layer as a measure for mitigating unreliability inherent in the tele-sonar physical layer. In January 2004, an experiment was performed in St. Andrew's Bay, Panama City, Florida. The goal was to transmit large data files through the network, in accordance with a Naval Special Warfare need for imagery file telemetry. For three point-to-point test geometries, SRQ was tested with a noisy and variable physical layer. Through the incorporation of SRQ, the unreliability was overcome. A link-budget model calibrated with the sound channel data collected from the experiment establishes the benefit of a "SRQ gain."

THIS PAGE INTENTIONALLY LEFT BLANK

# TABLE OF CONTENTS

I.	INTRODUCTION.....	1
A.	SEAWEB UNDERWATER WIRELESS NETWORK.....	1
B.	TELESONAR TECHNOLOGY FOR NAVAL SPECIAL WARFARE....	1
II.	DIGITAL COMMUNICATIONS .....	3
A.	ISO/OSI STACKED MODEL .....	3
B.	ERROR CONTROL.....	4
C.	ARQ AS A FORM OF ERROR DETECTION .....	5
D.	SELECTIVE AUTOMATIC REPEAT REQUEST .....	5
E.	SEAWEB LINK LAYER .....	6
1.	RTS/CTS Handshaking.....	6
2.	Data Message Header (HDR).....	7
3.	Imagery File Telemetry .....	7
4.	SRQ Mechanism.....	7
III.	SEAWEB NSW 2004 EXPERIMENT (PANAMA CITY, FL).....	9
A.	EXPERIMENT PLAN.....	9
B.	EXPERIMENT SETUP.....	9
1.	St. Andrew’s Bay.....	9
2.	Network Setup.....	10
3.	SRQ Evaluation Setup.....	10
C.	SOUND PROPAGATION IN ST. ANDREWS’ BAY.....	11
D.	ST. ANDREW’S BAY ACOUSTIC NOISE.....	14
1.	Sources of Acoustic Noise.....	14
a.	Wind.....	14
b.	Boating .....	15
c.	Construction.....	15
d.	Biologics .....	15
2.	Noise Variability.....	15
IV.	ST. ANDREW’S BAY MODEM PERFORMANCE AND DATA COLLECTION .....	17
A.	TEST PROCEDURE .....	17
1.	Test Geometries.....	17
2.	Seaweb Database.....	17
3.	Transmit Power Level Setting .....	18
4.	Procedure.....	18
B.	OBSERVATIONS.....	19
V.	DATA ANALYSIS.....	23
A.	RECORDING STATION.....	23
1.	Transducer.....	23
2.	Preamplifier.....	23

3.	Tape Recorder .....	23
B.	DATA EXTRACTION .....	24
VI.	SELECTIVE ARQ RESULTS .....	27
A.	SNR BASED PERFORMANCE.....	27
B.	SRQ GAIN.....	29
VII.	INCORPORATING SRQ GAIN INTO LINK-BUDGET MODEL .....	31
A.	LINK BUDGET CALIBRATION.....	31
1.	Pressure Spectrum Level.....	31
2.	Ambient Noise .....	31
3.	Transmission Loss.....	32
B.	MODELING ST. ANDREW’S BAY.....	33
VIII.	FUTURE IMPROVEMENTS.....	37
A.	ABORT/CONTINUE LOGIC .....	37
B.	TIMEOUT LOGIC.....	37
C.	CROSS-LAYER TIME-DIVERSITY PROCESSING.....	37
IX.	CONCLUSIONS .....	39
	LIST OF REFERENCES .....	41
	INITIAL DISTRIBUTION LIST .....	43

## LIST OF FIGURES

Figure 1.	The seven layers of the OSI stacked model. SRQ is incorporated in the link Layer. Seaweb underwater network is responsible for network-, link-, and physical-layer protocols, while the remaining four are the specific application’s responsibility [2]. .....	4
Figure 2.	Representation of a typical dialogue between two nodes. Note that display on left can be condensed simply into bar graph on right, with each bar representing a single data transmission. The total height of the bar is the number of subpackets sent; green represents those successful, and red represents those corrupt. ....	7
Figure 3.	St. Andrew’s Bay with Seaweb network overlay. Links used specifically for SRQ evaluation are noted in yellow. Values shown represent distances in meters from specific node (R4, R5, or R8) to G1, the gateway buoy (after [6])......	11
Figure 4.	CTD measurement of St. Andrew’s Bay at location R4. Results are indicative of Bay in general. SIGMA-T represents water Density. Negative values for depth represent distance below surface. ....	12
Figure 5.	Sound speed profile at R4, indicative of Bay in general. Note gradient between one and three meters, refracting sound waves upward towards surface. ....	13
Figure 6.	Ray traces modeled from sound speed profile (Figure 5). Source is located in middle of water column at a depth of 3 meters. Note number of surface reflections that occur in first kilometer of propagation, and their effect on signal intensity, in color (colorbar values in decibels). While this is only a model based on the sound speed profile, it represents the difficulty of operating in a shallow-water environment. ....	14
Figure 7.	Experimental setup for SRQ Analysis. V3 transmits from its over-the-side dunking transducer and the G1 acoustic modem receives the signal. V3 and G1 remain in contact via FreeWave radio for immediate transmission confirmation. The dialogue underlay consists of one SRQ retry, with up to five possible. ....	19
Figure 8.	Transmission results for all three test geometries. A dialogue is represented as a group of bars, with power level noted below each. As explained in Figure 2, one bar represents a single transmission. The total height of the bar represents the total subpackets sent in that transmission; the height of the red portion of a bar represents those subpackets that were received corrupt. If the last bar (transmission) of a dialogue is fully green, the file was successfully sent. ....	21
Figure 9.	Sensitivity of ITC-1032 transducer. Over 9-14 kHz bandwidth the response curve is flat to within several dB. ....	24
Figure 10.	Stanford Analyzer display for transmissions at three different ranges. Note variability in noise levels and the range dependence of transmission	

	loss. Vertical lines at 9 and 14 kHz encompass modem signal transmission bandwidth. ....	25
Figure 11.	For all data at all three ranges, each independent transmission is displayed in order of decreasing SNR. Note that the plot is not linear with respect to SNR. ....	27
Figure 12.	Reception success rate plotted against received SNR for each transmission. Data points are weighted according to number of subpackets sent. The red line is a linear regression of all 80 data points. ....	28
Figure 13.	Link-budget model output for St. Andrew's Bay environment, without SRQ Gain. Power level setting is 8. Horizontal dashed lines indicate frequency bandwidth of interest. Green indicates successful reception areas, while yellow indicates the point at which the link begins to break down, and finally red indicates areas of no reception success. For this Figure, with no SRQ in place, the operating range is only around 1300 meters. ....	34
Figure 14.	Link-budget model output with SRQ gain incorporated. All other factors are same as Figure 12. Note new effective range out to more than 2000 meters. ....	35

## LIST OF TABLES

Table 1.	Experiment details for each of the three locations used in the SRQ evaluation.....	17
Table 2.	Seaweb Power Level relationship to acoustic Source Level. ....	18

THIS PAGE INTENTIONALLY LEFT BLANK

## ACKNOWLEDGMENTS

Considering my time here was limited, much help was needed in order to complete my thesis on time. I wish to thank the following people for their support:

To my thesis advisor, Joe Rice, who not only helped me pick a thesis topic, but also made sure I followed through with it. He encouraged me to travel to Panama City to take part in the Seaweb NSW 2004 Experiment, and provided every possible resource, including equipment, funding, documents, and expert personnel. Considering his travel schedule, he was always willing to make time to help me, and I am extremely fortunate to have worked with him.

To my co-advisor, Professor Tom Hofler, whose meticulous laboratory skills and unending insight insured a quality and worthwhile analysis. His experimental tips and operational know-how were an invaluable asset to my research.

To the staff at SPAWAR Systems Center in San Diego: Chris Fletcher and Bob Creber for their help with the Seaweb database, and Paul Baxley for his CTDs and ray traces.

To Mike Coryer from Benthos for helping me understand the SRQ as implemented in the acoustic modem.

Finally to the instructors and staff of the Physics Department, who allowed me to pursue acoustics as I desired, especially my academic advisors Professor Jim Sanders and Professor Daphne Kapolka, who helped me work all the requirements for a degree into one year.

THIS PAGE INTENTIONALLY LEFT BLANK

## I. INTRODUCTION

Selective Automatic Repeat Request (SRQ) is a link-layer mechanism used to mitigate the loss of data in a variable and unreliable physical layer. The SRQ protocol tested and evaluated in this report was that implemented in the U. S. Navy Seaweb underwater wireless network. The goal was successful telemetry of large imagery files for Naval Special Warfare (NSW) missions. The following is a brief description of Seaweb and its application to NSW.

### A. SEAWEB UNDERWATER WIRELESS NETWORK

Seaweb networks interconnect distributed undersea nodes. By use of acoustic signaling and digital communications theory, data packets can be sent through the underwater environment. The network incorporates the use of battery-operated modems that can be deployed as wide-area wireless grids for unattended operations in littoral environments. The Seaweb network can provide numerous services including communications, acoustic ranging, localization, and also imagery file telemetry. It also allows for collaboration with mobile nodes which can include submarines and autonomous undersea vehicles. Seaweb networking includes various communication gateways serving as interfaces between the distributed undersea nodes and manned command centers ashore, afloat, submerged, aloft, and afar [1].

### B. TELESONAR TECHNOLOGY FOR NAVAL SPECIAL WARFARE

With the emergence of Seaweb networking, a recent goal has been to apply this technology to Naval Special Warfare missions. Seaweb brings several new capabilities to the NSW mission including command and control, near-real time reporting, and imagery file telemetry. One important factor has been transmission security in order to reduce detectability by unauthorized listeners.

Raw images can be compressed into more manageable files (of about 1500 bytes) which can be sent through the Seaweb network. Problems in initial tests were caused by limitations of the underwater acoustic channel. With data rates of around 800 bits per second to 1200 bits per second, the transmission of a 1500-byte file is exposed to the variable underwater channel for a significant time. In initial tests, transmission of the 1500-byte file as a contiguous packet had a high failure rate. A proposed solution was

the implementation of a SRQ Protocol. With this mechanism in place, the files are divided into smaller subpackets, and retransmission of lost data is completed on a smaller scale, which eventually leads to successful transmission of the whole packet (compressed image).

## II. DIGITAL COMMUNICATIONS

SRQ is a link-layer mechanism. In order to understand this terminology, a discussion of the Open Systems Interconnection model follows, along with an introduction to error control for digital signals.

### A. ISO/OSI STACKED MODEL

The International Standards Organization's Open Systems Interconnection model is a reference model designed to allow for efficient communications between systems. A communications task across a network is split into manageable, cohesive subtasks to allow for efficient control [2]. The OSI model is a seven-layer model shown in Figure 1. As a file is sent from one system to another, it first travels down each layer of the model, with each layer applying a header with specific protocols. When the file reaches the lowest layer, the physical layer, the file is then transmitted through the medium, be it cable, air, or water. When the file reaches the other system it is then passed up through all the layers, with each layer stripping off its header and performing its appropriate function. The Seaweb network deals with the first three layers: physical, link, and network.

The physical layer, the lowest layer on the OSI model, is responsible for transmission of the actual stream of data through the propagation medium. This involves mapping a bit-stream into a signal appropriate for transmission given the electrical, mechanical, functional, and procedural characteristics of the medium. On the receiving end, the physical layer interprets the signal and performs the inverse mapping. The modulating and demodulating of the signal is usually done by a modem. The bit stream is then sent up to the next layer, the link layer.

The link layer provides the higher layers a reliable point-to-point packet pipe over a single link. The link layer organizes the data into packets and subpackets, and attaches headers and trailers along with other overhead control bits. In the case of Seaweb, a 9-byte header carrying information such as node addresses is attached to all transmissions. Also included in the link layer are protocols which deal with the issues of handshaking and medium access control.

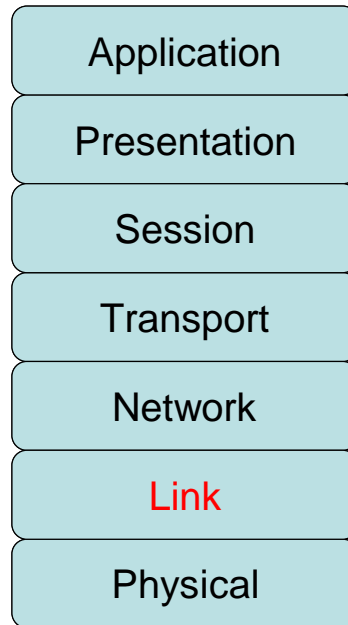

Figure 1. The seven layers of the OSI stacked model. SRQ is incorporated in the link Layer. Seaweb underwater network is responsible for network-, link-, and physical-layer protocols, while the remaining four are the specific application's responsibility [2].

The network layer resides directly above the link layer and, as the name suggests, deals with communications between systems within a network. It is present at every network node, and its main purpose is to hide from its upper layers the underlying network technology and topology. The goal of the network layer is to efficiently deliver packets from one destination in the network to another. In order to achieve this, routing and flow control must be implemented.

## **B. ERROR CONTROL**

Detecting and correcting errors in packets transmitted between two nodes in a network is the responsibility of the link layer. The protocols implemented with this objective fall under the concept of error control. Error control deals with the detection and, in some cases, correction of errors that occur during the transmission of subpackets (resulting in lost or damaged subpackets). In order to detect such errors, extra bits must be added to the subpackets. The number of added bits depends on what kind of error control is being implemented. In the case of forward error correction (FEC), redundant

bits are encoded into the subpacket in order to reconstruct, or decode, the signal if corrupted. In order for FEC to be successful in the presence of bit-errors, a substantial amount of redundancy must be added to the data.

### **C. ARQ AS A FORM OF ERROR DETECTION**

In addition to forward error correction (FEC), automatic repeat request (ARQ) is a mechanism that detects and handles errors that are uncorrectable by FEC. The ARQ protocol detects the presence of uncorrected bits, and if a packet is determined to be corrupt, the receiver asks for it to be re-transmitted. To detect corruption, a series of check-bytes are added to the packet. The simplest of these is a checksum which treats the message as if it was a sequence of bytes and sums them [3]. The most common checksum is called a Cyclic Redundancy Check (CRC) code, which uses binary long division. In a CRC code, redundancy bits are added based on the contents of the packet. When the signal is received, the CRC performs its function and determines if the signal has been corrupted. The ARQ protocol automatically requests that the corrupted signal be resent. A 16-bit CRC code has the capacity to detect 99.9985% of all errors possible in a packet [4].

### **D. SELECTIVE AUTOMATIC REPEAT REQUEST**

In the case of Selective ARQ (SRQ), the entire packet is divided into smaller subpackets of equal size, each with its own CRC code. When a packet is received, errors are checked for on a subpacket level. The “selective” feature picks out the corrupted subpackets and has only those retransmitted, instead of the entire packet, which can be time-intensive. This is done repeatedly until every subpacket has been received uncorrupted, or until the process times out.

The acoustic modem currently used by Seaweb is manufactured by Benthos, Inc. This modem is programmed with SRQ as a link layer mechanism in order to recover messages that contain errors. The following is a description of SRQ as it is presently implemented.

The Seaweb link layer attaches a 9-byte header to all data packets sent. The maximum size of a packet is 2048 bytes. This packet can be broken down into 8 subpackets, each of 256 bytes. Included in each subpacket is the aforementioned 16-bit CRC code [5].

When a data packet is received, the CRC is calculated for each subpacket and then compared to the transmitted CRC code. A CRC status variable is constructed as an 8-bit mask with 1 bit for each of up to 8 subpackets. If the CRC check passes for a given subpacket, then the status variable is unchanged. If a CRC check fails, which means a subpacket contained an uncorrectable bit error, a one is written into the status variable at that subpacket's specific location in the mask.

The received data packet and the CRC status variable are sent to the SRQ protocol manager. The protocol manager copies the received data packet into a temporary buffer and checks the CRC bit-field for any value other than zero. If a value other than zero exists, an SRQ message is sent back to the transmitting modem with the CRC status variable. The originating modem then retransmits only those subpackets masked by the CRC status variable. The receiving modem then receives the same number of subpackets back as requested. It again performs the CRC check on the data and copies the good subpackets into the buffer. Another CRC status variable is constructed, and if there are any ones, another SRQ with a CRC mask is sent back to the originating modem, again asking for retransmission of only those subpackets that were corrupted. This continues until either the data message is received in full, or the maximum number of SRQ retries is exceeded. The maximum number of retries is not set in the hardware, but can vary due to the needs of the network.

## **E. SEAWEB LINK LAYER**

The Seaweb underwater network contains several link-layer protocols for managing successful transmissions. These are generally implemented in the form of efficient 9-byte utility packets.

### **1. RTS/CTS Handshaking**

In normal operations, two acoustic modems (nodes in the Seaweb network) first perform a handshake to establish a link. This is done with a series of short transmissions. The node transmitting data (node A) sends a 9-byte Request to Send (RTS) utility packet which serves to wake up the receiving node and prepare it for an incoming message. The receiving node (node B) acknowledges node A by sending back a 9-byte Clear to Send (CTS) utility packet. This process is what is called RTS/CTS handshaking and it

supports addressing, ranging, channel estimation, power control, and adaptive modulation [1].

## 2. Data Message Header (HDR)

When a node sends a data message it attaches a 9-byte header (HDR) utility packet which includes information similar to the RTS/CTS. The HDR is also used to insure the correct signal is being received, since there may be other traffic on the network. The HDR also makes it possible to communicate without benefit of RTS/CTS handshaking.

## 3. Imagery File Telemetry

In testing the transmission of images through the Seaweb network, the file size was 1532 bytes with 6 256 byte subpackets. Figure 2 outlines a typical dialogue between nodes for the transmission of such an image. The bar-graph representation is useful in representing whole data sets.

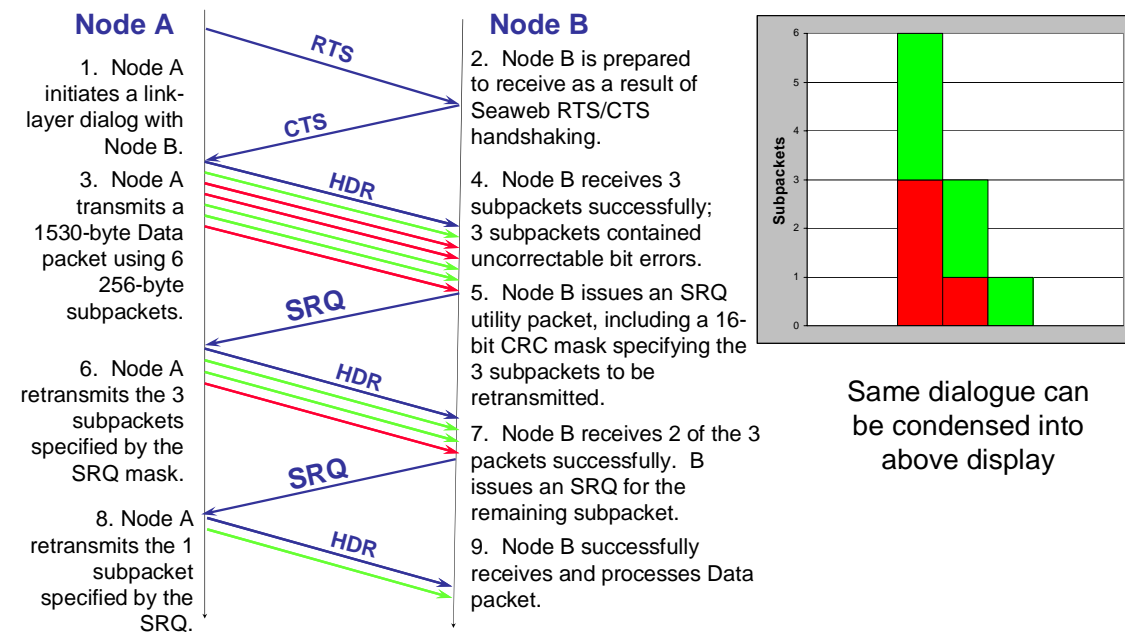

Figure 2. Representation of a typical dialogue between two nodes. Note that display on left can be condensed simply into bar graph on right, with each bar representing a single data transmission. The total height of the bar is the number of subpackets sent; green represents those successful, and red represents those corrupt.

## 4. SRQ Mechanism

The SRQ mechanism is invoked if the received data packet is corrupt. The 9-byte SRQ transmission is yet another utility packet format.

THIS PAGE INTENTIONALLY LEFT BLANK

### **III. SEAWEB NSW 2004 EXPERIMENT (PANAMA CITY, FL)**

#### **A. EXPERIMENT PLAN**

In January 2004, an experiment was held in St. Andrew's Bay, FL. With the combined efforts of Coastal Systems Station, Panama City, FL, SPAWAR Systems Center, San Diego, CA, and the Naval Postgraduate School, Monterey, CA, the experiment sought to test Seaweb's applicability to several Naval Special Warfare missions. A Seaweb network was deployed using Benthos commercial modem hardware. The Seaweb network included two radio/acoustic communications (RACOM) gateway buoys, with Iridium and FreeWave<sup>1</sup> radios. Along with their radio communications, the RACOMs each have a teleonar modem that is part of the underwater network. The use of a Seal Delivery Vehicle (SDV) periscope controller as a Seaweb graphical user interface proved successful. In addition, the link margin was tested throughout the network to both evaluate the performance of the SRQ protocol and obtain data in support of transmission security studies [6]. The experiment was tailored to NSW specific applications, stressing the effectiveness of transmitting large data files through the network. Factors affecting the efficiency of the network were examined in order to optimize its performance, in accordance with NSW's need for near-real-time reporting. One of these factors was the effectiveness of the SRQ protocol, especially with transmission of large imagery files. The files used were compressed intelligence/surveillance/reconnaissance (ISR) and mine-countermeasure (MCM) images of approximately 1500 bytes [6].

#### **B. EXPERIMENT SETUP**

##### **1. St. Andrew's Bay**

The experiment site was located in St. Andrew's Bay, Panama City, Florida, on the Gulf of Mexico coast. The Bay is part of the inter-coastal waterway system, which can often be busy with commercial traffic and private vessels. The bathymetry is displayed in Figure 3. Shallow-water propagation characteristics apply, with an average depth of 5-10 meters. The bottom consists of an acoustically absorptive mud/silt

---

<sup>1</sup> FreeWave Technologies, Inc., Boulder, CO.

composition. Currents are tidally influenced. The experiment was conducted in January, during the coolest season.

## **2. Network Setup**

Figure 3 also shows the location of the nodes composing the Seaweb network. The circles denote the nodes, and the lines represent network propagation paths. Two gateway nodes, G1 and G2, were used along with five repeater nodes, R4 through R8. The gateway nodes consisted of a floating buoy equipped with radio communications gear and telesonar modem. Each repeater node consisted of a telesonar modem tethered to the seafloor with a floating buoy to allow for recovery. Future implementation of the Seaweb network will include disposable repeater nodes. The SDV periscope controller was kept on a surface vessel for convenience and mobility, and was connected to the Seaweb network via an over-the-side dunking transducer. Its Seaweb nodal identification was V3. Multi-link image transmissions were performed through the network in the January experiment. Testing numerous network routes, the transmissions attained a high success rate, due in part to the implementation of SRQ, as will be shown.

## **3. SRQ Evaluation Setup**

Figure 3 also overlays the links, in yellow, used to test the performance of the SRQ protocol being evaluated in-water for the first time. The three links were from R4, R5, and R8 each to G1, the gateway node with a FreeWave radio antenna. These three test geometries while differing in range also covered different cross-sections of the Bay, in order to generalize the results. For the SRQ portion of the experiment, each of the three links were actually established with the V3 mobile node positioned at the R4, R5, and R8 locations instead of with the repeater node itself. There were several advantages to this. It was important that the same two transducers were used in all three test geometries (V3 to G1) so as to limit any possible hardware variation. From the interface, an operator could quickly set the transmit power level. With the mobile node positioned at the specific location, the dunking transducer was placed over the side at the appropriate depth. The mobile node V3 was a research vessel equipped with radio communications and a computer interface which allowed for network administration. When a sonar signal was sent from V3 to G1, immediate feedback arrived from G1 to V3 over FreeWave

radio. This setup allowed for immediate knowledge of signal success which led to modification of transmit power level in order to reduce the link margin to failure.

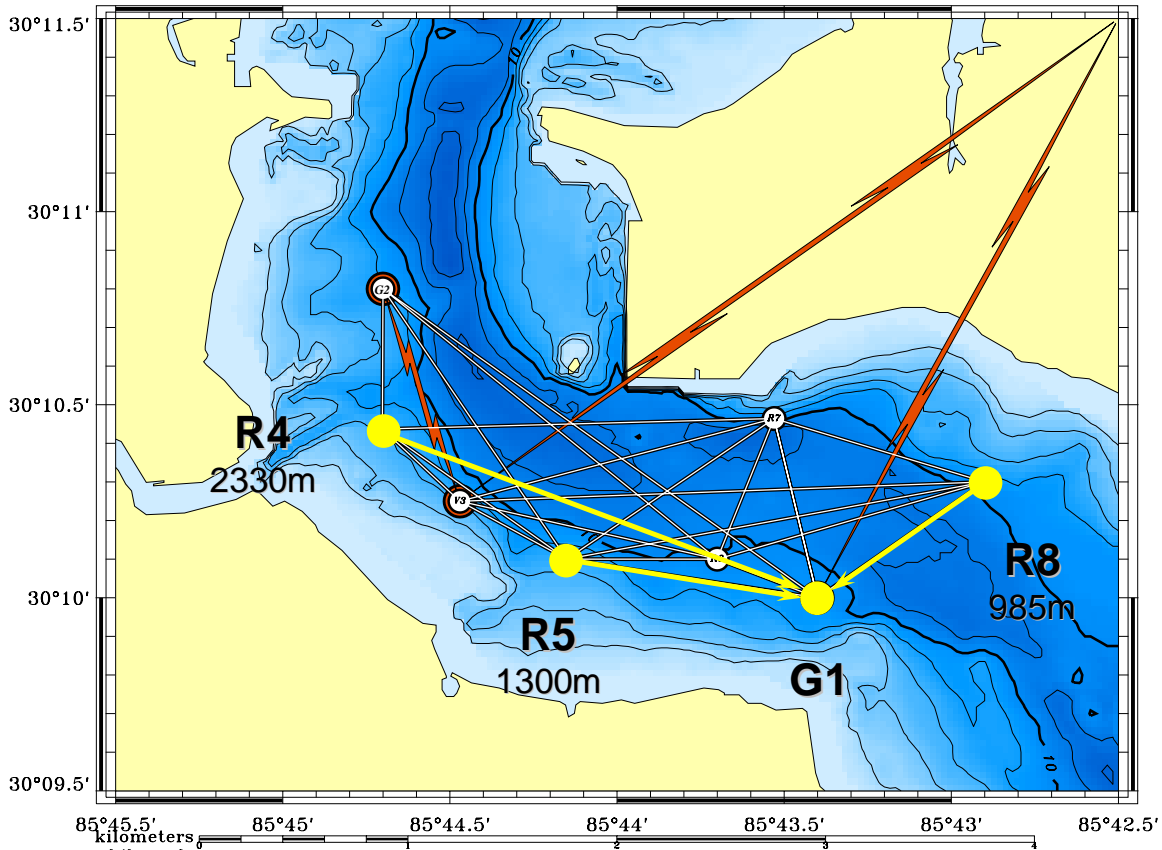

Figure 3. St. Andrew's Bay with Seaweb network overlay. Links used specifically for SRQ evaluation are noted in yellow. Values shown represent distances in meters from specific node (R4, R5, or R8) to G1, the gateway buoy (after [6]).

### C. SOUND PROPAGATION IN ST. ANDREWS' BAY

As mentioned, one of the objectives was to monitor the acoustic propagation characteristics throughout the experiment. Characteristics of the water column were taken at various times and locations, including temperature, salinity, and density. Figure 4 displays CTD (Salinity, Temperature, Density measurement device) data for the water column at location R4. The depth at this location was six meters and the results are indicative of the Bay in general. Nearby freshwater sources contribute to the layer of brackish, cool water on top of a layer of saltier, warmer water from the Gulf of Mexico. Below three meters the column is well mixed. This layering results in an upward-refracting sound speed profile, shown in Figure 5. Sound waves propagating down the

channel are forced to reflect off the surface repeatedly. This is undesirable because the propagation becomes dependent on surface roughness, just one of many difficulties inherent in propagation in a shallow-water littoral environment.

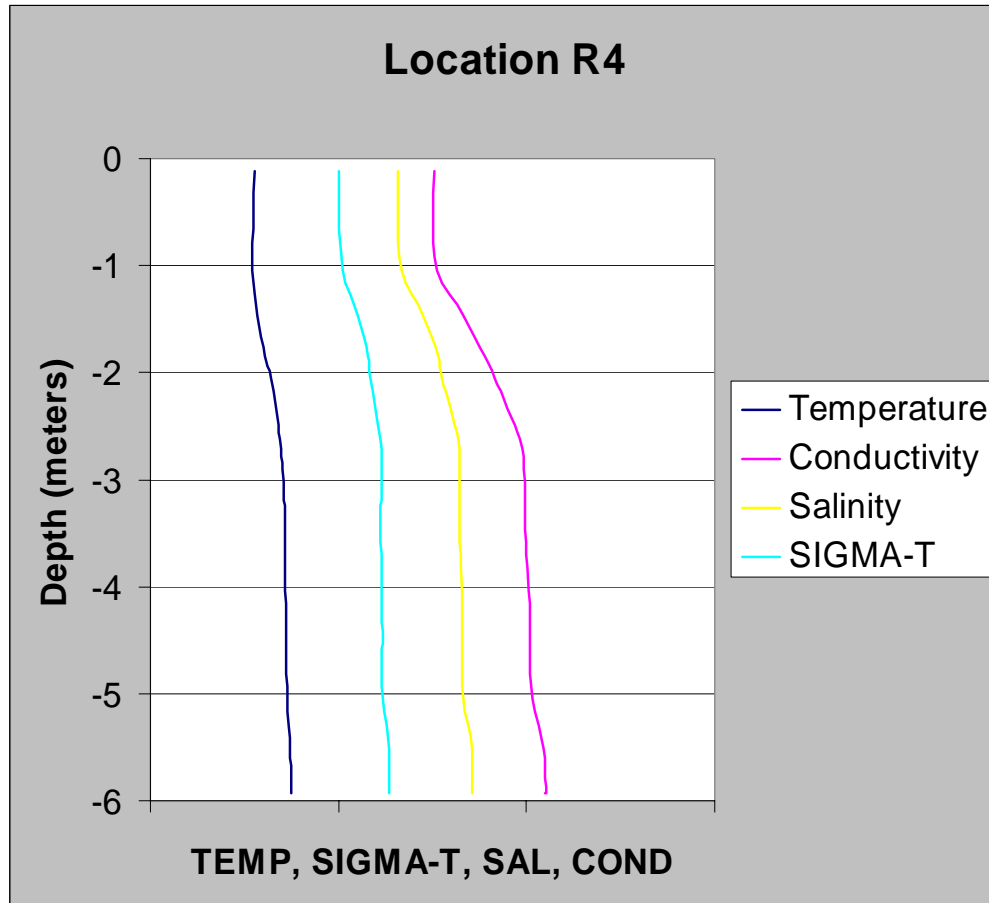

Figure 4. CTD measurement of St. Andrew's Bay at location R4. Results are indicative of Bay in general. SIGMA-T represents water Density. Negative values for depth represent distance below surface.

The extent of surface interaction is visible in the ray trace displayed in Figure 6. Note how many surface reflections occur over the short distance. The propagation model, based on the sound speed profile of Figure 5, indicates a 30 dB drop in signal strength (intensity) over just the first kilometer of propagation. The ray traces help with understanding the propagation difficulties in the upward-refracting shallow water environment.

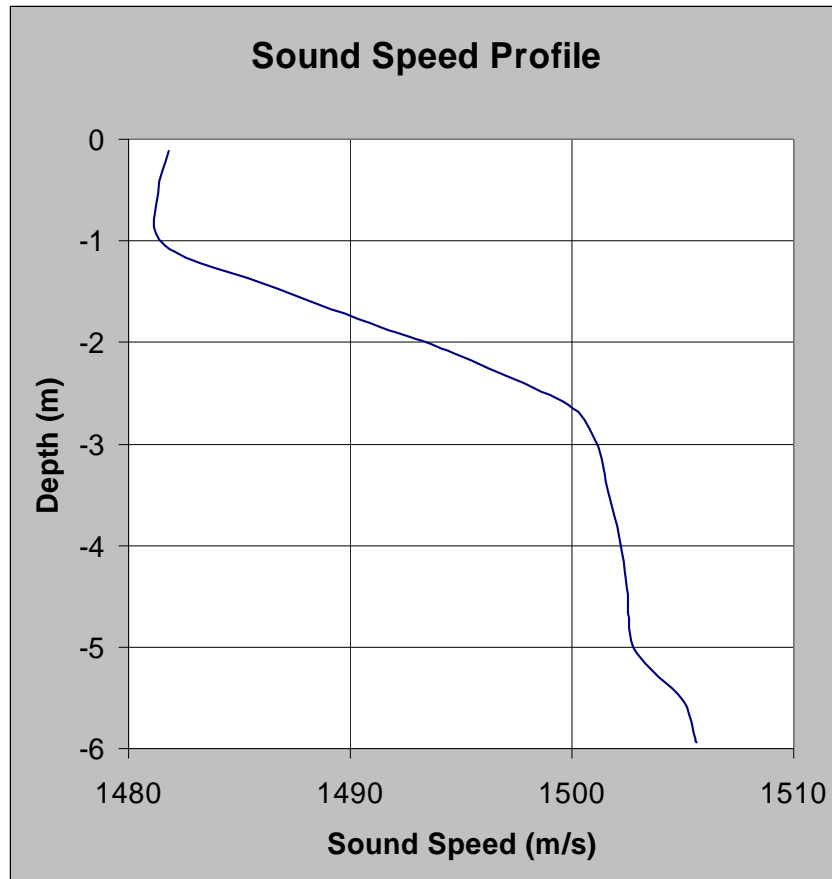

Figure 5. Sound speed profile at R4, indicative of Bay in general. Note gradient between one and three meters, refracting sound waves upward towards surface.

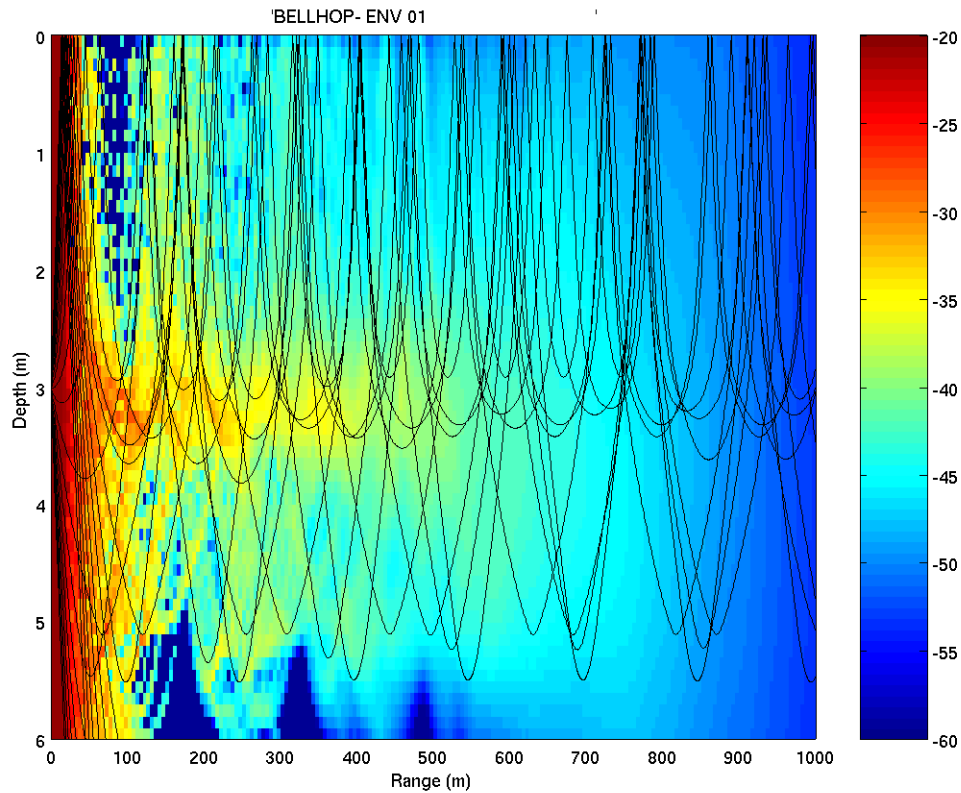

Figure 6. Ray traces modeled from sound speed profile (Figure 5). Source is located in middle of water column at a depth of 3 meters. Note number of surface reflections that occur in first kilometer of propagation, and their effect on signal intensity, in color (colorbar values in decibels). While this is only a model based on the sound speed profile, it represents the difficulty of operating in a shallow-water environment.

## D. ST. ANDREW’S BAY ACOUSTIC NOISE

### 1. Sources of Acoustic Noise

The location chosen to implement this Seaweb network was rich in noise. The Bay is not only a haven for various kinds of sea-life, but is also a busy waterway for man-made water traffic. Several important noise sources are discussed below.

#### a. Wind

Wind is a major contributor to ambient noise level. At the frequencies of interest (9-14 kHz), wind-driven noise is the dominant contributor. According to Wenz’s noise data, at 10 kHz a wind-speed difference of 5 knots can affect the ambient noise

level by greater than 5 dB [7]. Over the course of the experiment, the wind varied from calm to eight or ten knots.

***b. Boating***

As mentioned earlier, St. Andrew's Bay is part of the inter-coastal waterway. So in addition to the often numerous pleasure craft are commercial vessels traversing the channel. There were several instances of close passing barges along with dozens of high-speed boats. Depending on the distance from these vessels, there were times when the boating noise would completely drown out the modem signal.

***c. Construction***

An unexpected source of noise at St. Andrew's Bay was from construction of a new bridge spanning the Bay just north of the experiment site. Several floating platforms were in place under the old bridge which was being demolished, and machines were simply dropping pieces of the old bridge into these platforms. When this occurred the noise was significant.

***d. Biologics***

Noise sources were not limited to weather considerations or man-made devices. Snapping shrimp proved to be a significant noise source. Tiny animals, they can create impressively loud clicks with an enlarged claw. This is done by causing cavitations of a water jet. The clicks are broad-band, covering all of the frequencies concerned with in this report. Depending on the proximity to a network receiving node, a click had the capability to completely wash out the signal for that instant.

**2. Noise Variability**

The noise proved difficult to model, due to the many variations. The wind speed was not constant over the course of the experiment. Shipping traffic intensity varied along with the amount of small boats on the bay. The effect of a vessel on a signal also depended on its proximity to the transmitting nodes. The snapping shrimp clicks, construction transients, and other events that occurred on short time scales were unpredictable. Identifying noise sources and attempting to quantify them showed that the implementation of the Seaweb network in St. Andrew's Bay was truly representative of operation in a littoral environment.

THIS PAGE INTENTIONALLY LEFT BLANK

## IV. ST. ANDREW'S BAY MODEM PERFORMANCE AND DATA COLLECTION

### A. TEST PROCEDURE

#### 1. Test Geometries

The three channel geometries discussed above were all tested on the same day, 14 January 2004, at the times indicated in Table 1. For each location, approximately 10 dialogues were recorded. A dialogue is to be considered an attempt at transmitting a data packet. The data packet sent was the same for every dialogue, a compressed image file. The images used in the Seaweb experiment were obtained previously with the SDV periscope and with an underwater camera mounted on an AUV. The 77,878-byte images were compressed using a 50:1 wavelet compression algorithm to obtain 1532-byte files. As stated earlier, the data packet was divided into six subpackets of equal size (256 bytes).

Transmitting Node	Distance to G1 (meters)	Data Transmission Rate (bits/sec)	Date of Transmission		
			Day	Time	
				Start	Finish
R4	2330	800	14 JAN	1454	1522
R5	1300	800	14 JAN	1145	1210
R8	985	800	14 JAN	1413	1431

Table 1. Experiment details for each of the three locations used in the SRQ evaluation.

#### 2. Seaweb Database

As stated earlier, through FreeWave radio communications, knowledge of the signal's success was known immediately. With this feedback, power level settings were adjusted so as to intentionally drive the link margin to failure. The Seaweb server was used to set the power level and also to log diagnostics for of each transmission. This detailed log proved invaluable as a reference during data analysis.

### 3. Transmit Power Level Setting

The desired power level setting could be inputted into the server. There were eight power level settings, at source level increments of 3 dB. Table 2 shows each power level and its related acoustic source level, in decibels referenced to one micro Pascal at one meter from the source.

Power Level	Source Level (dB ref 1 $\mu$ Pa @ 1 meter)
8	185
7	182
6	179
5	176
4	173
3	170
2	167
1	164

Table 2. Seaweb Power Level relationship to acoustic Source Level.

### 4. Procedure

The objective of the experiment was to transmit imagery files with varying power level settings, lowering the power level to the point where transmissions were no longer successful, which is what is meant by driving the link margin to failure. For a given test geometry, the 1532-byte (6 subpackets) packet was transmitted at a given power level. If the packet was not received in full uncorrupted, the corrupted subpackets were resent through the SRQ mechanism. Retransmission attempts were limited to five for each dialogue. If the file was not received in full with five SRQ retries, the dialogue was abandoned. Figure 7 provides a visual layout of the SRQ evaluation. The mobile node V3, which was a U.S. Navy research vessel, acoustically transmits its packet to G1

acoustically. G1 then sends immediate confirmation back to V3 through FreeWave radio communications.

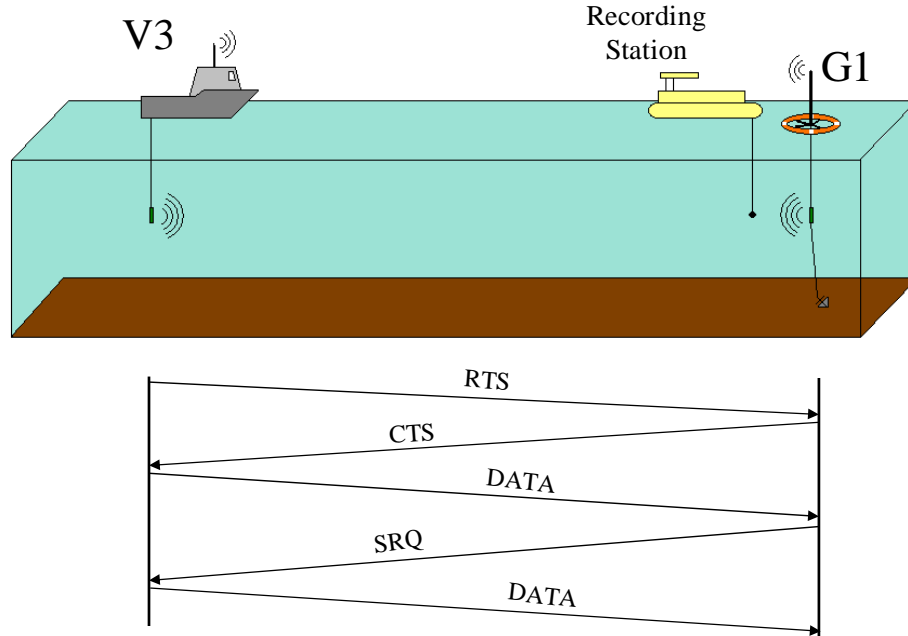

Figure 7. Experimental setup for SRQ Analysis. V3 transmits from its over-the-side dunking transducer and the G1 acoustic modem receives the signal. V3 and G1 remain in contact via FreeWave radio for immediate transmission confirmation. The dialogue underlay consists of one SRQ retry, with up to five possible.

## B. OBSERVATIONS

A total of 28 dialogues were recorded from the three test geometries. Within each dialogue, a record was kept of each transmission. Power level, subpackets sent, and subpackets corrupted were recorded for each transmission. The displays in Figure 8 organize the dialogues in order of decreasing power level for each of the three geometries.

For example, for the 985-meter range, at power-level 7 all six subpackets were successfully received, while at power-level 6 only four subpackets were successfully received on the first try. The two corrupted subpackets were successfully received on the first SRQ retry. At the 2330-meter range, the first dialogue at power-level 5 had three successful subpackets on the first try, but no success on the following three retries. The protocol is set for five retries, but degrading channel conditions occasionally caused even

the header reception to fail, thus reducing the number of retries in some of the experimental events.

Ordering transmissions based on power level is somewhat deceiving. As noted earlier, the ambient noise in the Bay was extremely variable, so on a time scale of seconds the transmission channel changed. This ordering does show a general trend of dialogues at lower power levels having less success than those at higher power levels. Note that at the longer ranges higher power levels were required for success due to the larger range-dependent transmission losses.

The important factor is that the data set covers transmissions from complete success on the first attempt to complete failure. This range of test cases allows for an evaluation of the SRQ protocol.



Figure 8. Transmission results for all three test geometries. A dialogue is represented as a group of bars, with power level noted below each. As explained in Figure 2, one bar represents a single transmission. The total height of the bar represents the total subpackets sent in that transmission; the height of the red portion of a bar represents those subpackets that were received corrupt. If the last bar (transmission) of a dialogue is fully green, the file was successfully sent.

THIS PAGE INTENTIONALLY LEFT BLANK

## V. DATA ANALYSIS

### A. RECORDING STATION

Observing the success of transmissions at the subpacket level provides the best way to evaluate the SRQ function. But this needs to be set against a measurable performance criterion in order to derive any quantifiable results. In the context of the link margin, that parameter was chosen to be the signal-to-noise ratio of the signal at the receiving node. As portrayed in Figure 7, the experiment included a floating recording station at the location of the receiving gateway node G1. This set-up serves as an experimental control and is described below.

#### 1. Transducer

The recording transducer was submerged over the side of the recording boat at approximately the same depth as the receiving transducer of the gateway node. The transducer remained within 15 meters of the gateway node. The transducer used for recording was an International Transducer Corp. ITC-1032. The transducer's sensitivity is shown in Figure 9. The frequency response of the ITC-1032 was essentially flat (within several dB) over the 9-14 kHz transmission bandwidth.

#### 2. Preamplifier

The signal recorded from the transducer was sent through a Stanford Research SR560 battery powered preamplifier. The gain setting was 200. A band-pass filter was established from 3-30 kHz, in order to drop any noise outside of the bandwidth of interest.

#### 3. Tape Recorder

The amplified signal was sent to a TEAC RD-120T Data Recorder. The signal was recorded on two-channel AMPEX-467 digital audio tape. Channel 1 was set to a 2 Volt peak recording level, with channel 2 set to 5 Volts. Recordings were taken continuously over the experiment times listed in Table 1.

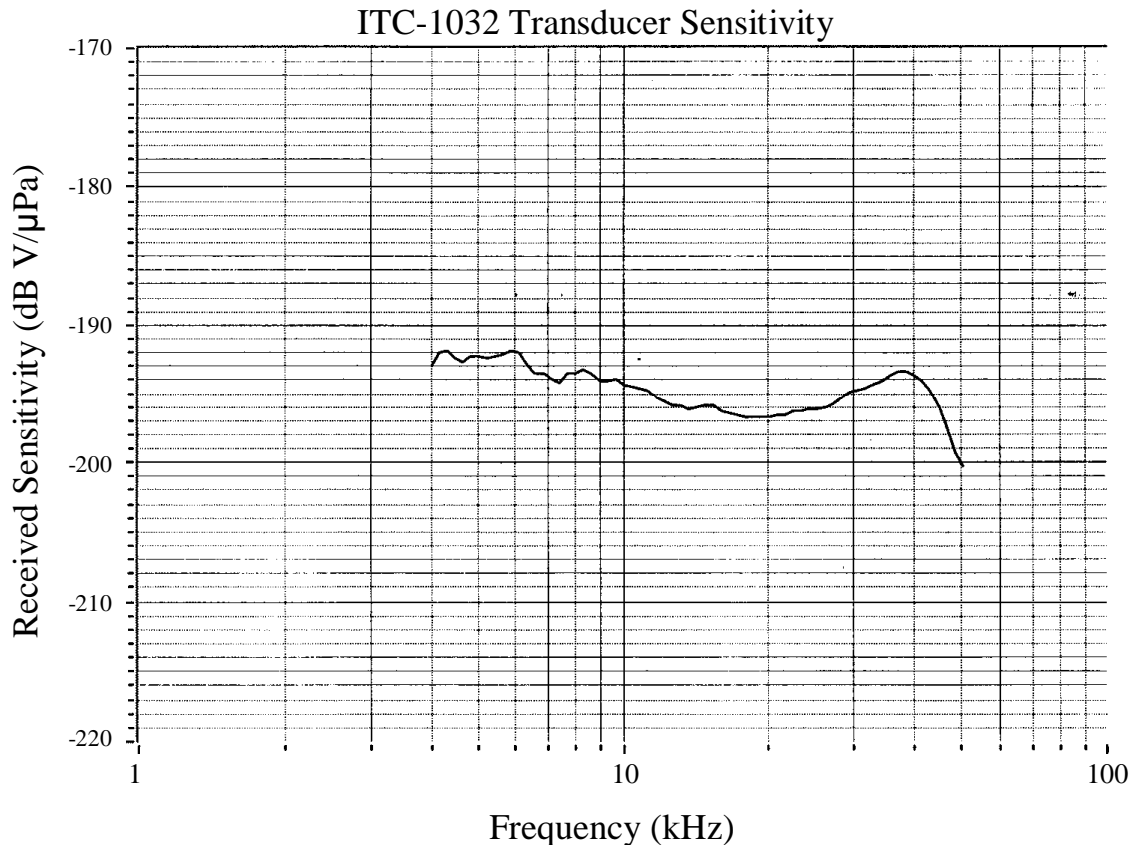

Figure 9. Sensitivity of ITC-1032 transducer. Over 9-14 kHz bandwidth the response curve is flat to within several dB.

**B. DATA EXTRACTION**

Extraction of the audio tape data was done with the Stanford Research SR785 Analyzer in the Fast-Fourier Transform (FFT) mode. Channel 1 of the tape was played into the analyzer and a series of FFTs were averaged over the course of a signal transmission. Averaging a number of FFTs smoothes out the signal, but at the same time it averages out the effect of a large snapping shrimp click or other transient. Thus the averaged FFTs are an approximation of individual signal receptions, but at the same time they are the best single representation of the received signal. For an entire data packet (all 6 subpackets), the analyzer compiled 1800 averages. The frequency range of the FFT was from 0 to 25.6 kHz, which encompasses the 9-14 kHz transmission bandwidth. A Hanning window was applied to each analysis time record, so the edges of the time window were brought to zero. Windowing prevents non-zero signal values at the edges

of the time window from contributing spurious spectral energies across the entire spectrum.

Because of the 3-30 kHz filter on the preamp, only an accurate representation of the received signal can be considered from approximately 5 kHz to 25 kHz. Figure 10 shows the averaged FFTs for transmissions from the three experimental ranges. The received signal is visible as the rise in the response over the 9-14 kHz range. Notice the range dependence of transmission loss, as the strongest signal was sent from the closest range. Also notice the variability in the noise levels for the three transmissions. The sharp signal drop-off near 25 kHz is due to the previously mentioned filters.

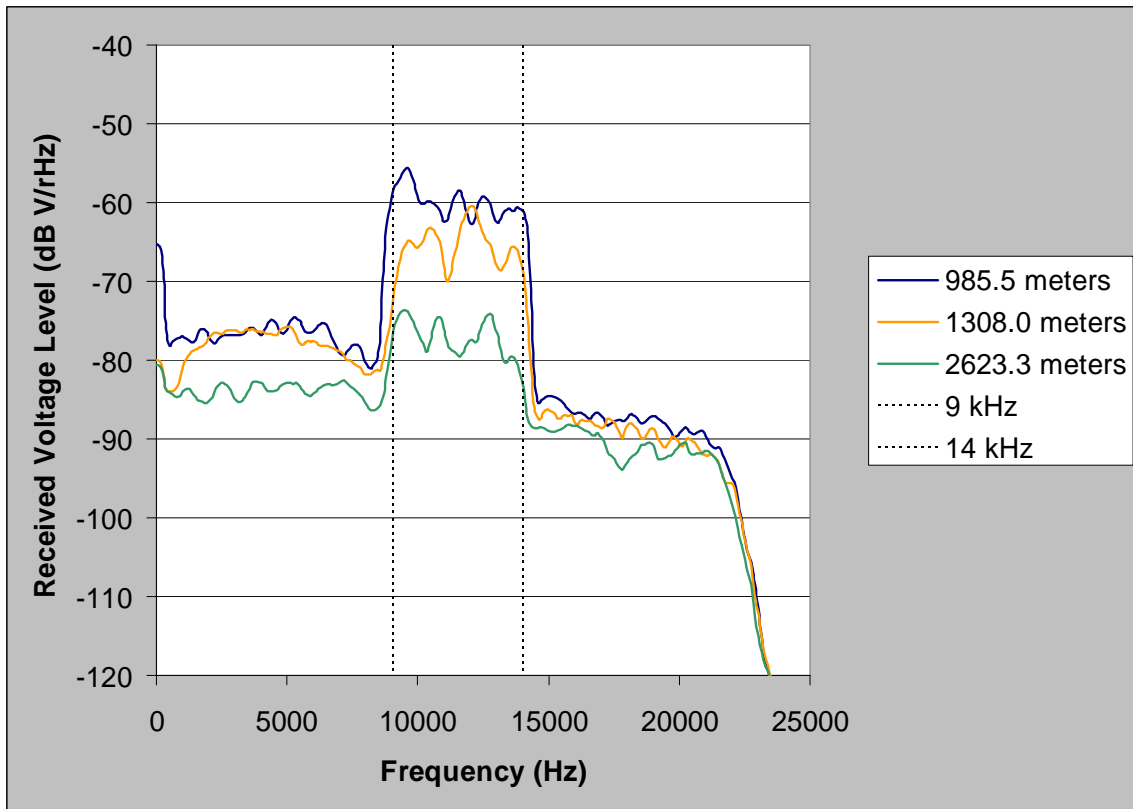

Figure 10. Stanford Analyzer display for transmissions at three different ranges. Note variability in noise levels and the range dependence of transmission loss. Vertical lines at 9 and 14 kHz encompass modem signal transmission bandwidth.

SNR is simply the ratio of the signal at the receiver to the ambient noise at the receiver. An important consideration is the fact that the signal recorded by the ITC-1032 transducer was in fact the signal at that frequency plus the noise at that frequency. Due to

the fact that the noise and signal are uncorrelated, combining the two requires the Pythagorean sum shown in Equation (1) [8,9]. If the signal is at least twice the noise, the signal plus noise differs from the signal by 12%. If the signal is three times the noise, the difference is only 5%, and only 3% if it is four times the noise.

$$S + N = \sqrt{S^2 + N^2} = S \sqrt{1 + \left(\frac{N}{S}\right)^2} \quad (1)$$

Since a signal-to-noise ratio of 2 to 1 in decibels is 6 dB, and the majority of SNRs recorded in this experiment were 10 dB and higher, approximating S+N to just S assumes a maximum difference of 10%, more often less than 5%. This makes S+N a good approximation for the actual received signal.

With the above approximation in mind, the SNR was extracted from the display by simply taking the height in dB of the signal portion in the 9-14 kHz band, and subtracting from it the height of the surrounding noise. Since the SNR value may be slightly different across the 9-14 kHz band for a given transmission, the smallest SNR was always taken. The advantage of the SNR is that it can be compared from one signal to another without having to take into account the absolute noise levels and transmission losses for each specific signal. Thus the receptions from each of the three test geometries can be accurately compared using SNR as a consistent metric.

## VI. SELECTIVE ARQ RESULTS

As stated earlier, the purpose for the SNR extraction is to find a method to quantitatively evaluate the success of the SRQ protocol. SNR is an appropriate metric because it allows for results to be independent of absolute signal and noise levels, and transmission ranges.

### A. SNR BASED PERFORMANCE

For each of the 80 transmissions recorded for the 28 dialogues at the three ranges, SNR was measured using the FFT analysis method described in the previous chapter. Figure 11 displays all 80 of these transmissions in order of decreasing SNR. Note that the graph is not linear with respect to SNR, but simply arranges each transmission in order of SNR.

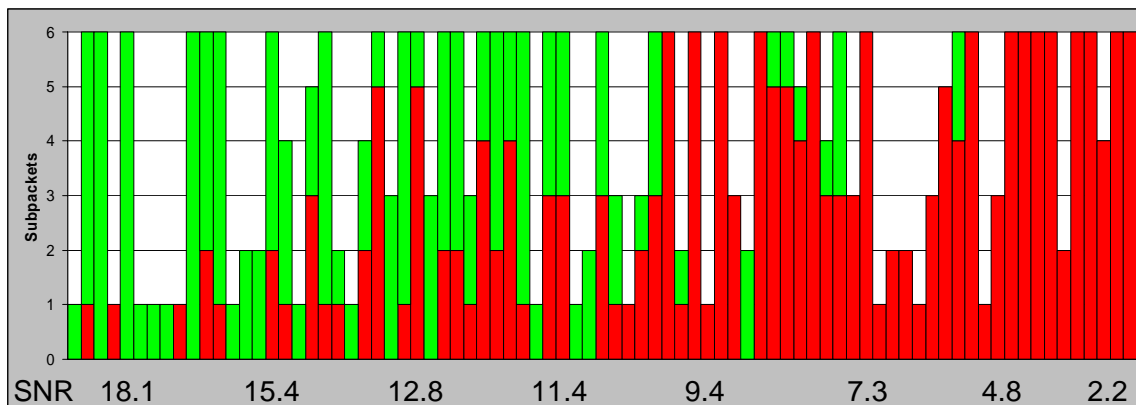

Figure 11. For all data at all three ranges, each independent transmission is displayed in order of decreasing SNR. Note that the plot is not linear with respect to SNR.

Ordering the transmissions in this fashion reveals the expected trend of diminishing communications effectiveness as a function of SNR reduction. Below 5 dB of SNR, not one subpacket was successfully received. There are several outliers in the data set, mainly involving just one or two subpackets. Notice the two unsuccessful receptions of a single subpacket around 18 dB, while below 9 dB there was a successful reception of a two-subpacket signal. This is due to the FFT averaging of the signal. In the case of the unsuccessful subpackets with high SNRs, over the course of the reception there were one or two extremely loud snapping shrimp clicks amongst an otherwise very

quiet background. These one or two clicks were enough to corrupt a subpacket but their effects were hidden by the averaging.

To plot the SRQ performance linearly, reception success was used as the parameter to plot against SNR. Reception success was calculated on a subpacket level. For example, if a full message containing 6 subpackets was sent, and 3 were corrupted, the success for that reception was 50%. Figure 12 shows all 80 receptions on a success vs. Received SNR plot with SNR is in decibels. Each transmission was appropriately weighted according to the number of subpackets sent. The red line in Figure 12 represents a linear regression of the displayed data with the weighting taken into account. What this meant was that a 6-subpacket signal had 6 times the effect on the regression as that of a 1-subpacket signal.

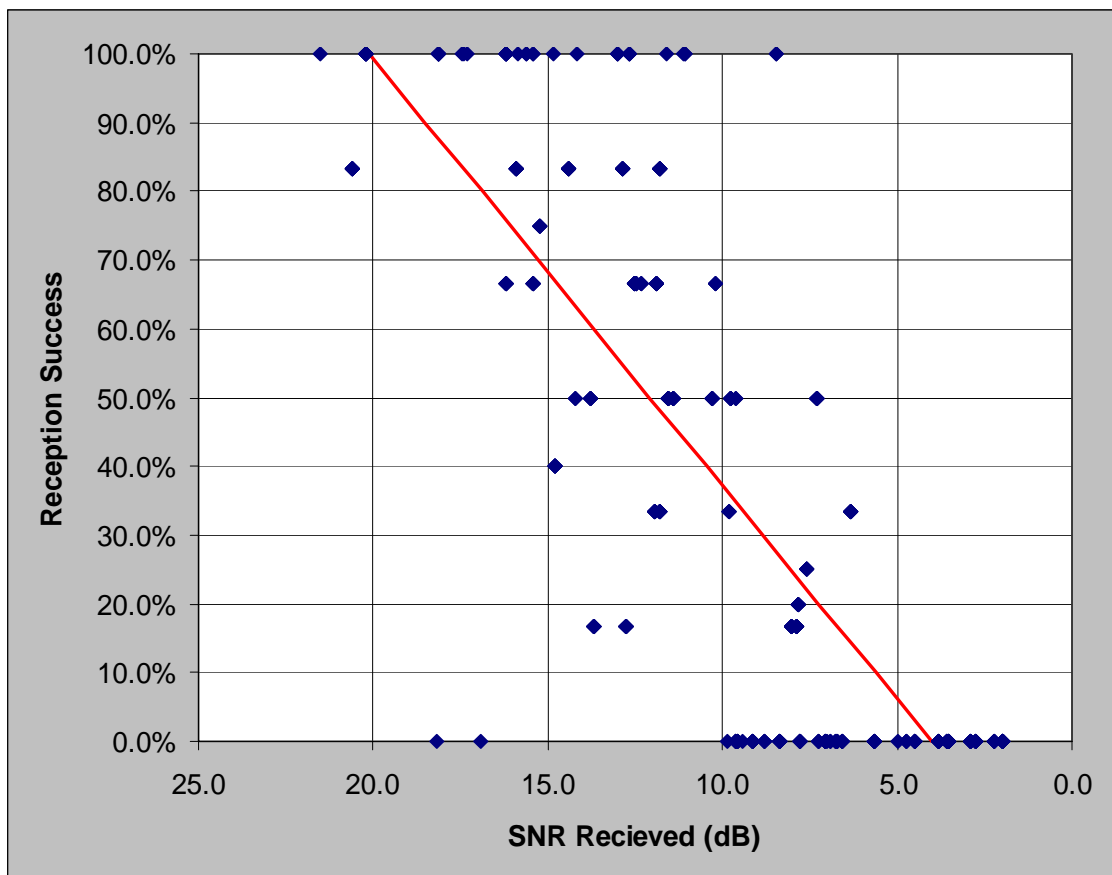

Figure 12. Reception success rate plotted against received SNR for each transmission. Data points are weighted according to number of subpackets sent. The red line is a linear regression of all 80 data points.

The red line shows that at and below 4 dB of SNR the expectation is that there should be no success at all. A signal above 20 dB SNR should expect complete reception success. An important note to this is that in a July 2003 experiment in St. Andrew's Bay the same imagery files were sent through a Seaweb network with almost no success. There was no SRQ implemented at that time. For successful reception, a SNR of more than 20 dB had to be achieved for the entire signal through every link of the network.

As can be seen in the graph almost every reception that achieved a SNR of greater than 10 dB had some success, often times a significant amount. In this experiment, there were cases of imagery file telemetry success where none of the receptions in the dialogue achieved even 15 dB of SNR. This was due to the fact that complete success had to be achieved on only a subpacket basis and not an entire packet basis.

## **B. SRQ GAIN**

Figure 11 shows that with the incorporation of the SRQ protocol into the link layer, imagery file telemetry success can be achieved with lower received SNR than if it is not incorporated. What this means is that large files can be telemetered in more difficult propagation environments. But to what extent? In order for link-layer efficiency to remain high, there must be a minimum number of SRQ retries. If there are too many retries then the SRQ protocol becomes inefficient due to the amount of time it will take retransmitting. An ideal number of retries would be zero, but this would be the same as having no SRQ. Allowing for an average of 2-3 retries will keep the dialogue time for a packet down while still allowing for retransmission of the data. An arbitrarily chosen success rate of 66% will on average get total packet reception success in 2-3 SRQ retries. According to Figure 11, 66% reception success corresponds to a SNR of 15 dB from the red regression curve. Since 20 dB is necessary for complete reception success on the first try, requiring only 66% success per transmission allows for a 5 dB decrease in the received SNR. This 5 dB decrease is what can be considered the "SRQ gain." This allows for the received SNR to be just over half as much as what was previously required without the SRQ mechanism.

THIS PAGE INTENTIONALLY LEFT BLANK

## VII. INCORPORATING SRQ GAIN INTO LINK-BUDGET MODEL

In June 2002, LT J.T. Hansen, USN completed a thesis titled “Link Budget Analysis for Undersea Acoustic Signaling.” In his thesis he developed a MATLAB based model for analyzing frequency-dependent acoustic signaling in the underwater environment. He applied a link-budget analysis commonly used in wireless communications to the basic sonar equation [10]. He was able to model propagation characteristics for many environments and scenarios. In this chapter his model will be calibrated to the St. Andrew’s Bay environment and then used to show that the incorporation of the “SRQ gain” into the sonar equation increases the effective transmission range for imagery and other large files.

### A. LINK BUDGET CALIBRATION

The basis for the link-budget model is the sonar equation, shown in equation (2) without directivity considerations at the transmitter or receiver.

$$SNR = PSL - TL - AN \quad (2)$$

Values are in dB. SNR is the same signal-to-noise ratio described in the previous chapters. TL is transmission loss, and AN is ambient noise. PSL is pressure spectrum level.

#### 1. Pressure Spectrum Level

Pressure spectrum level is dependent on both SL (source level) and bandwidth. It is similar to SL but takes into account the signal energy distributed over the frequency band. Equation (3) shows the relationship of SL to PSL with W representing the frequency bandwidth.

$$PSL = SL - 10\log_{10}(W) \quad (3)$$

For the SRQ evaluation, the bandwidth was 5 kHz, and the source levels are represented by the power levels in Table 2. We assume a flat transmitter response across the operating band.

#### 2. Ambient Noise

Ambient noise proved to be difficult to model for the St. Andrew’s Bay environment. As described in Chapter III, the noise environment is variable and is

constituted by many sources. Hansen's generalized ambient noise assumptions in his link-budget model will not suffice in this study. The noise for St. Andrew's Bay was determined using the experimental data. For each of the 80 recorded transmissions, the noise level was taken from 5 kHz to 25 kHz (excluding the 9-14 kHz bandwidth). A linear regression was performed on these data and then used to interpolate the noise in the 9-14 kHz transmission bandwidth. This gives a good representation for the noise in the Bay. The measured noise has to be converted from received voltage level in dB Volts per square root Hertz, which is a relative value, to absolute AN in dB referenced to 1 micro Pascal per square root Hertz. The following equation is used to make that conversion.

$$AN = e_n - A_v - M_v \quad (4)$$

The term  $e_n$  is the received noise voltage level.  $A_v$  is the preamplifier gain, which was 200, or 40 dB.  $M_v$  is the transducer sensitivity, which is shown in Figure 9.

### 3. Transmission Loss

Transmission loss is a function of range from the transmitter to receiver. There are three types of transmission loss considered in this analysis. The first is transmission loss due to geometric spreading. For ranges out to the depth of the water column, the pressure wave spreads spherically, and beyond this range it spreads cylindrically, constrained by the surface and bottom. The following are the equations for transmission loss due to spreading [8].

$$TL_{sphere} = 20 \log_{10}(r) \quad (5)$$

$$TL_{cylind} = 10 \log_{10}(r) \quad (6)$$

The second type of transmission loss is that due to attenuation. The following two equations model frequency dependent absorption in seawater.

$$\alpha = \frac{0.11f^2}{1+f^2} + \frac{44f^2}{4100+f^2} + 3.0 \times 10^{-4} f^2 + 3.3 \times 10^{-3} \quad (7)$$

$$TL_{attenuation} = \alpha r \times 10^{-3} \quad (8)$$

In Equation (7) alpha is the coefficient of attenuation and is in dB/km, while in Equation (8) r is range in meters.

Both of the above two types of transmission loss are considered in Hansen's link-budget model. In this study there was another type of transmission loss, that due to reflection off the surface and/or bottom in our shallow water environment. As Figure 6 shows there are many interactions with the surface. This  $TL_{refl}$  can be found using Equation (2) and the SNR data. The SNR was determined for each of the 80 transmissions. PSL can be determined from each of those transmissions using the power level. With the ambient noise solution found above along with the transmission loss models for attenuation and spreading, the only missing factor is the transmission loss due to interaction with the surface and bottom, or  $TL_{refl}$ . Therefore an empirical solution can be found by calibrating the transmissions. Due to the range dependence, the transmission loss due to surface and bottom interaction was fit to a  $\log(r)$  dependence,

$$TL_{refl} = 4.4 \log_{10}(r) \quad (9)$$

Range is in meters. Again it is important to note that this equation was an empirical determination found from the data set.

## **B. MODELING ST. ANDREW'S BAY**

All the components of the link-budget model have been calibrated for the St. Andrew's Bay environment during the experiment. The model can now be used as a tool for showing the value of incorporating SRQ into the link-layer protocol. Figure 13 shows SNR as a function of frequency and range. The coloring shows the area where reception is successful (green), where reception begins to break down (yellow), and where reception is unsuccessful (red). The color scheme in Figure 13 was calculated without the SRQ gain incorporated, so it shows the area coverage for transmissions without the SRQ protocol in place. As stated before, without SRQ a received SNR of 20 dB is necessary for successful reception. Within the 9-14 kHz band, successful telemetry of data messages extends out to approximately 1300 meters.

Figure 14 does incorporate the SRQ Gain into the SNR calculation. This pushes the successful reception region out to the 15 dB contour line. The successful telemetry of data messages within the operational bandwidth now extends out beyond 2000 meters.

This is more than a 50% increase in effective range. This is an extremely cost-effective gain considering the transducer does not have to be re-engineered or the power level increased.

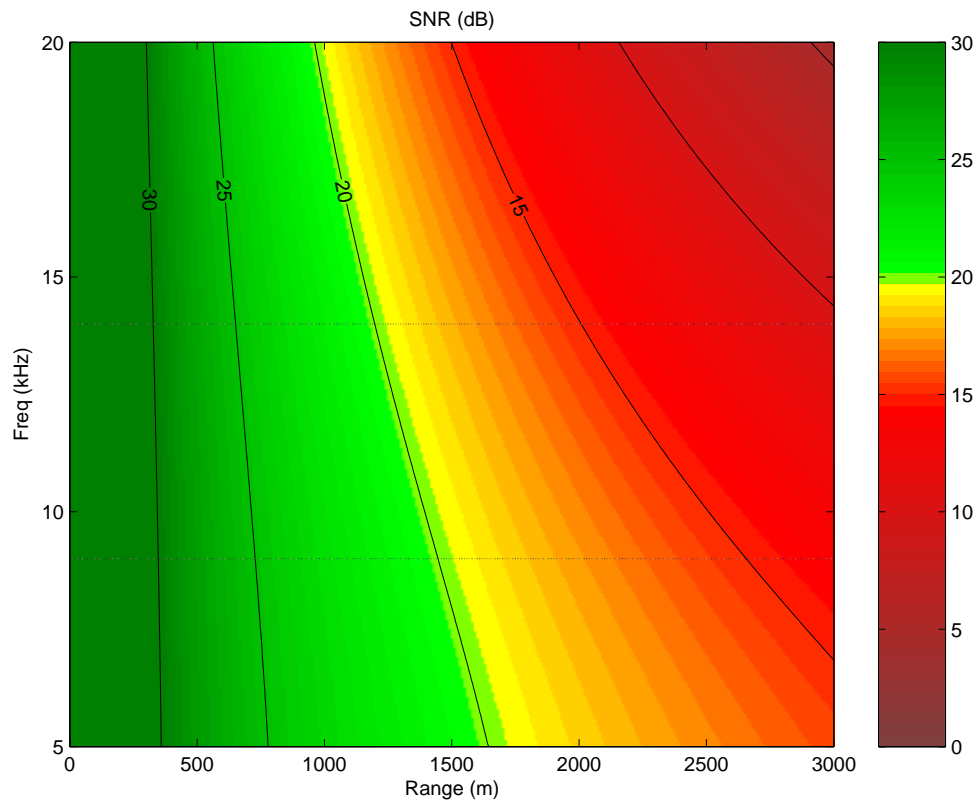

Figure 13. Link-budget model output for St. Andrew’s Bay environment, without SRQ Gain. Power level setting is 8. Horizontal dashed lines indicate frequency bandwidth of interest. Green indicates successful reception areas, while yellow indicates the point at which the link begins to break down, and finally red indicates areas of no reception success. For this Figure, with no SRQ in place, the operating range is only around 1300 meters.

This model shows that communications range can be increased with the implementation of SRQ, but there is another consideration. Implementing SRQ can allow for lower transmitted power levels for a given effective range. The advantages to this are conservation of battery power and transmission security. In general, the data show distinct advantages in the implementation of the SRQ protocol for telemetry of large data packets.

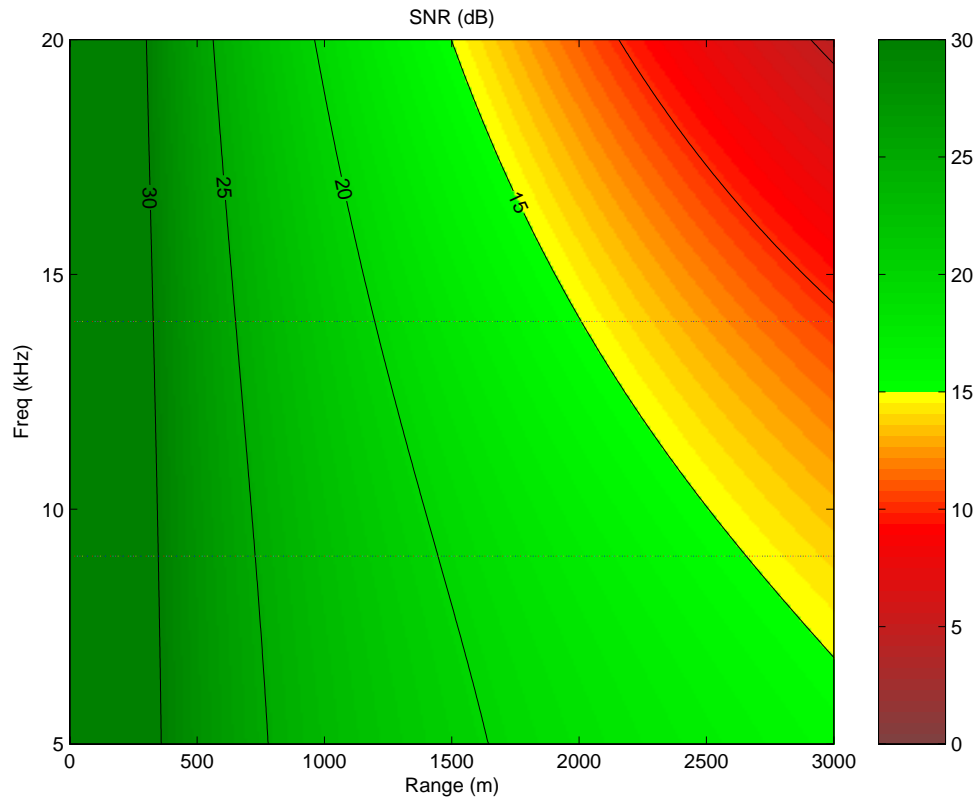

Figure 14. Link-budget model output with SRQ gain incorporated. All other factors are same as Figure 12. Note new effective range out to more than 2000 meters.

THIS PAGE INTENTIONALLY LEFT BLANK

## VIII. FUTURE IMPROVEMENTS

The SRQ protocol has been implemented only recently for use in the Seaweb Underwater Wireless Network. There is room for further improvements in error detection and correction. Several possibilities related to SRQ are discussed below.

### A. ABORT/CONTINUE LOGIC

Currently, the maximum number of SRQ retry attempts is a static parameter. There are cases where a more fluid implementation could prove more effective. This would involve incorporating an abort/continue logic into the protocol. For example, if the number of SRQ retries was set to 5, and the propagation conditions were horrible, the modem may try to send the entire data message 6 times in a row with no success at all. In this case, with the logic in place, after only 1 or 2 completely unsuccessful attempts the power level would be increased and transmission would continue, saving time.

In another case, for example, with the number of SRQ retries set to 2, a 6-subpacket message is being successfully received 1 or 2 subpackets at a time. The message will not be successfully telemetered because the number of SRQ retries will be exceeded before all the subpackets are received. A logic sequence could be implemented that sees this trend and extends the number of retries for that dialogue in order to get those last few subpackets. Again this method would save time in that the entire signal would not have to be resent in a new dialogue.

### B. TIMEOUT LOGIC

Another type of logic that could be implemented in the SRQ protocol would be one that times-out for a short period. This could be effective at saving power in cases where a temporary noise event is disrupting the channel. If transmissions have been received without much error over a certain time and suddenly the conditions degrade, the modem will then timeout and wait a specified time instead of attempting to send a signal and waste power.

### C. CROSS-LAYER TIME-DIVERSITY PROCESSING

If the same subpacket fails in consecutive transmissions, an algorithm could combine the two receptions to achieve SNR gain, possibly enough for successful reception. This can be done with cross-layer time-diversity processing, which is a method

of forward error correction. The important factor is that there is no required overhead in the transmitted signal.

## IX. CONCLUSIONS

The Selective Automatic Repeat Request function is one of many protocols implemented as part of Seaweb underwater communications. Although it is a small feature, it contributes significantly to the effectiveness of the network. Using SRQ does not require much overhead in the transmitted signal, just 2 bytes for every 256 bytes. This is an important factor due to the limited throughput inherent in underwater telemetry. The protocol divides data packets into subpackets to allow for telemetry of large imagery files, in fulfillment of a Naval Special Warfare need for near-real-time reporting.

St. Andrew's Bay, typical of a shallow water littoral environment, proved to be a challenging location to test the SRQ protocol. The shallow-water upward refracting channel was impaired by the interactions with the surface. From heavy vessel traffic to construction to snapping shrimp, the Bay was rich in noise. On one previous occasion, prior to implementation of the SRQ protocol, virtually no success was achieved with imagery file telemetry.

At the January 2004 Seaweb NSW Experiment, a method for recording data transmissions was established, and the SRQ mechanism was evaluated in order to determine its effectiveness at mitigating the losses caused by the unreliable physical propagation medium. Three test geometries of different ranges were established and imagery files were sent across these links. Based on the success of these telemetry attempts, along with the SNR determined from recording the receptions, a quantitative method for evaluation of the SRQ protocol was determined. The data show that an effective "SRQ Gain" of 5 dB was achieved.

This SRQ Gain was then incorporated into an underwater link-budget model calibrated to the St. Andrew's Bay environment. With the SRQ Gain, the range for effective transmissions increased more than 50%. If the effective range remained static, then the transmitted power level could be significantly dropped as a benefit of SRQ.

There is still much work to be done in evaluating the SRQ protocol. Additional larger tests must be set up with collection of thousands of data points in order to more

significantly measure the effectiveness of SRQ in other environmental conditions. Optimizing the established parameters would prove worthwhile, such as subpacket size and number of transmission retries.

As for Naval Special Warfare applications, SRQ is an important refinement to Seaweb for networked image telemetry.

## LIST OF REFERENCES

- [1] J. A. Rice, "Enabling Undersea Forcenet with Seaweb Acoustic Networks," *Biennial Review 2003*, SSC San Diego Technical Document, 2003.
- [2] E. Varvarigos, T. Varvarigou, "Computer Communications Protocols," *Encyclopedia of Telecommunications*, Wiley, 2002, 538-545.
- [3] *Embedded Systems Programming*, November 1999, 48.
- [4] *Embedded Systems Programming*, December 1999, 54.
- [5] M. Coryer, "Description of Selective Repeat Request (SRQ) As Implemented in the Benthos Acoustic Modem," Benthos, Inc. Technical Document, April, 2004.
- [6] J. A. Rice, "Seaweb NSW 2004 Experiment Plan and CONOPS," Draft 2, December, 2003.
- [7] Robert J. Urick, *Principles of Underwater Sound*, 3<sup>rd</sup> Edition, McGraw-Hill, 1983, 213.
- [8] Robert E. Simpson, *Introductory Electronics for Scientists and Engineers*, 2<sup>nd</sup> Edition, Prentice Hall, 1987, 335.
- [9] John R. Taylor, *An Introduction to Error Analysis: The Study of Uncertainties in Physical Measurements*, 2<sup>nd</sup> Edition, University Science Books, 1997, 60.
- [10] J. T. Hansen, *Link Budget Analysis for Undersea Acoustic Signaling*, MS Thesis, Naval Postgraduate School, Monterey, CA, June, 2002.

THIS PAGE INTENTIONALLY LEFT BLANK

## INITIAL DISTRIBUTION LIST

1. Defense Technical Information Center  
Ft. Belvoir, Virginia
2. Dudley Knox Library  
Naval Postgraduate School  
Monterey, California
3. Joseph A. Rice  
Naval Postgraduate School  
Monterey, California
4. Thomas J. Hofler  
Naval Postgraduate School  
Monterey, California
5. Hannah Kessler, LT, USN  
Naval Postgraduate School  
Monterey, California
6. Dr. Tom Swean  
ONR 3210E  
Arlington, VA
7. Mike Doctor  
Coastal Systems Station  
Panama City, Florida
8. Danny Daniels  
Coastal Systems Station  
Panama City, Florida
9. Melissa Smoot, CDR, USN  
PMS NSW  
Navy Yard, Washington, D.C.
10. Chris Fletcher  
SPAWAR Systems Center  
San Diego, California
11. Bob Creber  
SPAWAR Systems Center  
San Diego, California

12. Paul Baxley  
SPAWAR Systems Center  
San Diego, California
13. Bill Marn  
SPAWAR Systems Center  
San Diego, California
14. Jon M. Kalscheuer, ENS, USN  
Naval Postgraduate School  
Monterey, California